

2 . CASSETTE TYPE

- AU * 12FBAB, AU * 12UBAB**
- AU * 14FBAB, AU * 14UBAB**
- AU * 18FBAB, AU * 18UBAB**

2-1. FEATURE

MODELS :

AU*12FBAB / AO*12FSAJ
AU*12UBAB / AO*12USAJL
AU*14FBAB / AO*14FSDJ
AU*14UBAB / AO*14USDJL
AU*18FBAB / AO*18FNCKL
AU*18UBAB / AO*18UNCNL
AO*18UNCNL



CASSETTE TYPE
AU12-18

CASSETTE TYPE
AU12-18

FEATURES

● Compact size

Compact grille fits European ceiling panel (650 x 650 mm).

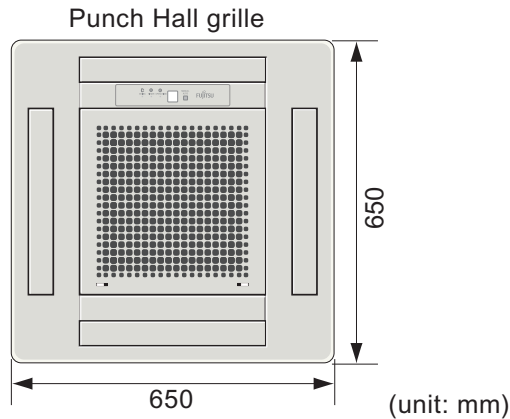

● Slim intake grille

Slim type intake grille can fit the ceiling after installation.

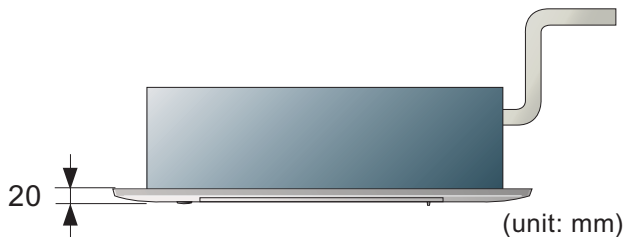

● Detachable, washable filter and intake grille.

Intake grille and air filter can be removed easily and cleaned.

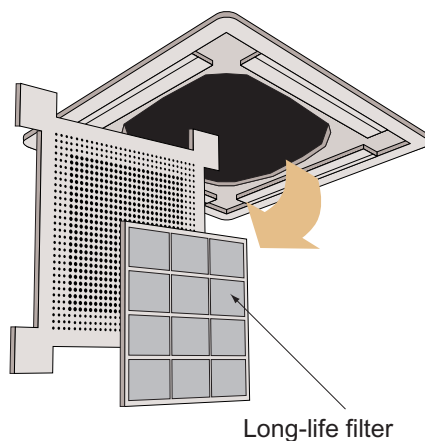

● **Duct connection hole opening**

Fresh air can be introduced through this opening.

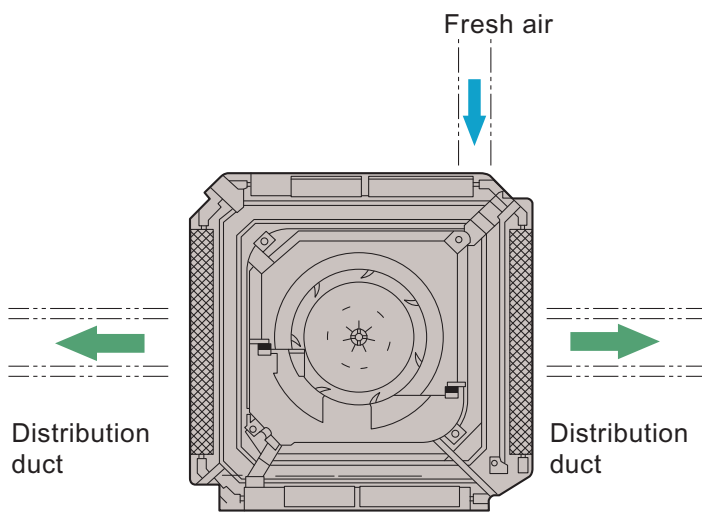

● **Conditioned air can be distributed by means of a distribution duct.**

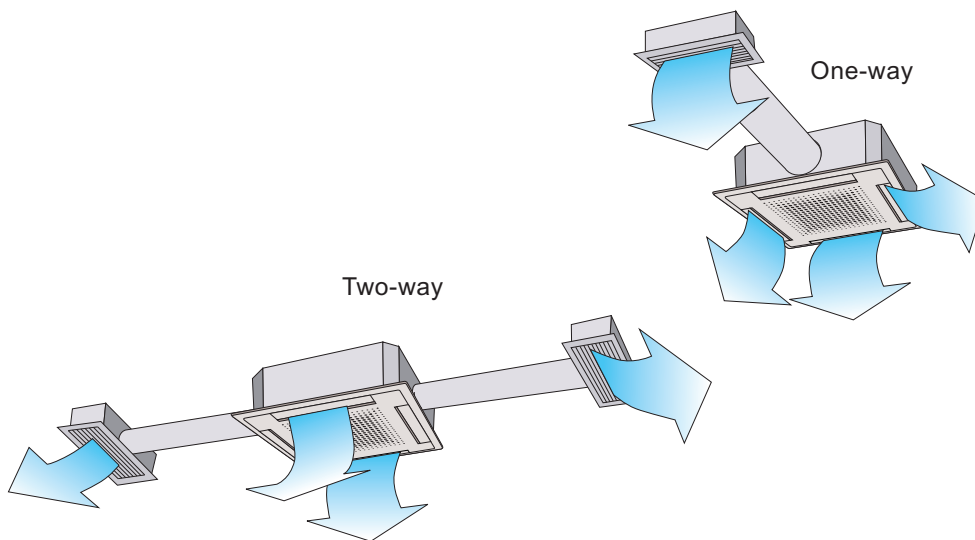

2-2. REMOTE CONTROLLER

2-2-1. WIRELESS REMOTE CONTROLLER

■ FEATURES



- * Four kinds of timer setup (ON / OFF / PROGRAM / SLEEP) are possible.
- * Four kinds of timers. Easy operation.
- * Easy to change transmission code (4 patterns) by button operation.

● Built-in timers

Select from four different timer programs (On/Off/Program/Sleep).

● Program timer

The program timer operates the ON and OFF timer once within a 24 hour period.

● Sleep timer

The sleep timer function automatically corrects the temperature thermostat setting according to the time setting to prevent excessive cooling and heating while sleeping.

Cooling operation/dry operation

When the sleep timer is set, the set temperature automatically rises 1°C every hour. The set temperature can rise up to a maximum of 2°C.

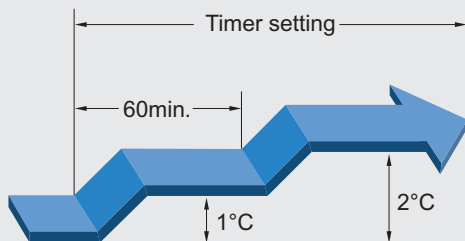

Heating operation

When the sleep timer is set, the set temperature automatically drops 1°C every 30 minutes. The set temperature can drop to a maximum of 4°C.

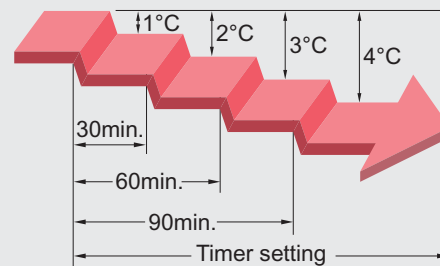

● Simultaneously operation

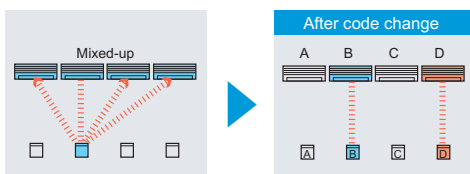

- Code selector switch eliminates unit being wrongly switched. (Up to 4 codes can be set.)



- Wide and precise transmitting range.

1. Press the MASTER CONTROL button for more than five seconds to start the code change.
2. Press the (+) or (-) button to select the desired code.
→ A → B → C → D
3. Press the MASTER CONTROL button again to end the code change.

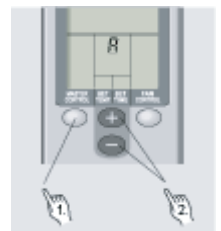

FUNCTIONS

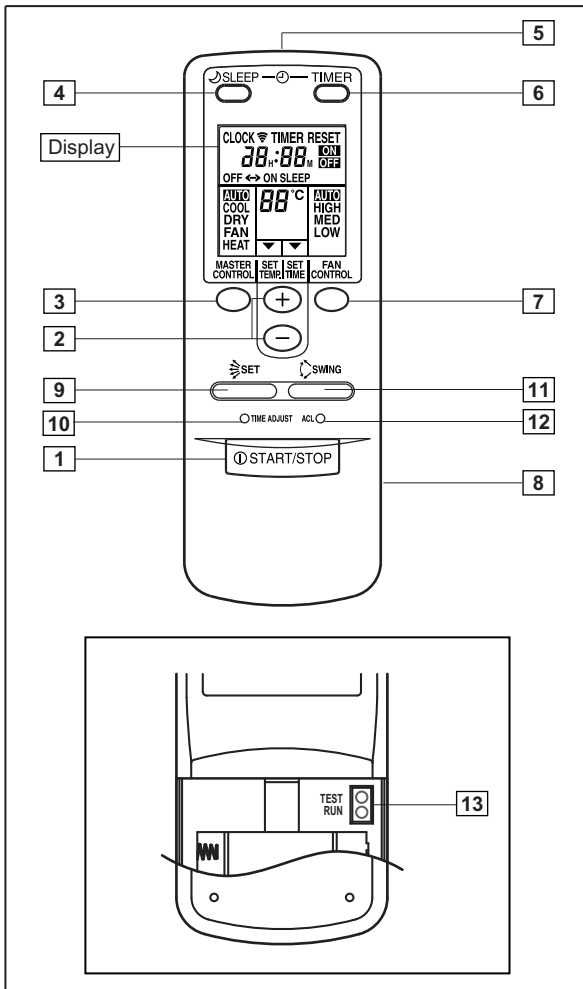

- 1 START/STOP button
Pressed to start and stop operation
- 2 Set temp./Set time/
Set remote controller custom code buttons
Sets the indoor temp./ Sets the current time and on-off time.
/Sets R.C. custom code.
- 3 Master control / Code change buttons
Selects the operating mode (AUTO, HEAT, FAN, COOL, DRY).
/Start / end R.C. custom code change. (Max 4 types)
- 4 Sleep timer button
Pressed to select sleep timer.
- 5 Signal transmitter
- 6 Timer button
Pressed to select the timer mode. (OFF TIMER, ON TIMER,
PROGRAM TIMER, TIMER RESET)
- 7 Fan control button
Selects the fan speed (AUTO, LOW, MED, HIGH).
- 8 Battery compartment lid
- 9 Air flow direction set button
- 10 Time adjust button
Sets the current time.
- 11 Air flow direction swing button
- 12 ACL button
Used when replacing batteries or change the code.
- 13 Test run button
Used when testing the air conditioner after installation.

Display panel

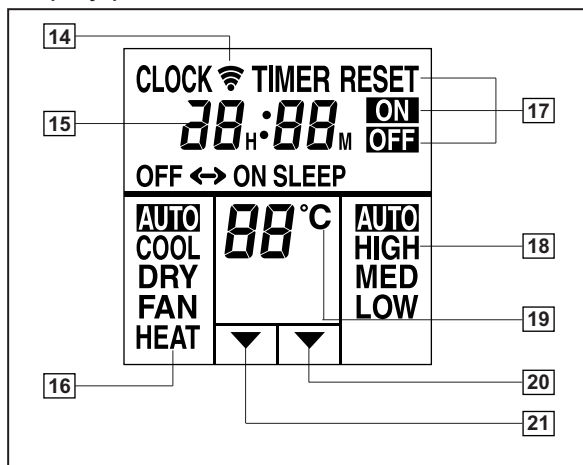

- 14 Transmit indicator
- 15 Clock display
- 16 Master control display
- 17 Timer mode display
- 18 Fan speed display
- 19 Set temperature display
- 20 Timer set indicator
- 21 Temperature set indicator

SPECIFICATION

SIZE (H x W x D mm)	160 x 56 x 20
WEIGHT (g)	120
ACCESSORY	Holder

2-3. SPECIFICATIONS

CASSETTE TYPE
AU12-18

CASSETTE TYPE
AU12-18

TYPE			CASSETTE MODELS							
			COOLING TYPE			HEAT PUMP TYPE				
MODEL NAME	INDOOR		AU * 12FBAB	AU * 14FBAB	AU * 18FBAB	AU * 12UBAB	AU * 14UBAB	AU * 18UBAB		
	OUTDOOR		AO * 12FSAJ	AO * 14FSDJ	AO * 18FNCKL	AO * 12USAJL	AO * 14USDJL	AO * 18UNCKL		
POWER SOURCE			230V ~ 50Hz							
AVAILABLE VOLTAGE RANGE			198 - 264V ~ 50Hz							
EUROPEAN ENERGY LABEL			COOLING	C	C	D	C	D		
CAPACITY	COOLING	RATED	kW	3.60	4.10	5.00	3.55	3.95	4.85	
			BTU/h	12300	14000	17100	12100	13500	16600	
	HEATING	RATED	kW	-	-	-	4.00	4.60	5.40	
			BTU/h	-	-	-	13700	15700	18400	
INPUT POWER	COOLING	RATED	kW	1.24	1.39	1.90	1.24	1.40	1.85	
	HEATING	RATED	kW	-	-	-	1.21	1.42	2.00	
CURRENT	COOLING	RATED	A	5.5	6.3	8.5	5.5	6.3	8.2	
	HEATING	RATED	A	-	-	-	5.4	6.3	9.2	
STARTING CURRENT			A	30.0	31.0	39.0	30.0	31.0	39.0	
EER			COOLING	2.90	2.95	2.63	2.86	2.82	2.62	
COP			HEATING	-	-	-	3.31	3.24	2.7	
MOISTURE REMOVAL			l/h (pints/h)	1.3(2.7)	1.5(3.2)	2.1(4.4)	1.3(2.7)	1.5(3.2)	2.1(4.4)	
AIR CIRCULATION COOL/HEAT	INDOOR	High	m ³ /h	550/-		620/-	550/550		620/620	
		Med		500/-		520/-	500/500		520/520	
		Low		440/-		450/-	440/440		450/450	
		Quiet		-		-	-		-	
	OUTDOOR	High	1600/-		3400/-	1600/1600		3200/3200		
		Low	-		-	-		-		
FAN SPEED COOL/HEAT	INDOOR	High	r.p.m	750/-		800/-	730/730		800/800	
		Med		670/-		700/-	670/670		700/700	
		Low		590/-		600/-	590/590		600/600	
		Quiet		-		-	-		-	
	OUTDOOR	High	740/-		780/-	740/740		780/780		
		Low	-		400/-	440/440		400/400		
FAN TYPE x Q'ty			INDOOR	Turbo x 1						
			OUTDOOR	Propeller x 1						
FAN MOTOR OUTPUT			INDOOR	10		14	10		14	
			OUTDOOR	22		65	22		65	
NOISE LEVEL (SOUND PRESSURE)	INDOOR	High	dB(A)	42 / -		44 / -	42 / 43		44 / 45	
		Med		39 / -		41 / -	39 / 40		41 / 41	
		Low		36 / -		37 / -	36 / 37		37 / 37	
COOL/HEAT	OUTDOOR		49 / -		52 / -	49 / 50		52 / 53		
COMPRESSOR			TYPE	ROTARY						
			OUTPUT	1075	1150	1500	1075	1150	1500	
STARTING METHOD			Permanent Starting Condenser							
HEAT EXCHANGER TYPE	INDOOR	Coil	Copper tube							
		Fin	Aluminium							
		Rows x Stages	2 x 10							
		Fin Pitch	1.4							
			Coil Dimensions	210 x 1000 x 26.6						
	OUTDOOR	Coil	Copper tube							
		Fin	Aluminium							
		Rows x Stages	2 x 24		1 x 30		2 x 24		2 x 30	
Fin Pitch		1.45		1.3		1.45				
		Coil Dimensions	504 x 658 x 36.38		630 x 905 x 18.19		504 x 685 x 36.38		630 x 901 x 36.38	
CASING COLOR			INDOOR	White (5Y9/0.5NN)						
			OUTDOOR	Beige(10YR7.5/1.0NN)						
DIMENSIONS H x W x D	INDOOR	NET	mm	235 x 580 x 580						
				530 x 750 x 250		650 x 830 x 320		530 x 750 x 250		650 x 830 x 320
	GRILLE	35 x 650 x 650								
	OUTDOOR	GROSS		280 x 710 x 750						
				609 x 882 x 339		743 x 984 x 413		609 x 882 x 339		743 x 984 x 413
		GRILLE	70 x 720 x 720							
WEIGHT	INDOOR	NET / GROSS	kg(lbs)	18/23 (40/51)						
	OUTDOOR			34/36 (75/79)	35/37 (77/82)	52/56 (115/123)	34/36 (75/79)	35/37 (77/82)	52/56 (115/123)	
	GRILLE	2.2/4.3 (4.9/9.5)								
PIPE	CONNECTION METHOD			FLARE						
	SIZE	LIQUID	mm	φ 6.35(1/4 inc.)						
		GAS		φ 9.52(3/8 inc.)	φ 12.7(1/2 inc.)		φ 9.52(3/8 inc.)		φ 12.7(1/2 inc.)	
	MAX LENGTH			20(chargeless:7.5)						
MAX HEIGHT			8							
REFRIGERANT			TYPE	R410A						
			CHARGE	800	900	800	850	1000	1250	
REFRIGERANT OIL			TYPE	POE						
OPERATION(OUTDOOR)	COOLING	°C	21 to 43		0 to 43		0 to 43			
	HEATING		-						-7 to 24	
REMOTE CONTROLLER TYPE			Wireless			Wireless				
DRAIN PIPE	MATERIAL			PP						
	SIZE			mm						
			Outer diameter 37.0 / Inner diameter 32.0							

Note: Specifications are based on the following conditions.
 Cooling: Indoor temperature of 27 °CDB / 19 °CWB, and outdoor temperature of 35 °CDB/24 °CWB.
 Heating: Indoor temperature of 20 °CDB / 15 °CWB, and outdoor temperature of 7 °CDB/6 °CWB.
 Pipe length : 7.5 m, Height difference : 0 m.(Outdoor unit - Indoor unit)

2-4. DIMENSIONS

2-4-1. OUTDOOR UNIT

■ MODELS : AO*12F, AO*12U, AO*14F, AO*14U

(Unit : mm)

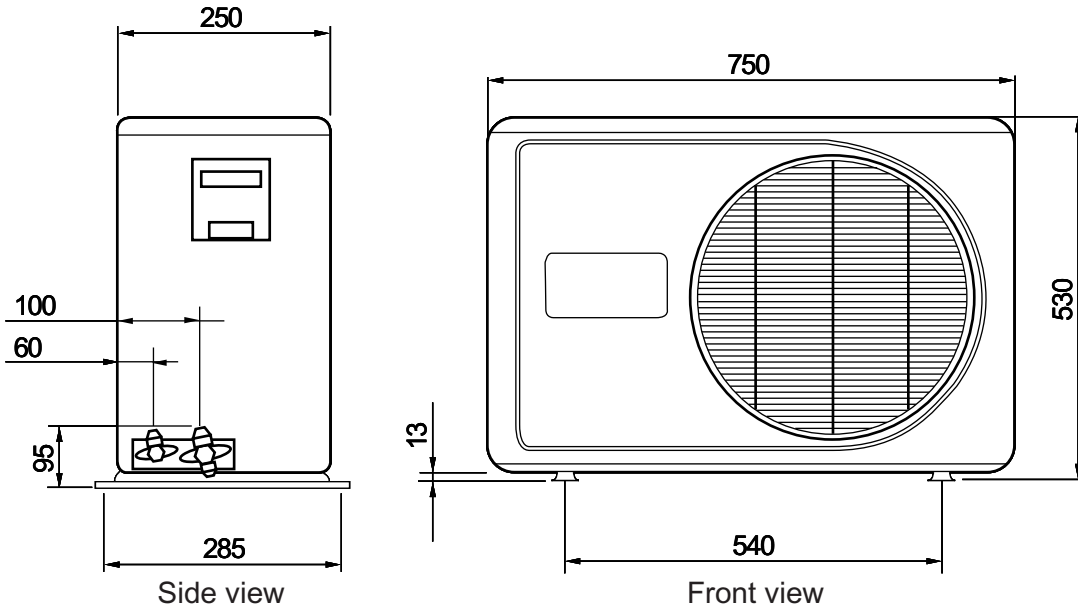

■ MOUNTING POSITION

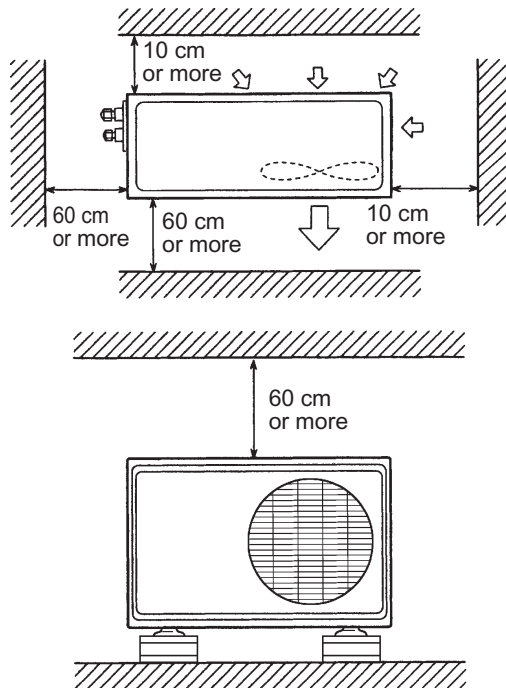

■ MODELS : AO*18F, AO*18U

(Unit : mm)

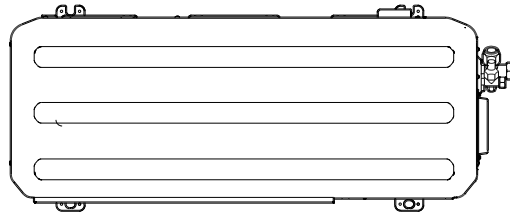

Top view

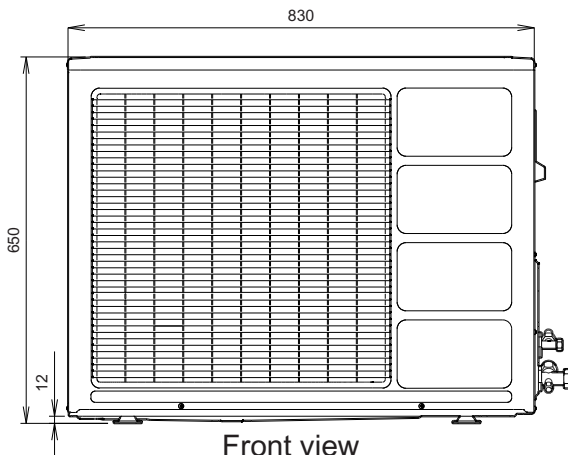

Front view

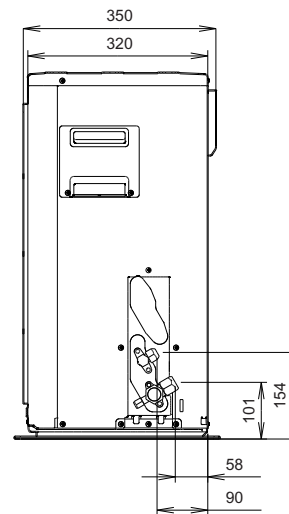

Side view

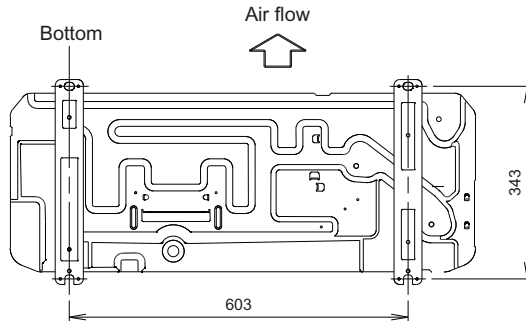

Bottom view

■ MOUNTING POSITION

When there are obstacles at the back or front sides.

When there are obstacles at the back, side(s), and top.

When there are obstacles at the back, side with the installation of more than one unit.

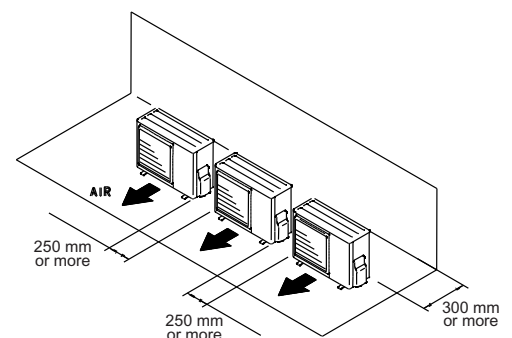
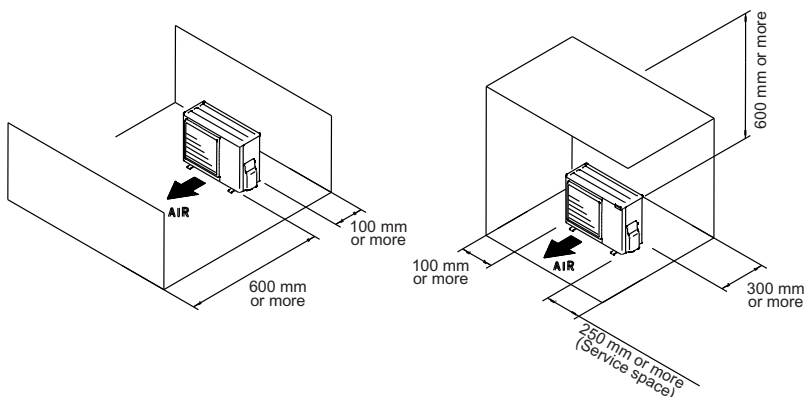

2-4-2. INDOOR UNIT

■ MODELS : AU*12F, AU*12U, AU*14F, AU*14U, AU*18F, AU*18U

(Unit : mm)

CASSETTE TYPE
AU12-18

CASSETTE TYPE
AU12-18

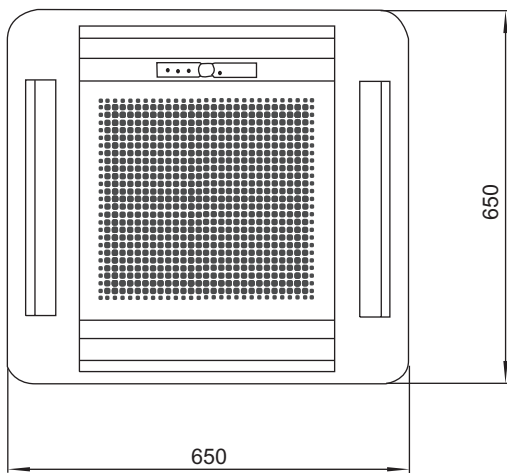
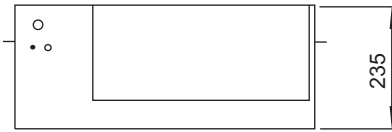

Bottom view (Panel)

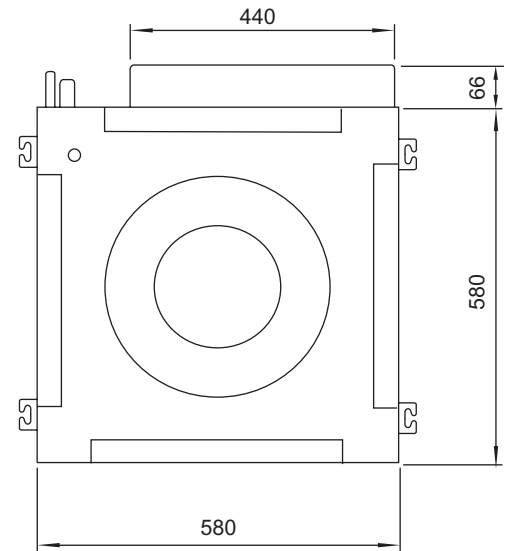

Bottom view

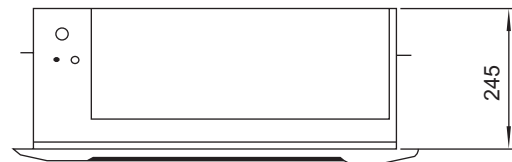

Side view

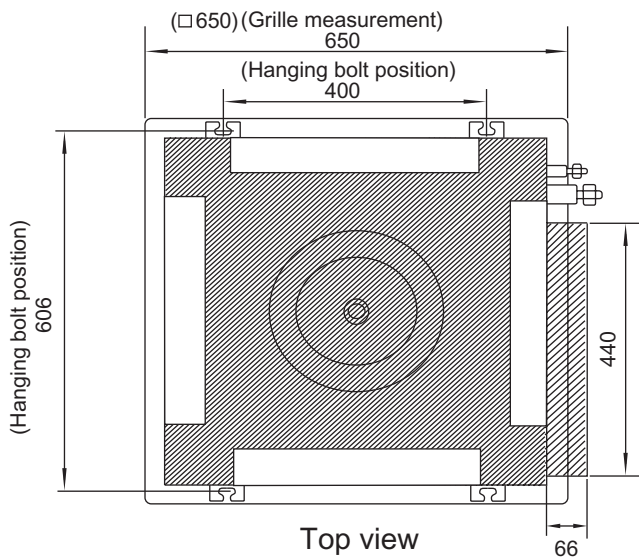

Top view

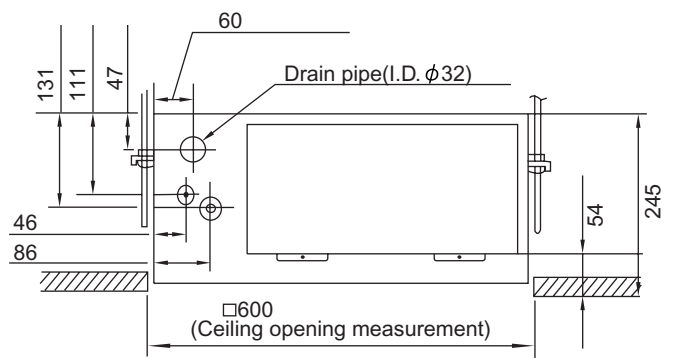

■ MOUNTING POSITION

CASSETTE TYPE
AU12-18

CASSETTE TYPE
AU12-18

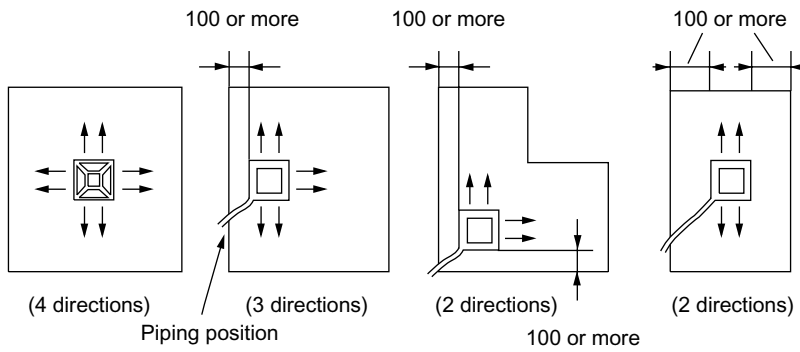
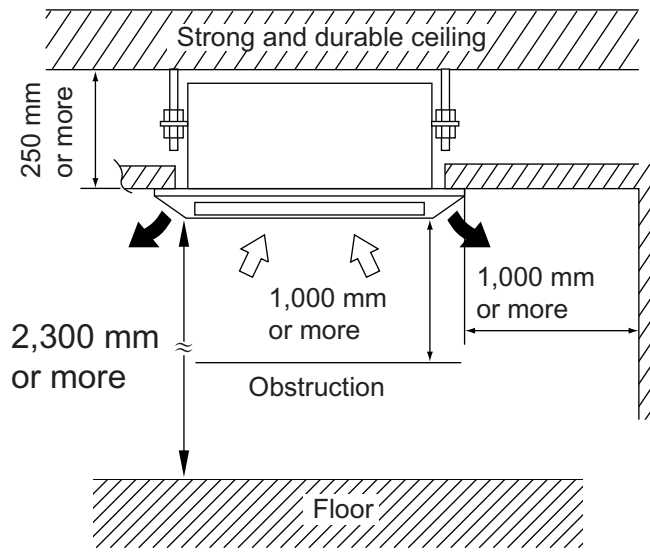

2-5. REFRIGERANT CIRCUIT

■ MODELS : AU*12F / AO*12F

CASSETTE TYPE
AU12-18

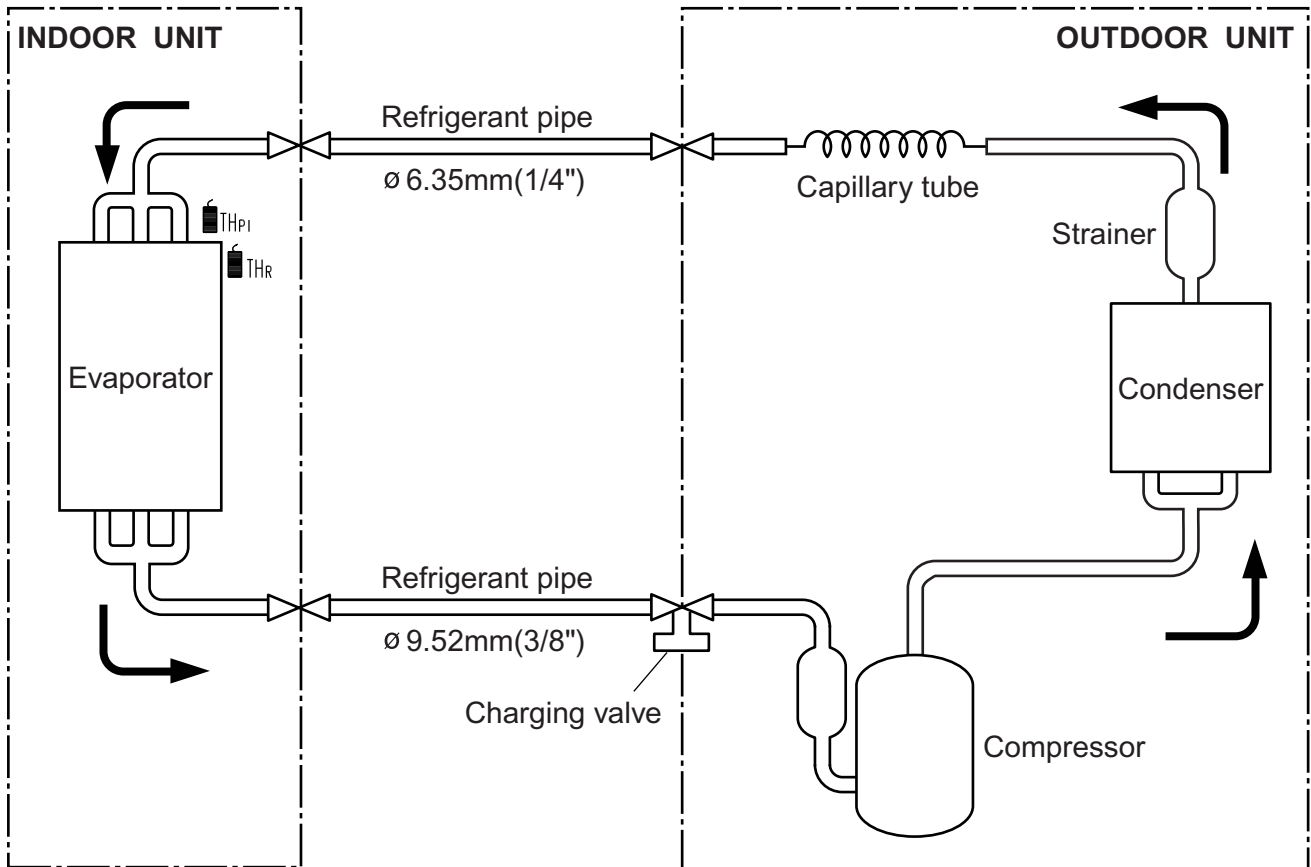

CASSETTE TYPE
AU12-18

■ MODELS : AU*12U / AO*12U

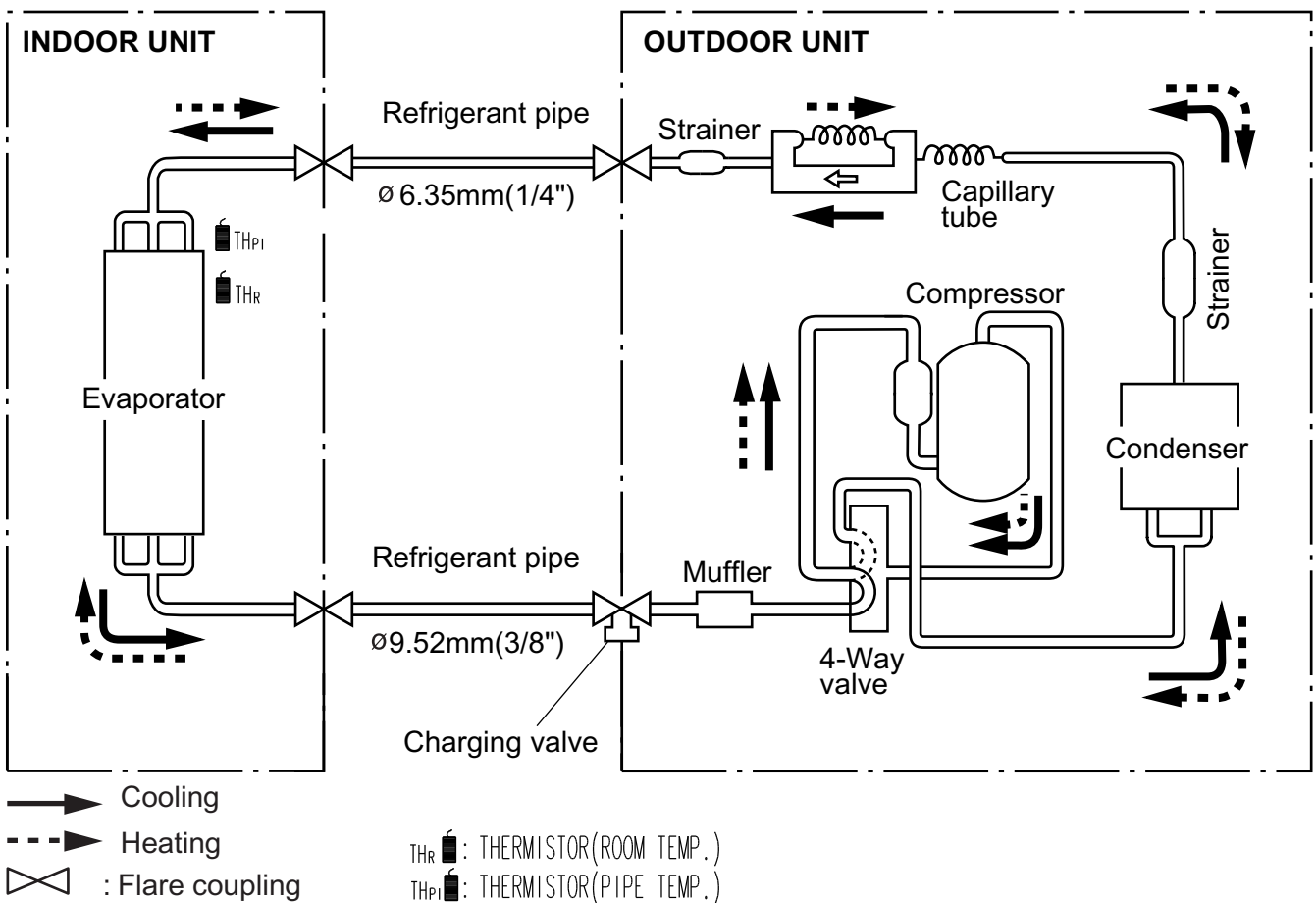

■ MODELS : AU*14F / AO*14F

CASSETTE TYPE
AU12-18

CASSETTE TYPE
AU12-18

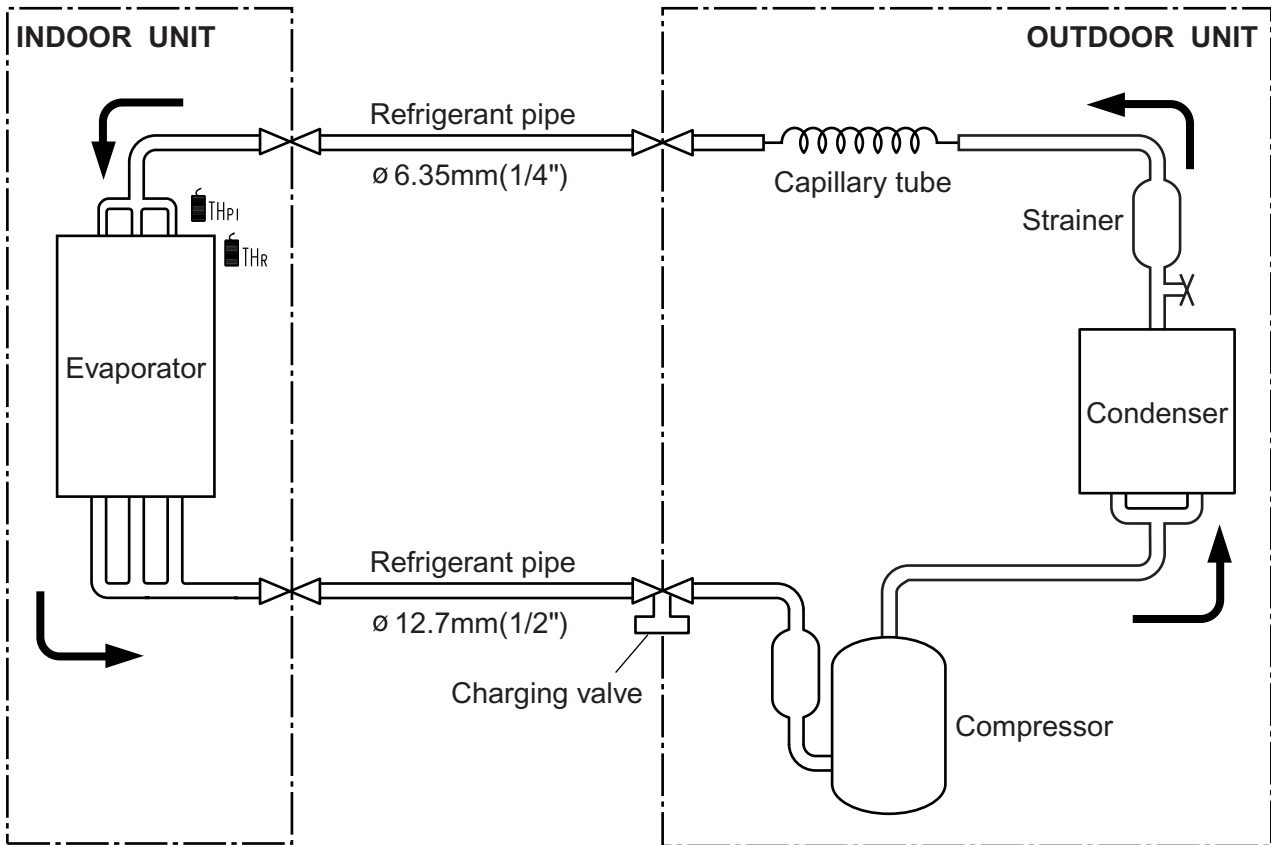

■ MODELS : AU*14U / AO*14U

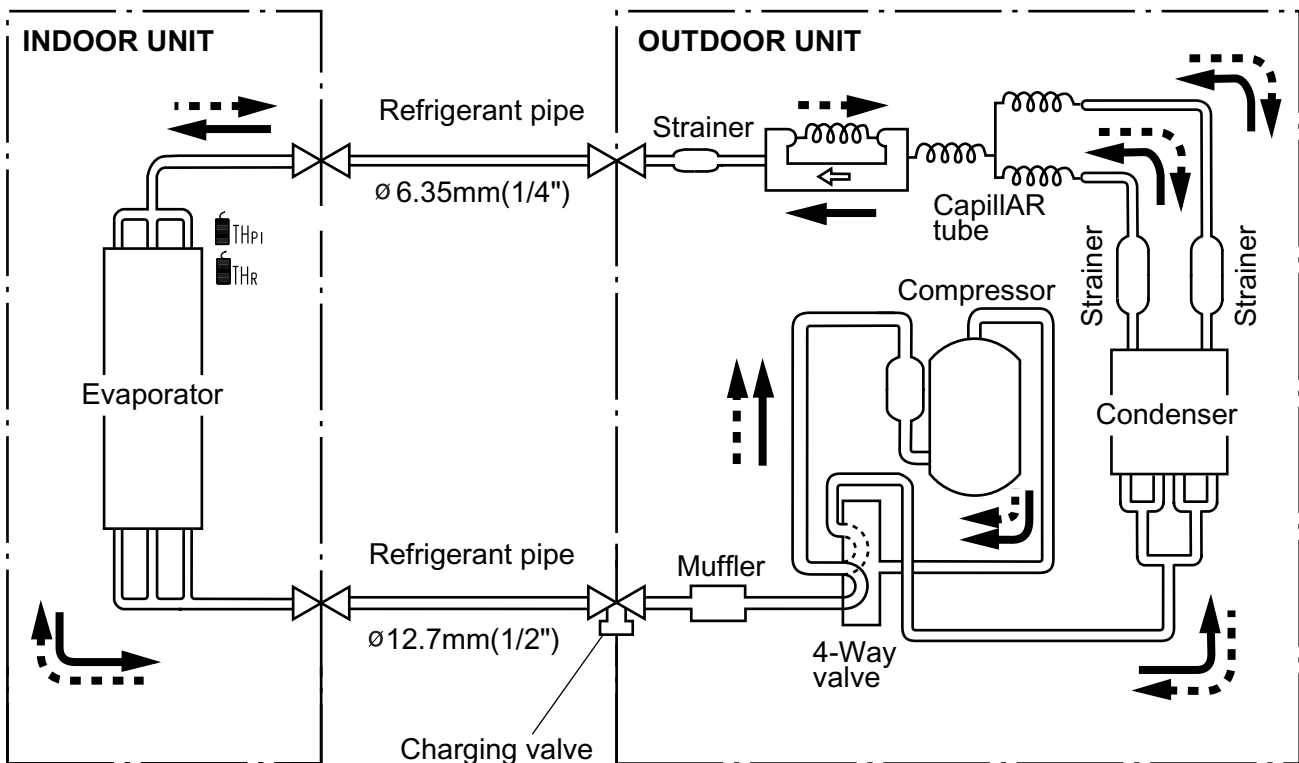

- Cooling
- Heating
- : Flare coupling

: THERMISTOR (ROOM TEMP.)
 : THERMISTOR (PIPE TEMP.)

■ MODELS : AU*18F / AO*18F

CASSETTE TYPE
AU12-18

CASSETTE TYPE
AU12-18

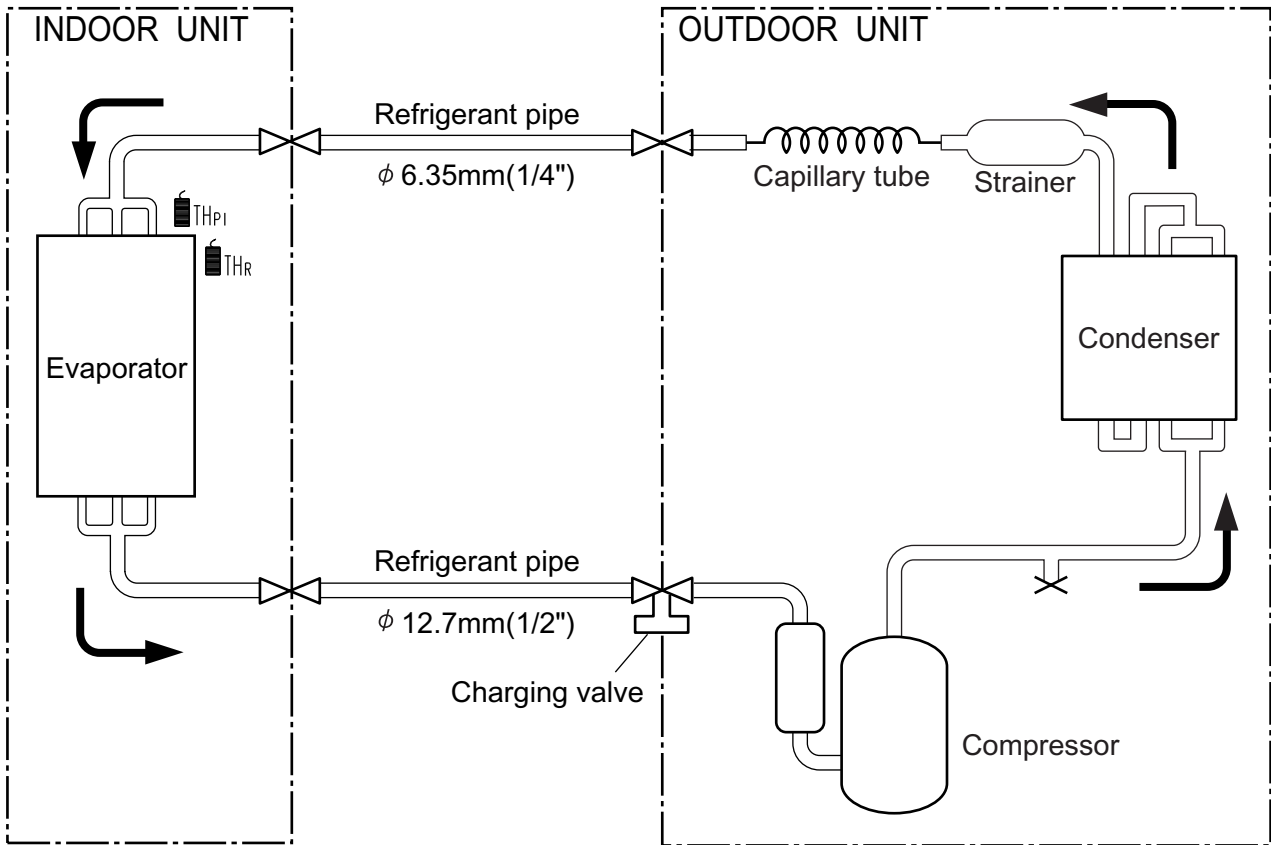

■ MODELS : AU*18U / AO*18U

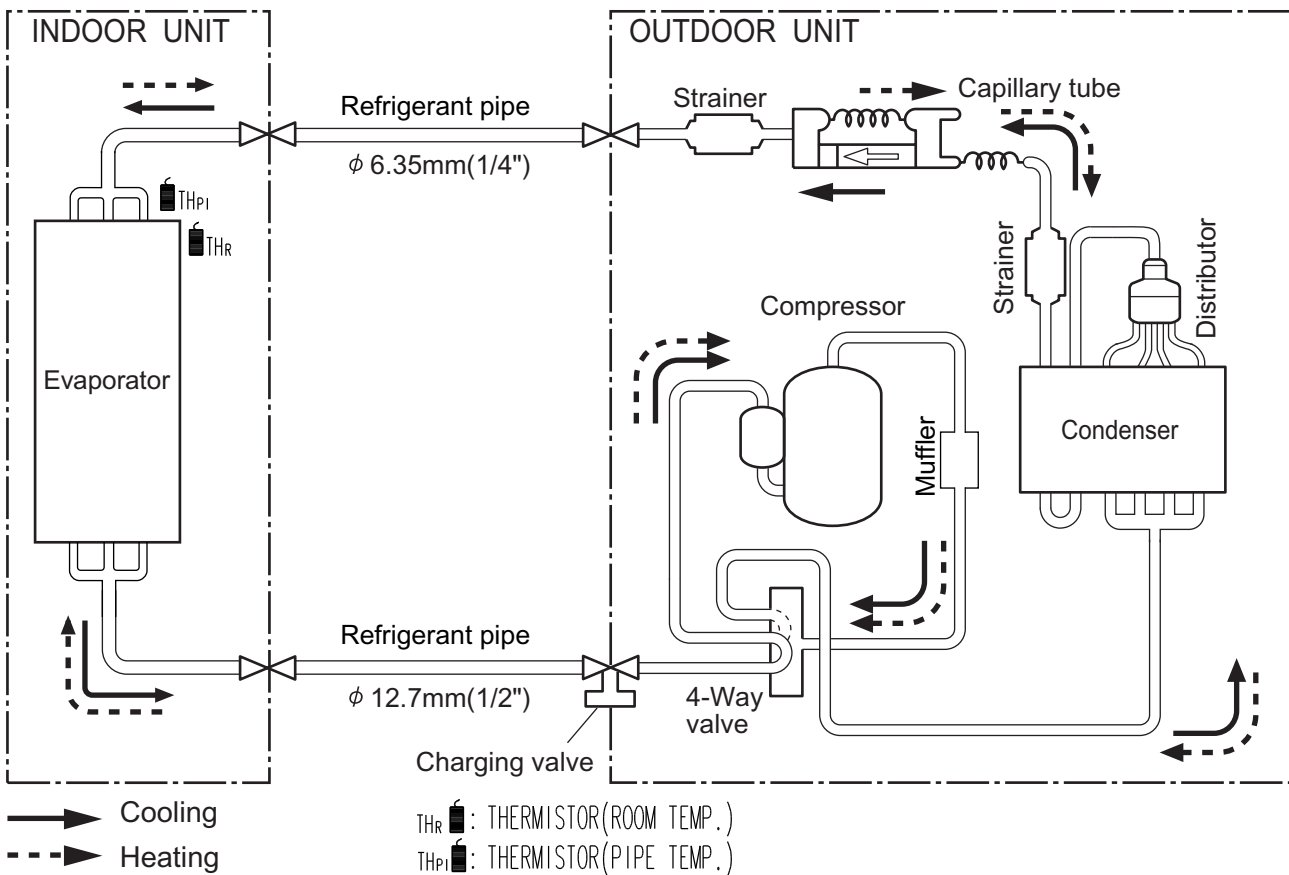

2-6. WIRING DIAGRAMS

2-6-1. OUTDOOR UNIT

■ MODELS : AO*12F, AO*14F

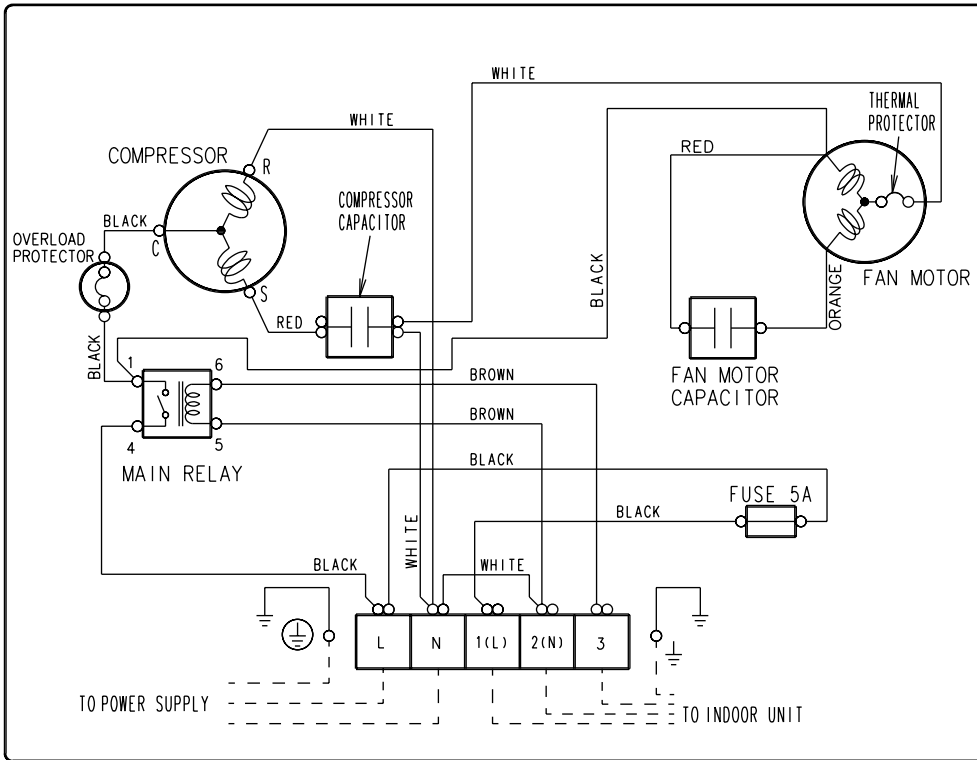

■ MODELS : AO*12U, AO*14U

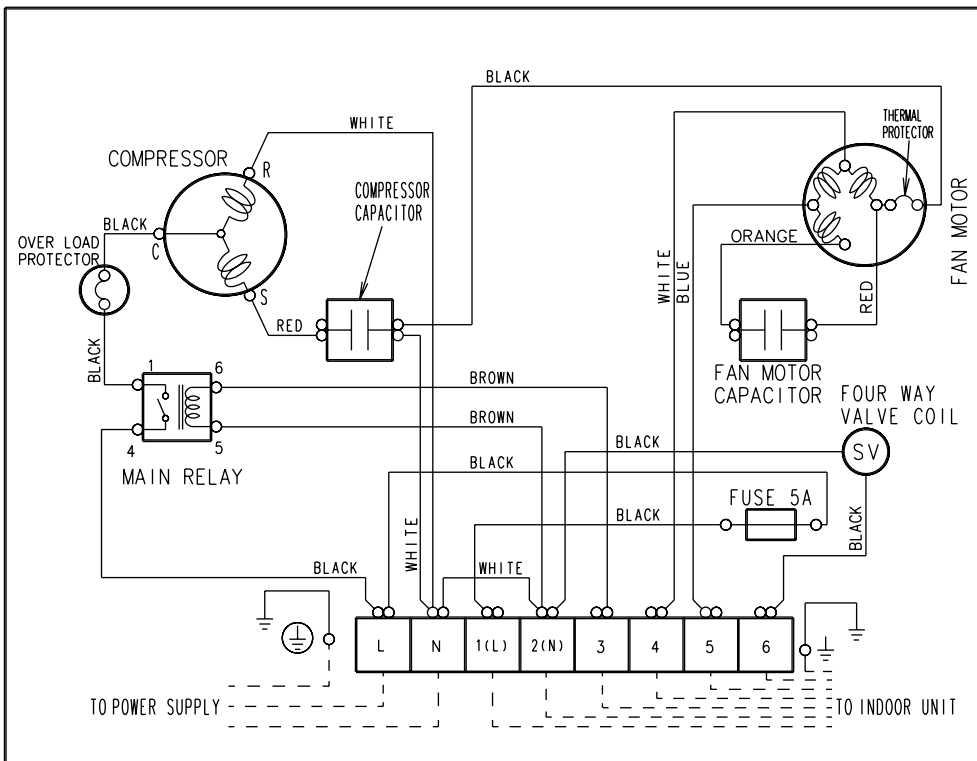

■ MODEL : AO*18F

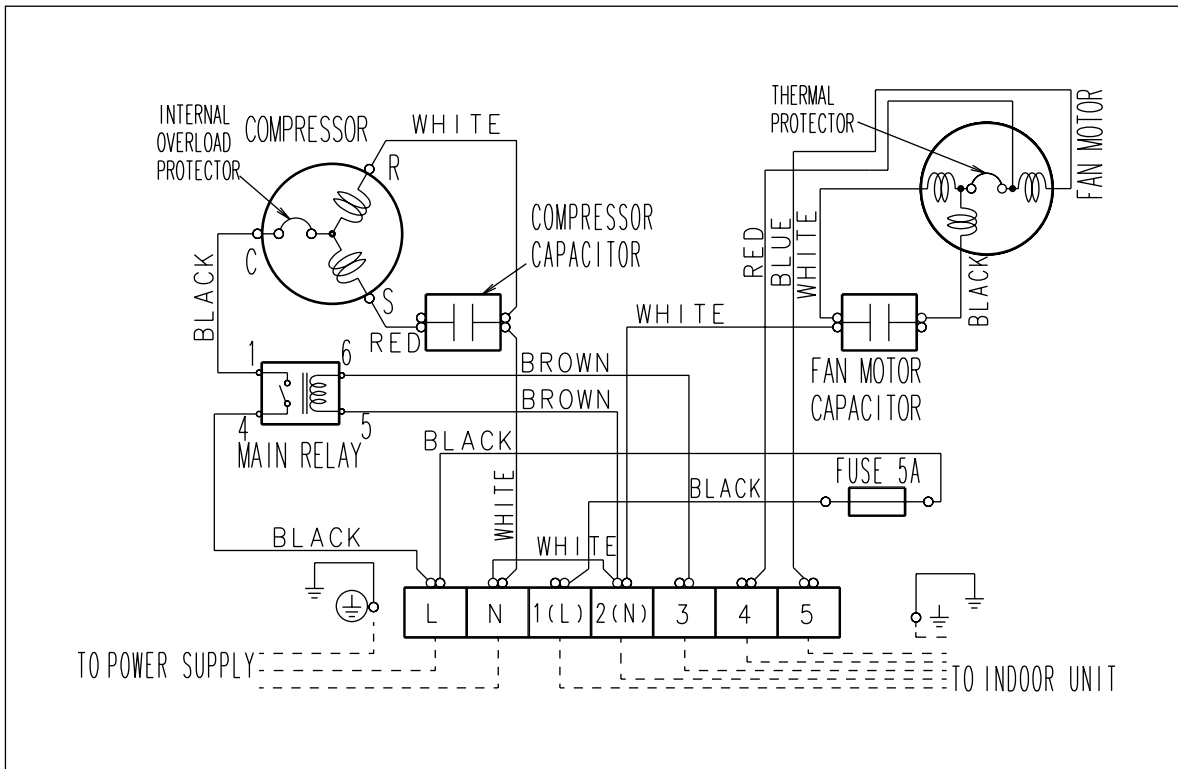

■ MODEL : AO*18U

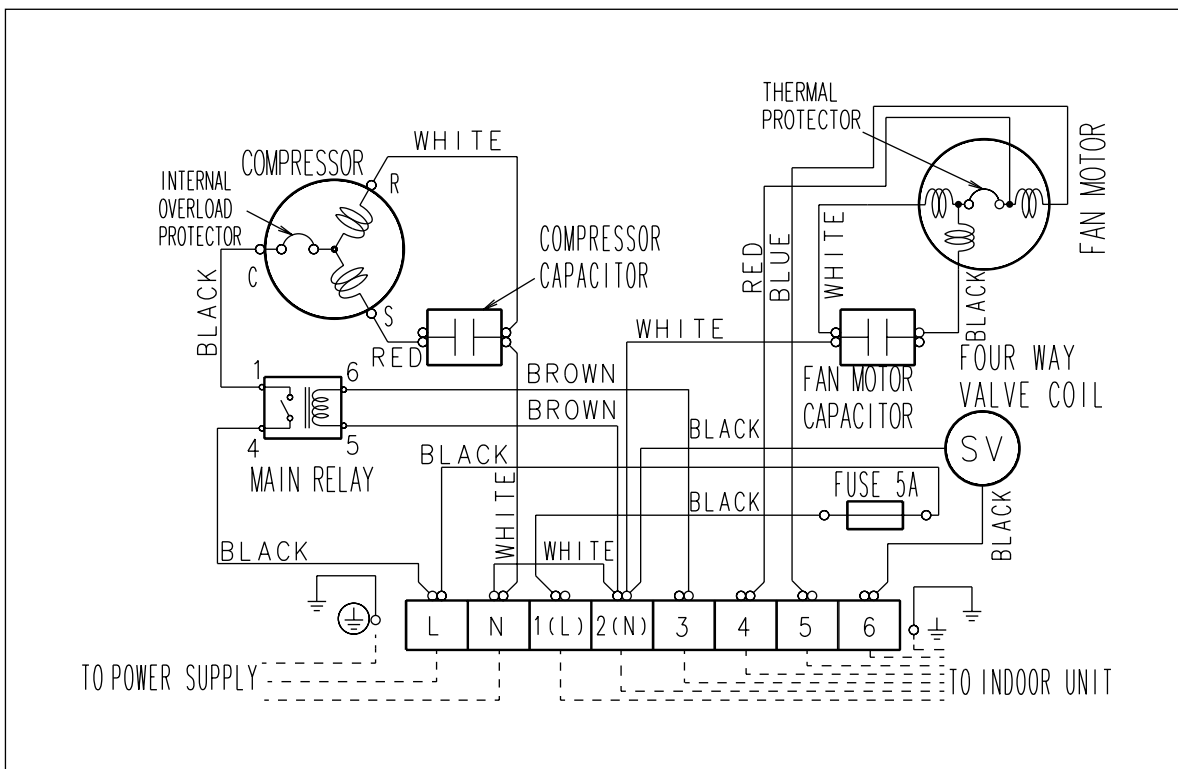

2-6-2. INDOOR UNIT

MODELS : AU *12F, AU *14F

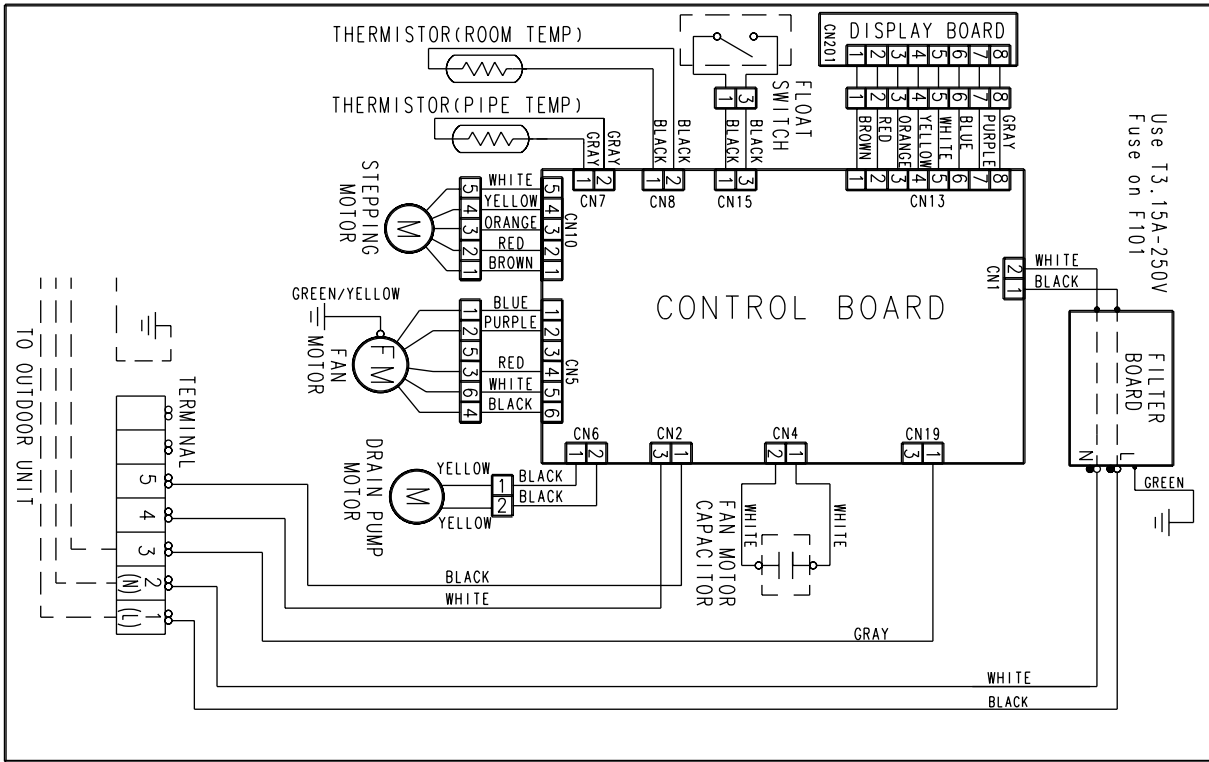

MODELS : AU *12U, AU *14U

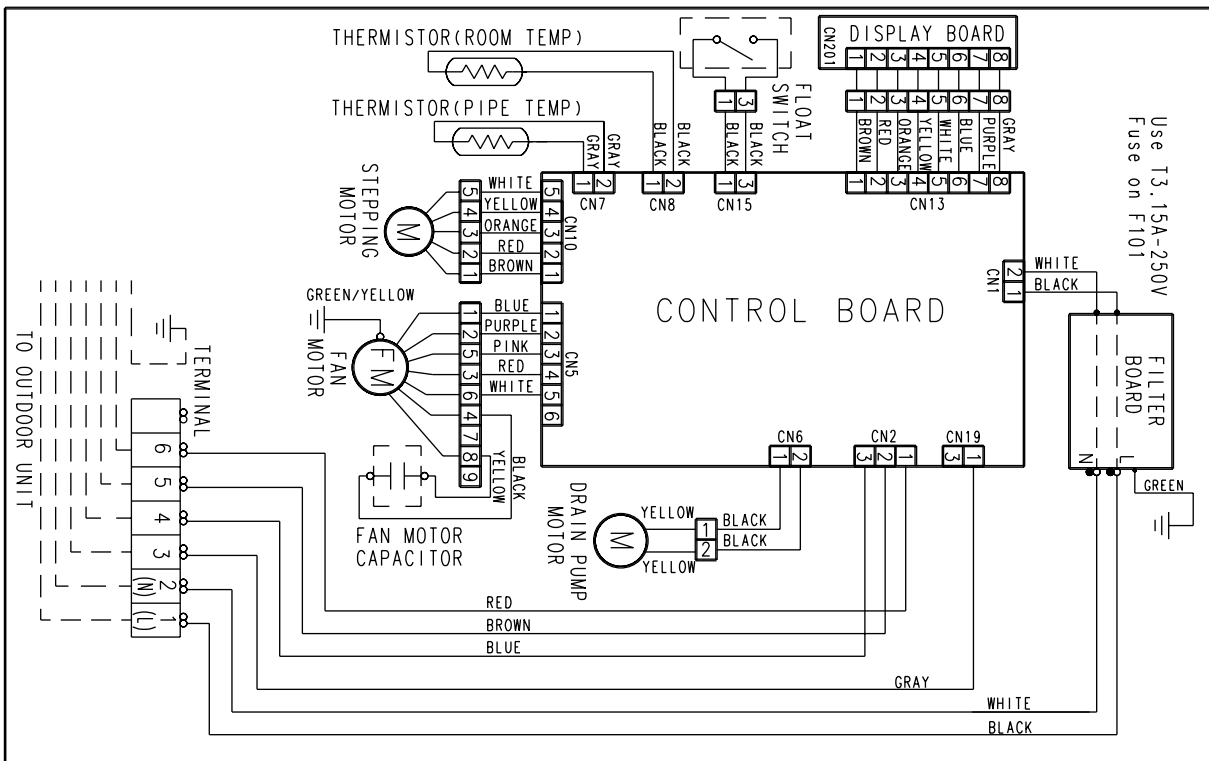

■ MODEL : AU *18F

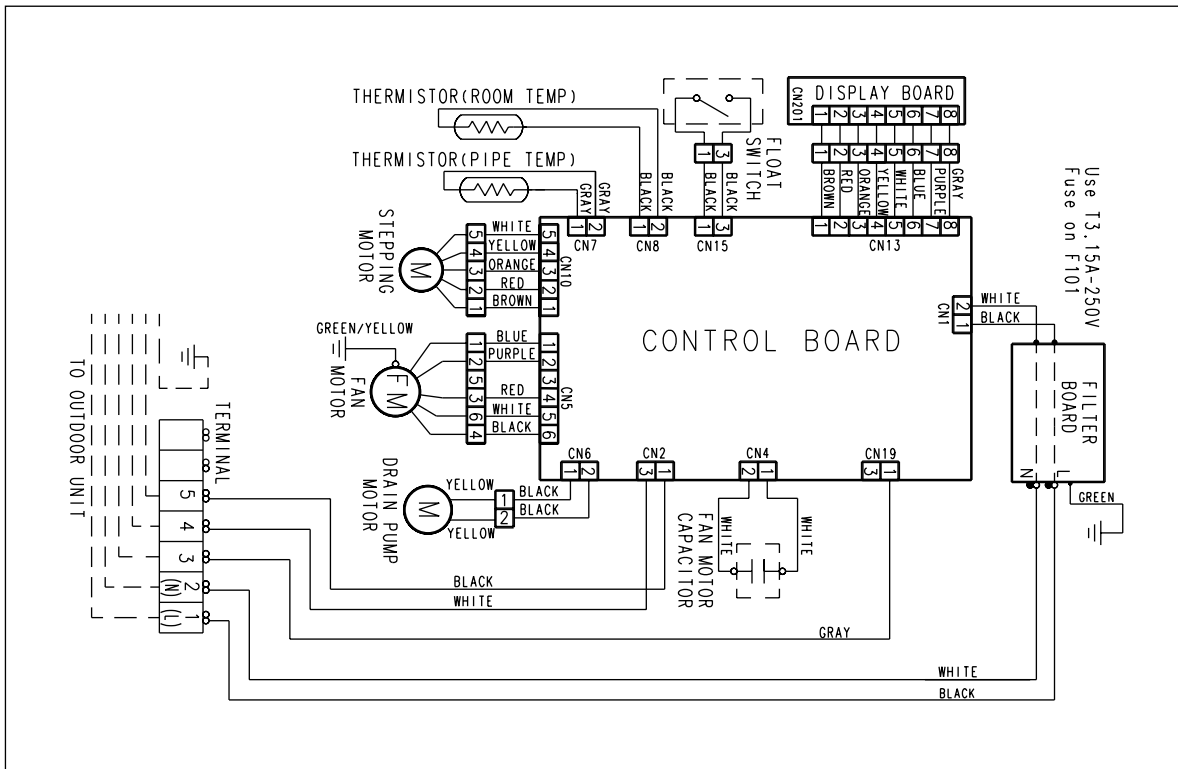

■ MODEL : AU *18U

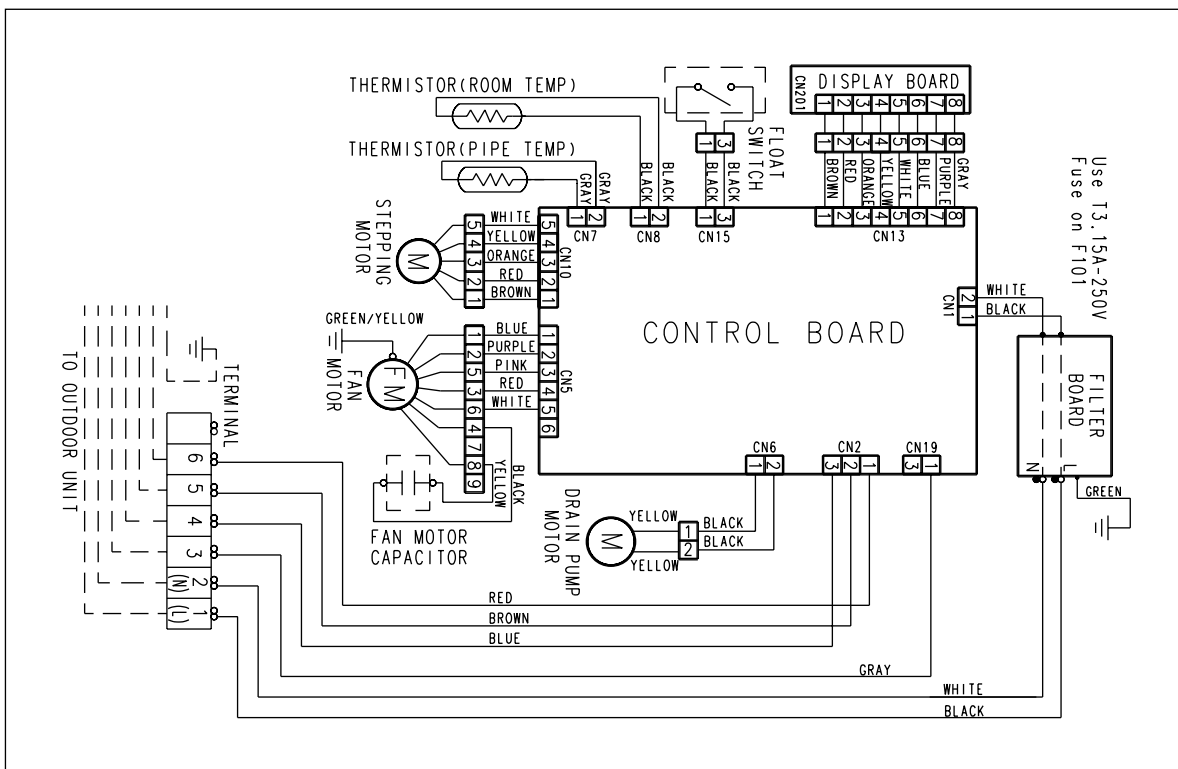

2-7. CAPACITY TABLE

MODELS : AU*12F / AO*12F

COOLING

AFR 9.2

Outdoor temperature		Indoor temperature																							
		18°CDB			21°CDB			23°CDB			26°CDB			27°CDB			29°CDB			30°CDB			32°CDB		
		TC	SHC	PI	TC	SHC	PI	TC	SHC	PI	TC	SHC	PI	TC	SHC	PI	TC	SHC	PI	TC	SHC	PI	TC	SHC	PI
21	3.82	2.82	0.95	3.92	2.83	0.96	4.01	2.85	0.97	4.15	3.00	0.99	4.22	2.99	0.99	4.33	2.96	1.00	4.39	2.94	1.01	4.44	3.08	1.02	
25	3.75	2.76	1.00	3.84	2.77	1.01	3.93	2.79	1.02	4.07	2.95	1.04	4.14	2.93	1.04	4.25	2.90	1.06	4.30	2.89	1.06	4.35	3.02	1.07	
30	3.51	2.63	1.10	3.61	2.65	1.11	3.69	2.68	1.12	3.83	2.84	1.13	3.89	2.83	1.14	4.00	2.80	1.16	4.06	2.79	1.16	4.11	2.93	1.17	
35	3.26	2.52	1.20	3.32	2.54	1.20	3.41	2.56	1.21	3.54	2.71	1.23	3.60	2.71	1.24	3.72	2.69	1.26	3.77	2.68	1.26	3.83	2.83	1.27	
40	2.97	2.40	1.30	3.01	2.41	1.30	3.08	2.42	1.31	3.21	2.57	1.33	3.27	2.57	1.34	3.38	2.56	1.36	3.44	2.55	1.37	3.49	2.71	1.39	
43	2.76	2.29	1.36	2.81	2.31	1.36	2.87	2.32	1.37	3.00	2.49	1.39	3.06	2.48	1.40	3.17	2.48	1.42	3.23	2.48	1.43	3.29	2.63	1.44	

MODELS : AU*14F / AO*14F

COOLING

AFR 9.2

Outdoor temperature		Indoor temperature																							
		18°CDB			21°CDB			23°CDB			26°CDB			27°CDB			29°CDB			30°CDB			32°CDB		
		TC	SHC	PI	TC	SHC	PI	TC	SHC	PI	TC	SHC	PI	TC	SHC	PI	TC	SHC	PI	TC	SHC	PI	TC	SHC	PI
21	4.35	3.19	1.07	4.46	3.21	1.08	4.56	3.23	1.09	4.73	3.41	1.10	4.80	3.39	1.11	4.93	3.36	1.13	4.99	3.34	1.13	5.05	3.50	1.14	
25	4.27	3.13	1.12	4.37	3.15	1.14	4.47	3.16	1.15	4.64	3.34	1.16	4.71	3.33	1.17	4.84	3.29	1.19	4.90	3.27	1.19	4.95	3.43	1.20	
30	4.00	2.99	1.23	4.11	3.01	1.24	4.20	3.04	1.25	4.36	3.22	1.27	4.43	3.21	1.28	4.56	3.18	1.30	4.62	3.16	1.30	4.68	3.33	1.31	
35	3.72	2.86	1.34	3.79	2.88	1.35	3.88	2.90	1.36	4.03	3.08	1.38	4.10	3.07	1.39	4.23	3.05	1.41	4.29	3.04	1.42	4.36	3.21	1.43	
40	3.38	2.72	1.46	3.43	2.73	1.46	3.51	2.74	1.47	3.66	2.92	1.49	3.73	2.92	1.50	3.85	2.90	1.53	3.92	2.90	1.54	3.98	3.07	1.56	
43	3.14	2.59	1.52	3.20	2.62	1.53	3.27	2.64	1.54	3.41	2.82	1.56	3.48	2.82	1.57	3.61	2.81	1.59	3.68	2.81	1.60	3.75	2.99	1.61	

MODELS : AU*18F / AO*18F

COOLING

AFR 10.3

Outdoor temperature		Indoor temperature																							
		18°CDB			21°CDB			23°CDB			26°CDB			27°CDB			29°CDB			30°CDB			32°CDB		
		TC	SHC	PI	TC	SHC	PI	TC	SHC	PI	TC	SHC	PI	TC	SHC	PI	TC	SHC	PI	TC	SHC	PI	TC	SHC	PI
0	5.71	4.02	1.19	5.82	4.04	1.22	5.93	4.05	1.23	6.10	4.22	1.25	6.18	4.19	1.26	6.31	4.11	1.27	6.37	4.07	1.28	6.42	4.24	1.29	
5	5.51	3.91	1.34	5.63	3.93	1.36	5.77	3.94	1.38	5.97	4.14	1.40	6.05	4.12	1.41	6.20	4.06	1.43	6.27	4.03	1.44	6.33	4.20	1.45	
10	5.27	3.77	1.47	5.40	3.79	1.51	5.53	3.82	1.52	5.76	4.03	1.55	5.85	4.02	1.57	6.00	3.97	1.59	6.07	3.94	1.60	6.14	4.12	1.61	
15	5.02	3.64	1.62	5.14	3.66	1.65	5.27	3.69	1.67	5.48	3.91	1.71	5.57	3.89	1.72	5.73	3.86	1.75	5.80	3.83	1.76	5.87	4.02	1.78	
20	5.00	3.52	1.77	5.12	3.54	1.80	5.24	3.56	1.82	5.44	3.77	1.86	5.52	3.76	1.87	5.68	3.72	1.91	5.76	3.71	1.92	5.83	3.89	1.94	
25	5.20	3.63	1.54	5.33	3.64	1.55	5.45	3.67	1.57	5.66	3.87	1.59	5.74	3.86	1.60	5.90	3.81	1.62	5.97	3.79	1.63	6.04	3.97	1.64	
30	4.87	3.46	1.68	5.01	3.48	1.70	5.13	3.52	1.71	5.32	3.73	1.74	5.40	3.72	1.75	5.56	3.68	1.77	5.64	3.67	1.78	5.71	3.85	1.79	
35	4.53	3.32	1.84	4.62	3.34	1.84	4.74	3.36	1.86	4.92	3.56	1.89	5.00	3.56	1.90	5.16	3.53	1.93	5.24	3.52	1.94	5.31	3.72	1.95	
40	4.12	3.15	1.99	4.19	3.16	2.00	4.28	3.18	2.01	4.46	3.38	2.04	4.54	3.38	2.05	4.70	3.36	2.09	4.78	3.36	2.10	4.85	3.56	2.13	
43	3.83	3.01	2.08	3.90	3.04	2.09	3.99	3.05	2.10	4.16	3.27	2.13	4.25	3.26	2.15	4.40	3.26	2.18	4.49	3.26	2.19	4.57	3.46	2.21	

AFR: Air flow rate (m³/min)

TC : Total capacity (kW)

SHC: Sensible Heat capacity (kW)

PI : Power Input (kW)

MODELS : AU*12U / AO*12U

COOLING

AFR 9.2

		Indoor temperature																							
		18 °CDB			21 °CDB			23 °CDB			26 °CDB			27 °CDB			29 °CDB			30 °CDB			32 °CDB		
		12 °CWB			15 °CWB			16 °CWB			18 °CWB			19 °CWB			21 °CWB			22 °CWB			23 °CWB		
Outdoor temperature	(°CDB)	TC	SHC	PI	TC	SHC	PI	TC	SHC	PI	TC	SHC	PI	TC	SHC	PI	TC	SHC	PI	TC	SHC	PI	TC	SHC	PI
	0	4.05	3.00	0.78	4.13	3.01	0.80	4.21	3.03	0.80	4.33	3.15	0.82	4.39	3.13	0.82	4.48	3.07	0.83	4.52	3.04	0.84	4.56	3.17	0.84
	5	3.91	2.92	0.87	4.00	2.93	0.89	4.10	2.94	0.90	4.24	3.09	0.92	4.30	3.08	0.92	4.40	3.03	0.94	4.45	3.01	0.94	4.50	3.14	0.95
	10	3.74	2.82	0.96	3.84	2.83	0.98	3.93	2.85	1.00	4.09	3.01	1.01	4.15	3.00	1.02	4.26	2.97	1.04	4.31	2.95	1.05	4.36	3.08	1.05
	15	3.57	2.72	1.06	3.65	2.74	1.08	3.75	2.75	1.09	3.89	2.92	1.11	3.96	2.91	1.12	4.07	2.88	1.14	4.12	2.86	1.15	4.17	3.00	1.16
	20	3.55	2.63	1.16	3.63	2.64	1.18	3.72	2.66	1.19	3.86	2.82	1.21	3.92	2.81	1.22	4.04	2.78	1.24	4.09	2.77	1.25	4.14	2.91	1.26
	25	3.69	2.71	1.00	3.79	2.72	1.01	3.87	2.74	1.02	4.02	2.89	1.04	4.08	2.88	1.04	4.19	2.85	1.06	4.24	2.83	1.06	4.29	2.97	1.07
	30	3.46	2.59	1.10	3.56	2.60	1.11	3.64	2.63	1.12	3.78	2.78	1.13	3.84	2.78	1.14	3.95	2.75	1.16	4.00	2.74	1.16	4.05	2.88	1.17
	35	3.22	2.48	1.20	3.28	2.50	1.20	3.36	2.51	1.21	3.49	2.66	1.23	3.55	2.66	1.24	3.66	2.64	1.26	3.72	2.63	1.26	3.77	2.78	1.27
	40	2.93	2.35	1.30	2.97	2.36	1.30	3.04	2.37	1.31	3.17	2.53	1.33	3.23	2.52	1.34	3.34	2.51	1.36	3.39	2.51	1.37	3.45	2.66	1.39
43	2.72	2.24	1.36	2.77	2.27	1.36	2.83	2.28	1.37	2.96	2.44	1.39	3.02	2.44	1.40	3.13	2.43	1.42	3.19	2.43	1.43	3.25	2.58	1.44	

HEATING

AFR 9.2

		Indoor temperature														
		16 °CDB		18 °CDB		20 °CDB		23 °CDB		25 °CDB		27 °CDB		30 °CDB		
Outdoor temperature	(°CDB) (°CWB)	TC	PI	TC	PI	TC	PI	TC	PI	TC	PI	TC	PI	TC	PI	
	-7	-9	2.60	0.91	2.56	0.94	2.48	0.97	2.40	1.00	2.36	1.02	2.28	1.05	2.20	1.06
	-4	-6	2.84	0.99	2.80	1.02	2.72	1.05	2.64	1.07	2.60	1.09	2.52	1.12	2.44	1.13
	1	-1	3.20	1.12	3.16	1.15	3.08	1.18	3.00	1.21	2.96	1.22	2.88	1.25	2.80	1.26
	5	3	3.92	1.15	3.88	1.17	3.80	1.20	3.72	1.22	3.68	1.23	3.60	1.26	3.52	1.27
	7	6	4.12	1.16	4.08	1.19	4.00	1.21	3.92	1.23	3.88	1.25	3.80	1.27	3.72	1.28
	12	10	4.40	1.25	4.36	1.27	4.28	1.29	4.20	1.32	4.16	1.33	4.08	1.36	4.00	1.37
	15	13	4.44	1.29	4.40	1.32	4.32	1.34	4.24	1.37	4.20	1.38	4.12	1.40	4.04	1.42
	20	15	4.12	1.16	4.08	1.19	4.00	1.21	3.92	1.23	3.88	1.25	3.80	1.27	3.72	1.28
	24	17	3.88	1.09	3.84	1.11	3.76	1.14	3.68	1.16	3.64	1.17	3.56	1.20	3.48	1.21

MODELS : AU*14U / AO*14U

COOLING

AFR 9.2

		Indoor temperature																							
		18 °CDB			21 °CDB			23 °CDB			26 °CDB			27 °CDB			29 °CDB			30 °CDB			32 °CDB		
		12 °CWB			15 °CWB			16 °CWB			18 °CWB			19 °CWB			21 °CWB			22 °CWB			23 °CWB		
Outdoor temperature	(°CDB)	TC	SHC	PI	TC	SHC	PI	TC	SHC	PI	TC	SHC	PI	TC	SHC	PI	TC	SHC	PI	TC	SHC	PI	TC	SHC	PI
	0	4.51	3.30	0.88	4.60	3.31	0.90	4.69	3.32	0.91	4.82	3.46	0.92	4.88	3.44	0.93	4.98	3.38	0.94	5.03	3.34	0.94	5.08	3.48	0.95
	5	4.35	3.21	0.99	4.45	3.22	1.00	4.56	3.24	1.02	4.72	3.40	1.03	4.78	3.38	1.04	4.90	3.33	1.06	4.95	3.31	1.06	5.00	3.45	1.07
	10	4.16	3.10	1.09	4.27	3.11	1.11	4.37	3.13	1.12	4.55	3.31	1.14	4.62	3.30	1.15	4.74	3.26	1.17	4.80	3.24	1.18	4.85	3.38	1.19
	15	3.97	2.99	1.19	4.06	3.01	1.22	4.17	3.03	1.23	4.33	3.21	1.26	4.40	3.20	1.27	4.53	3.17	1.29	4.58	3.15	1.30	4.64	3.30	1.31
	20	3.95	2.89	1.31	4.04	2.90	1.33	4.14	2.92	1.34	4.30	3.09	1.37	4.36	3.08	1.38	4.49	3.06	1.40	4.55	3.04	1.42	4.61	3.19	1.43
	25	4.11	2.98	1.13	4.21	2.99	1.14	4.31	3.01	1.15	4.47	3.18	1.17	4.54	3.16	1.18	4.66	3.13	1.19	4.72	3.11	1.20	4.77	3.26	1.21
	30	3.85	2.84	1.24	3.96	2.86	1.25	4.05	2.89	1.26	4.20	3.06	1.28	4.27	3.05	1.29	4.39	3.02	1.31	4.45	3.01	1.31	4.51	3.16	1.32
	35	3.58	2.72	1.35	3.65	2.74	1.36	3.74	2.76	1.37	3.88	2.93	1.39	3.95	2.92	1.40	4.08	2.90	1.42	4.14	2.89	1.43	4.20	3.05	1.44
	40	3.26	2.58	1.47	3.31	2.60	1.47	3.38	2.61	1.48	3.52	2.78	1.50	3.59	2.77	1.51	3.71	2.76	1.54	3.77	2.75	1.55	3.83	2.92	1.57
43	3.03	2.47	1.53	3.08	2.50	1.54	3.15	2.51	1.55	3.29	2.68	1.57	3.36	2.68	1.58	3.48	2.67	1.61	3.55	2.67	1.62	3.61	2.84	1.63	

HEATING

AFR 9.2

		Indoor temperature														
		16 °CDB		18 °CDB		20 °CDB		23 °CDB		25 °CDB		27 °CDB		30 °CDB		
Outdoor temperature	(°CDB) (°CWB)	TC	PI	TC	PI	TC	PI	TC	PI	TC	PI	TC	PI	TC	PI	
	-7	-9	2.99	1.07	2.94	1.11	2.85	1.14	2.76	1.18	2.71	1.19	2.62	1.23	2.53	1.24
	-4	-6	3.27	1.16	3.22	1.19	3.13	1.23	3.04	1.26	2.99	1.28	2.90	1.31	2.81	1.33
	1	-1	3.68	1.31	3.63	1.35	3.54	1.38	3.45	1.41	3.40	1.43	3.31	1.47	3.22	1.48
	5	3	4.51	1.35	4.46	1.38	4.37	1.40	4.28	1.43	4.23	1.45	4.14	1.48	4.05	1.49
	7	6	4.74	1.36	4.69	1.39	4.60	1.42	4.51	1.45	4.46	1.46	4.37	1.49	4.28	1.51
	12	10	5.06	1.46	5.01	1.49	4.92	1.52	4.83	1.55	4.78	1.56	4.69	1.59	4.60	1.60
	15	13	5.11	1.52	5.06	1.55	4.97	1.58	4.88	1.60	4.83	1.62	4.74	1.65	4.65	1.66
	20	15	4.74	1.36	4.69	1.39	4.60	1.42	4.51	1.45	4.46	1.46	4.37	1.49	4.28	1.51
	24	17	4.46	1.28	4.42	1.31	4.32	1.33	4.23	1.36	4.19	1.38	4.09	1.41	4.00	1.42

AFR: Air flow rate (m³/min)

TC : Total capacity (kW)

SHC: Sensible Heat capacity (kW)

PI : Power Input (kW)

CASSETTE TYPE
AU12-18

CASSETTE TYPE
AU12-18

MODELS : AU*18U / AO*18U

COOLING

AFR 10.3

		Indoor temperature																										
		18 °CDB			21 °CDB			23 °CDB			26 °CDB			27 °CDB			29 °CDB			30 °CDB			32 °CDB					
		12 °CWB			15 °CWB			16 °CWB			18 °CWB			19 °CWB			21 °CWB			22 °CWB			23 °CWB					
Outdoor temperature	(°CDB)	TC	SHC	PI	TC	SHC	PI	TC	SHC	PI	TC	SHC	PI	TC	SHC	PI	TC	SHC	PI	TC	SHC	PI	TC	SHC	PI	TC	SHC	PI
	0	5.54	3.85	1.16	5.65	3.87	1.19	5.76	3.88	1.20	5.92	4.04	1.22	5.99	4.01	1.23	6.12	3.94	1.24	6.18	3.90	1.25	6.23	4.06	1.25	6.23	4.06	1.25
	5	5.34	3.74	1.30	5.46	3.76	1.33	5.60	3.78	1.34	5.79	3.97	1.37	5.87	3.95	1.38	6.02	3.89	1.40	6.08	3.86	1.40	6.14	4.03	1.41	6.14	4.03	1.41
	10	5.11	3.62	1.43	5.24	3.63	1.47	5.37	3.65	1.48	5.58	3.86	1.51	5.67	3.85	1.53	5.82	3.80	1.55	5.89	3.78	1.56	5.96	3.95	1.57	5.96	3.95	1.57
	15	4.87	3.49	1.57	4.99	3.51	1.61	5.12	3.53	1.63	5.32	3.74	1.66	5.40	3.73	1.68	5.56	3.69	1.70	5.63	3.67	1.72	5.69	3.85	1.73	5.69	3.85	1.73
	20	4.85	3.37	1.73	4.96	3.39	1.75	5.08	3.41	1.77	5.27	3.61	1.81	5.36	3.60	1.82	5.51	3.57	1.86	5.59	3.55	1.87	5.66	3.73	1.88	5.66	3.73	1.88
	25	5.05	3.48	1.50	5.17	3.49	1.51	5.29	3.51	1.53	5.49	3.71	1.55	5.57	3.69	1.56	5.72	3.65	1.58	5.79	3.63	1.59	5.86	3.81	1.60	5.86	3.81	1.60
	30	4.73	3.32	1.64	4.86	3.34	1.65	4.97	3.38	1.67	5.16	3.57	1.69	5.24	3.56	1.70	5.40	3.53	1.73	5.47	3.51	1.74	5.54	3.69	1.75	5.54	3.69	1.75
	35	4.40	3.18	1.79	4.48	3.20	1.80	4.59	3.22	1.81	4.77	3.41	1.84	4.85	3.41	1.85	5.01	3.38	1.87	5.08	3.37	1.89	5.15	3.56	1.90	5.15	3.56	1.90
	40	4.00	3.02	1.94	4.06	3.03	1.95	4.16	3.04	1.96	4.32	3.24	1.99	4.41	3.24	2.00	4.56	3.22	2.03	4.63	3.21	2.04	4.71	3.41	2.07	4.71	3.41	2.07
43	3.72	2.88	2.03	3.78	2.91	2.03	3.87	2.93	2.05	4.04	3.13	2.07	4.12	3.13	2.09	4.27	3.12	2.12	4.36	3.12	2.13	4.44	3.31	2.15	4.44	3.31	2.15	

HEATING

AFR 10.3

		Indoor temperature														
		16 °CDB		18 °CDB		20 °CDB		23 °CDB		25 °CDB		27 °CDB		30 °CDB		
Outdoor temperature	(°CDB) (°CWB)	TC	PI	TC	PI	TC	PI	TC	PI	TC	PI	TC	PI	TC	PI	
	-7	-9	3.51	1.51	3.46	1.56	3.35	1.61	3.24	1.66	3.19	1.68	3.08	1.73	2.97	1.75
	-4	-6	3.83	1.63	3.78	1.68	3.67	1.73	3.56	1.78	3.51	1.80	3.40	1.85	3.29	1.87
	1	-1	4.32	1.85	4.27	1.90	4.16	1.94	4.05	1.99	4.00	2.02	3.89	2.06	3.78	2.09
	5	3	5.29	1.90	5.24	1.94	5.13	1.98	5.02	2.02	4.97	2.04	4.86	2.08	4.75	2.10
	7	6	5.56	1.92	5.51	1.96	5.40	2.00	5.29	2.04	5.24	2.06	5.13	2.10	5.02	2.12
	12	10	5.94	2.06	5.89	2.10	5.78	2.14	5.67	2.18	5.62	2.20	5.51	2.24	5.40	2.26
	15	13	5.99	2.14	5.94	2.18	5.83	2.22	5.72	2.26	5.67	2.28	5.56	2.32	5.45	2.34
	20	15	5.56	1.92	5.51	1.96	5.40	2.00	5.29	2.04	5.24	2.06	5.13	2.10	5.02	2.12
	24	17	5.24	1.80	5.18	1.84	5.08	1.88	4.97	1.92	4.91	1.94	4.81	1.98	4.70	2.00

AFR: Air flow rate (m³/min)

TC : Total capacity (kW)

SHC: Sensible Heat capacity (kW)

PI : Power Input (kW)

2-8. CAPACITY COMPENSATION FOR PIPE LENGTH AND HEIGHT DIFFERENCE

■ MODELS : AU*12F / AO*12F, AU*14F / AO*14F, AU*18F / AO*18F

CASSETTE TYPE
AU12-18

COOLING		PIPE LENGTH (m)					
		5	7.5	10	15	20	
HEIGHT DIFFERENCE (m)	Outdoor unit is bottom-side		-	-	-	-	-
			-	-	-	-	-
	8	-	1.000	0.985	0.952	0.919	
	5	1.010	1.000	0.985	0.952	0.919	
	0	1.010	1.000	0.985	0.952	0.919	
	Outdoor unit is up-side	-5	1.002	0.992	0.977	0.944	0.912
		-8	-	0.988	0.973	0.941	0.908
			-	-	-	-	-
			-	-	-	-	-

CASSETTE TYPE
AU12-18

■ MODELS : AU *12U / AO *12U, AU *14U / AO *14U, AU *18U / AO *18U

CASSETTE TYPE
AU12-18

CASSETTE TYPE
AU12-18

COOLING			PIPE LENGTH (m)					
			5	7.5	10	15	20	
HEIGHT DIFFERENCE (m)	Outdoor unit is bottom-side		-	-	-	-	-	
			-	-	-	-	-	
		8	-	1.000	0.985	0.952	0.919	
		5	1.010	1.000	0.985	0.952	0.919	
		0	1.010	1.000	0.985	0.952	0.919	
	Outdoor unit is up-side		-5	1.002	0.992	0.977	0.944	0.912
			-8	-	0.988	0.973	0.941	0.908
				-	-	-	-	-
				-	-	-	-	-
				-	-	-	-	-
			-	-	-	-	-	

HEATING			PIPE LENGTH (m)					
			5	7.5	10	15	20	
HEIGHT DIFFERENCE (m)	Outdoor unit is bottom-side		-	-	-	-	-	
			-	-	-	-	-	
		8	-	0.993	0.982	0.964	0.946	
		5	1.005	0.995	0.984	0.966	0.948	
		0	1.010	1.000	0.989	0.971	0.953	
	Outdoor unit is up-side		-5	1.010	1.000	0.989	0.971	0.953
			-8	-	1.000	0.989	0.971	0.953
				-	-	-	-	-
				-	-	-	-	-
				-	-	-	-	-
			-	-	-	-	-	

2-9. ADDITIONAL CHARGE CALCULATION

■ MODELS : AU*12F / AO*12F

REFRIGERANT TYPE		R410A			
REFRIGERANT AMOUNT	g	800			

● REFRIGERANT CHARGE

PIPE LENGTH	m	~7.5	10	15	20(max)	10g/m
ADDITIONAL CHARGE	g	0 (Charge less)	+25	+75	+125	

■ MODELS : AU*14F / AO*14F

REFRIGERANT TYPE		R410A			
REFRIGERANT AMOUNT	g	900			

● REFRIGERANT CHARGE

PIPE LENGTH	m	~7.5	10	15	20(max)	10g/m
ADDITIONAL CHARGE	g	0 (Charge less)	+25	+75	+125	

■ MODELS : AU*18F / AO*18F

REFRIGERANT TYPE		R410A			
REFRIGERANT AMOUNT	g	800			

● REFRIGERANT CHARGE

PIPE LENGTH	m	~7.5	10	15	20(max)	20g/m
ADDITIONAL CHARGE	g	0 (Charge less)	+50	+150	+250	

■ **MODELS : AU*12U / AO*12U**

REFRIGERANT TYPE		R410A			
REFRIGERANT AMOUNT	g	850			

● **REFRIGERANT CHARGE**

PIPE LENGTH	m	~7.5	10	15	20(max)	10g/m
ADDITIONAL CHARGE	g	0 (Charge less)	+25	+75	+125	

■ **MODELS : AU*14U / AO*14U**

REFRIGERANT TYPE		R410A			
REFRIGERANT AMOUNT	g	1000			

● **REFRIGERANT CHARGE**

PIPE LENGTH	m	~7.5	10	15	20(max)	10g/m
ADDITIONAL CHARGE	g	0 (Charge less)	+25	+75	+125	

■ **MODELS : AU*18U / AO*18U**

REFRIGERANT TYPE		R410A			
REFRIGERANT AMOUNT	g	1250			

● **REFRIGERANT CHARGE**

PIPE LENGTH	m	~7.5	10	15	20(max)	20g/m
ADDITIONAL CHARGE	g	0 (Charge less)	+50	+150	+250	

2-10. OPERATION RANGE

CASSETTE TYPE
AU12-18

Model		Mode	Operation Range		
Indoor unit	Outdoor unit		Indoor temperature	Indoor humidity	Outdoor temperature
AU * 12F AU * 14F	AO * 12F AO * 14F	Cooling Dry	18 to 32 °C	About 80% or less	21 to 43 °C
AU * 18F	AO * 18F				0 to 43°C

CASSETTE TYPE
AU12-18

Model		Mode	Operation Range		
Indoor unit	Outdoor unit		Indoor temperature	Indoor humidity	Outdoor temperature
AU * 12U AU * 14U AU * 18U	AO * 12U AO * 14U AO * 18U	Cooling Dry	18 to 32 °C	About 80% or less	0 to 43 °C
		Heating	16 to 30 °C	-	-7 to 24 °C

2-11. FAN PERFORMANCE AND AIR FLOW

2-11-1. AIR VELOCITY DISTRIBUTION

■ MODELS : AU * 12F, AU * 12U, AU * 14F, AU * 14U

CASSETTE TYPE
AU12-18

CASSETTE TYPE
AU12-18

4-WAY AIR OUTLET

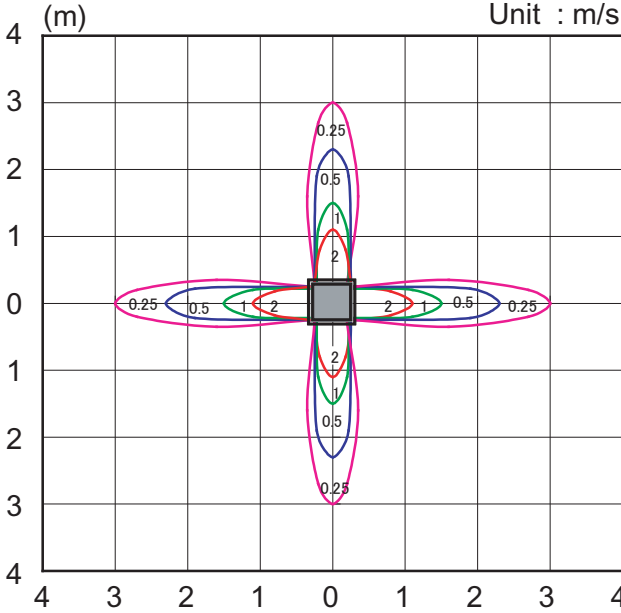

Note :
Condition
Fan speed : High
Operation mode :FAN

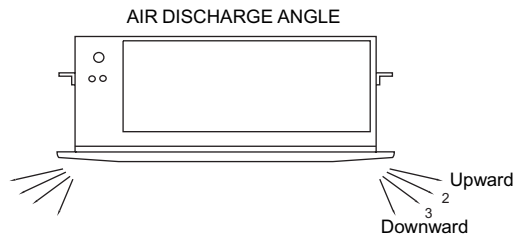
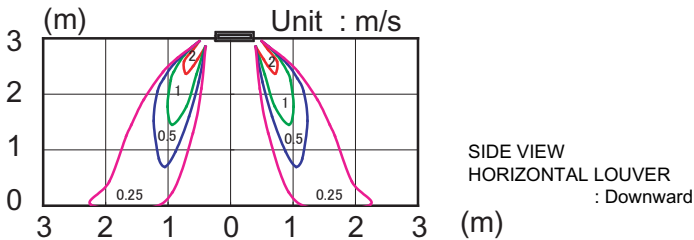
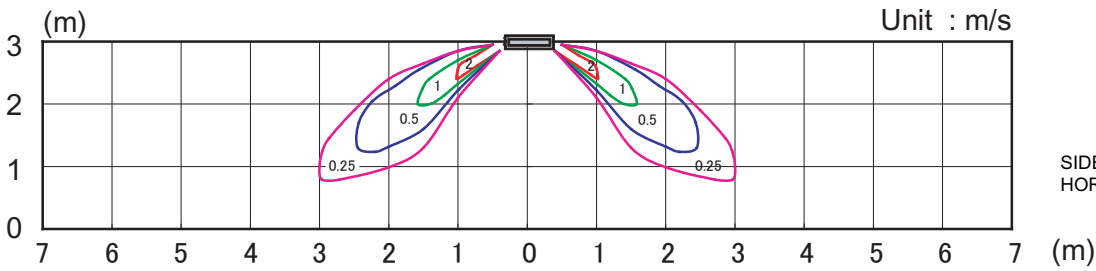

2-WAY AIR OUTLET

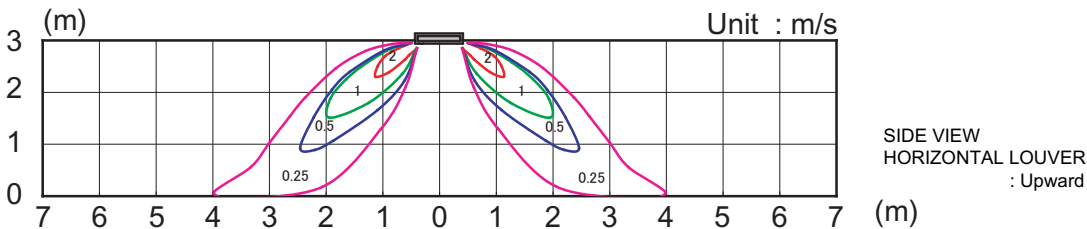
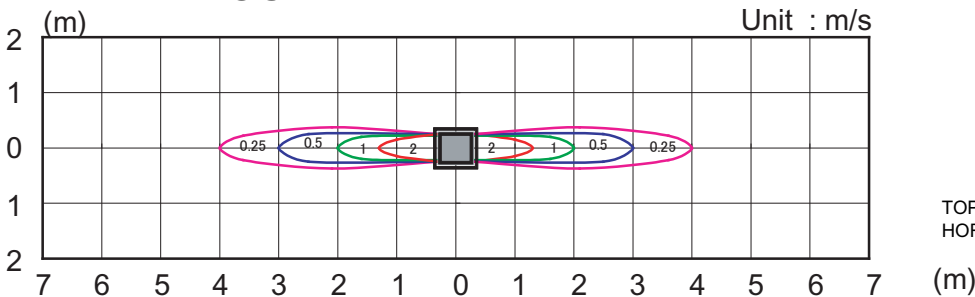

MODELS : AU*18F, AU*18U

4-WAY AIR OUTLET

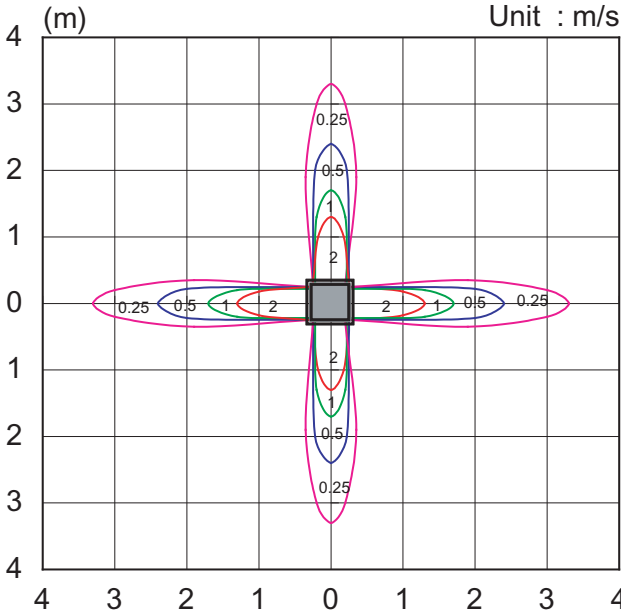

Note :
Condition
Fan speed : High
Operation mode : FAN

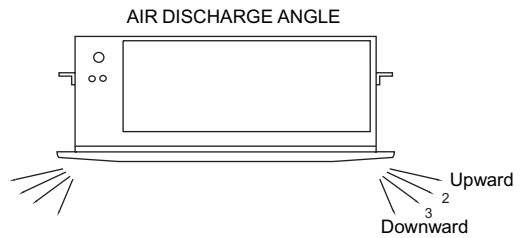
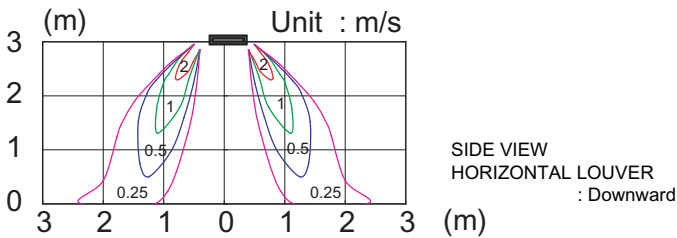
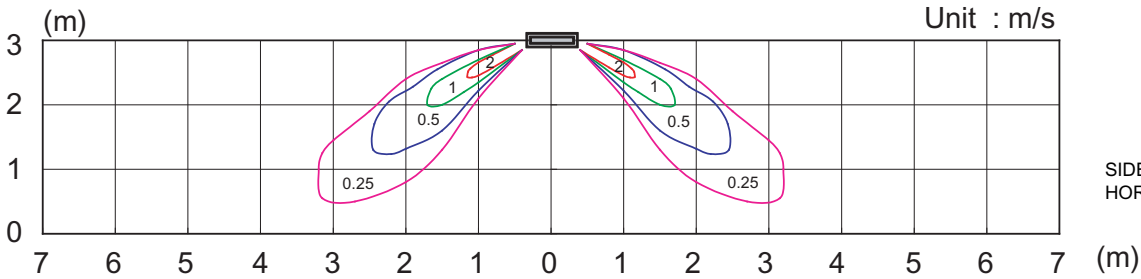

2-WAY AIR OUTLET

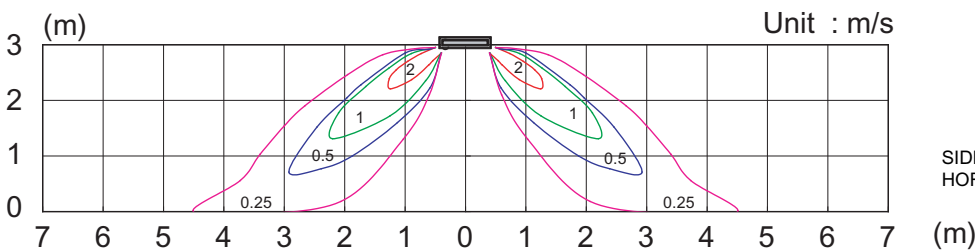
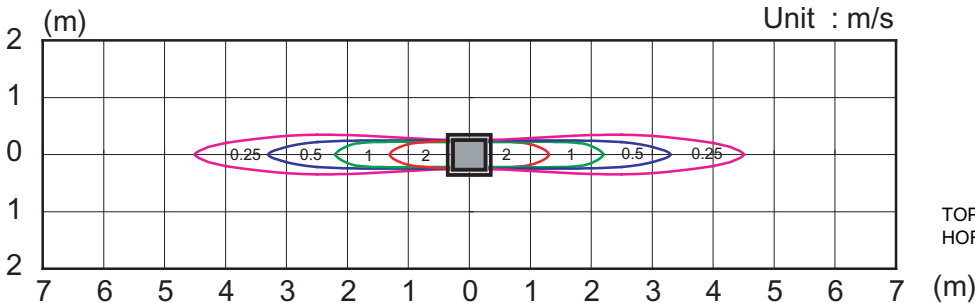

2-11-2. AIR FLOW

■ MODELS : AU*12F / AO*12F, AU*14F / AO*14F

CASSETTE TYPE
AU12-18

	FAN SPEED	NUMBER OF ROTATIONS (r.p.m)	AIR FLOW	
Indoor unit	HIGH	750	m ³ /h	550
			l/s	153
			CFM	324
	MED	670	m ³ /h	500
			l/s	139
			CFM	294
	LOW	590	m ³ /h	440
			l/s	122
			CFM	259
Outdoor unit	HIGH	740	m ³ /h	1600
			l/s	444
			CFM	942

CASSETTE TYPE
AU12-18

■ MODELS : AU*12U / AO*12U, AU*14U / AO*14U

	FAN SPEED	NUMBER OF ROTATIONS (r.p.m)	AIR FLOW	
Indoor unit	HIGH	730	m ³ /h	550
			l/s	153
			CFM	324
	MED	670	m ³ /h	500
			l/s	139
			CFM	294
	LOW	590	m ³ /h	440
			l/s	122
			CFM	259
Outdoor unit	HIGH	740	m ³ /h	1600
			l/s	444
			CFM	942
	LOW	440	m ³ /h	-
			l/s	-
			CFM	-

■ MODELS : AU*18F / AO*18F

	FAN SPEED	NUMBER OF ROTATIONS (r.p.m)	AIR FLOW	
Indoor unit	HIGH	800	m ³ /h	620
			l/s	172
			CFM	365
	MED	700	m ³ /h	520
			l/s	144
			CFM	306
	LOW	600	m ³ /h	450
			l/s	125
			CFM	265
Outdoor unit	HIGH	780	m ³ /h	3400
			l/s	944
			CFM	2001
	LOW	400	m ³ /h	-
			l/s	-
			CFM	-

■ MODELS : AU*18U / AO*18U

	FAN SPEED	NUMBER OF ROTATIONS (r.p.m)	AIR FLOW	
Indoor unit	HIGH	800	m ³ /h	620
			l/s	172
			CFM	365
	MED	700	m ³ /h	520
			l/s	144
			CFM	306
	LOW	600	m ³ /h	450
			l/s	125
			CFM	265
Outdoor unit	HIGH	780	m ³ /h	3200
			l/s	889
			CFM	1883
	LOW	400	m ³ /h	-
			l/s	-
			CFM	-

2-11-3. DUCT CONNECTION

■ MODELS : AU *12F, AU *12U, AU *14F, AU *14U, AU *18F, AU *18U

● OUTLET AIR

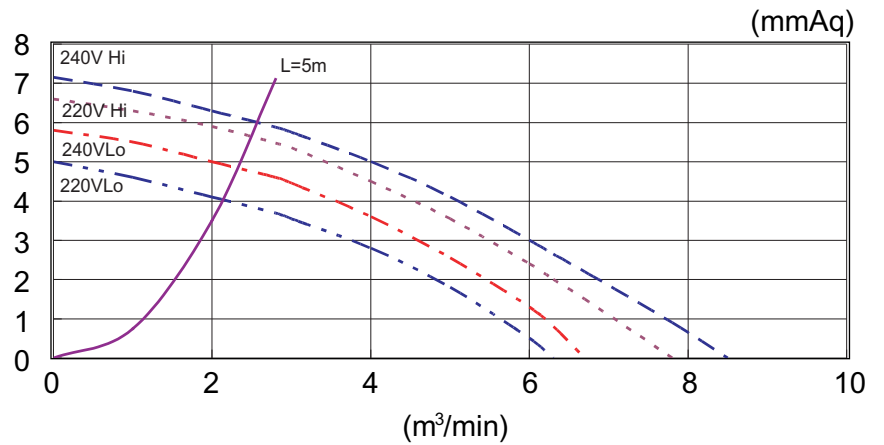
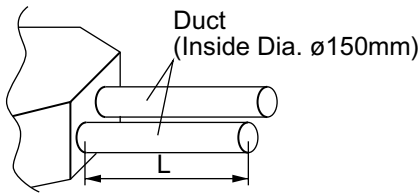
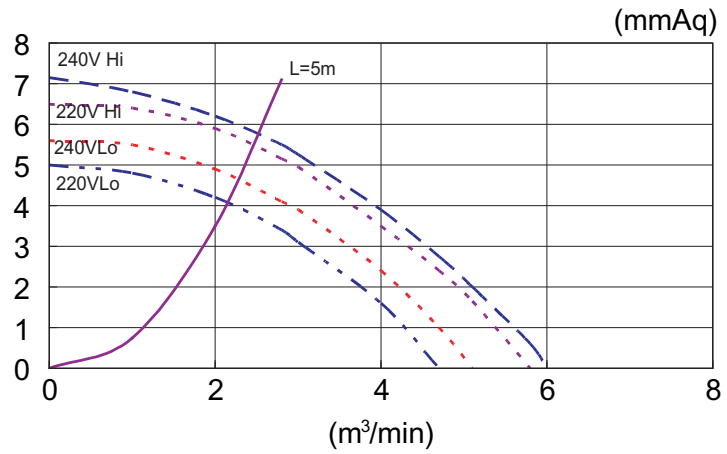
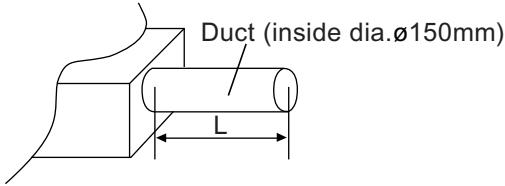

● FRESH AIR

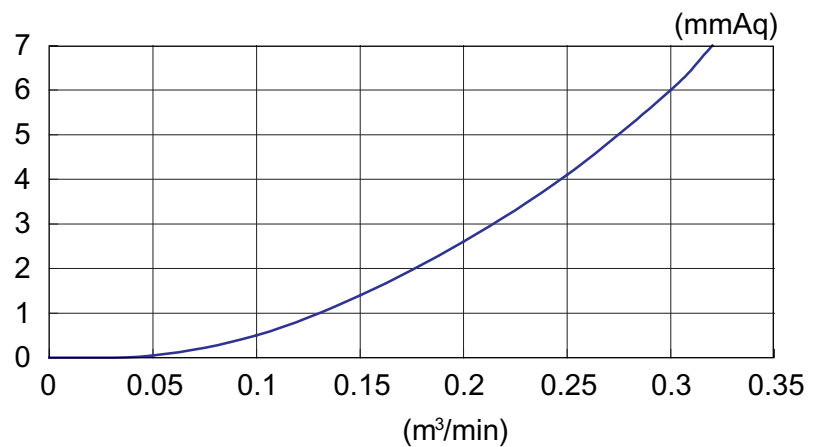
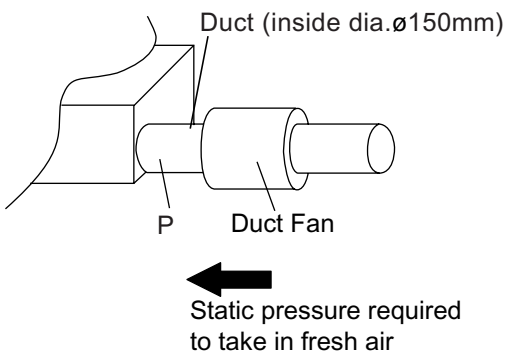

2-12. NOISE LEVEL CURVE

2-12-1. OUTDOOR UNIT

■ COOLING

● MODELS : AO*12F, AO*12U

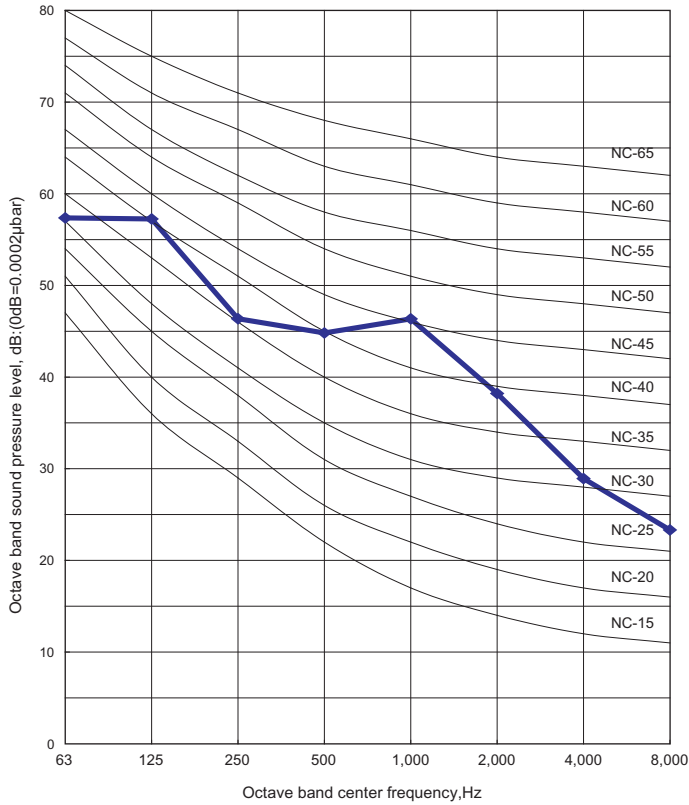

● MODELS : AO*14F, AO*14U

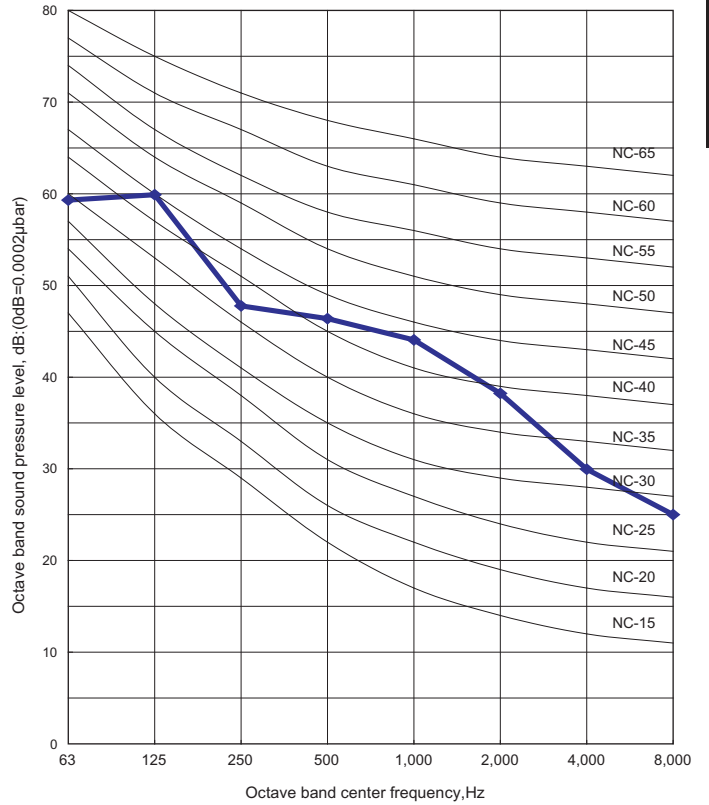

● MODELS : AO*18F, AO*18U

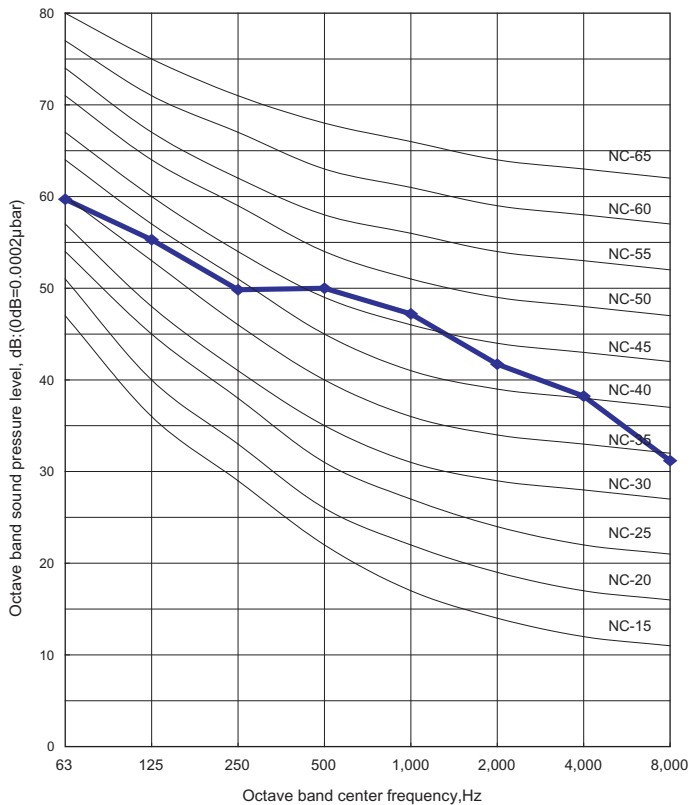

HEATING

MODEL : AO *12U

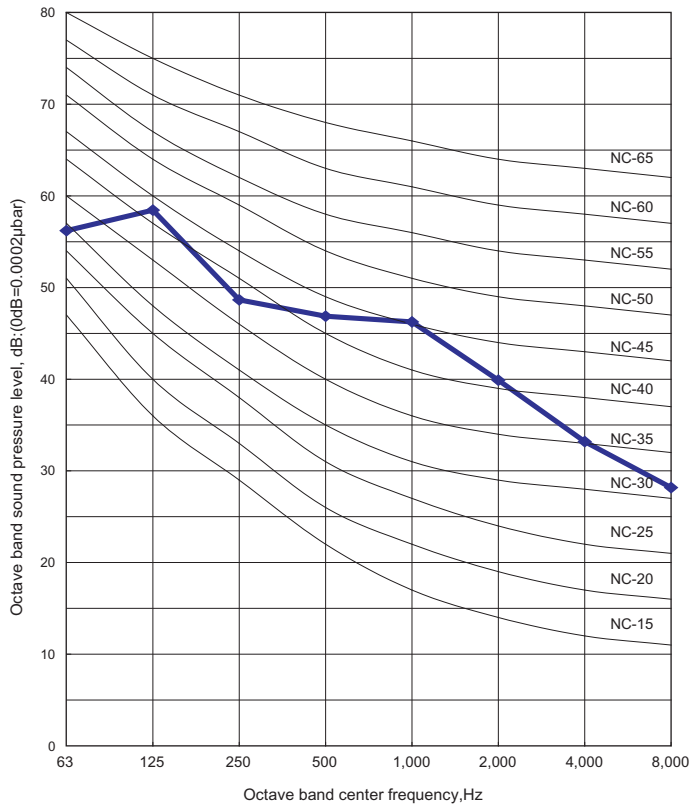

MODEL : AO *14U

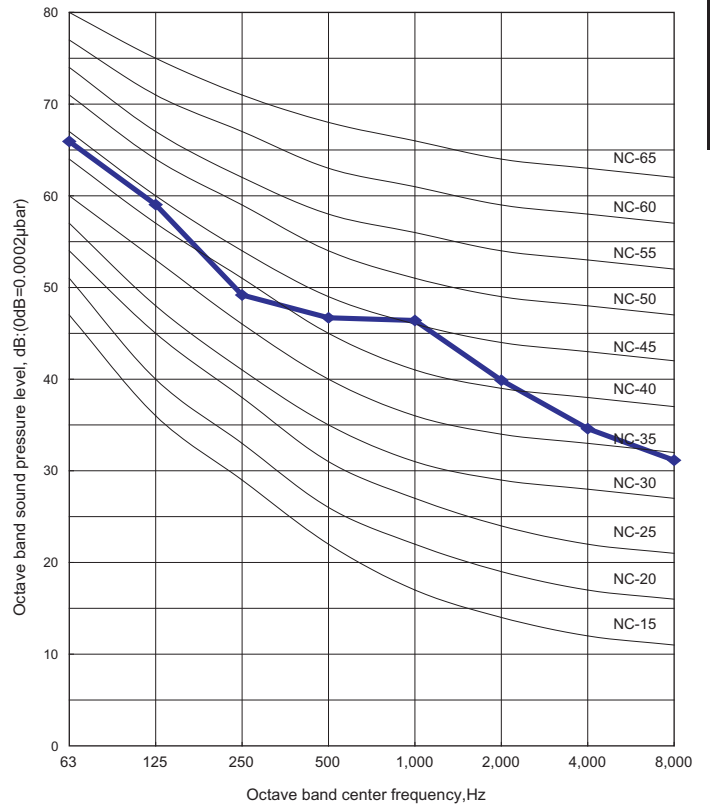

MODEL : AO *18U

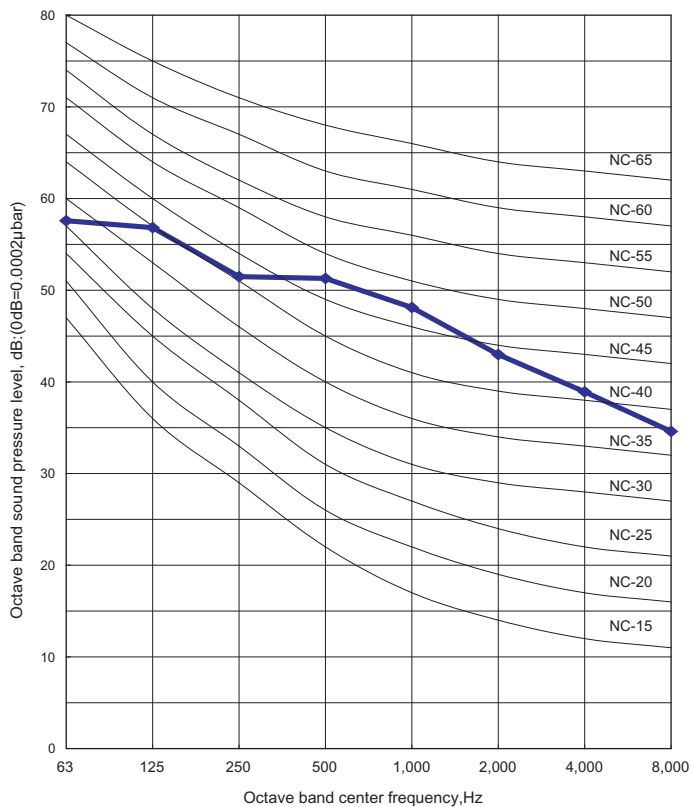

■ SOUND LEVEL CHECK POINT

CASSETTE TYPE
AU12-18

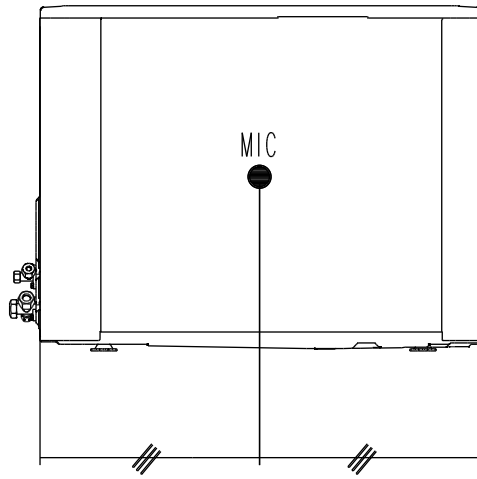
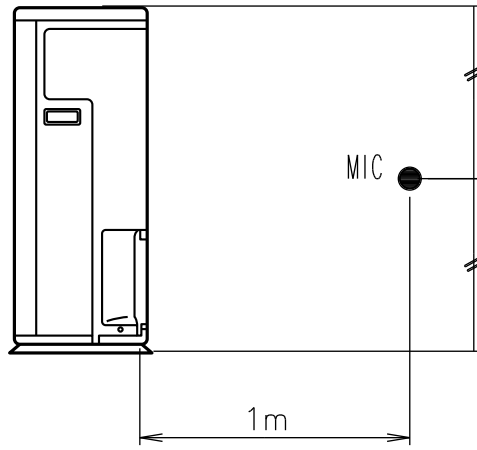

CASSETTE TYPE
AU12-18

2-12-2. INDOOR UNIT

■ COOLING

● MODELS : AU *12F, AU *12U
AU *14F, AU *14U

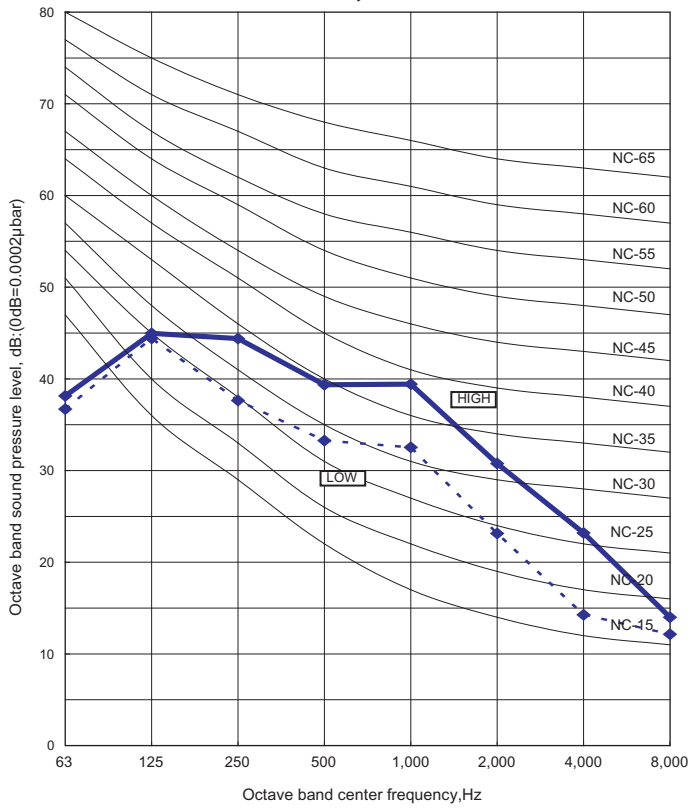

● MODELS : AU *18F, AU *18U

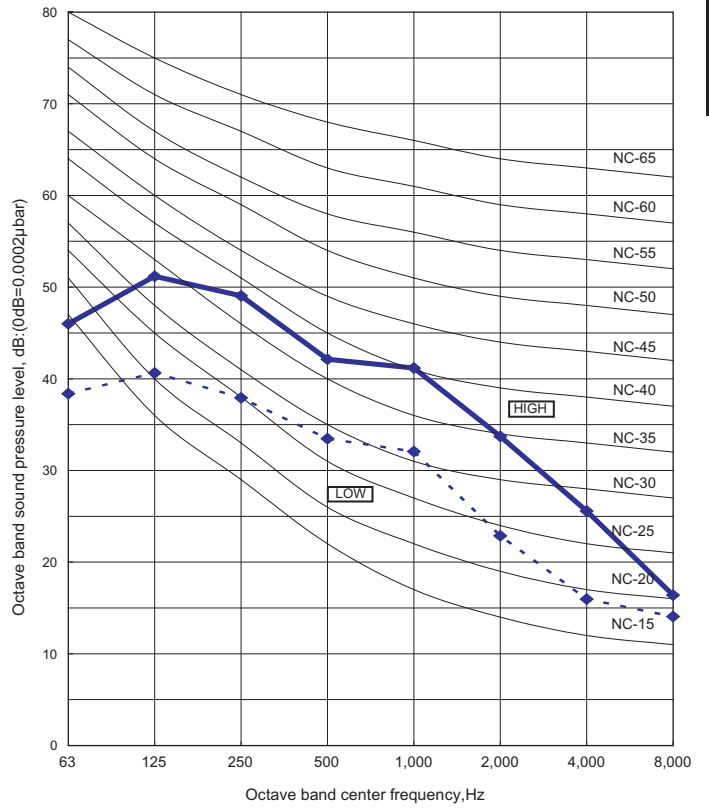

CASSETTE TYPE
AU12-18

CASSETTE TYPE
AU12-18

■ HEATING

● MODELS : AU *12U, AU *14U

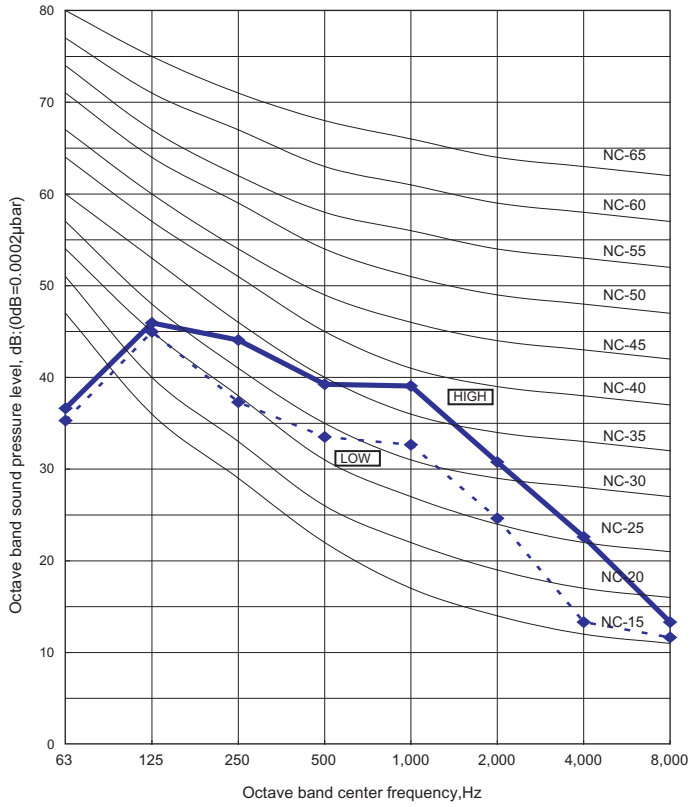

● MODEL : AU *18U

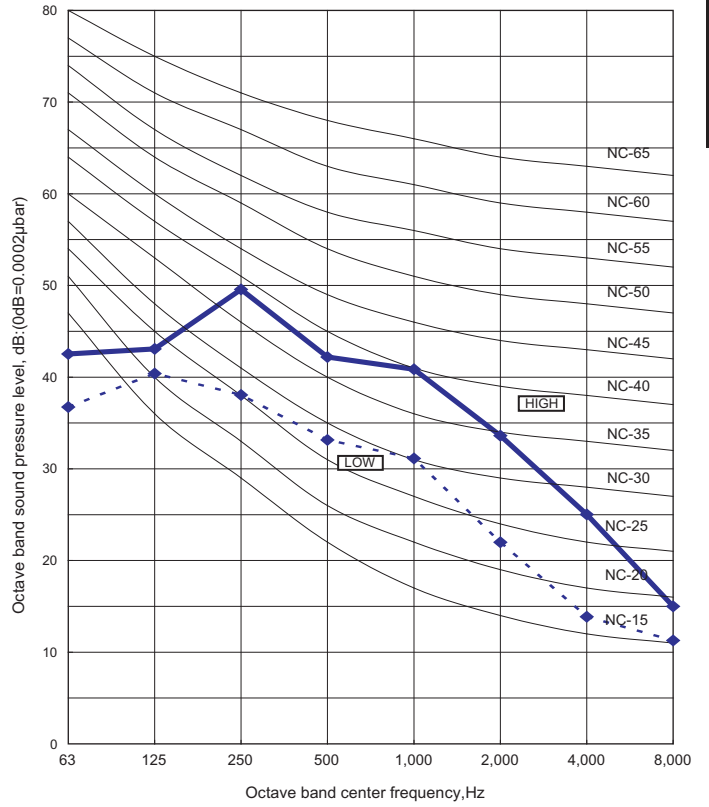

■ SOUND LEVEL CHECK POINT

CASSETTE TYPE
AU12-18

CASSETTE TYPE
AU12-18

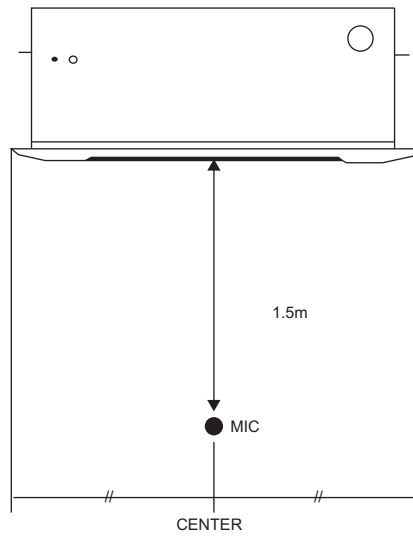
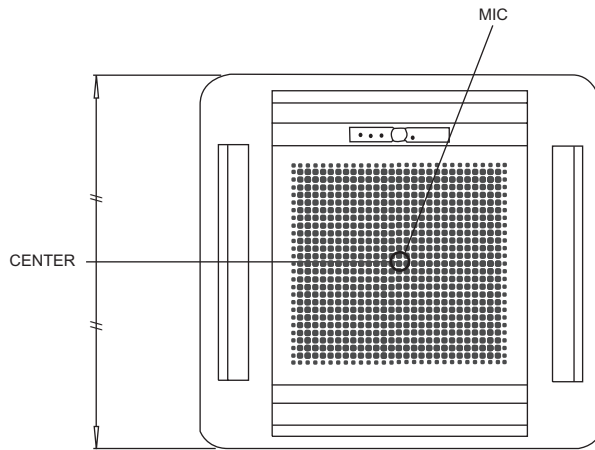

2-13. ELECTRIC CHARACTERISTICS

■ MODELS : AU*12F / AO*12F, AU*14F / AO*14F, AU*18F / AO*18F
 AU*12U / AO*12U, AU*14U / AO*14U, AU*18U / AO*18U

Model Name	Indoor unit		AU * 12F	AU * 14F	AU * 18F	AU * 12U		AU * 14U		AU * 18U	
	Outdoor unit		AO * 12F	AO * 14F	AO * 18F	AO * 12U		AO * 14U		AO * 18U	
Power Supply	Voltage	V	230 ~	230 ~	230 ~	230 ~		230 ~		230 ~	
		Hz	50	50	50	50		50		50	
Rated Value	Mode		Cooling	Cooling	Cooling	Cooling	Heating	Cooling	Heating	Cooling	Heating
	Current	A	5.5	6.3	8.5	5.5	5.4	6.3	6.3	8.2	9.2
	Input	kW	1.24	1.39	1.90	1.24	1.21	1.40	1.42	1.85	2.00
Max Operating Current		A	7.0	8.0	10.0	7.0	6.5	8.0	7.5	10.0	11.0
Starting Current		A	30	31	39	30	30	31	31	39	39
*1) Wiring Spec	Main Fuse (Circuit breaker) Current		A	15	15	20	15	15	15	20	20
	Power Cable	mm ²	2.0	2.0	2.5	2.0	2.0	2.0	2.5	2.5	2.5
	*2) Limited wiring length	m	32	27	24	32	32	26	26	25	25
Indoor Fan Motor	Input	kW	0.040	0.040	0.050	0.040	0.040	0.040	0.040	0.050	0.050
	Full Load Amp.	A	0.17	0.17	0.20	0.17	0.17	0.17	0.17	0.20	0.20
Outdoor Fan Motor	Input	kW	0.057	0.057	0.148	0.057	0.057	0.057	0.057	0.148	0.148
	Full Load Amp.	A	0.24	0.24	0.73	0.23	0.23	0.23	0.23	0.73	0.73

*1) Wiring Spec : Selected Sample (Selected based on Japan Electrotechnical Standard and Codes Committee E0005)

*2) Limited Wiring length : This is the wiring length in case voltage descent is less than 2%.

When the wiring length becomes long, please select the wiring of a more larger diameter.

2-14. SAFETY DEVICE

■ OUTDOOR UNIT

	PROTECTION FORM	AO * 12F	AO * 14F	AO * 18F	AO * 12U	AO * 14U	AO * 18U
FUSE (SIDE OF INDOOR UNIT)	-	5A 250V					
FAN MOTOR PROTECTOR	THERMAL PROTECTOR	140±5°C OFF	140±5°C OFF	150±5°C OFF	140±5°C OFF	140±5°C OFF	150±5°C OFF
COMPRESSOR	THERMAL PROTECTOR	OFF 150±5°C (23.5A/25°C) (9.6A/80°C) ON 69±11°C	OFF 160±5°C (25.5A/25°C) (10.7A/80°C) ON 69±11°C	OFF 150±5°C (30A/25°C) (13A/80°C) ON 69±11°C	OFF 150±5°C (23.5A/25°C) (9.6A/80°C) ON 69±11°C	OFF 160±5°C (25.5A/25°C) (10.7A/80°C) ON 69±11°C	OFF 150±5°C (30A/25°C) (13A/80°C) ON 69±11°C

■ INDOOR UNIT

	PROTECTION FORM	AU * 12F	AU * 14F	AU * 18F	AU * 12U	AU * 14U	AU * 18U
PCB FUSE	-	3.15A 250V					
FAN MOTOR PROTECTOR	THERMAL PROTECTOR	140±5°C OFF					

2-15. FUNCTION SETTING

2-15-1. INDOOR UNIT

CASSETTE TYPE
AU12-18

CASSETTE TYPE
AU12-18

INDOOR UNIT			
DIP SW	SW 1	1	Auto restart validity/invalidity
		2	Room temperature correct coefficient
		3	Room temperature correct coefficient
Jumper Wire		JM1	Forbidden
		JM2	Remote control unit single code
		JM3	Remote control unit single code

■ SWITCH POSITION

● Indoor unit control circuit board

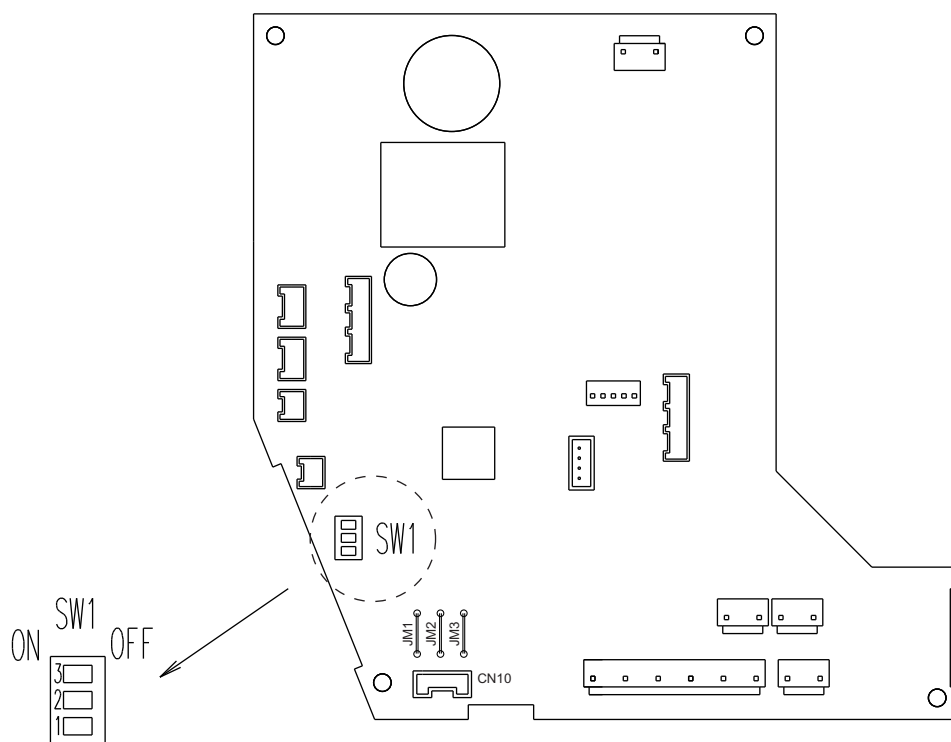

2-15-2. SWITCH FUNCTION (INDOOR UNIT)

■ DIP SWITCH SETTING

● SW1-1. Auto restart setting

Auto restart function can be selected by turning this switch ON/OFF.

AUTO RESTART SETTING

(◆ . . . Factory setting)

SW 1-1	SW state
OFF	Invalidity
ON	Validity

● SW1-2, 1-3. Room temperature correct coefficient of heating.

Decide the heating temperature correct coefficient vale of heating.

TEMPERATURE CORRECTION

(◆ . . . Factory setting)

SW 1-2	SW 1-3	SW state		
		heating	dry	cooling
OFF	OFF	+2 deg	-2 deg	-2 deg
ON	OFF	-2 deg	-2 deg	-2 deg
OFF	ON	0 deg	0 deg	0 deg
ON	ON	+4 deg	0 deg	0 deg

■ JUMPER WIRE SETTING

JM 1, 2, 3 setting

(◆ . . . Factory setting)

Jumper wire		Remote control unit signal code
JM2	JM3	
connect	connect	A
connect	Disconnect	B
Disconnect	connect	C
Disconnect	Disconnect	D

2-16. OPTIONAL PARTS

■ ADDITIONAL GRILLE UTG-AGDA-W

The additional grille hides the gap between the ceiling hole and the outlet grille.

Additional grille (optional parts)

