



**SPLIT TYPE
AIR CONDITIONER**

CASSETTE type (50Hz)

SERVICE MANUAL



Models

Indoor unit

Outdoor unit

AUG18FBAB

AOG18FNCKL

AUG18FBAB

AOG18FNCNL

AUG18UBAB

AOG18UNCKL

AUG18UBAB

AOG18UNCNL

CONTENTS

SPECIFICATIONS	1
OUTLINE AND DIMENSIONS	2
REFRIGERANT SYSTEM DIAGRAM	4
CIRCUIT DIAGRAM	5
INDOOR PCB CIRCUIT DIAGRAM	7
ERROR CONTENTS	9
DISASSEMBLY ILLUSTRATION	10
PARTS LIST	18

SPECIFICATIONS

TYPE	COOL	
INDOOR UNIT	AUG18FBAB	
OUTDOOR UNIT	AOG18FNCKL	AOG18FNCNL
COOLING CAPACITY	5.00 kW	

ELECTRICAL DATA

POWER SOURCE	230 V 50 Hz
RUNNING CURRENT	8.5 A
INPUT WATTS	1.90 kW
E.E.R.	2.63 kW/kW
MOISTURE REMOVAL	2.1 L/hr
AIR CIRCULATION-HIGH	620 m ³ /hr

FAN MOTOR

INDOOR UNIT	DISCRIMINATION	MFA-18GTT	
	HIGH-SPEED	800 r.p.m.	
	MED-SPEED	700 r.p.m.	
	LOW-SPEED	600 r.p.m.	
OUTDOOR UNIT	DISCRIMINATION	MFB-24JTBT	MFB-24JTS
	HIGH-SPEED	780 r.p.m.	
	LOW-SPEED	400 r.p.m.	

DIMENSIONS

INDOOR UNIT	H x W x D	235 x 580 x 580 +70 mm
OUTDOOR UNIT	H x W x D	650 x 830 x 320 mm
GRILLE	H x W x D	35 x 650 x 650 mm

WEIGHT

INDOOR UNIT	Net / Gross	18 kg / 23 kg
OUTDOOR UNIT	Net / Gross	47 kg / 51 kg
GRILLE	Net / Gross	2.2 kg / 4.3 kg

REFRIGERANT CHARGE (R410A)

COMPRESSOR TYPE		Hermetic type, Rotary
DISCRIMINATION		5KS225DAC
FULL CHARGE	Pipe Length	7.5 m
		10 m
		15 m
		20 m
ADDITIONAL CHARGE		20 g/m
MAXIMUM PIPE HEIGHT		8 m
MAXIMUM PIPE LENGTH		20 m

TYPE	COOL & HEAT	
INDOOR UNIT	AUG18UBAB	
OUTDOOR UNIT	AOG18UNCKL	AOG18UNCNL
COOLING CAPACITY	4.85 kW	
HEATING CAPACITY	5.40 kW	

ELECTRICAL DATA

POWER SOURCE		230 V 50 Hz
RUNNING CURRENT	COOLING	8.2 A
	HEATING	9.2 A
INPUT WATTS	COOLING	1.85 kW
	HEATING	2.00 kW
E.E.R.	COOLING	2.62 kW/kW
	HEATING	2.70 kW/kW
MOISTURE REMOVAL		2.1 L/hr
AIR CIRCULATION-HIGH		620 m ³ /hr

FAN MOTOR

INDOOR UNIT	DISCRIMINATION	MFA-18GTBT	
	HIGH-SPEED	800 r.p.m.	
	MED-SPEED	700 r.p.m.	
	LOW-SPEED	600 r.p.m.	
OUTDOOR UNIT	DISCRIMINATION	MFB-24JTBT	MFB-24JTBS
	HIGH-SPEED	780 r.p.m.	
	LOW-SPEED	400 r.p.m.	

DIMENSIONS

INDOOR UNIT	H x W x D	235 x 580 x 580 +70 mm
OUTDOOR UNIT	H x W x D	650 x 830 x 320 mm
GRILLE	H x W x D	35 x 650 x 650 mm

WEIGHT

INDOOR UNIT	Net / Gross	18 kg / 23 kg
OUTDOOR UNIT	Net / Gross	52 kg / 56 kg
GRILLE	Net / Gross	2.2 kg / 4.3 kg

REFRIGERANT CHARGE (R410A)

COMPRESSOR TYPE		Hermetic type, Rotary
DISCRIMINATION		5KS225DAC
FULL CHARGE	Pipe Length	7.5 m
		10 m
		15 m
		20 m
ADDITIONAL CHARGE		20 g/m
MAXIMUM PIPE HEIGHT		8 m
MAXIMUM PIPE LENGTH		20 m

OUTLINE AND DIMENSIONS

INDOOR UNIT

(unit : mm)

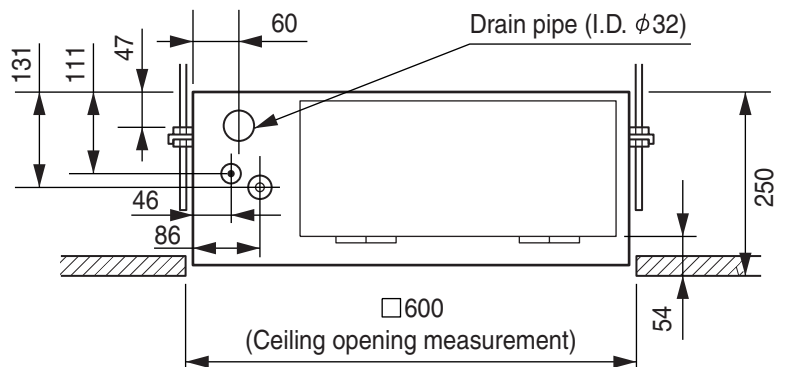
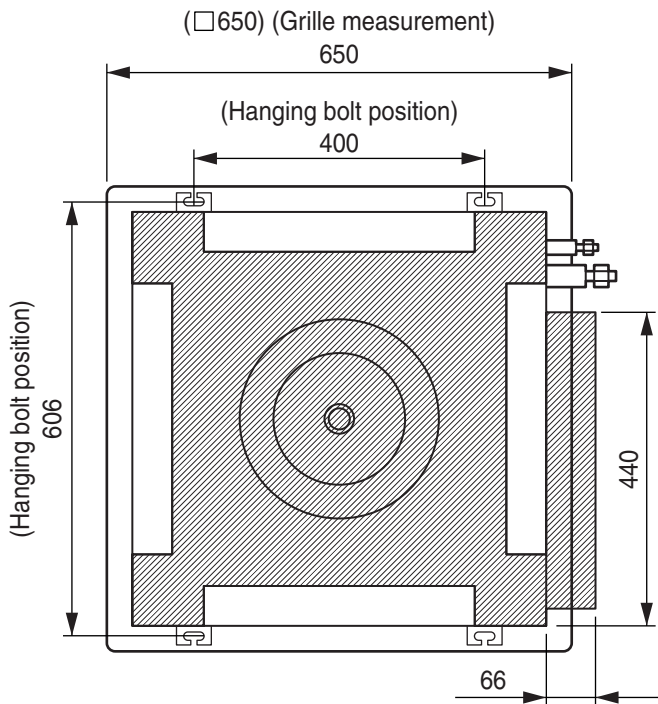
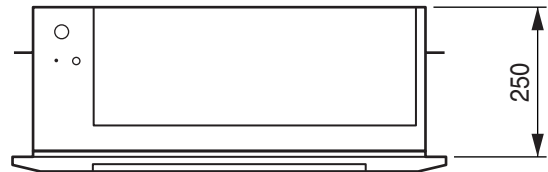
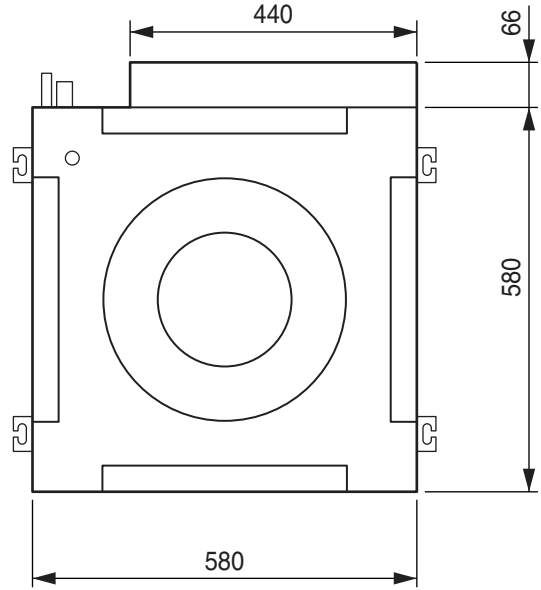
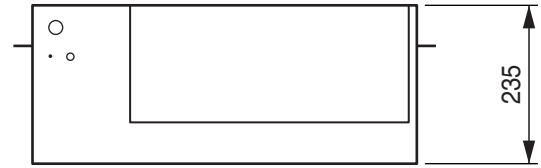
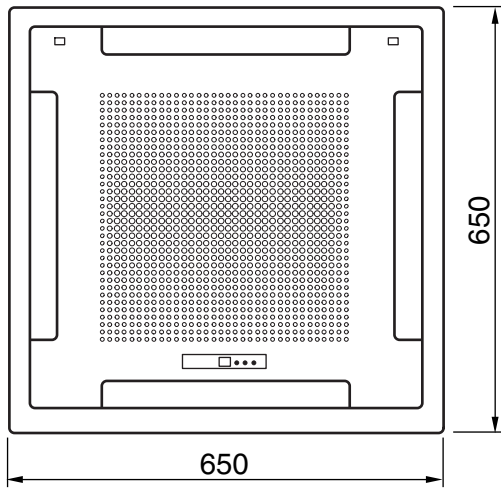

OUTDOOR UNIT

(unit : mm)

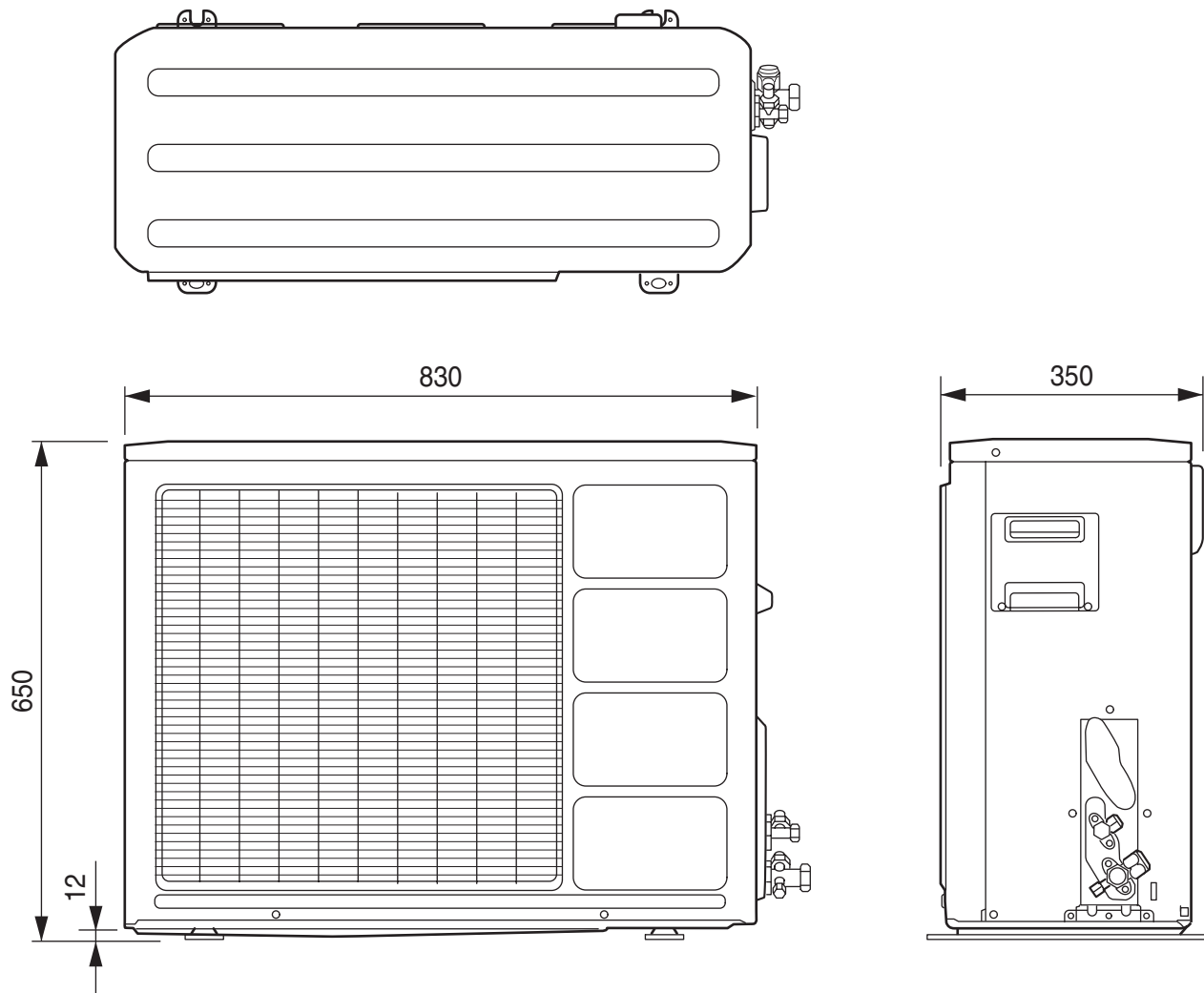

REFRIGERANT SYSTEM DIAGRAM

Models :

AUG18FBAB / AOG18FNCKL

AUG18FBAB / AOG18FNCNL

INDOOR UNIT

OUTDOOR UNIT

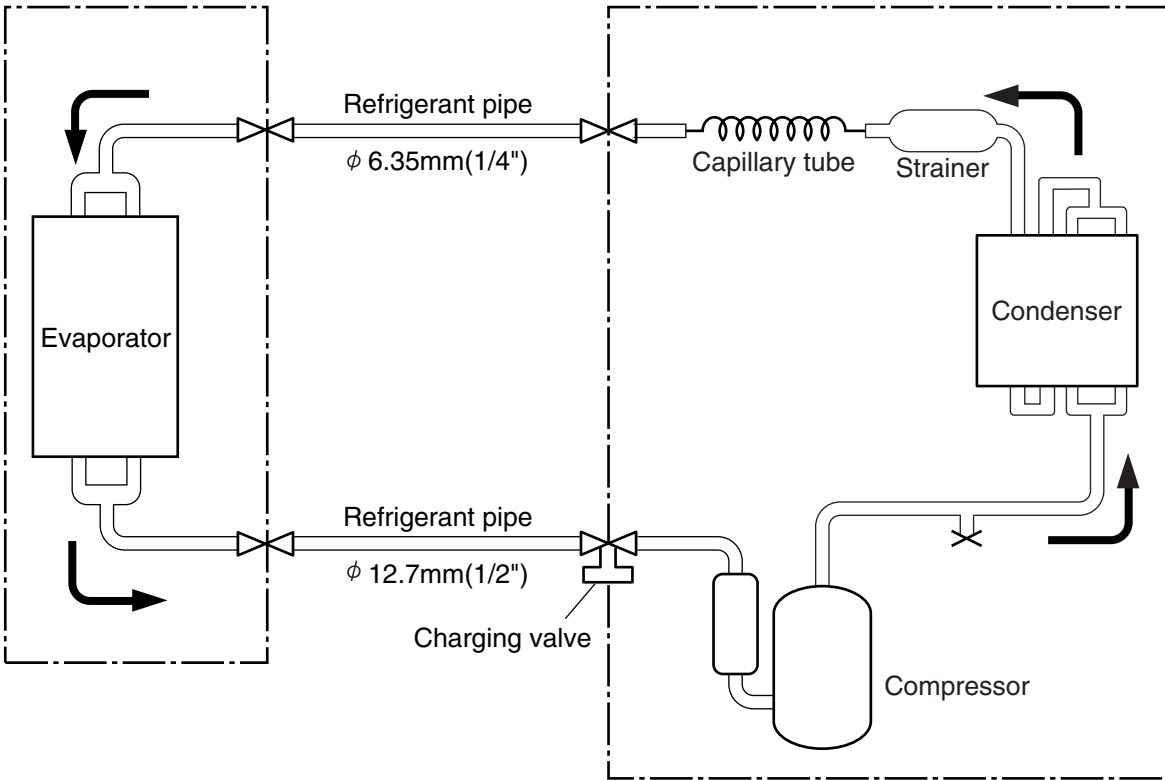

Models :

AUG18UBAB / AOG18UNCKL

AUG18UBAB / AOG18UNCNL

INDOOR UNIT

OUTDOOR UNIT

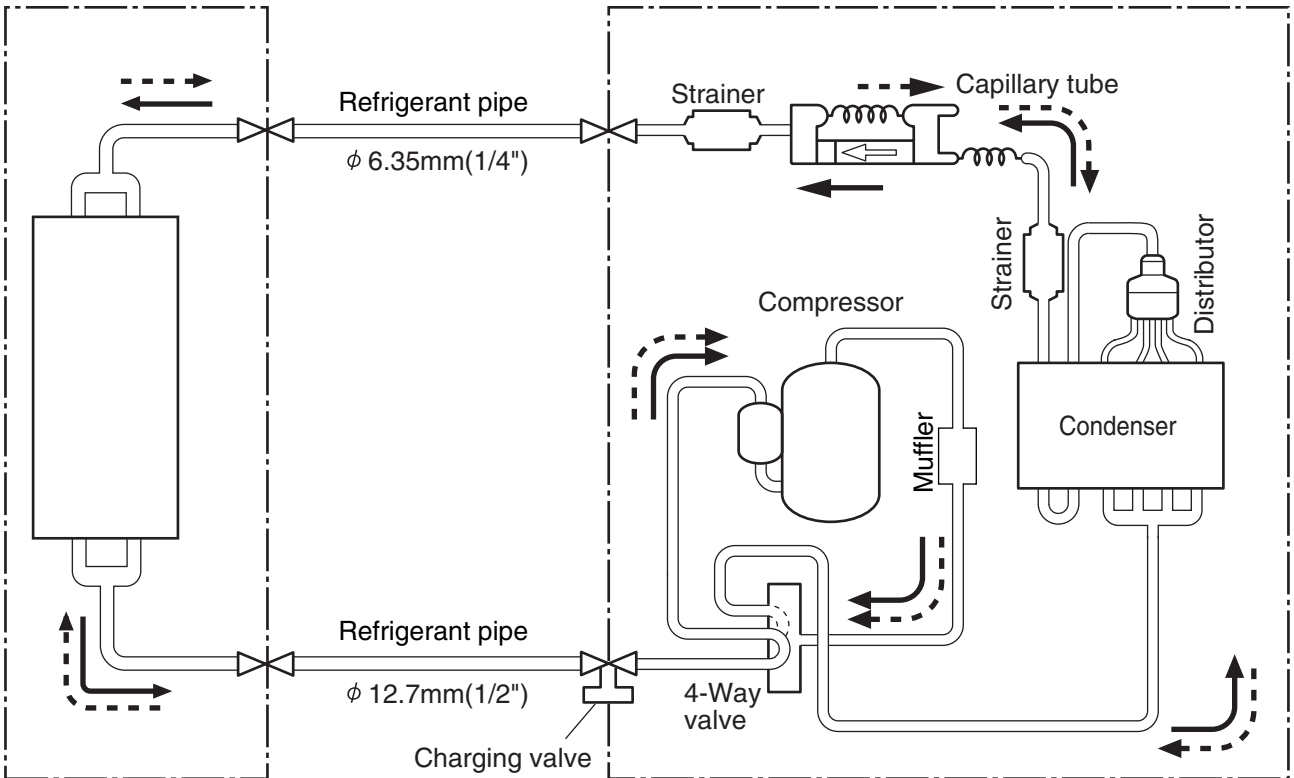

CIRCUIT DIAGRAM

Model : AUG18FBAB

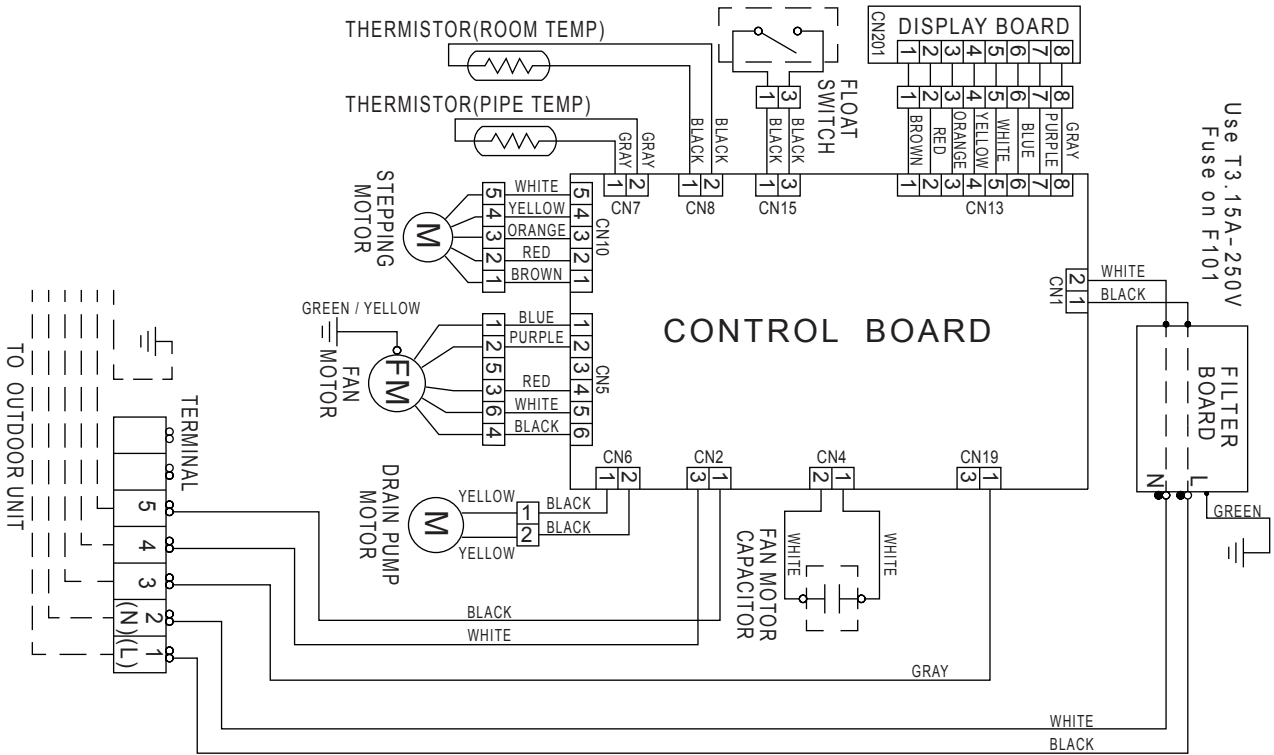

Models : AOG18FNCKL, AOG18FNCNL

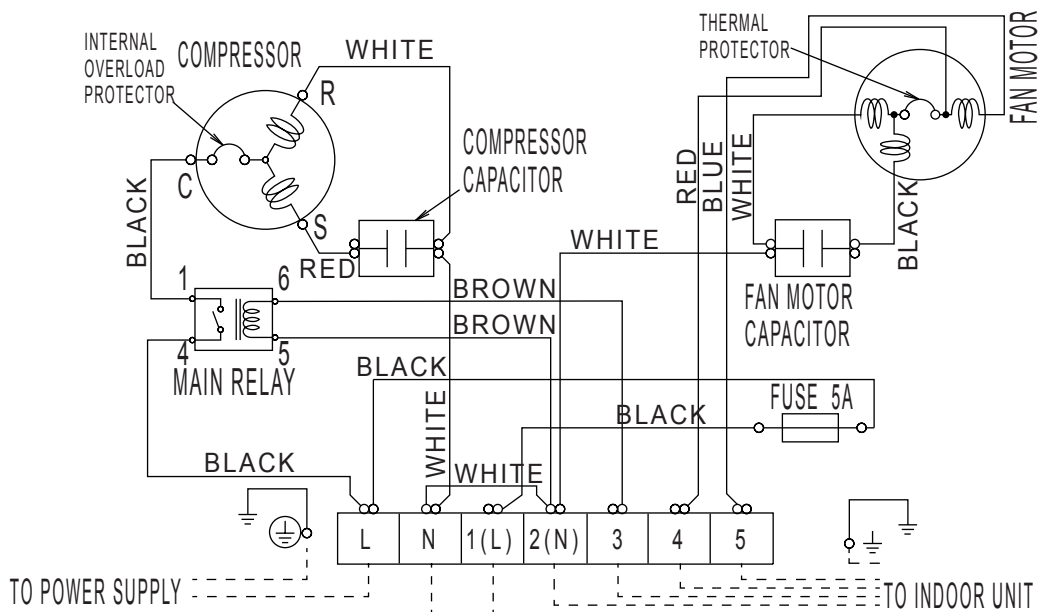

Model : AUG18UBAB

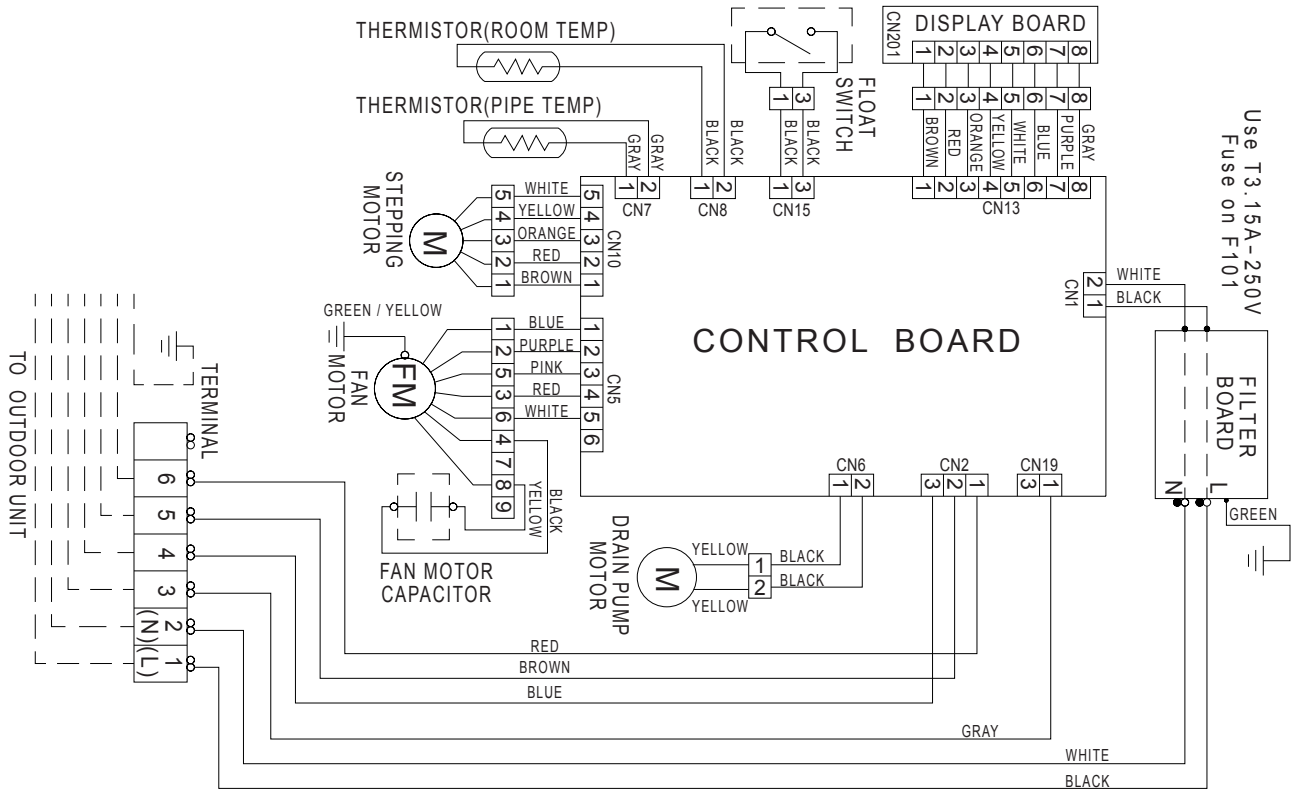

Models : AOG18UNCKL, AOG18UNCNL

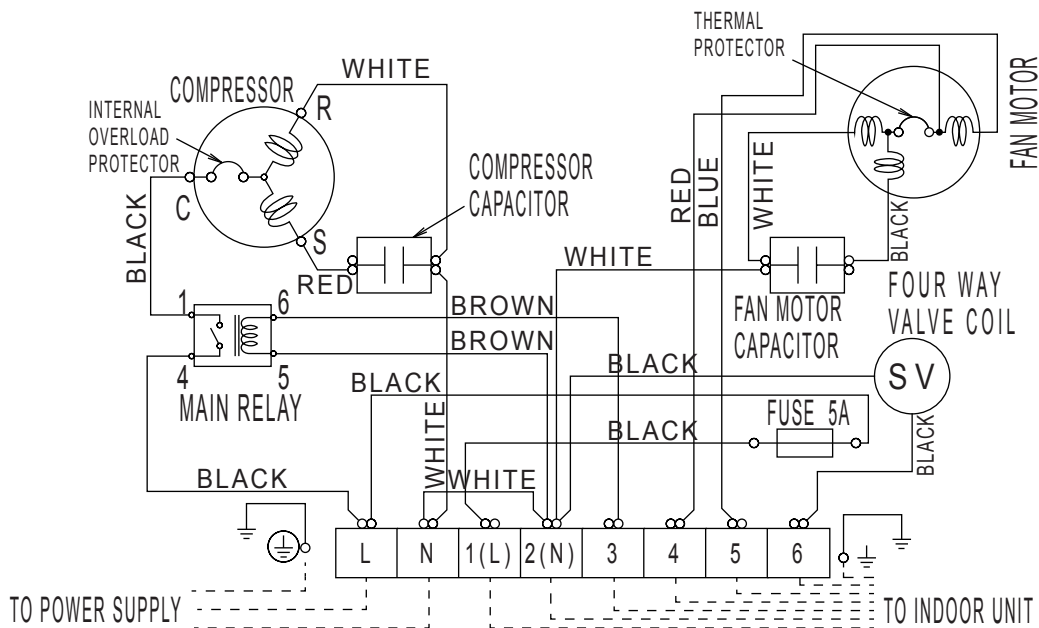

INDOOR PCB CIRCUIT DIAGRAM

Model : AUG18FBAB

Controller PCB Assy EZ-003SWSE-C

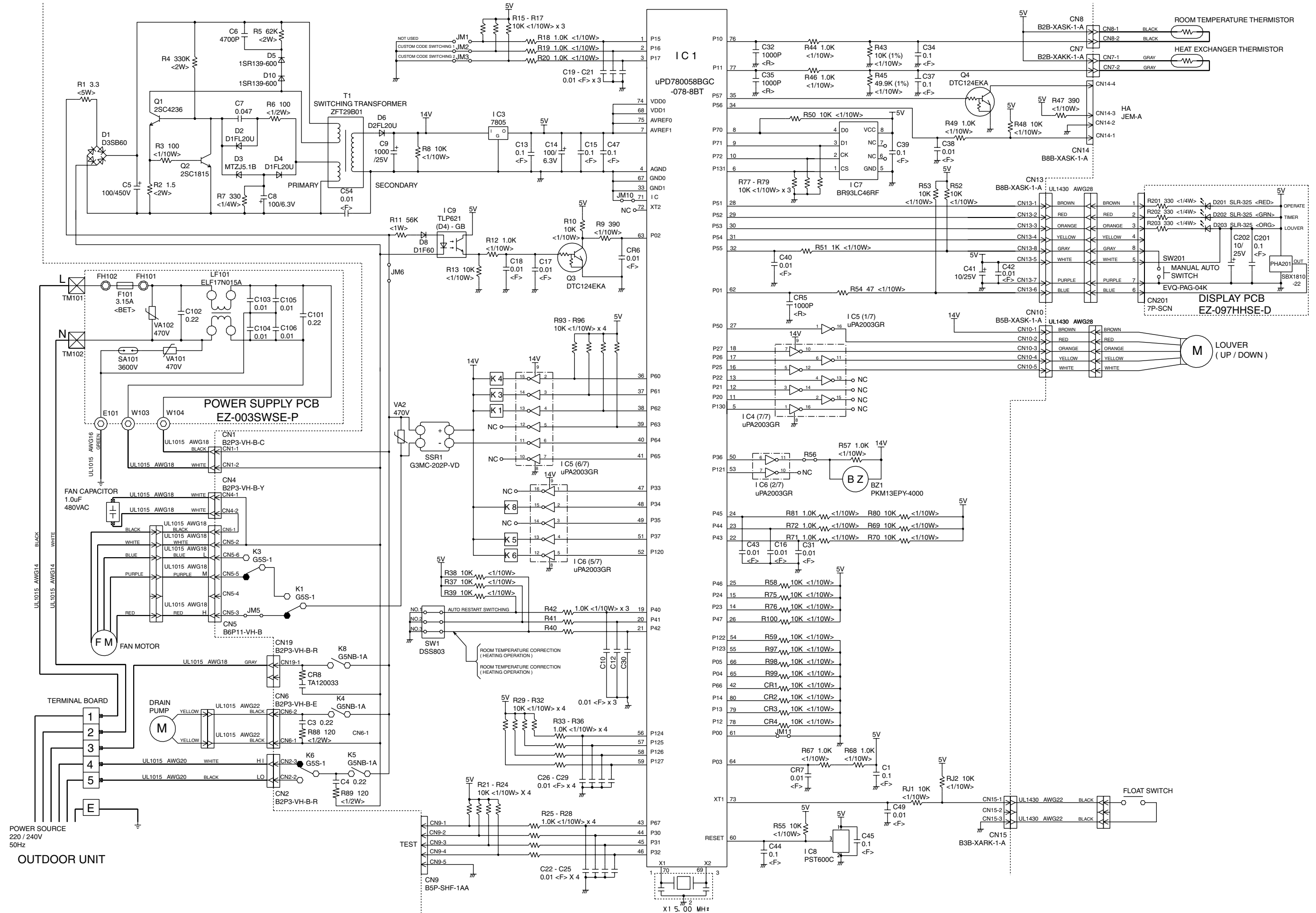

Controller PCB Assy
EZ-00306HSE-C

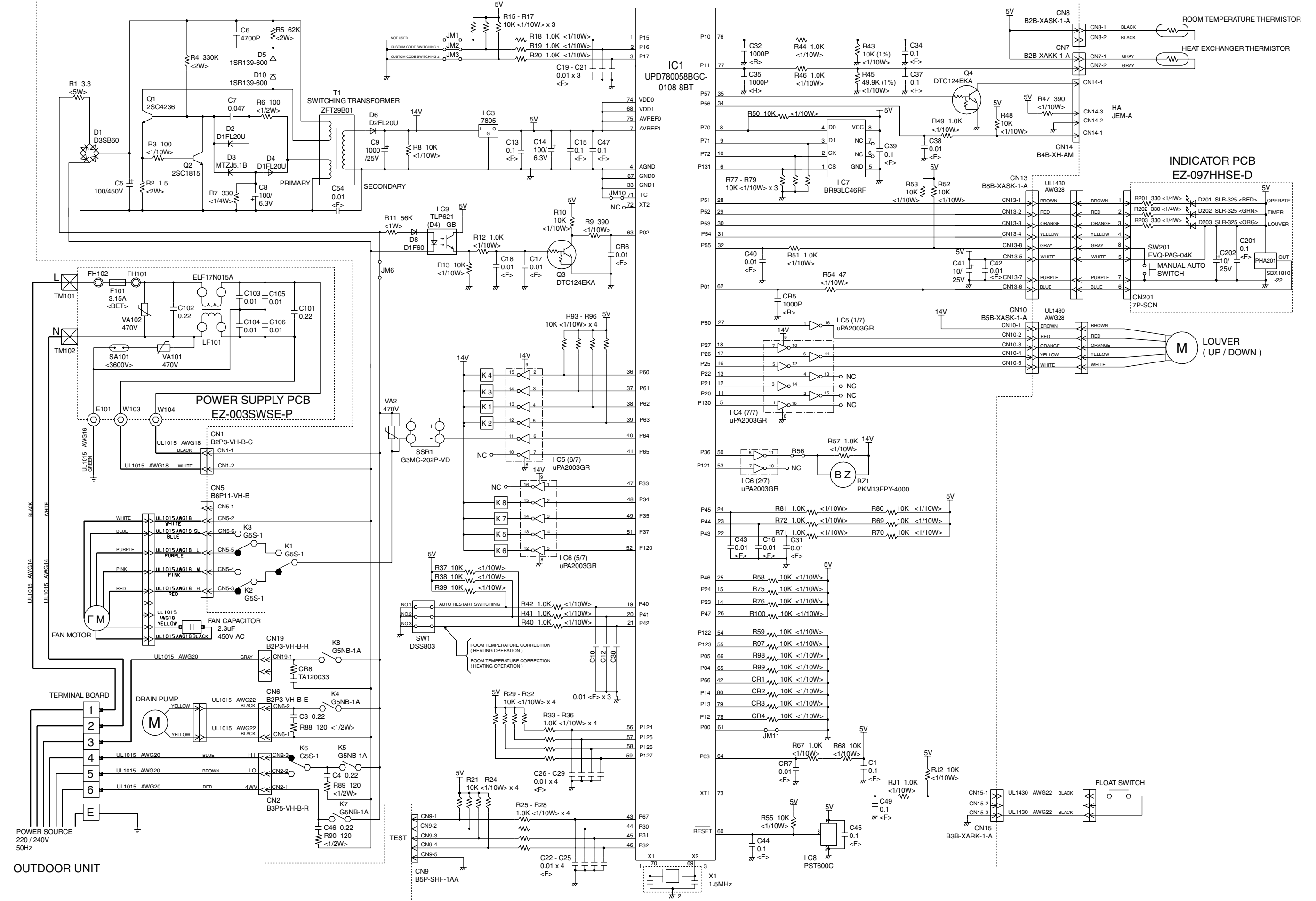

ERROR CONTENTS

Operation can be checked by lighting and flashing of the grille display section OPERATION and TIMER lamps.
Perform judgment in accordance with the following.

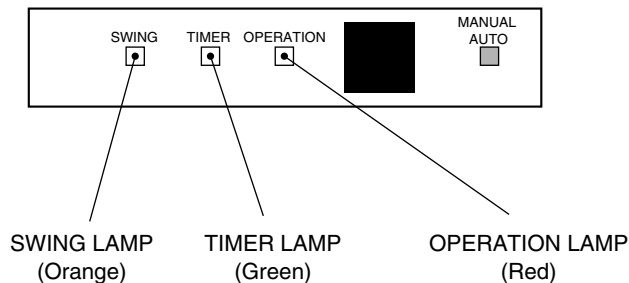

TEST RUNNING

When the air conditioner is run by pressing the remote control unit test run button, the OPERATION and TIMER lamps flash slowly at the same time.

ERROR

The OPERATION, TIMER, and SWING lamps operate as follows (Table 1) according to the error contents.

Table 1

Error display			Error contents
OPERATION lamp	TIMER lamp	SWING lamp	
Blinks	Blinks	Goes off	Model information abnormal (permanent type)
Pulses 4 times	Blinks	Goes off	Drain abnormal (permanent type)
Pulses 6 times	Blinks	Goes off	Indoor fan abnormal
Pulses 2 times	Blinks	Goes off	Room air temperature thermistor open circuit
		Blinks	Room air temperature thermistor short circuit
Pulses 3 times	Blinks	Goes off	Piping thermistor open circuit
		Blinks	Piping thermistor short circuit

CHECK ITEMS

1. INDOOR UNIT

- (1) Is operation of each button on the remote control unit normal?
- (2) Does each lamp light normally?
- (3) Do not air flow direction louvers operate normally?
- (4) Is the drain normal?
- (5) Is there any abnormal noise and vibration during operation?

2. OUTDOOR UNIT

- (1) Is there any abnormal noise and vibration during operation?
 - (2) Will noise, wind or drain water from the unit disturb the neighbors?
 - (3) Is there any gas leakage?
- Do not operate the air conditioner in the test running state for a long time.

DISASSEMBLY ILLUSTRATION

Models :
AUG18FBAB
AUG18UBAB

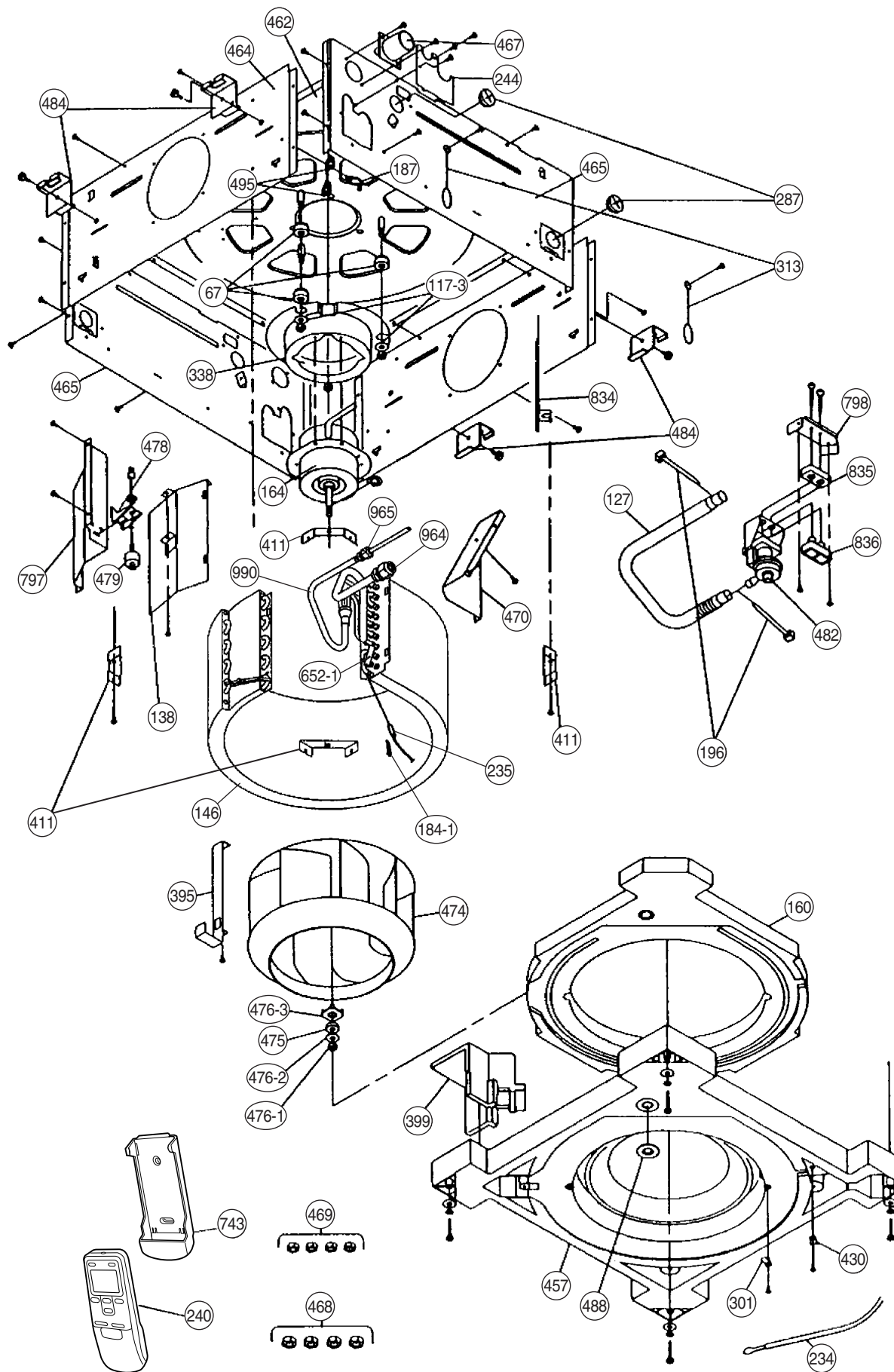

Models :
AUG18FBAB
AUG18UBAB

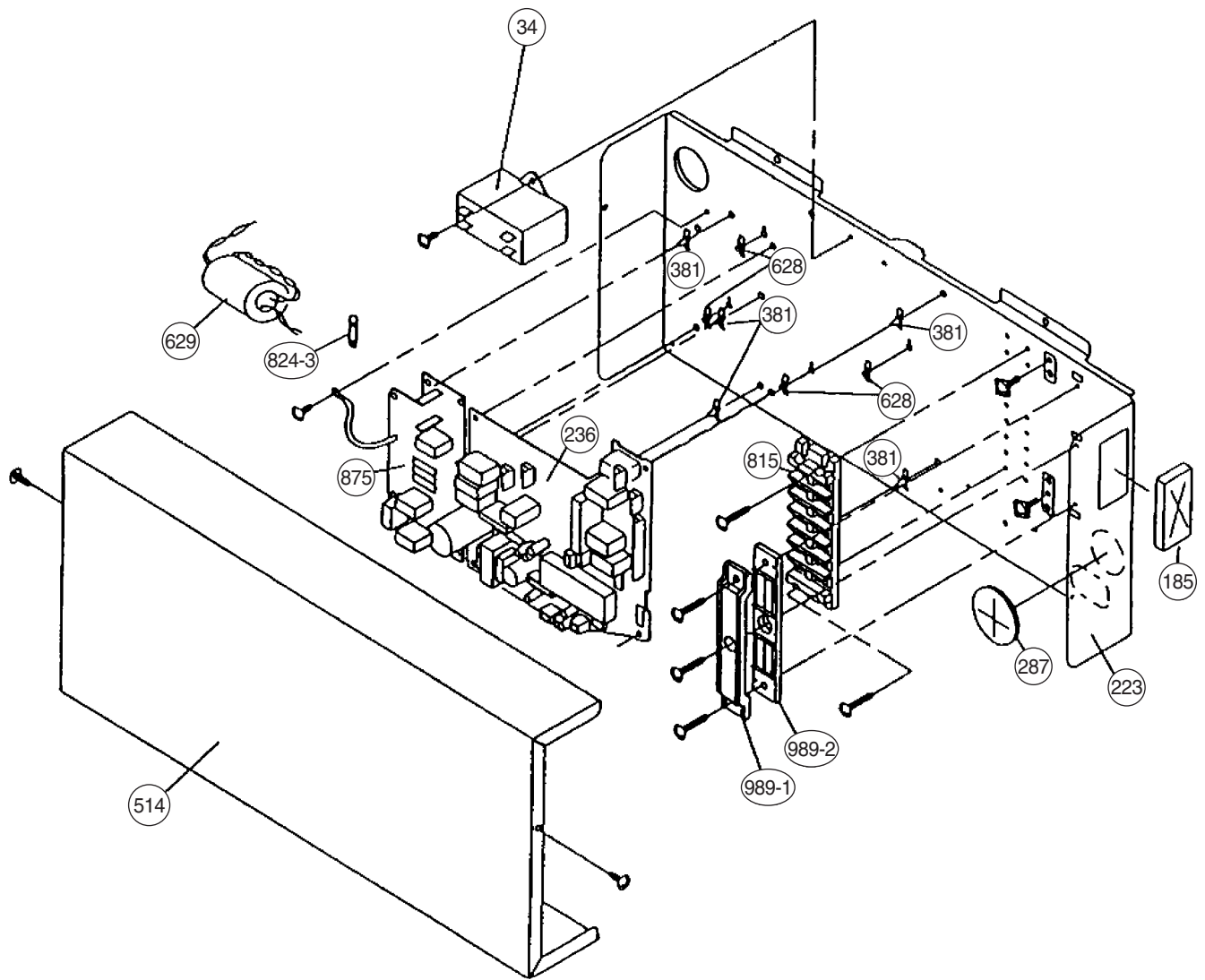

Model : UTG-UDGD-W

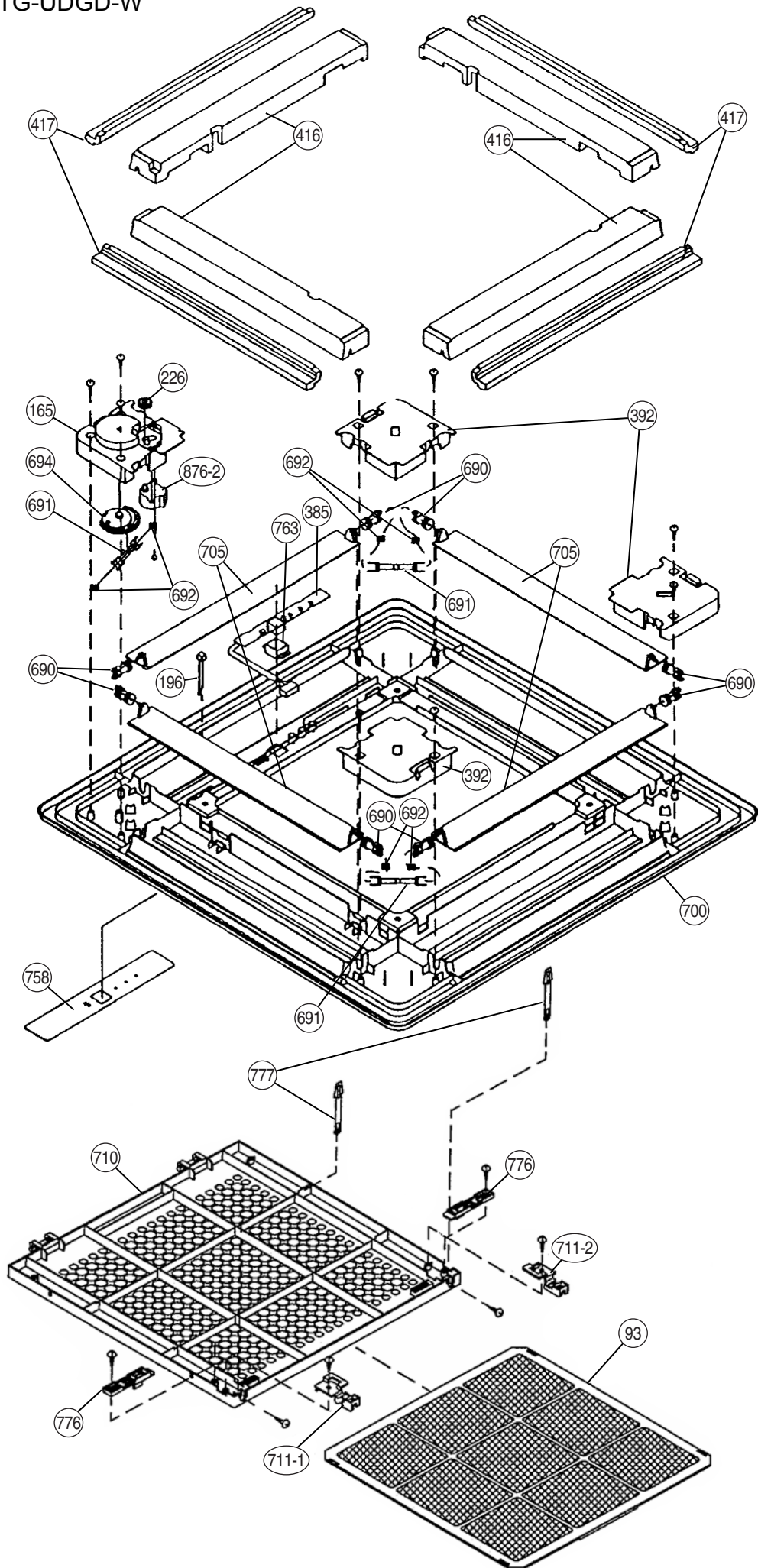

Models :
AOG18FNCKL
AOG18UNCKL
AOG18FNCNL
AOG18UNCNL

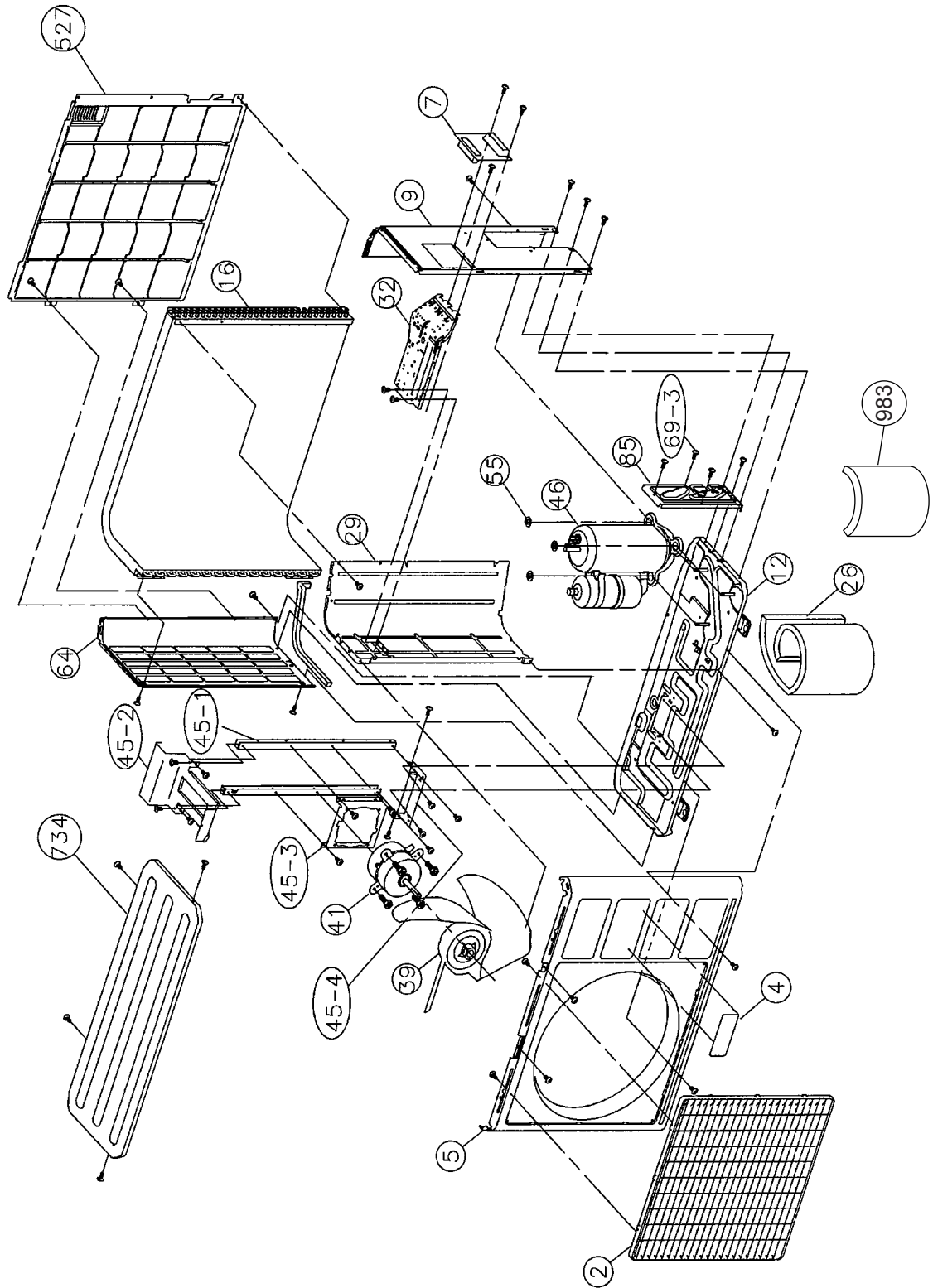

Models :
AOG18FNCKL
AOG18UNCKL
AOG18FNCNL
AOG18UNCNL

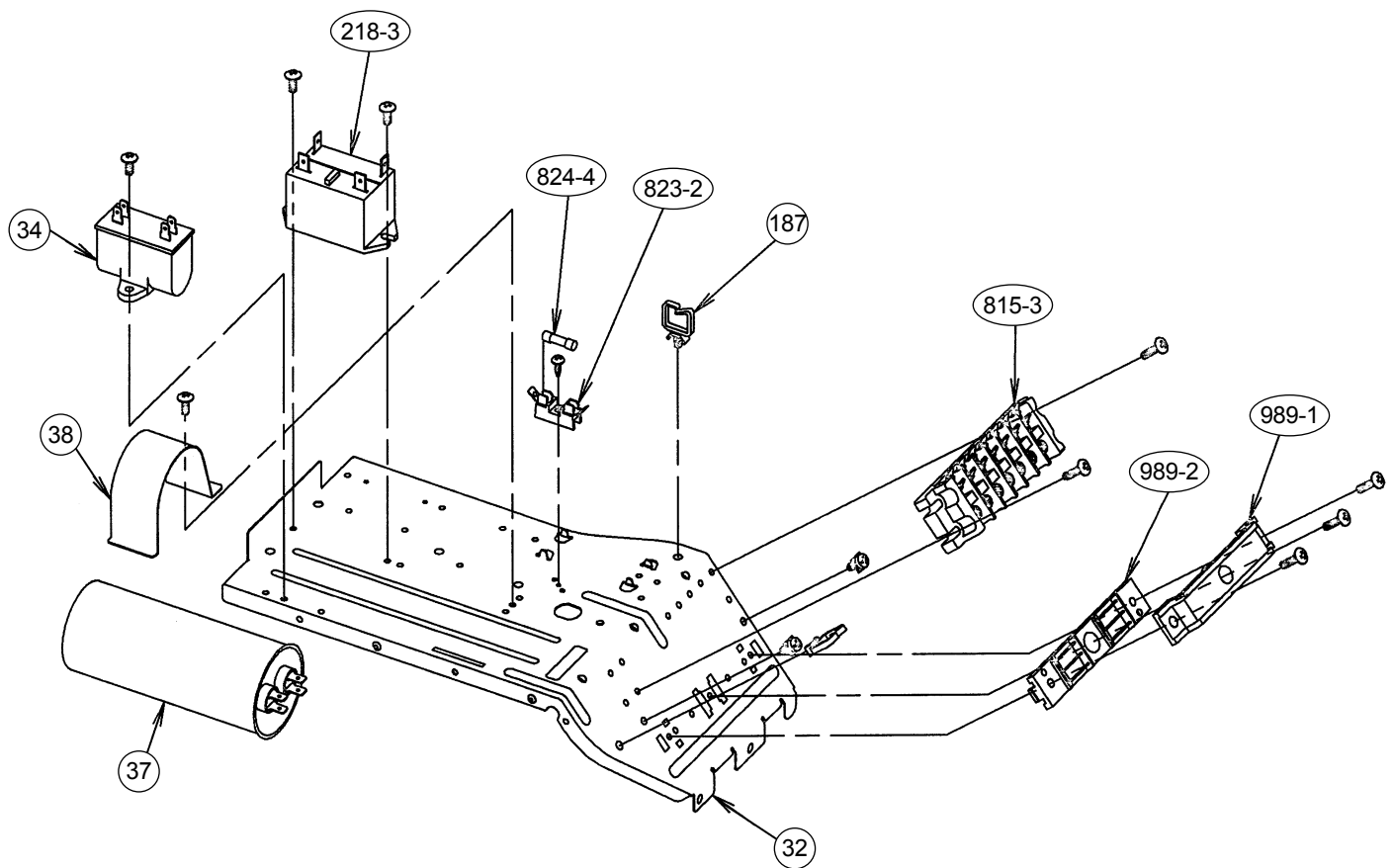

Models :
AOG18FNCKL
AOG18UNCKL
AOG18FNCNL
AOG18UNCNL

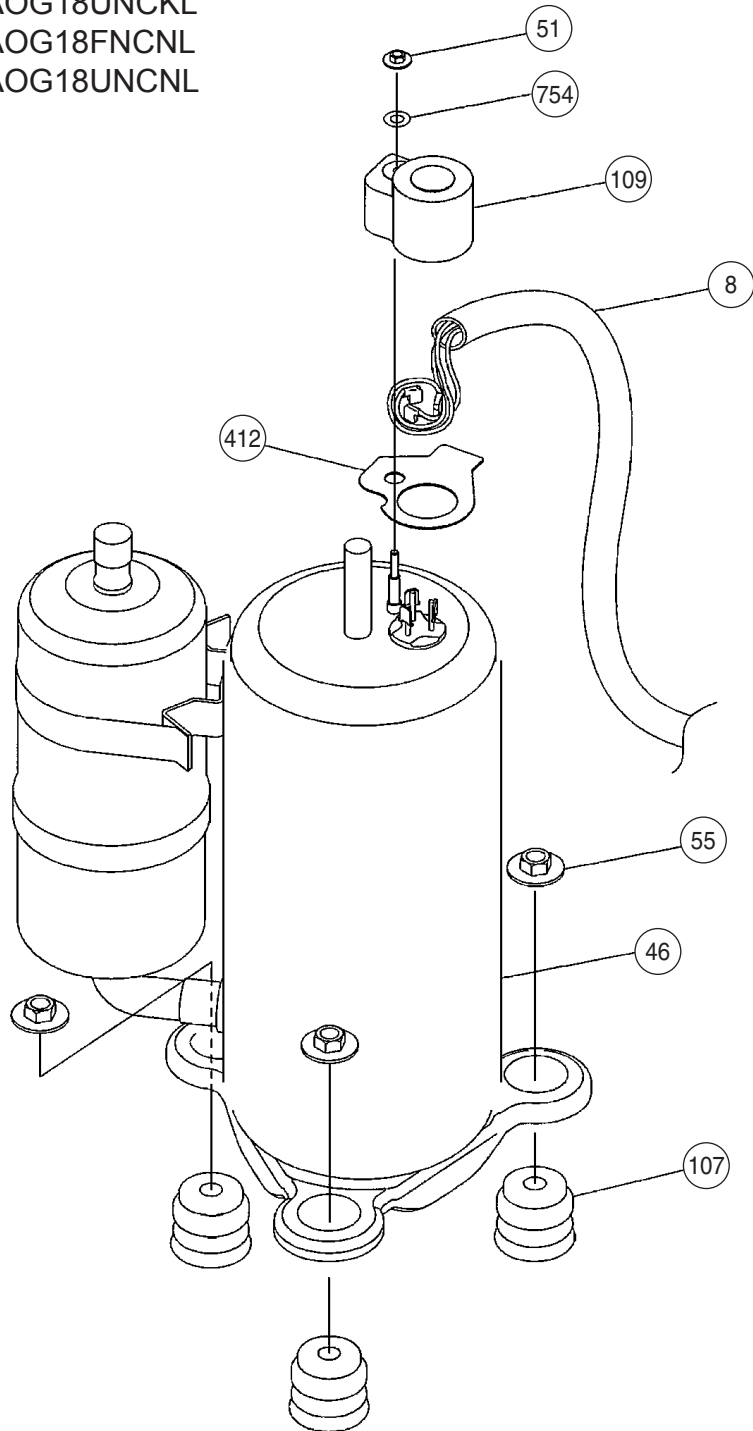

Models : AOG18FNCKL, AOG18FNCNL

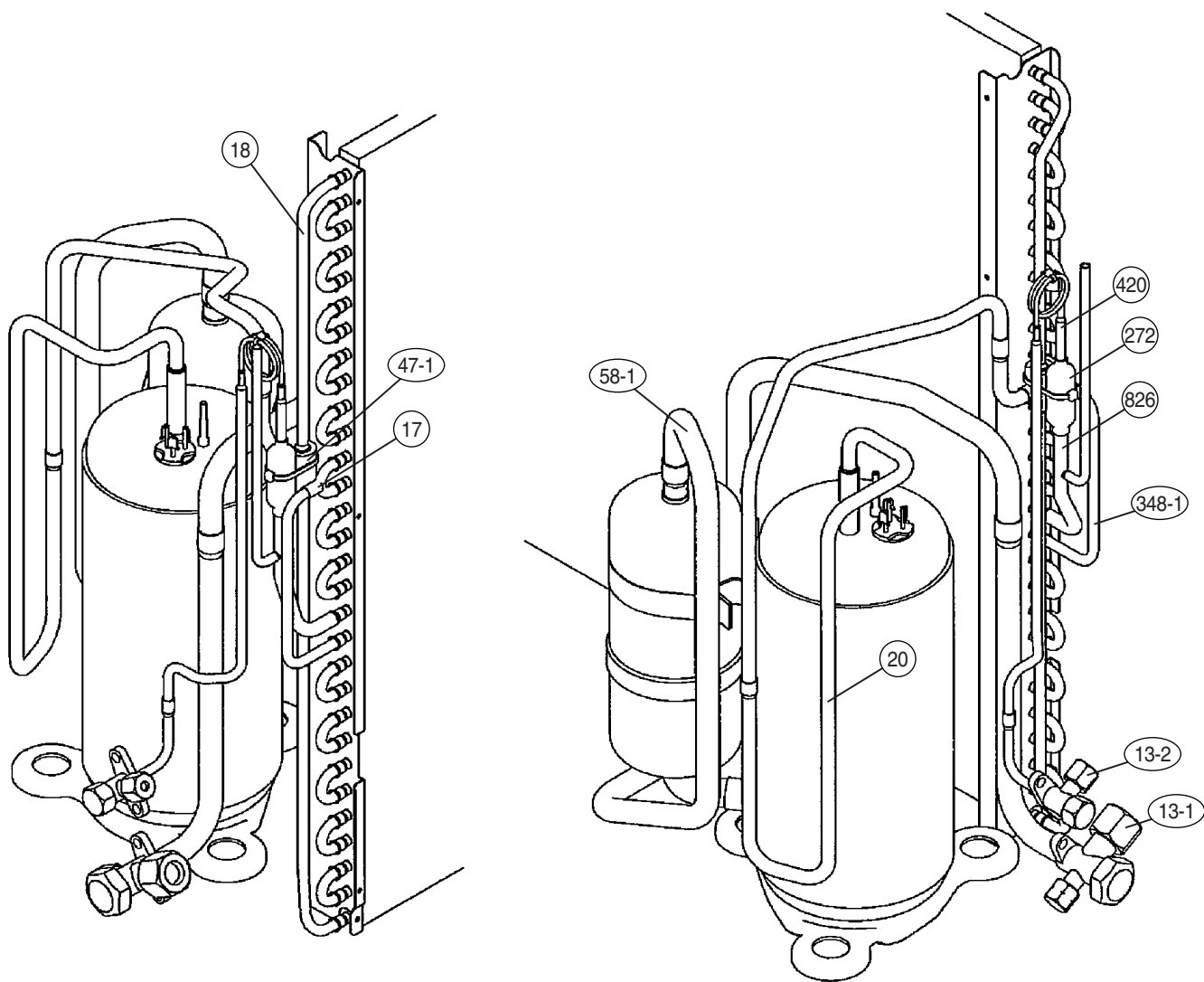

Models : AOG18UNCKL, AOG18UNCNL

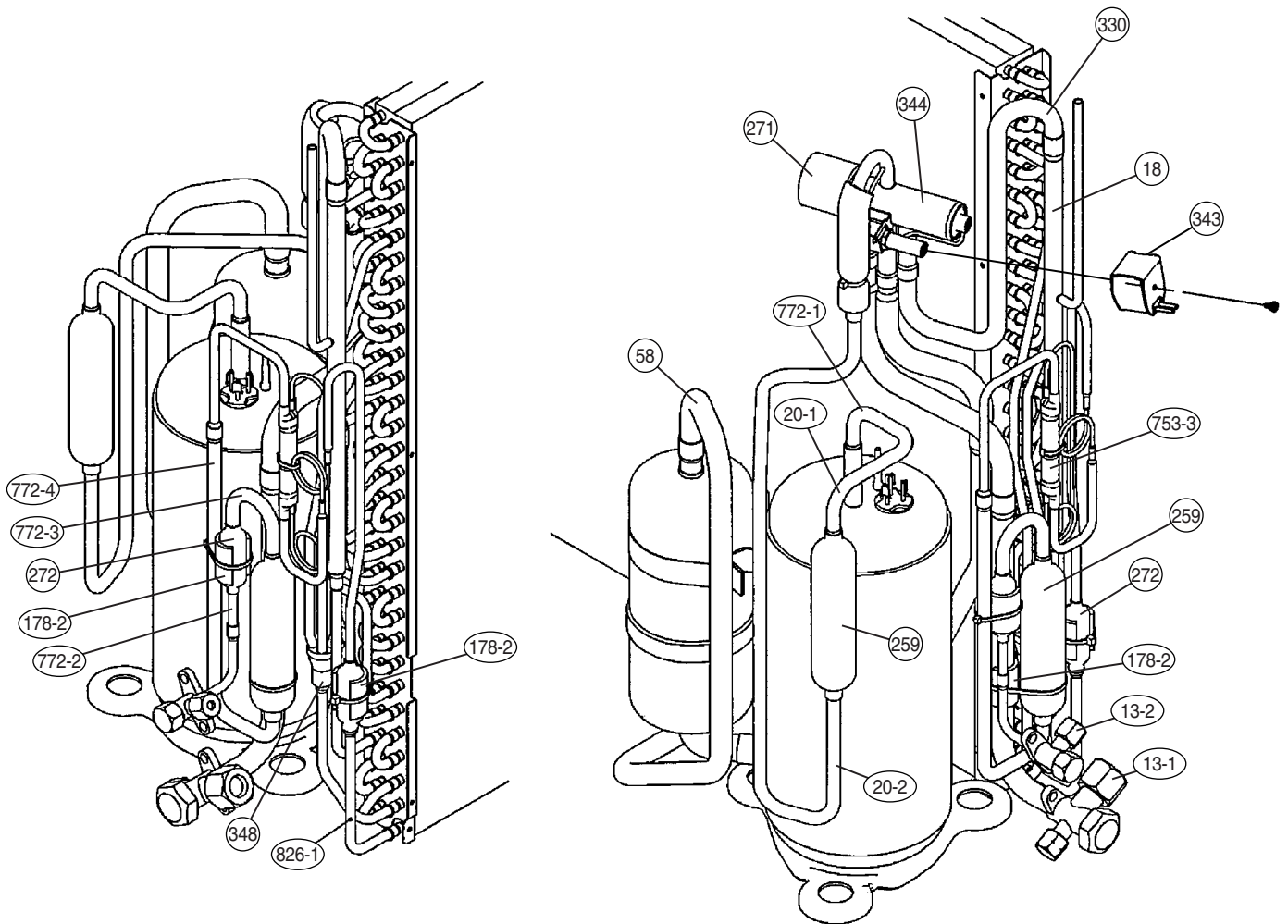

PARTS LIST

INDOOR UNIT

Ref. No.	Description	Part No.		Ord. Q'ty
		AUG18FBAB	AUG18UBAB	
34	Capacitor (Fan Motor)	9704305046	9703306044	
67	Rubber	9361279001	9361279001	
117-3	Special Washer M6	313306391007	313306391007	
127	Drain Hose	9359659013	9359659013	
138	Separate Wall-A	9359647003	9359647003	
146	Evaporator Assy-IN	9373214014	9373214014	
160	Drain Pan	9359651000	9359651000	
164	Fan Motor Assy-IN	9601040026	9601040057	
184-1	Thermo. Spring-A	313728262708	313728262708	
185	Rubber Bushing	313005066051	313005066051	
187	Clamp No. 1219	313361271706	313361271706	
196	Clamp SKB-150	313035356905	313035356905	
223	Control Box	9359661016	9359661016	
234	Thermistor Assy-Room	9703299032	9703299032	
235	Thermistor Assy-Pipe	9703297014	9703297014	
236	Controller PCB Assy	9704557490	9704557506	
240	Remote Control Unit	9371190044	9371190037	
244	Pipe Cover	9359646006	9359646006	
287	Cap (Power)	9352173011	9352173011	
301	Clamp NK-2N	313985355201	313985355201	
313	Hooking Wire	9359983002	9359983002	
338	Motor Fixture	9359656005	9359656005	
381	Locking Spacer	313209391506	313209391506	
395	Supporter (Eva.)	9373179016	9373179016	
399	Air Duct	9359660002	9359660002	
411	Supporter-A	9359655008	9359655008	
430	Clamp NK-7N	313095365602	313095365602	
457	Drain Pan Support	9359652007	9359652007	
462	Top Cover Plate	9359642015	9359642015	
464	Body-A	9359643005	9359643005	
465	Body-B	9359645009	9359645009	
467	Drain Port	313005415658	313005415658	
468	Special Nut-A (Large)	313005446653	313005446653	
469	Special Nut-B (Small)	313005446759	313005446759	
470	Separate Wall-B	9359648000	9359648000	
474	Turbo Fan	9359658009	9359658009	
475	Turbo Fan Rubber	9366013006	9366013006	
476-1	Special Nut M8	313005360755	313005360755	
476-2	Special Washer	301801185049	301801185049	
476-3	Special Washer	9359954002	9359954002	
478	Sensor M. Bracket	9359654001	9359654001	
479	Float Switch	313005416154	313005416154	
482	Pump Unit	9359974000	9359974000	
484	Hanger Metal	9359644002	9359644002	
488	Drain Pan Plug	9359653004	9359653004	
495	Clamp No. 2U46	9352715006	9352715006	
514	Control Box Cover	9359662006	9359662006	
628	Locking Spacer-B	313005446558	313005446558	
629	EMI Filter	0400197119	0400197119	
652-1	Therm. Holder Pipe	313806262805	313806262805	
743	Remote Control Holder Case	9305642014	9305642014	
797	Separate Wall-C	9359649007	9359649007	
798	Pump Hook Bracket	9359650003	9359650003	
815	Terminal-7P	9358660102	9358660102	
824-3	Fuse	0600222512	0600222512	
834	Wire Cover	9359878001	9359878001	
835	Cushion-A (For Pump)	9352211013	9352211013	
836	Cushion-B (For Pump)	9356084016	9356084016	
875	Filter PCB Assy	9704561169	9704561169	
964	Flare Nut-1/2	9373267010	9373267010	
965	Flare Nut-B	9351062019	9351062019	
989-1	Cord Clamp-A	9359822011	9359822011	
989-2	Cord Clamp-B	9359823018	9359823018	
990	Distributor Assy	9373034049	9373034049	
991	Coupling Pipe Assy	9373038030	9373038030	

GRILLE ASSY

Ref. No.	Description	Part No.	Ord. Q'ty
		UTG-UDGD-W	
93	Filter	9359632009	
165	Motor Cover	9359623014	
196	Clamp SKB-150	313035356905	
226	Motor Gear	9359629009	
385	Indicator PCB Assy	9702224011	
392	Cover-A	9359622017	
416	Insulation (Panel)-A	9359620006	
417	Insulation (Panel)-B	9359621003	
690	Joint-A	9359626008	
691	Joint-B	9359627005	
692	Joint Shaft	9359625001	
694	Cam Gear	9359628002	
700	Panel	9359619017	
705	Louver	9359624011	
710	Intake Grille	9370126006	
711-1	Filter Clamp-A	9359634003	
711-2	Filter Clamp-B	9359635000	
758	Decoration Plate-A	9360039026	
763	Receiver Cover	9359630005	
776	Grille Stopper	9359633013	
777	Grille Hook	9359761006	
876-2	Step Motor-V	9360307019	

OUTDOOR UNIT







Ref. No.	Description	Part No.		Ord. Q'ty
		AOG18FNCKL	AOG18UNCKL	
2	Fan Guard	9371187013	9371187013	
4	Emblem-Rear	9372171011	9372171011	
5	Front Panel	9371924014	9371924014	
7	Connector Cover (Cabinet)	9366398004	9366398004	
8	Wire Assy (Comp)	9372334010	9372334010	
9	Side Panel R	9371927015	9371927015	
12	Base Assy	9371920054	9371920054	
13-1	3-Way Valve Assy	9372205112	9372205112	
13-2	2-Way Valve Assy	9372204016	9372204016	
16	Condenser Assy	9372181041	9372181034	
26	Compressor Cover A	9372327012	9372327012	
29	Separate Wall	9371933016	9371933016	
32	Control Box	9371935010	9371935010	
34	Capacitor, Plastic	9900270049	9900270049	
37	Running Capacitor	9703107122	9703107122	
38	Capacitor Clamp Metal	9351770013	9351770013	
39	Propeller Fan Assy	9366378013	9366378013	
41	Motor Induct	9601671015	9601671015	
45-1	Motor Bracket	9371929019	9371929019	
45-2	Motor Bracket-Top	9371931012	9371931012	
45-3	Motor Bracket Center	9371930015	9371930015	
45-4	Motor Bracket Bottom	9371932019	9371932019	
46	Compressor Assy	9372558027	9372558027	
47-1	Rubber (Discharge pipe)	313194159807	-----	
51	Special Nut M5	9300301015	9300301015	
55	Special Nut M8	9355091008	9355091008	
64	Side Panel L	9371926018	9371926018	
69-3	Bolt, Hex. Socket	0700145148	0700145148	
85	Valve Plate	9371928012	9371928012	
107	Rubber Seat-A	9351049010	9351049010	
109	Terminal Cover (Comp)	9371511016	9371511016	
187	Clip (Cable)	9352715006	9352715006	
218-3	Relay	9900074012	9900074012	
259	Muffler	-----	9372369012	
271	4-Way Valve Rubber	-----	313728251908	
272	Strainer	9369287008	9369287008	
343	Solenoid	-----	9900165017	
344	4-Way Valve	-----	9970036019	
412	Cover Gasket (Comp.)	9371512013	9371512013	
527	Protectiive Net	9371934013	9371934013	
734	Top Panel Sub Assy	9372304013	9372304013	
735-3	Capillary Assy	9372197066	9372197042	
754	Terminal Gask. Washer	9351053017	9351053017	
815-3	Terminal	9358660102	9900203047	
823-2	Fuse Holder	0501456016	0501456016	
824-4	Fuse	0600376086	0600376086	
982-1	Cord Clamp-U	9374175017	9374175017	
982-2	Cord Clamp-L	9374176014	9374176014	

OUTDOOR UNIT

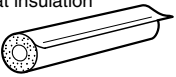

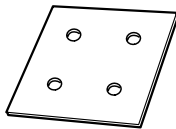
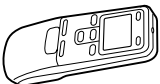
Ref. No.	Description	Part No.		Ord. Q'ty
		AOG18FNCNL	AOG18UNCNL	
2	Fan Guard	9371187013	9371187013	
4	Emblem-Rear	9372171011	9372171011	
5	Front Panel	9371924014	9371924014	
7	Connector Cover (Cabinet)	9366398004	9366398004	
8	Wire Assy (Comp)	9314792007	9314792007	
9	Side Panel R	9371927015	9371927015	
12	Base Assy	9371920054	9371920054	
13-1	3-Way Valve Assy	9314678011	9314678011	
13-2	2-Way Valve Assy	9314681011	9314681011	
16	Condenser Assy	9314473012	9314475016	
26	Compressor Cover A	9314750014	9314750014	
29	Separate Wall	9371933016	9371933016	
32	Control Box	9371935010	9371935010	
34	Capacitor, Plastic	9900089108	9900089108	
37	Running Capacitor	9307588175	9307588175	
38	Capacitor Clamp Metal	9351770013	9351770013	
39	Propeller Fan Assy	9314812019	9314812019	
41	Motor Induct	9602164011	9602165018	
45-1	Motor Bracket	9371929019	9371929019	
45-2	Motor Bracket-Top	9371931012	9371931012	
45-3	Motor Bracket Center	9371930015	9371930015	
45-4	Motor Bracket Bottom	9371932019	9371932019	
46	Compressor Assy	9372558027	9372558027	
47-1	Rubber (Discharge pipe)	313194159807	----	
51	Special Nut M5	9300301015	9300301015	
55	Special Nut M8	9355091008	9355091008	
64	Side Panel L	9371926018	9371926018	
69-3	Bolt, Hex. Socket	0700145148	0700145148	
85	Valve Plate	9371928012	9371928012	
107	Rubber Seat-A	9351049010	9351049010	
109	Terminal Cover (Comp)	9371511016	9371511016	
187	Clip (Cable)	9352715006	9352715006	
218-3	Relay	9900074012	9900074012	
259	Muffler	----	9372369012	
272	Strainer	9369287008	9369287008	
343	Solenoid	----	9900165017	
344	4-Way Valve	----	9970036019	
412	Cover Gasket (Comp.)	9371512013	9371512013	
527	Protectiive Net	9371934013	9371934013	
734	Top Panel Sub Assy	9372304013	9372304013	
735-3	Capillary Assy	9372197066	9372197042	
754	Terminal Gask. Washer	9351053017	9351053017	
815-3	Terminal	9358660102	9900203047	
823-2	Fuse Holder	0501456016	0501456016	
824-4	Fuse	0600376086	0600376086	
982-1	Cord Clamp-A	9359822011	9359822011	
982-2	Cord Clamp-B	9359823018	9359823018	
983	Compressor Cover B	9314750021	9314750021	

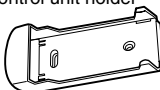
STANDARD ACCESSORIES



INDOOR UNIT

Name and Shape	Application	Part No.
Coupler heat insulation 	For indoor side pipe joint	9350716029
		9352766015
Special nut A (large flange) 	For installing indoor unit	313005446653
Special nut B (small flange) 	For installing indoor unit	313005446759
Template 	For ceiling hole cutting	9360256003
Remote control unit 	Use for air conditioner operation	9371190044 (Cooling model)
		9371190037 (Cooling & Heating model)
Battery (penlight) 	For remote control unit	0600185534
Remote control unit holder 	For mounting the remote control unit	9305642014
Tapping screw ($\phi 3 \times 12$) 	For remote control unit holder installation	0700019098

OUTDOOR UNIT (Cooling and heating model)

Name and Shape	Application	Part No.
Drain Pipe 	For outdoor unit drain piping work [Heat & Cool (Reverse cycle) model only]	9303029015
Drain Cap 		313166024302

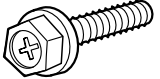
GRILLE ASSY

Name and Shape	Application	Part No.
Screw 	For opening the refrigerant valve on the outdoor unit	0700139116
Washer 	For mounting grille	0700132216
Blower cover insulation 	For discharged air	9360047007

0401G2520