

SPLIT TYPE ROOM AIR CONDITIONER

INSTALLATION MANUAL

(PART NO. 9315342195-01)

This air conditioner uses new refrigerant HFC (R410A).

The basic installation work procedures are the same as conventional refrigerant (R22) models. However, pay careful attention to the following points:

- (1) Since the working pressure is 1.6 times higher than that of conventional refrigerant (R22) models, some of the piping and installation and service tools are special. (See the table below.) Especially, when replacing a conventional refrigerant (R22) model with a new refrigerant R410A model, always replace the conventional piping and flare nuts with the R410A piping and flare nuts.
- (2) Models that use refrigerant R410A have a different charging port thread diameter to prevent erroneous charging with conventional refrigerant (R22) and for safety. Therefore, check beforehand. [The charging port thread diameter for R410A is 1/2 UNF 20 threads per inch.]
- (3) Be more careful that foreign matter (oil, water, etc.) does not enter the piping than with refrigerant (R22) models. Also, when storing the piping, securely seal the opening by pinching, taping, etc.
- (4) When charging the refrigerant, take into account the slight change in the composition of the gas and liquid phases, and always charge from the liquid phase side whose composition is stable.

Special tools for R410A

Tool name	Contents of change
Gauge manifold	Pressure is high and cannot be measured with a conventional gauge. To prevent erroneous mixing of other refrigerants, the diameter of each part has been changed. It is recommended the gauge with seals-0.1 to 5.3 MPa (-1 to 53 bar) for high pressure. -0.1 to 3.8 MPa (-1 to 38 bar) for low pressure.
Charge hose	To increase pressure resistance, the hose material and base size were changed.
Vacuum pump	A conventional vacuum pump can be used by installing a vacuum pump adapter.
Gas leakage detector	Special gas leakage detector for HFC refrigerant R410A.

Copper pipes

It is necessary to use seamless copper pipes and it is desirable that the amount of residual oil is less than 40 mg/10m. Do not use copper pipes having a collapsed, deformed or discolored portion (especially on the interior surface). Otherwise, the expansion valve or capillary tube may become blocked with contaminants.

As an air conditioner using R410A incurs pressure higher than when using R22, it is necessary to choose adequate materials. Thicknesses of copper pipes used with R410A are as shown in the table. Never use copper pipes thinner than that in the table even when it is available on the market.

CONNECTION PIPE REQUIREMENT				
Nominal diameter	Outer diameter	Thickness	Maximum length	Maximum height (between indoor and outdoor)
1/4in	6.35mm	0.8mm	30m(99ft)	20m(66ft)
5/8in	15.88mm	1.0mm		

WARNING

- (1) Do not use the existing (for R22) piping and flare nuts.
 - If the existing materials are used, the pressure inside the refrigerant cycle will rise and cause breakage, injury, etc. (Use the special R410A materials.)
- (2) When installing and relocating the air conditioner, do not mix gases other than the specified refrigerant (R410A) to enter the refrigerant cycle.
 - If air or other gas enters the refrigerant cycle, the pressure inside the cycle will rise to an abnormally high value and cause breakage, injury, etc.

CAUTION

When installing pipes shorter than 3m, sound of the outdoor unit will be transferred to the indoor unit, which will cause large operating sound or some abnormal sound.

SELECTING THE MOUNTING POSITION

- Decide the mounting position with the customer as follows:
- 1. INDOOR UNIT**
 - (1) Install the indoor unit level on a strong wall which is not subject to vibration.
 - (2) The inlet and outlet ports should not be obstructed: the air should be able to blow all over the room.
 - (3) Install the unit near an electric outlet or special branch circuit.
 - (4) Do not install the unit where it will be exposed to direct sunlight.
 - (5) Install the unit where connection to the outdoor unit is easy.
 - (6) Install the unit where the drain pipe can be easily installed.
 - (7) Take servicing, etc. into consideration and leave the spaces shown in the figure. Also install the unit where the filter can be removed.
 - 2. OUTDOOR UNIT**
 - (1) If possible, do not install the unit where it will be exposed to direct sunlight. (If necessary, install a blind that does not interfere with the air flow.)
 - (2) Do not install the unit where a strong wind blows or where it is very dusty.
 - (3) Do not install the unit where people pass.
 - (4) Take your neighbors into consideration so that they are not disturbed by air blowing into their windows or by noise.
 - (5) Provide the space shown in the figure so that the air flow is not blocked. Also for efficient operation, leave open three of the four directions front, rear, and both sides.

WARNING

Install at a place that can withstand the weight of the indoor and outdoor units and install positively so that the units will not topple or fall.

CAUTION

- (1) Do not install where there is the danger of combustible gas leakage.
- (2) Do not install near heat sources.
- (3) If children under 10 years old may approach the unit, take preventive measures so that they cannot reach the unit.
- (4) Install the indoor unit on the wall where the height from the floors more than 230 cm.

[Indoor unit piping direction]

The piping can be connected in the 7 directions in the figure. When the piping is connected in direction ①, ②, ③ or ④, cut along the piping groove in the side of the front panel with a hacksaw.

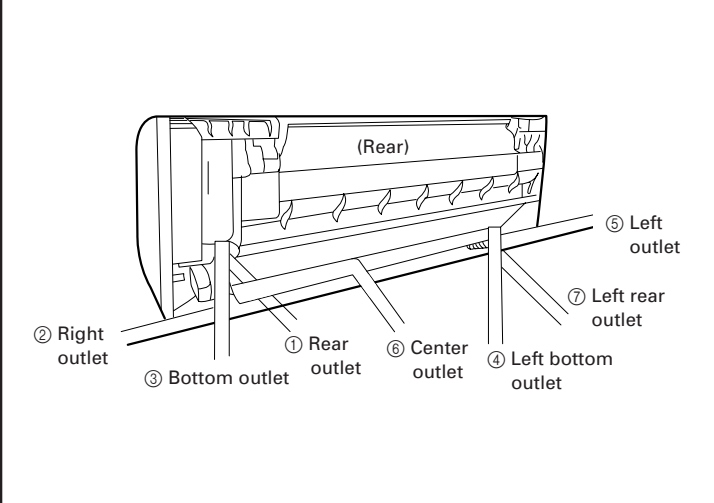

INSTALLATION DIAGRAM OF INDOOR AND OUTDOOR UNITS

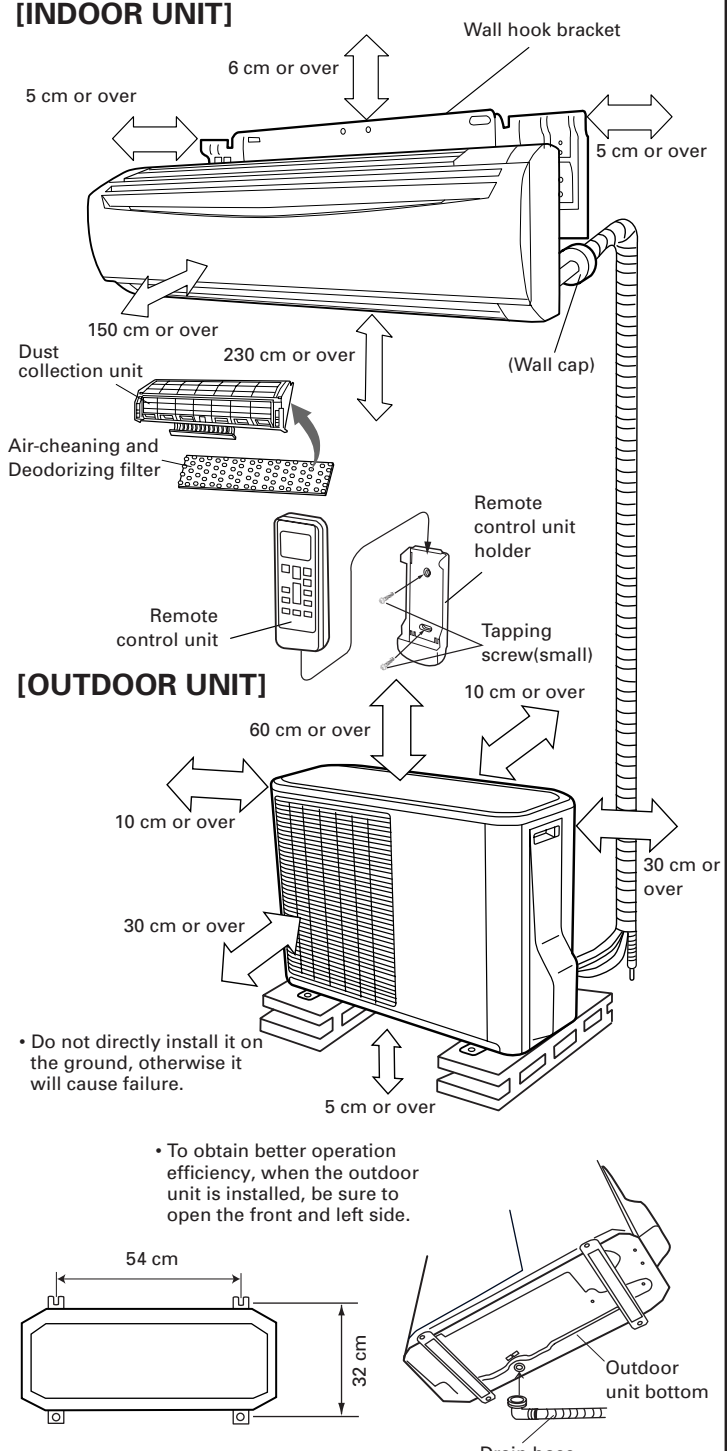

CAUTION

- (1) When the outdoor temperature is 0 °C or less, do not use the accessory drain pipe and drain cap. If the drain pipe and drain cap are used, the drain water in the pipe may freeze in extremely cold weather. (Reverse cycle model only)
- (2) In the area with heavy snowfall, if the intake and outlet of outdoor unit is blocked with snow, it might become difficult to get warm and it is likely to cause of the breakdown. Please construct a canopy and a pedestal or place the unit on a high stand (local configured).



WARNING

- (1) For the room air conditioner to operate satisfactorily, install it as outlined in this installation manual.
- (2) Connect the indoor unit and outdoor unit with the air conditioner piping and cords available standards parts. This installation manual describes the correct connections using the standard accessories and the parts specified in this installation manual.
- (3) Have installation work done by authorized service personnel only.
- (4) Do not use an extension cord.
- (5) Do not turn on the power until all installation work is complete.

- Be careful not to scratch the air conditioner when handling it.
- After installation, explain correct operation to the customer, using the operating manual.
- Let the customer keep this installation manual because it is used when the air conditioner is serviced or moved.
- The maximum length of the piping is 30 m. The maximum height difference of the piping is 20 m, if the units are further apart than these, correct operation can not be guaranteed.

STANDARD ACCESSORIES

The following installation accessories are supplied. Use them as required.

Name and Shape	Q'ty	Name and Shape	Q'ty
Wall hook bracket	1	Cloth tape	1
Remote control unit	1	Tapping screw (big)	8
Battery	2	Tapping screw (small)	2
Remote control unit holder	1	Air-cleaning and Deodorizing filter	1
Drain pipe	1	Insulation (Drain hose)	1

One set of following parts are necessary in installation of this product.

Name	
Connection pipe assembly	
Connection cord	
Wall pipe	
Decorative tape	
Vinyl tape	
Wall cap	
Saddle	
Drain hose	
Tapping screws	
Sealant	

ELECTRICAL REQUIREMENT

- Electric wire size and fuse capacity:
- | MODEL | 24,000 BTU class |
|--------------------------------------|----------------------|
| Power supply cord (mm ²) | MAX. 4.0
MIN. 3.5 |
| Connection cord (mm ²) | MAX. 2.5
MIN. 1.5 |
| Fuse capacity (A) | 30 |
- Install the disconnect device with a contact gap of at least 3 mm nearby the units. (Both indoor unit and outdoor unit)
 - Always make the air conditioner power supply a special branch circuit and provide a special breaker.
 - Always use Type245 IEC57 or equivalent as the power supply cord and the connection cord.

INDOOR UNIT

CUTTING THE HOLE IN THE WALL FOR THE CONNECTING PIPING

- (1) Cut a 80 mm diameter hole in the wall at the position shown in the figure.
- (2) When cutting the wall hole at the inside of the wall hook bracket, cut the hole to a point of intersection of center marks. When cutting the wall hole at the outside of the wall hook bracket, cut the hole at a point of 10mm below.
- (3) Cut the hole so that the outside end is lower (5 to 10 mm) than the inside end.
- (4) Always align the center of the wall hole. If misaligned, water leakage will occur.
- (5) Cut the wall pipe to match the wall thickness, stick it into the wall cap, fasten the cap with vinyl tape, and stick the pipe through the hole. (The connection pipe is supplied in the installation set.)
- (6) For left piping and right piping and center piping, cut the hole a little lower so that drain water will flow freely.

INSTALLING THE WALL HOOK BRACKET

- (1) Install the wall hook bracket so that it is correctly positioned horizontally and vertically. If the wall hook bracket is tiled, water will drip to the floor.
- (2) Install the wall hook bracket so that it is strong enough to withstand the weight of an adult.
- Fasten the wall hook bracket to the wall with 6 or more screws through the holes near the outer edge of the bracket.
- Check that there is no rattle at the wall hook bracket.

WARNING

If the wall pipe is not used, the cord interconnecting the indoor and outdoor units may touch metal and cause electric leakage.

CAUTION

Install the wall hook bracket horizontally and perpendicularly.

FORMING THE DRAIN HOSE AND PIPE

(Rear piping, Right piping, Bottom piping)

- Install the indoor unit piping in the direction of the wall hole and bind the drain hose and pipe together with vinyl tape.
- Install the piping so that the drain hose is at the bottom.
- Wrap the pipes of the indoor unit that are visible from the outside with decorative tape.

(For Left rear piping, Left piping)

Interchange the drain cap and the drain hose.

CAUTION

- (1) In order to align the drain hose and drain cap, be sure to insert securely and vertically. Incline insertion will cause water leakage.
- (2) When inserting, be sure not to attach any material besides water. If any other material is attached, it will cause deterioration and water leakage.
- (3) After removing drain hose, be sure not to forget mounting drain cap.
- (4) Be sure to fix the drain hose with tape to the bottom of piping.
- (5) Prevent drain water frozen under low temperature environment.

When installing indoor unit's drain hose outdoors, necessary measure for frost protection should be taken to prevent drain water frozen.

- Under low temperature environment (when outdoor temperature under 0 °C), after cooling operation is executed, water in the drain hose could be frozen. Once drain water is frozen, the drain hose will be blocked and water leakage may be resulted for indoor unit.

CONNECTING THE PIPING CONNECTION

- (1) Install the outdoor unit wall cap (supplied with the optional installation set or procure at the site) to the wall pipe.
- (2) Connect the outdoor unit and indoor unit piping.
- (3) After matching the center of the flare surface and tightening the nut hand tight, tighten the nut to the specified tightening torque with a torque wrench.

FLARING

- (1) Cut the connection pipe to the necessary length with a pipe cutter.
- (2) Hold the pipe downward so that cuttings will not enter the pipe and remove the burrs.
- (3) Insert the flare nut onto the pipe and flare the pipe with a flaring tool.

Insert the flare nut (always use the flare nut attached to the indoor and outdoor units respectively) onto the pipe and perform the flare processing with a flare tool.

Use the special R410A flare tool, or the conventional (for R22) flare tool.

When using the conventional flare tool, always use an allowance adjustment gauge and secure the A dimension shown in the table.

Flare nut	Tightening torque	L dimension
6.35 mm dia.	16 to 18 N·m (160 to 180 kgf·cm)	1.4 to 1.7mm
15.88 mm dia.	63 to 75 N·m (630 to 750 kgf·cm)	2.2 to 2.4mm

Pipe outside diameter

Pipe outside diameter	Flash tool for R410A, clutch type	A (mm)
φ 6.35 mm (1/4")	0 to 0.5	1.0 to 1.5
φ 15.88 mm (5/8")	0 to 0.5	1.0 to 1.5

CAUTION

- (1) Fasten a flare nut with a torque wrench as instructed in this manual. If fastened too tight, the flare nut may be broken after a long period of time and cause a leakage of refrigerant.
- (2) During installation, make sure that the refrigerant pipe is attached firmly before you run the compressor. Do not operate the compressor under the condition of refrigerant piping not attached properly with 2-way or 3-way valve open. This may cause abnormal pressure in the refrigeration cycle that leads to breakage and even injury.

INDOOR UNIT WIRING

- (1) Remove the cord clamp.
- (2) Bend the end of the connection cord as shown in the figure.
- (3) Connect the end of the connection cord fully into the terminal block.
- (4) Fasten the connection cord with a cord clamp.

HOW TO CONNECT WIRING TO THE TERMINALS

A. For solid core wiring (or F-cable)

- (1) Cut the wire end with a wire cutter or wire-cutting pliers, then strip the insulation to about 25 mm (1") to expose the solid wire.
- (2) Using a screwdriver, remove the terminal screw(s) on the terminal board.
- (3) Using pliers, bend the solid wire to form a loop suitable for the terminal screw.
- (4) Shape the loop wire properly, place it on the terminal board and tighten securely with the terminal screw using a screwdriver.

B. For strand wiring

- (1) Cut the wire end with a wire cutter or wire-cutting pliers, then strip the insulation to about 10 mm (3/8") to expose the strand wiring.
- (2) Using a screwdriver, remove the terminal screw(s) on the terminal board.
- (3) Using a round terminal fastener or pliers, securely clamp a round terminal to each stripped wire end.
- (4) Position the round terminal wire, and replace and tighten the terminal screw using a screwdriver.

CAUTION

- (1) Match the terminal block numbers and connection cord colors with those of the outdoor unit. Erroneous wiring may cause burning of the electric parts.
- (2) Connect the connection cords firmly to the terminal block. Imperfect installation may cause a fire.
- (3) Always fasten the outside covering of the connection cord with the cord clamp. (If the insulator is chafed, electric leakage may occur.)
- (4) Securely earth the power cord plug.
- (5) Do not use the earth screw for an external connector. Only use for interconnection between two units.

- For left piping and left rear piping, align the marks on the wall hook bracket and shape the connection pipe.
- Bend the connection piping at the bend radius of 100 mm or more and install no more than 35 mm from the wall.
- After passing the indoor piping and drain hose through the wall hole, hang the indoor unit on the hooks at the top and bottom of the wall hook bracket.

[Installing the indoor unit]

- Hang the indoor unit from the hooks at the top of the wall hook bracket.
- Insert the spacer, etc. between the indoor unit and the wall hook bracket and separate the bottom of the indoor unit from the wall.

FRONT PANEL REMOVAL AND INSTALLATION

AIR CLEANING UNIT REMOVAL

- (1) Open the intake grille, and then remove the right air filter.
- (2) Pull the air cleaning unit grip in the direction of the arrow and remove the unit.

AIR CLEANING UNIT INSTALLATION

- (1) Open the intake grille, and then insert the dust collection unit into the indoor unit.
- (2) Install the right air filter, and then close the intake grille.

THE INTAKE GRILLE REMOVAL

- (1) Open the intake grille.
- (2) Pull down the knob.
- (3) Lift the intake grille upward, until the axle at the top of the intake grille is removed.

THE INTAKE GRILLE INSTALLATION

- (1) The fixing axle of the intake grille is installed on the Panel.
- (2) Lay down the intake grille.

THE FRONT PANEL REMOVAL

- (1) Remove intake grille. (Reference the intake grille removal.)
- (2) Remove seven screws.
- (3) The thumb is hung on the lower part as shown in the figure, and it pulls to the front, pushing [-] mark, and bottom hooks (two position) is removed from wall hook bracket.
- (4) The front panel is pulled to the front, raising the upper surface, and a front panel is removed.

THE FRONT PANEL INSTALLATION

- (1) Firstly, fit the lower part of the front panel, and insert top and bottom hooks. (Three top screws.)
- (2) Six screws is attached.
- (3) The intake grille is attached.

CAUTION

Install the front panel and INTAKE GRILLE securely. If installation is imperfect, the front panel or INTAKE GRILLE may fall off and cause injury.

REMOTE CONTROL UNIT INSTALLATION

CAUTION

- (1) Check that the indoor unit correctly receives the signal from the remote control unit, then install the remote control unit holder.
- (2) Select the remote control unit holder selection site by paying careful attention to the following:
 - Avoid places in direct sunlight.
 - Select a place that will not be affected by the heat from a stove, etc.

1. REMOTE CONTROL UNIT HOLDER INSTALLATION

- Install the remote control unit with a distance of 7 m between the remote control unit and the photocell as the criteria. However, when installing the remote control unit, check that it operates positively.
- Install the remote control unit holder to a wall, pillar, etc. with the tapping screw.

CUSTOMER GUIDANCE

Explain the following to the customer in accordance with the operating manual:

- (1) Starting and stopping method, operation switching, temperature adjustment, timer, air flow switching, and other remote control unit operations.
- (2) Air filter removal and cleaning, and how to use the air louvers.
- (3) Give the operating and installation manuals to the customer.

PUMP DOWN OPERATION (FORCED COOLING OPERATION)

To avoid discharging refrigerant into the atmosphere at the time of relocation or disposal, recover refrigerant by doing the cooling operation or forced cooling operation according to the following procedure. (When the cooling operation cannot start in winter, and so on, start the forced cooling operation.)

- (1) Do the air purging of the charge hose by connecting the charging hose of gauge manifold to the charging port of 3 way valve and opening the low-pressure valve slightly.
- (2) Close the valve stem of 2 way valve completely.
- (3) Start the cooling operation or following forced cooling operation.

When using the remote control unit

Press the TEST RUN button after starting the cooling operation by the remote control unit. The operation indicator lamp and timer indicator lamp will begin to flash simultaneously during test run.

When using the MANUAL AUTO button of the indoor unit (The remote control unit is lost, and so on.)

Keep on pressing the MANUAL AUTO button of the indoor unit for more than 10 seconds.

(The forced cooling operation cannot start if the MANUAL AUTO button is not kept on pressing for more than 10 seconds.)

- (4) Close the valve stem of 3 way valve when the reading on the compound pressure gage becomes 0.05-0 MPa (0.5-0 kg/cm²).
- (5) Stop the operation.
 - Press the START/STOP button of the remote control unit to stop the operation.
 - Press the MANUAL AUTO button when stopping the operation from indoor unit side. (It is not necessary to press on keeping for more than 10 seconds.)

CAUTION

During the pump-down operation, make sure that the compressor is turned off before you remove the refrigerant piping. Do not remove the connection pipe while the compressor is in operation with 2 way or 3 way valve open. This may cause abnormal pressure in the refrigeration cycle that leads to breakage and even injury.

POWER

WARNING

- (1) The rated voltage of this product is 230 V AC 50 Hz.
- (2) Before turning on the power, check if the voltage is within the 220 V -10 % to 240 V +10 % range.
- (3) Always use a special branch circuit and install a special receptacle to supply power to the room air conditioner.
- (4) Use a circuit breaker and receptacle matched to the capacity of the air conditioner.
- (5) Do not extend the power cord.
- (6) Perform wiring work in accordance with standards so that the air conditioner can be operated safely and positively.
- (7) Install a leakage circuit breaker in accordance with the related laws and regulations and electric company standards.

CAUTION

- (1) The power source capacity must be the sum of the air conditioner current and the current of other electrical appliances. When the current contracted capacity is insufficient, change the contracted capacity.
- (2) When the voltage is low and the air conditioner is difficult to start, contact the power company the voltage raised.

CAUTION

Install heat insulation around both the gas and liquid pipes. Failure to do so may cause water leaks. Use heat insulation with heat resistance above 120 °C. (Reverse cycle model only)

In addition, if the humidity level at the installation location of the refrigerant piping is expected to exceed 70%, install heat insulation around the refrigerant piping. If the expected humidity level is 70-80%, use heat insulation that is 15 mm or thicker and if the expected humidity exceeds 80%, use heat insulation that is 20 mm or thicker.

If heat insulation is used that is not as thick as specified, condensation may form on the surface of the insulation. In addition, use heat insulation with heat conductivity of 0.045 W/(m·K) or less (at 20 °C).

OUTDOOR UNIT

OUTDOOR UNIT INSTALLATION

- Set the unit on a strong stand, such as one made of concrete blocks to minimize shock and vibration.
- Do not set the unit directly on the ground because it will cause trouble.

Connector cover removal

- Remove the tapping screws.
- Installing the connector cover**
- (1) After inserting the two front hooks, then insert the rear hook.
 - (2) Tighten the tapping screws.

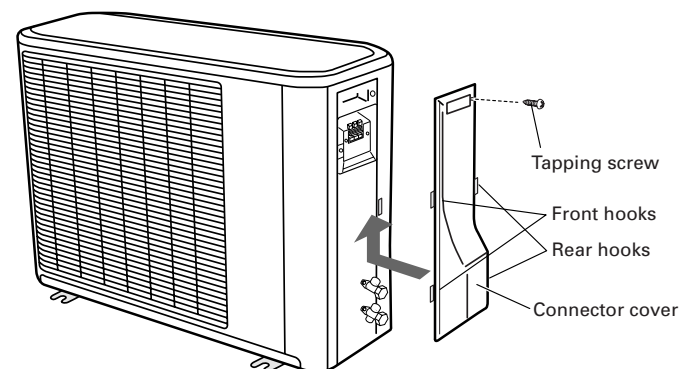

WARNING

- (1) Install the unit where it will not be tilted by more than 5°.
- (2) When installing the outdoor unit where it may be exposed to strong wind, fasten it securely.

AIR PURGE

Always use a vacuum pump to purge the air. Refrigerant for purging the air is not charged in the outdoor unit at the factory.

Close the high pressure side valve of the gauge manifold fully and do not operate it during the following work.

1. Check if the piping connections are secure.

2. Check that the stems of 2-way valve and 3-way valve are closed fully.

3. Connect the gauge manifold charge hose to the charging port of the 3-way valve (side with the projection for pushing in the valve core).

4. Open the low pressure side valve of the gauge manifold fully.

5. Operate the vacuum pump and start pump down.

6. Slowly loosen the flare nut of the 3-way valve and check if air enters, then retighten the flare nut. (When the flare nut is loosened the operating sound of the vacuum pump changes and the reading of the compound pressure gauge goes from minus to zero.)

7. Pump down the system for at least 15 minutes, then check if the compound pressure gauge reads -0.1 MPa (-76 cmHg, -1 bar).

8. At the end of pump down, close the low pressure side gauge of the gauge manifold fully and stop the vacuum pump.

9. Slowly loosen the valve stem of the 3-way valve. When the compound pressure gauge reading reaches 0.1-0.2 MPa, retighten the valve stem and disconnect the charge hose from the 3-way valve charging port. (If the stem of the 3-way valve is opened fully before the charge hose is disconnected, it may be difficult to disconnect the charge hose.)

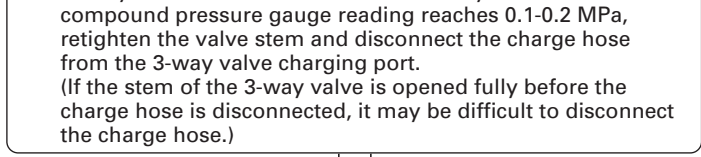

Additional charge

Refrigerant suitable for a piping length of 15 m is charged in the outdoor unit at the factory. When the piping is longer than 15 m, additional charging is necessary. For the additional amount, see the table below.

Pipe length	20 m	25 m	30 m
Additional refrigerant	100 g	200 g	300 g

CAUTION

- (1) Refrigerant must not be discharged into atmosphere.
- (2) After connecting the piping, check the joints for gas leakage with gas leak detector.

10. Fully open the valve stems of the 2-way valve and 3-way valve using a hexagon wrench. (After the valve stem begins to turn, turn it with a torque of less than 2.9 N·m (30 kgf·cm) until it stops turning.)

11. Firmly tighten the 2-way valve and 3-way valve blank cap and the charging port cap.

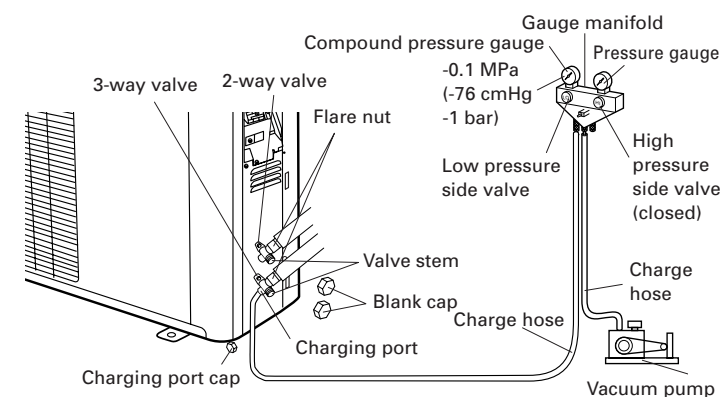

	Tightening torque
Blank cap (2-way valve)	20 to 25 N·m (200 to 250 kgf·cm)
Blank cap (3-way valve)	30 to 35 N·m (300 to 350 kgf·cm)
Charging port cap	10 to 12 N·m (100 to 120 kgf·cm)

CAUTION

- (1) When adding refrigerant, add the refrigerant from the charging port at the completion of work.
- (2) The maximum length of the piping is 30 m. If the units are further apart than this, correct operation can not be guaranteed.

Between 15 m and 30 m, when using a connection pipe other than that in the table, charge additional refrigerant with 20g/1 m as the criteria.

OUTDOOR UNIT WIRING

- (1) Remove the outdoor unit connector cover.
- (2) Bend the end of the cord as shown in the figure.
- (3) Connect the end of the connection cord fully into the terminal block.
- (4) Fasten the sheath with a cord clamp.
- (5) Install the connector cover.

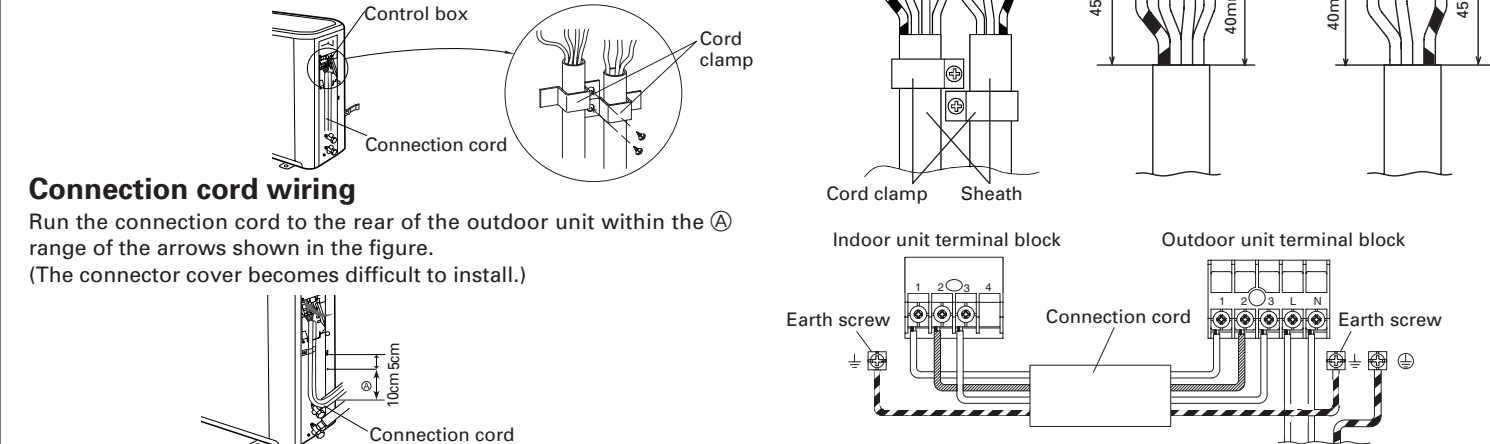

Connection cord wiring

Run the connection cord to the rear of the outdoor unit within the range of the arrows shown in the figure. (The connector cover becomes difficult to install.)

CAUTION

- (1) Match the terminal block numbers and connection cord colors with those of the indoor unit. Erroneous wiring may cause burning of the electric parts.
- (2) Connect the connection cords firmly to the terminal block. Imperfect installation may cause a fire.
- (3) Always fasten the outside covering of the connection cord with the cord clamp. (If the insulator is chafed, electric leakage may occur.)
- (4) Securely earth the power cord plug.
- (5) Do not use the earth screw for an external connector. Only use for interconnection between two units.

FINISHING

- (1) Insulate between pipes.
 - For rear, right, and bottom piping, overlap the connection pipe heat insulation and indoor unit pipe heat insulation and bind them with vinyl tape so that there is no gap.
 - For left and left rear piping and center piping, butt the connection pipe heat insulation and indoor unit pipe heat insulation together and bind them with and vinyl tape so that there is no gap.
 - For left and left rear piping and center piping, wrap the area which accommodates the rear piping housing section with cloth tape.
 - For left and left rear piping and center piping, bind the connection cord to the top of the pipe with vinyl tape.
 - For left and left rear piping and center piping, bundle the piping and drain hose together by wrapping them with cloth tape over the range within which they fit into the rear piping housing section.
- (2) Temporarily fasten the connection cord along the connection pipe with vinyl tape. (Wrap to about 1/3 the width of the tape from the bottom of the pipe so that water does not enter.)
- (3) Fasten the connection pipe to the outside wall with saddles, etc.
- (4) Fill the gap between the outside wall pipe hole and the pipe with sealer so that rain water and wind cannot blow in.
- (5) Fasten the drain hose to the outside wall, etc.



TEST RUNNING

- Perform test operation and check items 1 and 2 below.
- For the test operation method, refer to the operating manual.
- The outdoor unit, may not operate, depending on the room temperature. In this case, press the test run button on the remote control unit while the air conditioner is running. (Point the transmitter section of the remote control unit toward the air conditioner and press the test run button with the tip of a ball-point pen, etc.)
- To test operation, press the remote control unit START/STOP button. (When the air conditioner is run by pressing the test run button, the OPERATION indicator lamp and TIMER indicator lamp will simultaneously flash slowly.)

1. INDOOR UNIT

- (1) Is operation of each button on the remote control unit normal?
- (2) Does each lamp light normally?
- (3) Do the air flow-direction louver operate normally?
- (4) Is the drain normal?

2. OUTDOOR UNIT

- (1) Is there any abnormal noise and vibration during operation?
- (2) Will noise, wind, or drain water from the unit disturb the neighbors?
- (3) Is there any gas leakage?

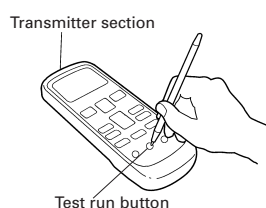

Test run button