

SPLIT TYPE ROOM AIR CONDITIONER INSTALLATION MANUAL

(PART No. 9316421011-04)

This air conditioner uses new refrigerant HFC (R410A).

The basic installation work procedures are the same as conventional refrigerant (R22) models. However, pay careful attention to the following points:

- Since the working pressure is 1.6 times higher than that of conventional refrigerant (R22) models, some of the piping and installation and service tools are special. (See the table below.) Especially, when replacing a conventional refrigerant (R22) model with a new refrigerant R410A model, always replace the conventional piping and flare nuts with the R410A piping and flare nuts.
- Models that use refrigerant R410A have a different charging port thread diameter to prevent erroneous charging with conventional refrigerant (R22) and for safety. Therefore, check beforehand. [The charging port thread diameter for R410A is 1/2 threads per inch.]
- Be more careful that foreign matter (oil, water, etc.) does not enter the piping than with refrigerant (R22) models. Also, when storing the piping, securely seal the opening by pinching, taping, etc.
- When charging the refrigerant, take into account the slight change in the composition of the gas and liquid phases, and always charge from the liquid phase side whose composition is stable.

Special tools for R410A

| Tool name | Contents of change |
|----------------------|--|
| Gauge manifold | Pressure is high and cannot be measured with a conventional gauge. To prevent erroneous mixing of other refrigerants, the diameter of each port has been changed. It is recommended the gauge with seals 0.1 to 5.3 MPa (-1 to 53 bar) for high pressure. -0.1 to 3.8 MPa (-1 to 38 bar) for low pressure. |
| Charge hose | To increase pressure resistance, the hose material and base size were changed. |
| Vacuum pump | A conventional vacuum pump can be used by installing a vacuum pump adapter. |
| Gas leakage detector | Special gas leakage detector for HFC refrigerant R410A. |

Copper pipes

It is necessary to use seamless copper pipes and it is desirable that the amount of residual oil is less than 40 mg/10m. Do not use copper pipes having a collapsed, deformed or discolored portion (especially on the interior surface). Otherwise, the expansion valve or capillary tube may become blocked with contaminants.

As an air conditioner using R410A incurs pressure higher than when using R22, it is necessary to choose adequate materials. Thicknesses of copper pipes used with R410A are as shown in Table 1. Never use copper pipes thinner than 0.8mm even when it is available on the market.

Table 1 Thicknesses of Annealed Copper Pipes

| Nominal diameter | Outer diameter (mm) | Thickness (mm) | |
|------------------|---------------------|----------------|------------|
| | | R410A | [ref.] R22 |
| 1/4 | 6.35 | 0.80 | 0.80 |
| 3/8 | 9.52 | 0.80 | 0.80 |
| 1/2 | 12.7 | 0.80 | 0.80 |

WARNING

- Do not use the existing (for R22) piping and flare nuts.
 - If the existing materials are used, the pressure inside the refrigerant cycle will rise and cause breakage, injury, etc. (Use the special R410A materials.)
- When installing and relocating the air conditioner, do not mix gases other than the specified refrigerant (R410A) to enter the refrigerant cycle.
 - If air or other gas enters the refrigerant cycle, the pressure inside the cycle will rise to an abnormally high value and cause breakage, injury, etc.

CAUTION

When installing pipes shorter than 3m, sound of the outdoor unit will be transferred to the indoor unit, which will cause large operating sound or some abnormal sound.

For authorized service personnel only.

WARNING

- For the room air conditioner to operate satisfactory, install it as outlined in this installation manual.
- Connect the indoor unit and outdoor unit with the air conditioner piping and cords available standards parts. This installation manual describes the correct connections using the standard accessories and the parts specified in this installation manual.
- Have installation work done by authorized service personnel only.
- Also do not use an extension cord.
- Do not turn on the power until all installation work is complete.

- Be careful not to scratch the air conditioner when handling it.
- After installation, explain correct operation to the customer, using the operating manual.
- Let the customer keep this installation manual because it is used when the air conditioner is serviced or moved.

STANDARD ACCESSORIES

The following installation accessories are supplied. Use them as required.

| Name and Shape | Q'ty | Name and Shape | Q'ty |
|----------------------------|------|-----------------------|------|
| Wall hook bracket | 1 | Cloth tape | 1 |
| Remote control unit | 1 | Tapping screw (big) | 9 |
| Battery | 2 | Tapping screw (small) | 2 |
| Remote control unit holder | 1 | Air cleaning filter | 2 |

One set of following parts are necessary in installation of this product.

| Name |
|--------------------------|
| Connection pipe assembly |
| Connection cord |
| Wall pipe |
| Decorative tape |
| Vinyl tape |
| Wall cap |
| Saddle |
| Drain hose |
| Tapping screws |
| Sealant |

ELECTRICAL REQUIREMENT

Always make the air conditioner power supply a special branch circuit and provide a special switch and receptacle. Do not extend the power cord.

- Electric wire size.

| MODEL | 9,000 -14,000 BTU class |
|------------------------------------|-------------------------|
| Connection cord (mm ²) | 1.5 |

- Install the disconnect device with a contact gap of at least 3 mm nearby the units. (Both indoor unit and outdoor unit)
- Always make the air conditioner power supply a special branch circuit and provide a special breaker.
- Always use H07RN-F or equivalent as the power supply cord and the connection cord.

POWER

WARNING

- The rated voltage of this product is 230 V AC 50 Hz.
- Before turning on the power, check if the voltage is within the 220 V -10 % to 240 V +10 % range.
- Always use a special branch circuit and install a special receptacle to supply power to the room air conditioner.
- Use a circuit breaker and receptacle matched to the capacity of the air conditioner.
- Do not extend the connection cord.
- Perform wiring work in accordance with standards so that the air conditioner can be operated safely and positively.
- Install a leakage circuit breaker in accordance with the related laws and regulations and electric company standards.

CAUTION

- The power source capacity must be the sum of the air conditioner current and the current of other electrical appliances. When the current contracted capacity is insufficient, change the contracted capacity.
- When the voltage is low and the air conditioner is difficult to start, contact the power company the voltage raised.

SELECTING THE MOUNTING POSITION

Decide the mounting position with the customer as follows:

- Install the indoor unit level on a strong wall which is not subject to vibration.
- The inlet and outlet ports should not be obstructed: the air should be able to blow all over the room.
- Install the unit near an electric outlet or special branch circuit.
- Do not install the unit where it will be exposed to direct sunlight.
- Install the unit where connection to the outdoor unit is easy.
- Install the unit where the drain pipe can be easily installed.
- Take servicing, etc. into consideration and leave the spaces shown in (Fig. 1). Also install the unit where the filter can be removed.
- Install the place where is no gap around the unit.

WARNING

Install at a place that can withstand the weight of the indoor and install positively so that the units will not topple or fall.

CAUTION

- Do not install where there is the danger of combustible gas leakage.
- Do not install near heat sources.
- If children under 10 years old may approach the unit, take preventive measures so that they cannot reach the unit.

CUSTOMER GUIDANCE

Explain the following to the customer in accordance with the operating manual:

- Starting and stopping method, operation switching, temperature adjustment, timer, air flow switching, and other remote control unit operations.
- Air filter removal and cleaning, and how to use the air louvers.
- Give the operating and installation manuals to the customer.

INSTALLATION DIAGRAM OF INDOOR UNIT

Fig. 1 [INDOOR UNIT]

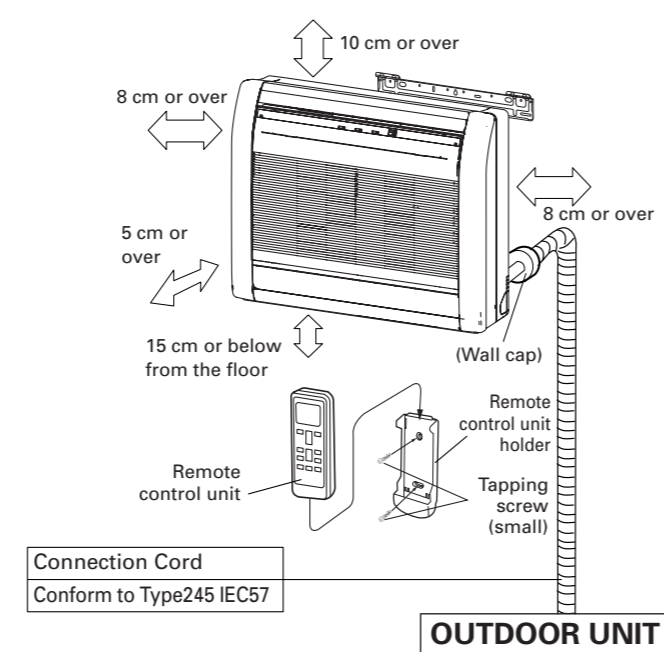

[Indoor unit piping direction]

The piping can be connected in the six directions indicated by ①, ②, ③, ④, ⑤, and ⑥ in (Fig. 2). When the piping is connected in direction ② or ⑤, cut along the piping groove in the side of the base with a hacksaw. When connecting the piping in direction ③, ④, cut a notch in the thin wall at the front bottom of the base.

Fig. 2

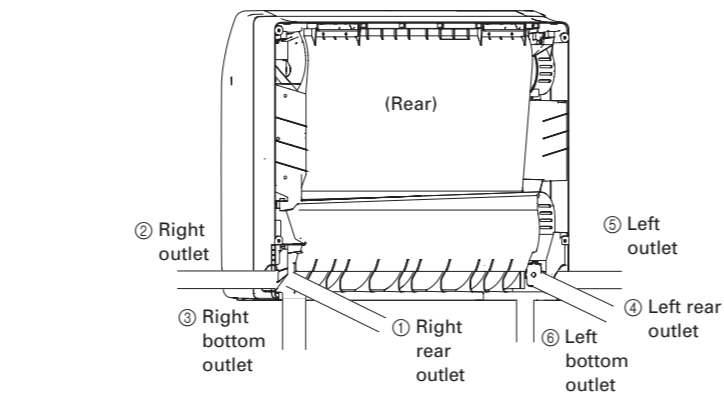
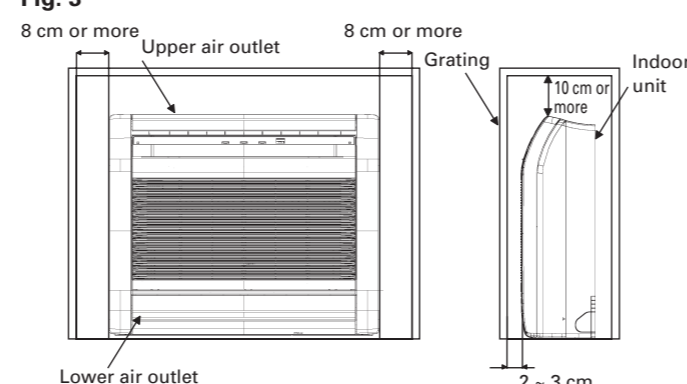

Fig. 3



EMBEDDING THE INDOOR UNIT IN A WALL

- When installing a grating, use a grating with narrow upper and lower horizontal bars so that the airflow from the upper and lower air outlets does not contact the bars. If the horizontal bars will block the lower air outlet, use a stand, etc., to adjust the height of the indoor unit. If the upper or lower air outlet is blocked, the air conditioner will not be able to cool or warm the room well.
- Do not block the receiver with the grating. Otherwise, the grating will interfere with the remote controller signal and significantly reduce the distance and area (angle) from which the signals can be received.
- Use a grating with vertical bars, etc., that has at least 75% open area. If the grating has horizontal bars or if the open area is less than 75%, performance could be reduced.
- When the indoor unit is embedded in a wall (built-in), the time it takes for the room temperature to reach the set temperature will increase.

SIDE PANEL L, R REMOVAL AND INSTALLATION

THE INTAKE GRILLE REMOVAL

- Open the intake grille.
- Remove the rope.
- Lay down the intake grille, until the axle at the bottom of the intake grille is removed.

THE INTAKE GRILLE INSTALLATION

- The fixing axle of the intake grille is installed on the Panel.
- Lift the intake grille upward.

THE SIDE PANEL L, R REMOVAL

- Remove intake grille (Reference the intake grille removal.)
- Remove four screws.
- The middle finger is hung on the lower part as shown in the figure, and it pulls the front, pushing [<] mark, and bottom hooks (two position) is removed from Base.
- The side panel is pulled to the front, raising the upper surface, and a side panel is removed.

THE SIDE PANEL L, R INSTALLATION

- Firstly, fit the top part of the side panel, and insert top and bottom hooks.
- Four screws are attached.
- The intake grille is attached.

CAUTION

Install the SIDE PANEL L, R and INTAKE GRILLE securely. If installation is imperfect, the SIDE PANEL L, R or INTAKE GRILLE may fall off and cause injury.

Fig. 4

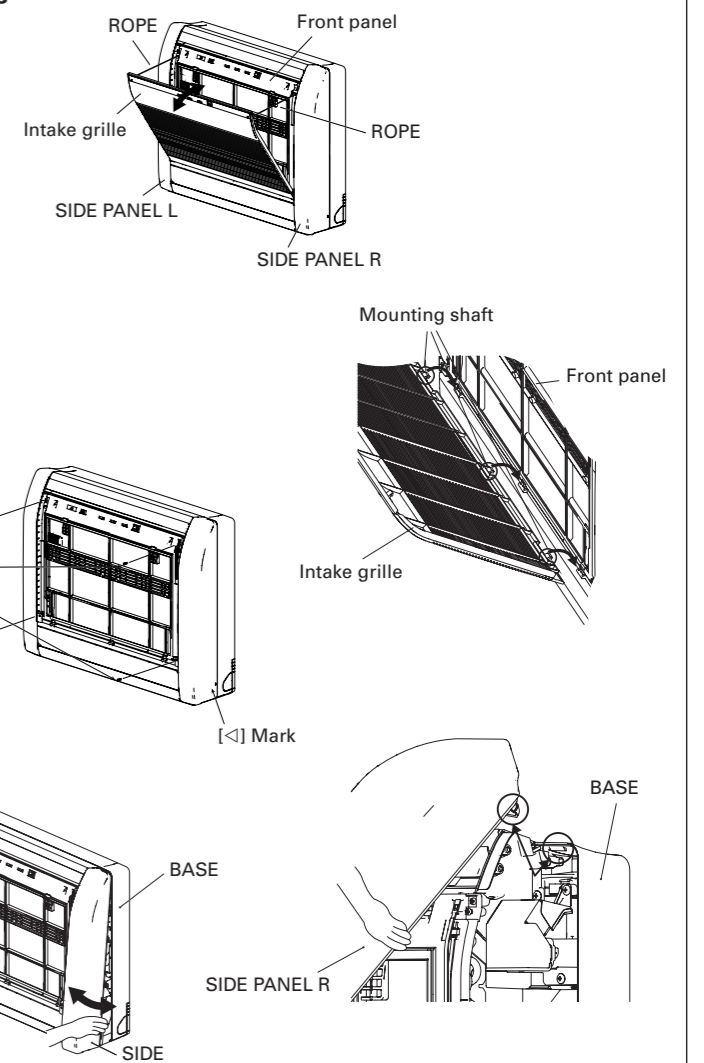

When embedding the indoor unit in a wall, restrict the movement of the horizontal vane for the upper air outlet so that it only operates horizontally. If this setting is not performed, heat will build up in the wall and the room will not be cooled or warmed properly. Please explain the vane setting of direction only horizontally to the customer.

HOW TO SETTING VANE

Perform the "FUNCTION SETTING" according to the installation condition using the remote controller.

Entering the Function Setting Mode

- While pressing the FAN button and SET TEMP simultaneously, press the RESET button to enter the function setting mode.
- Press the TIMER MODE button two times and check that the indoor unit can receive signal.
- Selecting the function number and setting value.

- Press the SET TEMP. button to select the function number. (Press the MODE button to switch between the left and right digits.)
- Press the FAN button to proceed to setting the value. (Press the FAN button again to return to the function number selection.)
- Press the SET TEMP. button to select the setting value. (Press the MODE button to switch between the left and right digits.)
- Press the TIMER MODE button, and START/STOP button, in the order listed to confirm the settings.
- Press the RESET button to cancel the function setting mode.
- After completing the FUNCTION SETTING, be sure to turn off the power and turn it on again.

| FUNCTION SETTING | SETTING VALUE |
|------------------|---------------|
| 23 | 2 |

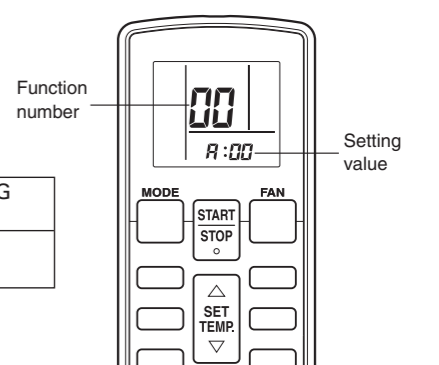

CUTTING THE HOLE IN THE WALL FOR THE CONNECTING PIPING

- Cut a 65 mm diameter hole in the wall at the position shown in (Fig. 5).
- Always align the center of the wall hole. If misaligned, water leakage will occur.
- Cut the wall pipe to match the wall thickness, stick it into the wall cap, fasten the cap with vinyl tape, and stick the pipe through the hole. (The connection pipe is supplied in the installation set.) (Fig. 5)
- For left piping and right piping, cut the hole a little lower so that drain water will flow freely. (Fig. 5)

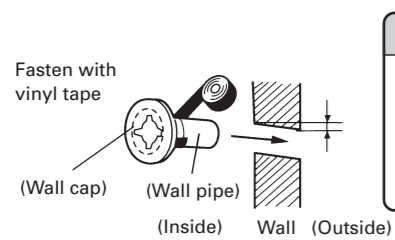

WARNING
If the wall pipe is not used, the cord interconnecting the indoor and outdoor units may touch metal and cause electric leakage.

Fig. 5

FOR RIGHT or LEFT REAR PIPING
(The following figure is a front view of the indoor unit installation location.)

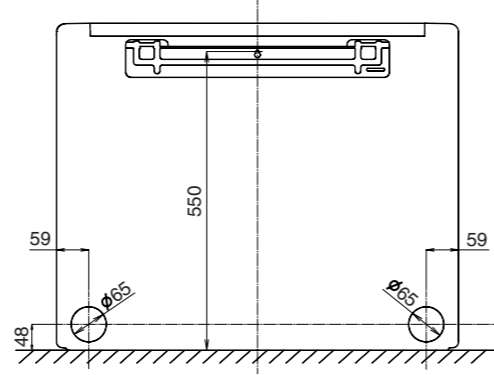

FORMING PIPE

- Pass the refrigerant pipe through the piping hole to indoor side.
- Arrange the pipes according to the direction of piping.

Fig. 6

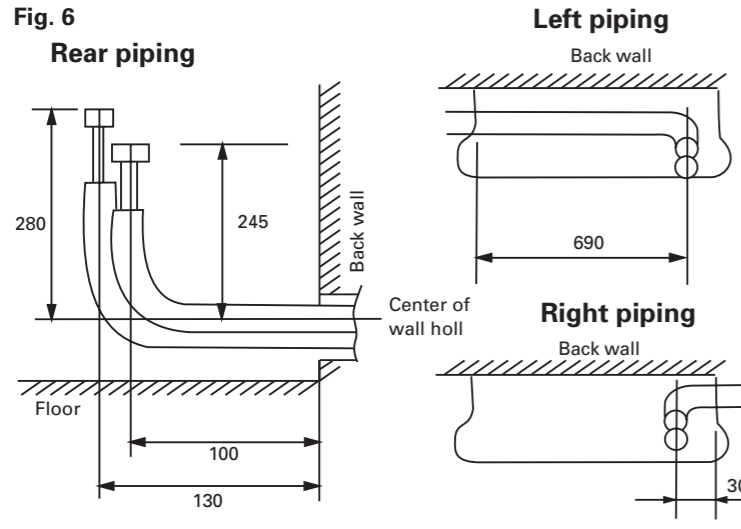

FOR RIGHT or LEFT Bottom PIPING
FOR LEFT PIPING FOR RIGHT PIPING

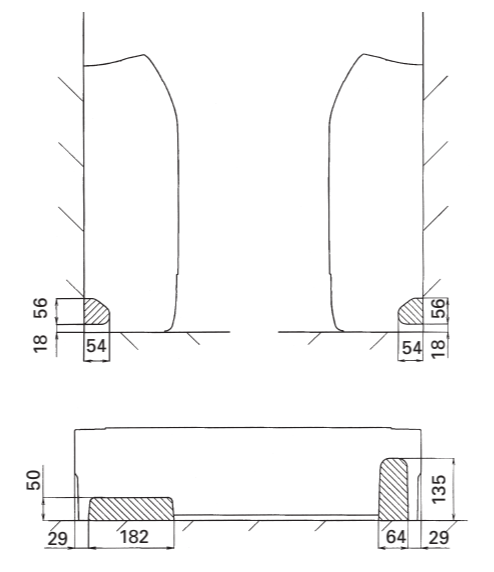

INDOOR UNIT INSTALLATION

- Use the included and fasten the indoor unit at 4 locations (⇨) each at top and the middle of the unit.
- When the unit is set to the wall, use the wall hook bracket and hook the top of the indoor unit on the indoor unit wall hook bracket.

WARNING

[Installation of indoor unit]
• Fix the indoor unit with 4 screws surely. If improperly installed, might cause to injury due to the toppling or falling.
• Install the indoor unit at the place that has adequate strength.
Install the indoor unit so that the installed unit can withstand the weight of adult body weight.
If improperly installed, might cause accidental injury due to the toppling or falling.

Fig. 7

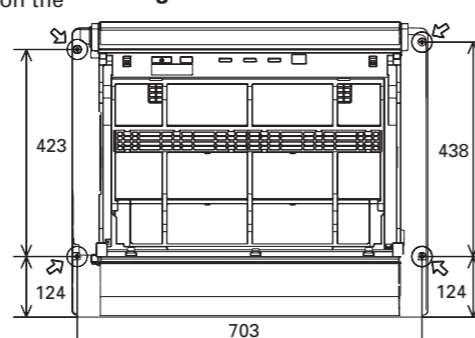

INSTALLING THE WALL HOOK BRACKET

- Install the wall hook bracket so that it is correctly positioned horizontally and vertically. If the wall hook bracket is tiled, water will drip to the floor.
- Install the wall hook bracket so that it is strong enough to withstand the weight of an adult.
- Fasten the wall hook bracket to the wall with 5 or more screws through the holes near the outer edge of the bracket.
- Check that there is no rattle at the wall hook bracket.

Fig. 8

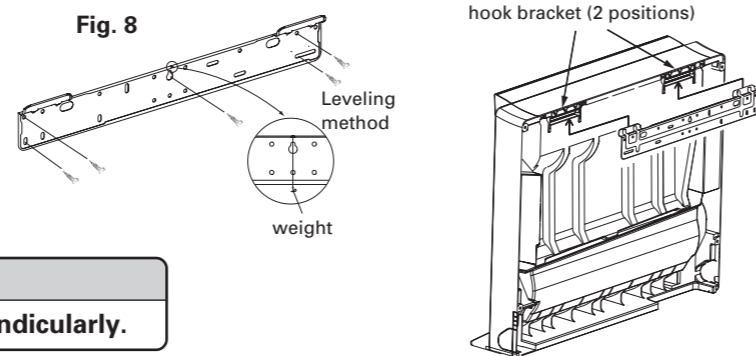

CAUTION

Install the wall hook bracket horizontally and perpendicularly.

INDOOR UNIT WIRING

- Remove the terminal cover.
- Remove the cord clamp.
- Bend the end of the connection cord as shown in the figure.

Fig. 11

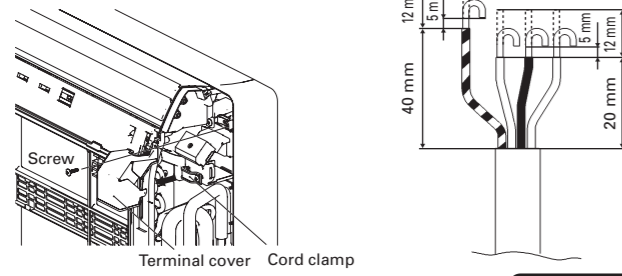

- Connect the end of the connection cord fully into the terminal block.
- Fasten the connection cord with a cord clamp.

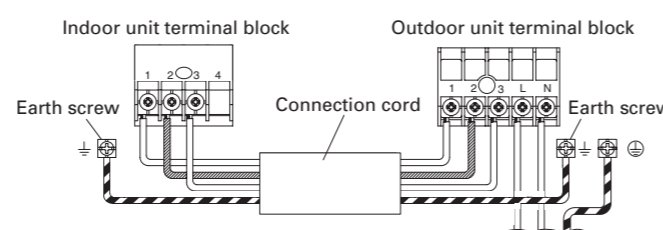

CAUTION

- Match the terminal block numbers and connection cord colors with those of the outdoor unit. Erroneous wiring may cause burning of the electric parts.
- Connect the connection cords firmly to the terminal block. Imperfect installation may cause a fire.
- Always fasten the outside covering of the connection cord with the cord clamp. (If the insulator is chafed, electric leakage may occur.)
- Securely earth the connection cord.
- Do not use the earth screw for an external connector. Only use for inter-connection between two units.

WARNING

Place the terminal cover surely after connecting the connection cable with the terminal of the indoor unit.
If not placed the terminal cover, might cause smoke emission or fire.

CONNECTION STATEMENT OF WIRE

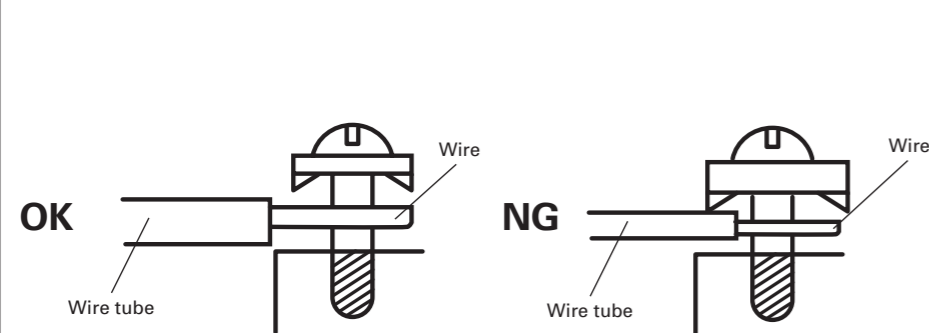

TREATMENT OF WIRE

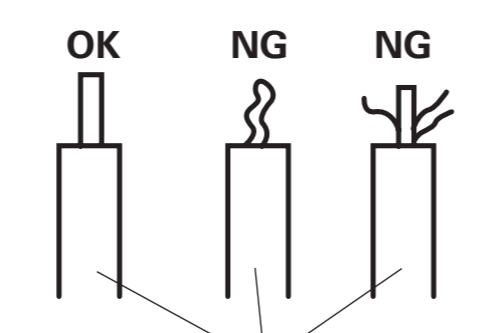

FINISHING

- Insulate between pipes.
- Overlap the connection pipe heat insulation and indoor unit pipe heat insulation.
- Wrapping the connection pipe with cloth tape over the range within which they fit into the rear piping housing section.
- Fasten the pipe bracket with the screw (Fig. 12).
- Fill the gap between the outside wall pipe hole and the pipe with sealer so that rain water and wind cannot blow in.
- Fasten the drain hose to the outside wall, etc.

Fig. 12

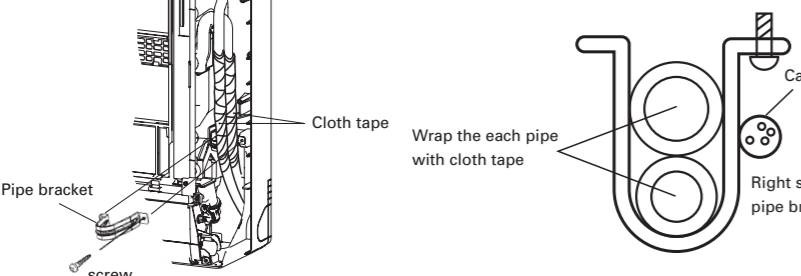
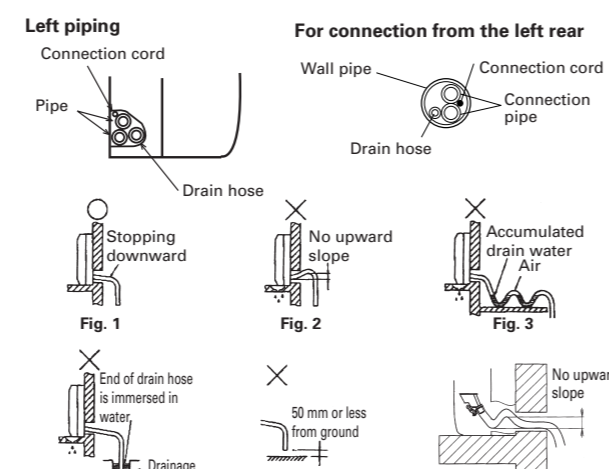

Fig. 13



NOTE ON DRAIN HOSE

The drain hose can be connected at either side of the indoor unit.

The unit has been shipped with the drain hose connected at left (viewed from the back of the unit) and the drain cap applied at right.

- Remove the both side panels.
- Remove the screw and remove the drain holder from drain pan.
- Pull out the drain cap.
- Connect the drain hose to the right, attach the screw and insert the drain cap to the left.

Fig. 7

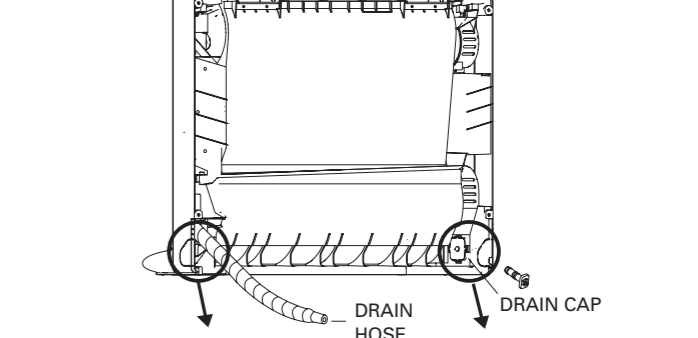

CAUTION

- In order to align the drain hose and drain cap, be sure to insert securely and vertically. Incline insertion will cause water leakage.
- When inserting, be sure not to attach any material besides water. If any other material is attached, it will cause deterioration and water leakage.
- After removing drain hose, be sure not to forget mounting drain cap.
- Be sure to fix the drain hose with tape to the bottom of piping.

Installation method of Drain cap

- Use a hexagonal wrench (4mm at opposite side) to insert the drain cap, till the drain cap contacts the tip of drain cock.

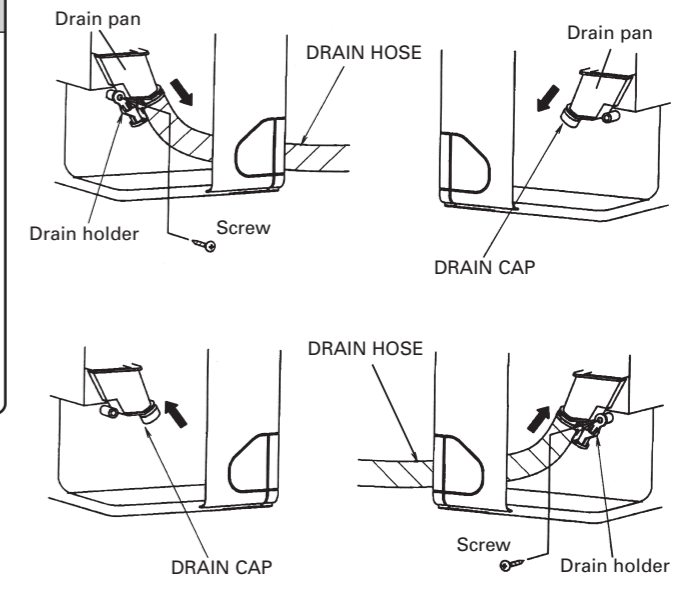
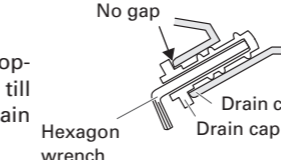

CONNECTING THE PIPING

CONNECTION

- Install the outdoor unit wall cap (supplied with the optional installation set or procured at the site) to the wall pipe.
- Connect the outdoor unit and indoor unit piping.
- After matching the center of the flare surface and tightening the nut hand tight, tighten the nut to the specified tightening torque with a torque wrench. (Table 2)

FLARING

- Cut the connection pipe to the necessary length with a pipe cutter. Check if (L) is flared uniformly and is not cracked or scratched.
- Hold the pipe downward so that cuttings will not enter the pipe and remove the burrs.
- Insert the flare nut onto the pipe and flare the pipe with a flaring tool.

Insert the flare nut (always use the flare nut attached to the indoor and outdoor units respectively) onto the pipe and perform the flare processing with a flare tool. Use the special R410A flare tool, or the conventional (for R22) flare tool. When using the conventional flare tool, always use an allowance adjustment gauge and secure the A dimension shown in table 3.

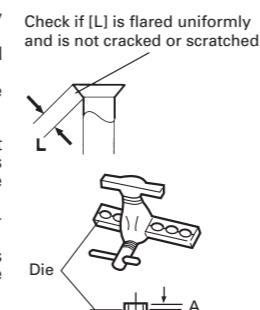

Fig. 10

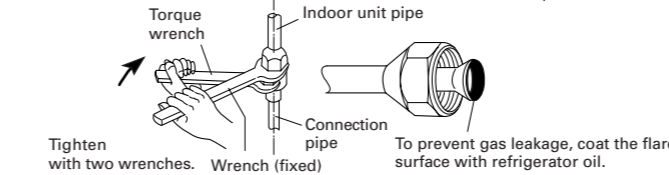

Table 2 Flare nut size and tightening torque

| Flare nut | Diameter (mm) × Torque (N·m) |
|--------------|------------------------------|
| 6.35 mm dia. | 17 × 14 - 18 |
| 9.52 mm dia. | 22 × 34 - 42 |
| 12.7 mm dia. | 26 × 49 - 61 |

Table 3 Pipe outside diameter

| Pipe outside diameter | Flare tool for R410A, clutch type | A (mm) | |
|-----------------------|-----------------------------------|-------------------------------|---------------|
| | | Conventional (R22) flare tool | Wing nut type |
| φ 6.35 mm (1/4") | 0 to 0.5 | 1.0 to 1.5 | 1.5 to 2.0 |
| φ 9.52 mm (3/8") | 0 to 0.5 | 1.0 to 1.5 | 1.5 to 2.0 |
| φ 12.7 mm (1/2") | 0 to 0.5 | 1.0 to 1.5 | 1.5 to 2.0 |

CAUTION

- Fasten a flare nut with a torque wrench as instructed in this manual. If fastened too tight, the flare nut may be broken after a long period of time and cause a leakage of refrigerant.
- During installation, make sure that the refrigerant pipe is attached firmly before you run the compressor. Do not operate the compressor under the condition of refrigerant piping not attached properly with 2-way or 3-way valve open. This may cause abnormal pressure in the refrigeration cycle that leads to breakage and even injury.

TEST RUNNING

- Perform test operation and check items 1 and 2 below.
- For the test operation method, refer to the operating manual.
- The outdoor unit, may not operate, depending on the room temperature. In this case, press the test run button on the remote control unit while the air conditioner is running. (Point the transmitter section of the remote control unit toward the air conditioner and press the test run button with the tip of a ball-point pen, etc.)
- To end test operation, press the remote control unit START/STOP button. (When the air conditioner is run by pressing the test run button, the OPERATION indicator lamp and TIMER indicator lamp will simultaneously flash slowly.)

1. INDOOR UNIT

- Is operation of each button on the remote control unit normal?
- Does each lamp light normally?
- Do the air flow-direction louver operate normally?
- Is the drain normal?

2. OUTDOOR UNIT

- Is there any abnormal noise and vibration during operation?
- Will noise, wind, or drain water from the unit disturb the neighbors?
- Is there any gas leakage?

Fig. 14

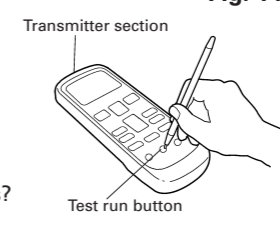

WIRED REMOTE CONTROL UNIT (OPTIONAL)

1. SIDE PANEL L AND CONTROL COVER REMOVAL

- Refer to "SIDE PANEL LR REMOVAL AND INSTALLATION" to remove the side panel L.
- Remove the control cover.

2. CONNECTING TO CONTROL UNIT OF WIRE

- Connect the wire of wired remote control unit to the circuit board and screw the earth wire.
- Install the control cover.
- Use wire clasper and screw to fasten wire.

3. SIDE PANEL L INSTALLATION

Install side panel L by the reverse procedure as stated in "1 SIDE PANEL L AND CONTROL COVER REMOVAL".

CAUTION

- Before installing, be sure to disconnect all power supply.
- During installing or removing operation, be sure not to have wire caught by parts or draw it hard. Or it may result troubles to the air-conditioner.
- Insure the length of wire is not over the recommended maximum length.
- Before setting up the wired remote control unit, please confirm whether air-conditioner can receive the signal.

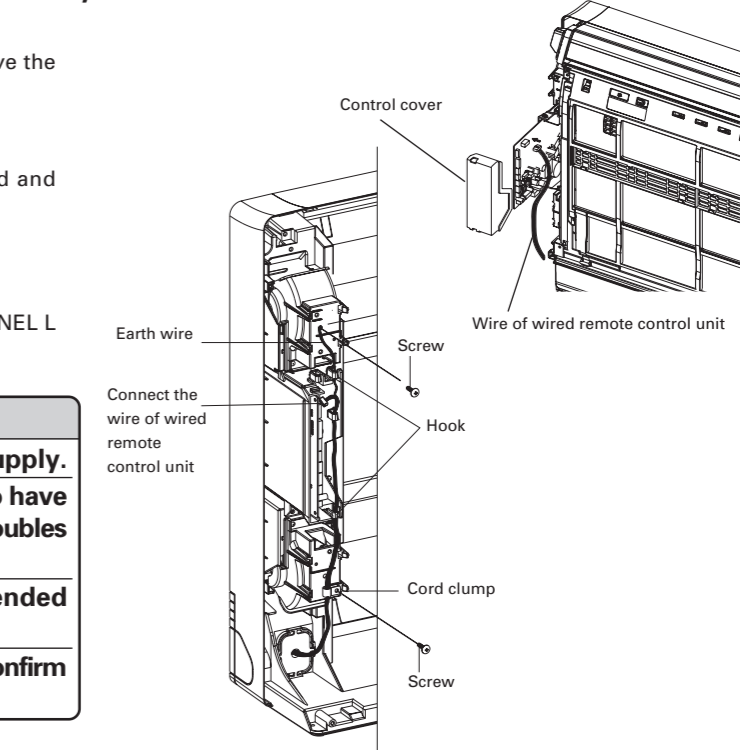

PUMP DOWN OPERATION (FORCED COOLING OPERATION)

To avoid discharging refrigerant into the atmosphere at the time of relocation or disposal, recover refrigerant by doing the cooling operation or forced cooling operation according to the following procedure. (When the cooling operation cannot start in winter, and so on, start the forced cooling operation.)

- Do the air purging of the charge hose by connecting the charging hose of gauge manifold to the charging port of 3 way valve and opening the low-pressure valve slightly.
- Close the valve stem of 2 way valve completely.
- Start the cooling operation or following forced cooling operation.
 - When using the remote control unit
 - Press the TEST RUN button after starting the cooling operation by the remote control unit. The operation indicator lamp and timer indicator lamp will begin to flash simultaneously during test run. When using the MANUAL AUTO button of the indoor unit (The remote control unit is lost, and so on.)
 - Keep on pressing the MANUAL AUTO button of the indoor unit for more than 10 seconds. (The forced cooling operation cannot start if the MANUAL AUTO button is not kept on pressing for more than 10 seconds.)
 - Close the valve stem of 3 way valve when the reading on the compound pressure gage becomes 0.05-0 Mpa (0.5-0 kg/cm²).
- Stop the operation.
 - Press the START/STOP button of the remote control unit to stop the operation.
 - Press the MANUAL AUTO button when stopping the operation from indoor unit side. (It is not necessary to press on keeping for more than 10 seconds.)

CAUTION

During the pump-down operation, make sure that the compressor is turned off before you remove the refrigerant piping.
Do not remove the connection pipe while the compressor is in operation with 2 way or 3 way valve open. This may cause abnormal pressure in the refrigeration cycle that leads to breakage and even injury.