

AIR CONDITIONER (SPLIT TYPE)

For general public use

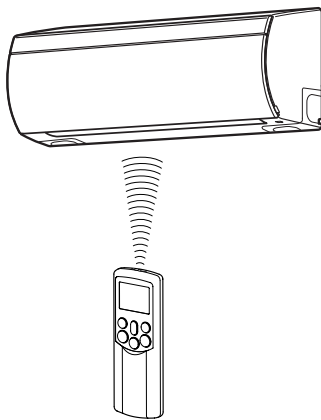

ENGLISH

EN

Indoor Unit	Outdoor Unit
RAS-07PKVP-E	RAS-07PAVP-E
RAS-10PKVP-E	RAS-10PAVP-E
RAS-13PKVP-E	RAS-13PAVP-E
RAS-16PKVP-E	RAS-16PAVP-E
RAS-18PKVP-E	RAS-18PAVP-E
RAS-07PKVP-ND	RAS-07PAVP-ND
RAS-10PKVP-ND	RAS-10PAVP-ND
RAS-13PKVP-ND	RAS-13PAVP-ND
RAS-16PKVP-ND	RAS-16PAVP-ND
RAS-18PKVP-ND	RAS-18PAVP-ND

CONTENTS

ENGLISH



1	PRECAUTION FOR SAFETY	1
2	INSTALLATION DIAGRAM OF INDOOR AND OUTDOOR UNITS	4
3	OPTIONAL PARTS, ACCESSORIES AND TOOLS	5
4	INSTALLATION OF INDOOR UNIT	7
5	INSTALLATION OF OUTDOOR UNIT	14
6	TEST OPERATION	18
7	REMOVING THE MAIN PARTS	19

* Please read this installation manual carefully before installing the air conditioner.

1 PRECAUTION FOR SAFETY

Be sure to read this installation manual carefully before installing.
The supplied CD-ROM contains the installation manual translated into many languages.
Recommend to the owner to perform maintenance periodically when using over long periods of time.

Be sure to follow the precautions provided here to avoid safety risks.
The symbols and their meanings are shown below.

 DANGER	It indicates that incorrect use of this unit can result in a high possibility of severe injury(*1) or death.
 WARNING	It indicates that incorrect use of this unit may cause severe injury or death.
 CAUTION	It indicates that incorrect use of this unit may cause personal injury(*2), or property damage(*3).

*1: A severe injury refers to blindness, injury, burns (hot or cold), electrical shock, bone fracture, or poisoning that leaves aftereffects and requires hospitalization or extended out-patient treatment.

*2: Personal injury means a slight accident, burn, or electrical shock which does not require admission or repeated hospital treatment.

*3: Property damage means greater damage which affects assets or resources.

For general public use

Power supply cord of parts of appliance for outdoor use shall be at least polychloroprene sheathed flexible cord (design H07RN-F) or cord designation 60245 IEC66 (1.5 mm² or more). (Shall be installed in accordance with national wiring regulations.)

CAUTION

New refrigerant air conditioner installation

THIS AIR CONDITIONER USES THE NEW HFC REFRIGERANT (R410A), WHICH DOES NOT DESTROY THE OZONE LAYER.

R410A refrigerant is apt to be affected by impurities such as water, oxidizing membranes, and oils because the pressure of R410A refrigerant is approx. 1.6 times of refrigerant R22. As well as the adoption of this new refrigerant, refrigerating machine oil has also been changed. Therefore, during installation work, be sure that water, dust, former refrigerant, or refrigerating machine oil does not enter the refrigeration cycle of a new-refrigerant air conditioner. To avoid mixing refrigerant and refrigerating machine oil, the sizes of charging port connecting sections on the main unit are different from those for the conventional refrigerant, and different size tools are also required. For connecting pipes, use new and clean piping materials with highpressure withstand capabilities, designed for R410A only, and ensure that water or dust does not enter. Moreover, do not use any existing piping as its pressure withstand may be insufficient and may contain impurities.

DANGER

- FOR USE BY QUALIFIED PERSONS ONLY.
- MEANS FOR DISCONNECTION FROM THE SUPPLY HAVING A CONTACT SEPARATION OF AT LEAST 3 mm IN ALL POLES MUST BE INCORPORATED IN THE FIXED WIRING.
- TURN OFF MAIN POWER SUPPLY BEFORE ATTEMPTING ANY ELECTRICAL WORK. MAKE SURE ALL POWER SWITCHES ARE OFF. FAILURE TO DO SO MAY CAUSE ELECTRIC SHOCK.
- CONNECT THE CONNECTING CABLE CORRECTLY. IF THE CONNECTING CABLE IS CONNECTED WRONGLY, ELECTRIC PARTS MAY BE DAMAGED.
- CHECK THE EARTH WIRE THAT IT IS NOT BROKEN OR DISCONNECTED BEFORE INSTALLATION.
- DO NOT INSTALL NEAR CONCENTRATIONS OF COMBUSTIBLE GAS OR GAS VAPORS. FAILURE TO FOLLOW THIS INSTRUCTION CAN RESULT IN FIRE OR EXPLOSION.
- TO PREVENT OVERHEATING THE INDOOR UNIT AND CAUSING A FIRE HAZARD, PLACE THE UNIT WELL AWAY (MORE THAN 2 M) FROM HEAT SOURCES SUCH AS RADIATORS, HEATERS, FURNACE, STOVES, ETC.
- WHEN MOVING THE AIR CONDITIONER FOR INSTALLING IT IN ANOTHER PLACE AGAIN, BE VERY CAREFUL NOT TO GET THE SPECIFIED REFRIGERANT (R410A) WITH ANY OTHER GASEOUS BODY INTO THE REFRIGERATION CYCLE. IF AIR OR ANY OTHER GAS IS MIXED IN THE REFRIGERANT, THE GAS PRESSURE IN THE REFRIGERATION CYCLE BECOMES ABNORMALLY HIGH AND IT RESULTINGLY CAUSES BURST OF THE PIPE AND INJURIES ON PERSONS.
- IN THE EVENT THAT THE REFRIGERANT GAS LEAKS OUT OF THE PIPE DURING THE INSTALLATION WORK, IMMEDIATELY LET FRESH AIR INTO THE ROOM. IF THE REFRIGERANT GAS IS HEATED BY FIRE OR SOMETHING ELSE, IT CAUSES GENERATION OF POISONOUS GAS.

- WHEN INSTALLING OR RE-INSTALLING THE AIR CONDITIONER, DO NOT INJECT AIR OR OTHER SUBSTANCES BESIDES THE DESIGNATED REFRIGERANT "R410A" INTO THE REFRIGERATING CYCLE. IF AIR OR OTHER SUBSTANCES ARE MIXED, AN ABNORMAL PRESSURE CAN OCCUR IN THE REFRIGERATING CYCLE, AND THIS CAN CAUSE AN INJURY DUE TO A PIPE RUPTURE.

 **WARNING**

- Installation work must be requested from the supplying retail dealership or professional vendors. Self-installation may cause water leakage, electrical shock, or fire as a result of improper installation.
- Specified tools and pipe parts for model R410A are required, and installation work must be done in accordance with the manual. HFC type refrigerant R410A has 1.6 times more pressure than that of conventional refrigerant (R22). Use the specified pipe parts, and ensure correct installation, otherwise damage and/or injury may be caused. At the same time, water leakage, electrical shock, and fire may occur.
- Be sure to install the unit in a place which can sufficiently bear its weight. If the load bearing of the unit is not enough, or installation of the unit is improper, the unit may fall and result in injury.
- Electrical work must be performed by a qualified electrical engineer in accordance with the code governing such installation work, internal wiring regulations, and the manual. A dedicated circuit and the rated voltage must be used. Insufficient power supply or improper installation may cause electrical shock or fire.
- Use a cable tie to connect wires in the indoor/outdoor units. Midway connection, stranded wire, and single-wire connections are not allowed. Improper connection or fixing may cause a fire.
- Wiring between the indoor unit and outdoor units must be well shaped so that the cover can be firmly placed. Improper cover installation may cause increased heat, fire, or electrical shock at the terminal area.
- Be sure to use only approved accessories or the specified parts. Failure to do so may cause the unit to fall, water leakage, fire or electrical shock.
- After the installation work, ensure that there is no leakage of refrigerant gas. If the refrigerant gas leaks out of the pipe into the room and is heated by fire or something else from a fanheater, stove or gas range, it causes generation of poisonous gas.
- Make sure the equipment is properly earthed. Do not connect the earth wire to a gas pipe, water pipe, lightning conductor, or telephone earth wire. Improper earth work may be the cause of electrical shock.
- Do not install the unit where flammable gas may leak. If there is any gas leakage or accumulation around the unit, it can cause a fire.
- Do not select a location for installation where there may be excessive water or humidity, such as a bathroom. Deterioration of insulation may cause electrical shock or fire.
- Installation work must be performed following the instructions in this installation manual. Improper installation may cause water leakage, electrical shock or fire. Check the following items before operating the unit.
 - Be sure that the pipe connection is well placed and there are no leaks.
 - Check that the service valve is open. If the service valve is closed, it may cause overpressure and result in compressor damage. At the same time, if there is a leak in the connection part, it may cause air suction and overpressure, resulting in damage to the unit or injury.
- In a pump-down operation, be sure to stop the compressor unit before removing the refrigerant pipe. If removing the refrigerant pipe while the compressor is operating with the service valve opened, it may cause air suction and overpressure, resulting in damage to the unit or injury.
- Do not modify the power cable, connect the cable midway, or use a multiple outlet extension cable. Doing so may cause contact failure, insulation failure, or excess current, resulting in fire or electrical shock.
- If you detect any damage, do not install the unit. Contact your supplying dealer immediately.
- Never modify this unit by removing any of the safety guards or bypassing any of the safety interlock switches.

 **CAUTION**

- Please read this installation manual carefully before installing the unit. It contains further important instructions for proper installation.
- Exposure of unit to water or other moisture before installation could result in electric shock. Do not store it in a wet basement or expose to rain or water.
- After unpacking the unit, examine it carefully for possible damage.
- Do not install in a place that can increase the vibration of the unit. Do not install in a place that can amplify the noise level of the unit or where noise and discharged air might disturb neighbors.
- This appliance must be connected to the main power supply by means of a circuit breaker depending on the place where the unit is installed. Failure to do so may cause electrical shock.
- Follow the instructions in this installation manual to arrange the drain pipe for proper drainage from the unit. Ensure that drained water is discharged. Improper drainage can result in water leakage, causing water damage to furniture.
- Tighten the flare nut with a torque wrench using the prescribed method. Do not apply excess torque. Otherwise, the nut may crack after a long period of usage and it may cause the leakage of refrigerant.

- Wear gloves (heavy gloves such as cotton gloves) for installation work. Failure to do so may cause personal injury when handling parts with sharp edges.
- Do not touch the air intake section or the aluminum fins of the outdoor unit. It may cause injury.
- Do not install the outdoor unit in a place which can be a nest for small animals. Small animals could enter and contact internal electrical parts, causing a failure or fire.
- Request the user to keep the place around the unit tidy and clean.
- Make sure to conduct a trial operation after the installation work, and explain how to use and maintain the unit to the customer in accordance with the manual. Ask the customer to keep the operation manual along with the installation manual.

REQUIREMENT OF REPORT TO THE LOCAL POWER SUPPLIER

Please make absolutely sure that the installation of this appliance is reported to the local power supplier before installation. If you experience any problems or if the installation is not accepted by the supplier, the service agency will take adequate countermeasures.

2 INSTALLATION DIAGRAM OF INDOOR AND OUTDOOR UNITS

The indoor unit shall be installed so that the top of the indoor unit is positioned at least 2 m high. Also, avoid putting anything on the top of the indoor unit.

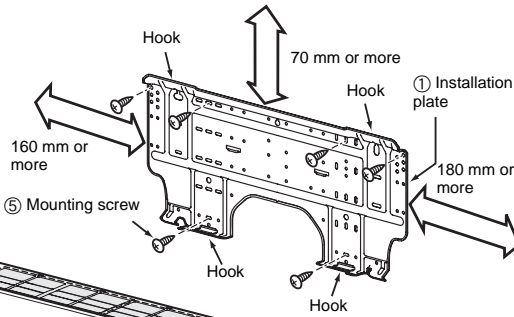

For the rear left and left piping

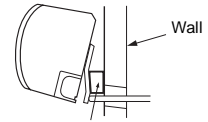

Insert the cushion between the indoor unit and wall, and tilt the indoor unit for better installation work.

Do not allow the drain hose to become slack.

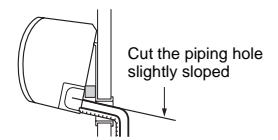

Make sure the drain hose is sloped downward.

CAUTION
Install in rooms that are 5 m³ or larger. If a leak of refrigerant gas occurs inside the room, an oxygen deficiency can occur.

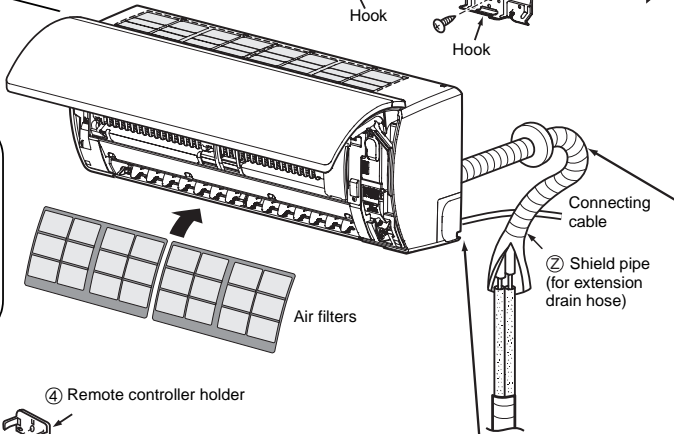

② Wireless remote controller

④ Remote controller holder



⑥ Remote controller holder mounting screw

Before installing the wireless remote controller

• With the remote controller cover removed, correctly load the supplied batteries while observing their polarity.

② Wireless remote controller

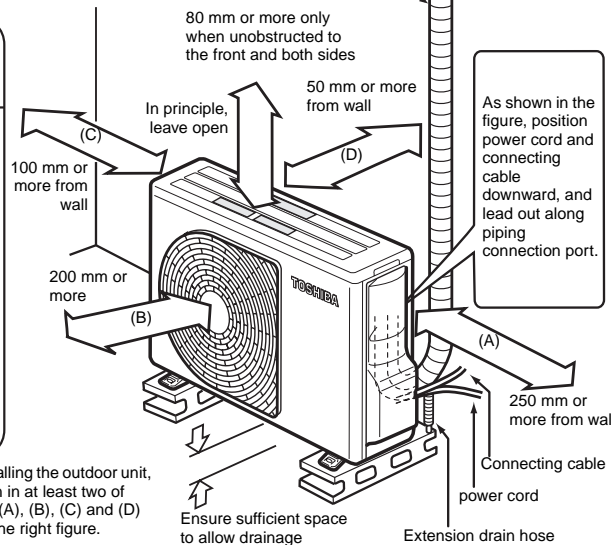
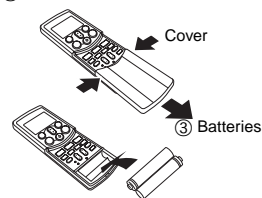

The auxiliary piping can be connected at the left, rear left, rear right, right, bottom right or bottom left as shown below.

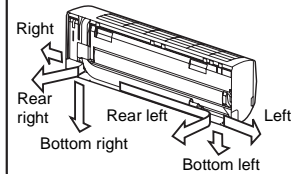

Insulate the refrigerant pipes separately, not together.

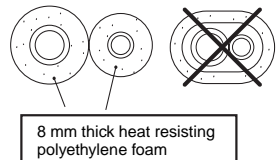

- If the system will be used in cooling mode when the outdoor temperature is below zero, take measures to ensure that the drain water does not freeze.
- When the outdoor unit is installed in a place that is always exposed to strong winds like on the coast or on a high story of a building, secure the normal fan operation using a duct or a wind shield.

CAUTION (RAS-***-ND model only)

- Use care to avoid burns. A heater is installed on the base plate of the outdoor unit. When the outside air temperature is low, the heater runs to warm the base plate even if the unit is not operating so that snow does not accumulate inside the outdoor unit.
- Do not use the supplied drain nipple for draining water. Drain the water from all the drain holes directly. Provide a space of at least 50 cm under the outdoor unit so that the draining water does not freeze and block the drain holes.

3 OPTIONAL PARTS, ACCESSORIES AND TOOLS

Optional Installation Parts





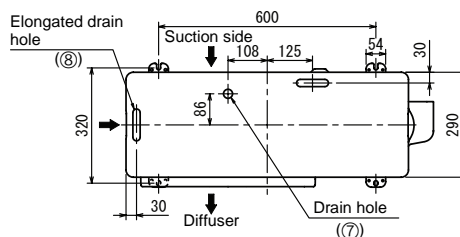

Part Code	Parts name			Q'ty
⑤	Refrigerant piping			1 ea.
	Indoor unit name	Liquid side (Outer diameter)	Gas side (Outer diameter)	
	RAS-07PKVP-E, RAS-07PKVP-ND RAS-10PKVP-E, RAS-10PKVP-ND RAS-13PKVP-E, RAS-13PKVP-ND	6.35 mm	9.52 mm	
	RAS-16PKVP-E, RAS-16PKVP-ND RAS-18PKVP-E, RAS-18PKVP-ND	6.35 mm	12.7 mm	
⑦	Shield pipe (for extension drain hose) (polyethylene foam, 8 mm thick)			1

Attachment bolt arrangement of outdoor unit

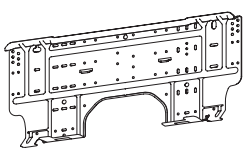
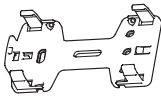
- Secure the outdoor unit with the attachment bolts and nuts if the unit is likely to be exposed to a strong wind.
- Use dia. 8 mm or dia. 10 mm anchor bolts and nuts.
- If it is necessary to drain the defrost water, attach drain nipple to the base plate of the outdoor unit before installing it.

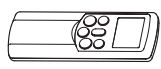

Accessory and Installation Parts

Part No.	Part name (Q'ty)	Part No.	Part name (Q'ty)	Part No.	Part name (Q'ty)
①	 Installation plate x 1	④	 Remote controller holder x 1	⑦	 Drain nipple* x 1
②	 Wireless remote controller x 1	⑤	 Mounting screw φ4 x 25L x 7	⑧	 Water-proof rubber cap* x 2
③	 Battery x 2	⑥	 Remote controller holder mounting screw φ3.1 x 16L x 2		

Others

Name
Owner's manual
Installation manual
Important information and warning*
B/W strips (Energy efficiency labels)

This model is not equipped with an extension drain hose.

- For the extension drain hose, use a commercially available one.

Parts marked with asterisk (*) are packaged with the outdoor unit.







Installation/Service Tools

Changes in the product and components

On air conditioners using R410A, in order to prevent any other refrigerant from being accidentally charged, the service port diameter size of the outdoor unit control valve (3 way valve) has been changed. (1/2 UNF 20 threads per inch)

- In order to increase the pressure resisting strength of the refrigerant piping, flare processing diameter and opposing flare nuts sizes have been changed. (for copper pipes with nominal dimensions 1/2 and 5/8)

New tools for R410A

New tools for R410A	Applicable to R22 model		Changes
Gauge manifold	×		As the working pressure is high, it is impossible to measure the working pressure using conventional gauges. In order to prevent any other refrigerant from being charged, the port diameters have been changed.
Charge hose	×		In order to increase pressure resisting strength, hose materials and port sizes have been changed (to 1/2 UNF 20 threads per inch). When purchasing a charge hose, be sure to confirm the port size.
Electronic balance for refrigerant charging	○		As working pressure is high and gasification speed is fast, it is difficult to read the indicated value by means of charging cylinder, as air bubbles occur.
Torque wrench (nominal dia. 1/2, 5/8)	×		The size of opposing flare nuts have been increased. Incidentally, a common wrench is used for nominal diameters 1/4 and 3/8.
Flare tool (clutch type)	○		By increasing the clamp bar's receiving hole size, strength of spring in the tool has been improved.
Gauge for projection adjustment	—		Used when flare is made by using conventional flare tool.
Vacuum pump adapter	○		Connected to conventional vacuum pump. It is necessary to use an adapter to prevent vacuum pump oil from flowing back into the charge hose. The charge hose connecting part has two ports — one is for conventional refrigerant (7/16 UNF 20 threads per inch) and the other is for R410A. If the vacuum pump oil (mineral) mixes with R410A, a sludge may occur and damage the equipment.
Gas leakage detector	×		Exclusive for HFC refrigerant.

- Incidentally, the “refrigerant cylinder” comes with the refrigerant designation (R410A) and protector coating in the U.S.'s ARI specified rose color (ARI color code: PMS 507).
- Also, the “charge port and packing for refrigerant cylinder” requires 1/2 UNF 20 threads per inch corresponding to the charge hose's port size.

4 INSTALLATION OF INDOOR UNIT

Installation Location

- A place which provides enough space around the indoor unit as shown in the diagram. (☞ see page 4.)
- A place where there are no obstacles near the air inlet and outlet.
- A place which allows easy installation of the piping to the outdoor unit.
- A place which allows the front panel to be opened.
- The indoor unit shall be installed so that the top of the indoor unit is positioned at least two m high. Also, avoid putting anything on the top of the indoor unit.

Remote controller

- Should be placed where there are no obstacles, such as curtains, that may block the signal.
- Do not install the remote controller in a place exposed to direct sunlight or close to a heating source, such as a stove.
- Keep the remote controller at least 1 m away from the nearest TV set or stereo equipment. (This is necessary to prevent image disturbance or noise interference.)
- Do not install near high-frequency devices or wireless devices.
- The location of the remote controller should be determined as shown below.

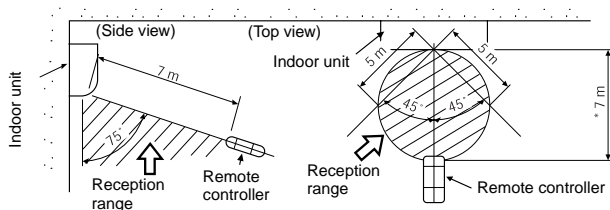

*: Axial distance

Drilling and Mounting Installation Plate

Drilling

When installing the refrigerant pipes from the rear.

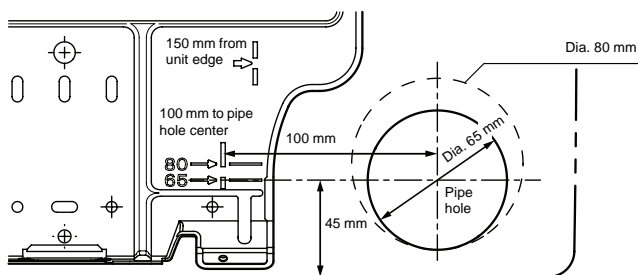

1. Decide the installation plate mounting position on the wall.
2. Mark the corresponding pipe hole wall positions according to the positioning marks (⇔) on the installation plate.
3. Drill the pipe holes (Dia. 65 mm or Dia. 80 mm) slightly slanted downward to the outside.

NOTE

- When drilling into a wall that contains a metal lath, wire lath or metal plate, be sure to use a pipe hole brim ring sold separately.
- The unit is designed to enable installation using holes of 65 mm in diameter. However, if installation is difficult, make holes that are 80 mm in diameter.

CAUTION

Completely fill in the gaps in the pipe holes with noncombustible material (such as putty) to prevent condensation and fire in the casing.

Mounting the installation plate

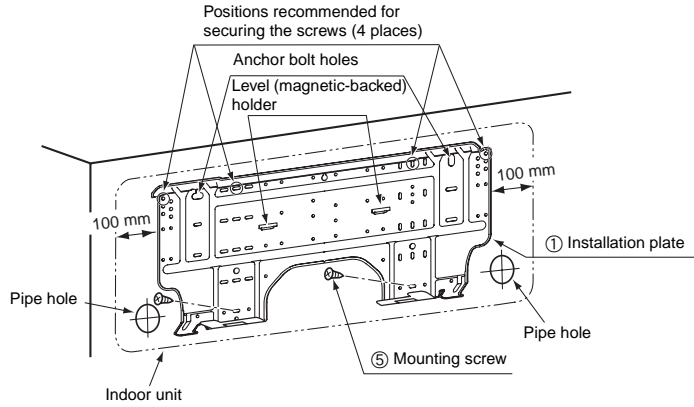

When the installation plate is directly mounted on the wall

1. Securely fit the installation plate onto the wall by screws with the upper and lower catches.
2. To mount the installation plate on a concrete wall use anchor bolts. Drill the anchor bolt holes as illustrated in the above figure.
3. Place the level at the top end of the installation plate, and check that the plate is horizontal.

CAUTION

When installing the installation plate with mounting screws, do not use anchor bolt holes. Otherwise the unit may fall down and result in personal injury and property damage.

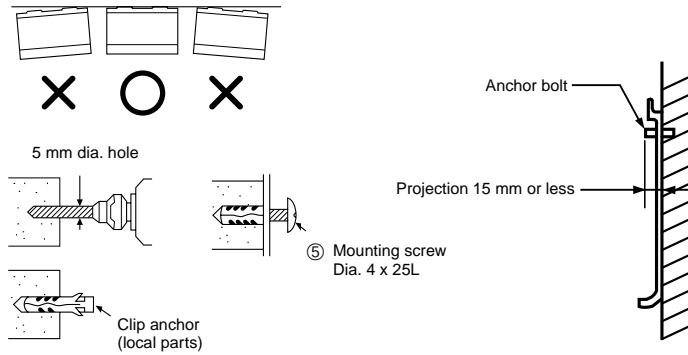

CAUTION

Failure to securely install the unit may result in personal injury and/or property damage if the unit falls.

- In case of block, brick, concrete or similar type walls, drill 5 mm dia. holes in the wall.
- Insert clip anchors for the ⑤ mounting screws.

NOTE

- Install the installation plate using between 4 to 6 mounting screws, making sure all four corners are secure.

Electrical Work

1. The supply voltage must be the same as the rated voltage of the air conditioner.
2. Prepare a power source for the exclusive use of the air conditioner.

NOTE

- Wire type: H07RN-F or 60245IEC66 (1.0 mm²)

NOTE

- Make sure the wire length is sufficient before performing wiring work.

Wiring Connection

How to connect the connecting cable

Wiring the connecting cable can be carried out without removing the front panel.

1. Pull the handles on the bottom of the right and left sides, and open the moving panel until it is horizontal.
2. Remove the terminal cover and cord clamp.
3. Insert the connecting cable (or as according to local regulations/codes) into the pipe hole on the wall.
4. Pull the connecting cable through the cable slot on the rear panel so that it protrudes about 15 cm out of the front.
5. Insert the connecting cable fully into the terminal block and secure it tightly with screws.
Make a loop with the earth wire under the terminal block and secure it with the earth screw.
6. Tightening torque: 1.2 N·m (0.12 kgf·m)
7. Secure the connecting cable with the cord clamp.
8. Attach the terminal cover and moving panel on the indoor unit.

CAUTION

- Be sure to refer to the wiring system diagram labeled inside the front panel.
- Check local electrical regulations for any specific wiring instructions or limitations.

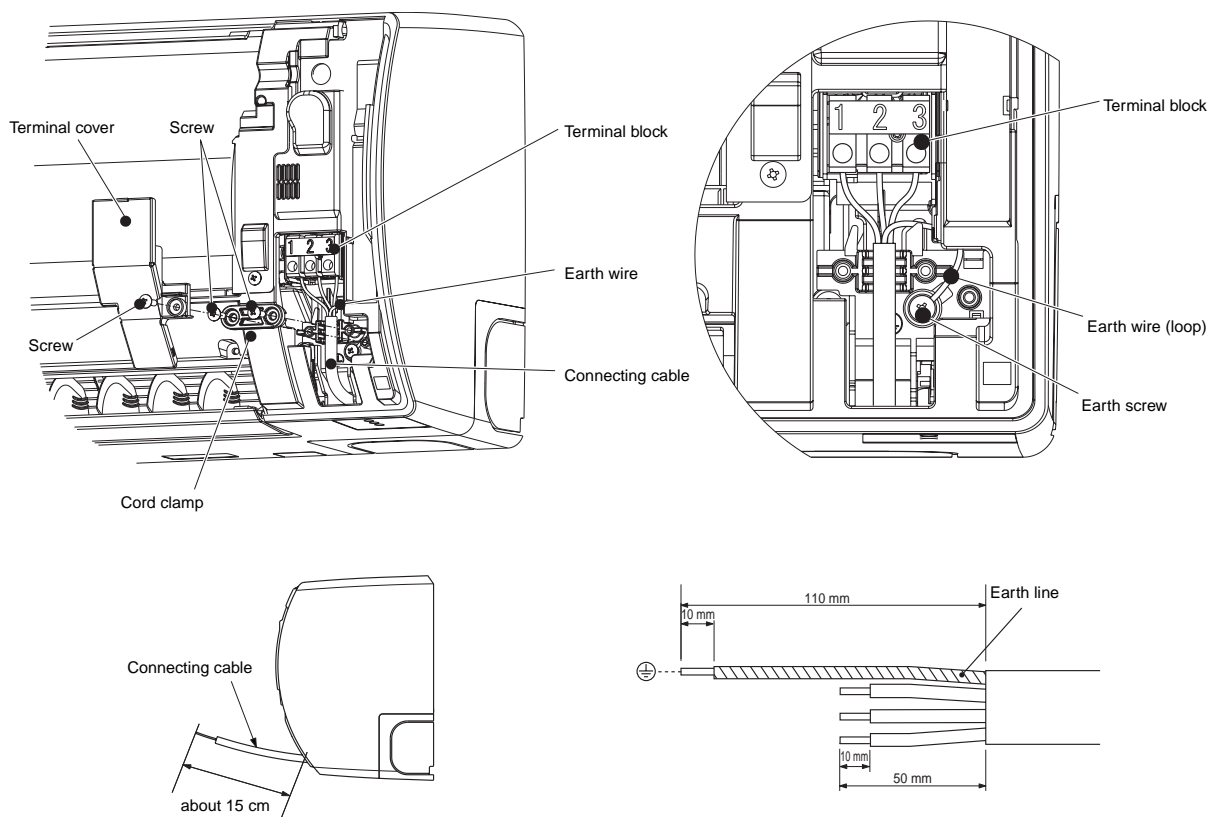

NOTE

- Connecting cable (Indoor unit/outdoor unit)
- Wire type: H07RN-F or 60245IEC66 (1.0 mm²)

Piping and Drain Hose Installation

Piping and drain hose forming

- Since condensation results in machine trouble, make sure to insulate both the connecting pipes separately. (Use polyethylene foam as insulating material.)

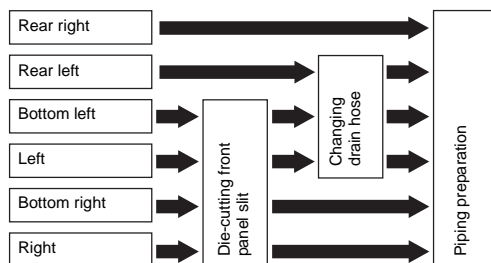

1. Die-cutting front panel slit

Cut out the slit on the left or right side of the front panel for the left or right connection and the slit on the bottom left or right side of the front panel for the bottom left or right connection with a pair of nippers.

2. Changing drain hose

For left connection, left-bottom connection and rear-left connection's piping, it is necessary to relocate the drain hose and drain cap.

• How to remove the drain cap

Clamp drain cap with needle-nose pliers, and pull out.

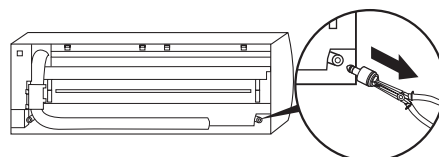

• How to remove the drain hose

The drain hose is secured in place by a screw.

Remove the screw securing the drain hose, then pull out the drain hose.

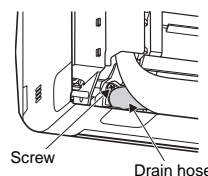

• How to attach the drain cap

1. Insert hexagonal wrench (4 mm).

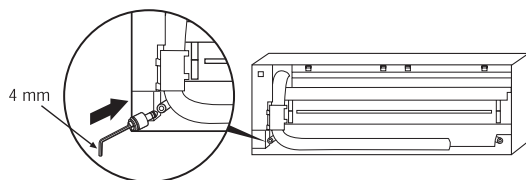

2. Firmly insert drain cap.

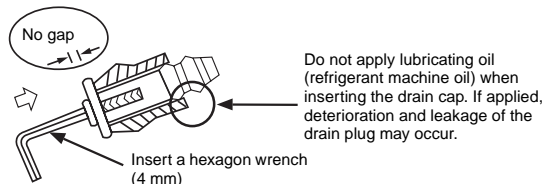

• How to attach the drain hose

Always use the original screw that secured the drain hose to the unit. Using a different screw may cause water to leak.

Insert the drain hose firmly until the connector contacts the insulation, then secure it in place using the original screw.

CAUTION

Securely insert the drain hose and drain cap; otherwise, water may leak.

INFORMATION

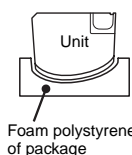

The packaged foam polystyrene can be used to make replacement of the drain cap and drain hose easier.

In case of right or left piping

- After making slits on the front panel with a knife or similar tool, cut them out with a pair of nippers or an equivalent tool.

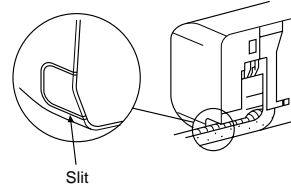

In case of bottom right or bottom left piping

- After making slits on the front panel with a knife or similar tool, cut them out with a pair of nippers or an equivalent tool.

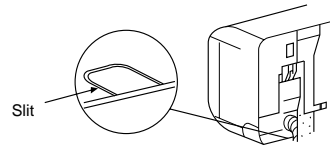

Left-hand connection with piping

Bend the connecting pipes so that they are positioned within 43 mm above the wall surface. If the connecting pipes are positioned more than 43 mm above the wall surface, the indoor unit may be unstable. When bending the connecting pipe, make sure to use a spring bender to avoid crushing the pipe.

Refer to the table below for the bending radius of each connection pipe.

Outer diameter	Bending radius
6.35 mm	30 mm
9.52 mm	40 mm
12.7 mm	50 mm

To connect the pipe after installation of the unit (figure)

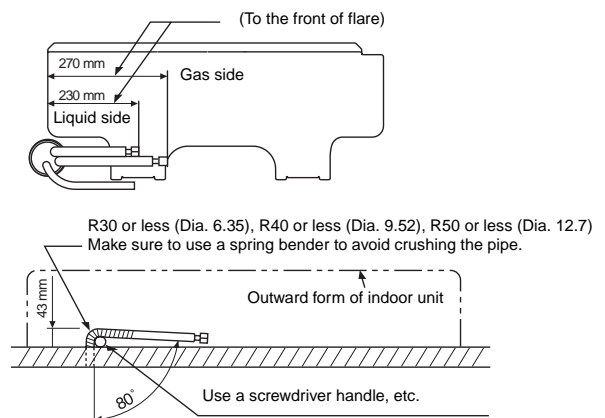

NOTE

If the pipe is incorrectly bent, the indoor unit may be unstable on the wall.

After passing the connecting pipe through the pipe hole, connect the connecting pipe to the auxiliary pipes and wrap the facing tape around them.

CAUTION

- Bind the auxiliary pipes (two) and connecting cable with facing tape tightly. In case of leftward piping and rear-leftward piping, bind the auxiliary pipes (two) only with facing tape.

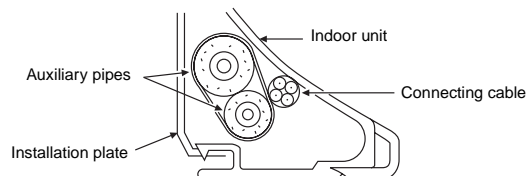

- Carefully arrange the pipes so that none of the pipes stick out of the rear plate of the indoor unit.
- Carefully connect the auxiliary pipes and connecting pipes to each other and cut off the insulating tape wound on the connecting pipe to avoid double-taping at the joint, moreover, seal the joint with the vinyl tape, etc.
- Since condensation can result in machine performance trouble, be sure to insulate both connecting pipes. (Use polyethylene foam as insulating material.)
- When bending a pipe, be careful not to crush it.

Indoor Unit Installation

1. Pass the pipe through the hole in the wall, and hook the indoor unit on the installation plate at the upper hooks.
2. Swing the indoor unit to right and left to confirm that it is firmly hooked on the installation plate.
3. While pressing the indoor unit onto the wall, hook it at the lower part on the installation plate. Pull the indoor unit toward you to confirm that it is firmly hooked on the installation plate.

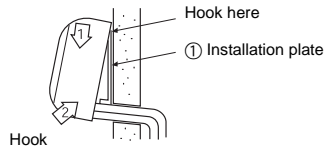

- For detaching the indoor unit from the installation plate pull the indoor unit toward you while pushing the bottom up at the specified places.

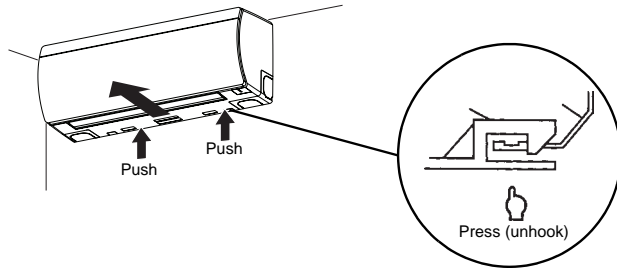

Drainage

1. Run the drain hose at a downward sloped angle.

NOTE

- Hole should be made at a slight downward slant on the outdoor side.

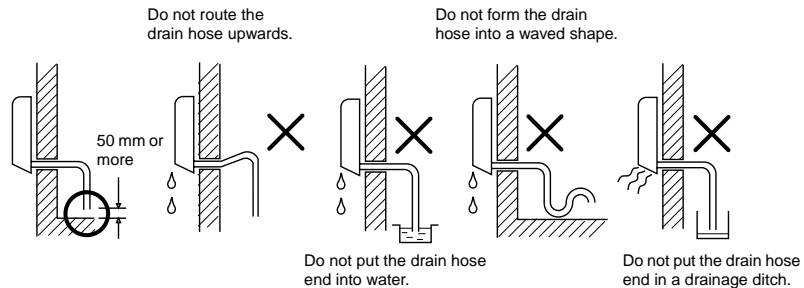

2. Put water in the drain pan and make sure that the water is being drained outside.
3. When connecting extension drain hose, insulate the connection part of extension drain hose with shield pipe.

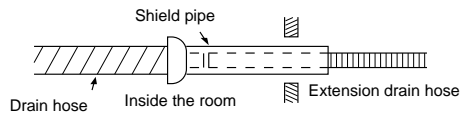

CAUTION

Install the drain pipe for proper drainage. Improper drainage can result in water dripping inside the room.

This air conditioner has been designed to drain water collected from condensation which forms on the back of the indoor unit, to the drain pan. Therefore, do not locate the power cord and other parts at a height above the drain guide.

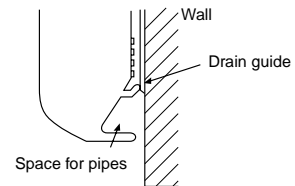

5 INSTALLATION OF OUTDOOR UNIT

Installation Location

- A place which provides enough space around the outdoor unit as shown in the diagram. (☞ see page 4.)
- A place which can bear the weight of the outdoor unit and does not allow an increase in noise level and vibration.
- A place where the operation noise and discharged air do not disturb neighbors.
- A place which is not exposed to a strong wind.
- A place free of combustible gases.
- A place which does not block a passageway.
- When the outdoor unit is to be installed in an elevated position, be sure to secure its feet.
- This air conditioner accepts a connection piping length from 2 m to 20 m.
 - There is no need to add refrigerant as long as the length of the connection piping is 15 m or less.
 - You will need to add 20 g of refrigerant per meter of added connection piping for installations requiring connection piping to be between 15 m to 20 m.
- An allowable height level is up to 10 m.
- A place where the drain water does not cause any problems.

Precautions for Adding Refrigerant

- Use a scale having at least 10 g per index line precision when adding the refrigerant. Do not use a bathroom scale or similar instrument.
- Use liquid refrigerant when refilling the refrigerant. Since the refrigerant is in liquid form, it can fill quickly. Therefore, perform the filling operation carefully and insert the refrigerant gradually.

Precautions about Installation in Regions with Snowfall and Cold Temperatures

- Do not use the supplied drain nipple for draining water. Drain the water from all the drain holes directly.
 - To protect the outdoor unit from snow accumulation, install a holding frame, and attach a snow protection hood and plate.
- * Do not use a double-stacked design.

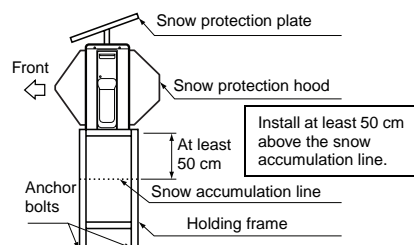

CAUTION

1. Install the outdoor unit in a location where there are no obstructions near its air intake or air outlet.
2. When the outdoor unit is installed in a place that is always exposed to strong winds like on the coast or on a high story of a building, secure the normal fan operation using a duct or a wind shield.
3. Especially in windy areas, install the unit to prevent the admission of wind.
4. Installation in the following places may result in trouble. Do not install the unit in such places.
 - A place full of machine oil.
 - A saline-place such as the coast.
 - A place full of sulfide gas.
 - A place where high-frequency waves are likely to be generated, such as from audio equipment, welders, and medical equipment.

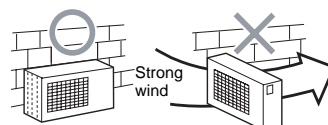

Draining the water

- Holes are provided on the base plate of the outdoor unit to ensure that the defrost water produced during heating operations is drained off efficiently. If a centralized drain is required when installing the unit on a balcony or wall, follow the steps below to drain off the water.
1. Proceed with water-proofing by installing the water-proof rubber caps ⑧ in the 2 elongated holes on the base plate of the outdoor unit.

[How to install the water-proof rubber caps]

 - 1) Place four fingers into each cap, and insert the caps into the water drain holes by pushing them into place from the underside of the base plate.
 - 2) Press down on the outer circumferences of the caps to ensure that they have been inserted tightly.
(Water leaks may result if the caps have not been inserted properly, if their outer circumferences lift up or the caps catch on or wedge against something.)

* When water still leaks even after performing steps 1) and 2), add caulking material, putty or other sealants.

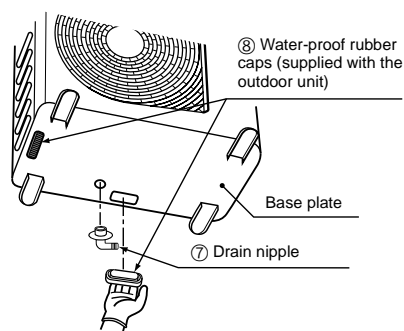

- Install the drain nipple ⑦ and a commercially available drain hose (with 16 mm inside diameter), and drain off the water.
(For the position where the drain nipple ⑦ is installed, refer to the installation diagram of the indoor and outdoor units.)
- Check that the outdoor unit is horizontal, and route the drain hose at a downward sloped angle with very little slack to the hose.

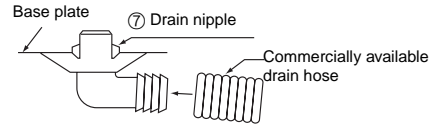

Do not use ordinary garden hose, which can flatten and prevent drainage.

Refrigerant Piping Connection

Flaring

- Cut the pipe with a pipe cutter.

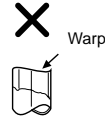
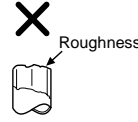
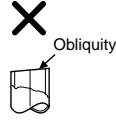
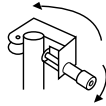

- Insert a flare nut into the pipe, and flare the pipe.
 - Projection margin in flaring: A (Unit: mm)

Rigid (Clutch type)

Outer diameter of copper pipe	R410A tool used	Conventional tool used
6.35	0 to 0.5	1.0 to 1.5
9.52	0 to 0.5	1.0 to 1.5
12.7	0 to 0.5	1.0 to 1.5

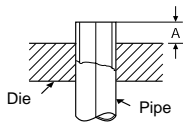

Imperial (Wing nut type)

Outer diameter of copper pipe	R410A
6.35	1.5 to 2.0
9.52	1.5 to 2.0
12.7	2.0 to 2.5

- Flaring size : B (Unit : mm)

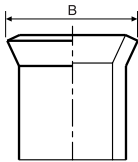

Outer diameter of copper pipe	B ⁺⁰ _{-0.4}	
	R410A	R22
6.35	9.1	9.0
9.52	13.2	13.0
12.7	16.6	16.2

- In case of flaring for R410A with the conventional flare tool, pull it out approx. 0.5 mm more than that of R22 to adjust the specified flare size. The copper pipe gauge is useful for adjusting projection margin size.

Tighten the connection

Align the centers of the connecting pipes and tighten the flare nut as much as possible with your fingers. Then tighten the nut with a wrench and torque wrench as shown in the figure.

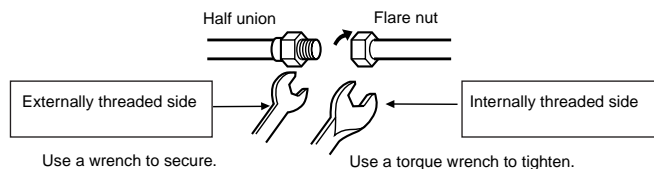

CAUTION

- Do not apply excessive force. Otherwise, the nut may break.

(Unit: N·m)

Outer diameter of copper pipe	Tightening torque
Dia. 6.35 mm	14 to 18 (1.4 to 1.8 kgf·m)
Dia. 9.52 mm	33 to 42 (3.3 to 4.2 kgf·m)
Dia. 12.7 mm	50 to 62 (5.0 to 6.2 kgf·m)

• **Tightening torque for connection of flare pipe**

The pressure of R410A is higher than R22. (Approx. 1.6 times.) Therefore securely tighten the flare pipes which connect the outdoor unit and the indoor unit with the specified tightening torque using a torque wrench.

If any flare pipe is incorrectly connected, it may cause not only a gas leakage but also trouble in the refrigeration cycle.

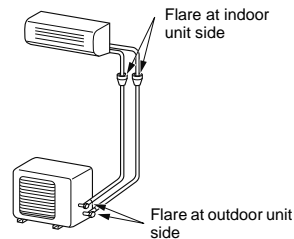

Evacuating

After the piping has been connected to the indoor unit, perform vacuuming.

AIR PURGE

Evacuate the air in the connecting pipes and in the indoor unit using a vacuum pump. Do not use the refrigerant in the outdoor unit. For details, see the vacuum pump manual.

Use a vacuum pump

Be sure to use a vacuum pump with counter-flow prevention function so that oil inside the pump does not flow back into the air conditioner pipes when the pump stops. (If oil inside the vacuum pump enters the air conditioner circuit which uses R410A, trouble with the refrigeration system may develop.)

1. Connect the charge hose from the manifold valve to the service port of the gas side packed valve.
2. Connect the charge hose to the port of the vacuum pump.
3. Open fully the low pressure side handle of the gauge manifold valve.
4. Operate the vacuum pump to begin evacuating. Perform evacuating for about 15 minutes if the piping length is 20 meters (15 minutes for 20 meters) (assuming a pump capacity of 27 liters per minute). Confirm that the compound pressure gauge reading is -101 kPa (-76 cmHg).
5. Close the low pressure valve handle of gauge manifold.
6. Open fully the valve stem of the packed valves (both sides of Gas and Liquid).
7. Remove the charging hose from the service port.
8. Securely tighten the caps on the packed valves.

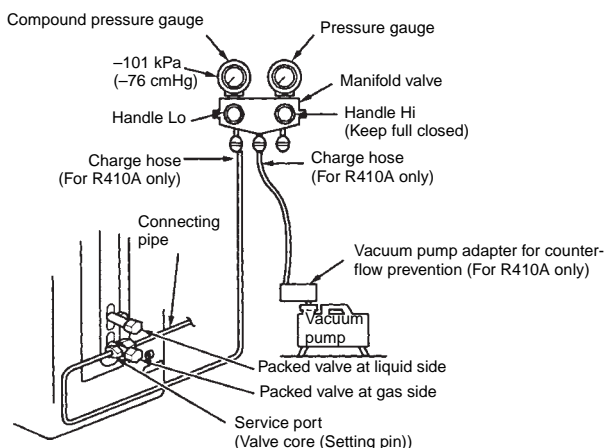

CAUTION

• **IMPORTANT POINTS FOR PIPING WORK**

- (1) Prevent dust and moisture from entering the pipes.
- (2) Tighten connections carefully (between pipes and unit).
- (3) Evacuate the air in the connecting pipes using a VACUUM PUMP.
- (4) Check for gas leaks at all connections.

Packed valve handling precautions

- Open the valve stem until it touches the stopper. Once it is in contact with the stopper, refrain from applying any more force than is necessary.
- Securely tighten the valve stem cap with torque in the following table:

Gas side (Dia. 12.7 mm)	33 to 42 N·m (3.3 to 4.2 kgf·m)
Gas side (Dia. 9.52 mm)	33 to 42 N·m (3.3 to 4.2 kgf·m)
Liquid side (Dia. 6.35 mm)	14 to 18 N·m (1.4 to 1.8 kgf·m)
Service port	14 to 18 N·m (1.4 to 1.8 kgf·m)

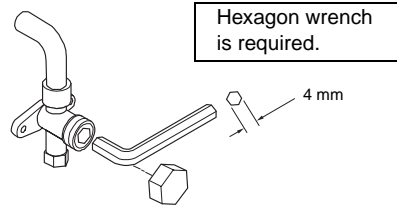

Wiring Connection

1. Remove the valve cover, the electric parts cover and the cord clamp from the outdoor unit.
2. Connect the connecting cable to the terminal as identified by the matching numbers on the terminal block of indoor and outdoor unit.
3. Insert the power cord and the connecting cable fully into the terminal block and secure it tightly with screws.
4. Use vinyl tape, etc. to insulate the cords which are not going to be used. Locate them so that they do not touch any electrical or metal parts.
5. Secure the power cord and the connecting cable with the cord clamp.
6. Attach the electric parts cover and the valve cover on the outdoor unit.

Stripping length of connecting cable

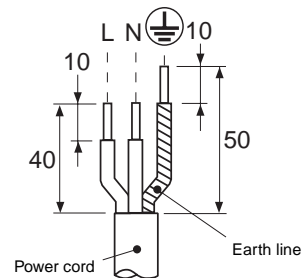
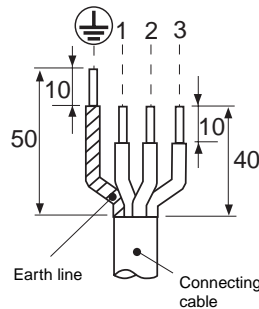
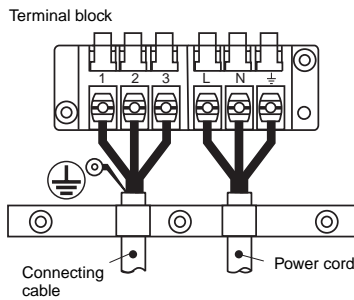

Model	RAS-07PKVP-E RAS-07PKVP-ND	RAS-10PKVP-E RAS-10PKVP-ND	RAS-13PKVP-E RAS-13PKVP-ND	RAS-16PKVP-E RAS-16PKVP-ND	RAS-18PKVP-E RAS-18PKVP-ND
Power source	220–240 V ~50 Hz 220–230 V ~60 Hz				
Maximum running current	9.5 A				
Installation fuse rating	16 A breaker or fuse (all types can be used)				
Power cord	H07RN-F or 60245IEC66 (1.5 mm ²)				
Connecting cable	Wire type: H07RN-F or 60245IEC66 (1.0 mm ²)				

CAUTION

- Incorrect wiring connection may cause electrical parts to burn out.
- Be sure to comply with local regulations/codes when running the wire from outdoor unit to indoor unit. (Size of wire and wiring method etc.)
- Every wire must be securely connected.
- If incorrect or incomplete wiring is carried out, fire or smoke may result.
- Prepare the power supply for the exclusive use of the air conditioner.

6 TEST OPERATION

Gas Leak Test

- Check the flare nut connections for gas leaks with a gas leak detector and/or soapy water.

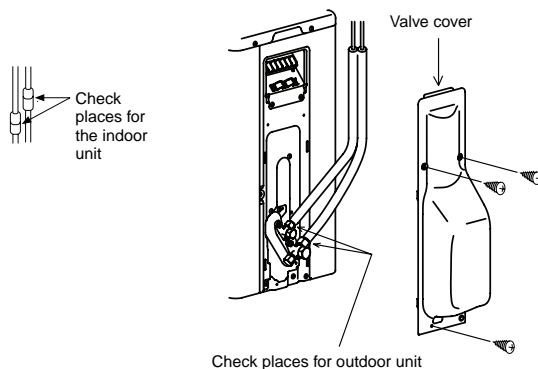

Test Operation

To test the system, press and hold RESET button for 10 sec.
(There will be one short beep.)

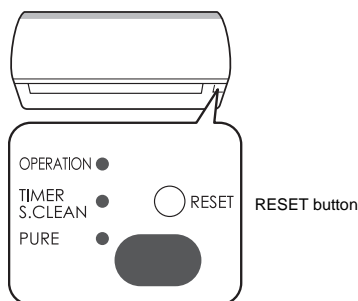

Auto Restart Setting

This product is designed so that, after a power failure, it can restart automatically in the same operating mode as before the power failure.

INFORMATION

The product was shipped with Auto Restart function in the OFF position. Turn it ON as required.

How to set the Auto Restart

- Press and hold the RESET button for about 3 seconds. After 3 seconds, three short electric beeps will be heard to inform you that the Auto Restart has been selected.
- To cancel the Auto Restart, follow the steps described in the section Auto Restart Function of the Owner's Manual.

If the air conditioner operates incorrectly

- If two indoor units are installed in the same room or adjoining rooms, when the user tries to operate only one unit, both units may receive the same remote controller signal and operate. This can be prevented by changing one of the indoor units and remote controllers to setting "B" (the default setting for both units is "A").
- If the indoor unit and remote controller settings are different, the remote controller signal is not accepted.

1. Setting the remote controller

- ① Slide open the remote controller cover and remove the batteries.
- ② Cut the jumper wire inside the battery compartment using nippers.
 - The jumper wire should not remain in contact after being cut. Also, be careful not to let plastic scraps, jumper wire cuttings or other debris enter the inside of the remote controller.
- ③ Insert the batteries. "B" appears in the remote controller display.

2. Setting the unit

Press the RESET button to start automatic operation.

3. Press the ⏻ button of the remote controller that was set in step 1 to stop the air conditioner. (This operation will change the setting to "B".)
4. Check that the remote controller operates the indoor unit.

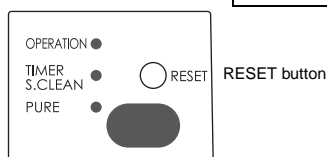
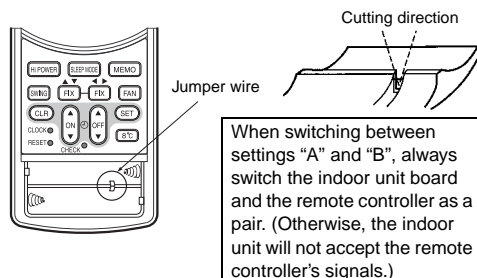

7 REMOVING THE MAIN PARTS

Normally, the front panel, moving panel, and air flow louvers do not need to be removed. However, use the procedure below if removal of these parts is necessary.

CAUTION

Before removing the front panel, moving panel, or air flow louvers, be sure to stop operation of the air conditioner and unplug the power supply.

Removing the front panel and moving panel

1. Open the moving panel, and support the moving panel by the panel support on the right side.

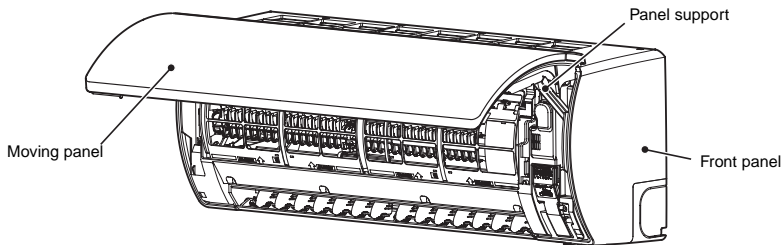

2. Remove the four set screws on the front panel.

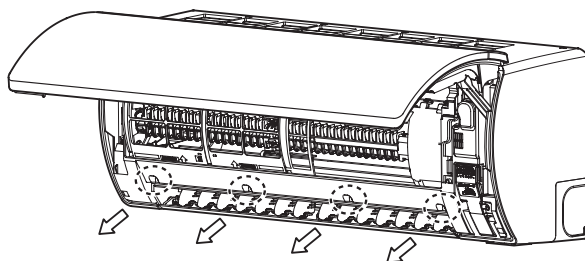

3. Insert your thumb into the air outlet bottom section, and lift up the front panel bottom.

4. Close the moving panel to remove the clips on the top side as shown below.

Press your finger down on the clip on the front panel top, and lift up the panel back edge so that the clip is released (5 locations).

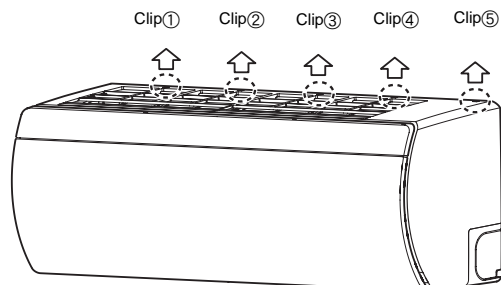

Removing the moving panel

1. Open the moving panel, and support the moving panel by the panel support on the right side.
2. Remove the lead wire cover on the right side. (1 screw)

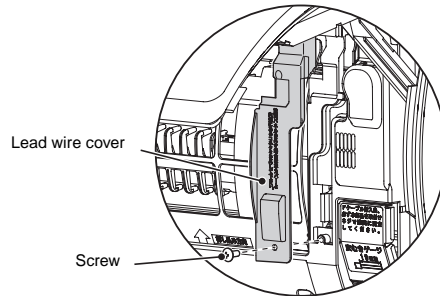

3. After removing a screw of the left-side panel stopper, slide the panel stopper downwards.

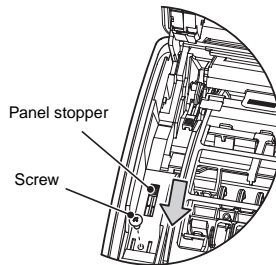

4. Grasp both sides of the moving panel, return the panel support to its original position, and press the left-side arm inwards with your finger.

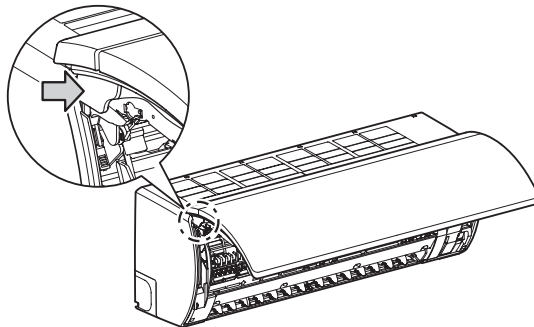

5. Pull out the moving panel towards the left side to remove.

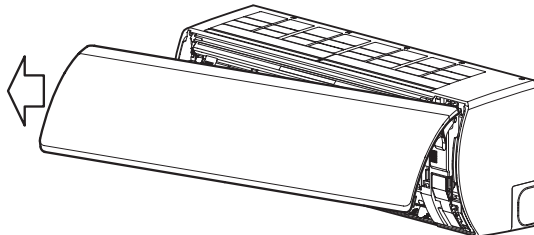

Attaching the moving panel

1. Grasp both sides of the moving panel, and insert the right-side joint first.

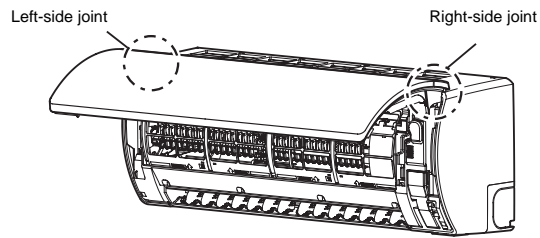

2. Insert the left-side joint, raise the panel stopper upwards, and secure with the screw.

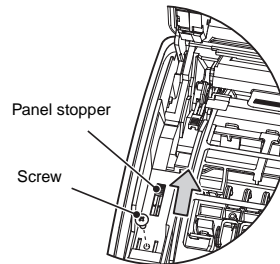

3. Insert the top edge of the lead wire cover into the front panel, and secure with a screw.

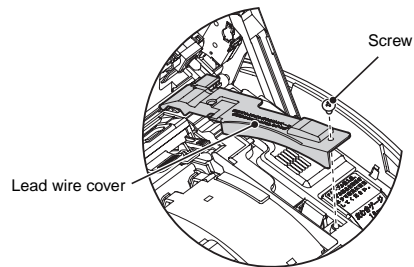

Removing the vertical air flow louver

CAUTION

The horizontal air flow louvers cannot be released from the vertical air flow louver.

1. Open the moving panel, and support it with the panel support.
2. Open the vertical air flow louver.
3. Insert a flathead screwdriver into the gap of the louver fixture on the right and left ends of the vertical air flow louver, and turn in the counter-clockwise direction to remove.

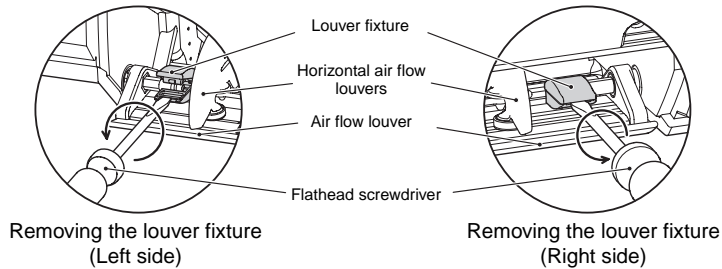

4. After pressing in the right and left connector joints, remove the vertical air flow louvers. Press in the right-side joint first before pressing in the left-side joint.

Attaching the vertical air flow louvers

1. Attach the vertical air flow louvers by inserting the connector joints in the order of left, right, and center.
2. Secure the horizontal air flow louvers to the connector joints.

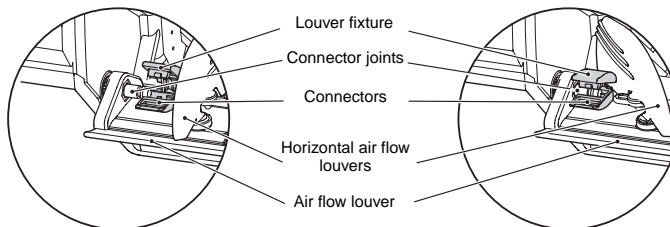

- After pressing in the connector joints, align the positions of the connector joints and connectors. Press the louver fixture downwards to lock it into place.
- After attaching, move the louver fixture from side to side to check that the connector joint does not come off.

TOSHIBA CARRIER CORPORATION