

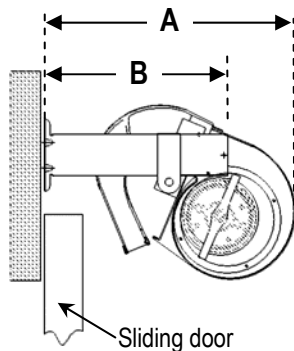

# TS Air Curtain Range (Cold Store) Installation, Operation and Maintenance Instructions

**PLEASE READ THESE INSTRUCTIONS CAREFULLY BEFORE  
INSTALLATION AND RETAIN FOR FUTURE REFERENCE**



**Figure 1: TS Cold Store Air Curtain Side View**

MODELS	TS42	TS54	TS40	TS60	TS66	TS78
A (min) (mm)	280	280	370	370	370	370
A (max) (mm)	460	460	500	500	500	500
B (mm)	305	305	305	305	305	305
C (mm)	1030	1330	1030	1510	1635	1835
Supply (50Hz)	230V~1P&N			400V~3P&N		
Current per Phase (A)	1.8	1.8	1.8	1.8	1.8	1.8
Weight (kg)	16	18	23	24	26	28
Max. Mounting Height (m)	2.75	2.75	3.30	3.30	3.30	3.30

Add 300mm to A and B if using extended wall brackets

**Table 1: TS Air Curtain Dimensional and Electrical Details**

## CONTENTS

Remove from carton and check contents include:

- TS air curtain
- 2 x Mounting brackets
- Door limit switch

## INSTALLATION

The TS air curtain is designed to be wall mounted horizontally above a door opening on the warm side i.e. external to the cold store. The mounting brackets provide space between the wall and the unit and allow the air discharge nozzle to be clear of the sliding door mechanism. The unit should be mounted as close to the door as possible ensuring the maximum mounting height is not exceeded (see Table 1). The door limit switch should be securely located, such that, opening the door will engage the switch.



**Figure 2: Coil Spring Rod Limit Switch**

- 1) Attach the two mounting brackets to the wall or fascia as shown below using 8mm Ø bolts or screws. The mounting holes are elongated to provide adjustment to ensure the brackets are square and parallel to each other.

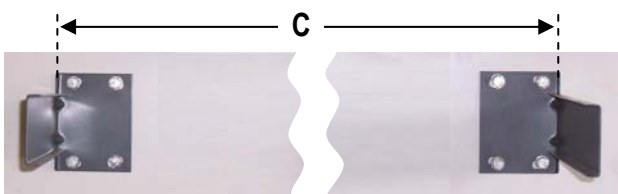

**Figure 3: Mounting Brackets Fixed to Wall or Fascia**

- 2) Slacken clamping bolts (See Figure 4) at each end of the TS air curtain. Slide both the unit suspension brackets onto the arms of the mounting brackets and push the unit back as far as possible. Ensure the air discharge nozzle does not interfere with the door opening and the air curtain is fitted as close to the slider door as possible. Tighten the clamping bolts.

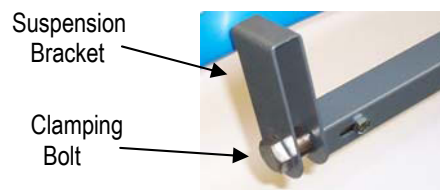

**Figure 4: Suspension Bracket and Clamping Bolt Assembly**

## ELECTRICAL INSTALLATION

All electrical wiring and connections must be carried out by a competent qualified electrician in accordance with the latest statutory edition of the IEE wiring regulations and/or local statutory regulations. A single phase or 3 phase local isolator with a contact separation of at least 3mm in all poles must be fitted to the supply wiring of each TS air curtain (the isolator must be fitted within an accessible position). Ensure that the supply cables, circuit breakers and other electrical installation equipment are correctly sized for the air curtain being installed (see Table 1).

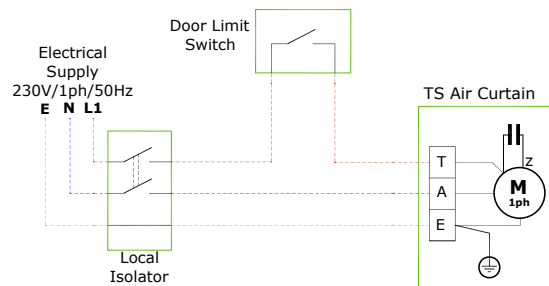

**Figure 5: Standard Single Phase Wiring Diagram**

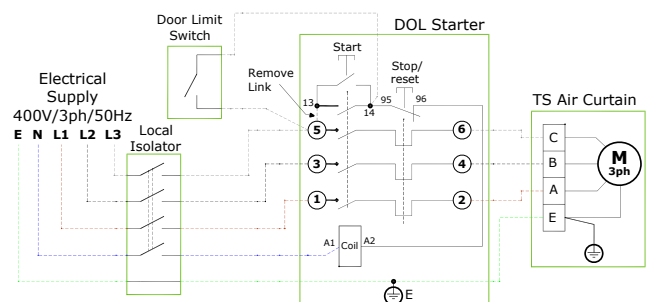

**Figure 6: Suggested Three Phase Wiring Diagram**

Recommended electrical connection for TS range of air curtains should be carried out as per Figure 5 (single phase) and Figure 6 (three phase).

For three phase TS air curtain models ensure the DOL Starter (supplied by others) is connected as shown in Figure 6. Note: for this configuration the start button on the DOL Starter is not functional and the unit is controlled by the door limit switch.

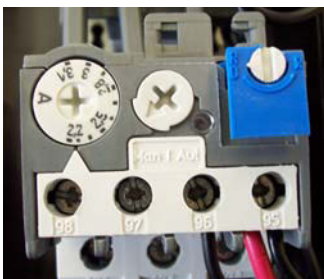

**Figure 7: DOL Starter Overload Relay Settings (not supplied)**

Adjust the DOL overload relay settings as shown in Figure 7 above; set current calibration dial to 2.2A the Man/Aut switch to manual mode. If the overload trips-out in manual mode, the reset button will be required to be pressed before starting the air curtain.

### DISCHARGE JET ADJUSTMENT

If the ambient air from the discharge jet hits the floor close to the opening to the cold area, mixing of ambient and cold air can occur, and this may result in misting. To ensure that this is avoided both the discharge angle and velocity may be adjusted.

### ANGLE ADJUSTMENT

- 1) Loosen lock nut
- 2) Rotate knob (anti-clockwise to increase angle between discharge jet and the vertical) until desired angle is achieved (30° is usually appropriate)

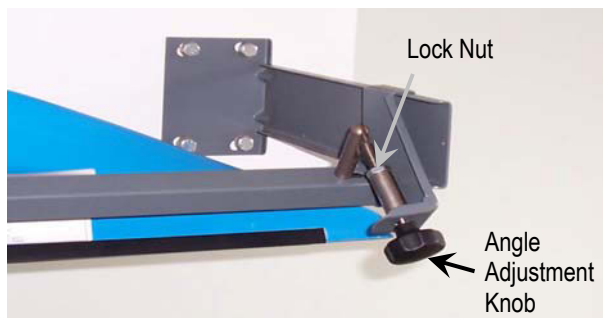
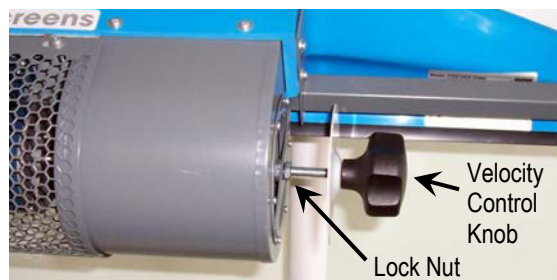

**Figure 8: Discharge Nozzle Angle Adjustment**

### VELOCITY ADJUSTMENT

The discharge velocity can be adjusted by controlling the air intake at the sides of both the fans.

- 1) Loosen lock nut
- 2) Rotate velocity control knob until disc is at the desired position (Figure 9 details fully open – maximum velocity)
- 3) Tighten lock nut
- 4) Repeat for left-hand fan



**Figure 9: Discharge Air Velocity Control Knob**

The optimum angle in most applications is ~30° to the vertical as shown below. The required velocity will depend on the mounting height and other considerations, e.g. objects which could be blown from a conveyor, and should be determined at installation.

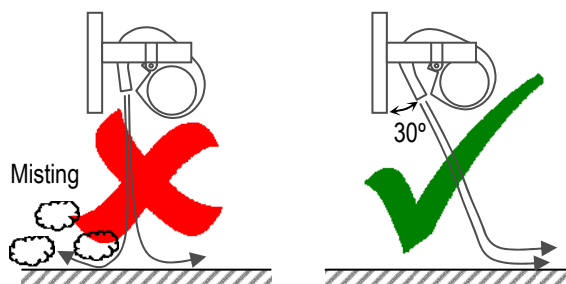

**Figure 10: Air Discharge Outlet Angle**

### SERVICE & MAINTENANCE

Always disconnect and isolate the mains electricity supply before installing, maintaining or repairing this equipment. Note: All maintenance/repairs should only be carried out by a competent electrician or Thermoscreens appointed technician.

To ensure the air curtain operates at full efficiency the inlet grille, fan impellers, housings and motors must be kept free of dust and debris. Build up of dust on the fan impellers can cause vibration, noise and excessive wear on the motor bearings. Vacuum and clean the build-up of dirt and debris within the unit.

If the outer casing requires cleaning this should be done using a warm soft cloth. Do not use solvents or abrasive materials.

Please note that the motor is permanently lubricated and requires no additional lubrication.

Once the air curtain has been cleaned check all electrical connections within the unit ensuring terminals are tight and that crimped connections have not become loose.

Reconnect the electrical supply and fully function test the air-curtain to ensure correct operation.

### WARRANTY

If any problems are encountered, please contact your installer/supplier. Failing this please contact the Thermoscreens warranty department. All units are covered by a two year warranty period.

Care has been taken in compiling these instructions to ensure they are correct, although Thermoscreens disclaims all liability for damage resulting from any inaccuracies and/or deficiencies in this documentation. Thermoscreens retain the right to change the specifications stated in these instructions.

