

INDOOR UNIT

1. WALL MOUNTED TYPE :

AS * A07LCC

AS * A09LCC

AS * A12LCC

AS * A14LCC

AS * A18LCC

1. FEATURE

■ MODEL :

AS*A07LCC
AS*A09LCC
AS*A12LCC
AS*A14LCC
AS*A18LCC



■ FEATURES

- Energy saving Rank A (07/09/12/14TYPE)
Europe energy saving Rank A achieved

- ALL DC (14/18TYPE)

ALL
DC

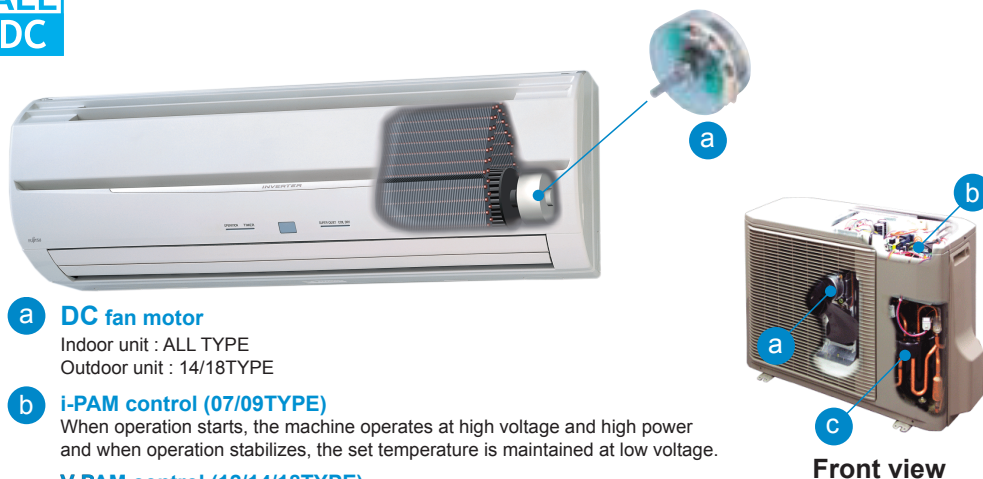

a DC fan motor

Indoor unit : ALL TYPE
Outdoor unit : 14/18TYPE

b i-PAM control (07/09TYPE)

When operation starts, the machine operates at high voltage and high power and when operation stabilizes, the set temperature is maintained at low voltage.

V-PAM control (12/14/18TYPE)

V-PAM technology makes a compressor more powerful.

c DC rotary compressor

Front view

- Super quiet

Air flow mode can be set in 4 steps and more detailed air flow setting is possible.

- Easy maintenance

Easy maintenance and always clean. Troublesome maintenance has been made easy.

Since the front panel is easy to remove, maintenance is also easy.



● Inner drying operation

This model is equipped with an inner drying function. After the power is turned off, the dry operation starts inside the air conditioner. This prevents the growth of mold and bacteria inside the air conditioner.

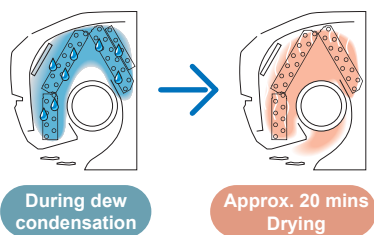

● Low outdoor air temperature cooling correspondence (14, 18TYPE)

Corresponds to cooling operation at -10°C outdoor air temperature

● Corresponds to maximum 20m long piping

● Air conditioner filter features



2. REMOTE CONTROLLER

2-1. WIRELESS REMOTE CONTROLLER

■ FEATURES



* Four kinds of timer setup (ON / OFF / PROGRAM / SLEEP) are possible.

* Four kinds of timers. Easy operation.

● Built-in timers

Select from four different timer programs (On/Off/Program/Sleep).

● Program timer

The program timer operates the ON and OFF timer once within a 24 hour period.

● Sleep timer

The sleep timer function automatically corrects the temperature thermostat setting according to the time setting to prevent excessive cooling and heating while sleeping.

Cooling operation/dry operation

When the sleep timer is set, the set temperature automatically rises 1°C every hour. The set temperature can rise up to a maximum of 2°C .

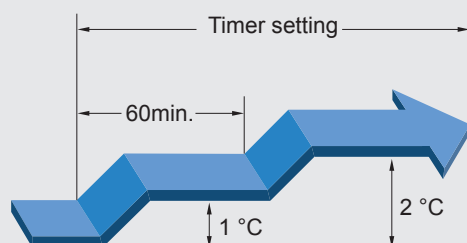

Heating operation

When the sleep timer is set, the set temperature automatically drops 1°C every 30 minutes. The set temperature can drop to a maximum of 4°C .

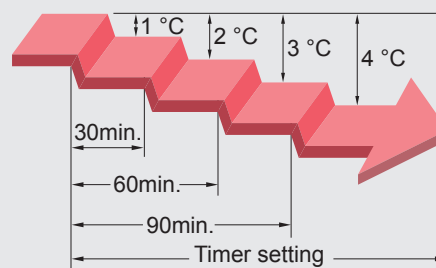

FUNCTIONS

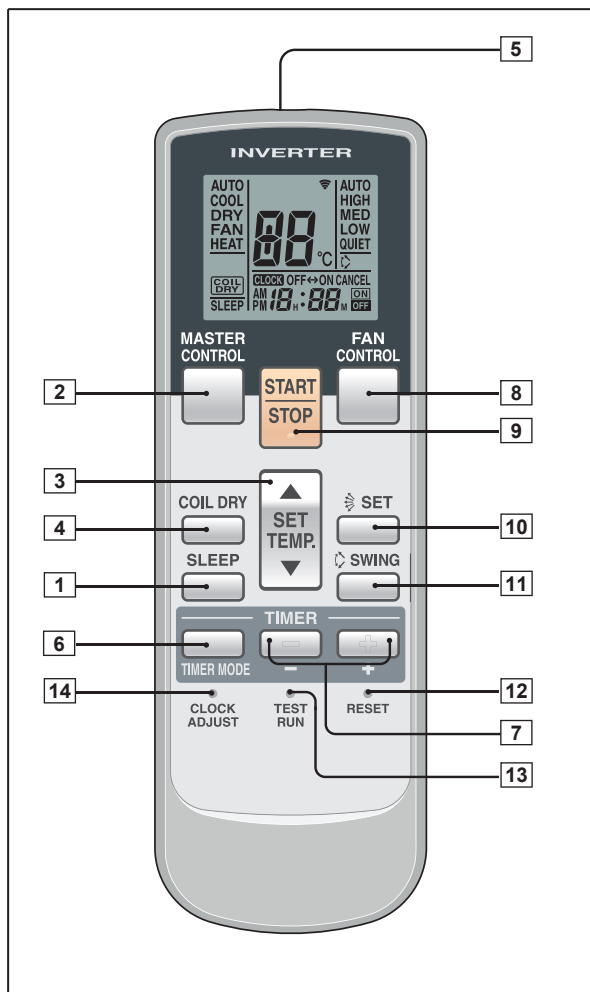

- 1 SLEEP button
- 2 MASTER CONTROL button
- 3 SET TEMP button (▲ / ▼)
- 4 COIL DRY button
- 5 Signal Transmitter
- 6 TIMER MODE button
- 7 TIMER SET (+ / -) button
- 8 FAN CONTROL button
- 9 START/STOP button
- 10 SET button (Vertical)
- 11 SWING button
- 12 RESET button
- 13 TEST RUN button
 - This button is used when installing the conditioner, and should not be used under normal conditions, as it will cause the air conditioner's thermostat function to operate incorrectly.
 - If this button is pressed during normal operation, the unit will switch to test operation mode, and the Indoor Unit's OPERATION Indicator Lamp and TIMER Indicator Lamp will begin to flash simultaneously.
 - To stop the test operation mode, press the START/STOP button to stop the air conditioner.
- 14 CLOCK ADJUST button

Display panel

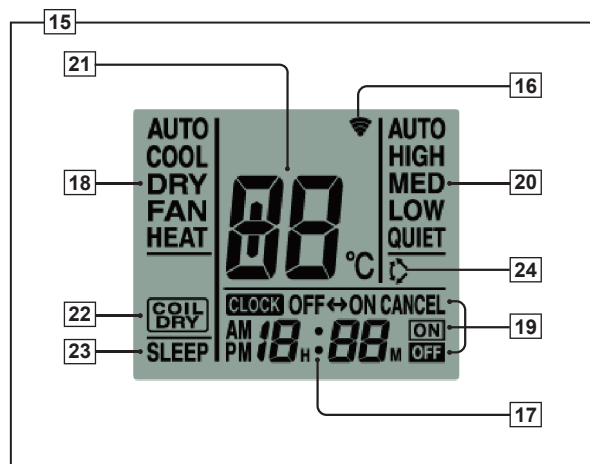

- 15 Remote Control Unit Display
- 16 Transmit Indicator
- 17 Clock Display
- 18 Operating Mode Display
- 19 Timer Mode Display
- 20 Fan Speed Display
- 21 Temperature SET Display
- 22 COIL DRY Display
- 23 SLEEP Display
- 24 SWING Display

SPECIFICATION

SIZE (H x W x D mm)	176 x 56 x 18
WEIGHT (g)	110
ACCESSORY	Holder

3. SPECIFICATIONS

Type				WALL MOUNTED			
				INVERTER HEAT PUMP			
Model name				AS * A07LCC	AS * A09LCC	AS * A12LCC	
Power source				230V~ 50Hz			
Available voltage range				198 - 264V~ 50Hz			
European energy label			Cooling	A	A	A	
			Heating	A	A	A	
Capacity	Cooling	Rated	kW	2.10	2.60	3.50	
			BTU/h	7,200	8,900	11,900	
		Min-Max	kW	0.5 - 3.0	0.5 - 3.6	0.9 - 4.3	
	BTU/h		1,700 - 10,200	1,700 - 12,300	3,100 - 14,700		
	Heating	Rated	kW	3.00	3.60	4.80	
			BTU/h	10,200	12,300	16,400	
Min-Max		kW	0.5 - 4.6	0.5 - 5.3	0.9 - 6.7		
	BTU/h	1,700 - 15,700	1,700 - 18,100	3,100 - 22,900			
Input power	Cooling	Rated	kW	0.47	0.655	0.92	
				Min-Max	0.25 - 1.08	0.25 - 1.18	0.25 - 1.61
	Heating	Rated	0.66	0.845	1.24		
			Min-Max	0.25 - 1.76	0.25 - 1.96	0.25 - 2.30	
Current	Cooling	Rated	A	2.5	3.2	4.3	
				Max	6.0	6.0	7.0
	Heating	Rated	3.2	4.0	5.6		
			Max	8.5	8.5	10.0	
EER		Cooling	kW/kW	4.47	3.97	3.80	
COP		Heating		4.55	4.26	3.87	
SENSIBLE CAPACITY		Cooling	kW	1.40	1.70	2.30	
POWER FACTOR		Cooling	%	82	90	93	
		Heating		90	91	96	
Moisture removal			l/h (pints/h)	1.0 (2.1)	1.3 (2.7)	1.8 (3.8)	
Fan	Airflow rate	Cooling	High	m ³ /h	595	635	
			Med		500	515	
			Low		410	410	
		Quiet	290		290		
		Heating	High		645	670	
			Med		540	540	
	Low		435	435			
		Quiet	320	320			
	Type × Q'ty			Cross flow fan × 1			
	Motor output			W	24	24	24
Noise level	Cooling	High	dB(A)	41	41	42	
				Med	36	36	36
				Low	30	30	30
				Quiet	21	21	21
	Heating	High	41	41	42		
			Med	36	36	35	
			Low	30	30	29	
			Quiet	21	21	21	
Heat exchanger type		Dimensions (H × W × D)	mm	336 × 635 × 26.6			
		Fin pitch		1.2			
		Rows x Stages		2 × 16			
		Pipe type		Copper			
Enclosure		Material		Polystyrene			
		Colour		White			
Dimensions (H × W × D)	Net		mm	275 × 790 × 215			
	Gross			290 × 835 × 345			
Weight	Net		kg (lb.)	9 (20)			
	Gross			12 (17)			
Connection pipe	Size	Liquid	mm	Φ 6.35 (Φ 1/4 in.)			
		Gas		Φ 9.52 (Φ 3/8 in.)			
	Method				Flare		
Operation range		Cooling	°C	18 to 32			
			%RH	80 or less			
Remote controller type		Heating	°C	30 or less			
					Wireless		
Drain pipe	Material		PVC				
	Size		mm	Outer diameter : 28 / Inner diameter : 16			

Note :

Specifications are based on the following conditions.

Cooling : Indoor temperature of 27°CDB/19°CWB, and outdoor temperature of 35°CDB/24°CWB.

Heating : Indoor temperature of 20°CDB/15°CWB, and outdoor temperature of 7°CDB/6°CWB.

Pipe length : 7.5 m, Height difference : 0 m. (Outdoor unit - Indoor unit)

Type			WALL MOUNTED			
			INVERTER HEAT PUMP			
Model name			AS*A14LCC	AS*A18LCC		
Power source			230V~ 50Hz			
Available voltage range			198 - 264V~ 50Hz			
European energy label			Cooling	A	B	
			Heating	A	A	
Capacity	Cooling	Rated	kW	4.20	5.20	
			BTU/h	14,300	17,700	
		Min-Max	kW	0.9 - 5.3	0.9 - 5.7	
			BTU/h	3,100 - 18,100	3,100 - 19,400	
	Heating	Rated	kW	5.60	6.25	
			BTU/h	19,100	21,300	
Min-Max		kW	0.9 - 8.4	0.9 - 9.1		
		BTU/h	3,100 - 28,700	3,100 - 31,000		
Input power	Cooling	kW	Rated	1.11	1.72	
			Min-Max	0.09 - 1.75	0.09 - 2.00	
	Heating		Rated	1.45	1.73	
			Min-Max	0.09 - 2.48	0.09 - 2.66	
Current	Cooling	A	Rated	5.0	7.6	
			Max	9.0	9.0	
	Heating		Rated	6.4	7.7	
			Max	13.5	13.5	
EER			Cooling	kW/kW	3.78	3.02
COP			Heating	kW/kW	3.86	3.61
SENSIBLE CAPACITY			Cooling	kW	2.80	3.30
POWER FACTOR			Cooling	%	96	98
			Heating	%	98	98
Moisture removal			l/h (pints/h)	2.1 (4.4)	2.8 (5.9)	
Fan	Airflow rate	Cooling	High	700		
			Med	580		
			Low	460		
			Quiet	370		
		Heating	High	700		
			Med	600		
			Low	500		
			Quiet	420		
	Type × Q'ty			Cross flow fan × 1		
	Motor output			W	24	24
Noise level	Cooling	dB(A)	High	44	44	
			Med	38	38	
			Low	32	32	
			Quiet	25	25	
	Heating		High	43	42	
			Med	37	37	
			Low	32	32	
			Quiet	27	27	
Heat exchanger type			Dimensions (H × W × D)	MAIN : 336 × 635 × 26.6 SUB : 84 × 635 × 13.3		
				Fin pitch	Main : 1.2, Sub : 1.4	
			Rows × Stages	Main : 2 × 16, Sub : 1 × 4		
			Pipe type	Copper		
			Fin type	Aluminium		
Enclosure			Material	Polystyrene		
			Colour	White		
Dimensions (H × W × D)	Net		mm	275 × 790 × 215		
	Gross			290 × 835 × 345		
Weight	Net		kg(lb.)	9 (20)		
	Gross			12 (26)		
Connection pipe	Size	Liquid	mm	Φ6.35 (Φ1/4 in.)		
		Gas		Φ12.7 (Φ1/2 in.)		
	Method			Flare		
Operation range			Cooling	°C	18 to 32	
			Heating	%RH	80 or less	
				°C	30 or less	
Remote controller type			Wireless			
Drain pipe	Material			PVC		
	Size			mm		Outer diameter : 28 / Inner diameter : 16

Note :
 Specifications are based on the following conditions.
 Cooling : Indoor temperature of 27°CDB/19°CWB. and outdoor temperature of 35°CDB/24°CWB.
 Heating : Indoor temperature of 20°CDB/15°CWB. and outdoor temperature of 7°CDB/6°CWB.
 Pipe length : 7.5 m, Height difference : 0 m. (Outdoor unit - Indoor unit)

4. DIMENSIONS

■ MODEL : AS*A07LC, AS*A09LC, AS*A12LC, AS*A14LC, AS*A18LC

(Unit : mm)

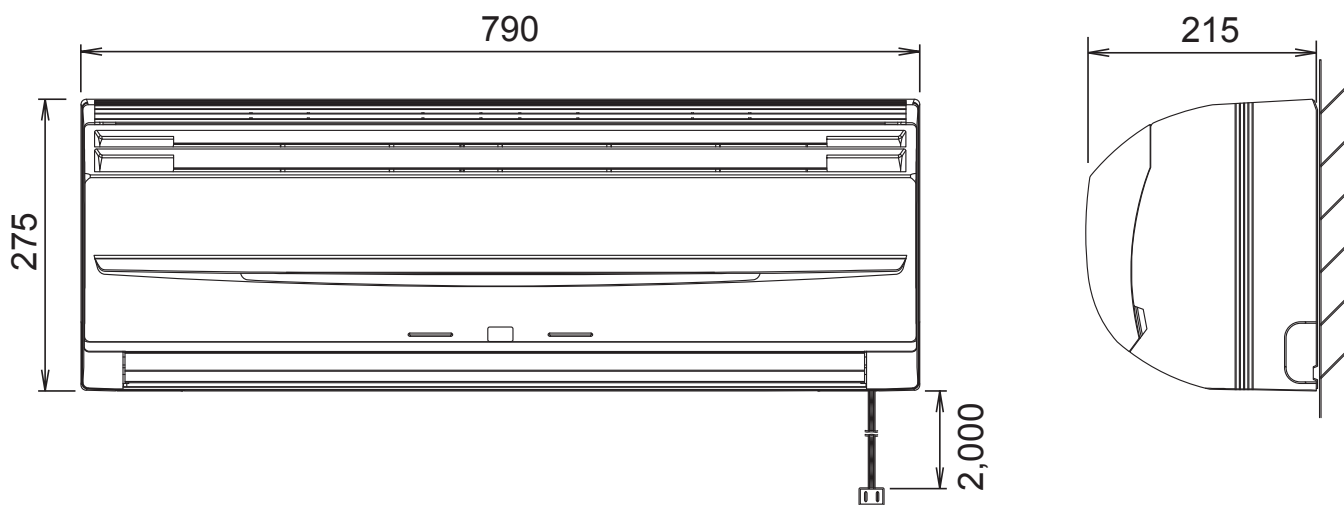

■ INSTALLATION PLACE

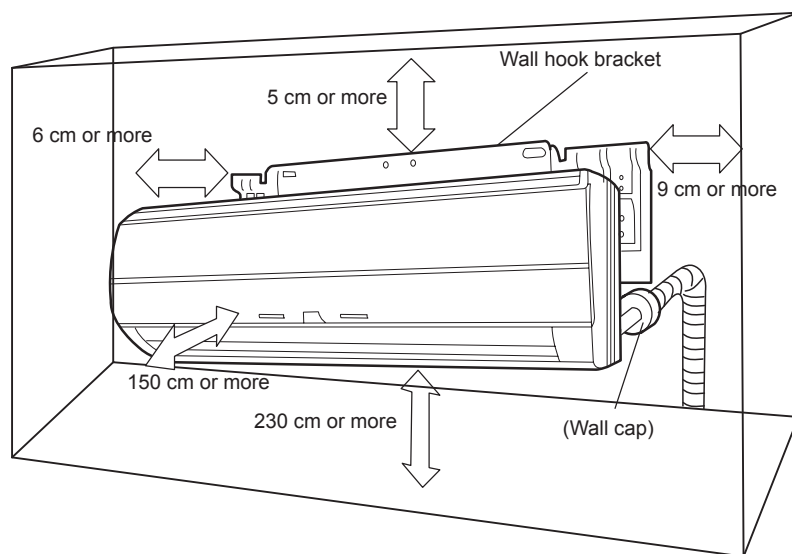

5. WIRING DIAGRAMS

■ MODEL : AS*A07LC, AS*A09LC, AS*A12LC, AS*A14LC, AS*A18LC

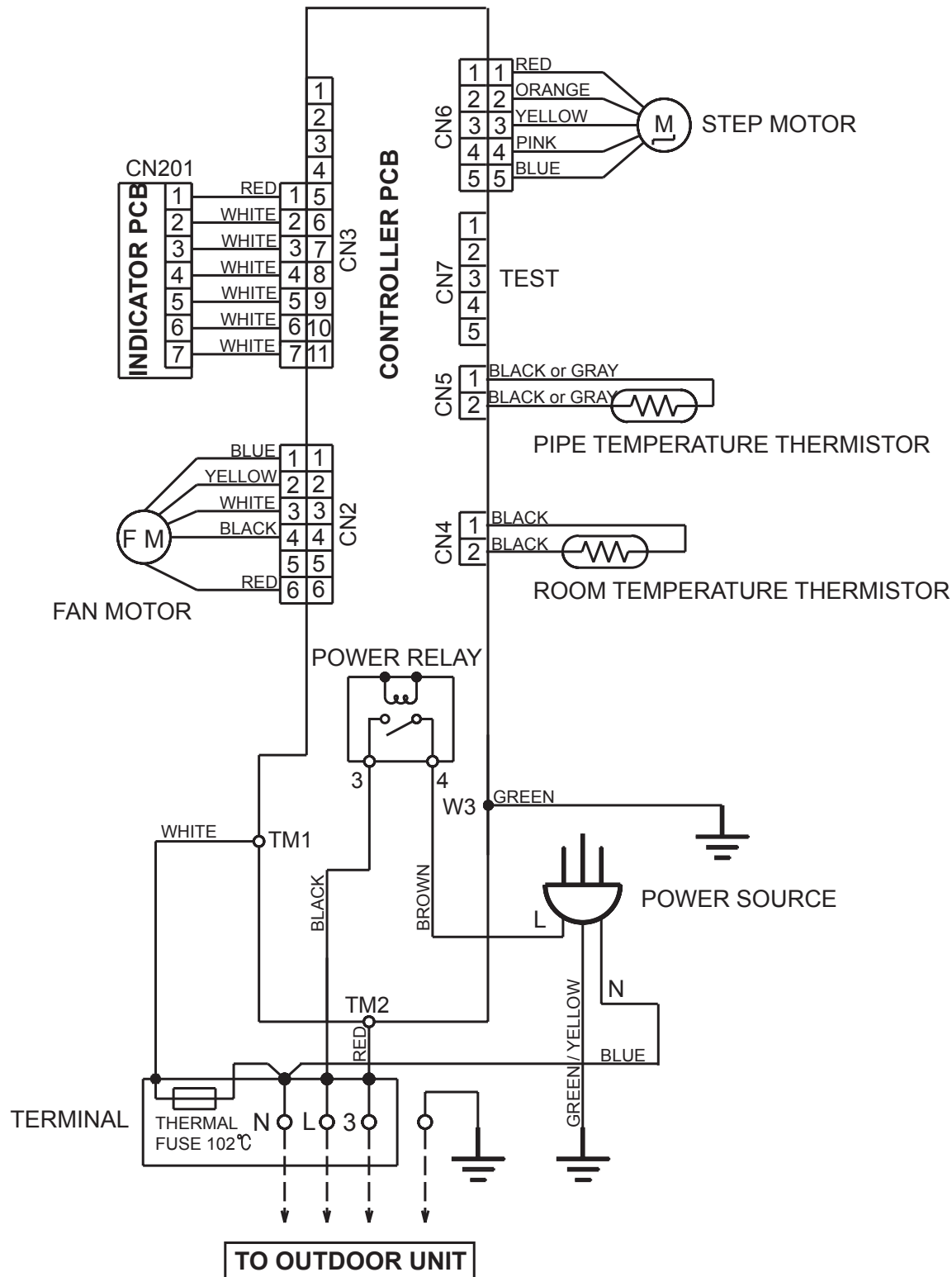

6. CAPACITY TABLE

6-1. COOLING CAPACITY

■ MODEL : AS *A07LC

AFR	9.9
-----	-----

		Indoor temperature																					
		18			21			23			25			27			29			32			
		°CDB			°CWB			°CDB			°CWB			°CDB			°CWB			°CDB			°CWB
Outdoor temperature	°CDB	TC	SHC	PI	TC	SHC	PI	TC	SHC	PI	TC	SHC	PI	TC	SHC	PI	TC	SHC	PI	TC	SHC	PI	
	20	1.56	1.11	0.22	1.73	1.11	0.23	1.79	1.21	0.23	1.91	1.22	0.23	1.97	1.31	0.23	2.09	1.31	0.23	2.20	1.39	0.24	
	25	1.85	1.32	0.37	2.06	1.33	0.38	2.13	1.44	0.38	2.28	1.45	0.38	2.35	1.56	0.39	2.49	1.56	0.39	2.63	1.66	0.39	
	30	1.77	1.26	0.41	1.98	1.27	0.42	2.04	1.38	0.42	2.18	1.39	0.43	2.25	1.50	0.43	2.38	1.49	0.43	2.51	1.59	0.44	
	35	1.66	1.18	0.45	1.85	1.19	0.46	1.91	1.29	0.46	2.04	1.30	0.47	2.10	1.40	0.47	2.23	1.39	0.47	2.35	1.49	0.48	
	40	1.50	1.07	0.46	1.67	1.07	0.46	1.72	1.17	0.47	1.84	1.17	0.47	1.90	1.26	0.47	2.01	1.26	0.48	2.12	1.34	0.48	
	43	1.40	1.00	0.46	1.56	1.00	0.47	1.61	1.09	0.47	1.72	1.09	0.47	1.77	1.18	0.48	1.88	1.18	0.48	1.98	1.25	0.49	

■ MODEL : AS *A09LC

AFR	9.9
-----	-----

		Indoor temperature																					
		18			21			23			25			27			29			32			
		°CDB			°CWB			°CDB			°CWB			°CDB			°CWB			°CDB			°CWB
Outdoor temperature	°CDB	TC	SHC	PI	TC	SHC	PI	TC	SHC	PI	TC	SHC	PI	TC	SHC	PI	TC	SHC	PI	TC	SHC	PI	
	20	1.93	1.34	0.31	2.14	1.35	0.32	2.22	1.47	0.32	2.36	1.48	0.32	2.44	1.59	0.32	2.58	1.59	0.33	2.73	1.69	0.33	
	25	2.29	1.60	0.52	2.56	1.61	0.53	2.64	1.75	0.53	2.82	1.76	0.53	2.90	1.90	0.54	3.08	1.89	0.54	3.25	2.01	0.55	
	30	2.20	1.53	0.57	2.45	1.54	0.58	2.53	1.68	0.59	2.70	1.68	0.59	2.78	1.82	0.60	2.95	1.81	0.60	3.11	1.93	0.61	
	35	2.05	1.43	0.63	2.29	1.44	0.64	2.37	1.57	0.65	2.52	1.57	0.65	2.60	1.70	0.66	2.76	1.69	0.66	2.91	1.80	0.67	
	40	1.85	1.30	0.64	2.07	1.30	0.65	2.14	1.42	0.65	2.28	1.42	0.66	2.35	1.53	0.66	2.49	1.53	0.67	2.63	1.63	0.67	
	43	1.73	1.21	0.64	1.93	1.22	0.65	2.00	1.32	0.65	2.13	1.33	0.66	2.19	1.43	0.66	2.33	1.43	0.67	2.46	1.52	0.68	

■ MODEL : AS *A12LC

AFR	10.6
-----	------

		Indoor temperature																					
		18			21			23			25			27			29			32			
		°CDB			°CWB			°CDB			°CWB			°CDB			°CWB			°CDB			°CWB
Outdoor temperature	°CDB	TC	SHC	PI	TC	SHC	PI	TC	SHC	PI	TC	SHC	PI	TC	SHC	PI	TC	SHC	PI	TC	SHC	PI	
	20	2.59	1.82	0.44	2.89	1.83	0.45	2.99	1.99	0.45	3.18	2.00	0.45	3.28	2.16	0.45	3.48	2.15	0.46	3.67	2.29	0.46	
	25	3.09	2.17	0.73	3.44	2.18	0.74	3.56	2.37	0.74	3.79	2.38	0.75	3.91	2.57	0.75	4.14	2.56	0.76	4.38	2.73	0.77	
	30	2.96	2.08	0.81	3.29	2.09	0.82	3.41	2.27	0.82	3.63	2.28	0.83	3.74	2.46	0.84	3.97	2.45	0.84	4.19	2.61	0.85	
	35	2.77	1.94	0.89	3.08	1.95	0.90	3.19	2.12	0.91	3.40	2.13	0.92	3.50	2.30	0.92	3.71	2.29	0.93	3.92	2.44	0.94	
	40	2.50	1.75	0.89	2.78	1.76	0.91	2.87	1.92	0.91	3.06	1.92	0.92	3.16	2.08	0.93	3.35	2.07	0.93	3.54	2.20	0.94	
	43	2.33	1.64	0.90	2.60	1.65	0.91	2.69	1.79	0.92	2.86	1.80	0.93	2.95	1.94	0.93	3.13	1.93	0.94	3.31	2.06	0.95	

AFR : Air Flow Rate (m³/min)
 TC : Total Capacity (kW)
 SHC : Sensible Heat Capacity (kW)
 PI : Power Input (kW)

MODEL : AS*A14LC

AFR 11.7

Outdoor temperature	Indoor temperature																							
	°CDB	18			21			23			25			27			29			32				
	°CWE	12			15			16			18			19			21			23				
	°CDB	TC	SHC	PI	TC	SHC	PI	TC	SHC	PI	TC	SHC	PI	TC	SHC	PI	TC	SHC	PI	TC	SHC	PI		
20	3.11	2.22	0.53	3.46	2.23	0.54	3.58	2.42	0.54	3.82	2.43	0.55	3.94	2.62	0.55	4.17	2.61	0.55	4.41	2.78	0.56			
25	3.71	2.64	0.88	4.13	2.66	0.89	4.27	2.89	0.90	4.55	2.90	0.91	4.69	3.13	0.91	4.97	3.11	0.92	5.25	3.32	0.93			
30	3.55	2.53	0.97	3.95	2.54	0.99	4.09	2.76	0.99	4.36	2.77	1.00	4.49	2.99	1.01	4.76	2.98	1.02	5.03	3.18	1.03			
35	3.32	2.36	1.07	3.70	2.38	1.09	3.82	2.58	1.09	4.07	2.59	1.10	4.20	2.80	1.11	4.45	2.79	1.12	4.70	2.97	1.13			
40	2.99	2.13	1.08	3.34	2.15	1.09	3.45	2.33	1.10	3.68	2.34	1.11	3.79	2.53	1.12	4.02	2.52	1.13	4.25	2.68	1.14			
43	2.80	1.99	1.09	3.12	2.01	1.10	3.22	2.18	1.11	3.44	2.19	1.12	3.54	2.36	1.13	3.76	2.35	1.14	3.97	2.51	1.15			

MODEL : AS*A18LC

AFR 11.7

Outdoor temperature	Indoor temperature																							
	°CDB	18			21			23			25			27			29			32				
	°CWE	12			15			16			18			19			21			23				
	°CDB	TC	SHC	PI	TC	SHC	PI	TC	SHC	PI	TC	SHC	PI	TC	SHC	PI	TC	SHC	PI	TC	SHC	PI		
20	3.85	2.61	0.82	4.29	2.63	0.83	4.44	2.86	0.84	4.73	2.86	0.84	4.87	3.09	0.85	5.17	3.08	0.86	5.46	3.28	0.87			
25	4.59	3.11	1.36	5.11	3.13	1.38	5.29	3.40	1.39	5.63	3.41	1.40	5.81	3.69	1.41	6.16	3.67	1.43	6.51	3.91	1.44			
30	4.39	2.98	1.51	4.89	3.00	1.53	5.06	3.26	1.54	5.39	3.27	1.56	5.56	3.53	1.56	5.89	3.51	1.58	6.23	3.74	1.59			
35	4.11	2.79	1.66	4.58	2.80	1.69	4.73	3.05	1.69	5.04	3.06	1.71	5.20	3.30	1.72	5.51	3.29	1.74	5.82	3.50	1.75			
40	3.71	2.51	1.67	4.13	2.53	1.70	4.27	2.75	1.70	4.55	2.76	1.72	4.69	2.98	1.73	4.98	2.97	1.75	5.26	3.16	1.77			
43	3.47	2.35	1.68	3.86	2.36	1.71	3.99	2.57	1.72	4.26	2.58	1.74	4.39	2.78	1.75	4.65	2.77	1.76	4.91	2.95	1.78			

AFR : Air Flow Rate (m³/min)
 TC : Total Capacity (kW)
 SHC : Sensible Heat Capacity (kW)
 PI : Power Input (kW)

6-2. HEATING CAPACITY

■ MODEL : AS *A07LC

AFR	9.9
-----	-----

		Indoor temperature										
		°CDB	16		18		20		22		24	
Outdoor temperature	°CDB	°CWB	TC	PI	TC	PI	TC	PI	TC	PI	TC	PI
	-15	-16	2.57	1.33	2.51	1.36	2.45	1.38	2.39	1.41	2.33	1.44
	-10	-11	3.05	1.45	2.98	1.48	2.91	1.51	2.84	1.54	2.76	1.57
	-5	-7	3.44	1.53	3.36	1.56	3.27	1.59	3.19	1.62	3.11	1.65
	0	-2	3.97	1.63	3.88	1.66	3.78	1.70	3.69	1.73	3.59	1.77
	5	3	4.52	1.74	4.41	1.78	4.30	1.81	4.19	1.85	4.09	1.89
	7	6	4.83	1.69	4.72	1.72	4.60	1.76	4.49	1.80	4.37	1.83
	10	8	5.00	1.69	4.88	1.73	4.77	1.76	4.65	1.80	4.53	1.83
15	10	4.84	1.47	4.73	1.50	4.61	1.53	4.50	1.56	4.38	1.59	

■ MODEL : AS *A09LC

AFR	9.9
-----	-----

		Indoor temperature										
		°CDB	16		18		20		22		24	
Outdoor temperature	°CDB	°CWB	TC	PI	TC	PI	TC	PI	TC	PI	TC	PI
	-15	-16	2.96	1.48	2.89	1.51	2.82	1.54	2.75	1.57	2.68	1.60
	-10	-11	3.52	1.62	3.43	1.65	3.35	1.68	3.27	1.72	3.18	1.75
	-5	-7	3.96	1.70	3.87	1.74	3.77	1.77	3.68	1.81	3.58	1.84
	0	-2	4.58	1.82	4.47	1.85	4.36	1.89	4.25	1.93	4.14	1.97
	5	3	5.21	1.94	5.08	1.98	4.96	2.02	4.83	2.06	4.71	2.10
	7	6	5.57	1.88	5.43	1.92	5.30	1.96	5.17	2.00	5.04	2.04
	10	8	5.76	1.88	5.63	1.92	5.49	1.96	5.35	2.00	5.22	2.04
15	10	5.58	1.64	5.45	1.67	5.32	1.71	5.18	1.74	5.05	1.77	

■ MODEL : AS *A12LC

AFR	10.6
-----	------

		Indoor temperature										
		°CDB	16		18		20		22		24	
Outdoor temperature	°CDB	°CWB	TC	PI	TC	PI	TC	PI	TC	PI	TC	PI
	-15	-16	3.75	1.73	3.66	1.77	3.57	1.81	3.48	1.84	3.39	1.88
	-10	-11	4.45	1.90	4.34	1.94	4.24	1.98	4.13	2.02	4.02	2.06
	-5	-7	5.01	1.99	4.89	2.04	4.77	2.08	4.65	2.12	4.53	2.16
	0	-2	5.79	2.13	5.65	2.17	5.51	2.22	5.37	2.26	5.23	2.31
	5	3	6.58	2.27	6.42	2.32	6.27	2.37	6.11	2.42	5.95	2.46
	7	6	7.04	2.21	6.87	2.25	6.70	2.30	6.53	2.35	6.37	2.39
	10	8	7.29	2.21	7.11	2.26	6.94	2.30	6.77	2.35	6.59	2.39
15	10	7.06	1.92	6.89	1.96	6.72	2.00	6.55	2.04	6.38	2.08	

AFR : Air Flow Rate (m³/min)
 TC : Total Capacity (kW)
 PI : Power Input (kW)

■ MODEL : AS*A14LC

AFR	11.7
-----	------

		Indoor temperature										
		°CDB	16		18		20		22		24	
Outdoor temperature	°CDB	°CWB	TC	PI	TC	PI	TC	PI	TC	PI	TC	PI
	-15	-16	4.70	1.87	4.58	1.91	4.47	1.95	4.36	1.99	4.25	2.03
	-10	-11	5.58	2.05	5.44	2.09	5.31	2.13	5.18	2.17	5.04	2.22
	-5	-7	6.28	2.15	6.13	2.20	5.98	2.24	5.83	2.29	5.68	2.33
	0	-2	7.25	2.30	7.08	2.34	6.91	2.39	6.74	2.44	6.56	2.49
	5	3	8.25	2.45	8.05	2.50	7.86	2.56	7.66	2.61	7.46	2.66
	7	6	8.82	2.38	8.61	2.43	8.40	2.48	8.19	2.53	7.98	2.58
	10	8	9.14	2.38	8.92	2.43	8.70	2.48	8.48	2.53	8.27	2.58
15	10	8.85	2.07	8.64	2.11	8.42	2.16	8.21	2.20	8.00	2.24	

■ MODEL : AS*A18LC

AFR	11.7
-----	------

		Indoor temperature										
		°CDB	16		18		20		22		24	
Outdoor temperature	°CDB	°CWB	TC	PI	TC	PI	TC	PI	TC	PI	TC	PI
	-15	-16	5.09	2.01	4.97	2.05	4.84	2.09	4.72	2.13	4.60	2.17
	-10	-11	6.04	2.19	5.90	2.24	5.75	2.29	5.61	2.33	5.46	2.38
	-5	-7	6.80	2.31	6.64	2.35	6.48	2.40	6.32	2.45	6.15	2.50
	0	-2	7.86	2.46	7.67	2.51	7.48	2.57	7.30	2.62	7.11	2.67
	5	3	8.94	2.63	8.72	2.69	8.51	2.74	8.30	2.80	8.09	2.85
	7	6	9.56	2.55	9.33	2.61	9.10	2.66	8.87	2.71	8.65	2.77
	10	8	9.90	2.56	9.66	2.61	9.43	2.66	9.19	2.72	8.96	2.77
15	10	9.58	2.22	9.35	2.27	9.13	2.31	8.90	2.36	8.67	2.41	

AFR : Air Flow Rate (m³/min)
 TC : Total Capacity (kW)
 PI : Power Input (kW)

7. FAN PERFORMANCE

7-1. AIR VELOCITY DISTRIBUTION

■ MODEL : AS*A07LC, AS*A09LC

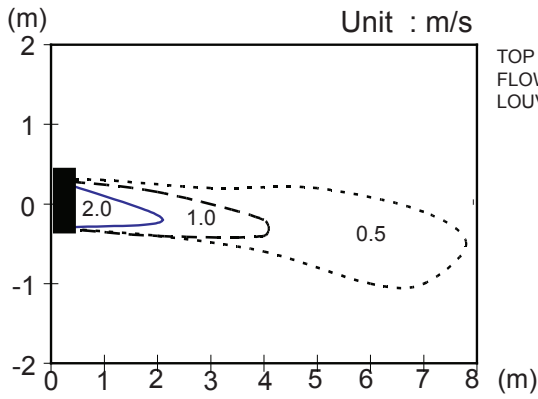

Note :
Fan speed : High
Operation mode :FAN
Voltage : 230V

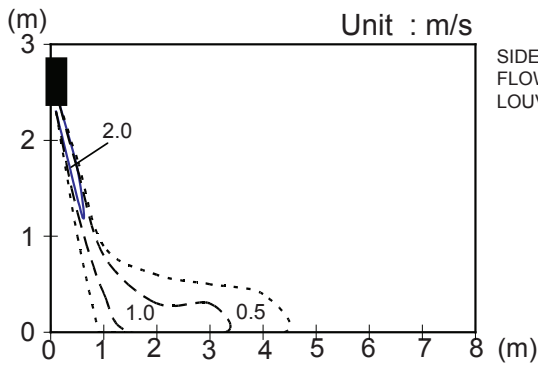
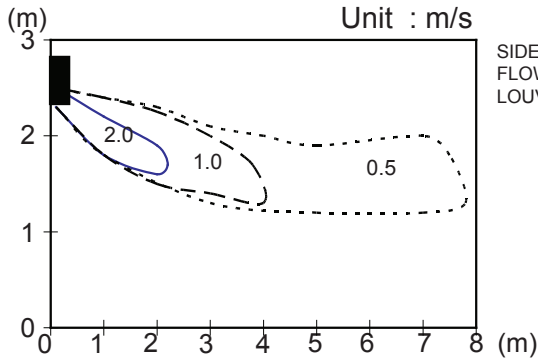
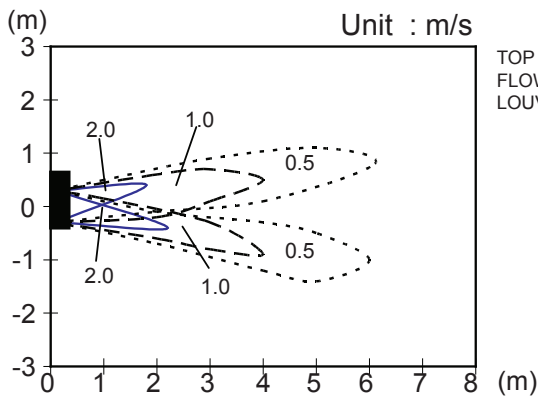

■ MODEL : AS*A12LC

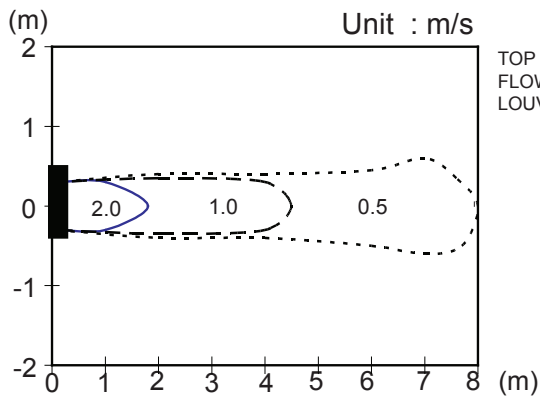

Note :
Fan speed : High
Operation mode :FAN
Voltage : 230V

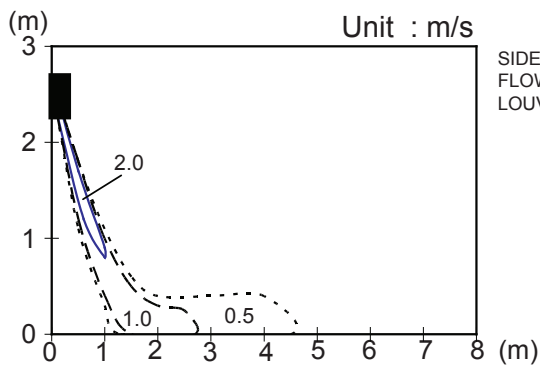
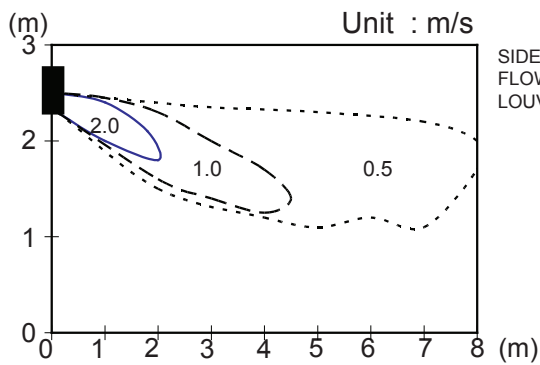
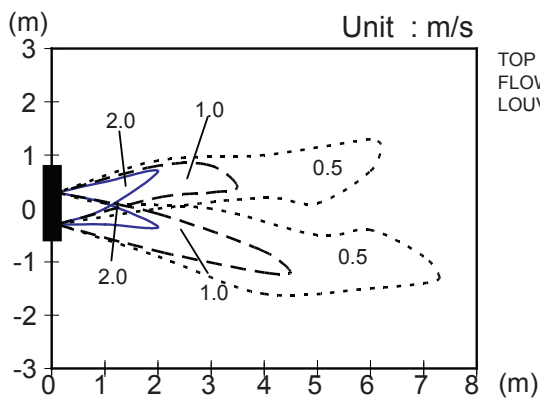

■ MODEL : AS*A14LC, AS*A18LC

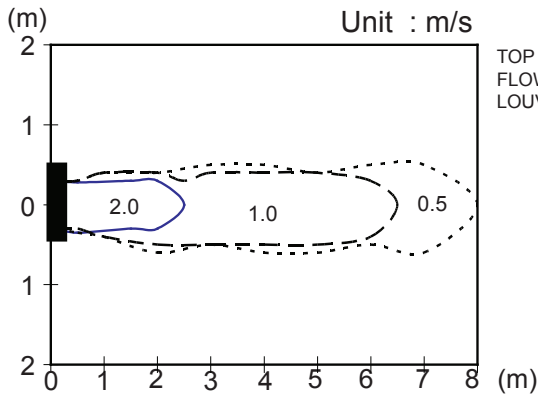

Note :
Fan speed : High
Operation mode :FAN
Voltage : 230V

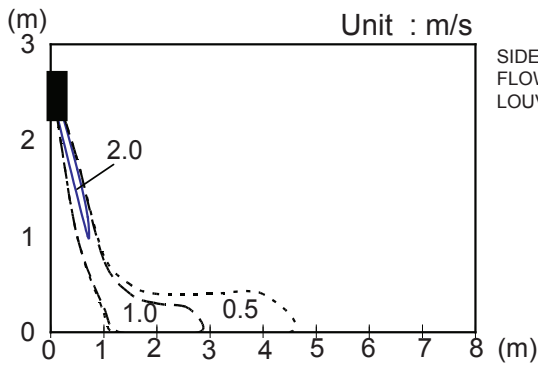
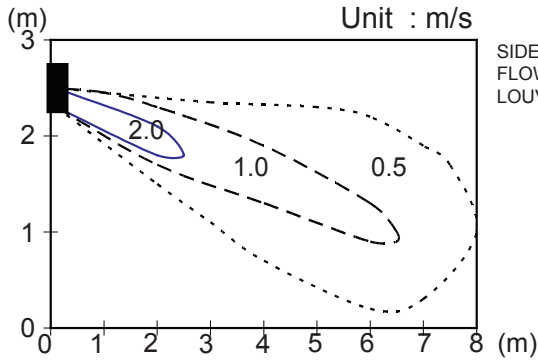
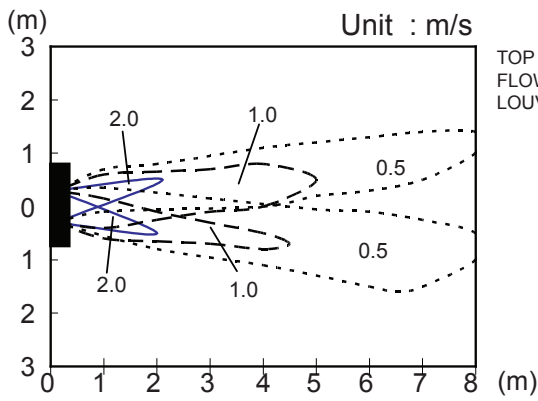

7-2. AIR FLOW

■ MODEL : AS*A07LC

● COOLING

Fan speed	Number of rotations (r.p.m)	Airflow	
HIGH	1300	595	m ³ /h
		165	l/s
		350	CFM
MED	1120	500	m ³ /h
		139	l/s
		294	CFM
LOW	950	410	m ³ /h
		114	l/s
		241	CFM
QUIET	700	290	m ³ /h
		81	l/s
		171	CFM

● HEATING

Fan speed	Number of rotations (r.p.m)	Airflow	
HIGH	1390	645	m ³ /h
		179	l/s
		380	CFM
MED	1200	540	m ³ /h
		150	l/s
		318	CFM
LOW	1000	435	m ³ /h
		121	l/s
		256	CFM
QUIET	760	320	m ³ /h
		89	l/s
		188	CFM

■ MODEL : AS*A09LC

● COOLING

Fan speed	Number of rotations (r.p.m)	Airflow	
HIGH	1300	595	m ³ /h
		165	l/s
		350	CFM
MED	1120	500	m ³ /h
		139	l/s
		294	CFM
LOW	950	410	m ³ /h
		114	l/s
		241	CFM
QUIET	700	290	m ³ /h
		81	l/s
		171	CFM

● HEATING

Fan speed	Number of rotations (r.p.m)	Airflow	
HIGH	1390	645	m ³ /h
		179	l/s
		380	CFM
MED	1200	540	m ³ /h
		150	l/s
		318	CFM
LOW	1000	435	m ³ /h
		121	l/s
		256	CFM
QUIET	760	320	m ³ /h
		89	l/s
		188	CFM

■ MODEL : AS*A12LC

● COOLING

Fan speed	Number of rotations (r.p.m)	Airflow	
HIGH	1370	635	m ³ /h
		176	l/s
		374	CFM
MED	1150	515	m ³ /h
		143	l/s
		303	CFM
LOW	950	410	m ³ /h
		114	l/s
		241	CFM
QUIET	700	290	m ³ /h
		81	l/s
		171	CFM

● HEATING

Fan speed	Number of rotations (r.p.m)	Airflow	
HIGH	1440	670	m ³ /h
		186	l/s
		394	CFM
MED	1200	540	m ³ /h
		150	l/s
		318	CFM
LOW	1000	435	m ³ /h
		121	l/s
		256	CFM
QUIET	760	320	m ³ /h
		89	l/s
		188	CFM

■ MODEL : AS*A14LC

● COOLING

Fan speed	Number of rotations (r.p.m)	Air flow	
HIGH	1480	700	m ³ /h
		194	l/s
		412	CFM
MED	1260	580	m ³ /h
		161	l/s
		341	CFM
LOW	1040	460	m ³ /h
		128	l/s
		271	CFM
QUIET	850	370	m ³ /h
		103	l/s
		218	CFM

● HEATING

Fan speed	Number of rotations (r.p.m)	Air flow	
HIGH	1480	700	m ³ /h
		194	l/s
		412	CFM
MED	1300	600	m ³ /h
		167	l/s
		353	CFM
LOW	1110	500	m ³ /h
		139	l/s
		294	CFM
QUIET	950	420	m ³ /h
		117	l/s
		247	CFM

■ **MODEL : AS*A18LC**● **COOLING**

Fan speed	Number of rotations (r.p.m)	Air flow	
HIGH	1480	700	m ³ /h
		194	l/s
		412	CFM
MED	1260	580	m ³ /h
		161	l/s
		341	CFM
LOW	1040	460	m ³ /h
		128	l/s
		271	CFM
QUIET	850	370	m ³ /h
		103	l/s
		218	CFM

● **HEATING**

Fan speed	Number of rotations (r.p.m)	Air flow	
HIGH	1480	700	m ³ /h
		194	l/s
		412	CFM
MED	1300	600	m ³ /h
		167	l/s
		353	CFM
LOW	1110	500	m ³ /h
		139	l/s
		294	CFM
QUIET	950	420	m ³ /h
		117	l/s
		247	CFM

8. OPERATION NOISE

8-1. NOISE LEVEL CURVE

MODEL : AS*A07LC

● COOLING

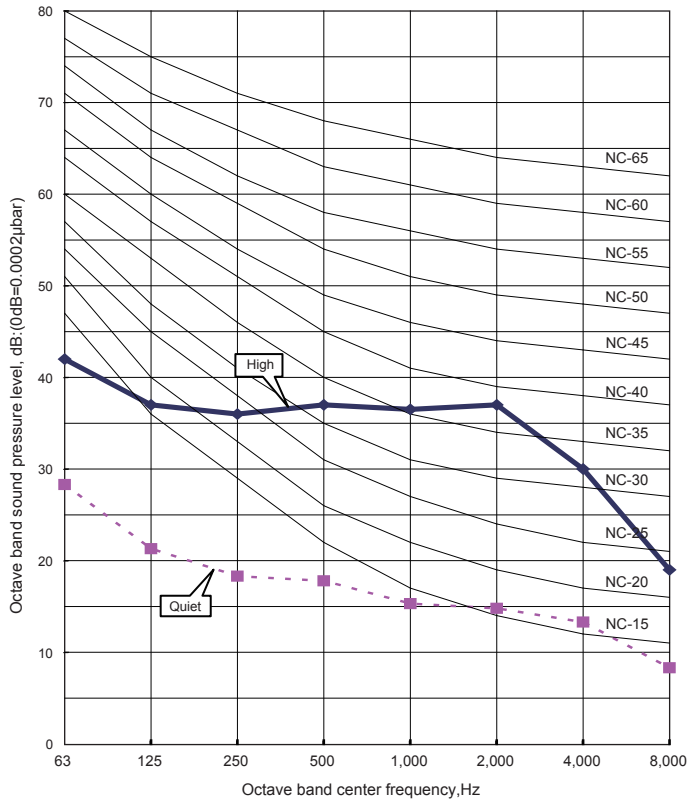

● HEATING

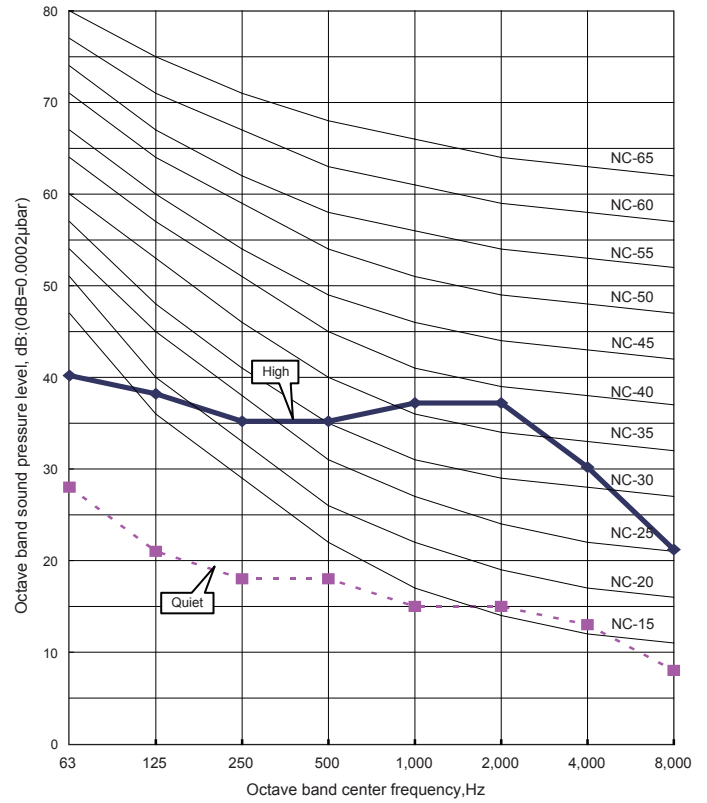

MODEL : AS*A09LC

● COOLING

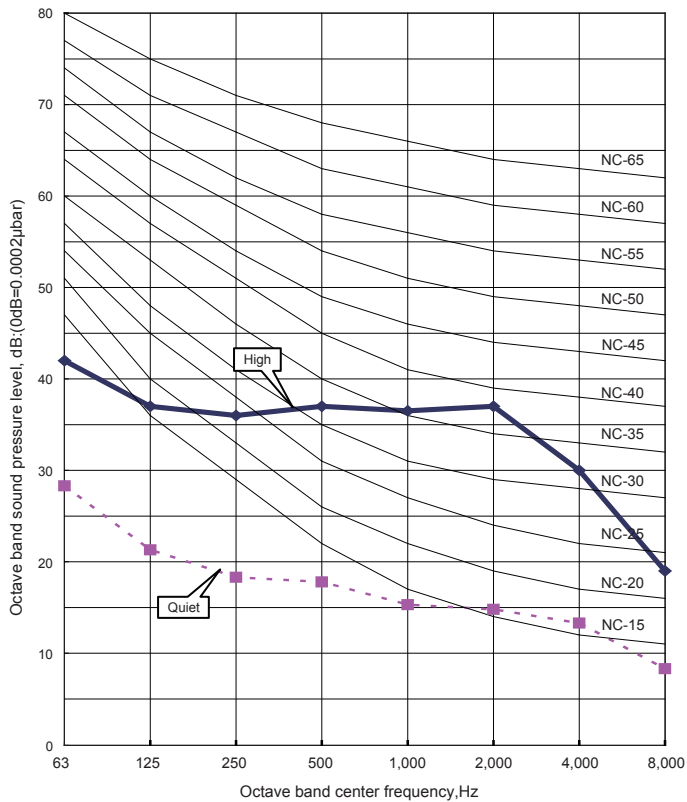

● HEATING

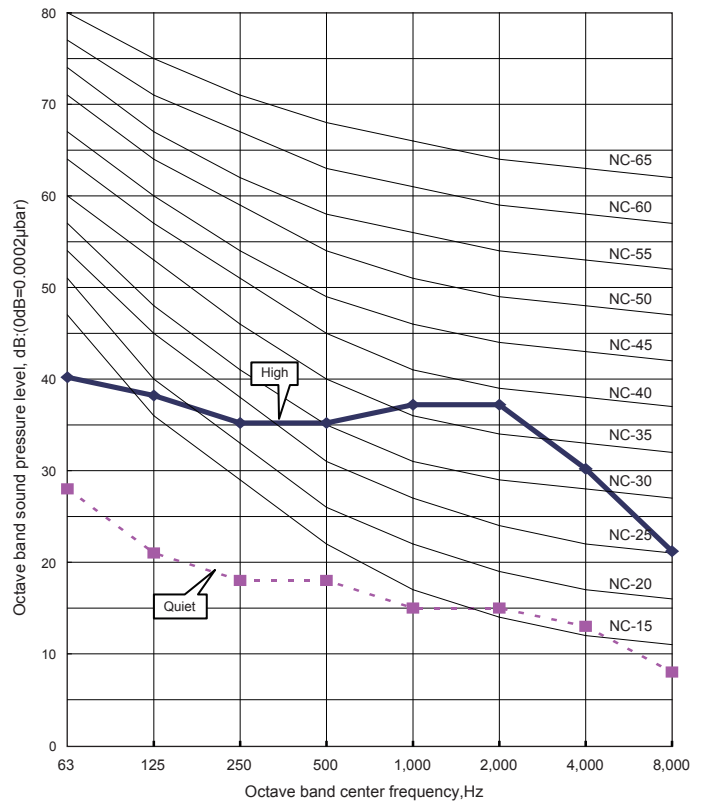

MODEL : AS*A12LC

● COOLING

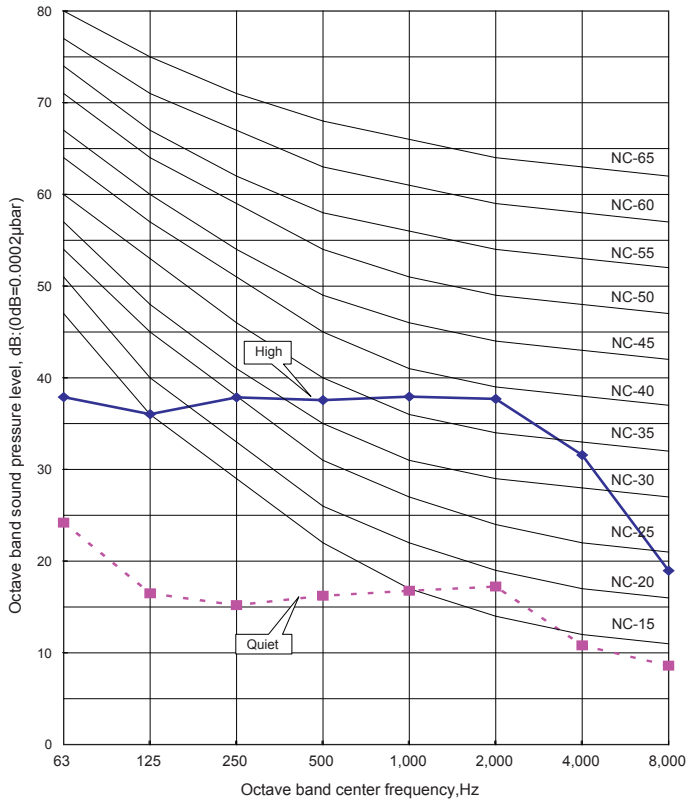

● HEATING

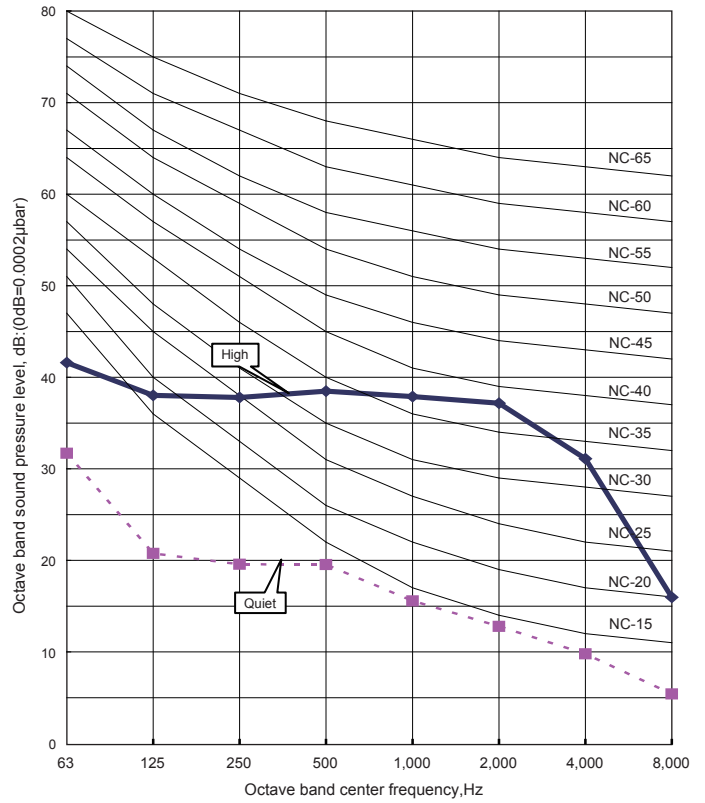

MODEL : AS*A14LC

● COOLING

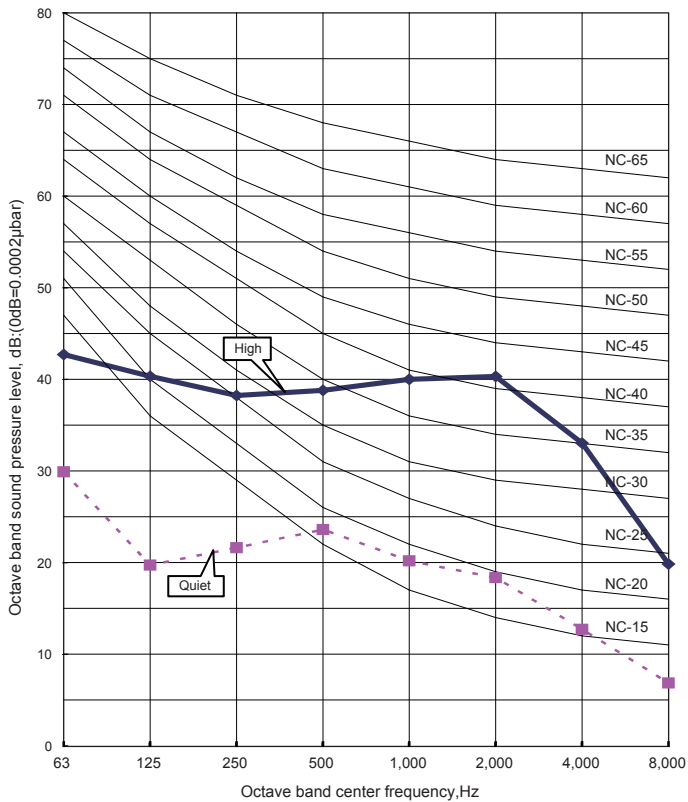

● HEATING

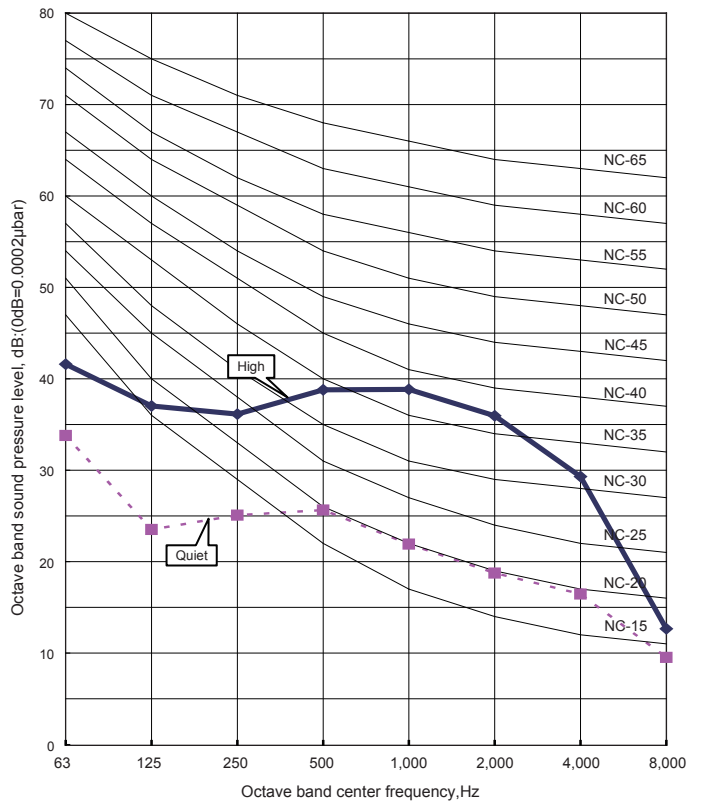

MODEL : AS*A18LC

● COOLING

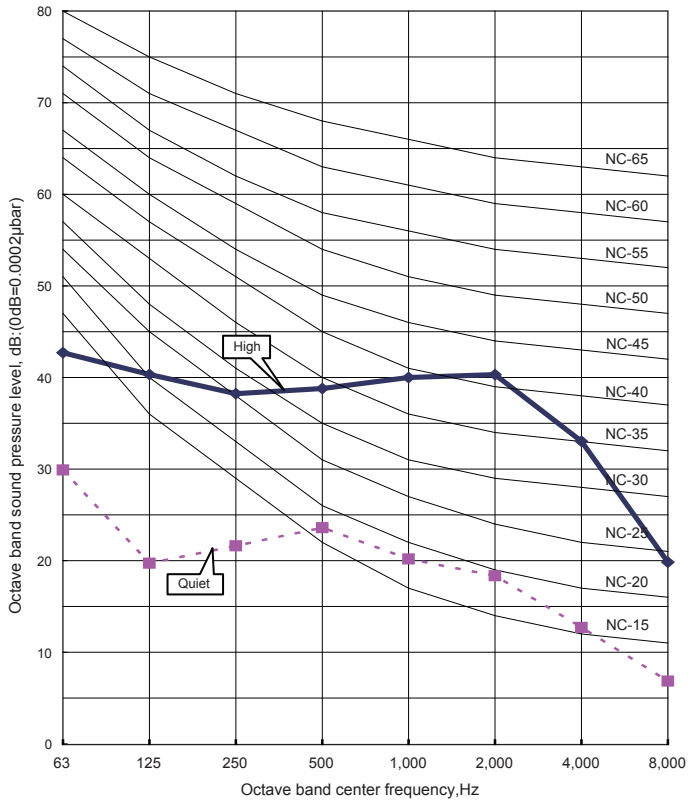

● HEATING

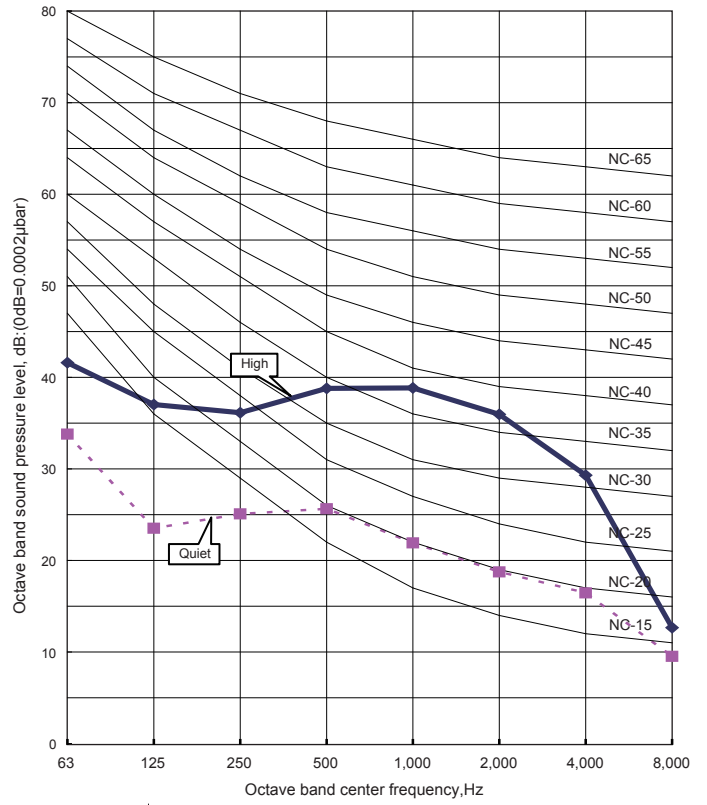

8-2. SOUND LEVEL CHECK POINT

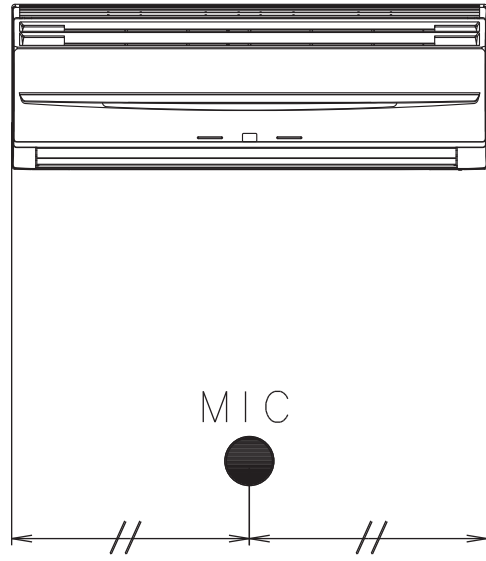
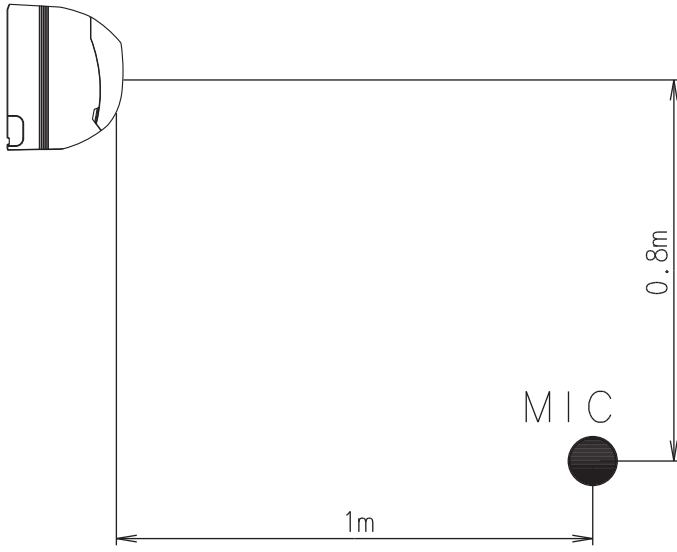

9. ELECTRIC CHARACTERISTICS

Model Name			AS * A07LC	AS * A09LC	AS * A12LC
Power Supply	Voltage	V	230~		
	Frequency	Hz	50		
Max Operating Current		A	8.5	8.5	10.0
*1)Wiring Spec.	Circuit breaker	A	15	15	20
	Connection Cable	mm ²	1.5 - 2.5	1.5 - 2.5	1.5 - 2.5
	Limited wiring length	m	21	21	21

Model Name			AS * A14LC	AS * A18LC
Power Supply	Voltage	V	230~	
	Frequency	Hz	50	
Max Operating Current		A	13.5	13.5
*1)Wiring Spec.	Main Fuse (Circuit breaker) Current	A	20	20
	Connection Cable	mm ²	2 - 3.5	2 - 3.5
	Limited wiring length	m	21	21

*1) Wiring Spec.



Selected Sample

(Selected based on Japan Electrotechnical Standard and Codes Committee E0005)

10. SAFETY DEVICES

	Protection form	Model
		AS * A07LC / AS * A09LC / AS * A12LC / AS * A14LC / AS * A18LC
Circuit protection	Current fuse (PCB)	3.15A 250V
Terminal protection	Current (thermal) fuse	3A 250V 102°C
Fan motor protection	Thermal protection program	100 ⁺¹⁵ ₋₁₀ °C OFF 95 ⁺⁵ ₋₁₀ °C ON

11. OPTIONAL PARTS

Exterior	Parts name	Model No.	Summary
	Apple-catechin filter	UTR-FA03-2	Fine dust, invisible mold spores, and harmful microorganisms are absorbed onto the filter by static electricity , and further growth is inhibited and deactivated by the polyphenol ingredient extracted from apples.
	Ion deodorisation filter	UTR-FA03-3	The filter deodorizes by powerfully decomposing absorbed odors using the oxidizing and reducing effects of ions generated by the ultra fine-particle ceramic.

OUTDOOR UNIT

2. SINGLE TYPE :

AO * R07LCC

AO * R09LCC

AO * R12LCC

AO * R14LCC

AO * R18LCC

1. SPECIFICATIONS

OUTDOOR UNIT
AO*R07-18LC

OUTDOOR UNIT
AO*R07-18LC

Type			INVERTER HEAT PUMP		
Model name			AO * R07LCC	AO * R09LCC	AO * R12LCC
Power source			230V~ 50Hz		
Available voltage range			198 - 264V~ 50Hz		
Starting current		A	3.2	4.0	5.6
Fan	Airflow rate	Cooling	m ³ /h	1,870	1,870
		Heating		1,870	1,870
	Type × Q'ty		Propeller fan × 1		
Motor output		W	26	26	26
Sound pressure level	Cooling		dB(A)	47	47
	Heating			48	48
Heat exchanger type	Dimensions (H × W × D)		mm	508 × 690 × 22	
	Fin pitch			1.3	
	Rows × Stages		1 × 20		
	Pipe type		Copper		
	Fin type		Aluminium		
Compressor	Type × Q'ty		Rotary × 1		
	Motor output		W	750	
Refrigerant	Type		R410A		
	Charge	g	900	1,050	
Refrigerant oil	Type		POE (VG74)		
Enclosure	Material		Steel		
	Colour		Beige		
Dimensions (H × W × D)	Net		mm	540 × 660 × 290	
	Gross			611 × 797 × 401	
Weight	Net		kg (lb.)	32 (70)	
	Gross			35 (77)	
Connection pipe	Size	Liquid	mm	Φ6.35 (Φ 1/4 in.)	
		Gas		Φ9.52 (Φ 3/8 in.)	
	Method		Flare		
	Max. length		m	20 (chargeless : 15)	
	Max. height difference			15	
Operation range	Cooling		°C	10 to 43	
	Heating			-15 to 24	

Note :

Specifications are based on the following conditions.

Cooling : Indoor temperature of 27°CDB/19°CWB. and outdoor temperature of 35°CDB/24°CWB.

Heating : Indoor temperature of 20°CDB/15°CWB. and outdoor temperature of 7°CDB/6°CWB.

Pipe length : 7.5 m, Height difference : 0 m. (Outdoor unit - Indoor unit)

Type			INVERTER HEAT PUMP		
Model name			AO * R14LCC	AO * R18LCC	
Power source			230V~ 50Hz		
Available voltage range			198 - 264V~ 50Hz		
Starting current		A	6.4	7.7	
Fan	Airflow rate	Cooling	m ³ /h	1,910	2,000
		Heating		1,750	1,910
	Type × Q'ty		Propeller fan × 1		
Motor output		W	30	30	
Sound pressure level	Cooling		dB(A)	48	50
	Heating			49	50
Heat exchanger type	Dimensions (H × W × D)		mm	546 × 876 × 36.4	
	Fin pitch			1.3	
	Rows × Stages		2 × 26		
	Pipe type		Copper		
	Fin type		Aluminium		
Compressor	Type × Q'ty		Rotary × 1		
	Motor output		W	1,100	
Refrigerant	Type		R410A		
	Charge		g	1,150	
Refrigerant oil	Type		POE(VG74)		
Enclosure	Material		Steel		
	Colour		Beige		
Dimensions (H × W × D)	Net		mm	578 × 790 × 300	
	Gross			648 × 910 × 380	
Weight	Net		kg(lb.)	40 (88)	
	Gross			44 (97)	
Connection pipe	Size	Liquid	mm	Φ6.35 (Φ 1/4 in.)	
		Gas		Φ12.7 (Φ 1/2 in.)	
	Method		Flare		
	Max. length		m	20 (chargeless : 15)	
	Max. height difference			15	
Operation range	Cooling		°C	-10 to 43	
	Heating			-15 to 24	

Note :

Specifications are based on the following conditions.

Cooling : Indoor temperature of 27°CDB/19°CWB. and outdoor temperature of 35°CDB/24°CWB.

Heating : Indoor temperature of 20°CDB/15°CWB. and outdoor temperature of 7°CDB/6°CWB.

Pipe length : 7.5 m, Height difference : 0 m. (Outdoor unit - Indoor unit)

2. DIMENSIONS

■ MODEL : AO*R07LC, AO*R09LC

(Unit : mm)

OUTDOOR UNIT
AO*R07-18LC

OUTDOOR UNIT
AO*R07-18LC

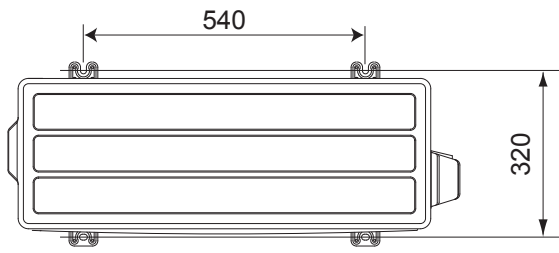

Top view

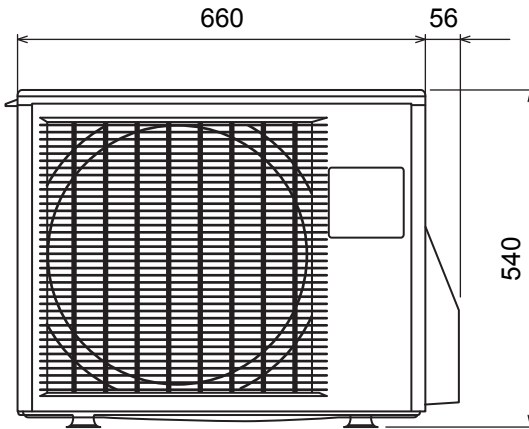

Front view

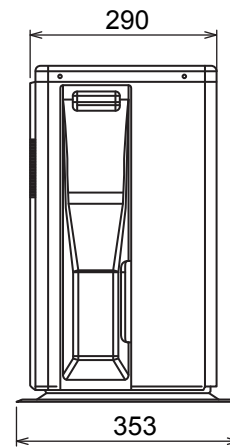

Side view

■ INSTALLATION PLACE

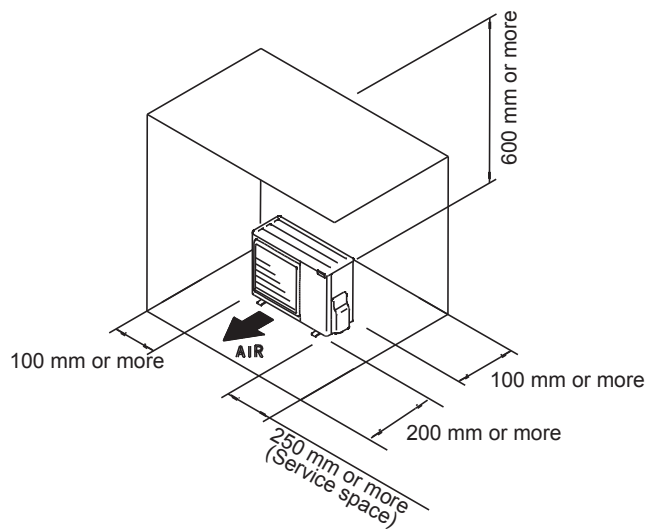

If the space is larger that is stated, the condition will be the same as that are no obstacles.

MODEL : AO*R12LC

(Unit : mm)

OUTDOOR UNIT
AO*R07-18LC

OUTDOOR UNIT
AO*R07-18LC

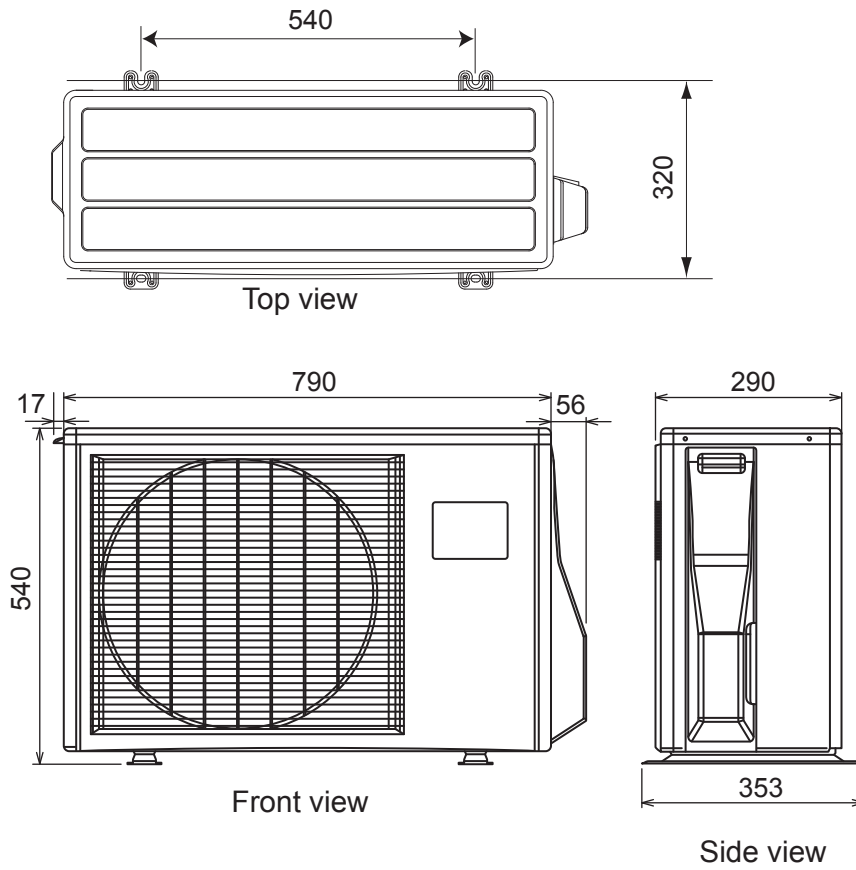

INSTALLATION PLACE

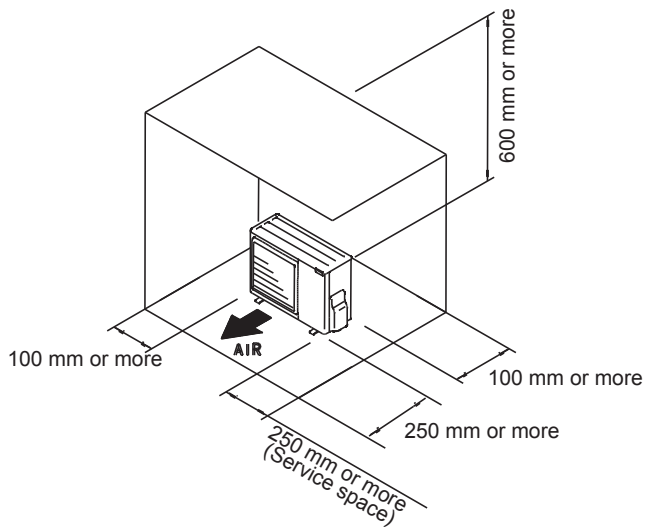

If the space is larger that is stated, the condition will be the same as that are no obstacles.

MODEL : AO*R14LC, AO*R18LC

(Unit : mm)

OUTDOOR UNIT
AO*R07-18LC

OUTDOOR UNIT
AO*R07-18LC

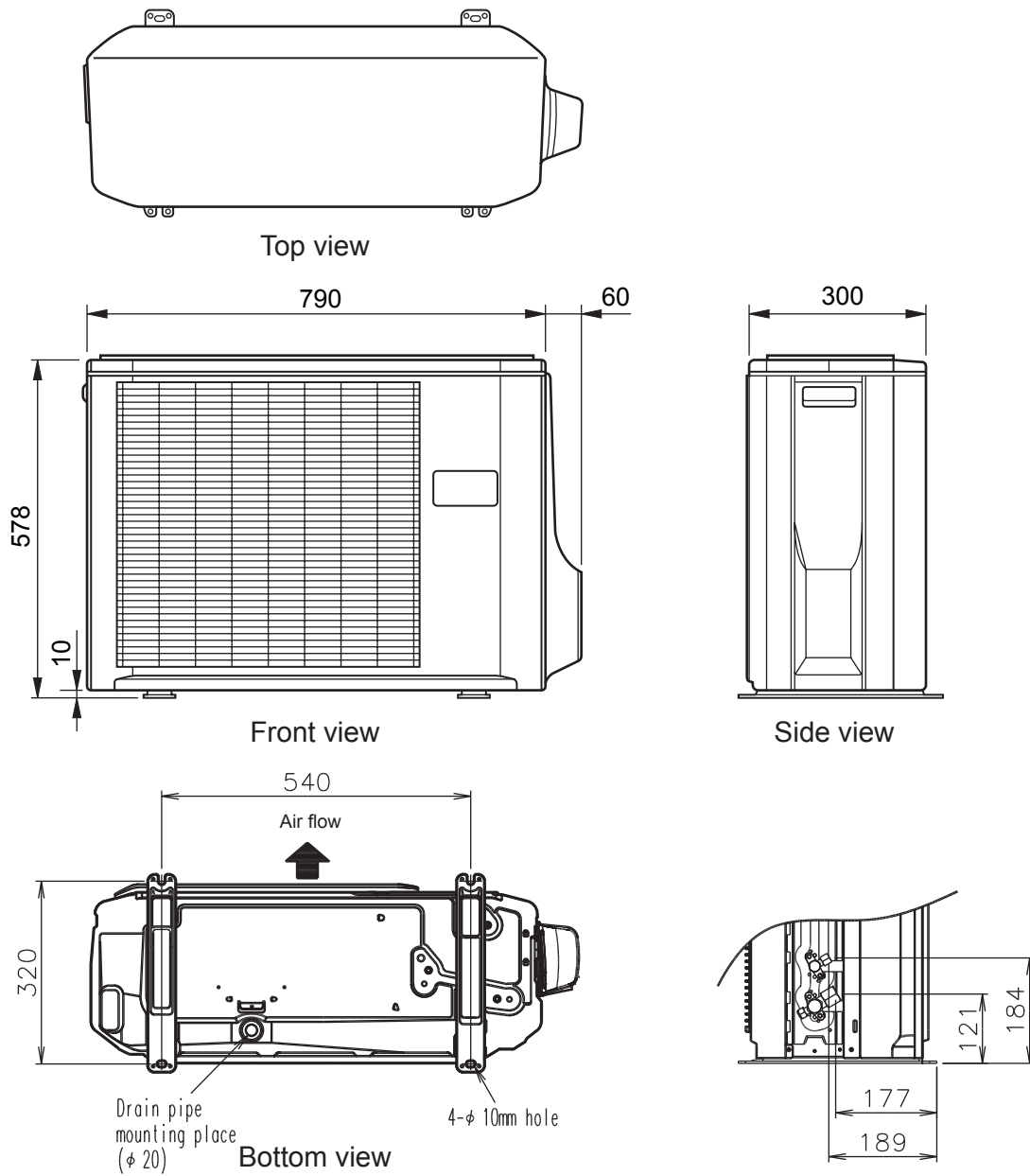

INSTALLATION PLACE

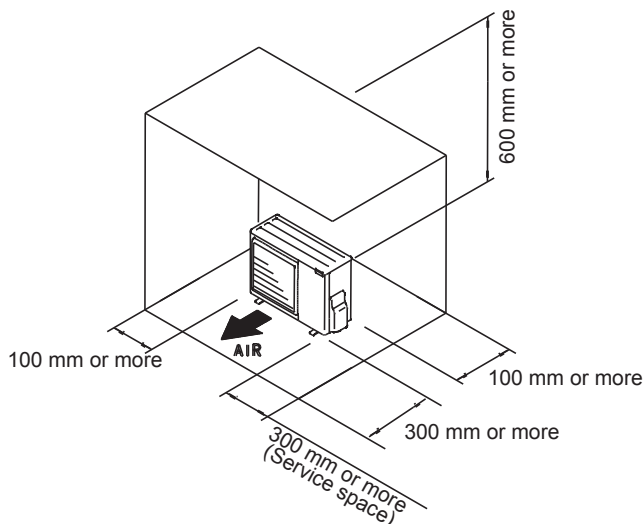

If the space is larger than that is stated, the condition will be the same as that are no obstacles.

3. REFRIGERANT CIRCUIT

■ MODEL : AO*R07LC, AO*R09LC

OUTDOOR UNIT
AO*R07-18LC

OUTDOOR UNIT
AO*R07-18LC

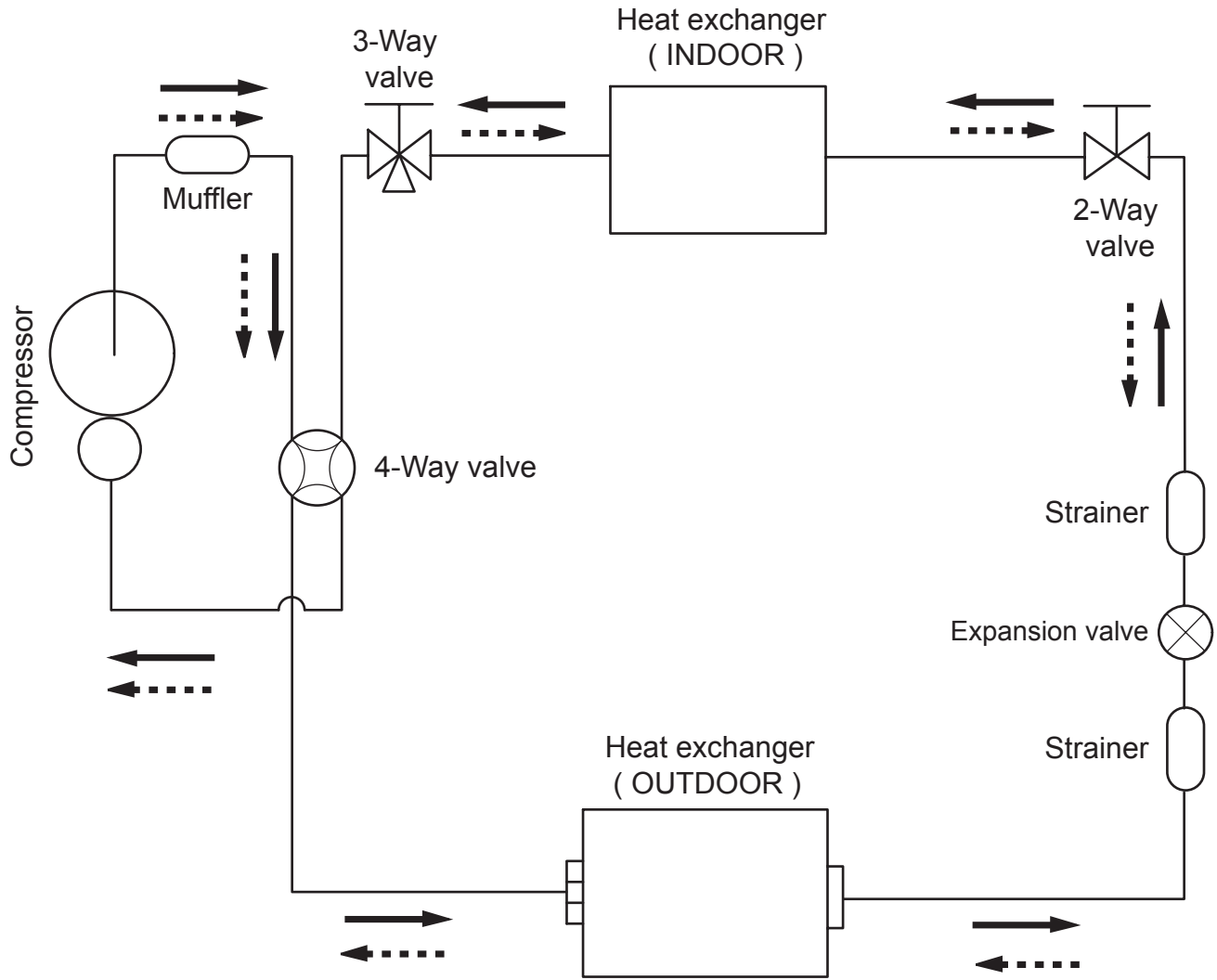

————→ Cooling
·····→ Heating

Refrigerant pipe diameter
Liquid : 1/4" (6.35 mm)
Gas : 3/8" (9.52 mm)

■ MODEL : AO*R12LC

OUTDOOR UNIT
AO*R07-18LC

OUTDOOR UNIT
AO*R07-18LC

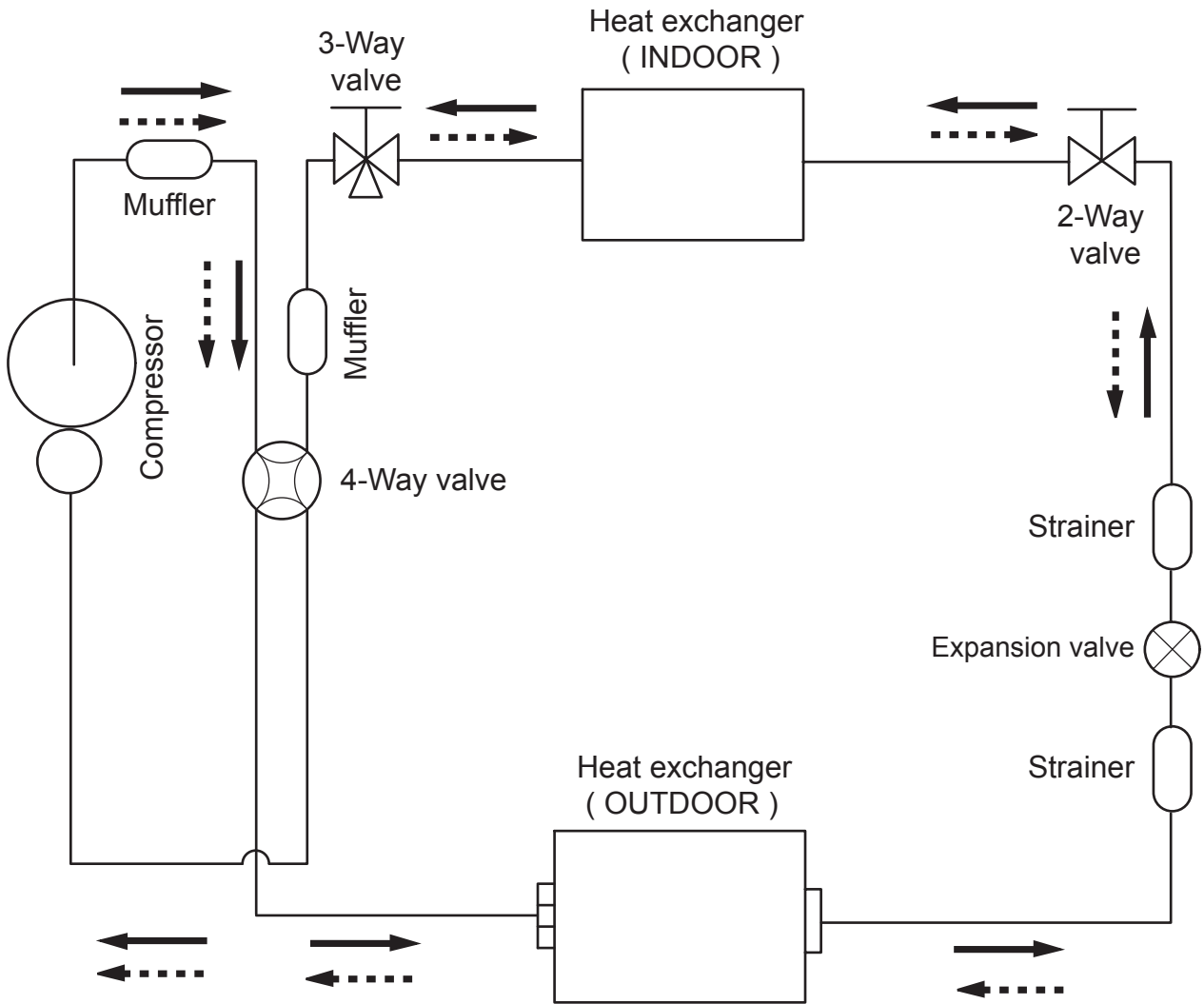

→ Cooling
- - - - - Heating

Refrigerant pipe diameter
Liquid : 1/4" (6.35 mm)
Gas : 3/8" (9.52 mm)

■ MODEL : AO*R14LC, AO*R18LC

OUTDOOR UNIT
AO*R07-18LC

OUTDOOR UNIT
AO*R07-18LC

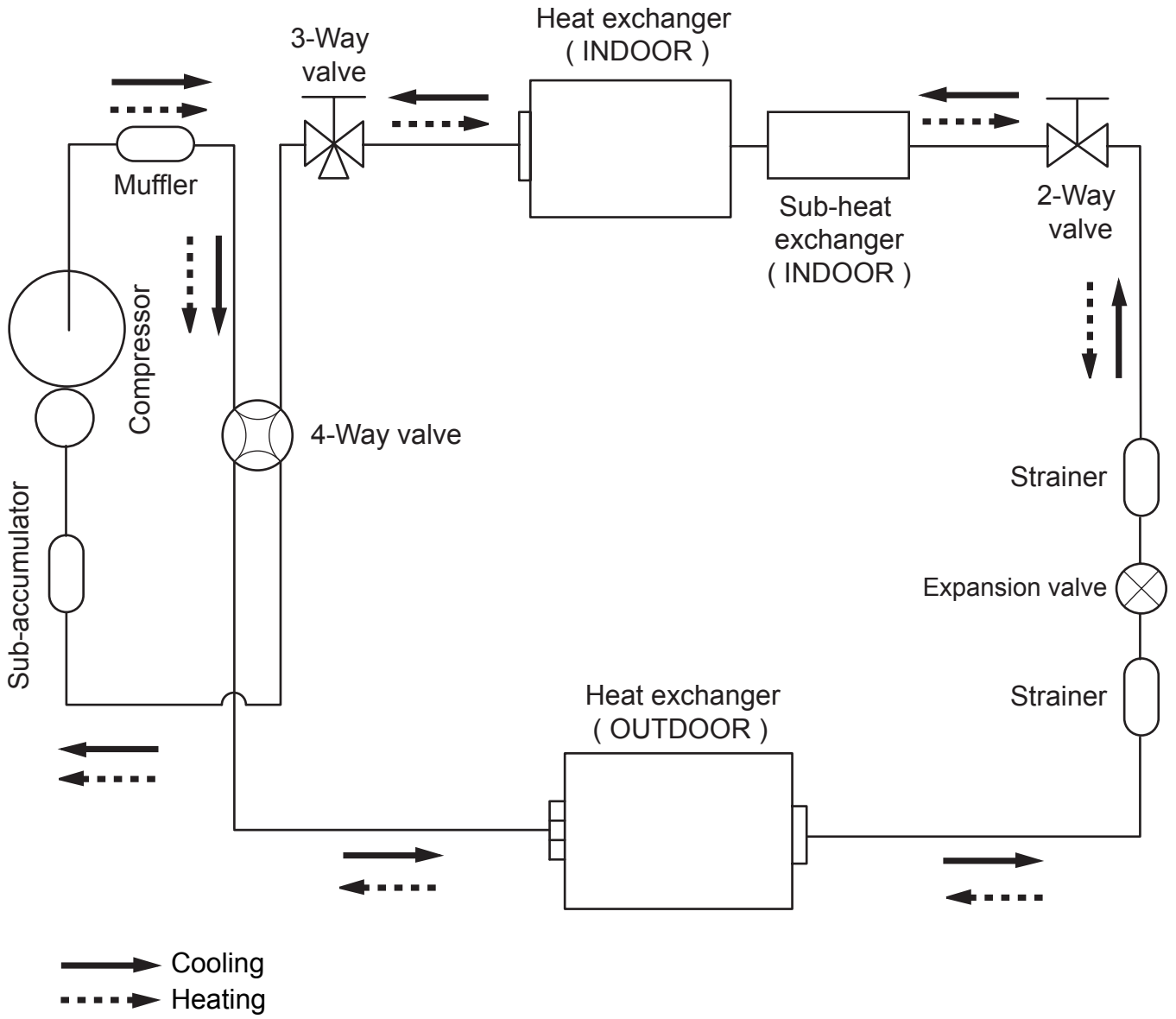

Refrigerant pipe diameter
 Liquid : 1/4" (6.35 mm)
 Gas : 1/2" (12.7 mm)

4. WIRING DIAGRAMS

■ MODEL : AO*R07LC, AO*R09LC

OUTDOOR UNIT
AO*R07-18LC

OUTDOOR UNIT
AO*R07-18LC

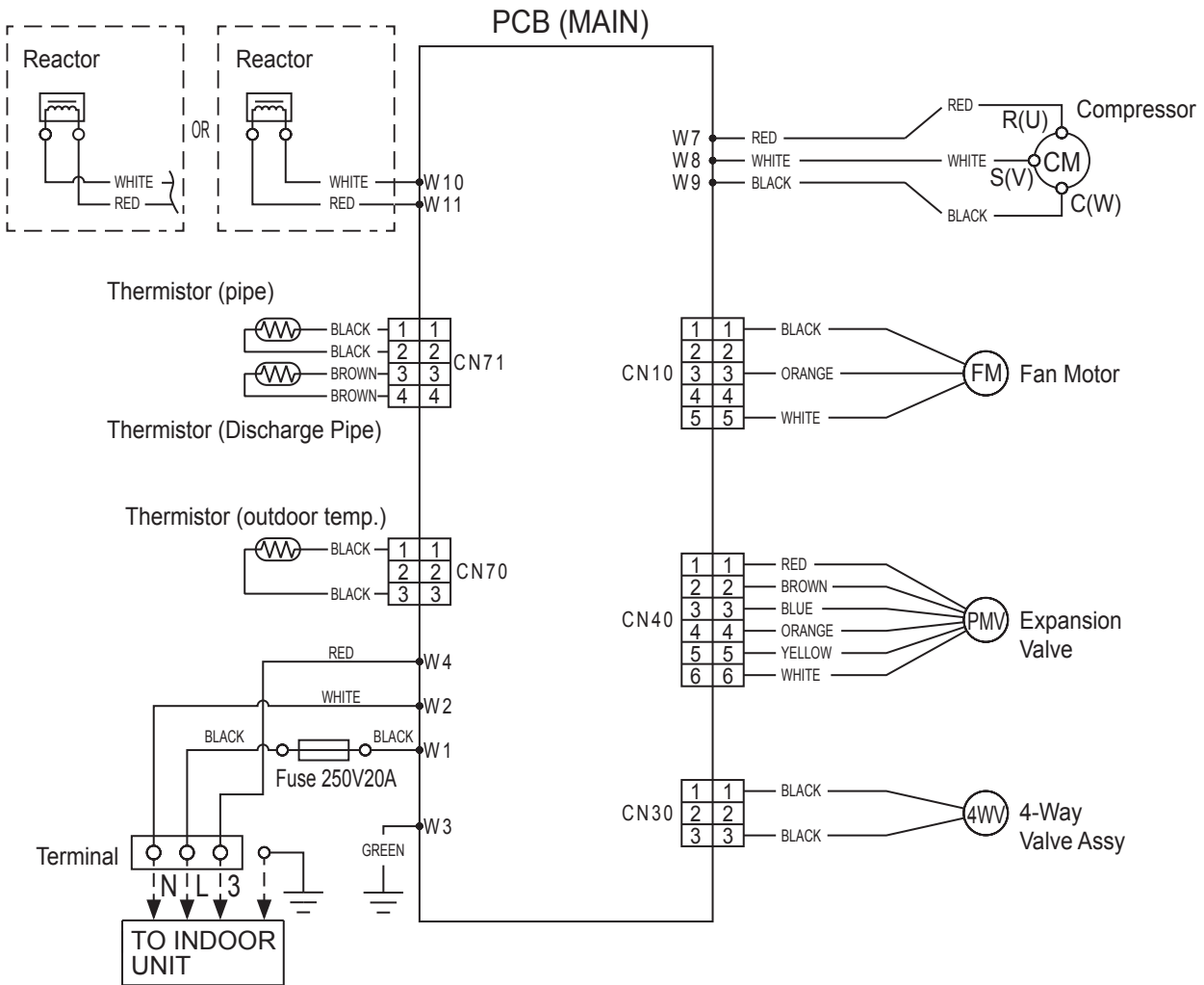

MODEL : AO*R12LC

OUTDOOR UNIT
AO*R07-18LC

OUTDOOR UNIT
AO*R07-18LC

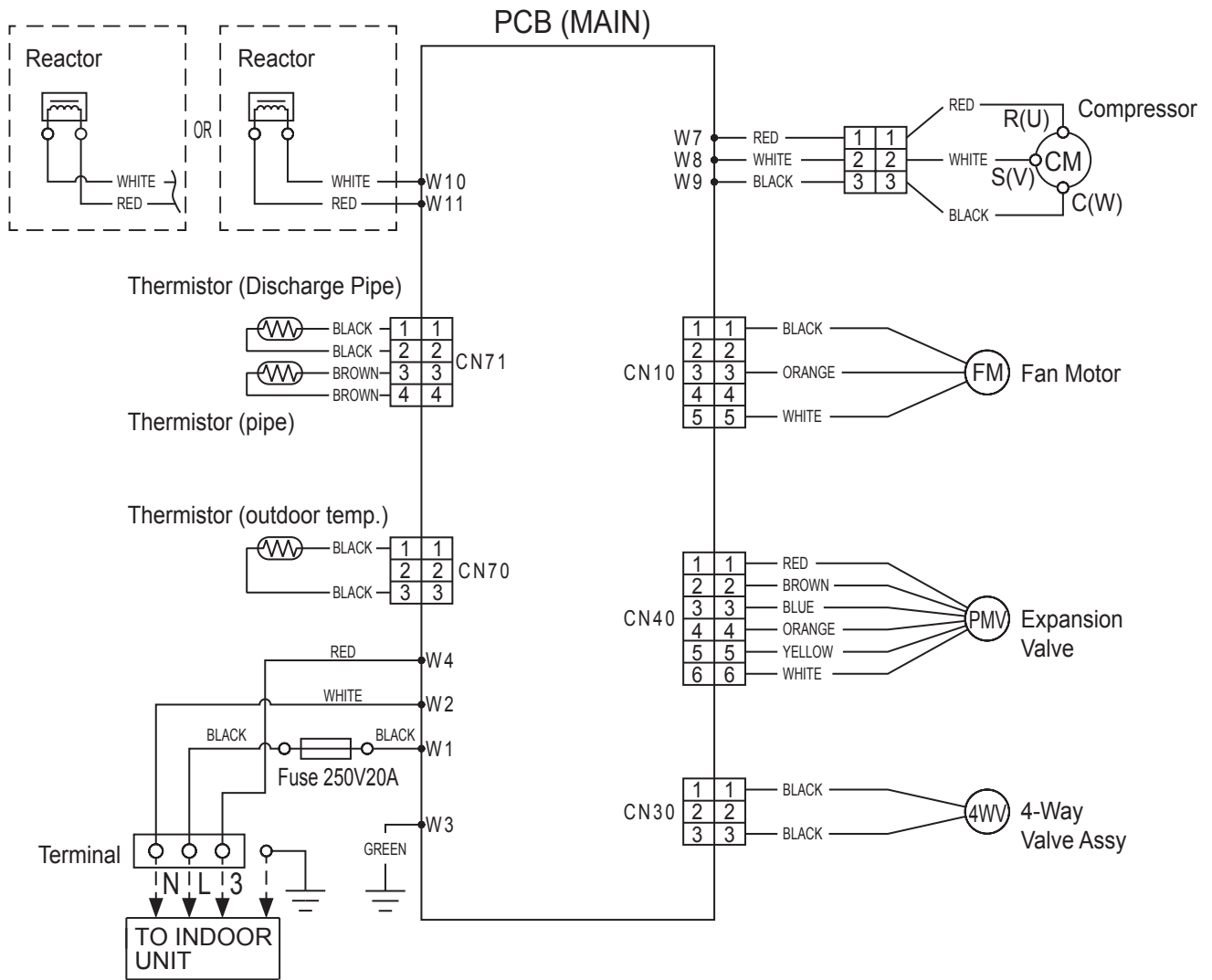

MODEL : AO*R14LC, AO*R18LC

OUTDOOR UNIT
AO*R07-18LC

OUTDOOR UNIT
AO*R07-18LC

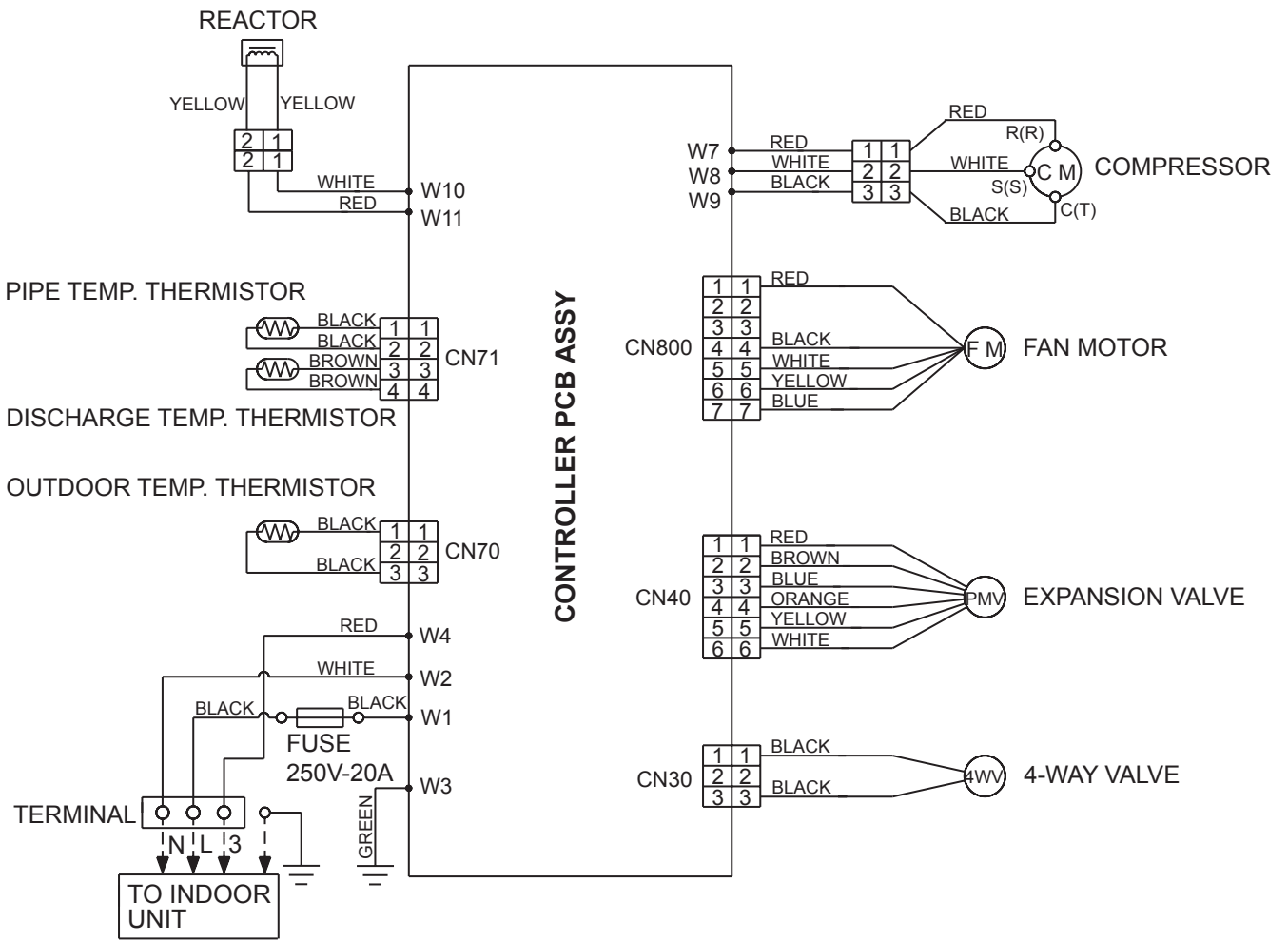

5. COEFFICIENT OF COMPENSATION FOR PIPE LENGTH AND HEIGHT DIFFERENCE

■ MODEL : AO * R07LC, AO * R09LC, AO * R12LC, AO * R14LC, AO * R18LC

OUTDOOR UNIT
AO*R07-18LC

OUTDOOR UNIT
AO*R07-18LC

COOLING			Pipe length (m)				
			5	7.5	10	15	20
Height difference H (m)	* 1 Indoor unit is upper than outdoor unit.	15	-	-	-	0.953	0.950
		10	-	-	0.983	0.968	0.966
		7.5	-	0.988	0.987	0.972	0.970
		5	0.992	0.992	0.991	0.976	0.974
	0	1.000	1.000	0.999	0.984	0.982	
	* 2 Indoor unit is under than outdoor unit	-5	1.000	1.000	0.999	0.984	0.982
		-7.5	-	1.000	0.999	0.984	0.982
		-10	-	-	0.999	0.984	0.982
-15		-	-	-	0.984	0.982	

HEATING			Pipe length (m)				
			5	7.5	10	15	20
Height difference H (m)	* 1 Indoor unit is upper than outdoor unit.	15	-	-	-	0.920	0.894
		10	-	-	0.982	0.920	0.894
		7.5	-	1.000	0.982	0.920	0.894
		5	0.993	1.000	0.982	0.920	0.894
	0	0.993	1.000	0.982	0.920	0.894	
	* 2 Indoor unit is under than outdoor unit	-5	0.988	0.995	0.977	0.916	0.889
		-7.5	-	0.993	0.975	0.913	0.887
		-10	-	-	0.972	0.911	0.885
-15		-	-	-	0.902	0.876	

Height difference H

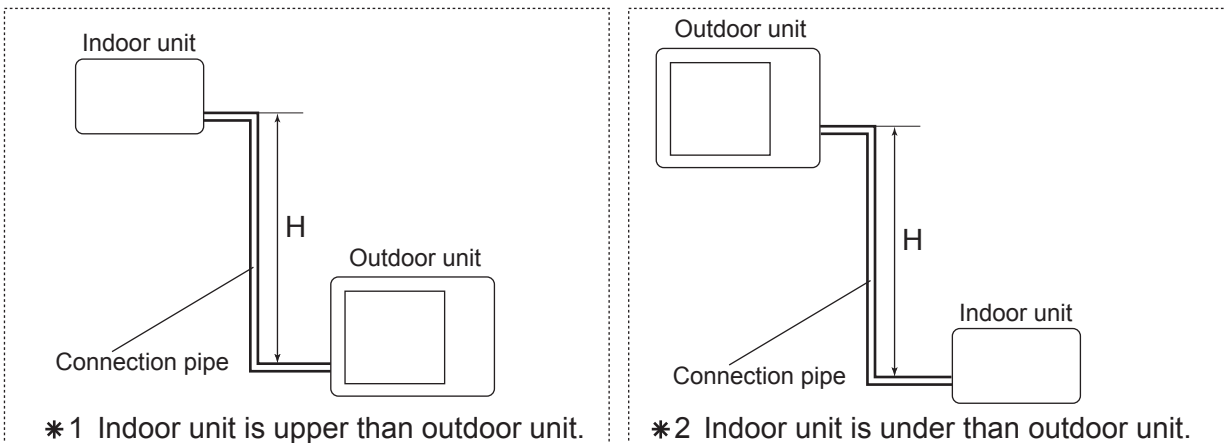

6. ADDITIONAL CHARGE CALCULATION

■ MODEL : AO * R07LC, AO * R09LC

Refrigerant type	R410A	
Refrigerant amount	g	900

● REFRIGERANT CHARGE

Pipe length	m	~15	20	20g/m
Additional charge	g	0 (Chargeless)	+100	

■ MODEL : AO * R12LC

Refrigerant type	R410A	
Refrigerant amount	g	1,050

● REFRIGERANT CHARGE

Pipe length	m	~15	20	20g/m
Additional charge	g	0 (Chargeless)	+100	

■ MODEL : AO * R14LC, AO * R18LC

Refrigerant type	R410A	
Refrigerant amount	g	1150

● REFRIGERANT CHARGE

Pipe length	m	~15	20	20g/m
Additional charge	g	0 (Chargeless)	+100	

7. AIR FLOW

■ MODEL : AO * R07LC, AO * R09LC

● COOLING

Number of rotations (r.p.m)	Airflow	
	800	1870
519		l/s
1101		CFM

● HEATING

Number of rotations (r.p.m)	Airflow	
	800	1870
519		l/s
1101		CFM

■ MODEL : AO * R12LC

● COOLING

Number of rotations (r.p.m)	Airflow	
	830	1850
514		l/s
1089		CFM

● HEATING

Number of rotations (r.p.m)	Airflow	
	830	1850
514		l/s
1089		CFM

■ **MODEL : AO * R14LC**

● **COOLING**

Number of rotations (r.p.m)	Air flow	
820	1910	m ³ /h
	531	l/s
	1124	CFM

● **HEATING**

Number of rotations (r.p.m)	Air flow	
750	1750	m ³ /h
	486	l/s
	1030	CFM

■ **MODEL : AO * R18LC**

● **COOLING**

Number of rotations (r.p.m)	Air flow	
860	2000	m ³ /h
	556	l/s
	1177	CFM

● **HEATING**

Number of rotations (r.p.m)	Air flow	
820	1910	m ³ /h
	531	l/s
	1124	CFM

8. OPERATION NOISE

8-1. NOISE LEVEL CURVE

MODEL : AO * R07LC

COOLING

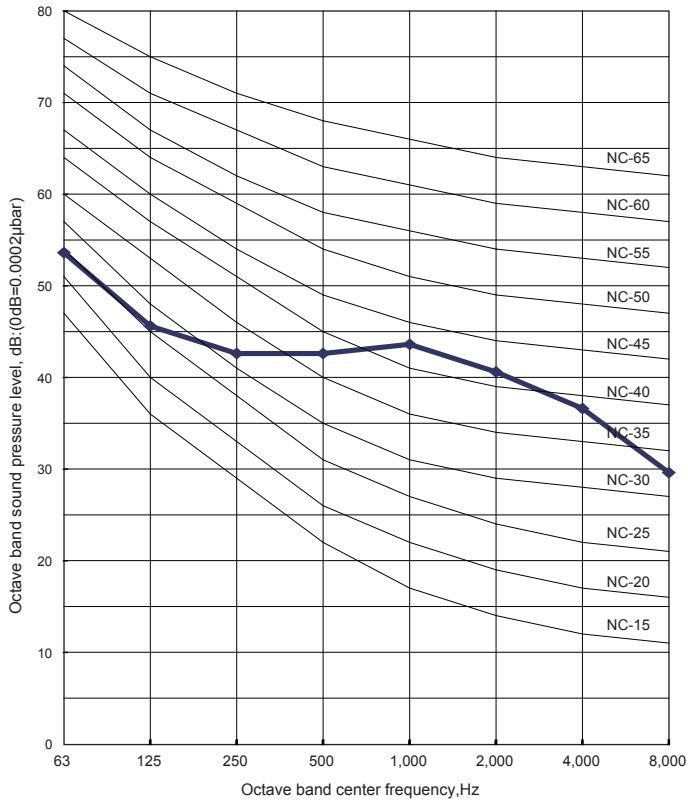

HEATING

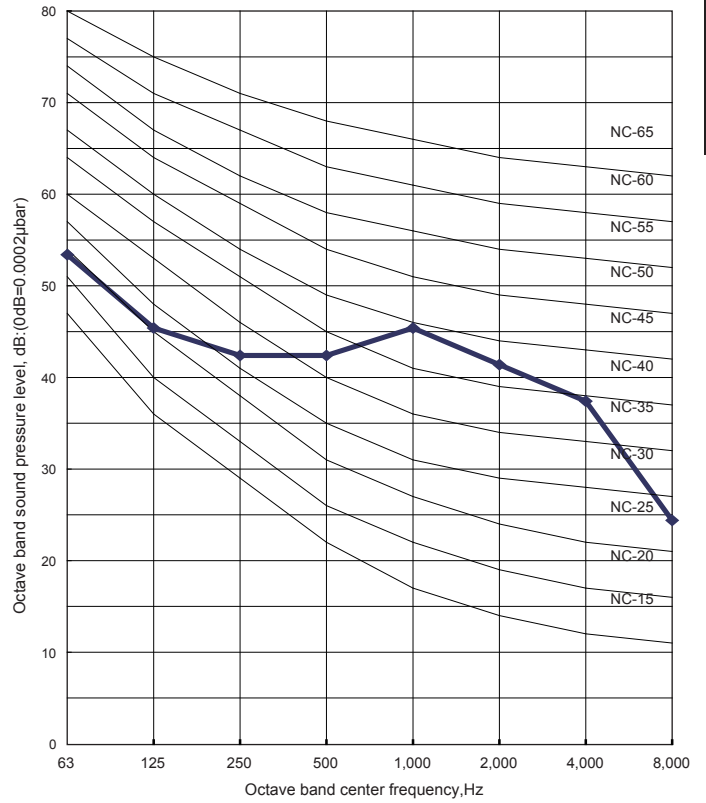

MODEL : AO * R09LC

COOLING

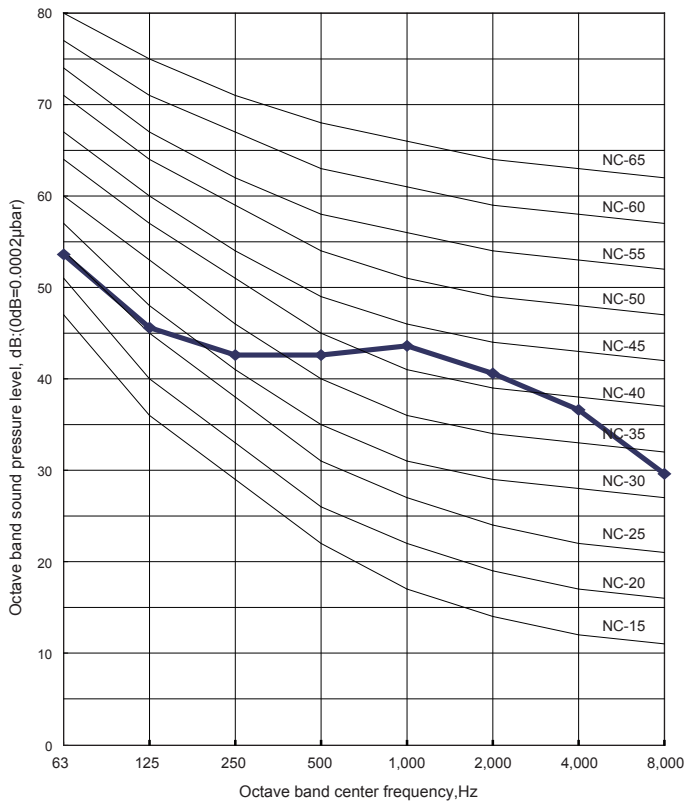

HEATING

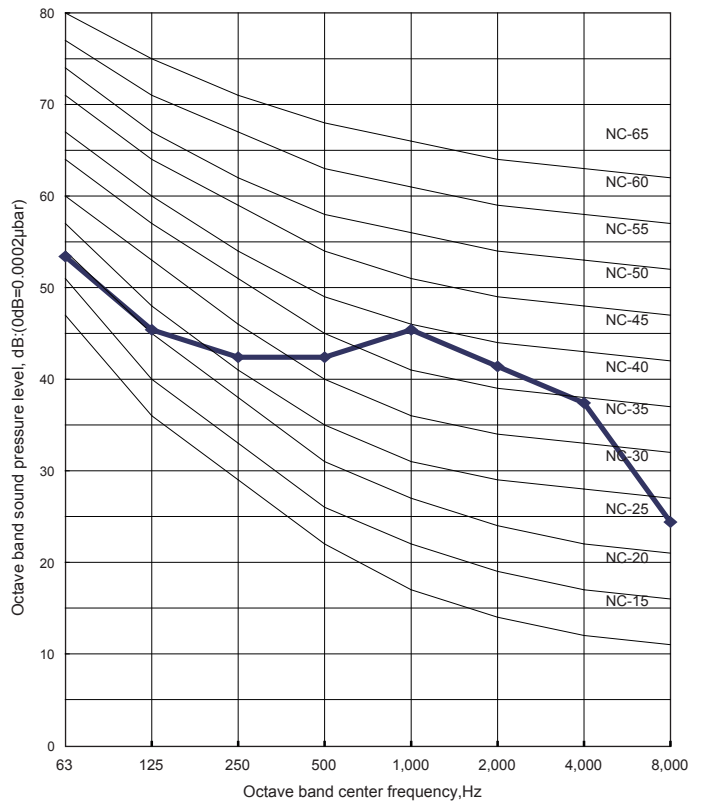

OUTDOOR UNIT
AO*R07-18LC

OUTDOOR UNIT
AO*R07-18LC

MODEL : AO * R12LC

● COOLING

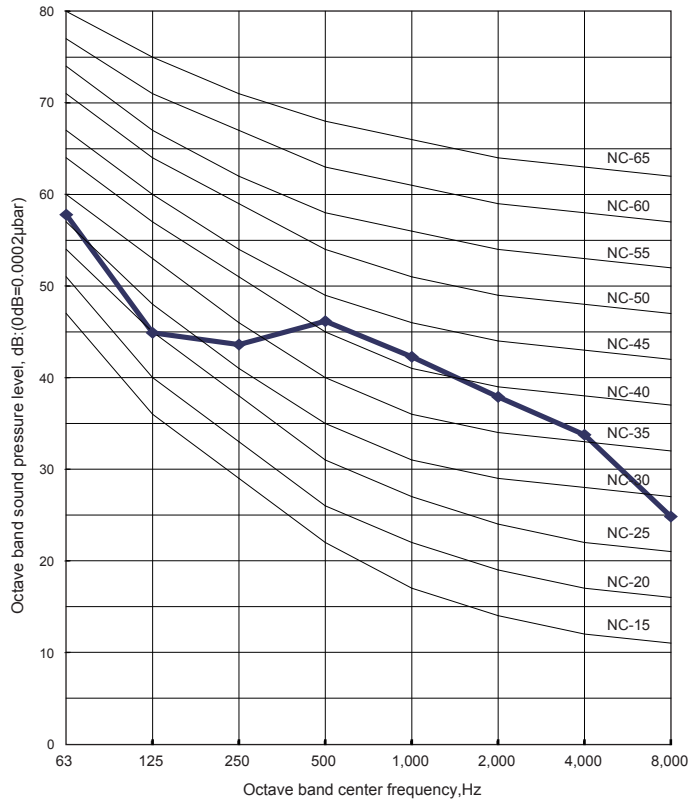

● HEATING

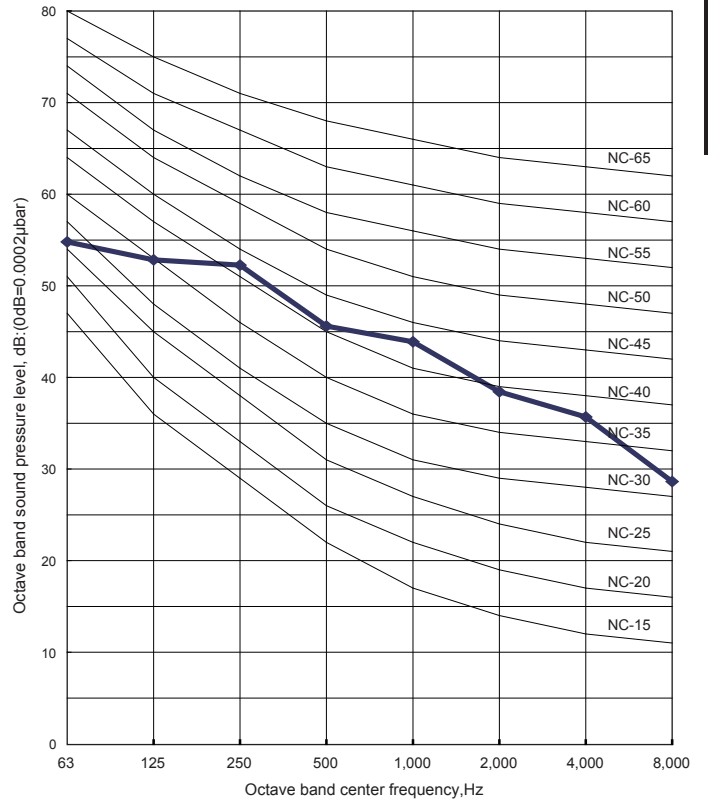

MODEL : AO * R14LC

● COOLING

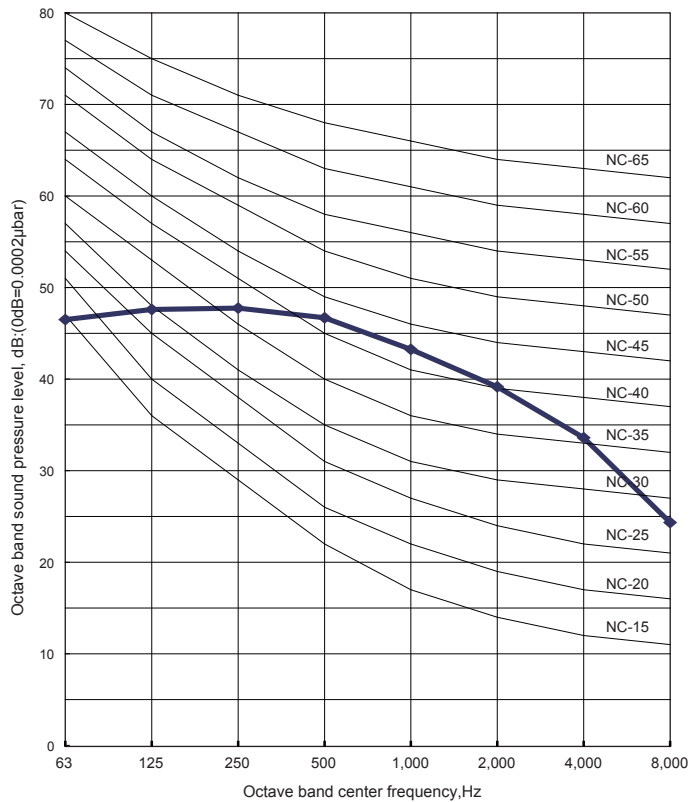

● HEATING

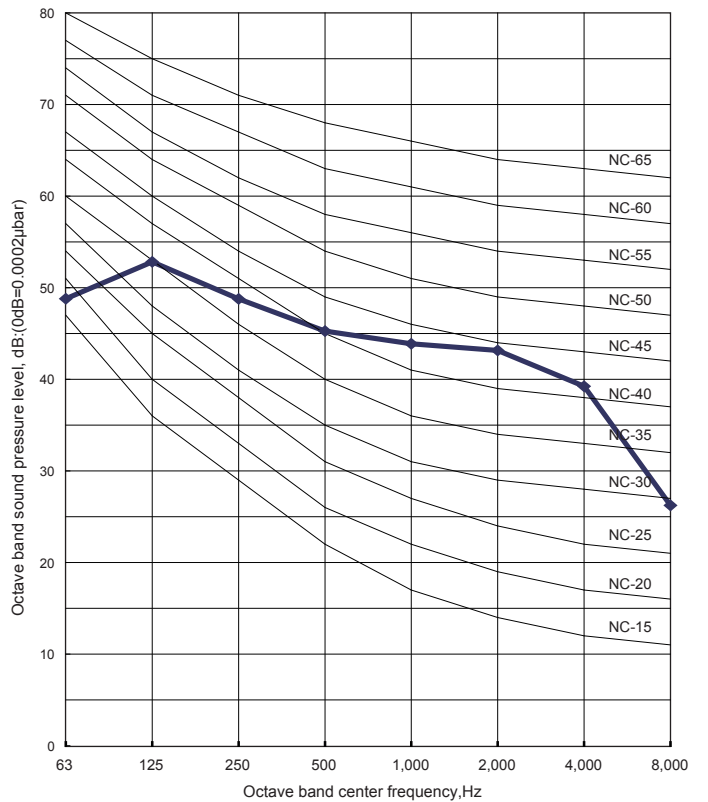

MODEL : AO * R18LC

● COOLING

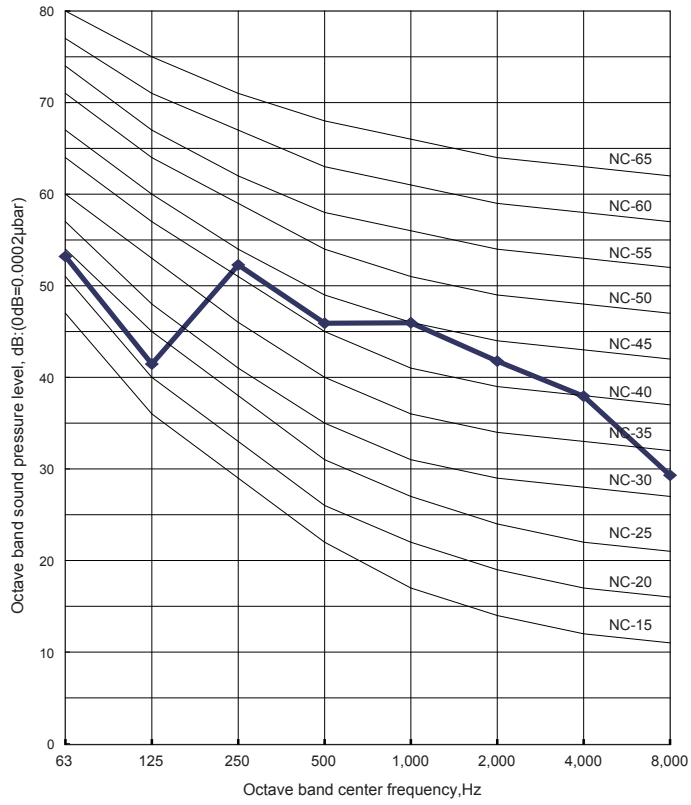

● HEATING

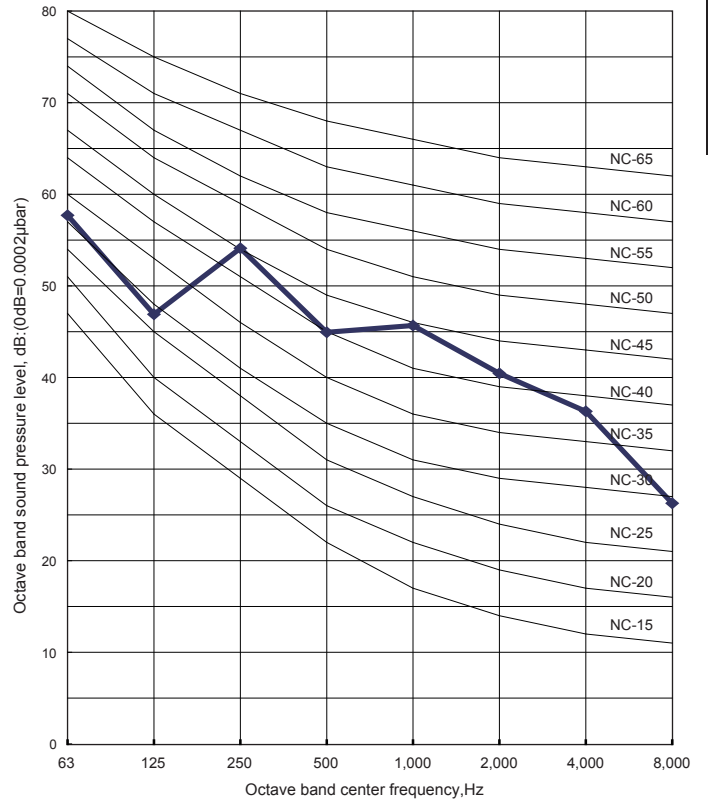

8-2. SOUND LEVEL CHECK POINT

OUTDOOR UNIT
AO*R07-18LC

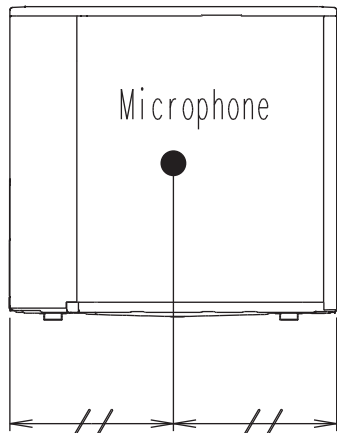
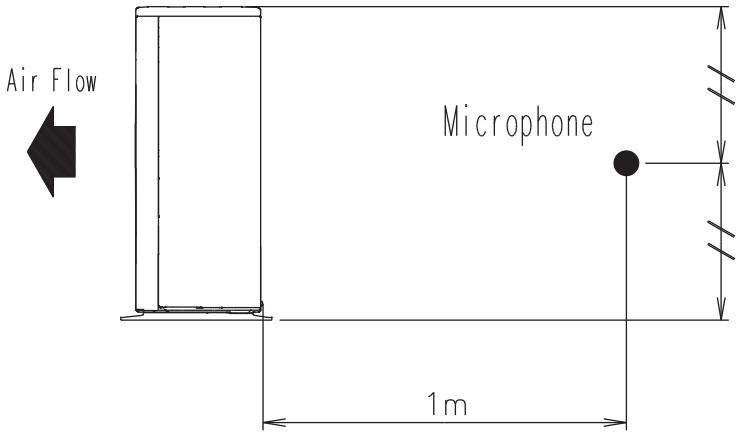

OUTDOOR UNIT
AO*R07-18LC

9. ELECTRIC CHARACTERISTICS

Model Name			AO * R07LC	AO * R09LC	AO * R12LC
Power Supply	Voltage	V	230~		
	Frequency	Hz	50		
Starting Current		A	3.2	4.0	5.6

Model Name			AO * R14LC	AO * R18LC
Power Supply	Voltage	V	230~	
	Frequency	Hz	50	
Starting Current		A	6.4	7.7

10. SAFETY DEVICES

OUTDOOR UNIT
AO*R07-18LC

OUTDOOR UNIT
AO*R07-18LC

	Protection form	Model	
		AO * R07LC / AO * R09LC / AO * R12LC	AO * R14LC / AO * R18LC
Circuit protection	Current fuse (NEAR THE TERMINAL)	20A 250V	
	Current fuse (MAIN PRINTED CIRCUIT BOARD)	15A 250V	
		3.15A 250V	
Fan motor protection	Thermal protection program	OFF : 135^{+5}_{-5} °C ON : 95^{+15}_{-15} °C	OFF : 100^{+15}_{-10} °C ON : 95^{+15}_{-10} °C
Compressor protection	Thermal protection program (DISCHARGE TEMP.)	OFF : 110°C ON : After 7 minutes	