

**INDOOR UNIT**

**1. WALL MOUNTED TYPE :**

**AS \* A24LCC**

**AS \* A30LCC**

# 1. FEATURE

■ **MODEL :**  
AS\*A24LCC  
AS\*A30LCC

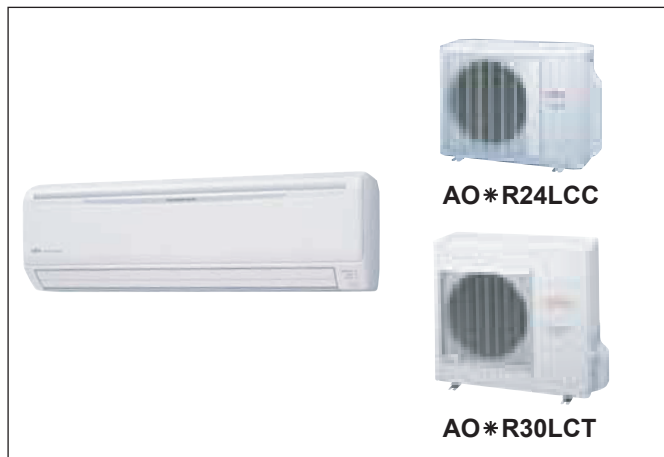

## ■ FEATURES

● **Energy saving Rank A (24TYPE)**  
Europe energy saving Rank A achieved

● **ALL DC**



Heat exchange capacities 20% up compared to conventional models



DC fan motor

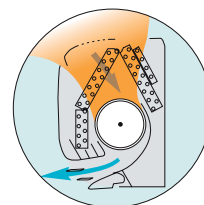

High efficiency layout

Large air flow and quiet operation by new air flow path

**a** DC fan motor

**b** V-PAM control  
V-PAM technology makes a compressor more powerful.

**c** DC scroll compressor  
More compact compared with conventional model

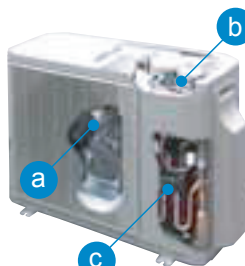

Front view

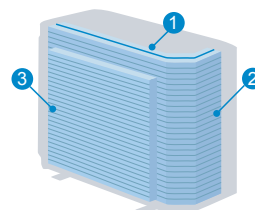

New 3-row heat exchange system

Back view

● **Super quiet**

Air flow mode can be set in 4 steps and more detailed air flow setting is possible.

● **Easy maintenance**

Easy maintenance and always clean. Troublesome maintenance has been made easy.  
Since the front panel is easy to remove, maintenance is also easy.

● **Inner drying operation**

This model is equipped with an inner drying function. After the power is turned off, the dry operation starts inside the air conditioner. This prevents the growth of mold and bacterial inside the air conditioner.

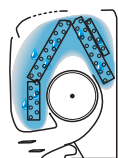

During dew condensation

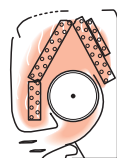

Approx. 20 mins Drying

## ● Power diffuser

Adoption of large power diffuser

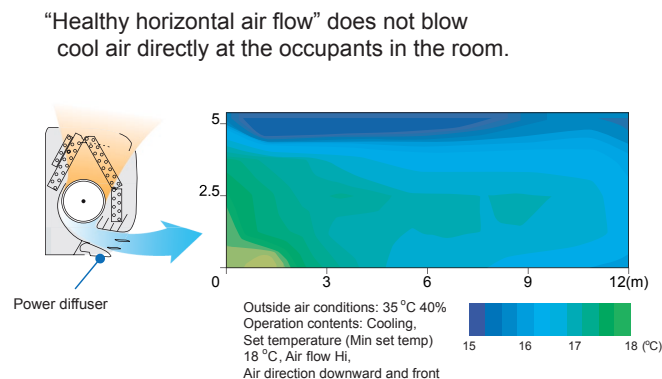
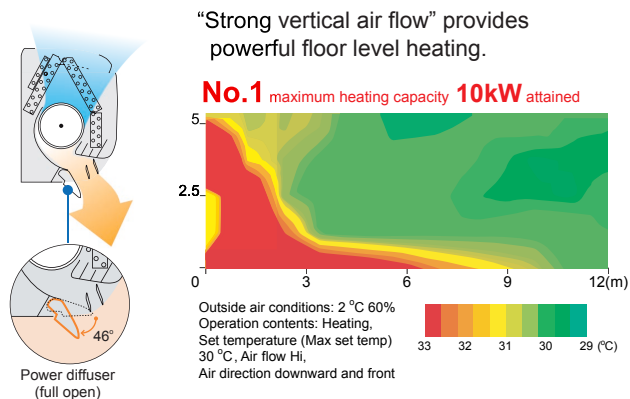

## ● Compact design

998mm width compact design

**New model**



H320 x W998 x D228

**Conventional model**



H320 x W1,120 x D220

(unit:mm)

## ● Low outdoor air temperature cooling correspondence

Corresponds to cooling operation at -10°C outdoor air temperature

## ● Corresponds to maximum 50m long piping (30TYPE)

## ● Air conditioner filter features

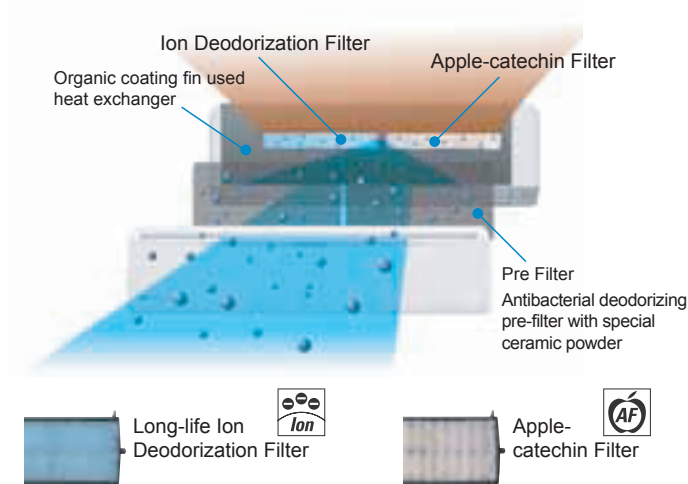

## 2. REMOTE CONTROLLER

### 2-1. WIRELESS REMOTE CONTROLLER

#### ■ FEATURES



- \* Four kinds of timer setup (ON / OFF / PROGRAM / SLEEP) are possible.
- \* Four kinds of timers. Easy operation.

#### ● Built-in timers

Select from four different timer programs (On/Off/Program/Sleep).

#### ● Program timer

The program timer operates the ON and OFF timer once within a 24 hour period.

#### ● Sleep timer

The sleep timer function automatically corrects the temperature thermostat setting according to the time setting to prevent excessive cooling and heating while sleeping.

##### Cooling operation/dry operation

When the sleep timer is set, the set temperature automatically rises  $1^{\circ}\text{C}$  every hour. The set temperature can rise up to a maximum of  $2^{\circ}\text{C}$ .

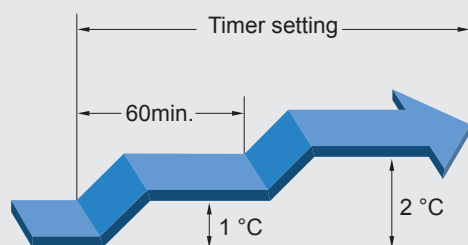

##### Heating operation

When the sleep timer is set, the set temperature automatically drops  $1^{\circ}\text{C}$  every 30 minutes. The set temperature can drop to a maximum of  $4^{\circ}\text{C}$ .

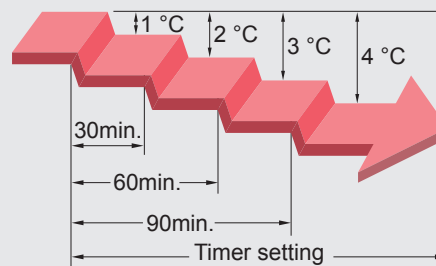

## FUNCTIONS

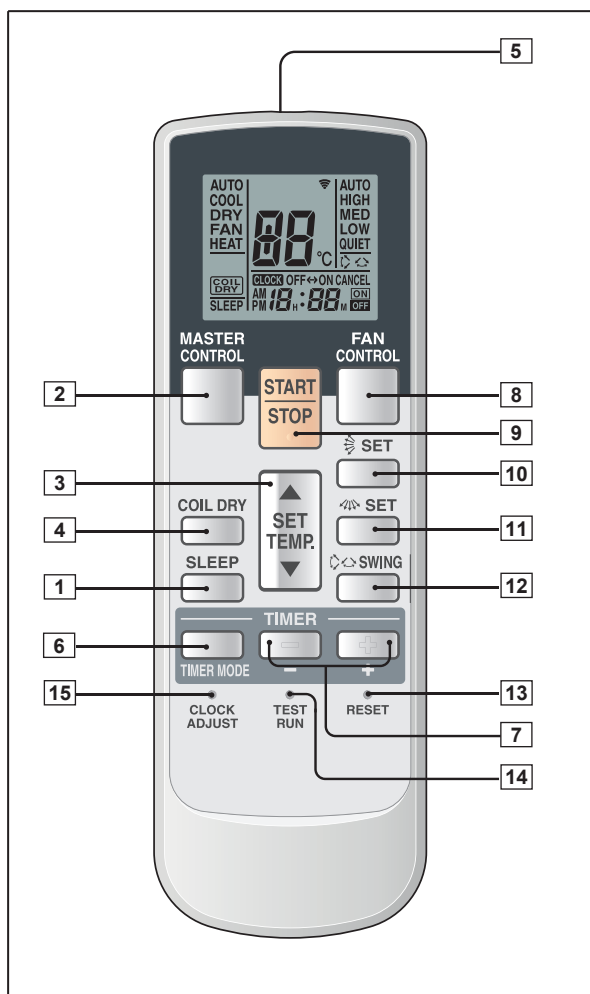

- 1 SLEEP button
- 2 MASTER CONTROL button
- 3 SET TEMP button ( ▲ / ▼ )
- 4 COIL DRY button
- 5 Signal Transmitter
- 6 TIMER MODE button
- 7 TIMER SET ( + / - ) button
- 8 FAN CONTROL button
- 9 START/STOP button
- 10 SET button (Vertical)
- 11 SET button (Horizontal)
- 12 SWING button
- 13 RESET button
- 14 TEST RUN button
  - This button is used when installing the conditioner, and should not be used under normal conditions, as it will cause the air conditioner's thermostat function to operate incorrectly.
  - If this button is pressed during normal operation, the unit will switch to test operation mode, and the Indoor Unit's OPERATION Indicator Lamp and TIMER Indicator Lamp will begin to flash simultaneously.
  - To stop the test operation mode, press the START/STOP button to stop the air conditioner.

### Display panel

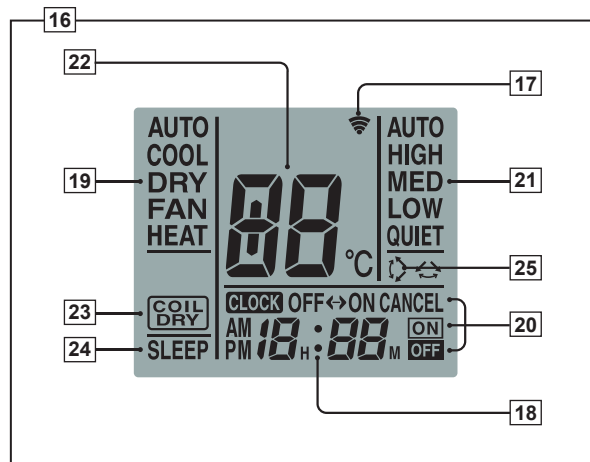

- 15 CLOCK ADJUST button
- 16 Remote Control Unit Display
- 17 Transmit Indicator
- 18 Clock Display
- 19 Operating Mode Display
- 20 Timer Mode Display
- 21 Fan Speed Display
- 22 Temperature SET Display
- 23 COIL DRY Display
- 24 SLEEP Display
- 25 SWING Display

## SPECIFICATION

SIZE (H x W x D mm)	176 x 56 x 18
WEIGHT (g)	110
ACCESSORY	Holder

## 3. SPECIFICATIONS

Type			WALL MOUNTED			
			INVERTER HEAT PUMP			
Model name			AS * A24LCC	AS * A30LCC		
Power source			230V~ 50Hz			
Available voltage range			198 - 264V~ 50Hz			
European energy label			Cooling	A	B	
			Heating	A	B	
Capacity	Cooling	Rated	kW	7.10	8.00	
			BTU/h	24,200	27,300	
		Min-Max	kW	0.9 - 8.0	2.9 - 9.0	
			BTU/h	3,100 - 27,300	9,900 - 30,700	
	Heating	Rated	kW	8.10	9.00	
			BTU/h	27,600	30,700	
Min-Max		kW	0.9 - 10.6	2.2 - 11.0		
		BTU/h	3,100 - 36,200	7,500 - 37,600		
Input power	Cooling	Rated	kW	2.21	2.66	
		Min-Max		0.11 - 2.62	0.58 - 3.60	
	Heating	Rated		2.24	2.64	
		Min-Max		0.11 - 3.68	0.50 - 4.30	
Current	Cooling	Rated	A	9.7	11.7	
		Max		12	17	
	Heating	Rated		9.8	11.6	
		Max		17.5	19	
EER			Cooling	kW/kW	3.21	3.01
COP			Heating		3.62	3.41
SENSIBLE CAPACITY			Cooling	kW	5.54	5.34
POWER FACTOR			Cooling	%	99	99
			Heating		99	99
Moisture removal			l/h (pints/h)	3.0 (5.3)	3.4 (6.0)	
Fan	Airflow rate	Cooling	High	m <sup>3</sup> /h	1100	1100
			Med		900	900
			Low		740	740
			Quiet		620	620
		Heating	High		1100	1100
			Med		900	900
			Low		740	740
			Quiet		620	620
	Type × Q'ty			Cross flow fan × 1		
	Motor output			W	42	42
Sound pressure level	Cooling	High	dB(A)	47	47	
		Med		41	41	
		Low		36	36	
		Quiet		32	32	
	Heating	High		45	45	
		Med		41	41	
		Low		36	36	
		Quiet		32	32	
Heat exchanger type	Dimensions (H × W × D)		mm	Main : 378 × 832 × 26.6 Sub : 84 × 832 × 13.3	Main : 378 × 832 × 26.6 Sub1 : 84 × 832 × 13.3, Sub2 : 84 × 832 × 13.3	
	Fin pitch			Main : 1.2, Sub : 1.4	Main : 1.2, Sub1 : 1.4, Sub2 : 1.4	
	Rows x Stages		Main : 2 × 18, Sub : 1 × 4	Main : 2 × 18, Sub : 1 × 4, Sub2 : 1 × 4		
	Pipe type		Copper			
	Fin type		Aluminium			
Enclosure			Material			Polystyrene
			Colour			White
Dimensions (H × W × D)	Net		mm	320 × 998 × 228		
	Gross			319 × 1090 × 429		
Weight	Net		kg(lb.)	14 (30.8)		
	Gross			18 (39.6)		
Connection pipe	Size	Liquid	mm	Φ 6.35 (Φ 1/4 in.)	Φ 9.52 (Φ 3/8 in.)	
		Gas		Φ 15.88 (Φ 5/8 in.)		
	Method			Flare		
Operation range	Cooling	°C	18 to 32			
		%RH	80 or less			
	Heating	°C	30 or less			
Remote controller type			Wireless			
Drain pipe	Material		PVC			
	Size		mm			Outer diameter : 28 / Inner diameter : 16

Note :  
Specifications are based on the following conditions.  
Cooling : Indoor temperature of 27°CDB/19°CWB. and outdoor temperature of 35°CDB/24°CWB.  
Heating : Indoor temperature of 20°CDB/15°CWB. and outdoor temperature of 7°CDB/6°CWB.  
Pipe length : 7.5 m, Height difference : 0 m.(Outdoor unit - Indoor unit)

# 4. DIMENSIONS

■ MODEL : AS\*A24LC, AS\*A30LC

(Unit : mm)

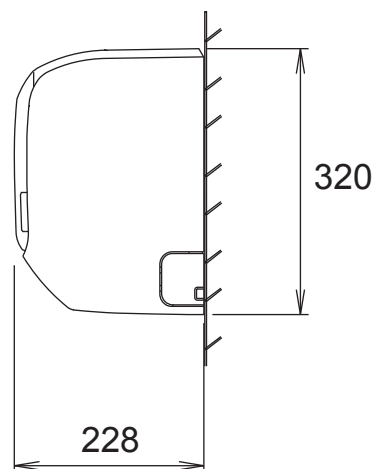
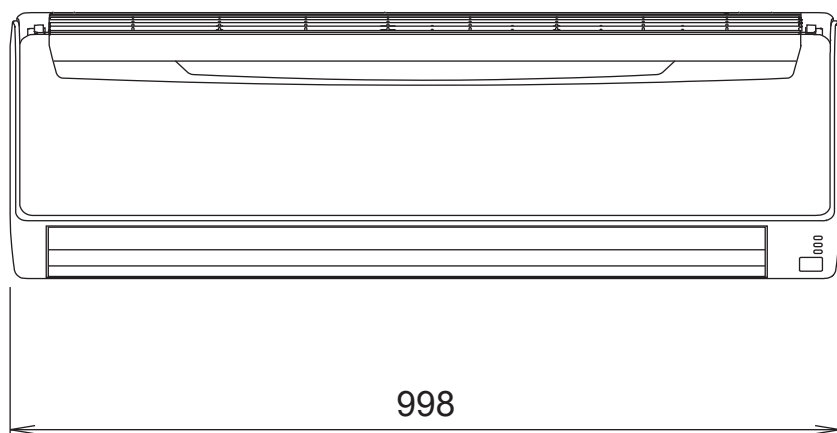

## ■ MOUNTING POSITION

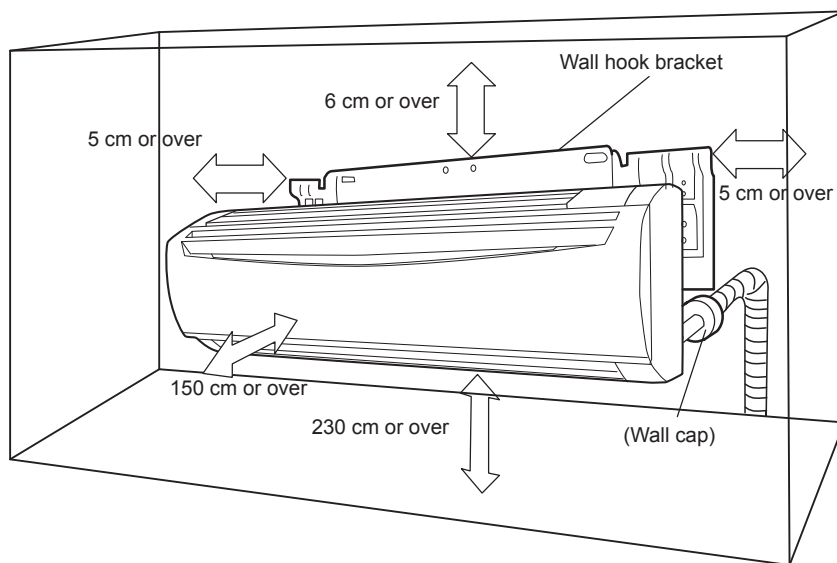

# 5. WIRING DIAGRAMS

■ MODEL : AS\*A24LC, AS\*A30LC

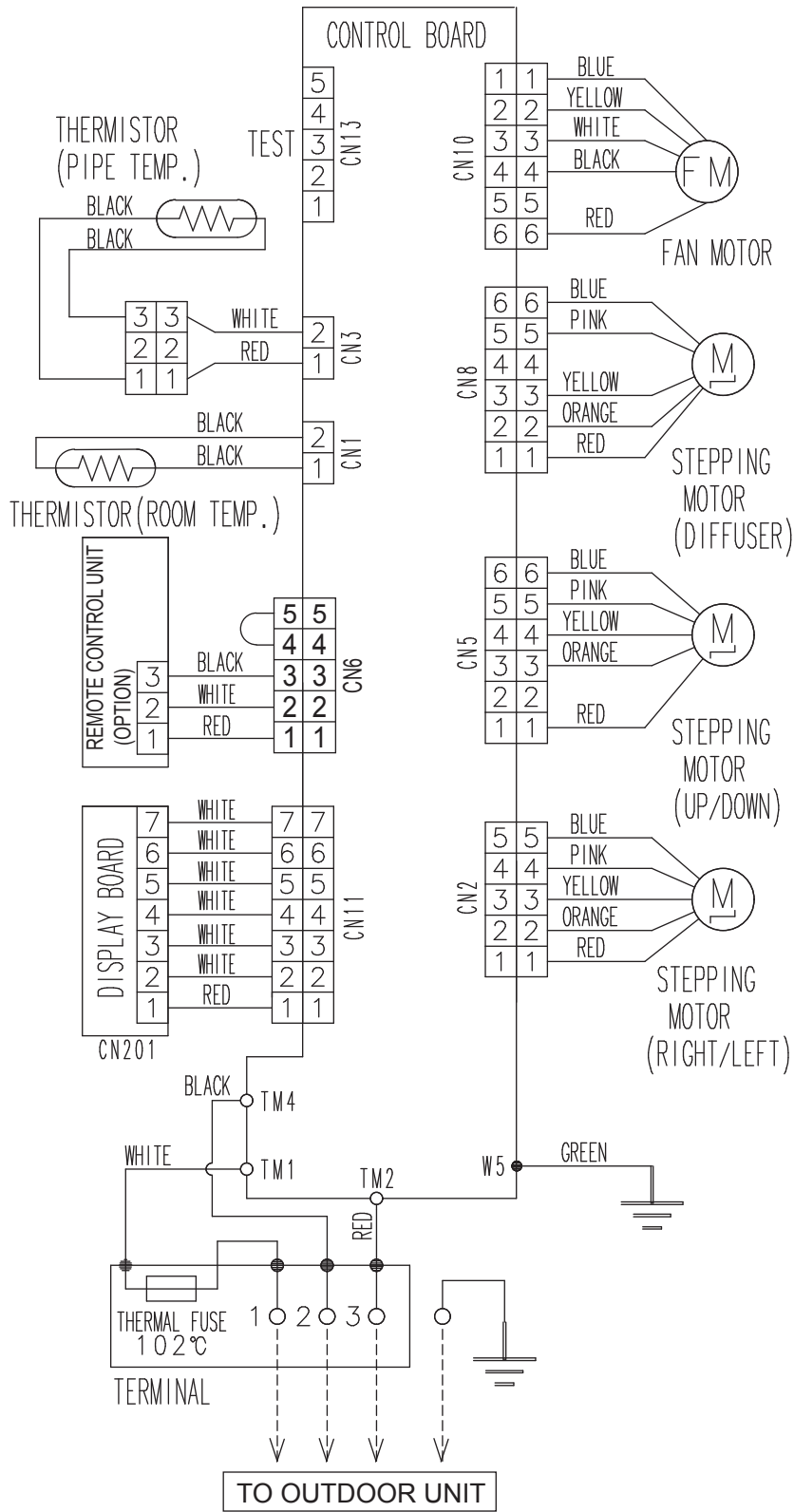



# 6. CAPACITY TABLE

## 6-1. COOLING CAPACITY

### ■ MODEL : AS \*A24LC

AFR	18.3
-----	------

		Indoor temperature																					
		18			21			23			25			27			29			32			
		°CDB			°CWB			°CDB			°CWB			°CDB			°CWB			°CDB			°CWB
Outdoor temperature	°CDB	TC	SHC	PI	TC	SHC	PI	TC	SHC	PI	TC	SHC	PI	TC	SHC	PI	TC	SHC	PI	TC	SHC	PI	
	20	5.26	4.97	1.05	5.86	5.00	1.07	6.06	5.43	1.07	6.46	5.45	1.09	6.66	5.88	1.09	7.05	5.86	1.10	7.45	6.24	1.11	
	25	6.26	5.61	1.75	6.98	5.64	1.78	7.22	6.13	1.79	7.69	6.15	1.80	7.93	6.65	1.81	8.41	6.62	1.83	8.88	7.05	1.85	
	30	6.00	5.21	1.94	6.68	5.24	1.97	6.91	5.70	1.98	7.36	5.71	2.00	7.59	6.17	2.01	8.05	6.15	2.03	8.50	6.55	2.05	
	35	5.61	4.67	2.13	6.25	4.70	2.17	6.46	5.11	2.18	6.89	5.13	2.20	7.10	5.54	2.21	7.53	5.51	2.23	7.95	5.87	2.25	
	40	5.06	4.08	2.15	5.64	4.10	2.18	5.83	4.46	2.19	6.22	4.47	2.21	6.41	4.83	2.22	6.79	4.81	2.25	7.18	5.13	2.27	
	43	4.73	3.72	2.16	5.27	3.74	2.20	5.45	4.07	2.21	5.81	4.08	2.23	5.99	4.41	2.24	6.35	4.39	2.27	6.71	4.67	2.29	

### ■ MODEL : AS \*A30LC

AFR	18.3
-----	------

		Indoor temperature																					
		18			21			23			25			27			29			32			
		°CDB			°CWB			°CDB			°CWB			°CDB			°CWB			°CDB			°CWB
Outdoor temperature	°CDB	TC	SHC	PI	TC	SHC	PI	TC	SHC	PI	TC	SHC	PI	TC	SHC	PI	TC	SHC	PI	TC	SHC	PI	
	20	6.31	4.51	1.33	7.03	4.53	1.35	7.27	4.93	1.36	7.75	4.94	1.37	7.99	5.34	1.38	8.47	5.32	1.39	8.95	5.66	1.41	
	25	7.00	4.86	2.09	7.79	4.89	2.12	8.06	5.31	2.13	8.59	5.33	2.15	8.85	5.75	2.16	9.39	5.73	2.19	9.92	6.10	2.21	
	30	6.66	4.68	2.32	7.42	4.70	2.36	7.67	5.11	2.37	8.18	5.13	2.39	8.43	5.54	2.41	8.94	5.52	2.43	9.44	5.88	2.45	
	35	6.32	4.51	2.57	7.04	4.54	2.61	7.28	4.93	2.62	7.76	4.95	2.65	8.00	5.34	2.66	8.48	5.32	2.69	8.96	5.67	2.71	
	40	5.68	4.20	2.77	6.33	4.23	2.82	6.55	4.60	2.83	6.98	4.61	2.86	7.19	4.98	2.87	7.63	4.96	2.90	8.06	5.29	2.93	
	43	5.34	4.04	2.80	5.95	4.07	2.84	6.15	4.42	2.85	6.56	4.44	2.88	6.76	4.79	2.90	7.16	4.77	2.93	7.57	5.08	2.96	

AFR : Air flow rate (m<sup>3</sup>/min)  
 TC : Total capacity (kW)  
 SHC : Sensible Heat capacity (kW)  
 PI : Power Input (kW)

## 6-2. HEATING CAPACITY

### ■ MODEL : AS \*A24LC

AFR | 18.3

		Indoor temperature										
		°CDB	°CWB	16		18		20		22		24
Outdoor temperature	°CDB	°CWB	TC	PI	TC	PI	TC	PI	TC	PI	TC	PI
	-15	-16	5.93	2.69	5.78	2.74	5.64	2.80	5.50	2.85	5.36	2.91
	-10	-11	7.04	2.94	6.87	3.00	6.70	3.06	6.53	3.12	6.37	3.18
	-5	-7	7.92	3.09	7.73	3.15	7.54	3.22	7.36	3.28	7.17	3.34
	0	-2	9.15	3.30	8.94	3.37	8.72	3.43	8.50	3.50	8.28	3.57
	5	3	10.41	3.52	10.16	3.59	9.91	3.67	9.67	3.74	9.42	3.81
	7	6	11.13	3.42	10.87	3.49	10.60	3.56	10.34	3.63	10.07	3.70
	10	8	11.53	3.42	11.25	3.49	10.98	3.56	10.71	3.64	10.43	3.71
15	10	11.16	2.97	10.90	3.04	10.63	3.10	10.37	3.16	10.10	3.22	

### ■ MODEL : AS \*A30LC

AFR | 18.3

		Indoor temperature										
		°CDB	°CWB	16		18		20		22		24
Outdoor temperature	°CDB	°CWB	TC	PI	TC	PI	TC	PI	TC	PI	TC	PI
	-15	-16	7.74	4.07	7.56	4.16	7.38	4.24	7.19	4.33	7.01	4.41
	-10	-11	8.34	4.06	8.14	4.15	7.94	4.23	7.74	4.32	7.54	4.40
	-5	-7	9.61	4.08	9.38	4.17	9.15	4.25	8.93	4.34	8.70	4.42
	0	-2	10.54	4.04	10.29	4.13	10.04	4.21	9.79	4.30	9.54	4.38
	5	3	11.53	4.09	11.26	4.18	10.98	4.26	10.71	4.35	10.43	4.43
	7	6	11.55	3.39	11.28	3.46	11.00	3.53	10.73	3.60	10.45	3.67
	10	8	11.90	3.38	11.62	3.45	11.33	3.52	11.05	3.59	10.77	3.66
15	10	11.48	2.95	11.20	3.01	10.93	3.07	10.66	3.13	10.38	3.20	

AFR : Air flow rate (m<sup>3</sup>/min)  
 TC : Total capacity (kW)  
 PI : Power Input (kW)

# 7. FAN PERFORMANCE

## 7-1. AIR VELOCITY DISTRIBUTION

■ MODEL : AS\*A24LC, AS\*A30LC

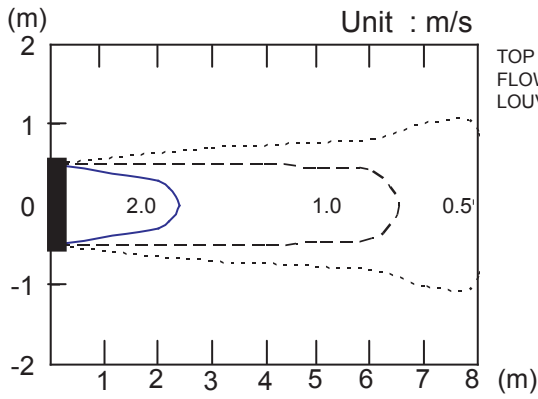

Note :  
Fan speed : High  
Operation mode : FAN  
Voltage : 230V

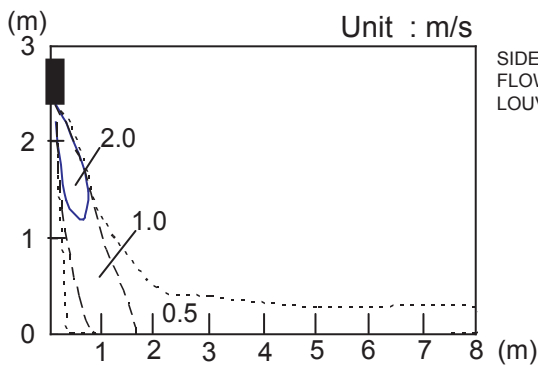
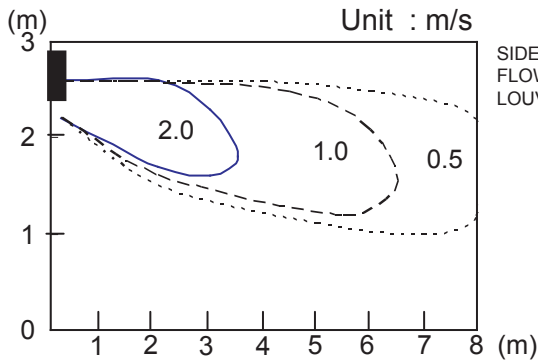
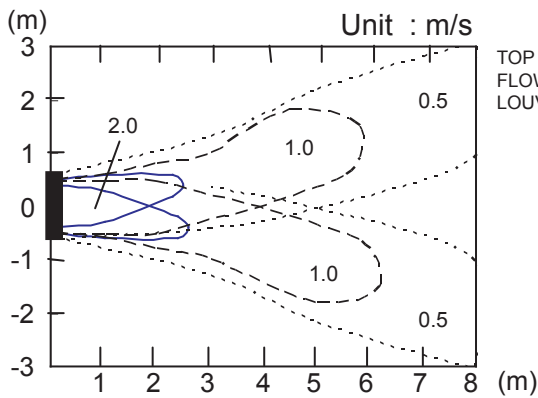

## 7-2. AIR FLOW

### ■ MODEL : AS \*A24LC

#### ● COOLING

Fan speed	Number of rotations (r.p.m)	Air flow	
		m <sup>3</sup> /h	l/s
HIGH	1310	m <sup>3</sup> /h	1100
		l/s	306
		CFM	647
MED	1120	m <sup>3</sup> /h	900
		l/s	250
		CFM	530
LOW	940	m <sup>3</sup> /h	740
		l/s	206
		CFM	435
QUIET	830	m <sup>3</sup> /h	620
		l/s	172
		CFM	365

#### ● HEATING

Fan speed	Number of rotations (r.p.m)	Air flow	
		m <sup>3</sup> /h	l/s
HIGH	1310	m <sup>3</sup> /h	1100
		l/s	306
		CFM	647
MED	1120	m <sup>3</sup> /h	900
		l/s	250
		CFM	530
LOW	940	m <sup>3</sup> /h	740
		l/s	206
		CFM	435
QUIET	830	m <sup>3</sup> /h	620
		l/s	172
		CFM	365

## ■ MODEL : AS \*A30LC

### ● COOLING

Fan speed	Number of rotations (r.p.m)	Air flow	
		m <sup>3</sup> /h	l/s
HIGH	1330	1100	306
		647	178
		CFM	647
MED	1120	900	250
		530	150
		CFM	530
LOW	940	740	206
		435	122
		CFM	435
QUIET	830	620	172
		365	103
		CFM	365

### ● HEATING

Fan speed	Number of rotations (r.p.m)	Air flow	
		m <sup>3</sup> /h	l/s
HIGH	1330	1100	306
		647	178
		CFM	647
MED	1120	900	250
		530	150
		CFM	530
LOW	940	740	206
		435	122
		CFM	435
QUIET	830	620	172
		365	103
		CFM	365

# 8. OPERATION NOISE

## 8-1. NOISE LEVEL CURVE

### ■ COOLING

● MODEL : AS \*A24LC

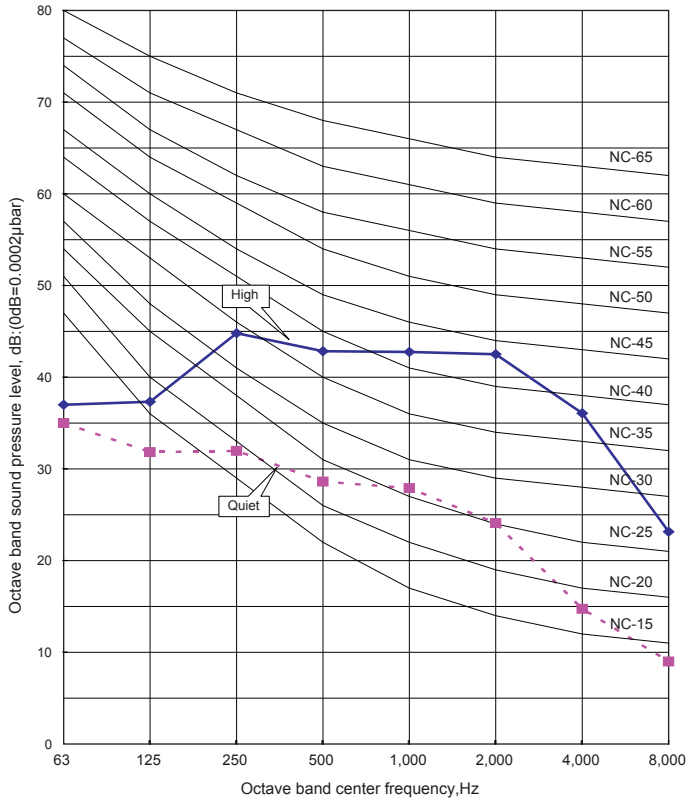

● MODEL : AS \*A30LC

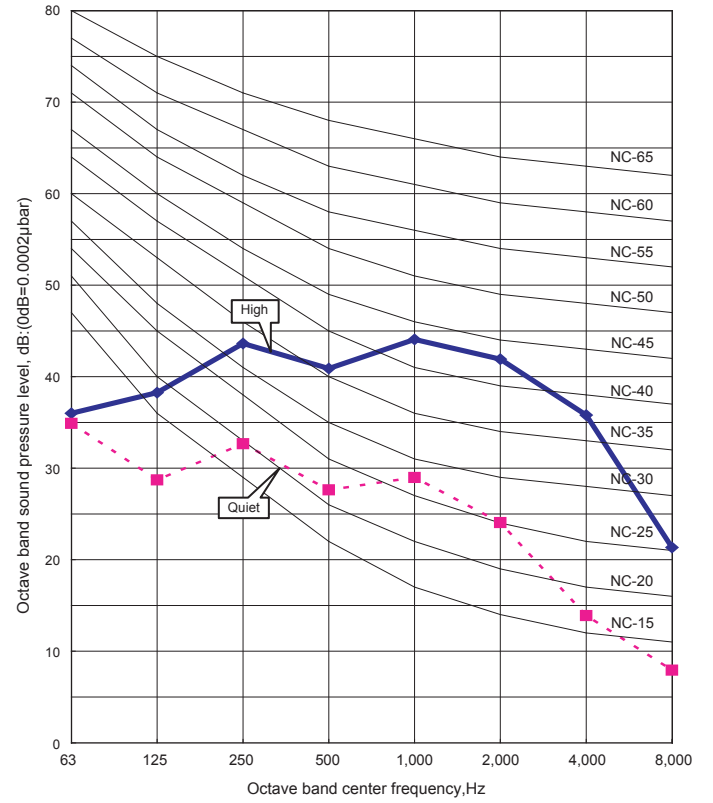

### ■ HEATING

● MODEL : AS \*A24LC

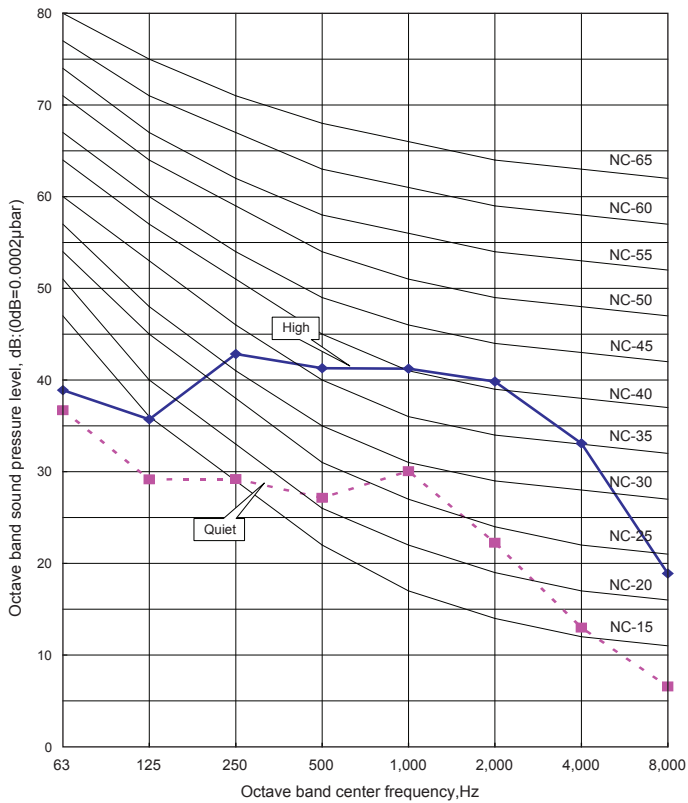

● MODEL : AS \*A30LC

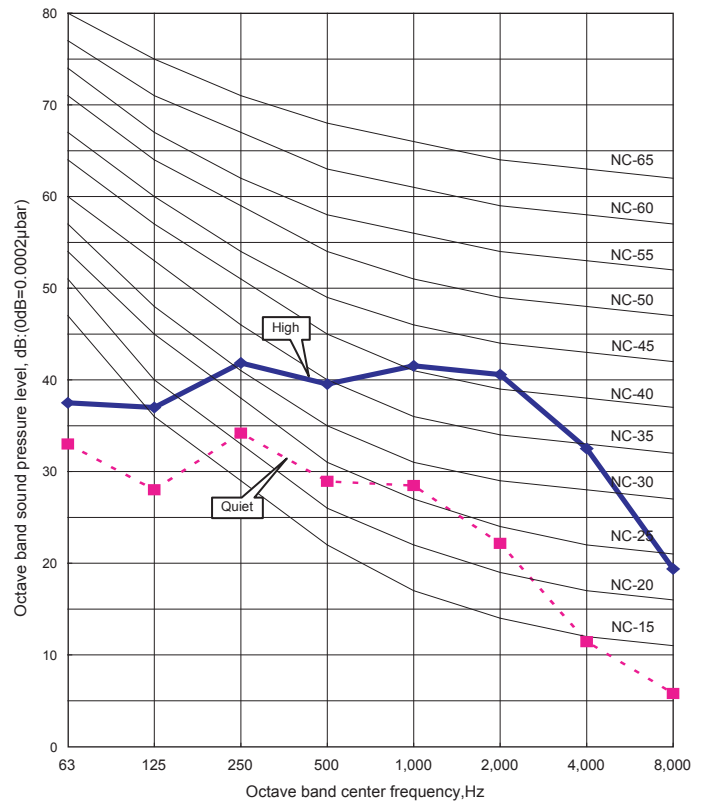

## 8-2. SOUND LEVEL CHECK POINT

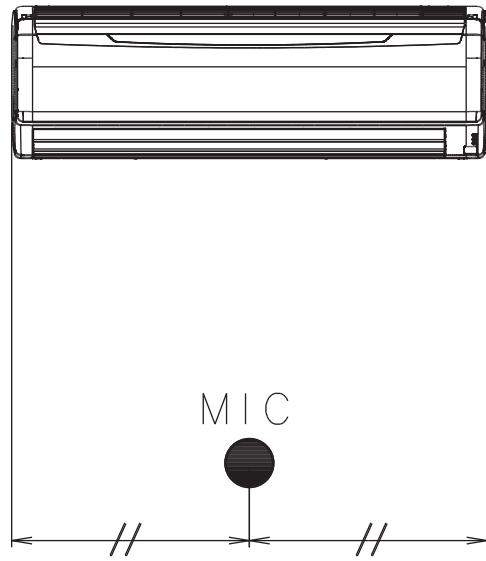
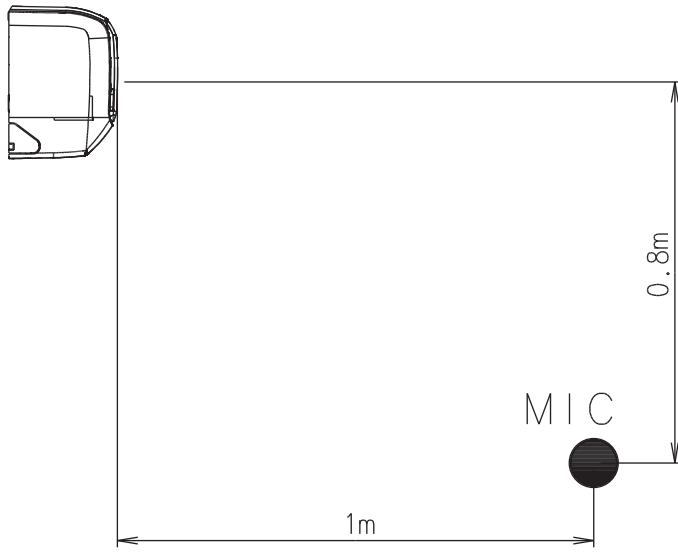

## 9. ELECTRIC CHARACTERISTICS

Model Name			AS * A24LC	AS * A30LC
Power Supply	Voltage	V	230~	
	Frequency	Hz	50	
Max Operating Current		A	0.3	0.3
*1)Wiring Spec.	Circuit breaker	A	0.4	0.4
	Connection Cable	mm <sup>2</sup>	1.5 - 2.5	1.5 - 2.5
	Limited wiring length	m	31	51

\*1) Wiring Spec.

Selected Sample



(Selected based on Japan Electrotechnical Standard and Codes Committee E0005)



## 10. SAFETY DEVICES

	Protection form	Model	
		AS * A24LC	AS * A30LC
Circuit protection	Current fuse (PCB)	3.15A 250V	
Terminal protection	Current fuse	3A 250V	
Fan motor protection	Thermal protection program	100 <sup>+15</sup> <sub>-10</sub> °C OFF 95 <sup>+5</sup> <sub>-10</sub> °C ON	

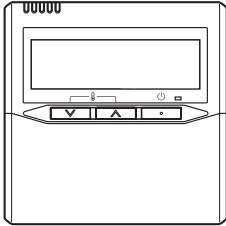
# 11. OPTIONAL PARTS

Exterior	Parts name	Model No.	Summary
	Wired remote controller	UTH-3TA16	Unit control is performed by <b>wired remote controller</b>
	Apple-catechin filter	UTR-FA13-1	Fine dust, invisible mold spores, and harmful microorganisms are absorbed onto the filter by <b>static electricity</b> , and further growth is inhibited and deactivated by the polyphenol ingredient extracted from apples.
	Ion deodorisation filter	UTR-FA13-2	The filter deodorizes by powerfully decomposing absorbed odors using the oxidizing and reducing effects of ions generated by the ultra fine-particle ceramic.

# 11-1. WIRED REMOTE CONTROLLER

## FUNCTIONS

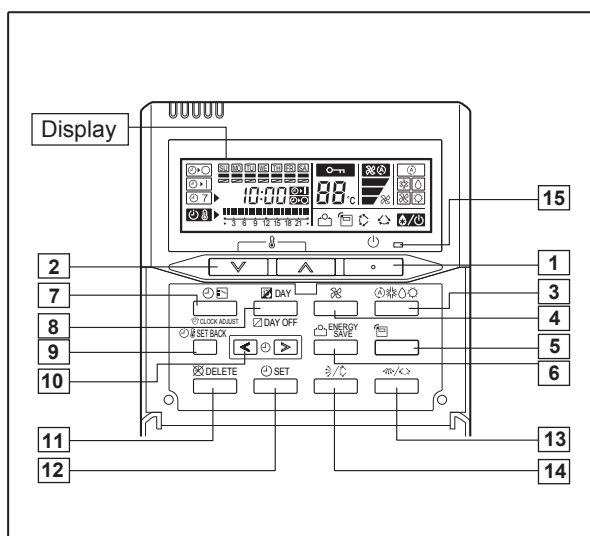

- 1 Start/Stop Button
- 2 Set Temperature Button
- 3 Master Control Button
- 4 Fan Control Button
- 5 THERMO SENSOR Button
- 6 ENERGY SAVE Button
- 7 Timer Mode (CLOCK ADJUST) Button
- 8 DAY (DAY OFF) Button
- 9 SET BACK Button
- 10 Set Time Button
- 11 DELETE Button
- 12 SET Button
- 13 Horizontal airflow direction and swing Button
- 14 Vertical airflow direction and swing Button
- 15 Operation Lamp

\* 1)

Display panel

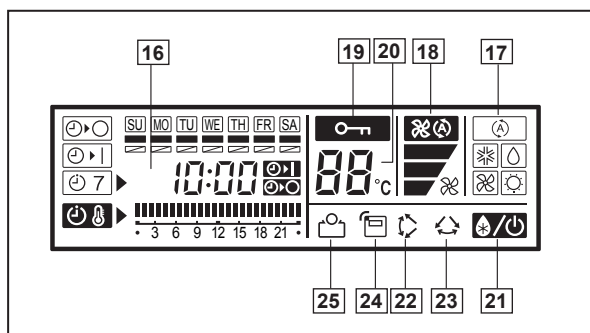

- 16 Timer and Clock Display
- 17 Operation Mode Display
- 18 Fan Speed Display
- 19 Operation Lock Display
- 20 Temperature Display
- 21 Defrost Display
- 22 Vertical Swing Display
- 23 Horizontal Swing Display
- 24 Thermo Sensor Display
- 25 Energy Save Display

## DIMENSION

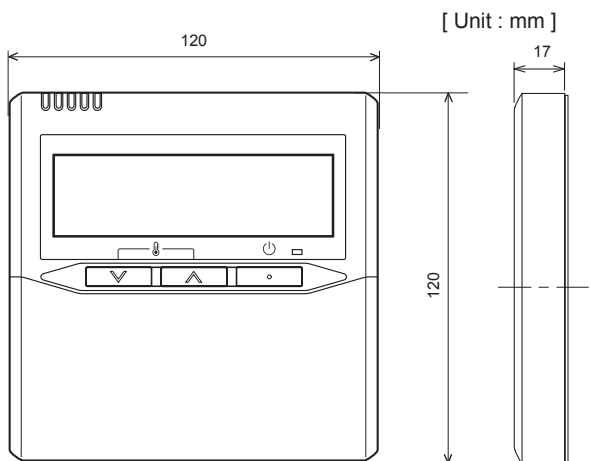

Front View

\* 1) Button number 5 and 6 cannot be operated.

## SPECIFICATION

SIZE (H x W x D mm)	120 x 120 x 17
WEIGHT (g)	160
CABLE LENGTH (m)	10
POWER (V)	12

## **OUTDOOR UNIT**

### **2. SINGLE TYPE :**

**AO \* R24LCC**

**AO \* R30LCT**

# 1. SPECIFICATIONS

OUTDOOR UNIT  
AO\*R24-30LC

OUTDOOR UNIT  
AO\*R24-30LC

Type			INVERTER HEAT PUMP		
Model name			AO * R24LCC	AO * R30LCT	
Power source			230V~ 50Hz		
Available voltage range			198 - 264V~ 50Hz		
Starting current			A		
Fan	Airflow rate	Cooling	9.8	11.7	
		Heating	2,340	3,600	
	Type × Q'ty		m <sup>3</sup> /h	2,470	3,800
	Motor output		W	65	100
Sound pressure level	Cooling		dB(A)	52	53
	Heating			53	55
Heat exchanger type	Dimensions (H × W × D)		mm	Main : 546 × 866 × 36.4, Sub : 504 × 589 × 18.2	798 × 900 × 36.4
	Fin pitch			Main : 1.4, Sub : 1.4	1.3
	Rows x Stages			Main : 2 × 26, Sub : 1 × 24	2 × 38
	Pipe type			Copper	
	Fin type			Aluminium	
Compressor	Type × Q'ty			Scroll × 1	Rotary × 1
	Motor output		W	1,200	1,700
Refrigerant	Type		R410A		
	Charge	g	1,600	2,100	
Refrigerant oil	Type		PVE (FV50S)		
Enclosure	Material		Steel		
	Colour		Beige		
Dimensions (H × W × D)	Net		mm	578 × 790 × 315	830 × 900 × 330
	Gross			648 × 910 × 380	970 × 1050 × 445
Weight	Net		kg(lb.)	44 (97)	62 (137)
	Gross			48 (105.8)	70 (154)
Connection pipe	Size	Liquid	mm	Φ6.35 (Φ 1/4 in.)	Φ9.52 (Φ 3/8 in.)
		Gas		Φ 15.88 (Φ 5/8 in.)	Φ 15.88 (Φ 5/8 in.)
	Method		Flare		
	Max. length		m	30 (chargeless : 15)	50 (chargeless : 20)
Max. height difference		20		30	
Operation range	Cooling		°C		-10 to 43
	Heating		-15 to 24		

**Note :**

Specifications are based on the following conditions.

Cooling : Indoor temperature of 27°CDB/19°CWB. and outdoor temperature of 35°CDB/24°CWB.

Heating : Indoor temperature of 20°CDB/15°CWB. and outdoor temperature of 7°CDB/6°CWB.

Pipe length : 7.5 m, Height difference : 0 m. (Outdoor unit - Indoor unit)

## 2. DIMENSIONS

### ■ MODEL : AO \*R24LC

(Unit : mm)

OUTDOOR UNIT  
AO\*R24-30LC

OUTDOOR UNIT  
AO\*R24-30LC

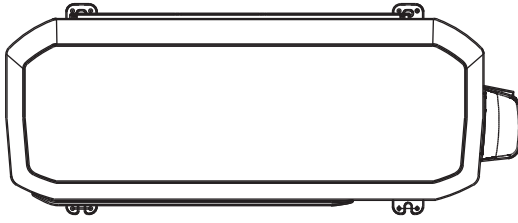

Top view

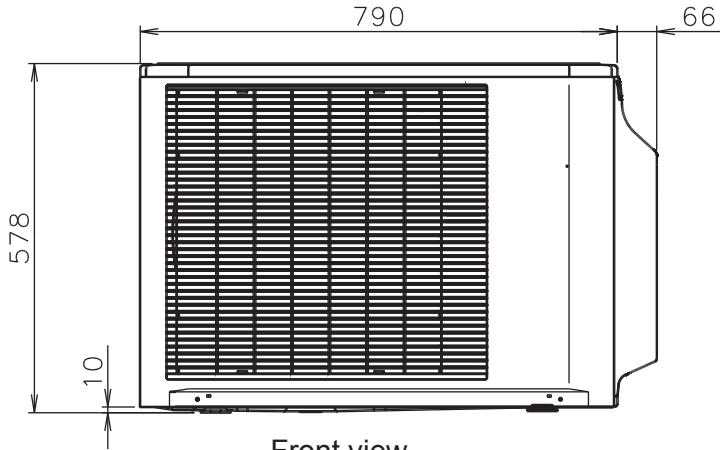

Front view

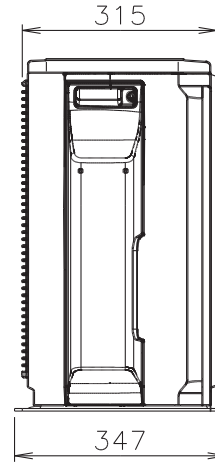

Side view

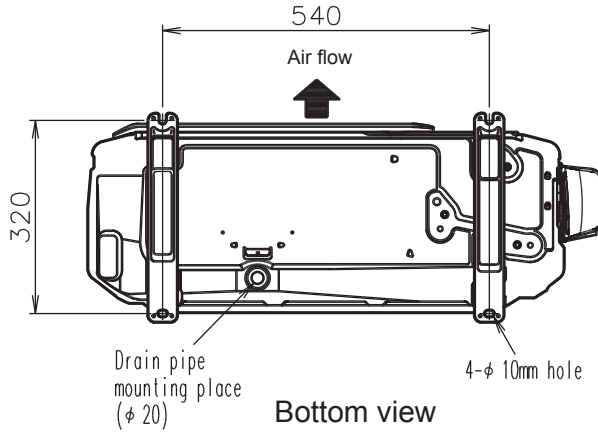

Bottom view

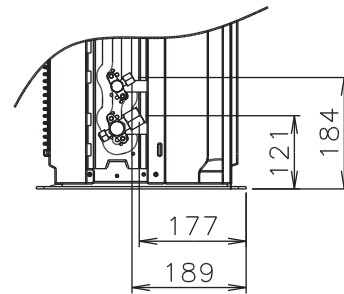

### ■ MOUNTING POSITION

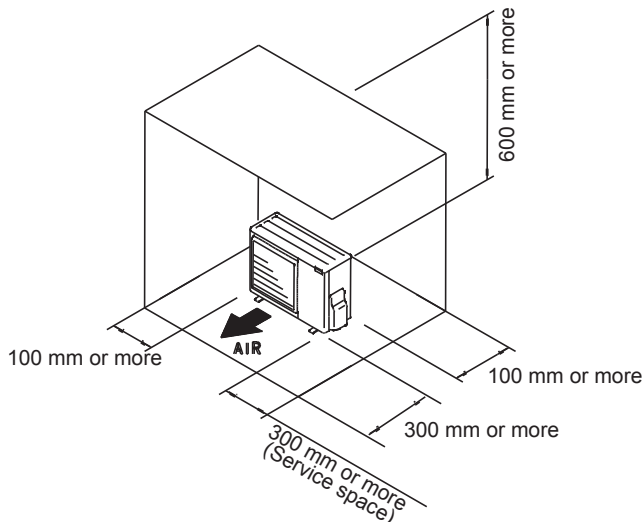

If the space is larger than that is stated, the condition will be the same as that are no obstacles.

# MODEL : AO \*R30LC

(Unit : mm)

OUTDOOR UNIT  
AO\*R24-30LC

OUTDOOR UNIT  
AO\*R24-30LC

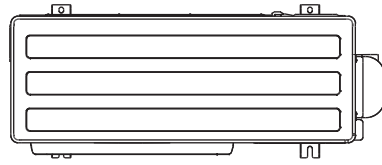

Top view

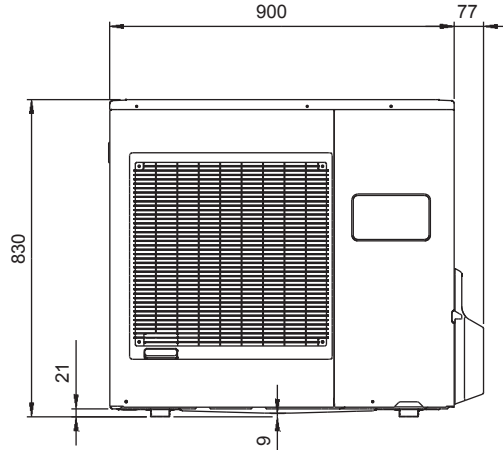

Front view

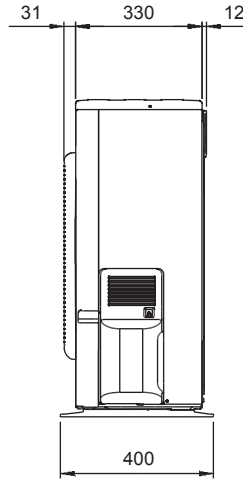

Side view

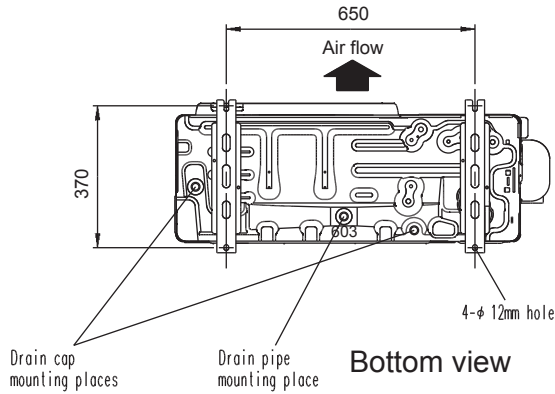

Bottom view

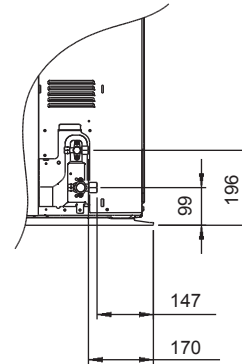

## MOUNTING POSITION

When there are obstacles at the back or front sides.

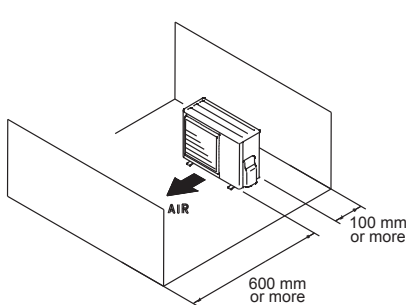

When there are obstacles at the back, side(s), and top.

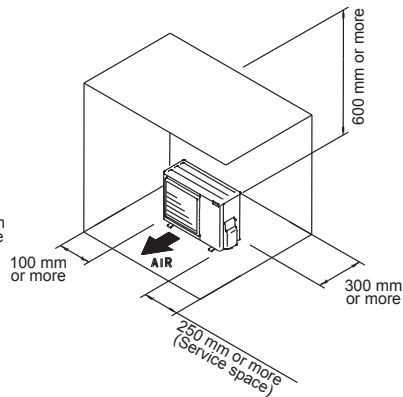

When there are obstacles at the back, side with the installation of more than one unit.

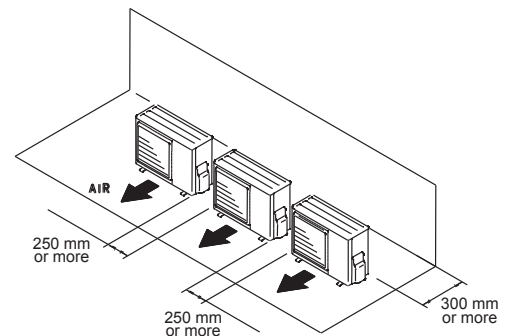

### 3. REFRIGERANT CIRCUIT

■ MODEL : AO\*R24LC

OUTDOOR UNIT  
AO\*R24-30LC

OUTDOOR UNIT  
AO\*R24-30LC

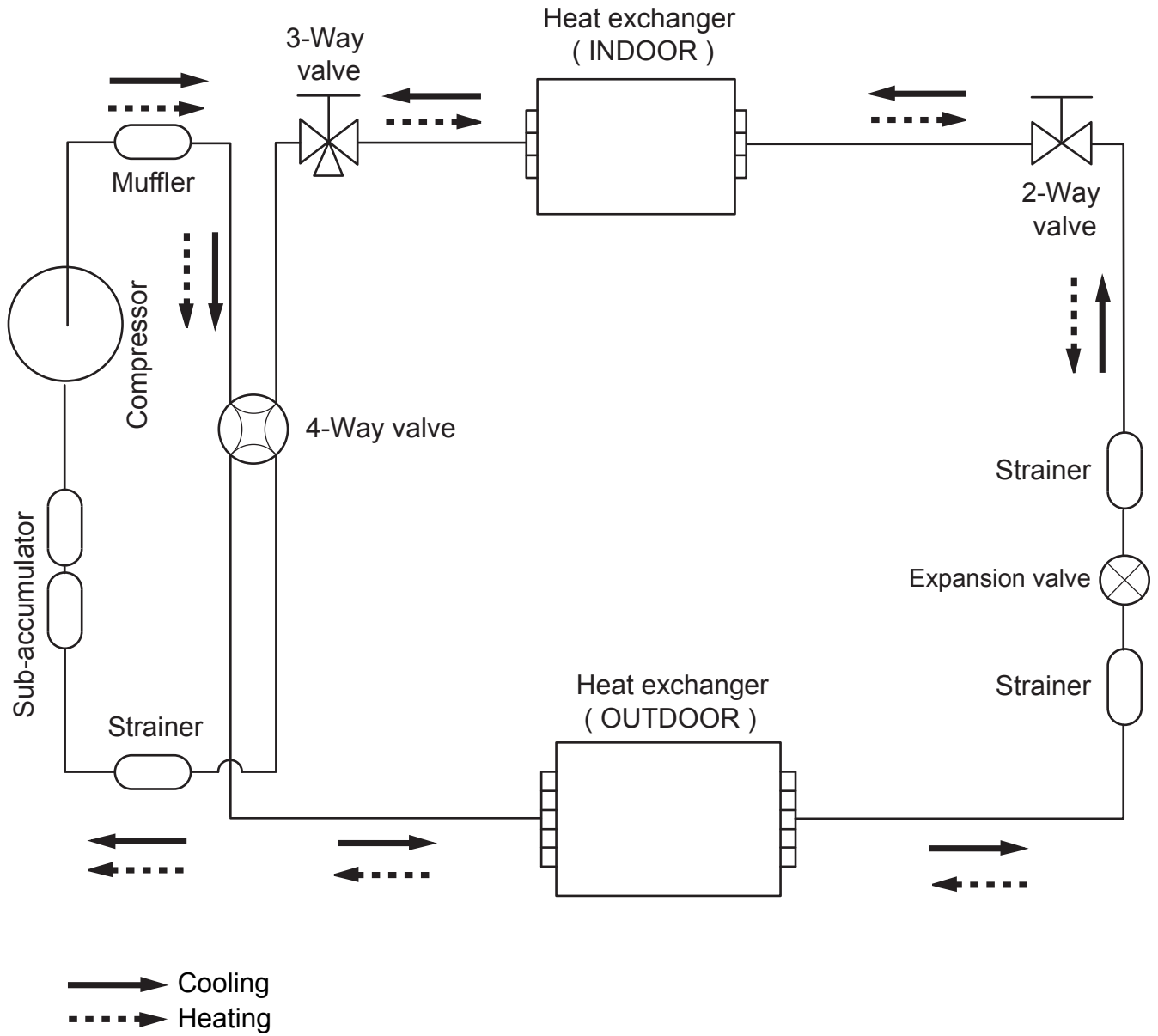

Refrigerant pipe diameter  
 Liquid : 1/4" (6.35 mm)  
 Gas : 5/8" (15.88 mm)



■ MODEL : AO\*R30LC

OUTDOOR UNIT  
AO\*R24-30LC

OUTDOOR UNIT  
AO\*R24-30LC

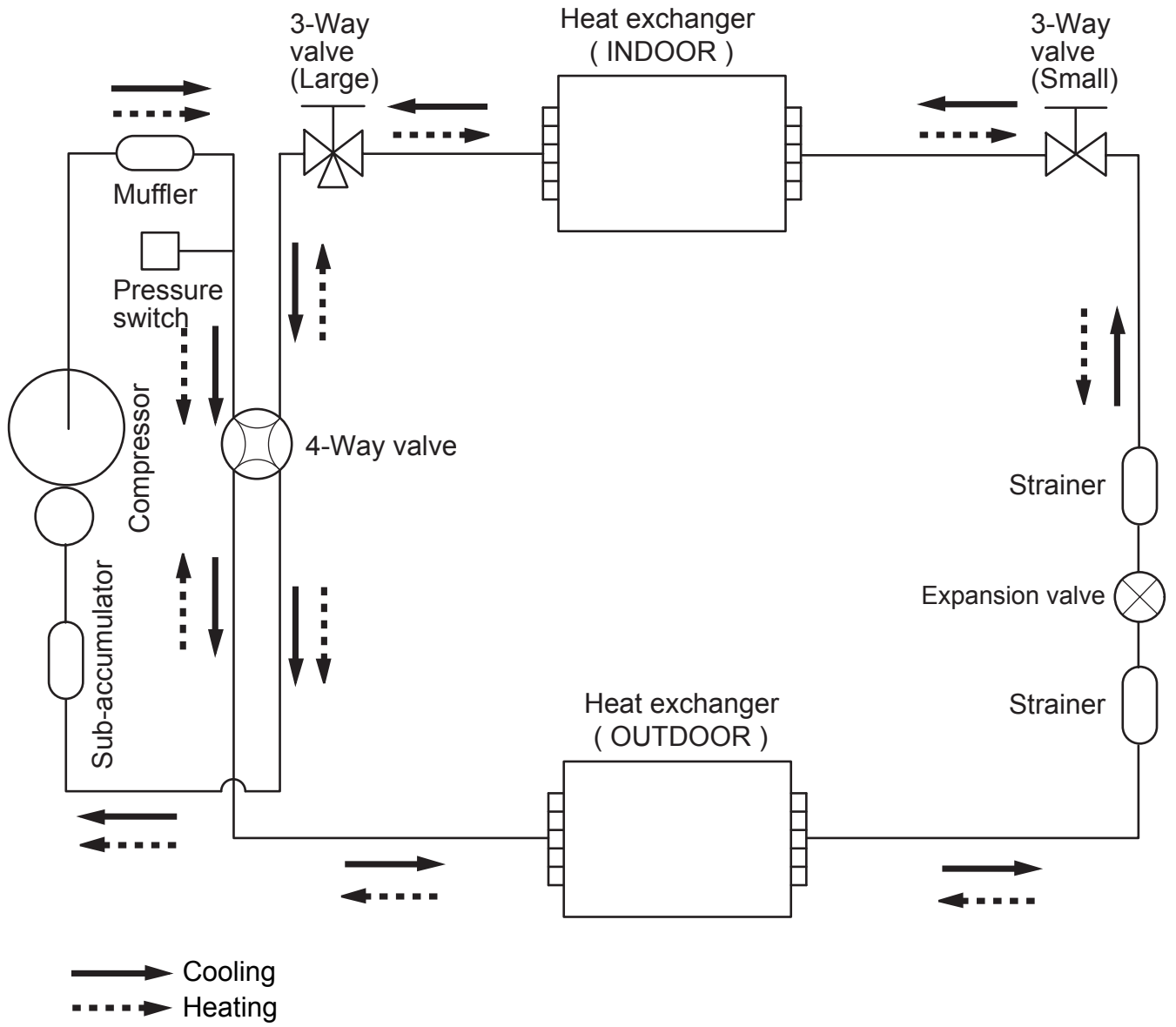

 Cooling  
 Heating

Refrigerant pipe diameter  
 Liquid : 3/8" (9.52 mm)  
 Gas : 5/8" (15.88 mm)

# 4. WIRING DIAGRAMS

## ■ MODEL : AO\*R24LC

OUTDOOR UNIT  
AO\*R24-30LC

OUTDOOR UNIT  
AO\*R24-30LC

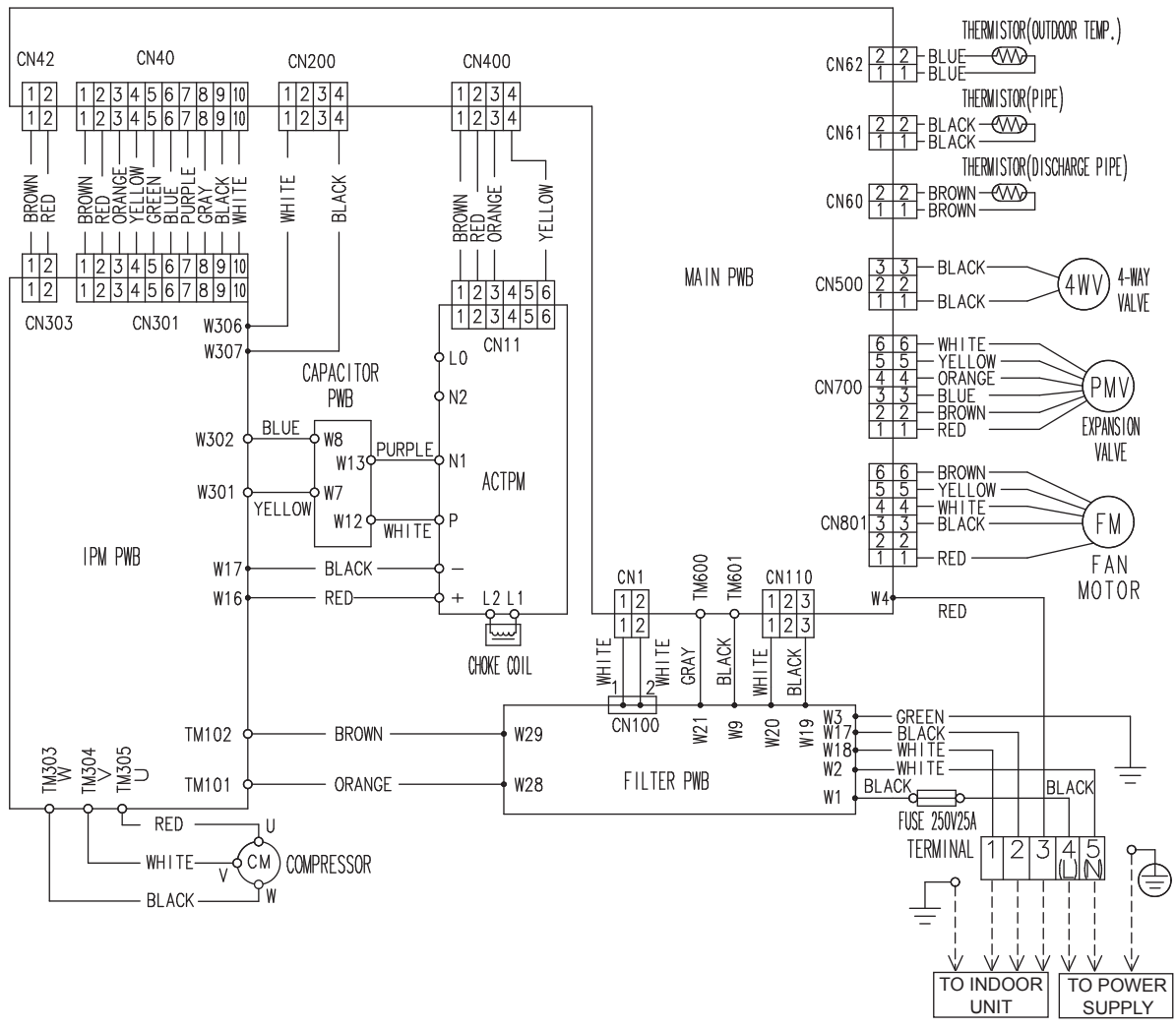

# MODEL : AO\*R30LC

OUTDOOR UNIT  
AO\*R24-30LC

OUTDOOR UNIT  
AO\*R24-30LC

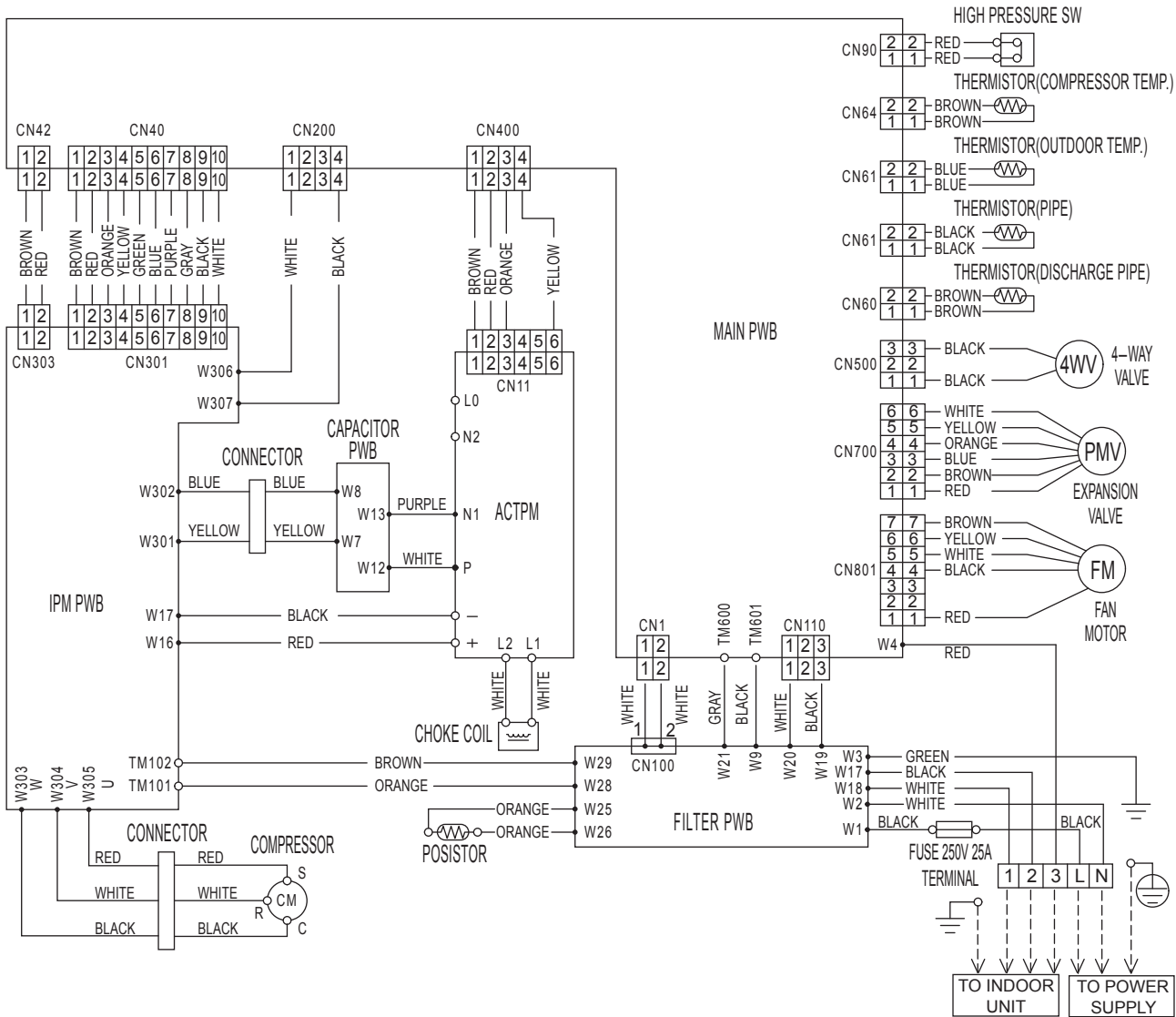

# 5. COEFFICIENT OF COMPENSATION FOR PIPE LENGTH AND HEIGHT DIFFERENCE

## MODEL : AO \* R24LC

OUTDOOR UNIT  
AO \* R24-30LC

OUTDOOR UNIT  
AO \* R24-30LC

COOLING			Pipe length (m)						
			5	7.5	10	15	20	25	30
Height difference H (m)	*1 Indoor unit is upper than outdoor unit.	20	-	-	-	0.951	0.952	0.951	0.951
		10	-	-	0.980	0.966	0.968	0.967	0.966
		7.5	-	0.988	0.984	0.970	0.972	0.971	0.970
		5	0.995	0.992	0.988	0.974	0.976	0.975	0.974
	0		1.003	1.000	0.996	0.982	0.983	0.983	0.982
	*2 Indoor unit is under than outdoor unit	-5	1.003	1.000	0.996	0.982	0.983	0.983	0.982
		-7.5	-	1.000	0.996	0.982	0.983	0.983	0.982
		-10	-	-	0.996	0.982	0.983	0.983	0.982
-20		-	-	-	0.982	0.983	0.983	0.982	

HEATING			Pipe length (m)						
			5	7.5	10	15	20	25	30
Height difference H (m)	*1 Indoor unit is upper than outdoor unit.	20	-	-	-	0.975	0.954	0.932	0.908
		10	-	-	0.998	0.975	0.954	0.932	0.908
		7.5	-	1.000	0.998	0.975	0.954	0.932	0.908
		5	0.989	1.000	0.998	0.975	0.954	0.932	0.908
	0		0.989	1.000	0.998	0.975	0.954	0.932	0.908
	*2 Indoor unit is under than outdoor unit	-5	0.984	0.995	0.993	0.970	0.950	0.927	0.903
		-7.5	-	0.993	0.991	0.968	0.947	0.925	0.901
		-10	-	-	0.988	0.965	0.945	0.923	0.899
-20		-	-	-	0.956	0.935	0.914	0.890	

Height difference H

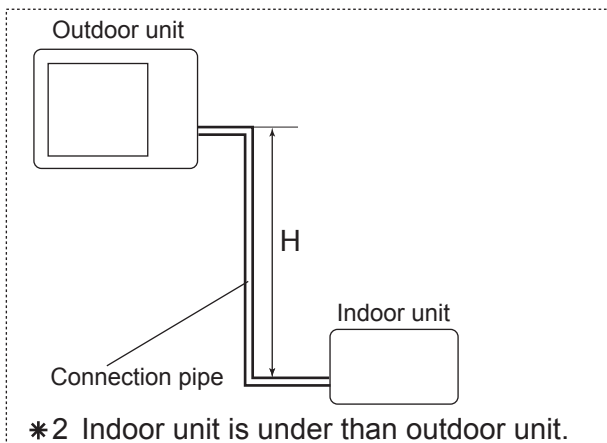
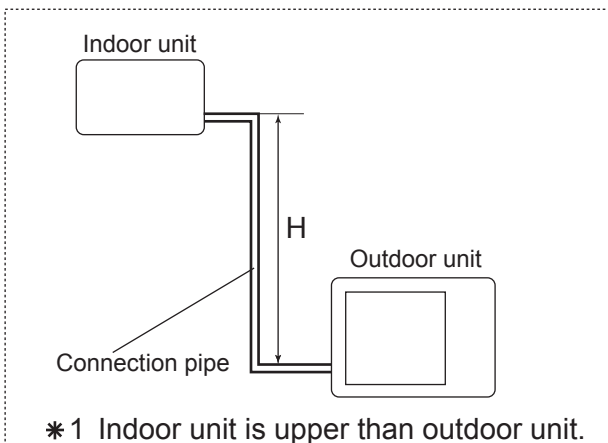

■ MODEL : AO \*R30LC

OUTDOOR UNIT  
AO\*R24-30LC

OUTDOOR UNIT  
AO\*R24-30LC

COOLING			Pipe length (m)						
			5	7.5	10	20	30	40	50
Height difference H (m)	*1 Indoor unit is upper than outdoor unit.	20	-	-	-	0.945	0.947	0.945	0.940
		10	-	-	0.984	0.961	0.963	0.960	0.956
		7.5	-	0.988	0.988	0.965	0.967	0.964	0.959
		5	0.990	0.992	0.992	0.968	0.971	0.968	0.963
	0		0.998	1.000	1.000	0.976	0.979	0.976	0.971
	*2 Indoor unit is under than outdoor unit	-5	0.998	1.000	1.000	0.976	0.979	0.976	0.971
		-7.5	-	1.000	1.000	0.976	0.979	0.976	0.971
		-10	-	-	1.000	0.976	0.979	0.976	0.971
-20		-	-	-	0.976	0.979	0.976	0.971	

HEATING			Pipe length (m)						
			5	7.5	10	20	30	40	50
Height difference H (m)	*1 Indoor unit is upper than outdoor unit.	20	-	-	-	0.872	0.816	0.756	0.686
		10	-	-	0.991	0.872	0.816	0.756	0.686
		7.5	-	1.000	0.991	0.872	0.816	0.756	0.686
		5	0.986	1.000	0.991	0.872	0.816	0.756	0.686
	0		0.986	1.000	0.991	0.872	0.816	0.756	0.686
	*2 Indoor unit is under than outdoor unit	-5	0.981	0.995	0.986	0.868	0.812	0.752	0.683
		-7.5	-	0.993	0.983	0.866	0.810	0.750	0.681
		-10	-	-	0.981	0.864	0.808	0.748	0.679
-20		-	-	-	0.855	0.799	0.740	0.672	

Height difference H

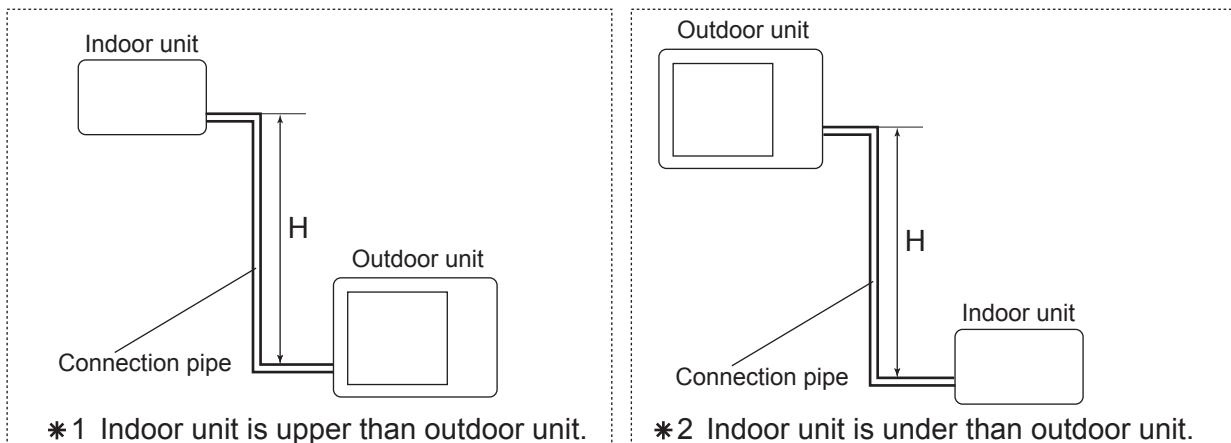

## 6. ADDITIONAL CHARGE CALCULATION

### ■ MODEL : AO \* R24LC

Refrigerant type		R410A
Refrigerant amount	g	1600

#### ● REFRIGERANT CHARGE

Pipe length	m	~15	20	25	30	20g/m
Additional charge	g	0 (Chargeless)	+100	+200	+300	

### ■ MODEL : AO \* R30LC

Refrigerant type		R410A
Refrigerant amount	g	2100

#### ● REFRIGERANT CHARGE

Pipe length	m	~20	30	40	50	40g/m
Additional charge	g	0 (Chargeless)	+400	+800	+1200	

## 7. AIR FLOW

### ■ MODEL : AO\*R24LC

#### ● COOLING

Number of rotations (r.p.m)	Air flow	
	1000	m <sup>3</sup> /h
l/s		650
CFM		1377

#### ● HEATING

Number of rotations (r.p.m)	Air flow	
	1050	m <sup>3</sup> /h
l/s		686
CFM		1454

### ■ MODEL : AO\*R30LC

#### ● COOLING

Number of rotations (r.p.m)	Air flow	
	850	m <sup>3</sup> /h
l/s		1000
CFM		2119

#### ● HEATING

Number of rotations (r.p.m)	Air flow	
	900	m <sup>3</sup> /h
l/s		1056
CFM		2236

# 8. OPERATION NOISE

## 8-1. NOISE LEVEL CURVE

### COOLING

MODEL : AO\*R24LC

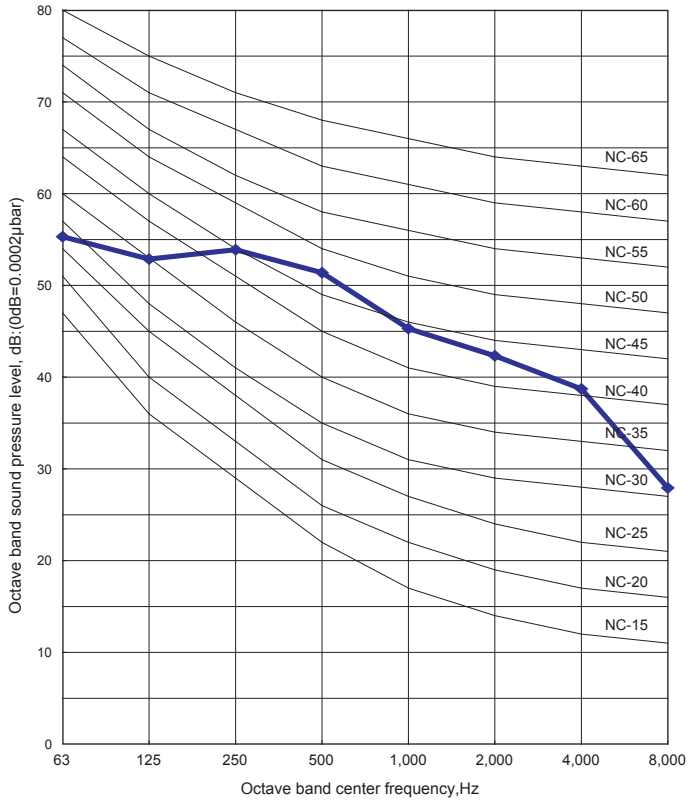

MODEL : AO\*R30LC

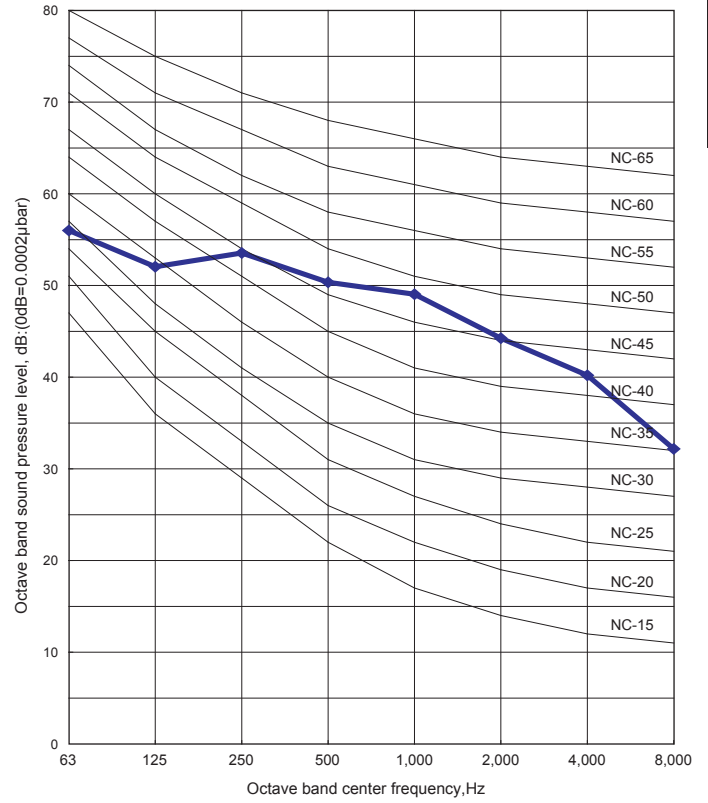

### HEATING

MODEL : AO\*R24LC

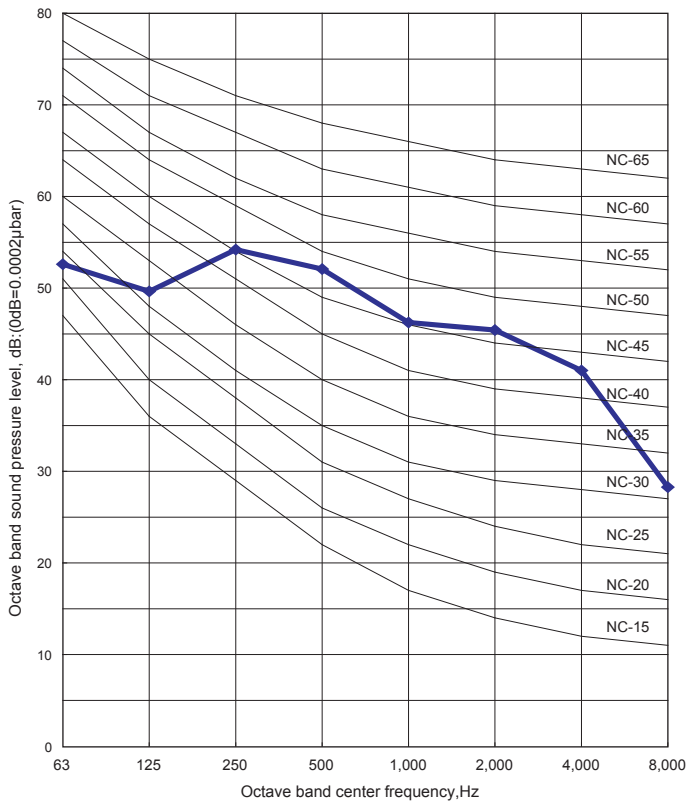

MODEL : AO\*R30LC

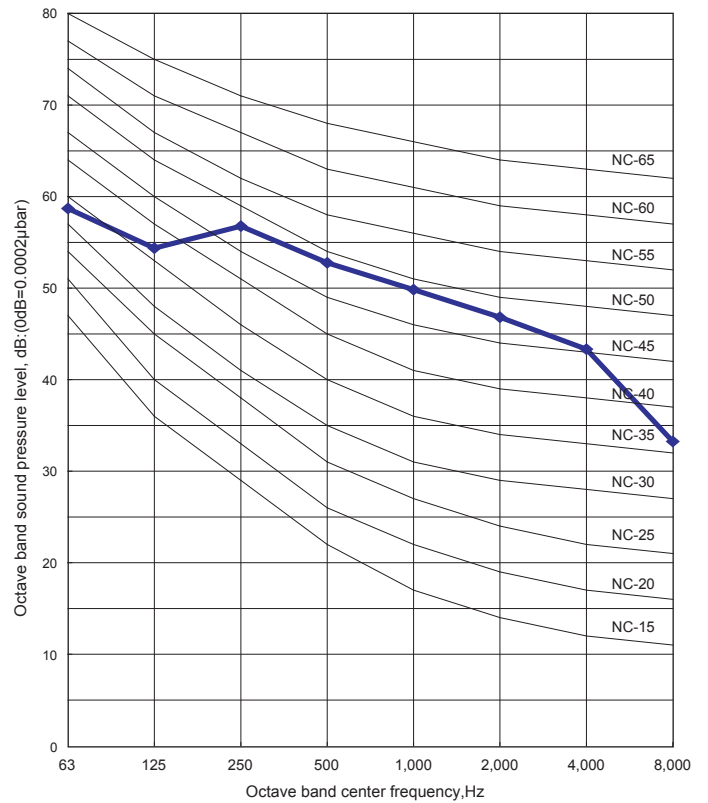



## 8-2. SOUND LEVEL CHECK POINT

OUTDOOR UNIT  
AO\*R24-30LC

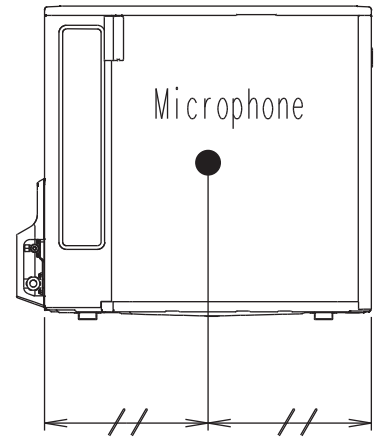
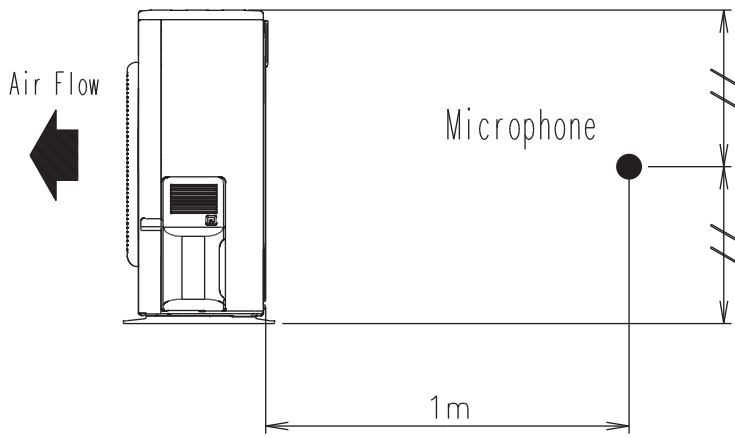

OUTDOOR UNIT  
AO\*R24-30LC

## 9. ELECTRIC CHARACTERISTICS

Model Name			AO * R24LC	AO * R30LC
Power Supply	Voltage	V	230~	
	Frequency	Hz	50	
Max Operating Current		A	17.5	18.5
Starting Current		A	9.8	11.7
*1) Wiring Spec.	Main Fuse (Circuit breaker) Current	A	30	30
	Power Cable	mm <sup>2</sup>	3.5 - 4.5	3.5 - 4.5
	*2)Limited wiring length	m	20	19

\*1) Wiring Spec.

Selected Sample

(Selected based on Japan Electrotechnical Standard and Codes Committee E0005)

\*2) Limited Wiring length :

This is the wiring length in case voltage descent is less than 2%.

When the wiring length becomes long, please select the wiring of a more larger diameter.

# 10. SAFETY DEVICES

	Protection form	Model	
		AO * R24LC	AO * R30LC
Circuit protection	Current fuse (NEAR THE TERMINAL)	20A 250V	20A 250V
		5A 250V	5A 250V
	Current fuse (MAIN PRINTED CIRCUIT BOARD)	15A 250V	15A 250V
		3.15A 250V	3.15A 250V
Fan motor protection	Thermal protection program	OFF : $110^{+15}_{-10}$ °C ON : $105^{+15}_{-10}$ °C	OFF : $130 \pm 20$ °C ON : $100 \pm 20$ °C
High Pressure Protection	Pressure Switch	-	OFF : $4.2 \pm 0.1$ MPa ON : $3.2 \pm 0.15$ MPa
Compressor protection	Thermal protection program (COMPRESSOR TEMP.)	-	OFF : 110 °C ON : After 40 minutes
	Thermal protection program (DISCHARGE TEMP.)	OFF : 110 °C ON : After 7 minutes	OFF : 110 °C ON : After 7 minutes

OUTDOOR UNIT  
AO\*R24-30LC

OUTDOOR UNIT  
AO\*R24-30LC