

SAVE VTC 200

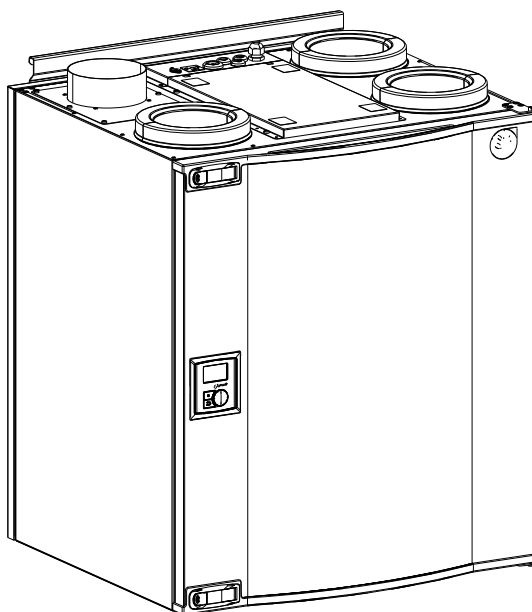

GB Installation and Service

Systemair is not liable or bound by warranty if these instructions are not adhered to during installation or service.

© 2013 Copyright Systemair AB

Systemair AB can accept no responsibility for possible errors in catalogues, brochures and other printed material. Systemair AB reserves the right to alter its products without notice. This also applies to products already on order provided that such alterations can be made without subsequent changes being necessary in specifications already agreed.

All rights reserved.

Contents

1 Declaration of Conformity	1
2 About this document	2
3 Warnings.....	2
4 Product information.....	2
4.1 General	2
4.2 Left and Right models.....	3
4.3 Transport and storage.....	3
4.4 Technical data.....	4
4.4.1 Dimensions and weight	4
4.4.2 Duct connections	6
4.4.3 Power consumption and fuse size.....	6
5 Installation.....	6
5.1 Unpacking.....	7
5.2 Where/how to install	7
5.3 Installation procedure	7
5.4 Condensation drainage.....	8
6 Commissioning.....	9
6.1 Control panel	9
6.1.1 Display symbols.....	10
6.2 Start up wizard	11
6.2.1 Procedure	11
6.2.2 Perform factory reset.....	13
6.3 System curves	13
6.3.1 Supply air, G4 type filter	14
6.3.2 Supply air, F7 type filter	15
6.3.3 Extract air, G4 type filter	16
6.4 Fan speed settings	16
6.4.1 Setting the fan speed	17
6.5 Defrost level settings	17
6.5.1 Setting the defrost level.....	18
6.6 Programming the week schedule.....	19
6.7 Ext/Force run	20
6.8 Extra functions	20
6.9 Electrical connection.....	21
6.9.1 Print card layout.....	21
6.9.2 External connection on the print card.....	22
6.10 External connections on the unit.....	23
7 Installation procedure of pre-heater relay card	23
8 Before starting the system	26
9 Operation	26
9.1 Setting the temperature	26
9.2 Manual setting of fan speed	26
9.3 Manual and automatic summer mode	27
9.4 Cool recovery.....	27
9.5 Service menu overview.....	28
10 Service.....	38
10.1 Warnings	38
10.2 Internal components	39
10.3 Components description	40
10.3.1 Fans.....	40
10.3.2 Filters.....	40
10.3.3 Heat exchanger	40
10.3.4 Print card.....	40
10.3.5 Temperature sensors.....	40
10.3.6 Electrical pre-heater battery	40
10.3.7 Electrical re-heater battery.....	41
10.3.8 Water re-heater battery.....	41
10.3.9 Water cooler	41
10.4 Trouble shooting.....	42
10.4.1 Alarm list	44

1 Declaration of Conformity

Manufacturer



Systemair AB
Industrivägen 3
SE-739 30 Skinnskatteberg SWEDEN
Office: +46 222 440 00 Fax: +46 222 440 99

hereby confirms that the following product:

Heat recovery ventilation unit: SAVE VTC 200

(The declaration applies only to product in the condition it was delivered in and installed in the facility in accordance with the included installation instructions. The insurance does not cover components that are added or actions carried out subsequently on the product).

Comply with all applicable requirements in the following directives:

- Machinery Directive 2006/42/EC
- Low Voltage Directive 2006/95/EC
- EMC Directive 2004/108/EC

The following harmonized standards are applied in applicable parts:

EN ISO 12100:2010	Safety of machinery - General principles for design - Risk assessment and risk reduction
EN 13857	Safety of machinery – Safety distances to prevent hazard zones being reached by upper or lower limbs
EN 60 335-1	Household and similar electrical appliances – Safety Part 1: General requirements
EN 60 335-2-40	Safety of household and similar electrical appliances – Part 2-40: Particular requirements for electrical heat pumps, air-conditioners and dehumidifiers
EN 60529	Degrees of protection provided by enclosures (IP Code)
EN 62233	Measurement methods for electromagnetic fields of household appliances and similar apparatus with regard to human exposure
EN 50 106	Safety of household and similar appliances – Particular rules for routine tests referring to appliances under the scope of EN 60 335-1 and EN 60967
EN 61000-6-2	Electromagnetic compatibility (EMC) – Part 6-2: Generic standards – Immunity for industrial environments
EN 61000-6-3	Electromagnetic compatibility (EMC) – Part 6-3: Generic standards – Emission standards for residential, commercial and light-industrial environments

The complete technical documentation is available.

Skinnskatteberg, 21-03-2014



Mats Sándor

Technical Director

2 About this document

This installation manual concerns air handling unit type SAVE VTC 200 manufactured by Systemair AB. The manual consists of basic information and recommendations concerning the design, installation, start-up and operation, to ensure a proper fail-free operation of the unit.

The key to proper and safe operating of the unit is to read this manual thoroughly, use the unit according to given guidelines and adhere to all safety requirements.

3 Warnings

The following admonitions will be presented in different sections of the document:

Danger

- Make sure that the mains supply to the unit is disconnected before performing any maintenance or electrical work!
- All electrical connections and maintenance work must be carried out by an authorized installer and in accordance with local rules and regulations.

Warning

- The system should operate continuously, and only be stopped for maintenance/service.
- The installation of the unit and complete ventilation system must be performed by an authorized installer and in accordance with local rules and regulations.
- Beware of sharp edges during mounting and maintenance. Use protective gloves.
- Although the Mains supply to the unit has been disconnected there is still risk for injury due to rotating parts that have not come to a complete standstill.
- Make sure that filters are mounted before starting the unit.
- This product must only be operated by a person which has suitable knowledge or education within this field or carried out with the supervision of a suitably qualified person.

Caution

- Do not connect tumble dryers to the ventilation system.
- Duct connections/duct ends must be covered during storage and installation.

4 Product information

4.1 General

The SAVE VTC 200 is a heat recovery ventilation unit, with a built in counter flow heat exchanger. The SAVE VTC 200 is suitable for houses with up to 160 m² heated living area.

The interior of the unit is made out of EPP (Expanded polypropylene) and the external cover out of painted sheet metal parts.

The SAVE VTC 200 supplies filtered outdoor air to residential areas and extract air from bathroom, kitchen and wet rooms.

Pre- and re-heater are available as accessories (chapter 10.3.6, chapter 10.3.7) and can be mounted externally to the duct system. The heaters are regulated from the unit control or by an external control.

4.2 Left and Right models

There are two model options, right (R) and left (L) model. The different models are recognized by the placing of the internal components and the supply air outlet, which is situated on left side of the unit on an (L) unit and on the right hand side on an (R) unit.

Note:

This document describes a left (L) model.

4.3 Transport and storage

The SAVE VTC 200 should be stored and transported in such a way that it is protected against physical damage that can harm panels etc. It should be covered so dust, rain and snow cannot enter and damage the unit and its components.

The appliance is delivered in one piece containing all necessary components, wrapped in plastic on a pallet for easy transportation.

4.4 Technical data

4.4.1 Dimensions and weight

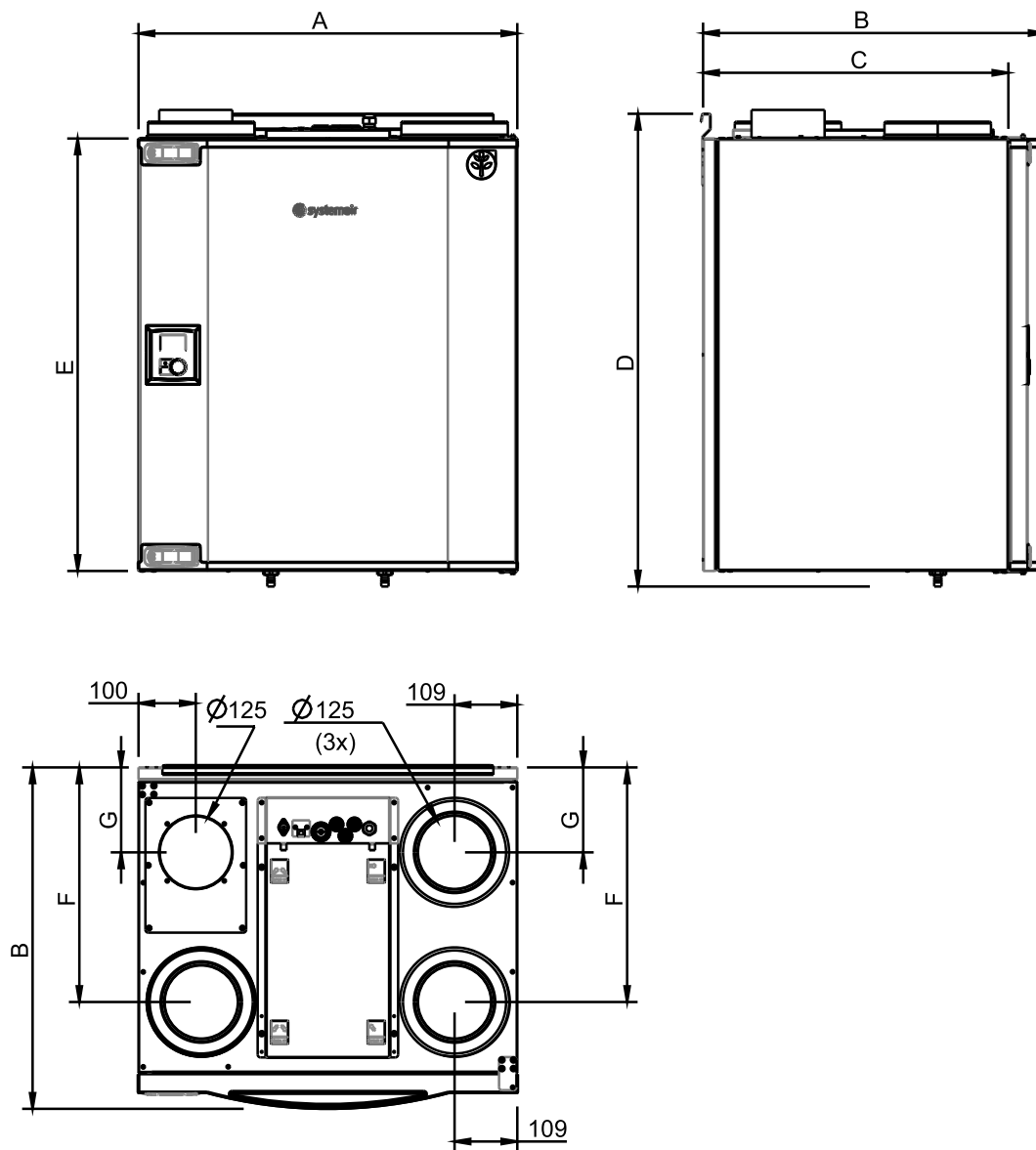

Fig. 1 Dimension (mm) and weight (kg), L model

	A	B	C	D	E	F	G	Weight
SAVE VTC 200	660	597	534	822	752	408	148	42

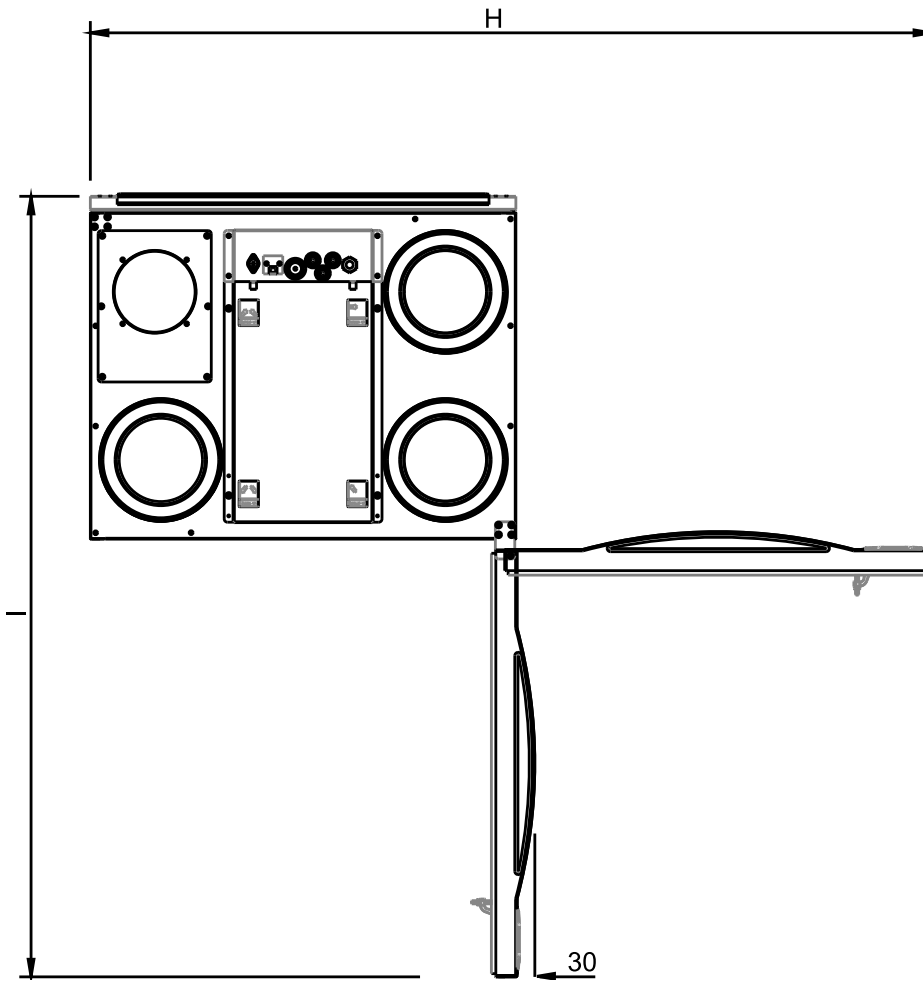
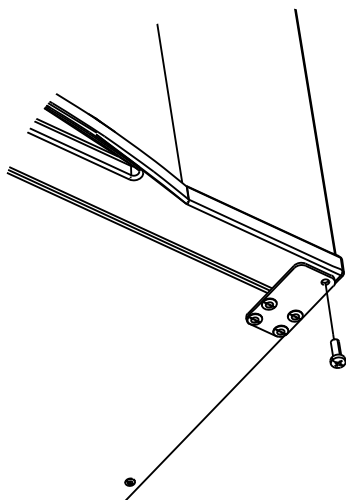

Fig. 2 Open hatch dimensions (mm)

	H	I
SAVE VTC 200	1302	1207

The hatch can be lifted off by loosening a screw at the bottom of the unit.



4.4.2 Duct connections

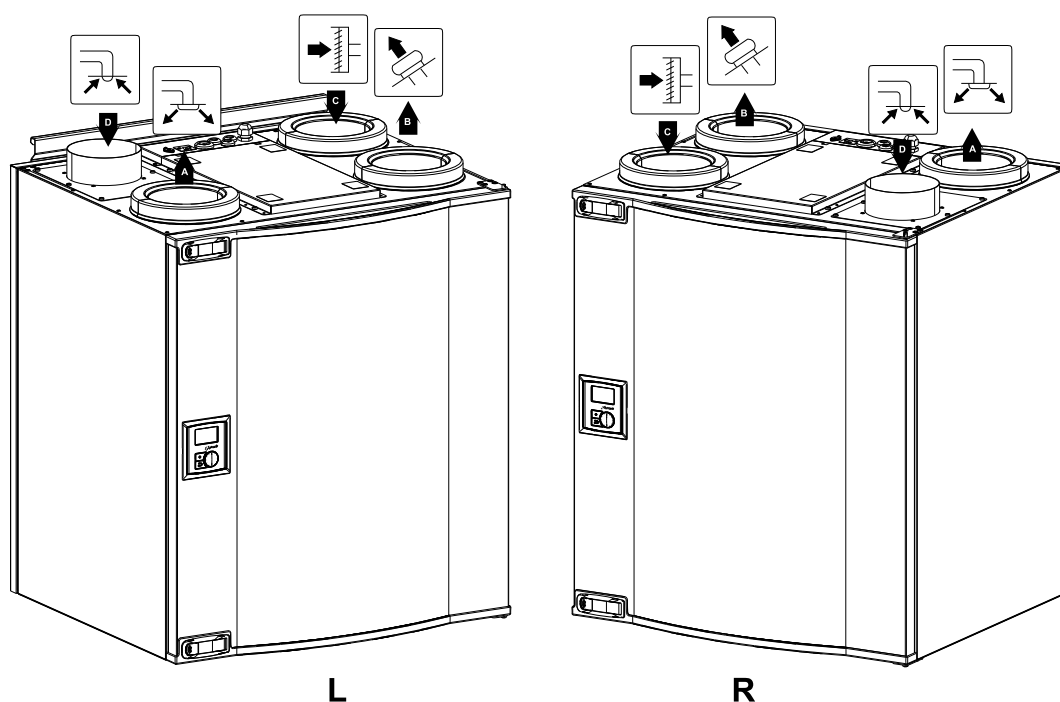

Fig. 3 Duct connections

Position	Description
R	Right hand model (Supply air connection is situated on the right hand side of the unit viewed from the front)
L	Left hand model (Supply air connection panel is situated on the left hand side of the unit viewed from the front)

Symbol	Description	Symbol	Description
	A Supply air		C Outdoor air
	B Exhaust air		D Extract air

4.4.3 Power consumption and fuse size

Fans	112 W
Total power consumption	112 W
Fuse	10 A

5 Installation

This section describes how to install the unit correctly. To ensure a proper and fail-free operation, it is important that the unit is installed according to these instructions.

5.1 Unpacking

Verify that all ordered equipment are delivered before starting the installation. Any discrepancies from the ordered equipment must be reported to the supplier of Systemair products.

5.2 Where/how to install

The SAVE VTC 200 should preferably be installed in a secondary room (e.g. storeroom, laundry room or similar).

When choosing the installation position, consideration must be taken that the unit requires regular maintenance. Leave free space for opening of the front hatch in order to perform service and maintenance on components inside the unit.

The SAVE VTC 200 is supplied with approximately 1 m cable and plug for 230V, single phase earthed connection placed on the top of the unit.

Recommended installation location for the outdoor air intake is the northern or eastern side of the building and with a distance to openings for discharge of stale ventilation air, kitchen ventilator, central vacuum system, waste water drainage and other pollution sources like exhaust from traffic etc. Stale discharge air should ideally be led via a roof unit to the outside and with a good distance to any outdoor air intake, windows etc.

5.3 Installation procedure

1

Prepare the surface where the unit is to be mounted. Make sure that the surface is flat, levelled and that it supports the weight of the unit. Perform the installation in accordance with local rules and regulations.

2

Fit the mounting bracket (pos. 1) with the anti vibration pad (pos. 2) to the wall with enclosed screws. Use appropriate holes to screw the bracket firmly to the wall. Bottom side of bracket should be 40 mm (H) below top of unit position.

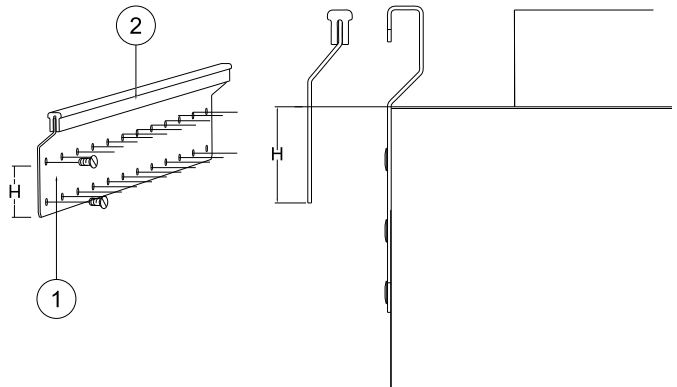

3

Add the anti vibration list (pos 1) on the lower half of the units backside, delivered with the unit. Lift the unit in place.

Warning

Beware of sharp edges during mounting and maintenance. Use protective gloves

Note:

Assure that the unit is completely vertical once mounted on the wall. The unit must not be tipping forward in order for the condensation drainage to function.

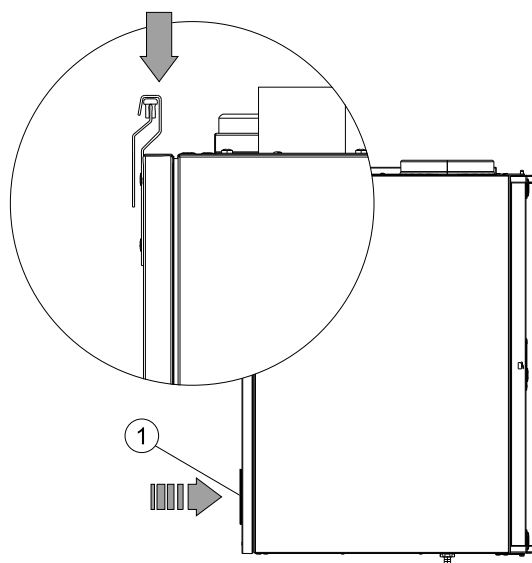

4

Connect the unit to the duct system. Make sure that all necessary accessories are used to create a functional ventilation solution.

Warning

The installation of the unit and complete ventilation system must be performed by an authorized installer and in accordance with local rules and regulations.

5.4 Condensation drainage

Depending on the relative humidity in the extract air, condensation may occur on the cold surfaces of the unit. The condensate water is led out through the drainage (exhaust air side) situated on the bottom of the unit. A one meter hose with 13 mm ($\frac{1}{2}$ ") connection and a hose clamp are included at delivery. Exhaust air side drainage is not mounted with an end cap at delivery.

The drainage on the supply air side are mounted with an end cap at delivery. In summer periods, when the outdoor air has a high humidity and the indoor air is cool, condensation can occur on the supply air side. Remove the end cap and connect a hose (available as an accessory).

The height (H) must be at least 60 mm.

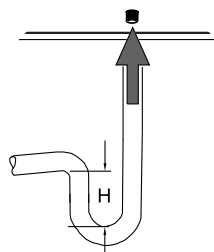

6 Commissioning

6.1 Control panel

Connect the unit electrically to the mains with the enclosed plug and check that it starts up correctly.

The control panel is used to make the necessary adjustments.

An external control panel can be connected on the top of the unit.

The illustration below shows the control panel with a short description.

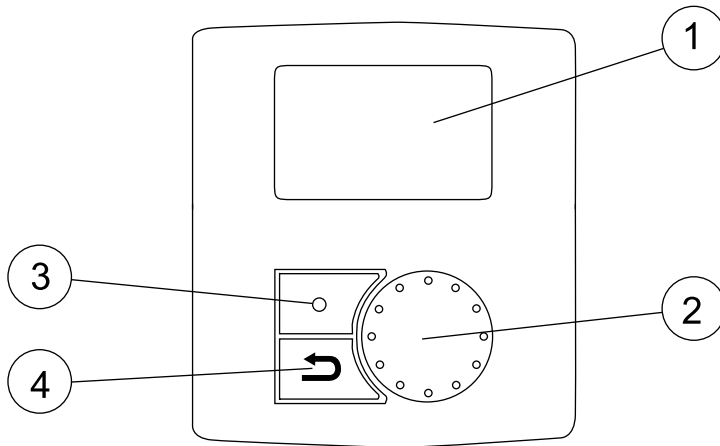
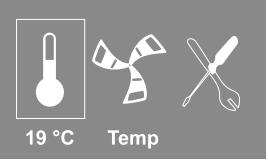









Fig. 4 Control panel

Position	Description	Explanation
1	Display	Shows symbols, menus and settings
2	SELECTION knob	Move through the menu lists or change settings and values by turning the knob left or right
3	ENTER button	ENTER menu choices or settings by pressing the button
4	RETURN button	Step RETURN in the menu levels and to abort an initiated parameter change and restore the original value by pressing the button

6.1.1 Display symbols

Symbol	Description	Explanation
	Temp	<p>Illustrates the current set-point for supply air temperature (from completely empty to filled symbol).</p> <p>Turn the SELECTION knob to choose temperature.</p> <p>Press ENTER to save the setting.</p>
	Fan speed	<p>Illustrates the current fan speed. The fan speed can be set manually in 4 steps: Off, Low, Nom and High.</p> <p>Turn the SELECTION knob to choose fan speed.</p> <p>Press ENTER to save the setting.</p> <div style="display: flex; justify-content: space-around; align-items: center;">      </div> <p style="text-align: center;">A B C D E</p> <p>A. Ventilation off.¹</p> <p>B. Low ventilation: Can be used when leaving the building for a longer period</p> <p>C. Nominal ventilation: Will give required air change under normal conditions.</p> <p>D. Maximum ventilation: To increase the airflow if necessary.</p> <p>E. When demand control is activated, fans should go to "auto mode" and regulate after the pre-setting for the demand control settings.</p>
	Service	Press ENTER to access the service menu.
	Alarm	Press ENTER to access the alarm list.

1. The fan can be set to OFF by activating manual fan stop. See service menu description under functions.

Warning

It is not recommended to activate manual fan stop (set fan to OFF) in standard households. If manual fan stop is activated, the unit should be provided with dampers in exhaust and fresh air ducts to avoid cold draught and risk of condensation when the unit has been stopped.

6.2 Start up wizard

The **Start up Wizard** is a step-by-step configuration tool that starts automatically when the SAVE VTC 200 is started for the first time or when:

- a factory reset is performed
- a new print card is installed (spare part)
In this case the unit type must be entered (SAVE VTC 200)

The fan speed in the Start up wizard can be set by either l/s, m³/h or a percentage with the Fan control.

- If **Airflow** is chosen, the settings will be in l/s or m³/h and system curves are selected.
- If **Speed** is chosen, the settings will be in percentage. System curves are not selectable.

6.2.1 Procedure

1. Turn the SELECTION knob to choose language and press ENTER	Languages Language ENGLISH
2. Choose unit type, this choice is only present if a new print card is installed (spare part) or when a factory reset is performed.	Type SAVE VTC 200
3. Set date and time	Time/Date YY/MM/DD Date: 12/09/12 Time: 10:00
4. Select heater: None/Electrical/Water	Heater Pre-heater: YES/NO Re-heater: None/Electrical/Water
Note: This choice is available only after a factory reset, see chapter 6.2.2, or when a new print card is installed.	

<p>5. Fan control.</p> <p>Turn the SELECTION knob to select the type of fan control you prefer, Airflow (l/s or m³/h) or Speed (%) and press ENTER.</p> <p>Commission by %, see step 7.</p> <hr/> <p>Note:</p> <p>System curves are not selectable when Speed is chosen.</p> <hr/> <p>Note:</p> <p>Before setting the system curve, see chapter 6.3 for details.</p> <hr/> <p>This function is implemented in the unit to compensate the flow values for different system pressures.</p> <p>Supply Fan (SF): Total value range: 1–20. For G4 type filter: 1–10, for F7 type filter: 11–20. Default curve: 2</p> <p>Extract Fan (EF): Value range: 1–10 Default curve: 2</p> <hr/> <p>Note:</p> <p>The factory installed filters are of filter quality G4 for the supply air and G4 for the extract air filter. Air filters are accessories and can be obtained from the installer or wholesaler.</p> <p>The filter type is labelled on the top of the filter.</p> <hr/>	<p>Fan control, Airflow</p> <p>System curve</p> <p>EF: 1–10 SF: 1–20</p>												
<p>6. Here it is possible to change the Nominal/High/Low airflow on the Extract and Supply air fans. Airflow in l/s or m³/h.</p> <p>When settings are done, press ENTER.</p>	<table border="1"> <thead> <tr> <th>Airflow l/s</th> <th>EF</th> <th>SF</th> </tr> </thead> <tbody> <tr> <td>Nom</td> <td>50</td> <td>50</td> </tr> <tr> <td>High</td> <td>72</td> <td>72</td> </tr> <tr> <td>Low</td> <td>30</td> <td>30</td> </tr> </tbody> </table>	Airflow l/s	EF	SF	Nom	50	50	High	72	72	Low	30	30
Airflow l/s	EF	SF											
Nom	50	50											
High	72	72											
Low	30	30											
<p>7. Here it is possible to change the Nominal/High/Low fan speed on the Extract and Supply air fans. Fan speed in %. System curves not selectable.</p> <p>When settings are done, press ENTER.</p>	<table border="1"> <thead> <tr> <th>Speed %</th> <th>EF</th> <th>SF</th> </tr> </thead> <tbody> <tr> <td>Nom</td> <td>50</td> <td>50</td> </tr> <tr> <td>High</td> <td>100</td> <td>100</td> </tr> <tr> <td>Low</td> <td>25</td> <td>25</td> </tr> </tbody> </table>	Speed %	EF	SF	Nom	50	50	High	100	100	Low	25	25
Speed %	EF	SF											
Nom	50	50											
High	100	100											
Low	25	25											

6.2.2 Perform factory reset

How to perform a factory reset if necessary:

<p>1. Enter the service menu by selecting the service symbol in the display and press ENTER.</p>	
<p>2. Go to password and enter the password, default 1111 Use the SELECTION knob for each digit and ENTER with the ENTER button after each set digit and choose NO for the system not be locked.</p>	<p>Password Password XXXX Locked YES/NO</p>
<p>3. Go to Functions and select Factory Reset</p>	<p>Functions Factory reset</p>
<p>4. Turn the SELECTION knob so YES is shown and press ENTER.</p>	<p>Factory reset Really reset? YES/NO</p>
<p>5. ACCEPTED is shown in the display window</p>	<p>ACCEPTED</p>
<p>6. The Start up Wizard starts after approximately 10 seconds</p>	

6.3 System curves

A system requires different pressures at different airflows, which can be represented by a system curve. The intersection between the system line and the fan curve, is the unit's working point. It is showing the airflow the system is going to have. Every change in the pressure of the ventilation system, will give rise to a new system curve.

If you choose to do the commissioning with l/s or m³/h, you ought to know what kind of pressure you have in the system in order to choose a suitable system curve.

6.3.1 Supply air, G4 type filter

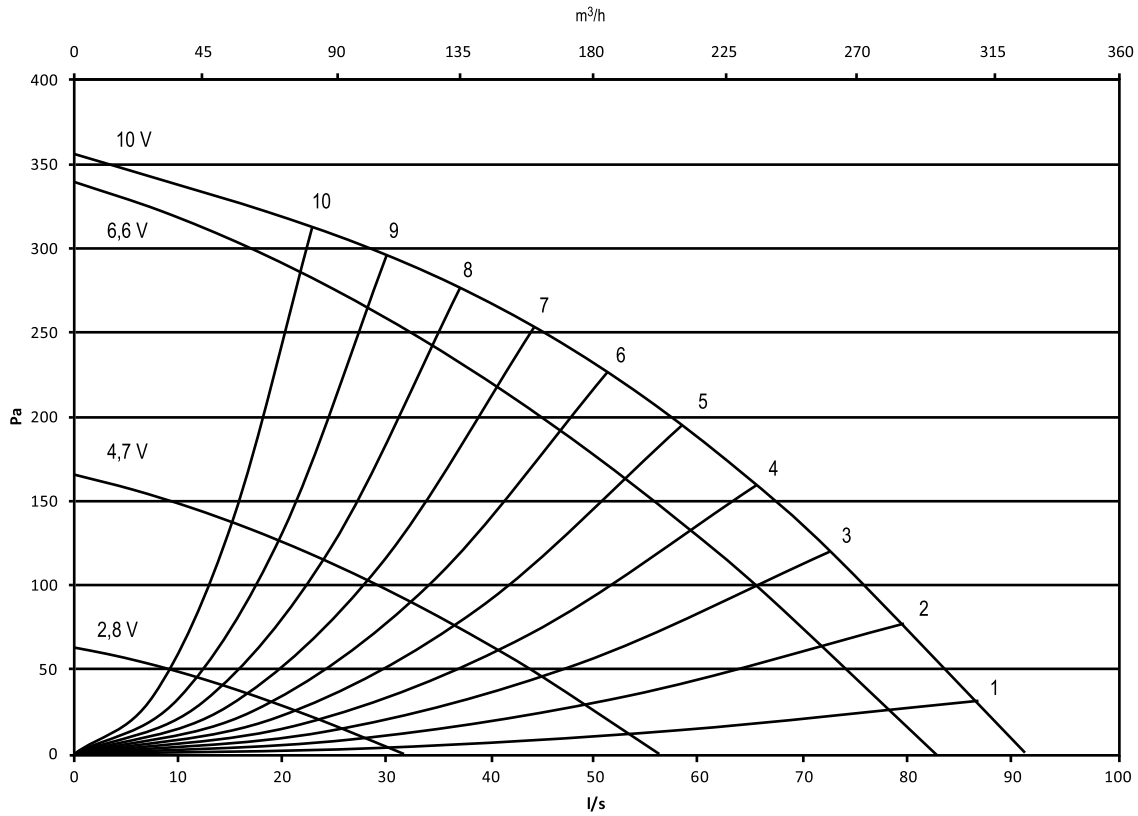

Fig. 5 Supply air system curves, G4 type filter

6.3.2 Supply air, F7 type filter

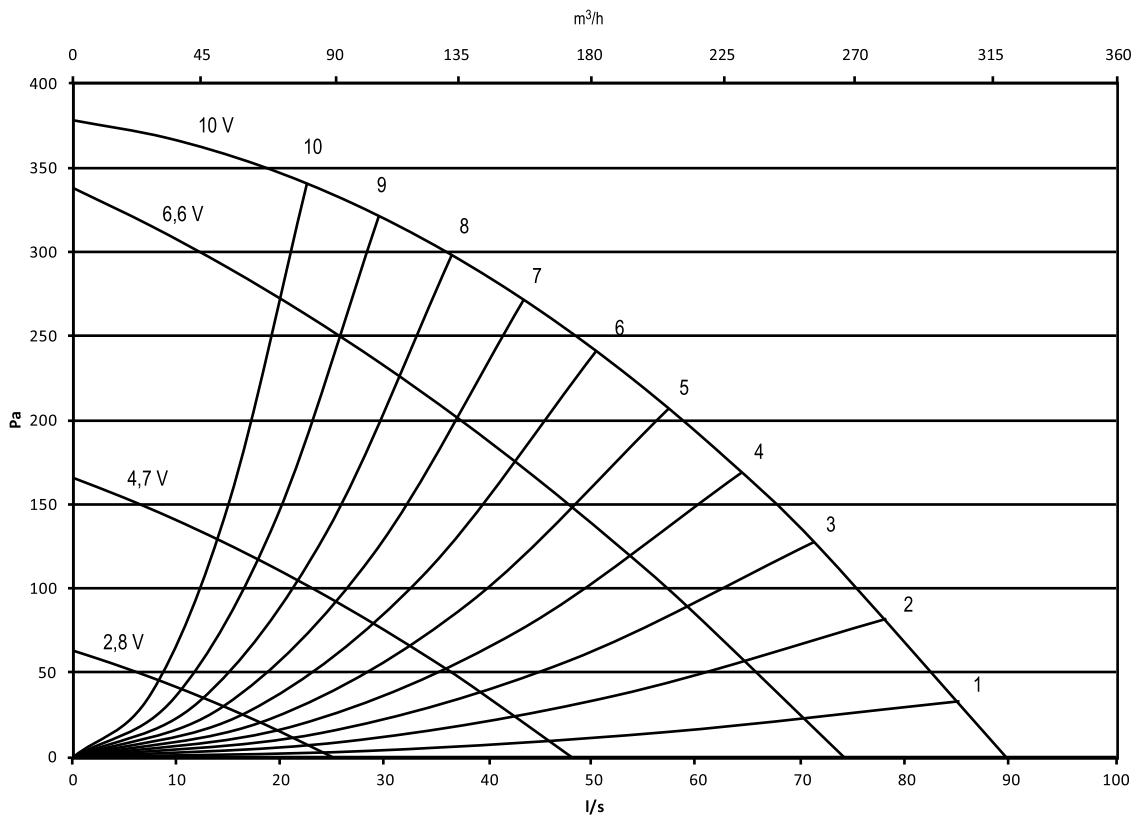

Fig. 6 Supply air system curves, F7 type filter

6.3.3 Extract air, G4 type filter

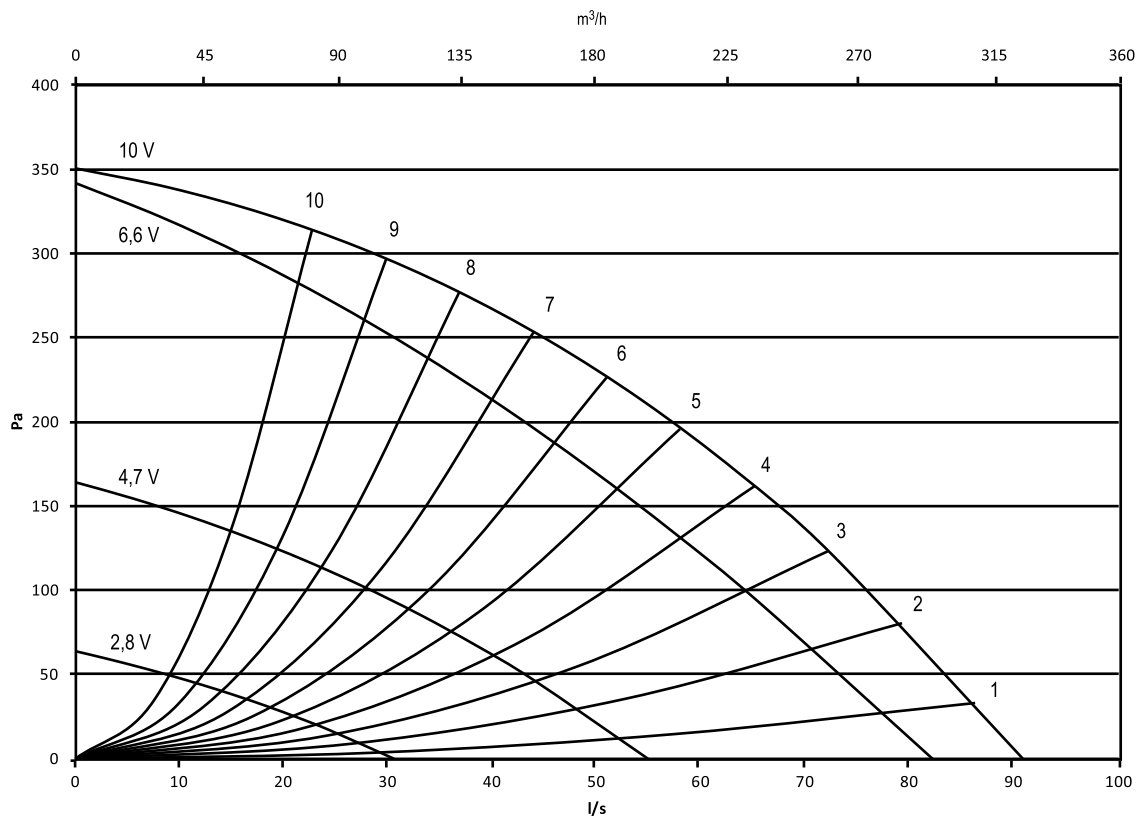

Fig. 7 Extract air system curves, G4 type filter

6.4 Fan speed settings

The fan speed can be set by either l/s, m³/h or a percentage.

- If **Airflow** is chosen in the service menu, the settings will be in l/s or m³/h and system curves are selected.
- If **Speed** is chosen in the service menu, the settings will be in percentage. System curves are not selectable.

The fan speed may be adjusted in five steps; off, low, nominal, high and auto. These settings control the output signals to the supply- and extract fans. The factory setting on each speed steps are:

- Off
- Low: 30 l/s or 25 %.
- Nom: 50 l/s or 50 % (at approximately 80 Pa).
- High: 72 l/s or 100 %.

These levels are possible to change in the service level. See service menu overview (chapter 9.5) under functions.

Warning

It is **not** recommended to activate manual fan stop (set fan to OFF) in standard households. If manual fan stop is activated, the unit should be provided with dampers in exhaust and fresh air ducts to avoid cold draught and risk of condensation when the unit has been stopped.

The fan can be set to OFF by activating manual fan stop. See service menu overview (chapter 9.5) under functions.

6.4.1 Setting the fan speed

<p>1. Go to the service menu by using the SELECTION knob</p>	 <p>Service</p>												
<p>2. Enter the service level by typing the password, default 1111. Use the SELECTION knob for each digit and confirm with the ENTER button after each set digit and choose "NO" for the system not be locked.</p>	<p>Password Password XXXX Locked YES/NO</p>												
<p>3. Go to: Functions Choose: Fan control</p>	<p>Functions -> Fan control</p>												
<p>4. Turn the SELECTION knob to select the type of fan control you prefer, Airflow (l/s or m³/h) or Speed (%) and press ENTER. Fan control by speed, see step 7.</p>	<p>Fan control Airflow Speed</p>												
<p>5. Fan control by Airflow l/s. When settings are done, press ENTER. Choose system curve.</p>	<p>Fan control Airflow system curve SF:4 EF:4</p>												
<p>6. Press BACK once the system curves has been set and go to Airflow l/s or m³/h. When settings are done, press ENTER.</p>	<table border="1"> <thead> <tr> <th>Airflow l/s</th> <th>EF</th> <th>SF</th> </tr> </thead> <tbody> <tr> <td>Nom</td> <td>50</td> <td>50</td> </tr> <tr> <td>High</td> <td>72</td> <td>72</td> </tr> <tr> <td>Low</td> <td>30</td> <td>30</td> </tr> </tbody> </table>	Airflow l/s	EF	SF	Nom	50	50	High	72	72	Low	30	30
Airflow l/s	EF	SF											
Nom	50	50											
High	72	72											
Low	30	30											
<p>7. Fan control by Speed % When settings are done, press ENTER.</p>	<table border="1"> <thead> <tr> <th>Speed %</th> <th>EF</th> <th>SF</th> </tr> </thead> <tbody> <tr> <td>Nom</td> <td>50</td> <td>50</td> </tr> <tr> <td>High</td> <td>100</td> <td>100</td> </tr> <tr> <td>Low</td> <td>25</td> <td>25</td> </tr> </tbody> </table>	Speed %	EF	SF	Nom	50	50	High	100	100	Low	25	25
Speed %	EF	SF											
Nom	50	50											
High	100	100											
Low	25	25											

6.5 Defrost level settings

The units are designed for a min outdoor temp of -15° C. At low outdoor temperatures a pre-heater is required to avoid that the exchanger freezes.

The unit is equipped with an automatic defrost function that is activated when there is risk of icing in the area around the heat exchanger. The setting 1-5 (table 1) determines how aggressive the defrosting will be. Default factory setting is mode 3.

Note:

The heat exchanger should withstand low outdoor temperatures, but in those cases where icing can occur please be aware of that the defrost setting will generate an under pressure in the building. Using a fire place, be aware that there is a possible risk of smoke being extracted into the living areas due to under pressure if defrosting is activated.

Table 1: Defrost levels

Defrost mode	Level of humidity	Relative humidity indoors ¹	Description
1	Min	<20%	Dry areas, such as warehouse buildings with few people or industrial buildings that don't use water in their production process.
2	Low	Low 30% - 40%	Office buildings
3	Medium	41% - 60%	Apartments or houses with normal humidity ²
4	High	High 61% - 80%	Apartments or houses with high humidity
5	Extremely high	>80%	Buildings with very high humidity level.

1. *Relative humidity in the extract air at low outdoor temperatures.*
2. *In newly constructed houses it might be necessary with a higher defrost level during the first winter period.*

6.5.1 Setting the defrost level

1. Go to the service menu by using the SELECTION knob.	
2. Enter the service level by typing the password, default 1111. Use the SELECTION knob for each digit and confirm with the ENTER button after each set digit and choose "NO" for the system not be locked.	Password Password XXXX Locked YES/NO
3. Go to: Functions Choose: Defrosting	Functions Defrosting
4. Set the mode, 1 – 5	Defrosting Mode 1-5
5. Select if unbalanced airflows are allowed in the building during the defrost cycle. Choose between YES and NO. Default is YES.	Allow unbalance YES/NO

6.6 Programming the week schedule

Set the week schedule according to below procedure:

<p>1. Go to the service menu by using the SELECTION knob.</p>	
<p>2. Enter the service level by typing the password, default 1111. Use the SELECTION knob for each digit and confirm with the ENTER button after each set digit and choose "NO" for the system not be locked.</p>	<p>Password Password XXXX Locked YES/NO</p>
<p>3. Go to: Week program</p>	<p>Service Week program</p>
<p>4. Choose Week program again.</p>	<p>Week program Fan speed</p>
<p>5. Set week day and time you want the unit to be in ON level. Two periods per day can be programmed. The rest of the time the unit will be in OFF level.</p>	<p>Week program Day: MON Per 1: 07:00 16:00 Per 2: 00:00 00:00</p>
<p>6. Go back to the previous dialogue frame with the RETURN button and go down to Fan speed.</p>	<p>Week program Fan speed</p>
<p>7. Set which fan speed the fan is supposed to be running in the ON level, choose between Low, Nom, High or Auto.</p> <p>Set which fan speed the fan is supposed to be running in the OFF level, choose between OFF, Low, Nom or High.</p> <hr/> <p>Note:</p> <p>If an electrical re-heater battery is installed and active and the unit is shut down from the control panel, for example by choosing OFF. When the unit is in OFF level in the week program, the fans will continue to run for 3 minutes, to prevent the heater from triggering the over heat protection sensor, before they stop.</p> <hr/>	<p>Fan speed On level: low/nom/high/auto Off level: off/low/nom/high</p>
<p>8. Step back with the RETURN button until you reach the main menu display</p>	

6.7 Ext/Force run

It is possible to program extended time you want the unit to work under operation conditions other than determined by the week schedule.

<p>1. Go to the service menu by using the SELECTION knob.</p>	
<p>2. Enter the service level by typing the password, default 1111. Use the SELECTION knob for each digit and confirm with the ENTER button after each set digit and choose "NO" for the system not be locked.</p>	<p>Password Password XXXX Locked YES/NO</p>
<p>3. Go to: Ext/Force Run</p>	<p>Service Ext/Force Run</p>
<p>4. Set the time in minutes the unit is to run in extended/forced running mode. Value range: 0–240 minutes, in steps of 10 min.</p> <p>Set the fan speed for this mode. Choose between Low, Nom or High. Default value: Nom.</p>	<p>Ext/Force Run</p> <p>Minutes: 0</p> <p>Fan speed: Nominal</p>

6.8 Extra functions

The unit is equipped with a number of extra on/off functions which can be activated from external on/off switches that can be connected to the digital inputs on the main print card (see wiring diagram).

The following possibilities are available:

- **Digital inputs 1–3:** By connecting on/off switches to these inputs it's possible to choose 3 individual fan speed settings in the control panel depending on a temporary need for the building (for example lowering the extract air fan speed when an open fire place is used). See chapter 9.5.
 DI 3, is prepared and already connected internally for easy access on the unit. See chapter 6.10.
- **Digital input 4:** Makes it possible to disable the electrical re-heater
 Activated input means that the electrical re-heater is disabled.
- **Digital input 5:** Activate the Extended/forced running function with a impulse switch. The function overrides current fan speed settings and runs in forced mode according to the settings in *Service* -> *Ext/Force run*. Choose between Low, Nom and High for this function.
 The input is calculated based on the signals from an impulse-switch. If a standard switch is used, the countdown of the set time starts when the switch is switched off.
- **Digital input 6:** Control for the damper, limit switch integrated in the system
- **Digital input 7:** Home/leave, switching on this activates low energy support control. The heat exchanger is always operating according to the setpoint value. Is there a re-heater activated it will operate according to the lowest setpoint value (12 °C). The function is used when the building is uninhabited for a longer period.
 It is recommended to connect either of DI1, DI2 or DI3 in parallel with DI7. If DI7 is activated, set the fans speed to min. Fan speed settings are done when configuring DI1, DI2 or DI3.

See menu options in "Service menu Overview" (chapter 9.5).

6.9 Electrical connection

The SAVE VTC 200 is wired internally from factory.
The electrical connection box is on top of the unit behind a cover plate.

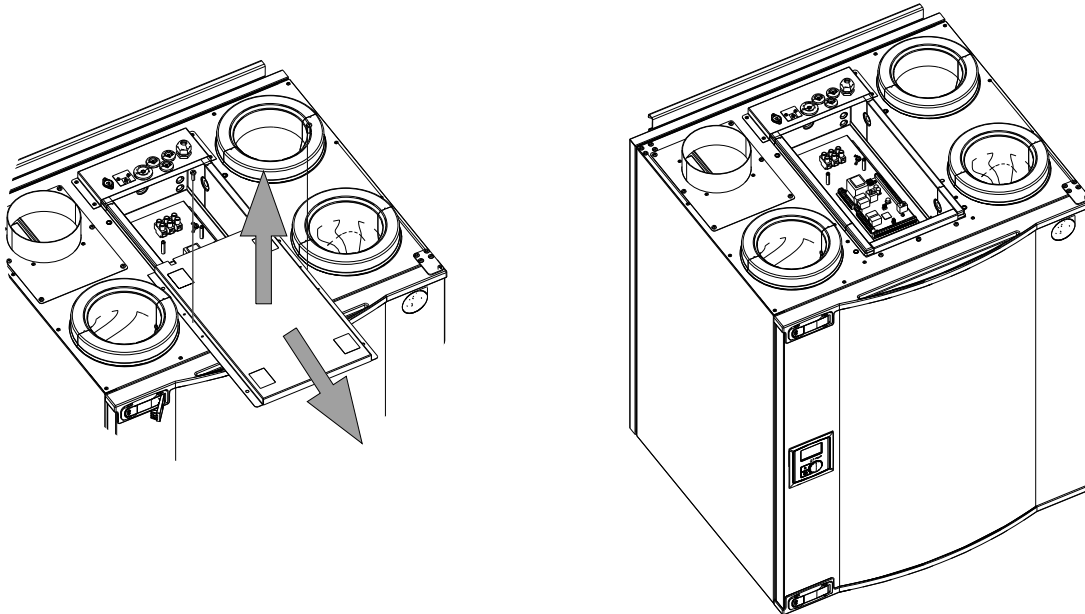

6.9.1 Print card layout

The SAVE VTC 200 is equipped with built-in regulation and internal wiring.
The figure shows the print card. See wiring diagram for more information.

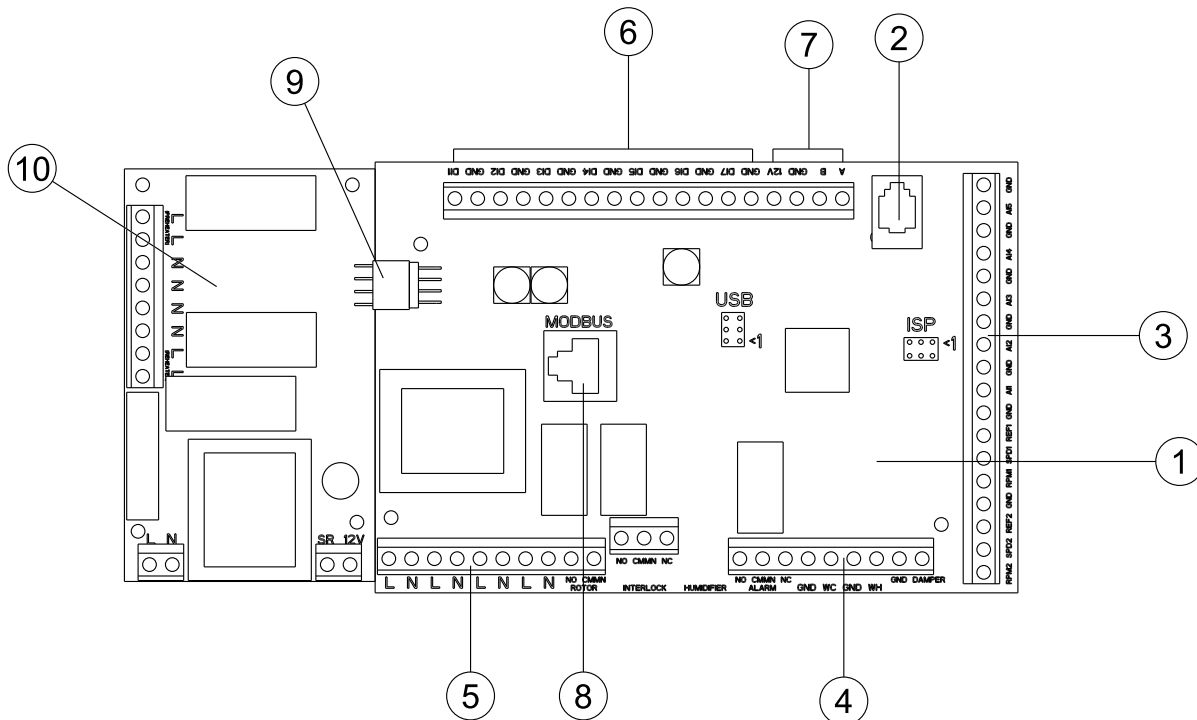

Fig. 8 Print card

Position	Description
1	Main print card
2	Connection to external control panel (connected to unit casing)
3	Terminals for AI 1–5 (temp sensors) and motor control
4	Terminals for external connections
5	Terminals for mains supply connections
6	Terminals for digital inputs (DI 1–7)
7	Terminals for internal control panel.
8	Modbus connection. See "User manual Modbus" for details.
9	Connection electrical pre-heater relay print card

6.9.2 External connection on the print card

Connection terminals for external equipment can be found on the main print card inside the electrical connection box.

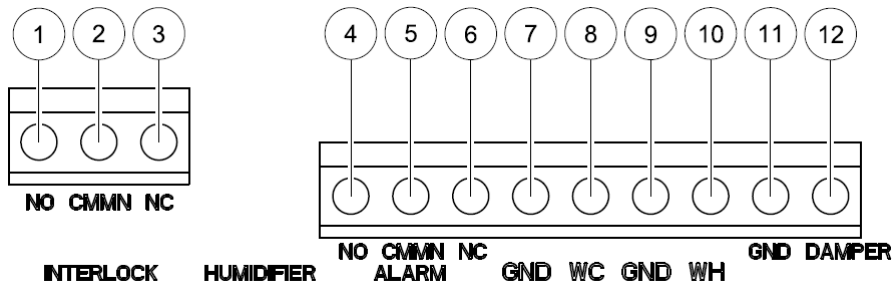

Fig. 9 External connections on the print card

Position	Description	Remark
1	Outdoor/exhaust air damper	Normally open, 230 V 1~, max 1 A
2	Outdoor/exhaust air damper	Reference
3	Outdoor/exhaust air damper	Normally closed, 230 V 1~, max 1 A
4	Sum alarm	Normally open, 24 V, max 1 A
5	Sum alarm	Reference
6	Sum alarm	Normally closed, 24 V, max 1 A
7	GND	Reference
8	Water cooler control signal (AO2)	0–10 V DC
9	GND	Reference
10	Water heater control signal (AO1)	0–10 V DC
11	GND	Reference
12	Bypass damper (AO3)	0–10 V DC

6.10 External connections on the unit

Two of the connections on the main print card are wired to plugs on the unit casing:

- connection to an external control panel through a modular connector.
Maximum cable length: 50 m.
Cable type: Flat 4-conductor CEC Phone cable, or equivalent.
- connection to DI 3 with possibility to configure the fan speeds individually through a potential free on/off switch

Default settings: SF=High, EF=Low.

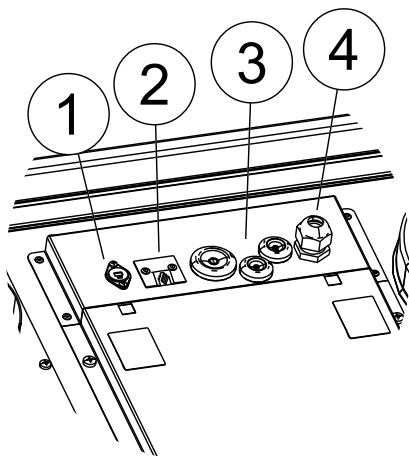

1. Connection to DI 3 through a potential free on/off switch
2. Connection to control panel
3. Cable glands
4. Mains cable

7 Installation procedure of pre-heater relay card

An electrical pre-heater can be ordered as an accessory and be installed externally. Pre-heater function is regulated by the integrated outdoor temperature sensor (OS) and related to selected defrosting level. Below instructions describes the procedure for the installation of the pre-heater relay card. A kit with relay-card, power supply cables and 4 screws can be ordered.

Danger

- Make sure that the mains supply to the unit is disconnected before performing any maintenance or electrical work!
- All electrical connections and maintenance work must be carried out by an authorized installer and in accordance with local rules and regulations.

1

Disconnect the unit from the mains supply.

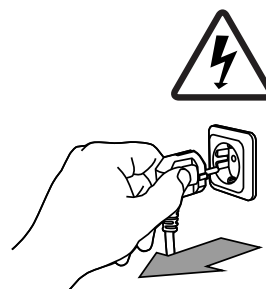

2

Connect the heater card to the main print card using the prepared connection on the side of each print card. Fastening the pre-heater relay card on the prepared distances next to the main print card with the enclosed screws.

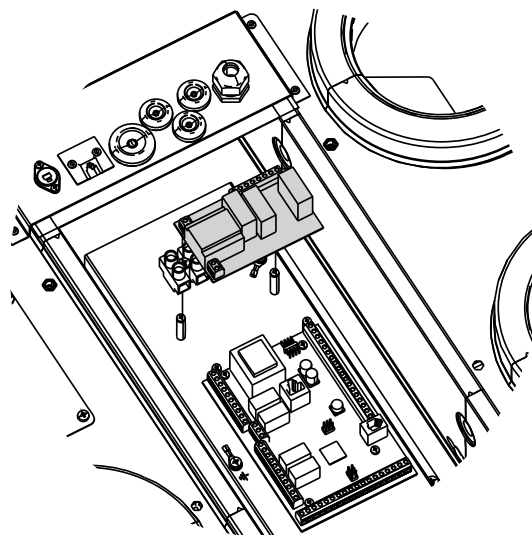

3

Connect the power supply blue and the brown cables (pos 1) to the free L/N terminals on the main print card. See wiring diagram for detailed information.

Note:

Cables for power supply and bridging of ET are included in the heater card kit

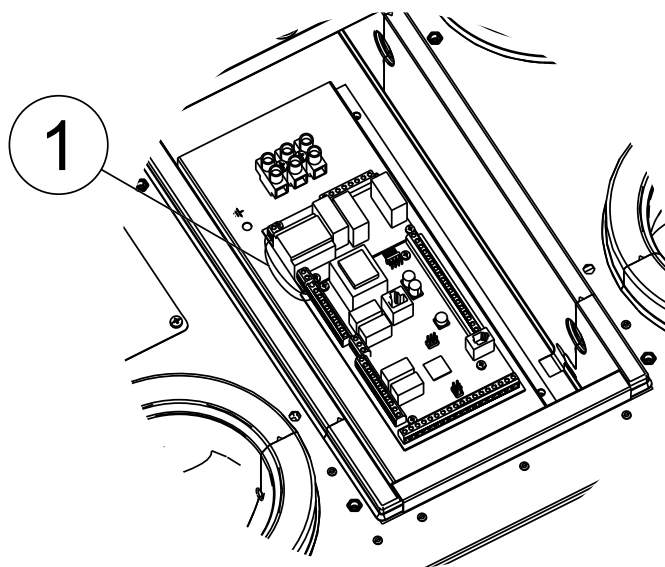

4

Connect the duct heater power supply and ET to the relay card. See chapter 6.9.1 and wiring diagram for detailed information.

Note:

If the heater has built in overheat protection ET has to be bridged.

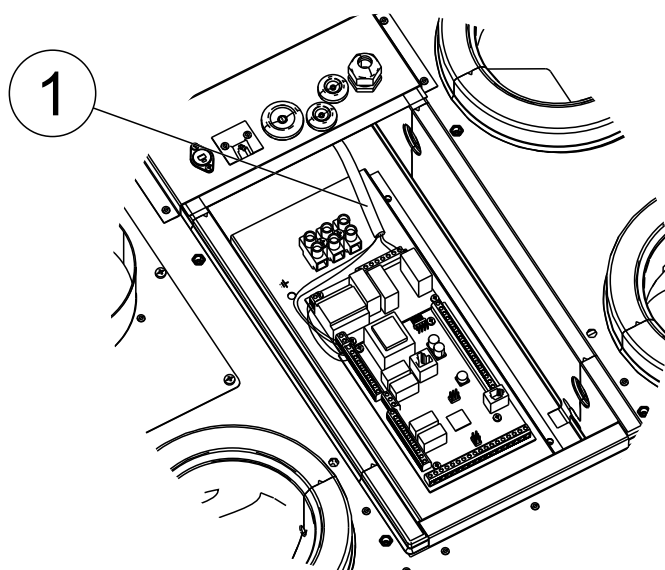

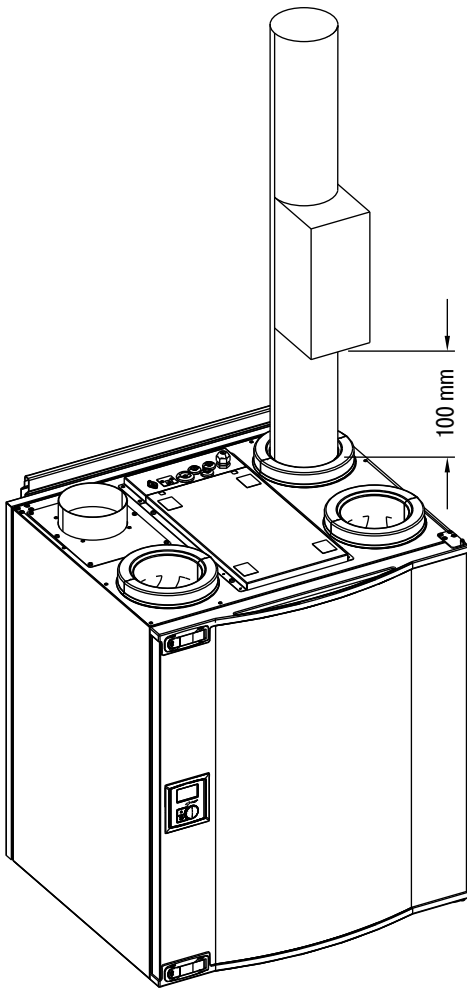

Fig. 10 VTC 200 with mounted pre-heater

Required distance between the pre-heater and the unit figure 10.

When the pre-heater is installed, the unit will self adjust to avoid going to defrost mode.

Table 2: Dimension table for pre-heater

Q l/s	Outdoor temperature °C			
	-10	-15	-20	-25
10	0,6 kW	0,6 kW	0,6 kW	0,6 kW
20	0,6 kW	0,6k W	0,6 kW	1,2 kW
30	0,6 kW	0,6 kW	1,2 kW	1,2 kW
40	0,6 kW	1,2 kW	1,2 kW	1,8 kW
50	1,2 kW	1,2 kW	1,8 kW	1,8 kW
60	1,2kW	1,2kW	1,8kW	1,8kW
70	1,2 kW	1,8 kW	1,8 kW	1,8 kW

8 Before starting the system

When the installation is finished, check that:

- The unit is installed in accordance with the instructions
- The unit is correctly wired
- Outdoor and exhaust air dampers and silencers are installed and that the duct system is correctly connected to the unit
- All ducts are sufficiently insulated and installed according to local rules and regulations
- Outdoor air intake is positioned with sufficient distance to pollution sources (kitchen ventilator exhaust, central vacuum system exhaust or similar)
- All external equipment is connected
- The unit is correctly configured and commissioned
- The week schedule and fan speed settings are correctly programmed.

9 Operation

9.1 Setting the temperature

The supply air temperature is set manually in steps of 1 K in the main menu display by choosing the temperature symbol.

If an electrical re-heater is installed the temperature setpoints are: 12-22 °C. For installed water re-heater the setpoints are: 12-40 °C.

If the re-heater is deactivated, the temperature steps are: 15-19 °C. Default value: 15.0 °C.

Each temperature step is illustrated by increasing the filling of the temperature symbol and the temperature is shown in the display

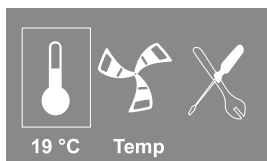

An unfilled temperature symbol will activate manual summer mode. See chapter 9.3

9.2 Manual setting of fan speed

It is possible, at any time, to manually set the fan speed in the main menu display. By choosing the fan symbol and confirming it is possible to increase or decrease the fan speed in the 4 steps: Off, Low, Nom and High.

By doing so, you override the programmed week schedule for the unit until the end of the present time period in the week program (chapter 6.6).



 **Warning**

The fan can be set to OFF by activating manual fan stop. See service menu overview (chapter 9.5) under functions.

9.3 Manual and automatic summer mode

Manual summer mode occurs if no temperature step is selected. The temperature symbol on the main menu is then completely empty.

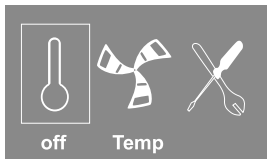

If the electrical re-heater is activated, it will switch off during manual summer mode. Manual summer mode goes automatically to step 1 (setpoint 12 °C) after two minutes if the supply air temperature is +5 °C or below.

If a water heater battery is installed and activated, the manual summer mode goes automatically to step 1 (setpoint 12 °C) if the outdoor air or supply air temperature is +5 °C or below.

The unit will automatically alternate between winter operation with heat recovery and summer operation without heat recovery.

9.4 Cool recovery

If the outdoor air is warmer than the extract air and the supply air is above the setpoint, cool recovery occurs. This condition blocks the heat regulation process.

9.5 Service menu overview

Enter the service menu by selecting the service symbol in the display.

Menu Level 1	Menu Level 2	Menu Level 3	Explanation
Service Password	Password Password XXXX Locked YES/NO		Enter the service level by typing 1111. Use the SELECTION knob for each digit and confirm with the ENTER button after each set digit. NO will unlock the system and allow parameter changes.
Service Change Password	Change password Actual XXXX New XXXX Confirm XXXX		Set new password if necessary. In case the new password would be forgotten or misplaced it's still possible to enter the service level by writing 8642. This overrides the earlier set password.
Service Filter period	Filter period Time to replace: 12month Reset NO/YES		Shows selected time interval between filter change. Set Reset of the filter period to YES after completed filter change. Set time between filter changes.
Service Time/Date	Time/Date YY/MM/DD Date: 12/09/12 Time: 10:00 Weekday: Sat		Shows current set date and time. Set Correct date and time.
Service Ext/Force Run	Ext/Force Run Minutes: 0 Fan speed: Nominal		Use this dialogue frame to program extended time you want the unit to work under operation conditions other than determined by the week schedule. Shows set time for extended/forced running. Shows Set fan speed. Set the time that the unit is to run in extended/forced mode. Value range: 0–240 minutes. Set the fan speed for this mode. Choose between Low, Nom or High. Default value: Nom.

Menu Level 1	Menu Level 2	Menu Level 3	Explanation
Service Week program	Week program Week program	Week program Day: MON Per 1: 07:00 16:00 Per 2: 00:00 00:00	Program how you want the unit to operate according to the week schedule. It's possible to set 2 periods per day. Set week day and time interval for the time you want the unit to be in ON mode.
	Week program Fan speed	Fan speed On level: low/nom/high/auto Off level: off/low/nom/high	Use this dialogue frame to determine the ON and OFF function for the fans in the week schedule. Set ON level. Choose between Low, Nom, High or Auto. Default value: Nom Set OFF level. Choose between OFF, Low, Nom or High. Default value: Low.
Service Fan speed log	Fan speed log Level: 1-5 Reset: NO/YES SF: 140 /140 EF: 140 /140		Use this dialogue frame to see how the fans have operated during the time (h) they have been active. The speeds are shown in 5 different levels: <ul style="list-style-type: none"> • Level 1: 0% • Level 2: 1 – 29% • Level 3: 30 – 44% • Level 4: 45 – 59% • Level 5: 60 – 100% Choose between the levels to see the time in hours the fans have been active in the different levels. Reset Yes resets the SF and EF time in the left column for all levels. The right column continues to count ahead and can not be reset. <hr/> Note: Factory reset (see Functions ->Factory reset) will not affect this function <hr/>

Menu Level 1	Menu Level 2	Menu Level 3	Explanation
Service Functions	Functions Heater/Cooler	Heater/Cooler Pre-heater: YES/NO Re-heater: None/Electrical/Water Cooler: None/Water	Use this dialogue frame to set up the unit for heating and/or cooling. Set Re-heater to None, Electrical or Water. Set Cooler to None or Water.
	Functions Frost protection	Frost protection Alarm limit: 7°C	Shows current set frost protection alarm limit in °C for the installed water coil. Set Alarm limit in °C. Default value: 7°C.
	Functions System curve	System curve EF: 1-10 SF: 1-20	This function is to compensate the flow values for different system pressures. See chapter 6.3
	Functions Fan control	Fan control Airflow Speed	Select the type of fan control you prefer. Fan control by l/s, m ³ /h or %
	Fan control Airflow	Airflow EF SF l/s Nom 50 50 High 72 72 Low 30 30	Use this dialogue frame to set the fan speed in l/s. The speed can be set individually for each fan EF : Extract fan, SF : Supply fan Set the fan speed for EF and SF for each step (Low, Nom, and High). System curve shall only be available in case a system with that type of fan control is used.
	Fan control Airflow unit	Airflow unit l/s / m ³ /h / %	Default value: l/s

Menu Level 1	Menu Level 2	Menu Level 3	Explanation
	Demand control	Demand control CO2 / RH Setpoint 0 ppm/0% RH P-Band 100 ppm/10%RH I-Time OFF	Demand control (menu choice or setpoint) shall only be available if CO2 or RH% sensors are detected. Those should not be needed to configure, once connected to the wireless gateway should just tell the unit (PCU-EC) there is a sensor available. Setpoint shall also be able to set to 0 to turn off demand control. Both types should be able to use at the same time, meaning 2 PI controllers. When demand control setpoint is configured, fans set to auto mode and regulate against the setpoint. The fan symbol should have the middle area empty, and the outer and inner filled. It should not be possible to change either.
	Fan control Speed	Speed % EF SF Nom 50 50 High 100 100 Low 25 25	Use this dialogue frame to set the fan speed in %. The speed can be set individually for each fan EF: Extract fan, SF: Supply fan Set the fan speed for EF and SF for each step (Low, Nom, and High).
	Functions Manual fan stop	Manual fan stop Allow manual fan stop Y/N	Set if it should be possible to turn off the fans in the unit manually from the control panel. Chose between Y and N . If Y is selected the fans can be turned off by turning the SELECTION knob to empty fan
	Functions Analog input	Analog input 1: SS 20.0 2: ETS 23.0 3: Unused 4: Unused/FPS 20.0 5: OS 10.5	Shows analogue inputs from active temperature sensors. SS: Supply air temp sensor. ETS: Extract air temp sensor. FPS: Frost protection sensor. OS: Outdoor air temp sensor.

Menu Level 1	Menu Level 2	Menu Level 3	Explanation
	<p>Functions</p> <p>Analog output</p>	<p>Analog output</p> <p>A01 auto/man/off A02 auto/man/off A03 auto/man/off</p>	<p>Shows current analogue outputs in 0–10 V to hot/cold water actuator or electrical re-heater and bypass damper.</p> <p>Set AO1 (Analogue output to hot water actuator or electrical re-heater) to auto, man or off. Default value: auto.</p> <p>Set AO2 (Analogue output to cold water actuator) to auto, man or off. Default value: auto.</p> <p>Set AO3 (Analogue output to bypass damper) to auto or man. Default is auto. Selecting man enables the user to manually control the actuator/damper with a 0–10 V signal. 0V completely closed and 10 V completely opened actuator/bypass damper. When used on the bypass damper the unit can be forced to go to summer mode operation (10 V).</p>
	<p>Functions</p> <p>Digital input</p>	<p>Digital input</p> <p>DI1 ON/OFF DI2 ON/OFF DI3 ON/OFF DI4 ON/OFF DI5 ON/OFF DI6 ON/OFF DI7 ON/OFF</p>	<p>Shows current setting of the digital inputs ON or OFF</p> <p>DI1: Fan configuration DI2: Fan configuration DI3: Fan configuration DI4: Heater deactivated DI5: Extended/forced running DI6: Bypass damper limit switch DI7: Home/leave</p>

Menu Level 1	Menu Level 2	Menu Level 3	Explanation
	<p>Functions</p> <p>Config DI 1-3</p>	<p>Config DI 1-3 Default: 1 SF high EF high 2 SF low EF low 3 SF high EF low</p>	<p>Use this dialogue frame to set how you want the fans to react to 3 different digital inputs when they are switched on (the settings in the column to the left are examples).</p> <p>Potential free switches need to be connected physically to terminals on the main print card to obtain the different functions. See the wiring diagram for more information.</p> <p>Set the supply air fan (SF) and extract air fan (EF) individually to off, low, nom or high for digital inputs 1-3</p>

Menu Level 1	Menu Level 2	Menu Level 3	Explanation
	<p>Functions</p> <p>DI 4-7</p>	<p>DI 4-7</p> <p>4 Stop heat 5 Ext run 6 Damper 7 Home/Leave</p>	<p>DI 4-7 are default set from factory and can't be changed by the user. Below follows a short description of each function.</p> <p>DI4: Makes it possible to disable the electrical re-heater. Activated input means that the electrical re-heater is deactivated.</p> <p>DI5: Activate the Extended/forced running function. The function overrides current set fan speed settings and runs according to the settings in <i>Service->Ext/Force run</i>. Choose between Low, Nom and High for this function. The input is calculated based on the signals from an impulse-switch. If a standard switch is used, the countdown of the set time starts when the switch is switched off.</p> <p>DI6: Bypass damper limit switch. Used by the system for the damper position.</p> <p>DI7: Activates low energy support control. Heat exchanger operating by the adjusted setpoint value and a active re-heater has support control for the lowest setpoint. (12 °C)</p> <p>The function is used when the building is uninhabited for a longer period.</p> <p>It is recommended to connect DI7 and DI1 or DI3 in parallel. If DI7 is activated, set the fans speed to min. Fan speed settings are done when configuring DI1/DI3.</p>

Menu Level 1	Menu Level 2	Menu Level 3	Explanation
	Functions Digital output	Digital output 1: SF 67% 2: EF 67% 3: Not used 4: ALARM Y/N 5: Dmp Y/N 6: Heater Y/N	Shows The current settings of digital outputs 1–6 (the settings in the column to the left are examples). 1: SF 67%: Current set speed of the supply air fan (shown as percentage of the maximum speed). 2: EF 67% Current set speed of the extract air fan (shown as percentage of the maximum speed). 4: Alarm Y/N: Indicates if the sum. alarm is active or not 5: Dmp OFF: Outdoor/exhaust air damper is on or off. 6: Heater Y/N: Indicates if the electrical pre-heater is active or not.
	External sensors	External sensors CO2: 0 ppm – RH: 0% –	Last valid value is presented for the bounded sensors. Highest actual sensor signal presented via –/modbus/wireless. Unbound sensor presented as – (none). Modbus sensors has priority over wireless sensors.

Menu Level 1	Menu Level 2	Menu Level 3	Explanation
	<p>Functions</p> <p>External DI</p>	<p>External DI</p> <p>Active Wireless: DI1/..DI20</p> <p>Assign to: -/DI- 5/DI7</p>	<p>External DI menu only available if one or several "Input modules" are bound to the system. Active wireless DI1-20 is depended on actual node for "Input module".</p> <p>Node shown in "Wireless" menu which node representing DI module inputs.</p> <p>Eg.</p> <p>Node 1 type: DI. Active wireless DI1 and DI2</p> <p>Node 2 type: DI. Active wireless DI3 and DI4</p> <p>Node 10 type: DI. Active wireless DI19 and DI20</p> <p>Active wireless DI1-20 are available to assign to DI1-5 and DI7 for the system in the air handling unit.</p> <p>DI6 is not available as selection, used by the system in the air handling unit.</p> <p>Unsigned DI is shown as – (none).</p> <p>To reset a previously assigned DI, select "–" and confirm the selection.</p>
	<p>Functions</p> <p>Wireless</p>	<p>External DI</p> <p>Note: 1 Type: None</p> <p>State: No Network</p> <p>Data: 0</p>	<p>Wireless system status.</p> <p>Node: Shows number of bound wireless module.</p> <p>Type: None/UI: User Interface (Control panel)/DI: Digital Input module/CO2: CO2 sensor module/RH: RH sensor module.</p> <p>State: No Network: No gateway connected to the system for air handling unit/Unbound: No bonded module/OK: Successful binding of module</p> <p>Data: The actual value from module/Comm fail: Communication failure, see manual for actual module for troubleshooting.</p> <p>To reset all bound nodes, see user manual for Gateway Wireless.</p>

Menu Level 1	Menu Level 2	Menu Level 3	Explanation
	Functions Defrosting	Defrosting Mode 1-5 Allow unbalance YES (Active defrosting cycle)	Use this dialogue frame to set how aggressive you want the defrosting function to operate (see chapter 6.5).
	Functions Modbus	Modbus Address 1 Baud 9600/19200 Parity None/Even/Odd	Information about Modbus communication and variables can be found in the Modbus user manual for residential units in the online catalogue at
	Functions Factory reset	Factory reset Really reset? YES/NO	Use this dialogue frame to return to factory settings. Set YES or NO <hr/> Note: This will erase all your personal settings that have been done for the unit.
Service Language	Language Language ENGLISH		Use this dialogue frame to return to select your local language. Set Language by turning the SELECTION knob.
Service Versions	Version SAVE VTC 200 CD EC Appl. xxx xxx Boot xxx xxx		Shows current software versions <hr/> Note: The software versions are just an example and may differ in a specific unit.
Service Alarms	Alarms Fan Y Frost N Damp Y Pb Fail N Temp N Filter Y		Shows the alarm list and which alarms that have been triggered (indicated by Y). See alarm list (chapter 10.4.1)

10 Service

10.1 Warnings

Danger

- Make sure that the mains supply to the unit is disconnected before performing any maintenance or electrical work!
- All electrical connections and maintenance work must be carried out by an authorized installer and in accordance with local rules and regulations.

Warning

- The system should operate continuously, and only be stopped for maintenance/service
- Although the mains supply to the unit has been disconnected there is still risk for injury due to rotating parts that have not come to a complete standstill
- Beware of sharp edges during maintenance. Use protective gloves
- Make sure that filters are mounted in their place before running the system
- This product must only be operated by a person which has suitable knowledge or education within this field or carried out with the supervision of a suitably qualified person.

10.2 Internal components

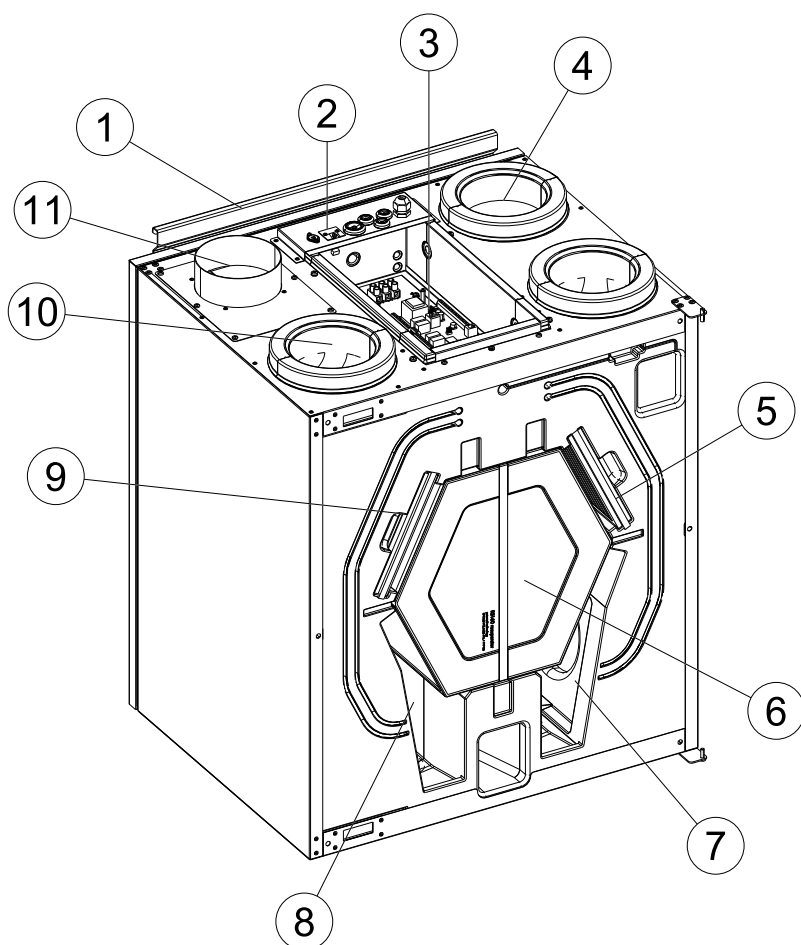

Fig. 11 Internal components

Position	Description
1	Mounting bracket
2	External connections
3	Main print card
4	Outdoor air temperature sensor
5	Filter, supply air
6	Heat exchanger
7	Fan, extract air
8	Fan, supply air
9	Filter, extract air
10	Supply air temperature sensor
11	Extract air temperature sensor

10.3 Components description

10.3.1 Fans

The fans have external rotor motors of EC type which can be steplessly controlled individually 20–100%. The motor bearings are life time lubricated and maintenance free. It is possible to remove the fans for cleaning, see “User Manual” for more information.

10.3.2 Filters

The factory installed filters are of filter quality G4 for the supply air and G4 for the extract air filter. The filters need to be replaced when polluted. New sets of filters can be acquired from your installer or wholesaler.

Filter quality F7 can be installed for supply air filtering.
The filter type is labelled on the top of the filter

Note:

If type F7 filters are used instead of G4 , the system curve for Supply Fan (SF) must be changed:

For F7 type filter: 11–20, for G4 type filter: 1–10. See chapter 6.3.

10.3.3 Heat exchanger

SAVE VTC 200 is equipped with a counter flow plate heat exchanger. Required supply air temperature is therefore normally maintained without adding additional heat.

10.3.4 Print card

The main print card controls the functions and set temperatures of the unit.

It is possible to connect external accessories to terminals on the print card and also communication to BMS (Building Management System) Modbus communication via RS-485. See wiring diagram for more information.

10.3.5 Temperature sensors

Four temperature sensors (NTC, 10 k Ω at 25°C) are included in the unit from factory and positioned in the corresponding air chambers.

The sensors are connected to the main print card. See wiring diagram for more information.

10.3.6 Electrical pre-heater battery

An optional pre-heater battery can be connected to the outdoor air duct. Pre-heater function is regulated by the integrated outdoor temperature sensor (OS) and related to selected defrosting level.

10.3.7 Electrical re-heater battery

An optional re-heater battery can be connected to the supply air. The re-heater is controlled by the analog output WH (0-10V) and switches off if one or more of the following conditions are met:

1. If the supply air sensor is in error state.
2. If the supply air fan is not running.
3. If the heater is set to disabled in the menu.

The supply air sensor (SS) at AI 1 must be replaced with a duct sensor which can be acquired as an accessory. Sensor type: TG-K360. See wiring diagram for more information.

10.3.8 Water re-heater battery

A water re-heater battery (optional), which can be acquired as an accessory, can be controlled by the analog output WH (0-10 V DC). The water heater uses AI 4 for frost protection.

The frost protection sensor should then be a strap on surface sensor situated on the return water tube. Sensor type: TG-A130

The supply air sensor (SS) at AI 1 must be replaced with a duct sensor which can be acquired as an accessory. Sensor type: TG-K360. See wiring diagram for more information.

Only electrical or water re-heater is allowed, i.e. if a water re-heater is selected, the electrical re-heater is deactivated and vice versa.

Note:

If a water re-heater battery is installed we strongly recommend you to also install an outdoor air damper with a spring return actuator.

10.3.9 Water cooler

A water cooler (optional) can be acquired as an accessory and be controlled by the unit. If a water cooler is installed the supply air sensor (SS) at AI 1 must be replaced with a duct sensor which can be acquired as an accessory. Sensor type: TG-K360. See wiring diagram for more information.

10.4 Trouble shooting

A warning triangle with text in the display indicates an alarm. Turn menu selector to the warning triangle and press confirm twice to view the alarm.



If problems should occur, please check the items below before calling your service representative.

Malfunction	Action
Fans do not start	<ol style="list-style-type: none"> 1. Check the display for alarms. 2. Check fuse for main power supply in the distribution box for the building and all the quick connectors are connected in the unit (quick connectors for supply and extract air fans). 3. Check that the week program is in ON mode. The week program might be in OFF mode with the fan speed set to OFF (chapter 6.6) 4. Check if one of the digital inputs 1–3 (DI 1–3) is active and set to off. This would force one or both fans to stop depending on the setup (chapter 9.5).
Reduced airflow	<ol style="list-style-type: none"> 1. Check the display for alarms. 2. Check setting of fan speed in the control panel (chapter 6.1.1). 3. Check week program (chapter 6.6). 4. Check if one of the digital inputs 1–3 (DI 1–3) is active and set to off. This would force one or both fans to stop depending on the setup (chapter 9.5). 5. Check if auto mode is active. Auto mode reduces the airflow if actual value from external sensor/sensors is lower than demand control set-point. 6. Check filters. Change of filters required? 7. Check diffuser/louver openings. Cleaning of diffusers/louvres required? 8. Check fans and heat exchange block. Cleaning required? 9. Check if the buildings air intake and roof unit (exhaust) have been clogged. 10. Check visible duct runs for damage and/or build up of dust/pollution.
The unit cannot be controlled (control functions are stuck)	<ol style="list-style-type: none"> 1. Reset control functions by pulling out the main power supply plug for 20-30 seconds. 2. Check the modular contact connection between the control panel and the main print card.

<p>Low supply air temperature</p>	<ol style="list-style-type: none"> 1. Check the display for alarms. 2. Check set supply air temperature in the control panel. 3. Check the analogue inputs in the service menu to verify that the temp sensors are ok (chapter 9.5). Go to <code>Functions > Analogue input</code> and verify the temperature readings from the temp sensors. 4. Check that the Home/Leave function is disabled DI 7. 5. Check if the over heat protection thermostat is still alert. If necessary, reset by pressing the reset button on the optional duct heaters. 6. Check if digital input 4 (DI 4) is set to off. This would force the electrical re-heater battery to be switched off (chapter 9.5) 7. Check if the extract filter must be changed. 8. At very cold outdoor conditions an electrical pre heating battery might be necessary. This can be acquired as an accessory. 9. Check the balance between the supply and extract air
<p>Noise/vibrations</p>	<ol style="list-style-type: none"> 1. Clean fan impellers. 2. Check that the screws holding the fans are tightened. 3. Check that the anti vibration pads are fitted at the bottom back of the unit.

10.4.1 Alarm list

Alarm	Explanation	Do the following
Fan	Indicates error on either supply or extract air fan.	<p>The alarm is displayed in the control panel.</p> <p>Check that quick connectors are connected for the both fans.</p> <p>Contact your installation company or place of purchase.</p>
Frost	Indicates triggered frost protection (in case of installed water heating battery) or triggered overheat protection (in case of installed electric re-heater battery).	<p>A triggered frost protection alarm results in the following:</p> <ul style="list-style-type: none"> • Both fans stop. • Outdoor and exhaust air dampers closed. • Water valve opens completely (10 V signal goes out to the actuator). <p>The unit will restart once the water temperature reaches +5°C above the set frost protection temperature.</p> <p>A triggered over heat protection for a electrical re-heater gives an alarm in the control panel.</p> <p>If the supply air temperature falls below +5 C°.</p> <p>For reset see electrical re-heater manual.</p> <p>If the problem continues contact your installation company or place of purchase.</p>
Damp	Indicates malfunction in bypass damper	<p>The alarm is displayed in the control panel.</p> <p>The unit will not be able to use the bypass damper for temperature control.</p>
PbFail	Error in connection with relay card for the electrical pre-heater (if installed and activated).	<p>The alarm is displayed in the control panel.</p> <p>The heater will not be activated.</p> <p>If triggered overheat protection in the pre-heater, see electrical pre-heater manual.</p>
Temp	Malfunction in one or more of the temperature sensors.	<p>The alarm is displayed in the control panel.</p> <p>Contact your installation company or place of purchase.</p>
Filter	Time for filter change.	<p>The alarm is displayed in the control panel.</p> <p>Change filter according to instructions in the user guide.</p>

Systemair AB reserves the right to make changes and improvements to the contents of this manual without prior notice.



Systemair AB
Industrivägen 3
SE-739 30 Skinnkatteberg, Sweden

Phone +46 222 440 00

Fax +46 222 440 99