

# Topvex SF02-SF12

## Air Handling Unit



### **GB** Installation instructions

## Contents

1 Declaration of Conformity .....	1
2 Warnings.....	2
3 Product information.....	2
3.1 General .....	2
3.2 Technical data.....	3
3.2.1 Dimensions and weight .....	3
3.2.2 Electrical data.....	5
3.3 Transport and storage.....	6
4 Installation.....	6
4.1 Unpacking.....	6
4.2 Where/how to install .....	6
4.3 Installing the unit .....	7
4.3.1 Mounting brackets.....	7
4.3.2 Installing procedure.....	8
4.4 Connection .....	9
4.4.1 Ducting.....	9
4.4.2 Electrical connection box, components .....	10
4.4.3 External connections .....	11
4.4.4 Temperature sensor, supply air and outdoor air damper.....	12
4.4.5 Extract fan.....	12
4.4.6 Electrical heater .....	13
4.4.7 Hot water heater .....	13
5 BMS Connection.....	14
6 Control panel.....	14
6.1 General information .....	14
6.2 Dimensions.....	15
6.3 Installation .....	15
7 Additional Equipment .....	16

# 1 Declaration of Conformity

## Manufacturer



Systemair Sverige AB  
 Industrivägen 3  
 SE-739 30 Skinnskatteberg SWEDEN Office:  
 +46 222 440 00 Fax: +46 222 440 99

hereby confirms that the following products:

Air handling units

<b>EL</b>	Topvex SF02	Topvex SF03	Topvex SF04	Topvex SF06		
<b>HWL</b>	Topvex SF02	Topvex SF03	Topvex SF04	Topvex SF06	Topvex SF08	Topvex SF12
<b>HWH</b>	Topvex SF02	Topvex SF03	Topvex SF04	Topvex SF06	Topvex SF08	Topvex SF12

(The declaration applies only to product in the condition it was delivered in and installed in the facility in accordance with the included installation instructions. The insurance does not cover components that are added or actions carried out subsequently on the product)

**Comply with all applicable requirements in the following directives and regulations**

**Machinery Directive  
2006/42/EC**

**Low Voltage Directive  
2006/95/EC**

**EMC Directive 2004/108/EC**

**Ecodesign Directive 2009/125/EC**

*327/2011 Requirements for fans  
1253/2014 Requirements for ventilation units*

**The following harmonized standards are applied in applicable parts:**

EN ISO 12100:2010	Safety of machinery - General principles for design - Risk assessment and risk reduction
EN 13857	Safety of machinery – Safety distances to prevent hazard zones being reached by upper or lower limbs
EN 60204-1	Safety of machinery – Electrical equipment of machines – Part 1: General requirements
EN 60335-1	Household and similar electrical appliances – Safety Part 1: General requirements
EN 60335-2-40	Safety of household and similar electrical appliances - Part 2-40: Particular requirements for electrical heat pumps, air-conditioners and dehumidifiers
EN 50106:2007	Safety of household and similar appliances – Particular rules for routine tests referring to appliances under the scope of EN 60 335-1 and EN 60967
EN 60529	Degrees of protection provided by enclosures (IP Code)
EN 62233	Measurement methods for electromagnetic fields of household appliances and similar apparatus with regard to human exposure
EN 61000-6-2	Electromagnetic compatibility (EMC) – Part 6-2: Generic standards – Immunity for industrial environments
EN 61000-6-3	Electromagnetic compatibility (EMC) – Part 6-3: Generic standards – Emission standards for residential, commercial and light-industrial environments

The complete technical documentation is available.

Skinnskatteberg, 10-11-2015



Mats Sándor  
 Technical Director

## 2 Warnings

The following admonitions will be presented in the different sections of the document.

### **Danger**

- Make sure that the Mains supply to the unit is disconnected before performing any maintenance or electrical work!
- All electrical connections must be carried out by an authorized installer and in accordance with local rules and regulations.

### **Warning**

- The door handles are only intended to be used during the installation and service. These must be removed before the unit is put into operation to ensure the required level of safety for the unit.  
The unit must be duct connected or in some other way provided with protection so that it is not possible to come in contact with the fans through the duct connections
- The unit is heavy. Be careful during transport and mounting. Risk of injury through pinching. Use protective clothing.
- Beware of sharp edges during mounting and maintenance. Make sure that a proper lifting device is used. Use protective clothing.
- The units electrical connection to the mains supply must be preceded by an all pole circuit breaker with a minimum 3 mm gap.

### **Caution**

- If the unit is installed in a cold place make sure that all joints are covered with insulation, and tape well
- Duct connections/duct ends should be covered during storage and installation
- Do not connect tumble dryers to the ventilation system
- Take care not to damage the water battery when connecting water pipes to connectors. Use a spanner to tighten the connection.

## 3 Product information

### 3.1 General

This installation manual concerns air handling unit type Topvex SF manufactured by Systemair Sverige AB. The units include the following model options:

- **Model:** Topvex SF02, Topvex SF03, Topvex SF04, Topvex SF06, Topvex SF08 and Topvex SF12.
- **Heating coil:** **EL** (Electric), **HWL** (Water coil, low power), **HWH** (Water coil, high power).
- Stepless voltage control. VAV available as accessory (VAV– Variable Air Volume = Constant duct pressure control).

This manual consists of basic information and recommendations concerning the design, installation, start-up and operation, to ensure a proper fail-free operation of the unit.

The key to proper and safe operating of the unit is to read this manual thoroughly, use the unit according to given guidelines and follow all safety requirements.

## 3.2 Technical data

### 3.2.1 Dimensions and weight

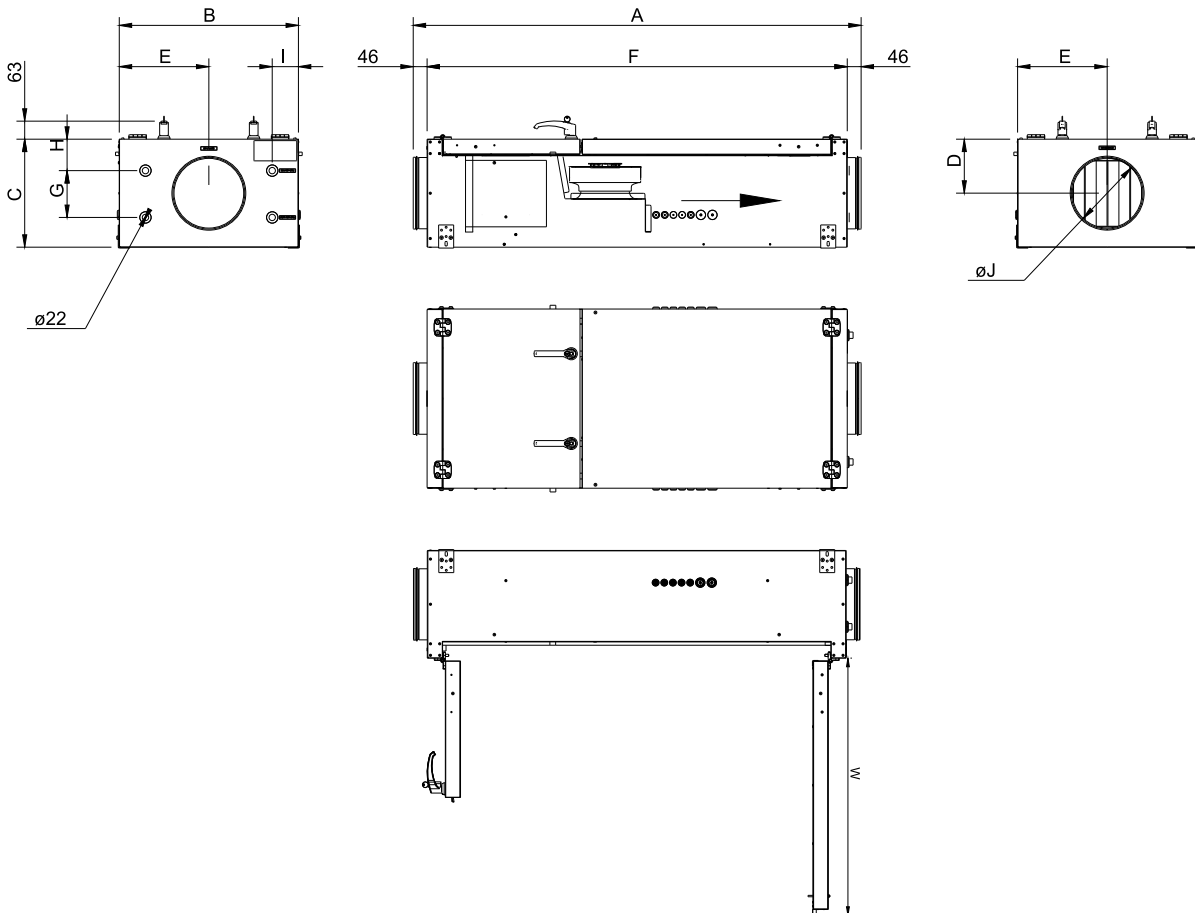

**Fig. 1 Topvex SF02-Topvex SF03 Dimension (mm)**

Model	A	B	C	D	E	F
Topvex SF02	1463	557	321	161	278	1366
Topvex SF03	1550	619	373	187	310	1454

Model	G	H	I	øJ	W	Weight, kg
Topvex SF02	150	88	92	200	844	55
Topvex SF03	162	109	92	250	893	62

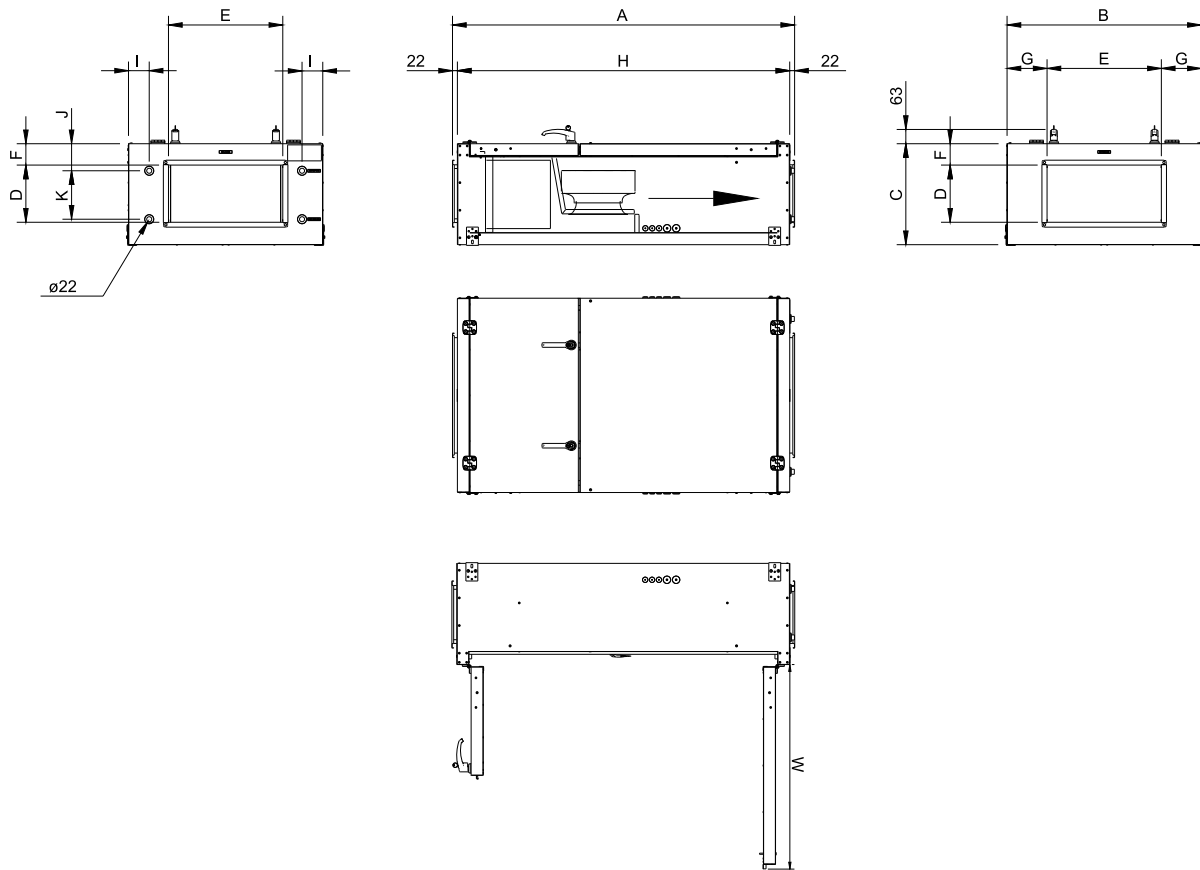

**Fig. 2 Topvex SF04-Topvex SF12 Dimensions (mm)**

Model	A	B	C	D	E	F
Topvex SF04	1497	749	373	200	400	89
Topvex SF06	1497	849	441	250	500	94
Topvex SF08 <sup>1</sup>	1497	903	545	300	600	125
Topvex SF12 <sup>1</sup>	1546	1011	545	400	700	74

1. size S08 and S12 only in HW

Model	G	H	I	J	K	W	Weight, kg
Topvex SF04	175	1454	90	109	162	894	74
Topvex SF06	175	1454	91	119	212	894	81
Topvex SF08 <sup>1</sup>	152	1454	90	145	262	894	98
Topvex SF12 <sup>1</sup>	152	1503	92	94	362	894	109

### 3.2.2 Electrical data

Model	Fans (W tot.) 230V 1~ and 400 V 3N~	EI Heating battery (kW tot.)	Fuse (mains) (A) for 230 V 1~ and 400 V 3~
Topvex SF02 EL 4,5 kW	168	4,5	3x16
Topvex SF02 EL 9 kW	168	9	3x16
Topvex SF02 HWL, HWH	168	-	10
Topvex SF03 EL 7,7 kW	169	7,7	3x16
Topvex SF03 EL 15,3 kW	169	15,3	3x25
Topvex SF03 HWL, HWH	169	-	10
Topvex SF04 EL 10,5 kW	540	10,5	3x20
Topvex SF04 EL 20,9 kW	540	20,9	3x40
Topvex SF04 HWL, HWH	540	-	10
Topvex SF06 EL 13,7 kW	483	13,7	3x25
Topvex SF06 EL 27,5 kW	483	27,5	3x63
Topvex SF06 HWL, HWH	483	-	10
Topvex SF08 HWL, HWH	756	-	10
Topvex SF12 HWL, HWH	1289	-	3x10

## 3.3 Transport and storage

Topvex SF is delivered in one piece standing on a pallet for easy transportation using a forklift. The unit should be stored and transported in such a way that it is protected against physical damage that can harm panels, handles, display etc. It should be covered so that dust, rain and snow cannot enter and damage the unit and its components. The appliance is delivered complete with all necessary components, wrapped in plastic on a pallet for easy transportation.

When transporting the Topvex SF units use a forklift placed on the gable of the unit.

---

### Note:

Necessary parts like control panel, supply air sensor, handles, mounting brackets and electrical safety switch are placed inside the unit. The unit must not be put into operation before the enclosed parts are removed and installed properly.

---

#### **Warning**

The unit is heavy. Be careful during transport and installation. Risk of injury through pinching. Use protective clothing.

## 4 Installation

### 4.1 Unpacking

Verify that all ordered equipment are delivered before starting the installation. Any discrepancies from the ordered equipment must be reported to the supplier of Systemair products.

### 4.2 Where/how to install

Topvex SF are meant for indoor installation. The electronic components should not be exposed to lower temperature than 0° C and higher than +50° C.

If the unit is installed in a cold place it is important that the unit is not shut-off by the main switch. As long as the main voltage is on the electrical cabinet will be kept warm also in cold climates. Although the unit is turned off by the control system the current is on.

When choosing the location it should be kept in mind that the unit requires maintenance regularly and that the inspection doors should be easily accessible. Leave free space for opening the doors and for taking out the main components (chapter 3.2.1.)

The outdoor air intake of the building should if possible be put in the northern or eastern side of the building and away from other exhaust outlets like kitchen fan outcasts or laundry room outlets.

#### **Warning**

- The door handles are only intended to be used during the installation and service. Handles must be removed before the unit is put into operation to ensure the required level of safety for the unit.
- The unit must be duct connected or in some other way provided with protection so that it is not possible to come in contact with the fans through the duct connections



## 4.3 Installing the unit

### Caution

Make sure that the hatch to the electrical connection box doesn't fall down during installation in false ceiling.

The unit can be installed in the positions shown in figure 3.

When the HW units are mounted horizontally on a wall, always make sure that the water pipe connections are above the battery, so the HW battery can be properly de-aired. By unscrewing four screws the HW battery can easily be rotated.

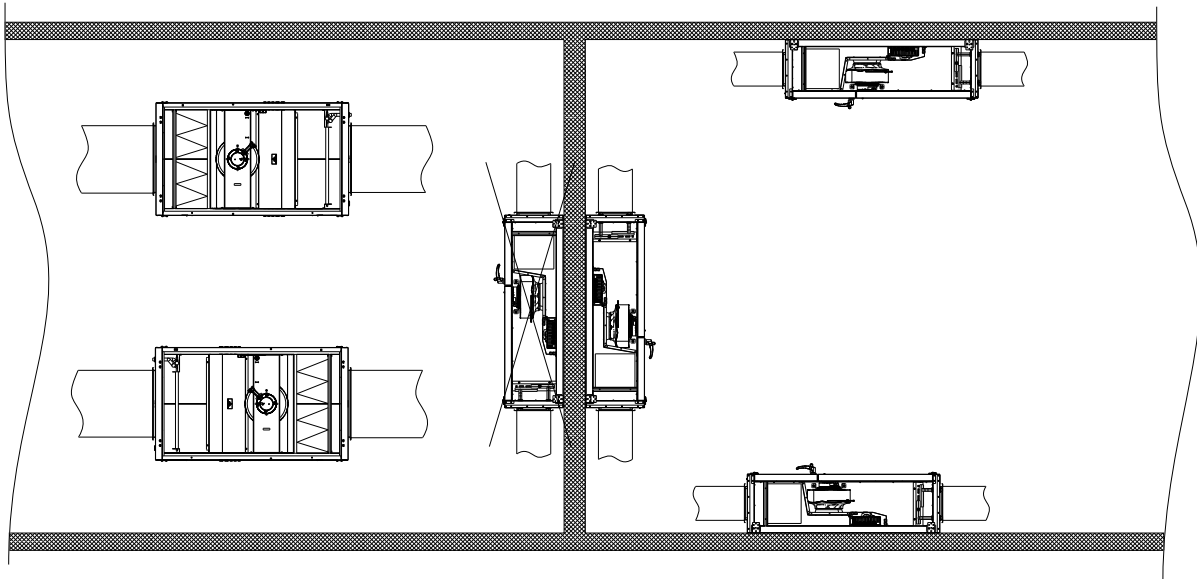

**Fig. 3 Mounting of HW units**

### 4.3.1 Mounting brackets

Together with the Topvex SF unit follows 4 mounting brackets that allows the unit to be mounted according to illustration figure 3 and figure 4.

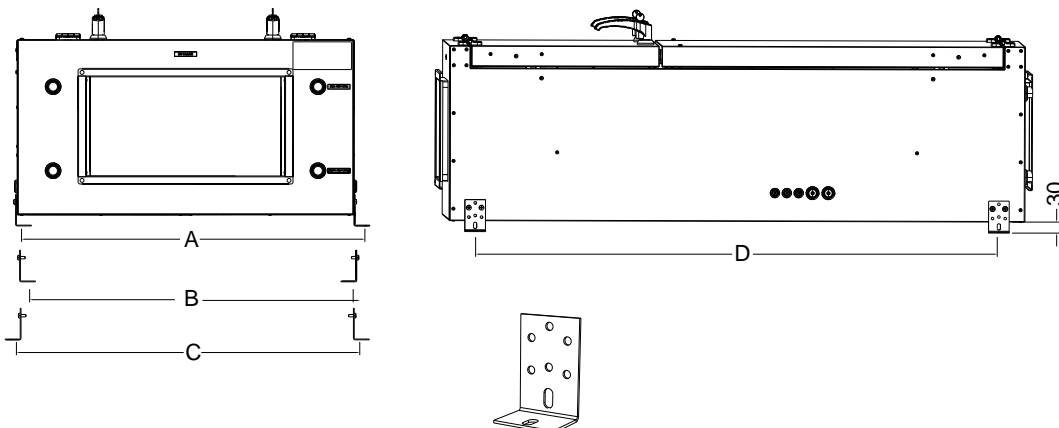

**Fig. 4**

Model	A	B	C	D
Topvex Topvex SF02EL/HW	563	523	603	1235
Topvex Topvex SF03 EL/HW	626	586	666	1322

Model	A	B	C	D
Topvex Topvex SF04 EL/ HW	756	716	796	1322
Topvex Topvex SF06 EL/ HW	856	816	896	1322
Topvex Topvex SF08 HW	911	871	951	1322
Topvex Topvex SF12 HW	1017	977	1057	1371

## 4.3.2 Installing procedure

1

Prepare the surface where the unit is to be mounted. Make sure that the surface is flat, levelled and that it carries the weight of the unit. Perform the installation in accordance with local rules and regulations.

2

Lift the unit in place.



### Warning

Beware of sharp edges during mounting and maintenance. Make sure that a proper lifting device is used. Use protective clothing.

3

Connect the unit electrically to the mains through the all pole circuit breaker (safety switch), which is enclosed inside the unit on delivery. The wiring is led directly to the electrical connection box.

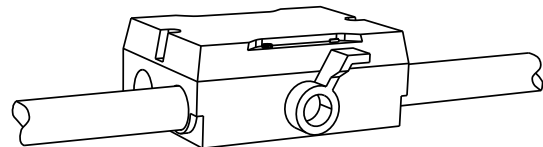

See enclosed wiring diagram, and chapter 4.4.3 for more information.

### Warning

The units electrical connection to the mains supply must be preceded by an all pole circuit breaker with a minimum 3 mm gap.



### Danger

- Make sure that the Mains supply to the unit is disconnected before performing any maintenance or electrical work!
- All electrical connections must be carried out by an authorized installer and in accordance with local rules and regulations.

## 4.4 Connection

### 4.4.1 Ducting

Air to and from the unit is led through a duct system. To ensure long life and satisfactory cleaning possibilities, ducts made of galvanised steel are highly recommended.

To obtain low energy consumption and required airflow, the duct system should be commissioned for low air speeds and low pressure drop.

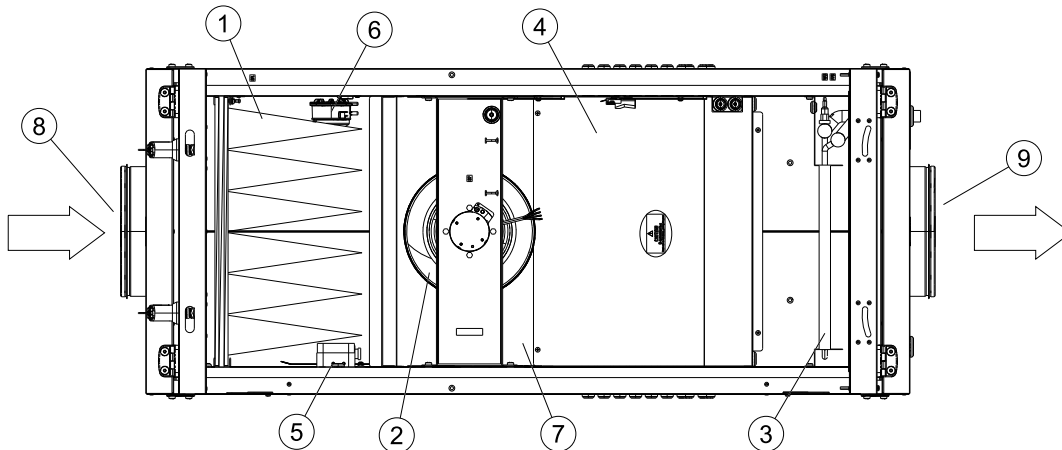

**Fig. 5 HW unit**

1	Filter, supply air
2	Fan, supply air
3	Heater, electrical or water
4	Electrical connection box
5	Pressure guard filter
6	Air flow sensor (only EL units)
7	Outdoor air sensor
8	Duct connection, outdoor air
9	Duct connection, supply air

#### Note:

Duct connections/duct ends should be covered during storage and installation

Grilles for intake/roof units must be installed according to building regulations in force.

Assemble the unit in the direction of airflow.

Secure all joints between ducting and the Topvex SF unit accurately using a minimum of 4 rivets per joint (circular ducts) and 4 M8 bolts per joint (rectangular ducts). Rectangular ducts requires sealing strips or sealing compound to ensure the air tightness.

#### **Caution**

To avoid fan noise being transferred via the ducting system, mufflers should be installed on supply air.

#### Note:

If the unit is installed in a cold place make sure that all joints are covered with insulation, and tape well.

## 4.4.2 Electrical connection box, components

### Danger

- Make sure that the Mains supply to the unit is disconnected before performing any maintenance or electrical work!
- All electrical connections must be carried out by an authorized installer and in accordance with local rules and regulations.

### Caution

Be careful so the hatch doesn't fall down if the unit is false ceiling mounted.

Topvex SF is equipped with a built in regulator and internal wiring.

Loosen the 4 screws to remove the hatch to the electrical connection box.

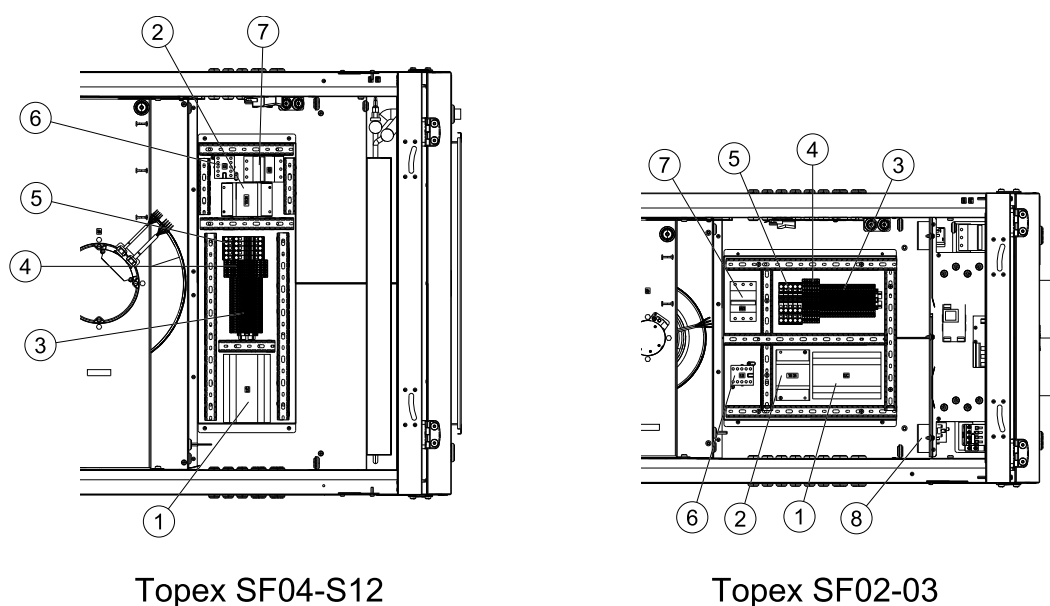

Topvex SF04-S12

Topvex SF02-03

**Fig. 6 Connection box**

Position	Description
1	Regulator E283 WEB
2	Transformer 230/24V AC
3	Terminals for internal and external components
4	Terminals for internal wiring
5	Terminals for mains supply to the unit
6	Contactora (K2) On/Off Pump control water (HW units only, not present in EL-units)
7	Automatic fuse
8	Reset for overheat protection (only EL units)

## 4.4.3 External connections

Terminal block		Description (GB)	Remark
	PE	Ground	
N	N	Earthed neutral (supply voltage)	
L1	L1	Phase (supply voltage)	Used for phase 230V 1~ if the unit has this mains supply 400V 3~
L2	L2	Phase (supply voltage)	400V 3~
L3	L3	Phase (supply voltage)	400V 3~
1	G	Mains supply (Water valve actuator)	24V AC
2	G0	Reference (Water valve actuator)	24V AC
10	DO ref	DO reference	G (24V AC)
12 <sup>1</sup>	DO 2	Outdoor/Exhaust air damper	24V AC Max. 2,0 A continuous load
WP	L1	Circulation pump hot water system	230V AC
13 <sup>1</sup>	DO 3	Activate cooling	
14 <sup>1</sup>	DO 4	Sum alarm	24 VAC
15 <sup>1</sup>	DO 5	Start external extract fan	24 VAC
30	AI ref	Supply air sensor reference	Neutral
31	AI 1	Sensor supply air	
40	Agnd	UI reference	Neutral
41 <sup>2</sup>	UAI 1/(UDI 1)	Pressure transmitter extract air	
42 <sup>2</sup>	UAI 2/(UDI 2)	Pressure transmitter supply air	
44	UAI 3/(UDI 3)	Frost protection sensor water heating battery	Use terminal 40 as reference
4 <sup>3</sup>	DI ref	External function reference	+ 24V DC
50/60/B	B	Exo-line B	Modbus, Exo-line connection
51/61/A	A	Exo-line A	Modbus, Exo-line connection
52/62	N	Exo-line N	Modbus, Exo-line connection
74 <sup>3</sup>	DI 4	Extended running	Normally open contact Use terminal 4 as reference
75 <sup>3</sup>	DI 5	Fire alarm	Normally open contact Use terminal 4 as reference
76 <sup>3</sup>	DI 6	External stop	Normally open contact Use terminal 4 as reference
90	Agnd	AO Reference	Neutral
91	AO 1	Control signal, water heating	0–10V DC
93	AO 3	Control signal, cooling	0–10V DC
94	A0 4	Control signal, external extract fan (optional) chapter 4.4.5	0-10V DC

1. *Maximum current load for all DO combined: 8A*
2. *Connection to external pressure sensor in case of pressure controlled unit (VAV)*
3. *These inputs may only be wired to voltage free contacts*

## 4.4.4 Temperature sensor, supply air and outdoor air damper

Mount the enclosed duct sensor in the supply air duct.

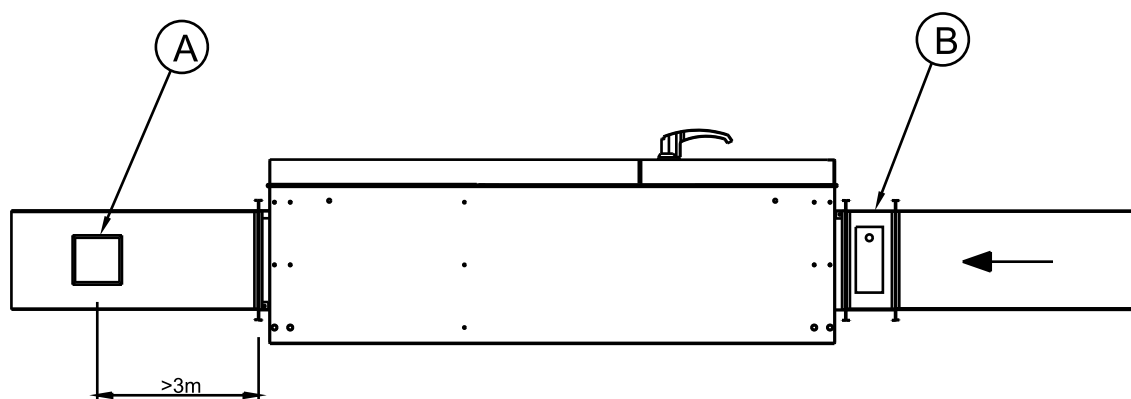

**Fig. 7 Temp sensor and damper**

A	Sensor, supply air
B	Motorized damper, outdoor air (accessory)

The damper (accessory) is also preventing the hot water battery from freezing by closing when the returning water in the battery is below a set temperature, +8 °C, alternatively if the supply air temperature drops below a set temperature (adjustable).

## 4.4.5 Extract fan

Extract fan can be connected to the unit and be operated parallel with the supply fan. The extract fan can be controlled in two ways.

- Use the pre-configured digital output to activate the extract fan DO 5. The output is active when the supply fan in the unit is running.

**Table 1: From External connection**

10	DO ref	DO reference	G (24V AC)
12	DO 2	Outdoor/Exhaust air damper	24V AC
1			Max. 2,0 A continuous load
WP	L1	Circulation pump hot water system	230V AC
13 <sup>1</sup>	DO 3	Activate cooling	
14 <sup>1</sup>	DO 4	Sum alarm	24 VAC
15 <sup>1</sup>	DO 5	Start external extract fan	24 VAC
90	Agnd	AO Reference	Neutral
91	AO 1	Control signal, water heating	0–10V DC
93	AO 3	Control signal, cooling	0–10V DC
94	AO 4	Control signal, external extract fan (optional) chapter 4.4.5	0-10V DC

<sup>1</sup>Maximum current load for all DO combined: 8A

- Setup a 0-10V DC analog output to control extract fan e.g EC fans, frequency inverters or other speed controllers.

**Table 2: From Menu overview (Operating and Maintenance Instruction)**

→ Access rights	→ Log on	Log on Enter password xxxx Actual level: None	<b>Log on</b> to service level by entering a 4-digit code. After reaching the desired level go back with "LEFT" arrow (press 2 times) on the control panel.  Standard code from factory to enter service level is 2222. Back to operator level: 1111. To enter Admin level code: 3333.
Darker gray area, log in to "Administrator level" code 3333			
→ Configuration	→ Inputs/Outputs	AO→ ↓ AO4	<b>Set to EAF</b>  AO4 Sign: EAF Auto Value: 0.0 V
→ Air Control			Set outputs %

The extract fan **must** be equipped with protection to stop the fan from overheating, an alarm signal can be wired back to the controller

---

**Note:**

See Corrigo manual-Ventilation application for more information.

---

### 4.4.6 Electrical heater

The heating coil is located after the fan and the material is stainless steel. The electrical heating coil has both automatic and manual overheating protection. The power demand of the electrical heating coil is controlled by a triac power regulator (Pulser) according to the desired supply air temperature that is set in the control panel.

### 4.4.7 Hot water heater

The hot water coil is located after the fan. The coil is mounted for easy connection through the short side of the unit. At the same time, it is designed in such a way that it is easy to access the pipe connections. The material is copper piping with a frame of galvanized sheet steel and aluminum fins.

The coil has a venting nipple and one immersion thermostat as frost guard. If the temperature drops and there is a risk of freezing (outlet water temperature below 8 °C) the water flow is maintained (the magnetic valve will open fully), the fan stops and the outdoor air damper, accessory, closes instantaneously

## 5 BMS Connection

### BMS Connection

Communication possibilities for controller E283 WEB.

- RS485(Modbus): 50-51-52 or 60-61-62
- RS485(Exoline): 50-51-52-53 or 60-61-62-63
- TCP/IP Exoline
- TCP/IP Modbus
- TCP/IP WEB
- BACnet/IP

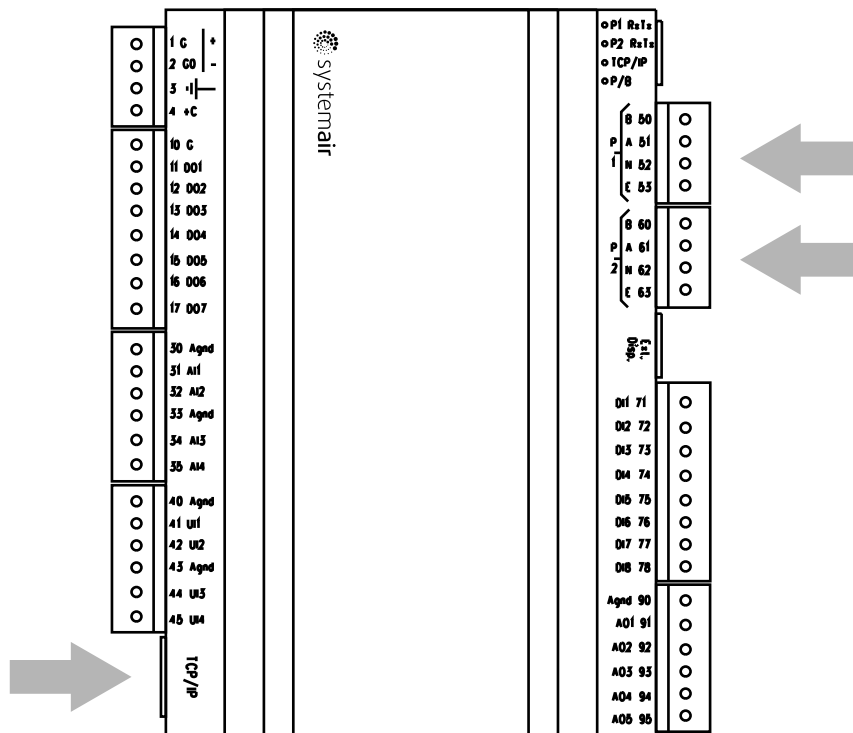

Fig. 8 BMS connection on the controller

## 6 Control panel

### 6.1 General information

The control panel is delivered connected to the Corrigo control unit situated in the electrical connection box. Cable length is 10 m. In case the control panel needs to be detached from the signal cable it is possible to loosen the wires on the back of the control panel (figure 10).

A set of self-adhesive magnet strips are included in the package to facilitate installation on a metal surface.



## 6.2 Dimensions

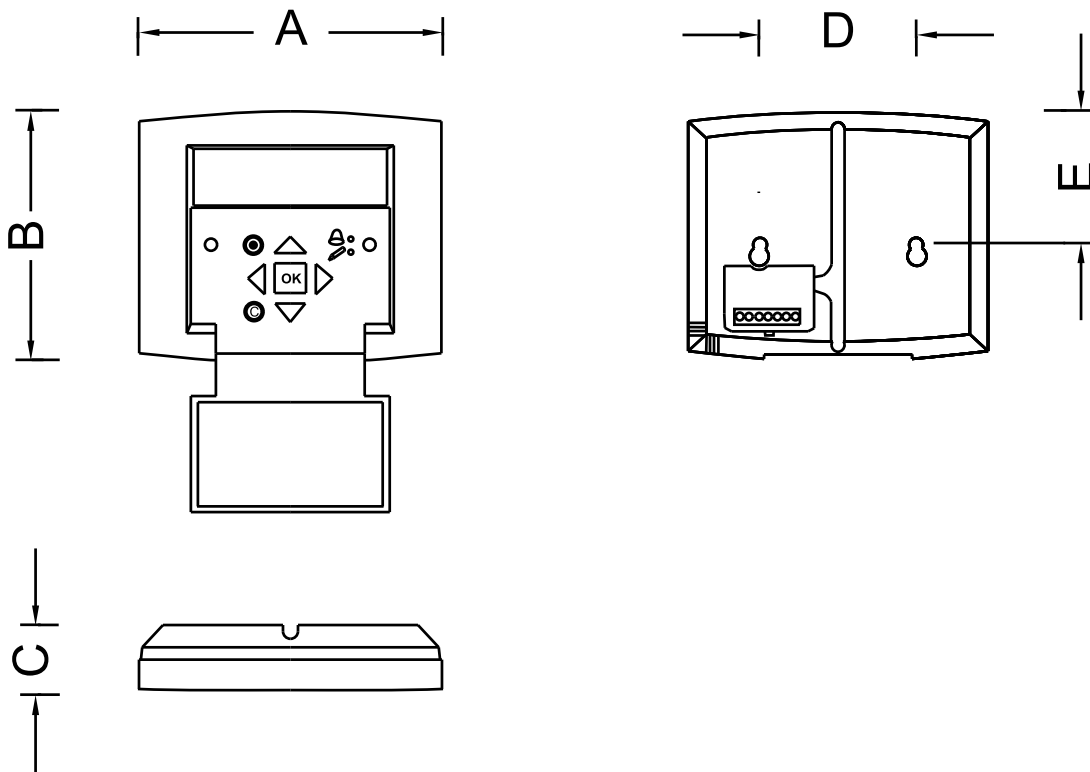

**Fig. 9 Control panel dimensions**

Position	Dimensions (mm)
A	115.0
B	94.0
C	26.0
D	c/c 60.0
E	50.5

## 6.3 Installation

1

Find an appropriate place to install the control panel. Maximum length between control panel and unit is 100 m.

2

If needed, drill two holes in the wall to hang the control panel (center to center: 60 mm) (pos.1, figure 10).

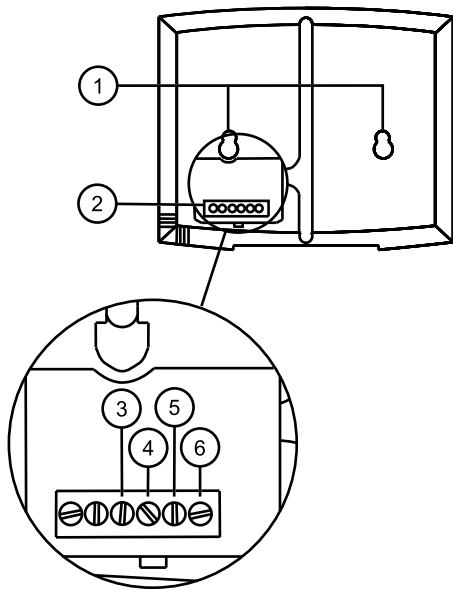

**Fig. 10 Control panel wire connections**

Position	Description
1	Mounting holes
2	Connection block
3	Connection to brown cable
4	Connection to yellow cable
5	Connection to white cable
6	Connection to black cable

## 7 Additional Equipment

For information concerning additional external equipment such as valve actuators, motorized dampers, E-tool, roof units, wall grilles etc. see technical catalogue and their enclosed instructions.

For electrical connections of external components see enclosed wiring chart.



Systemair Sverige AB reserves the right to make changes and improvements to the contents of this manual without prior notice.



Systemair Sverige AB  
Industrivägen 3  
SE-739 30 Skinnkatteberg, Sweden

Phone +46 222 440 00

Fax +46 222 440 99