

SYSLOOP

15 / 30

Water source heat pump

R410A

1.93 → 3.68kW

1.51 → 2.90kW

435 → 525 m³/h

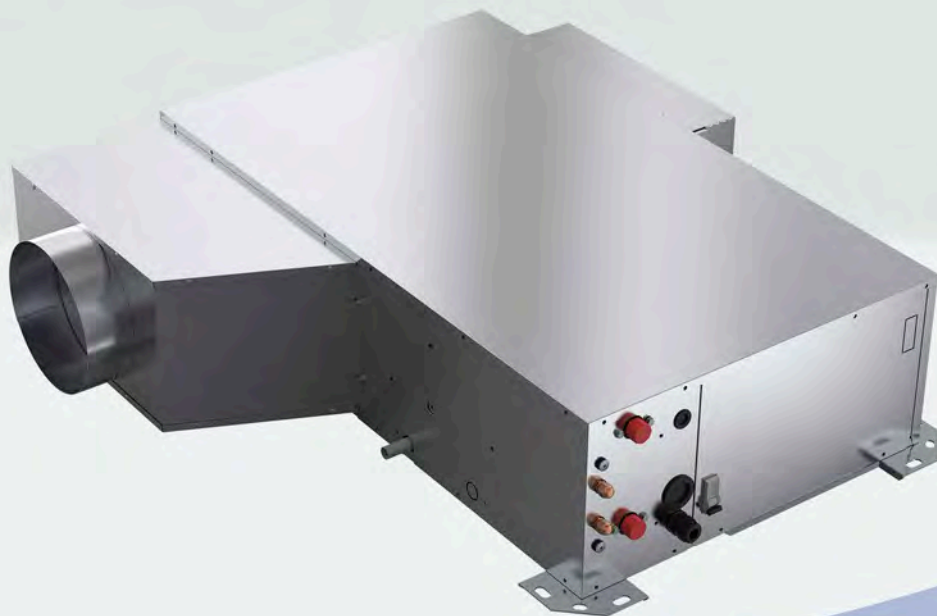
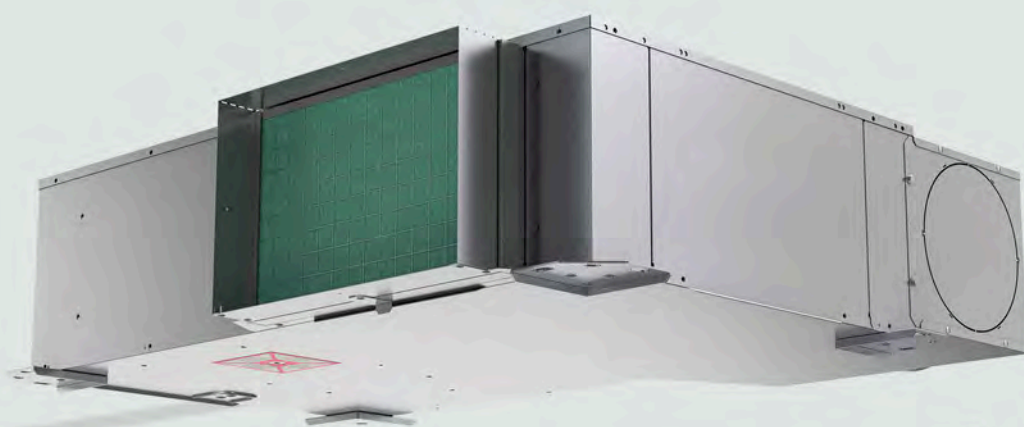

INSTALLATION INSTRUCTION

NOTICE D'INSTALLATION

INSTALLATIONSHANDBUCH

ISTRUZIONI INSTALLAZIONE

INSTRUCCIONES DE INSTALACIÓN

English

Français

Deutsch

Italiano

Español

CONTENTS

1. GENERAL RECOMMENDATIONS	3
1.1. SAFETY DIRECTIONS	3
1.2. WARNING	3
1.3. EQUIPMENT SAFETY DATA	4
2. INSPECTION AND STORAGE	5
3. WARRANTY	5
4. CONTENTS OF PACKAGE	5
5. DIMENSIONS	5
6. HANDLING	5
6.1. NET WEIGHT	5
7. REFRIGERATION SPECIFICATIONS	6
7.1. REFRIGERANT CIRCUIT DIAGRAM	6
7.2. REFRIGERANT CHARGE	6
7.3. FLUOROCARBON GAS REGULATIONS	6
7.3.1. CALCULATING GREENHOUSE GAS QUANTITIES	6
8. TECHNICAL SPECIFICATIONS	7
8.1. OPERATING LIMITS	7
8.1.1. ENVIRONMENT	7
8.1.2. TEMPERATURE LIMITS	7
8.1.3. FLOW LIMITS	7
9. ELECTRIC SPECIFICATIONS	8
9.1. ELECTRICAL POWER SUPPLY	8
10. INSTALLATION	8
10.1. GENERALITIES	8
10.2. CLEARANCE	9
10.3. UNIT LOCATION	9
11. DUCTING AND NOISE LEVEL REDUCTION	10
11.1. AIR BLOWING FRAME AND RETURN AIR INTAKE FRAME	11
11.2. AIR BLOWING PLENUM AND RETURN AIR INTAKE PLENUM	11
11.3. AIR DISCHARGE MODIFICATION	12
11.4. FILTER ACCESS	12
11.5. VENTILATION	12
11.6. AERAULIC ADJUSTEMENT	13
11.6.1. MODEL SL15	13
11.6.2. MODELS SL20 - SL30	14
12. UNCLAMPING THE COMPRESSOR	14
13. HYDRAULIC LINKS	15
13.1. WATER QUALITY	15
13.2. RECOMMENDATIONS FOR HYDRAULIC CONNECTIONS	16
13.3. RECOMMENDATIONS FOR CLEANING AND FLUSHING OUT THE SYSTEM	18
14. WIRING DIAGRAM AND LEGEND	19
14.1. WIRING DIAGRAM	19
14.2. LEGEND	19
14.2.1. POWER SUPPLY	19
14.2.2. PRESSOSTATS SETTING	19
15. ELECTRICAL CONNECTIONS	19
15.1. GENERALITIES	20
15.2. REMOTE CONTROL	20
15.2.1. WALL MOUNTING	20
15.2.2. ELECTRICAL CONNECTIONS	21
16. REGULATION	22
16.1. ORDER OF PRIORITY FOR CONTROL SYSTEMS	22
16.2. WALL-MOUNTED CONTROL	22
16.2.1. KEYPAD	22
16.2.2. SCREEN	23
16.2.3. TIME SETTINGS	23
16.2.4. SCHEDULING	24
17. FINAL TASKS	25
18. STARTING - RECOMMENDATIONS - SETTINGS	25
18.1. COMMISSIONING	26
18.1.1. DEMAND FOR COOLING	26
18.1.2. DEMAND FOR HEATING	26
19. MAINTENANCE AND SERVICING	27
19.1. FAULT FINDING	27
19.1.1. NEITHER THE FAN NOR THE COMPRESSOR OPERATE	27
19.1.2. VENTILATION (FAN) MODE OPERATES BUT THE COMPRESSOR DOES NOT OPERATE	27
19.1.3. INSUFFICIENT COOLING OR HEATING PRODUCTION	28
19.1.4. INSUFFICIENT WATER FLOW AT THE LEVEL OF THE COAXIAL EXCHANGER	28
19.1.5. APPEARANCE OF WATER DROPLETS IN THE APPLIANCE	28
19.1.6. APPEARANCE OF ABNORMAL NOISES AND VIBRATIONS IN THE CASING	28
19.2. ALARM CODES	29
20. IN CASE OF WARRANTY - MATERIAL RETURN PROCEDURE	29
21. ORDERING SERVICE AND SPARE PARTS ORDER	29



POWER SUPPLY MUST BE SWITCHED OFF BEFORE STARTING WORK IN THE ELECTRIC CONTROL BOX

1. GENERAL RECOMMENDATIONS

The purpose of this Manual is to provide users with instructions for installing, commissioning, using and maintaining the units. It also contains instructions on starting up the machine as well as recommendations to avoid bodily injury and risks of damage to the device during its operation.

It does not contain the complete description of all the maintenance operations guaranteeing the unit's long life and reliability. Only the services of a qualified technician can guarantee the unit's safe operation over a long service life.

Please read the following safety precautions very carefully before installing the unit.

1.1. SAFETY DIRECTIONS

Follow the safety rules in forces when you are working on your appliance.

The installation, commissioning, use and maintenance of these units should be performed by qualified personnel having a good knowledge of standards and local regulations, as well as experience of this type of equipment.

This appliance has not been designed for use by persons (including children) with reduced physical, sensorial or mental faculties or by persons without any experience or knowledge of heating systems, unless they act under the safety and supervision of a responsible person or have received prior training concerning the use of the appliance.

The unit should be handled using lifting and handling equipment appropriate to the unit's size and weight.

Any wiring produced on site must comply with the corresponding national electrical regulations.

Make sure that the power supply and its frequency are adapted to the required electric current of operation, taking into account specific conditions of the location and the current required for any other appliance connected to the same circuit.

The unit must be EARTHED to avoid any risks caused by insulation defects.

It is forbidden to start any work on the electrical components if water or high humidity is present on the installation site.

1.2. WARNING

Cutoff power supply before starting to work on the appliance.

When making the hydraulic connections, ensure that no impurities are introduced into the pipe work.

The manufacturer declines any responsibility and the warranty becomes void if these instructions are not respected.

If you meet a problem, please call the Technical Department of your geographical area.

If possible, assemble the compulsory or optional accessories before placing the appliance on its final location (see instructions provided with each accessory).

In order to become fully familiar with the appliance, we suggest to read also our Technical Instructions.

The information contained in these Instructions are subject to modification without advance notice.

1.3. EQUIPMENT SAFETY DATA

Safety Data	R410A
Toxicity	Low
In contact with skin	Skin contact with the rapidly evaporating liquid may cause tissue chilblains. In case of skin contact with the liquid, warm the frozen tissue with water and call a doctor. Remove contaminated clothing and footwear. Wash the clothing prior to re-use.
In contact with eyes	Vapours have no effect. Liquid splashes or sprays may cause freeze burns. In these cases rinse your eyes with running water or with a solution for eye lavages for at least 10 minutes. Immediately contact a doctor.
Ingestion	In this case, burns may result. Do not attempt to make the patient vomit. If the patient is conscious, rinse the mouth with water. Call a doctor immediately.
Inhalation	In case of inhalation, move the patient to an area with fresh air and provide oxygen if necessary. Perform artificial respiration if the patient has stopped breathing or lacks air. In case of cardiac arrest, perform external cardiac massage. Call a doctor immediately.
Further Medical Advice	Exposure to high concentrations can be dangerous for individuals with cardiac problems, as the presence of catecholamines such as adrenalin in the bloodstream may lead to increased arrhythmia and possible cardiac arrest.
Occupational exposure limits	R410A: Recommended limits: 1,000 ppm v/v 8 hours TWA.
Stability	Stable product
Conditions to avoid	Increased pressure due to high temperatures may cause the container to explode. Keep out of the sun and do not expose to a temperature >50°C.
Hazardous reactions	Possibility of dangerous reactions in case of fire due to the presence of F and/or Cl radicals.
General precautions	Avoid the inhalation of high concentrations of vapours. The concentration in the atmosphere shall be kept at the minimum value and anyway below the occupational limits. Since vapours are heavier than air and they tend to stagnate and to build up in closed areas, any opening for ventilation shall be made at the lowest level.
Breathing protection	In case of doubt about the actual concentration, wear breathing apparatus. It should be self-contained and approved by the bodies for safety protection.
Storage Preservation	Refrigerant containers shall be stored in a cool place, away from fire risk, direct sunlight and all heat sources, such as radiators. The maximum temperature shall never exceed 50°C in the storage place.
Protection clothes	Wear boots, safety gloves and glasses or masks for facial protection.
Behaviour in case of leaks or escapes	Never forget to wear protection clothes and breathing apparatus. Isolate the source of the leakage, provided that this operation may be performed in safety conditions. Any small quantity of refrigerant which may have escaped in its liquid state may evaporate provided that the room is well ventilated. In case of a large leakage, ventilate the room immediately. Stop the leakage with sand, earth or any suitable absorbing material. Prevent the liquid refrigerant from flowing into drains, sewers, foundations or absorbing wells since its vapours may create an asphyxiating atmosphere.
Disposal	The best procedure involves recovery and recycle. If this is not possible, the refrigerant shall be given to a plant which is well equipped to destroy and neutralise any acid and toxic by-product which may derive from its disposal.
Combustibility features	R410A: Non-inflammable at ambient temperatures and atmospheric pressures.
Containers	If they are exposed to the fire, they shall be constantly cooled down by water sprays. Containers may explode if they are overheated.
Behaviour in case of fire	In case of fire wear protection clothes and self-contained breathing apparatus.

2. INSPECTION AND STORAGE

At the time of receiving the equipment carefully cross check all the elements against the shipping documents in order to ensure that all the crates and boxes have been received. Inspect all the units for any visible or hidden damage.

In the event of shipping damage, write precise details of the damage on the shipper's delivery note and send immediately a registered letter to the shipper within 48 hours, clearly stating the damage caused. Forward a copy of this letter to the manufacturer or his representative.

Never store or transport the unit upside down. It must be stored indoors, completely protected from rain, snow etc. The unit must not be damaged by changes in the weather (high and low temperatures). Excessively high temperatures (above 60 °C) can harm certain plastic materials and cause permanent damage. Moreover, the performance of certain electrical or electronic components can be impaired.

3. WARRANTY

The appliances are delivered fully assembled, factory tested and ready to operate.

Any modification to the units without the manufacturer's prior approval, shall automatically render the warranty null and void.

The following conditions must be respected in order to maintain the validity of the warranty:

- Commissioning shall be performed by specialised technicians from technical services approved by the manufacturer.
- Maintenance shall be performed by technicians trained for this purpose.
- Only Original Equipment spare parts shall be used.
- All the operations listed in the present manual shall be performed within the required time limits.



THE WARRANTY SHALL BE NULL AND VOID IN THE EVENT OF NON-COMPLIANCE WITH ANY OF THE ABOVE CONDITIONS.

4. CONTENTS OF PACKAGE

Package contents:

- 1 appliance
- 1 suspension kit comprising:
 - 4 nuts
 - 4 locknuts
 - 4 shock mounts
 - 4 washers
- 1 installation manual

On opening the carton, check that all the accessories required for installation are present.

5. DIMENSIONS

SEE APPENDIX

6. HANDLING

The appliance may be handled with a pallet truck or a forklift truck.

6.1. NET WEIGHT



MODELS		SL15	SL20	SL30	
WEIGHT	WITH PLENUM	Kg	52	52	52
	WITHOUT PLENUM	Kg	47	47	47

7. REFRIGERATION SPECIFICATIONS

7.1. REFRIGERANT CIRCUIT DIAGRAM

SEE APPENDIX

7.2. REFRIGERANT CHARGE



Caution

This equipment contains fluorinated gas with greenhouse gas effects covered by the Kyoto agreement.

The type and quantity of refrigerating fluid per circuit are indicated on the product plate.

The installer and end user will get informed on local environmental regulations for the installation, operation and disposal of the equipment ; more particularly, for the collection of substances hazardous for the environment (refrigerating fluid, oil, antifreeze, etc.). A refrigerating fluid, whatever it is, must not be vented. Refrigerating fluids must be handled by skilled personnel.



Caution

SYSLOOP units use the R410A fluoro-carbonated fluid, belonging to group 2 as defined in directive 2014/68/UE. Considering the maximum operating pressure of these units (40 bar g), they integrate category 2 (or lower) components as defined in directive 2014/68/UE.

7.3. FLUOROCARBON GAS REGULATIONS

The EC No. 517/2014 regulation covering fluorinated greenhouse gases requires of refrigeration equipment operators to comply with the following five obligations:

1. Installation, servicing, maintenance as well as checking the sealing must be carried out by qualified personnel.
2. The fluorinated gas must be recovered during servicing and maintenance as well as the end of the installation.
3. All the necessary measures must be taken to prevent the leakage of fluorinated gases and any leaks must be repaired as rapidly as possible.
4. Regular checks on any leaks must be performed according to the following conditions:
 - ✓ for equipment containing fluorinated greenhouse gases in quantities greater than or equal to the equivalent of 5 tonnes of CO₂ but less than the equivalent of 50 tonnes of CO₂:
at least every twelve months or, if a leak detection system is installed, at least every twenty-four months
 - ✓ for equipment containing fluorinated greenhouse gases in quantities greater than or equal to the equivalent of 50 tonnes of CO₂ but less than the equivalent of 500 tonnes of CO₂:
at least every six months or, if a leak detection system is installed, at least every twelve months
 - ✓ for equipment containing fluorinated greenhouse gases in quantities greater than or equal to the equivalent of 500 tonnes of CO₂:
at least every three months or, if a leak detection system is installed, at least every six months.
5. A document grouping a description of all the operations carried out on the cooling circuit must be drafted and conserved.



Caution

Non-compliance with one of these obligations constitutes an offense and can result in financial penalties.

Furthermore, compliance of the equipment with the fluorinated gases regulation must be proven to the insurance company.

7.3.1. CALCULATING GREENHOUSE GAS QUANTITIES

$$\text{Greenhouse gas quantity (kg of CO}_2\text{)} = \text{Quantity of gas (kg)} \times \text{gas' GWP}$$

Quantity of greenhouse gas expressed in weight (kg) and CO₂ equivalent

GWP (Global Warming Potential) of the gas contained in the machine (see ID plate)

Quantity of gas: amount of gas contained in the machine in kg (see ID plate)

➤ **GWP for the R410A = 2088**

➤ **GWP for the R407C = 1774**

8. TECHNICAL SPECIFICATIONS

8.1. OPERATING LIMITS

8.1.1. ENVIRONMENT

This equipment is designed **EXCLUSIVELY** for **INDOOR** installation.

In general, sheltered locations such as garages, roof space, etc, do not provide sufficient protection against extreme temperatures and/or humidity and may be harmful to the unit's performance, reliability and service life.

8.1.2. TEMPERATURE LIMITS

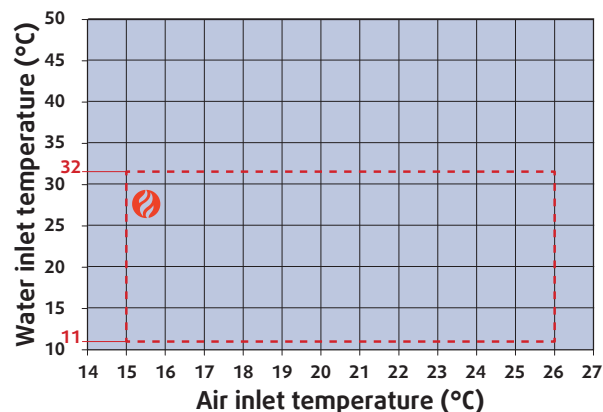
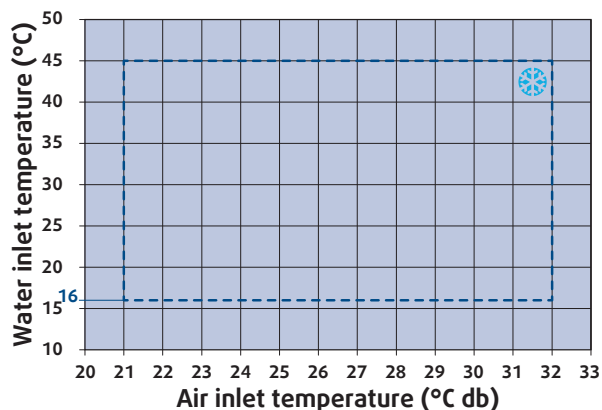

8.1.3. FLOW LIMITS

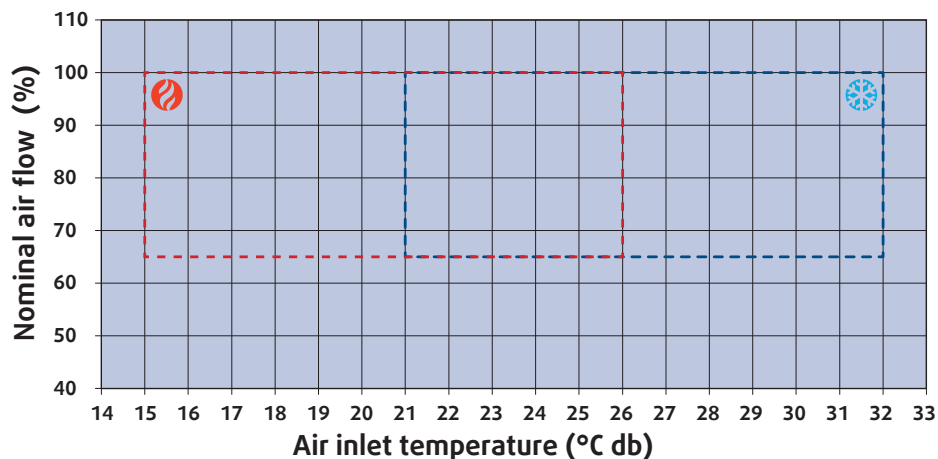

* Conditions in accordance with the standard: EN 14511-2

MODELS		SL15	SL20	SL30
Nominal air flow *	m ³ /h	435	465	525
65% Nominal air flow	m ³ /h	261	279	315

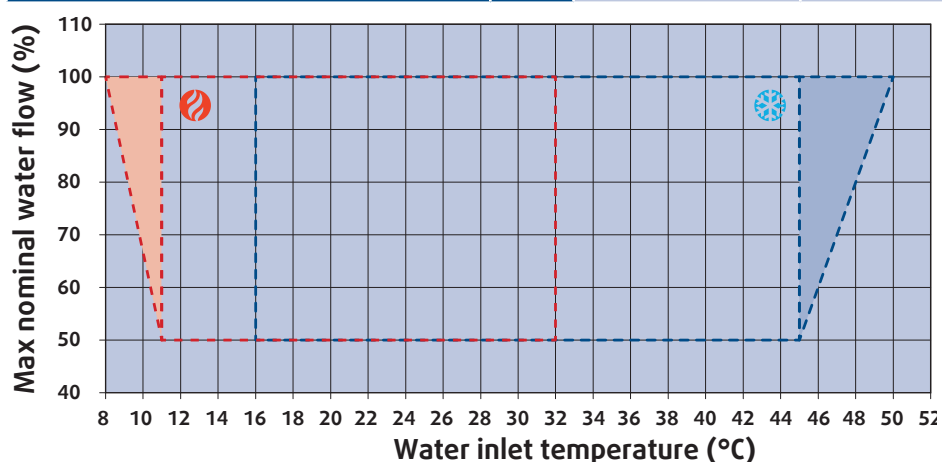

Caution

Operation within the shaded ranges requires special attention to the minimum water flow rate.

* Conditions in accordance with the standard: EN 14511-2

MODELS		SL15	SL20	SL30
Nominal water flow *	l/h	317	444	617
50% Nominal water flow	l/h	158.5	222	308.5
Maximum hydraulic pressure	bar	10	10	10

9. ELECTRIC SPECIFICATIONS

9.1. ELECTRICAL POWER SUPPLY

A variance of $\pm 10\%$ is acceptable in relation to the operating voltage marked on the appliance's Maker's Plate.

Operating voltages:

➤ 230V / 1 ph / 50 Hz (207 Volts minimum; 253 Volts maximum.)

Comments: the stated voltages represent the accepted range. However, certain components may be subject to premature wear on appliances operating continuously, for extensive periods, on abnormally low or high voltages.

MODELS		Fuse aM (without heating)	Full load current (max) (without heating)	Fuse aM (with heating)	Full load current (max) (with heating)	Starting amperage
230V	SL15	6A aM	4.8A	10A aM	8.7A	17.4A
	SL20	6A aM	5.5A	12A aM	10.8A	21.2A
	SL30	8A aM	6.93A	16A aM	12.9A	23.4A

10. INSTALLATION



Caution

The unit is not designed to withstand weights or stresses from adjacent equipment, pipe work or constructions. Any foreign weight or stress on the unit structure could lead to a malfunction or a collapse with dangerous consequences for personnel and property. In such an event, the warranty shall be null and void.

10.1. GENERALITIES

1. To avoid any damage, this equipment must not be used to supply heating or cooling during building work.
2. Check that the voltage, the number of phases and the capacity of the unit comply with the installation plans.
3. Check the size of the unit in relation to the plans to ensure that the unit will be installed in the right location.
4. After having removed the packing box, take out the suspension kit that is to be found inside the fan outlet frame.
5. Before installing the unit, check its height in relation to the available free ceiling height.
6. Take particular care over the location and routing of the water pipes and the condensate drainage pipe as well as the electrical wiring. The location and routing of these items must be clearly indicated on the plans.
7. It is always advisable for the heat pump installer to consult with all the various entrepreneurs responsible for the pipe work, partitioning, ceiling and electrical installation on the site.
8. If necessary, change the direction of the airflow inlet from the front to the side of the appliance, or vice versa, prior to installing the unit in the ceiling. Refer to the instructions detailed in § **AIR DISCHARGE MODIFICATION**, page 12.
9. We advise the installer to cover the appliances with a plastic sheet to protect it during the final building work.
This is particularly important if work such as spraying the joists with fire retardant, sanding, spray painting and plastering has not been completed.

10.2. CLEARANCE

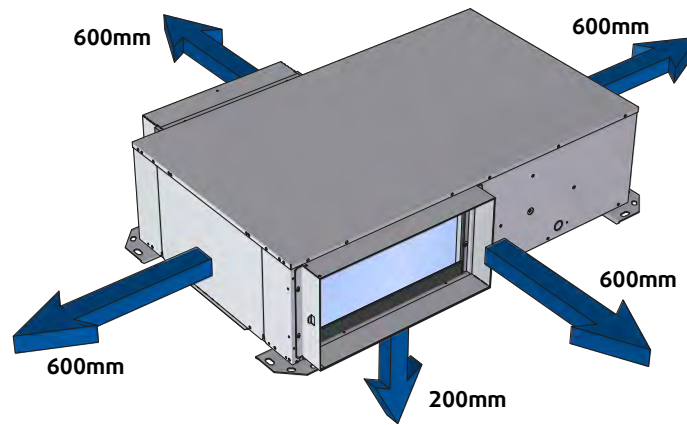

10.3. UNIT LOCATION



Caution

The unit base shall be arranged as indicated in the manual. There could be a risk of personal injury or damage to property in the event of the unit being incorrectly supported.

1. Install the unit in a location allowing easy removal of the filter and the access panels to the electrical box/ compressor and fan by leaving sufficient free space for servicing personnel to perform maintenance and repairs. Leave sufficient space for the water, electricity and duct connections.

2. The installer must ensure that access under the suspended ceiling is provided, and that sufficient space is provided for the suspension angle brackets, the duct attachment collars and the water and electrical connections.
3. Provide space under the unit for a siphon on the condensates drainage pipe. Do not install the unit on top of pipe work.
4. Each unit is suspended from the ceiling on four threaded rods. The rods are attached through the shock mounts to the corners of the unit by suspension angle brackets. **Warning!** Do not use rods of a diameter smaller than that stated below. The rods must be solidly anchored to the ceiling and to the ceiling joists.

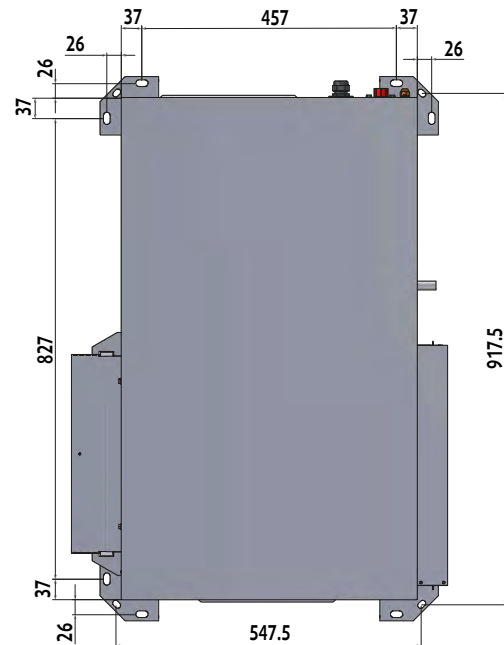

5. Each unit is supplied with a set of pre-fitted suspension angle brackets and a fitting kit contained in the pouch with the technical manual. The kit comprises 4 shock mounts, 4 washers, 4 nuts and 4 locknuts.
6. Arrange the threaded rods in accordance with the dimensions stated below. The use of nuts and locknuts is recommended for attaching the suspension rods to the unit as the unit's vibrations may loosen a single nut. The installer is liable for any damage in the event of this recommendation not being followed.
7. To facilitate drainage, the unit must be angled in both planes towards the condensates drainage pipe. (Slope minimum: 2 %)

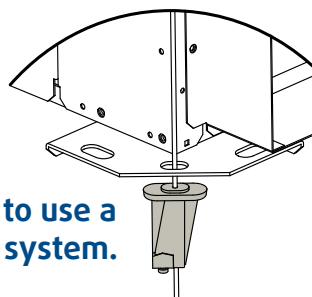

It is also possible to use a cable suspension system.

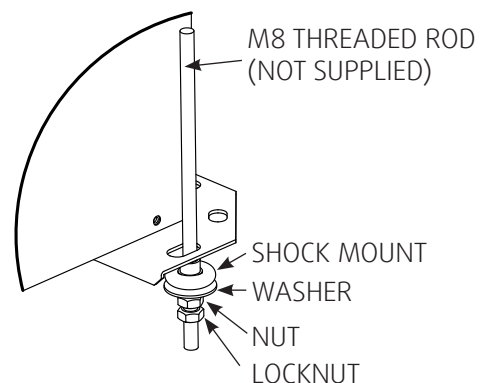

11. DUCTING AND NOISE LEVEL REDUCTION

Water circuit heat pumps are usually installed in conjunction with an air blowing duct. A return air duct may also be required. All ductwork shall be compliant with best air conditioning engineering practices.

The air blowing duct system normally consists of a flexible connector mounted on the unit, a bridging section to link to the size of the main duct, a short section of straight duct, an elbow without a damper and a main duct with spurs equipped with distribution grilles as illustrated in the drawing below. The sum total of the bridging section angles must not be higher than 30°, otherwise there will be significant performance losses.

Do not connect the main duct directly to the unit without a bridging section to reduce the duct size to that of the unit's connection collar. In the event of using metal ducts, only the sides of the elbow section and all the spur duct sections should be covered with fibreglass sound insulation for reducing the noise level. Fibreglass duct panels are more sound absorbent and may enable the flexible canvas connection to be eliminated.

The duct network must be laid out to avoid any rectilinear runs between the heat pump outlet and the air distribution outlets.

The return air intake ducts can be connected to a grille/filter located at the base of a wall, then directed via hollow partitions towards a ceiling mounted plenum or via ceiling mounted grilles. The ceiling grilles must not be located directly below the air conditioning unit.

The return air intake duct can be connected directly to the standard filter bracket. (Lateral filter removal advisable).

Do not drill panel screws directly into the unit's casing for connecting the blowing and return air intake ducts, especially on the air return side, as there is a risk of damaging the condensate recovery tray and the battery.

Recommended layout diagram for installation with several air distribution outlets

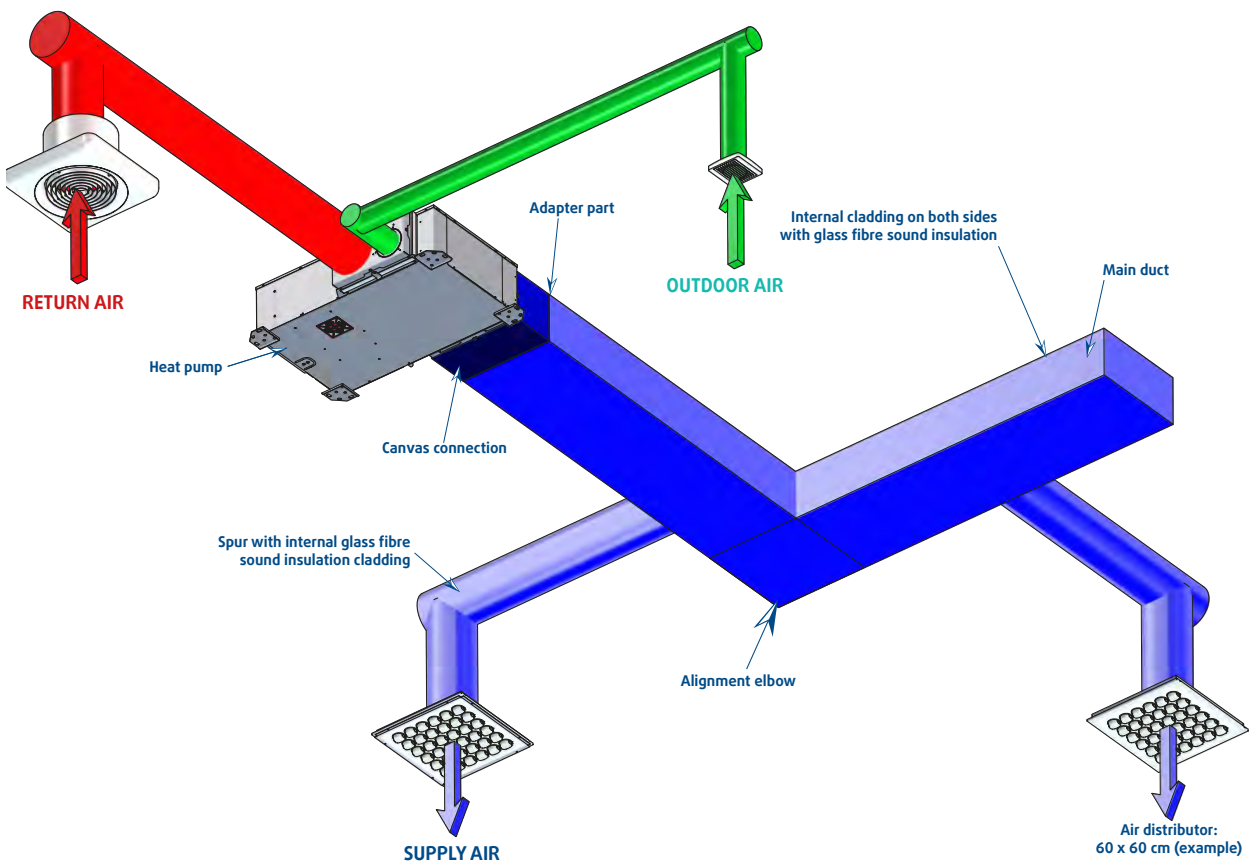

11.1. AIR BLOWING FRAME AND RETURN AIR INTAKE FRAME

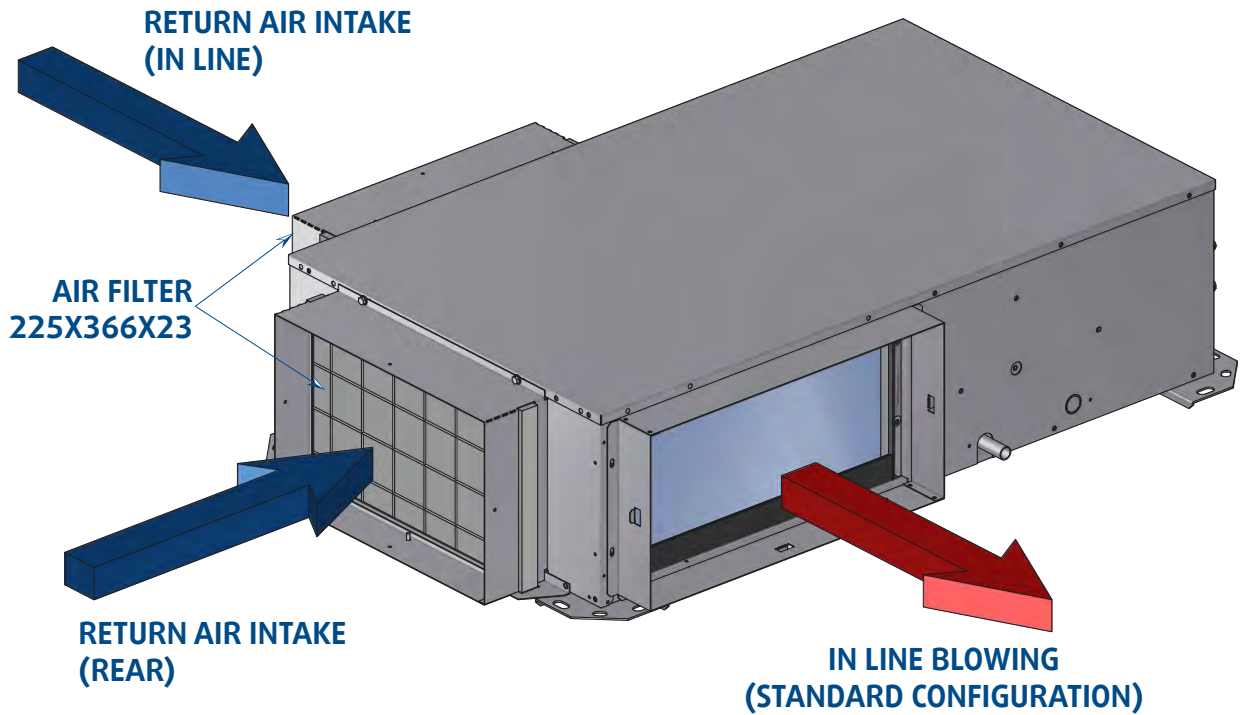

11.2. AIR BLOWING PLENUM AND RETURN AIR INTAKE PLENUM

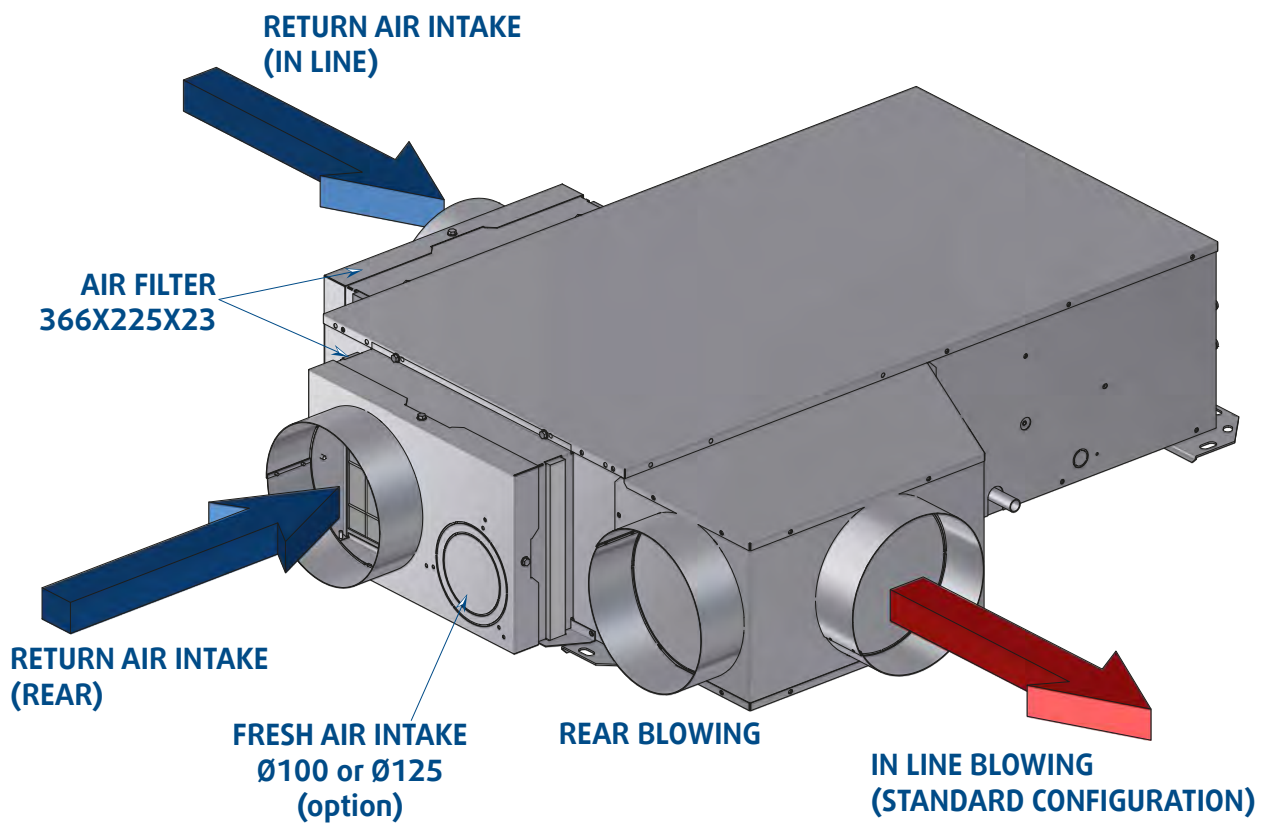

11.3. AIR DISCHARGE MODIFICATION

The units can be delivered configured either for frontal air return, known as "In LINE" or for side air return. It is also possible to modify the return air configuration onsite by proceeding as follows:

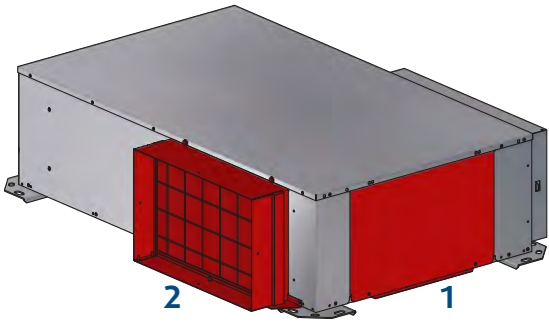

1. Remove the access panel 1.
2. Remove the air return panel 2.

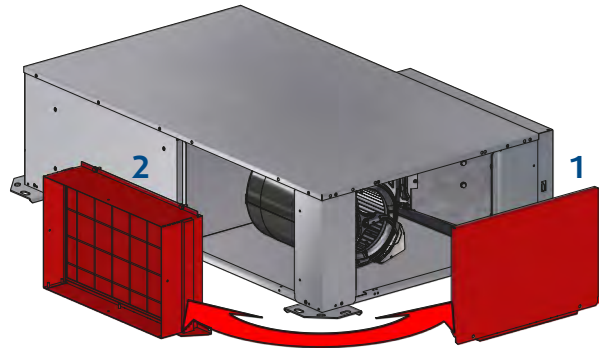

3. Fit the return air panel 2 in the location previously occupied by the access panel 1.
4. Refit the access panel 1.

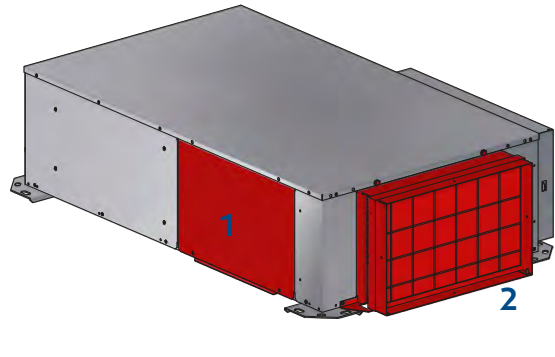
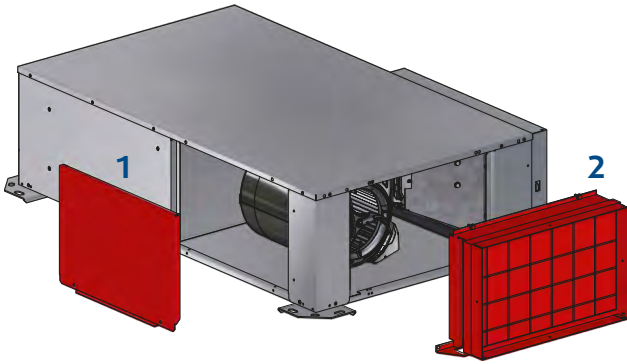

11.4. FILTER ACCESS

The filter can be removed either from the side 1 or from the top 2 without having to dismantle the connection duct.

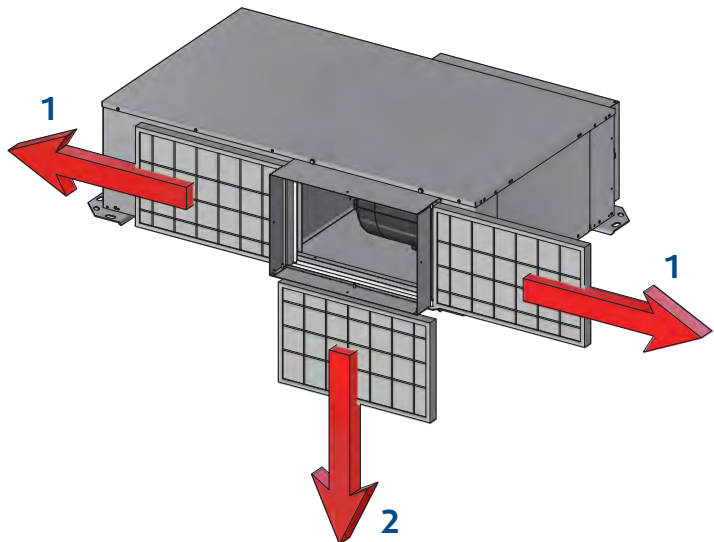
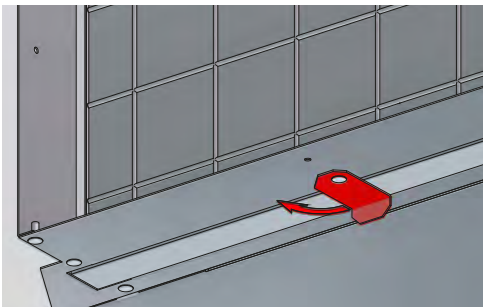

11.5. VENTILATION

An outdoor air intake (new air) may be required for ventilation. The blown air temperature must be controlled in order to avoid the temperature of the mixture of outdoor air and return air at the heat pump inlet exceeding the appliance's operating limits. It is also common practice to shut down ventilation during periods of inoccupation (night time setting of the set temperature).

Each appliance's ventilation system is generally a sub-system within the building, with its own distribution duct network. The simple introduction of outdoor air into each return air plenum, quite close to the unit's return air intake is sufficient and recommended. New air should not be introduced directly into the appliance. Provide for a sufficient distance to ensure effective mixing of the outdoor air with the return air. (Refer to the § **OPERATING LIMITS**, page 7).

11.6. AERAUIC ADJUSTEMENT

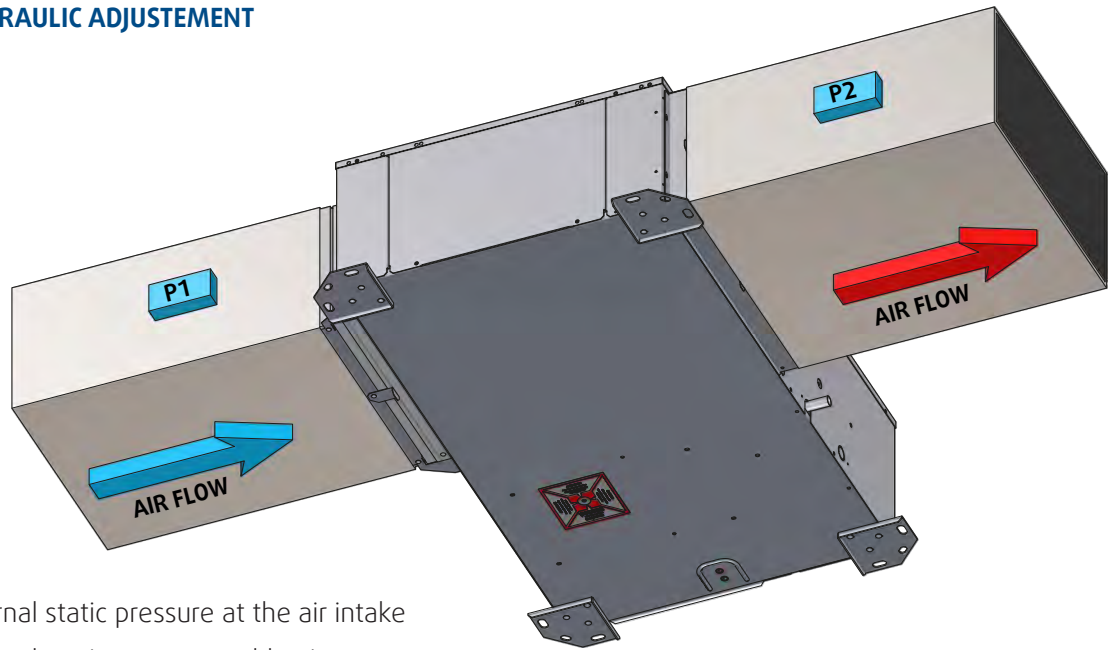

P1 : External static pressure at the air intake

P2 : External static pressure at blowing

EXTERNAL STATIC PRESSURE = P2-P1



Caution

External static pressure at the air intake above -100Pa

External static pressure at blowing less than 100Pa

11.6.1. MODEL SL15

BASIC FILTER - WITHOUT PLENUN

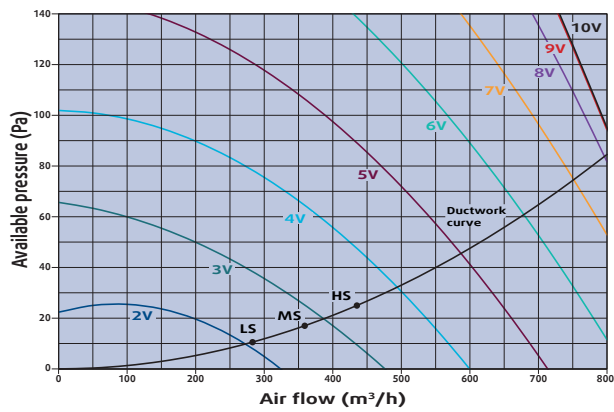

BASIC FILTER - WITH PLENUN

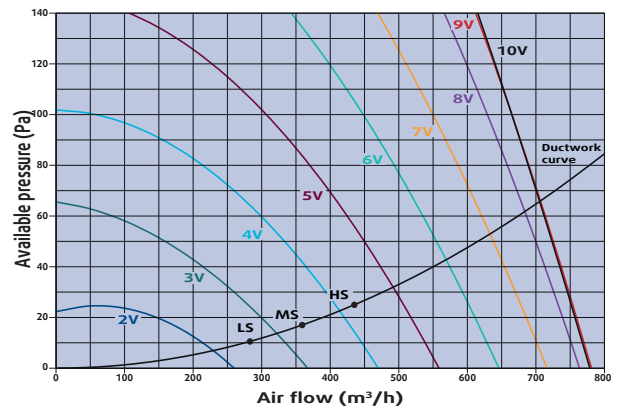

G3 FILTER - WITHOUT PLENUN

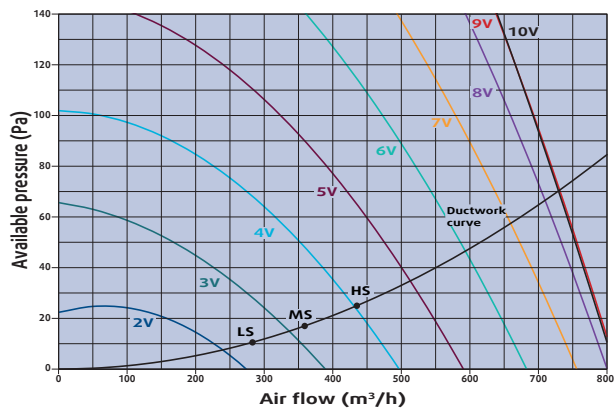

G3 FILTER - WITH PLENUN

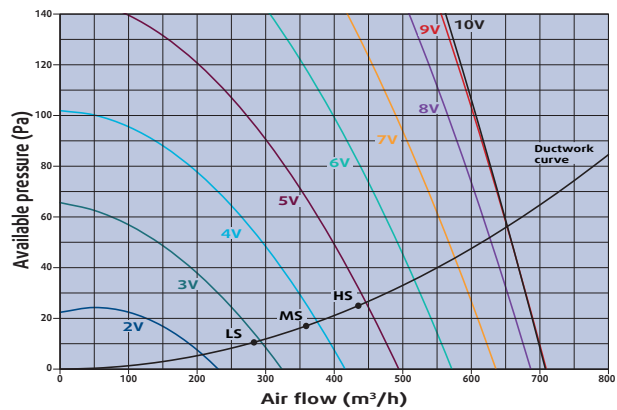

LS : low speed

MS : medium speed

HS : high speed

11.6.2. MODELS SL20 - SL30
BASIC FILTER - WITHOUT PLENUM

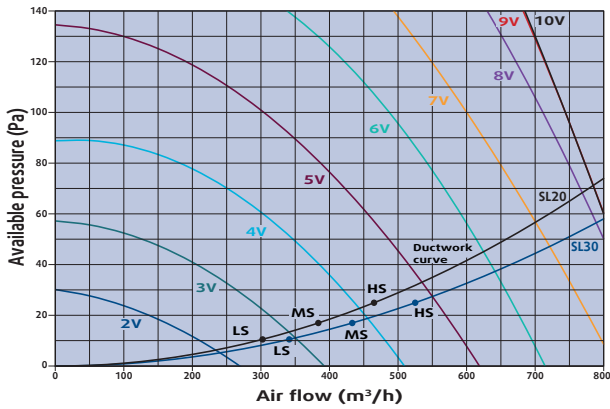

BASIC FILTER - WITH PLENUM

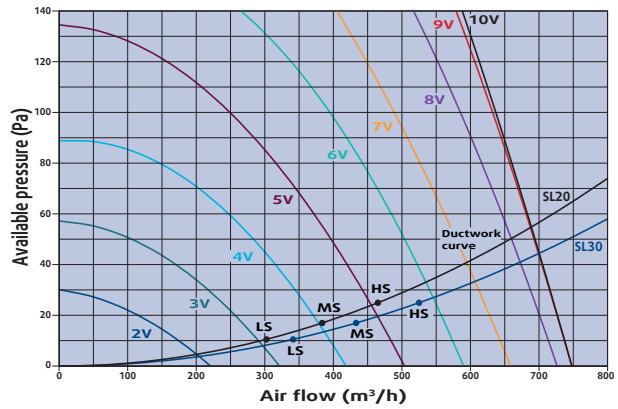

G3 FILTER - WITHOUT PLENUM

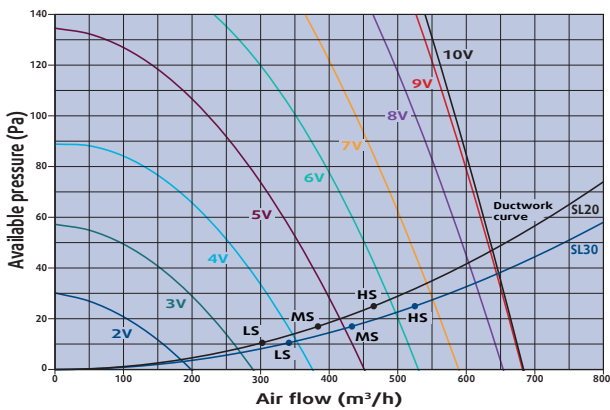

G3 FILTER - WITH PLENUM

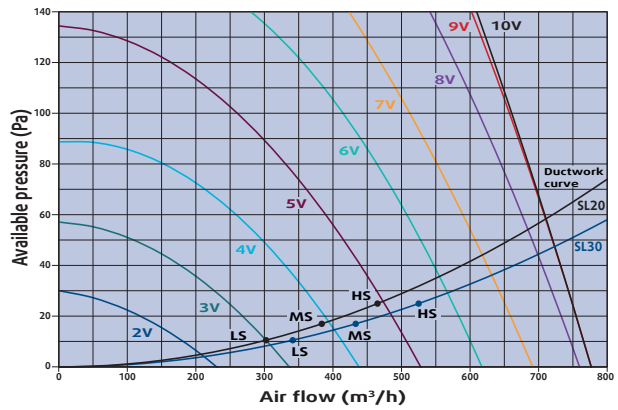

LS : low speed

HS : high speed

MS : medium speed

12. UNCLAMPING THE COMPRESSOR



Caution

Before the first start-up the compressor transport clamping be removed. Failure to do this could result in vibrations, high noise and could lead to the refrigerant tubes breaking.

It is not necessary to open the panels to unlock the compressor. This can be achieved by removing the locking screws accessible on the underside.

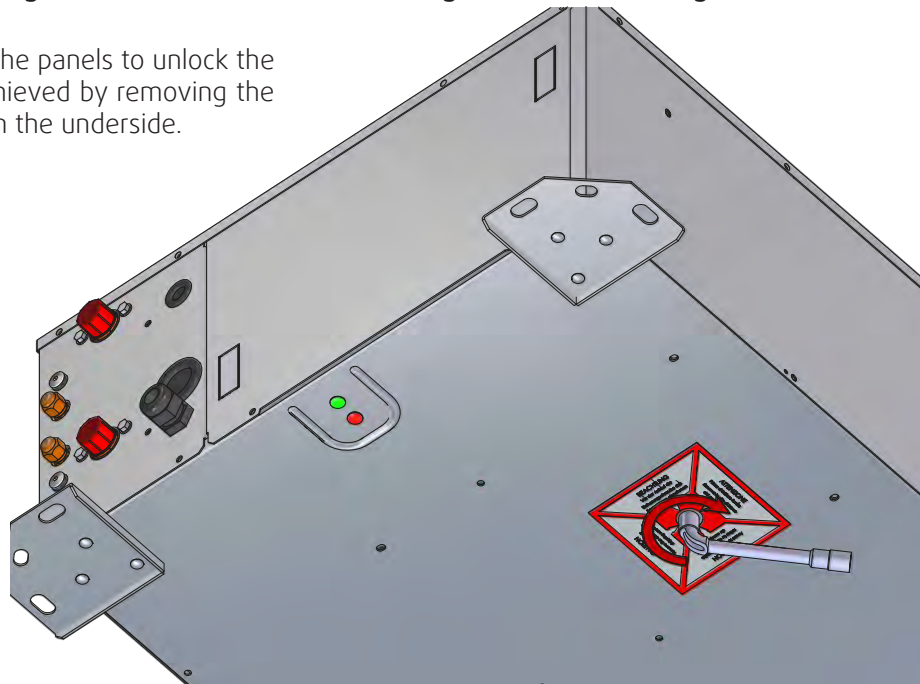

13. HYDRAULIC LINKS



Caution

THE WARRANTY DOES NOT COVER DAMAGE DUE TO CORROSION RESULTING FROM ELECTROLYTIC PHENOMENA.

13.1. WATER QUALITY

The water must be analyzed; the hydraulic network system installed must include all elements necessary for water treatment: filters, additives, intermediate exchangers, drain valves, vents, check valves, etc., according to the results of the analysis.



Caution

The SYSLOOP must not run on a network with open loops, likely to cause incidents related to oxygenation, or with non treated table water.

Using improperly treated or non treated water in the **SYSLOOP** may cause scaling, erosion, corrosion or algae or sludge deposits in the exchangers. Refer to a specialist skilled in water treatment to determine any treatment to apply. The manufacturer will not be held liable for damages caused when non treated or improperly treated water, demineralized water, salty water or sea water are used.

Apply the following guidelines :

- No NH_4^+ ammonium ions in the water, highly detrimental to copper. <10mg/l
- Cl⁻ chloride ions are detrimental to copper with a risk of puncture by picking corrosion. <10mg/l.
- SO_4^{2-} sulphate ions may cause perforating corrosion. < 30mg/l.
- No fluoride ions (<0.1 mg/l)
- No Fe^{2+} and Fe^{3+} ions, particularly in case of dissolved oxygen. Fe < 5mg/l with dissolved oxygen < 5mg/l. The presence of these ions with dissolved oxygen indicates corrosion of steel parts, likely to generate corrosion of copper parts under Fe deposits, particularly in the case of multitubular exchangers.
- Dissolved silica: silica is an acid element of water and may also cause corrosion. Content < 1mg/l.
- Water hardness: Values between 10°FH and 30°FH may be recommended. This facilitates scaling deposits likely to limit copper corrosion. Excess TH values may lead to clogging the pipes.
- TAC < 100
- Dissolved oxygen: Prevent any sudden change in the water's oxygenation conditions. Also, avoid deoxygenating water by sparging inert gas as well as overoxygenating it by pure oxygen sparging. Disturbing oxygenation conditions destabilizes copper hydroxides and particle salting-out.
- Electrical Resistivity - Conductivity: The higher the resistivity, the slower the corrosion. Values above 3000 ohm/cm are preferred. A neutral environment favours maximum resistivity. For electrical conductivity, values around 200-600 S/cm can be recommended.
- pH: neutral pH at 20°C (7 < pH < 9)



Caution

If the water circuit is to be drained for a time exceeding one month, the circuit must be fully charged with nitrogen to prevent any risk of corrosion by differential venting.



Caution

The manufacturer is not liable for recommendations in terms of water treatment (call a specialized company).

However, this matter has a critical nature, and particular care must be given to ensure that the type of treatment applied is effective.

The liability of the manufacturer or its representative will not be sought when non treated water or non compliant quality water is used.

13.2. RECOMMENDATIONS FOR HYDRAULIC CONNECTIONS

1. It is recommended that all units are connected to a water supply and return pipe system of the Tickelman Loop type. The Tickelman Loop system is self-balancing and thus only requires manual balancing if a large number of units with different flow and pressure loss characteristics are connected to a single hydraulic loop. A very simple way of checking the hydraulic balance is to measure the temperature difference between the water connections. To ensure a correct water flow, the difference must be in the region of 3 to 7 °C in Cooling mode and 2 to 5°C in Heating mode.

A system with two parallel pipes can also operate in a perfectly adequate manner, but it is more difficult to achieve, and to maintain, balance.



2. **Never connect a unit to the water supply and return lines without completely cleaning and flushing out the hydraulic loop beforehand.** After performing these operations, the units must be connected, with all valves completely open, ready for the system to be filled with water.
3. Water exchanger clogging reduces efficient appliance operation. We recommend the installation of a **strainer filter** (Ø 0.8mm) on the appliance's water inlet pipe. The filter must be installed if the water circuit cannot be cleaned. This filter should be installed between two cut-off valves and it must remain easily accessible for the user so that it can be checked at regular intervals.
4. Steel, copper or P.V.C. pressure pipes may be used.
5. It is advisable to make the unit's water supply and return conveyance lines with short lengths of high-pressure hose, as they form excellent shock absorbers for unit operating noise and hydraulic pressure surges.

One of the hose ends must be fitted with a rotating connector to facilitate removal for maintenance. Rigid pipes can be connected directly to the unit, but this is not recommended due to their inability to absorb vibrations and noise.

Rigid pipes must be equipped with removable connectors to facilitate future removal of the unit from its location.

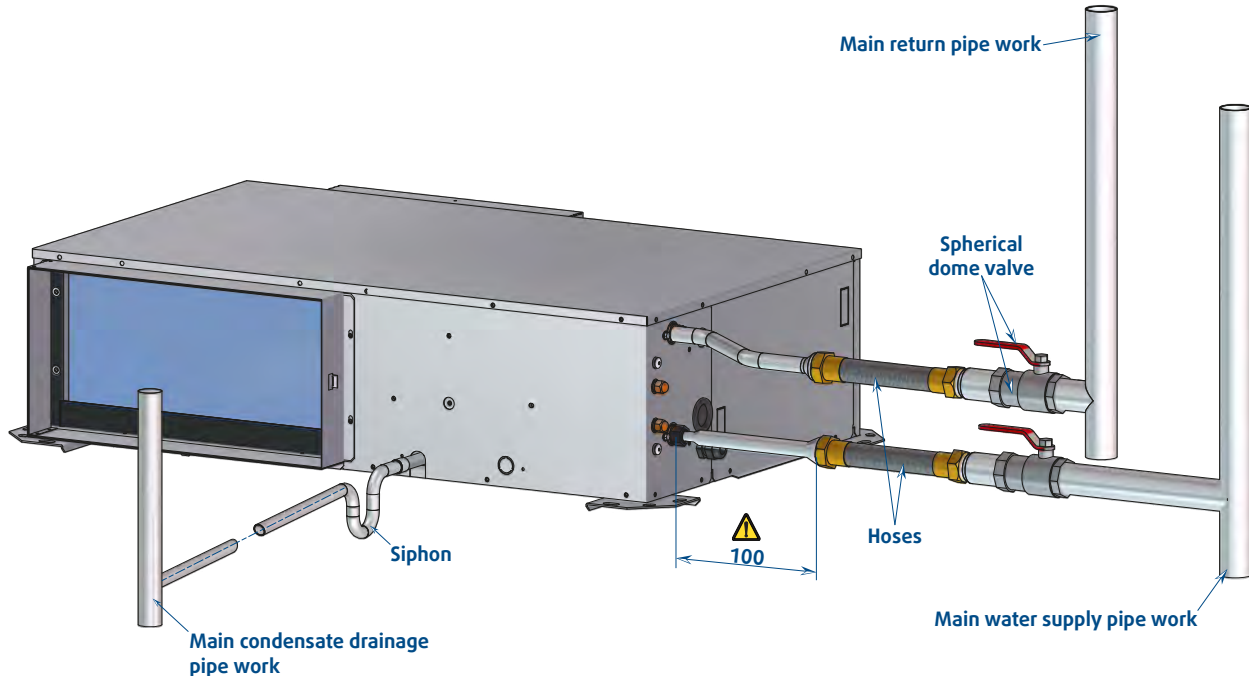

6. Certain flexible hose threaded connectors are supplied with sealing paste. If this is not the case, use Teflon tape to create a tight seal.
7. Each unit must be equipped with isolation valves on the water inlet and outlet pipes. The return isolation valve is used for both cutting off the water supply and balancing the installation's water flow. As it is used to establish the balance of the flows, **it must be equipped with a lockable position end stop**. This end stop ensures that, after the valve is closed, it can only be re-opened as far as the position required to maintain a balanced water flow.
8. Use steel, copper or P.V.C. pipes for the condensates drainage pipe. Each unit is supplied with a connector for condensates drainage.
9. The condensates drainage line must comprise a siphon and run from the unit on a downward slope of at least 2%. Generally, the siphon is connected directly to the unit's condensates drainage outlet. A length of plastic pipe can be used between the siphon and the condensates drainage line.

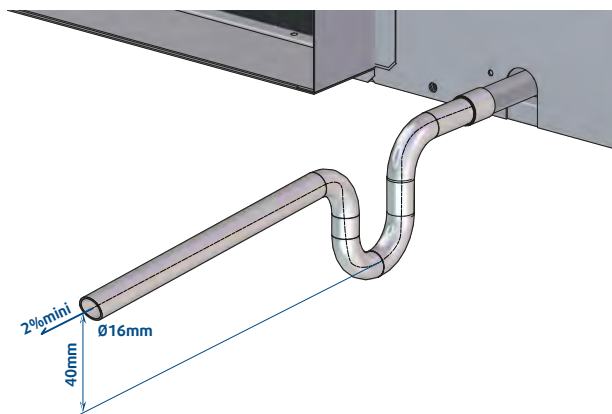

**Coil at the unit blowing
(standard)**

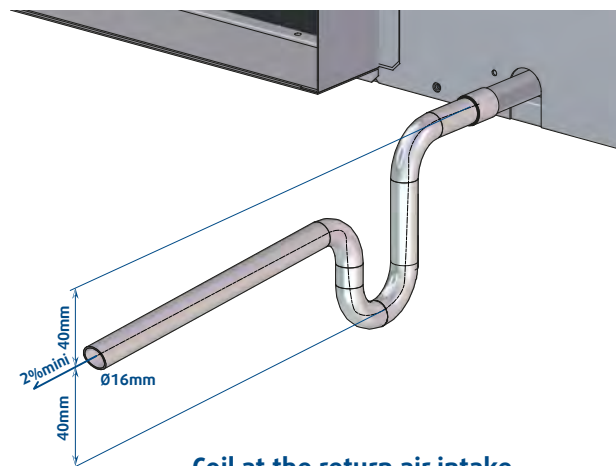

**Coil at the return air intake
(on request)**

A complete condensates drainage system with copper or P.V.C. pipe can also be used. Screw-on connectors shall be fitted to facilitate drainage pipe removal if copper pipe is used for the drainage pipe work.

10. No point of the condensates drainage pipe work should be located above the level of one of the units' condensate drainage outlet connection.
11. The circuits' high points must be bled of air.
12. Comply with current regulations in terms of dielectric isolation of the connectors and the pipe work.

13.3. RECOMMENDATIONS FOR CLEANING AND FLUSHING OUT THE SYSTEM

1. Before commissioning an appliance for the first time, the water loop must be cleaned and rinsed out to remove any dirt and manufacturing debris.

If the appliances are equipped with isolation valves (either electric or pressostatic), the water supply and return conveyance circuits to and from each machine must be connected to each other. This will avoid any dirt being introduced into the units.

Flushing water through the units is acceptable if they are not equipped with water flow control devices.

2. The system must be filled from the mains water supply. All air bleeds must be open during filling. Close the air bleeds once the system is filled. The installer must start the main circulation pump with the water top-up tap on the pressure reduction valve in the open position. Check the air bleeds by increasing order of height to ensure water flows freely throughout the entire system.

Power supply to the cooling tower must be shut down, and the water loop temperature regulation thermostat must be set at 27 °C.

As the water circulates through the system, the installer must seek out and repair any possible pipe work leaks.

The drain cocks, on the lowest points on the circuit, must be open for flushing out and chasing out any impurities. Ensure that the mains water valves are adjusted to allow water to enter at the same speed as it exits. Check the pump inlet pressure gauge and manually adjust the compensating valve to maintain the same pressure before and after the opening of the drain taps. Flushing must be performed for at least two hours, or longer if necessary, until clear and clean water is obtained at the drain taps.

3. Stop the additional heating and the water circulation pump. Open all the bleed points and the drain taps to empty the system completely. The short-circuited water supplies and returns must now be connected to the units' inlet and outlet connections. It is recommended to use Teflon tape on the pipe connector threads. Do not use sealing paste on the hoses' rotating connectors.

4. **Formerly, sodium tri-phosphate used to be recommended as a cleaning agent for flushing.**

However, nowadays numerous countries forbid the introduction of phosphates into their wastewater networks. **Therefore, it is now recommended that the system is flushed out with hot water (30 °C).**

5. Fill the system again with clean water. Test the water acidity level (litmus paper), and treat as required to obtain a slightly alkaline water quality.

At this stage, the recommended percentage of anti-freeze can be added. Use commercial quality anti-freeze specifically intended for air conditioning systems. Do not use automobile radiator anti-freeze.

6. On the main electrical cabinet, adjust the heater set temperature point at 20 °C and the cooling tower set temperature at 30 °C. Connect the power supply to all motors and start the circulation pumps.

When the normal flow level has been reached through all components, including the cooler (irrespective of the season) and when the air is bled from the system and the loop temperature has stabilised, each appliance is ready to be checked, tested and started for balancing the air and water flows.

INTERCONNECTED CONVEYANCES

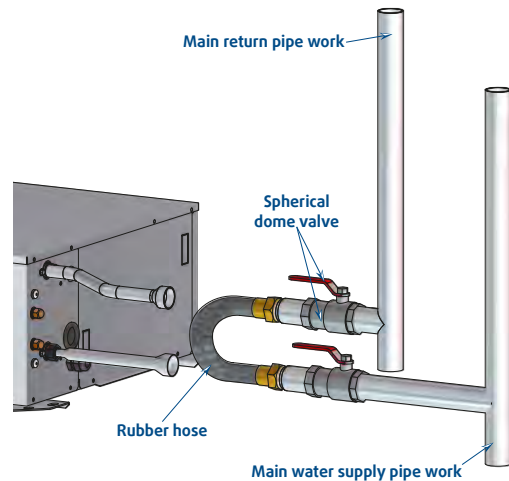

14. WIRING DIAGRAM AND LEGEND

14.1. WIRING DIAGRAM

SEE APPENDIX

SE4760	models SL15/SL20/SL30	EC motor	Control Siemens	230V 50Hz +/- 10%
SE4779	models SL15/SL20/SL30	EC motor	Control Storm 2	230V 50Hz +/- 10%

14.2. LEGEND

N 823

SEE APPENDIX

14.2.1. POWER SUPPLY

The power supply must be protected by an FFG mains circuit breaker.

All the electrical installations and wiring associated with this equipment must comply with local installations regulations.

Connection to the terminals N, L and \perp .

- L : phase
- N : neutral
- \perp : P-E ground

14.2.2. PRESSOSTATS SETTING

LP : Low Pressure fixed setting: 3.4 bar (49 PSI) reset at 5.0 bar (72 PSI)

HP : High Pressure fixed setting: 40 bar (580 PSI) reset at 33 bar (479 PSI).

15. ELECTRICAL CONNECTIONS

WARNING



Before carrying out any work on the equipment, make sure that the electrical power supply is disconnected and that there is no possibility of the unit being started inadvertently.

Non-compliance with the above instructions can lead to injury or death by electrocution.

The electrical installation must be performed by a fully qualified electrician, and in accordance with local electrical standards and the wiring diagram corresponding to the unit model.

Any modification performed without our prior authorisation may result in the unit's warranty being declared null and void.

The power supply cable section must be sufficient to provide the appropriate voltage to the unit's power supply terminals, both at start-up and under full load operating conditions.

The power supply cable shall be selected in accordance with the following criteria:

1. Power supply cable length.
2. Maximum unit starting current draw – the cables shall supply the appropriate voltage to the unit terminals for starting.
3. Power supply cables' installation mode.
4. Cables' capacity to transport the total system current draw.

Short circuit protection shall be provided. This protection shall comprise fuses or circuit breakers with high breaking capacity, mounted on the distribution board.

If the local control includes an remote ambient temperature sensor and/or a set temperature adjustment module, these shall be connected with shielded cable and shall not pass through the same conduits as the power supply cables as the voltages induced may create reliability faults in the unit's operation.

15.1. GENERALITIES

Ensure that the available electrical power supply and the network frequency are matched to the required operating current, taking account of the appliance's specific location and the current required to supply any other appliances connected to the same circuit.

1. Ensure that the unit is supplied with the specified voltage. One stuffing box and two grommet holes are provided on the side of the appliance. They are used respectively for the power and the control wiring. The power supply line must be properly dimensioned with a motor supply type fuse or a mains circuit breaker to protect the circuit against voltage surges. (Refer to the Maker's Plate for the voltages to be taken into consideration).
2. Always shut down the power supply to the unit before connecting the thermostat wiring.

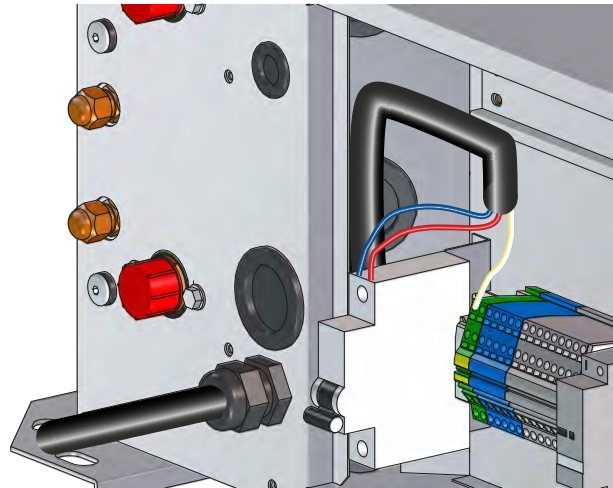
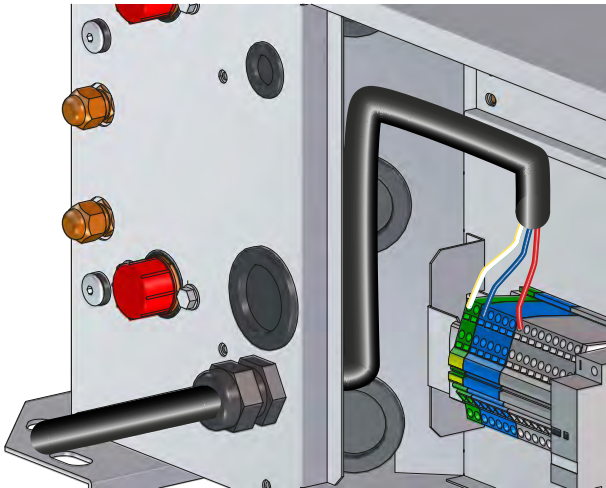

15.2. REMOTE CONTROL

15.2.1. WALL MOUNTING

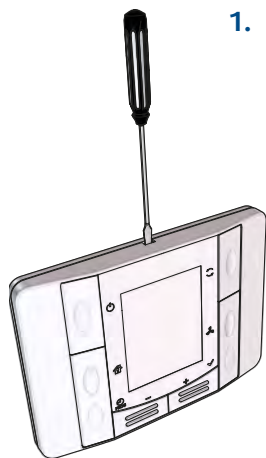

1. Separate the remote control from its rear plate.

Checking the support bracket :

Ensure that the wall surface is completely flat at the point where you wish to install the remote control, as it is important that the remote control is not twisted on installation, because any bending could lead to the control not clipping together properly and result in operating difficulties.

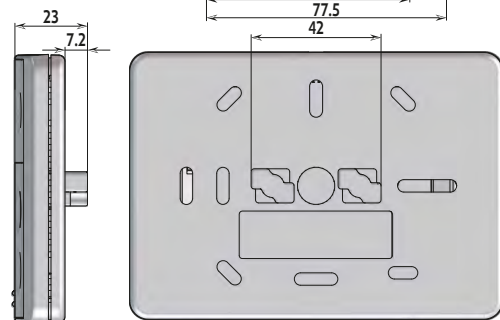
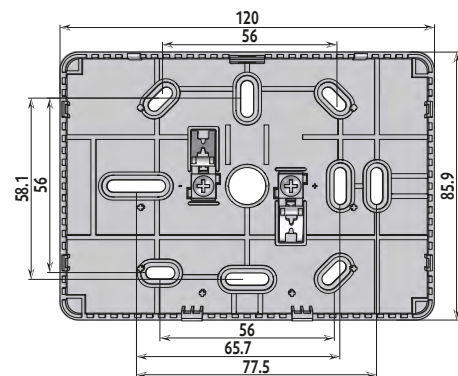
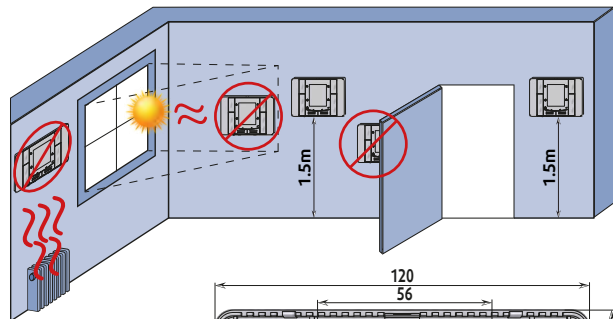

2. Fitting the rear plate :

- Present the rear plate to the desired location and align it with a spirit level.
- Mark the screw locations.
- Make a hole or install appropriate plugs according to the material (wood, concrete, plasterboard etc.).
- Screw the rear plate to the wall.

3. Wire the remote control in accordance with the wiring diagram.

4. Clip the remote control onto the rear plate.

15.2.2. ELECTRICAL CONNECTIONS

The control return must be connected as per the following diagrams.

For the connection, use a KNX TP1 type cable (Twisted pair with insulation) with a 0.8mm² cross-section.

SYSLOOP - AUTONOMOUS

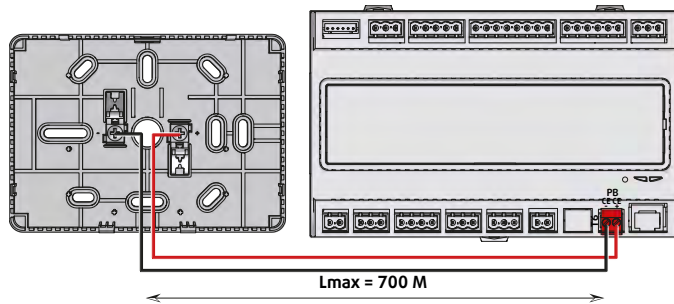

SYSLOOP - MASTER/SLAVES

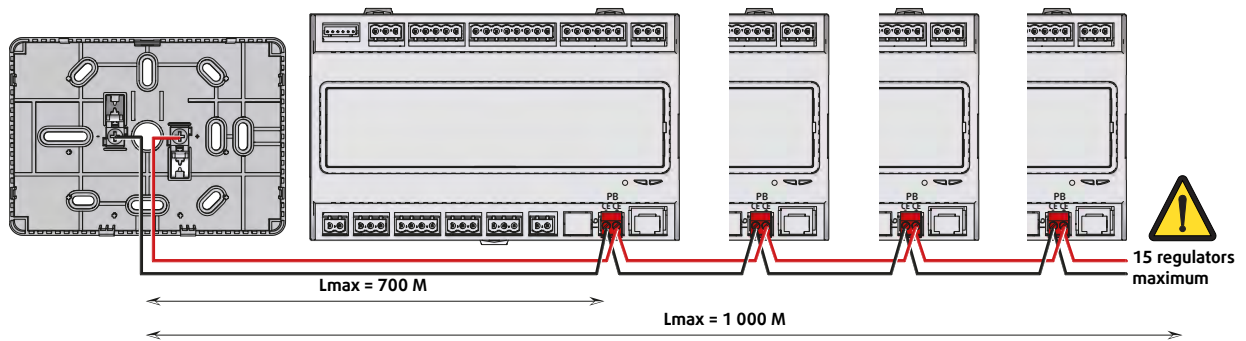

Caution

Master/slaves operation requires the allocation of a specific address to each controller. This addressing occurs by connecting a POL871 or POL895 display to the "BSP-BUS" port of each controller.

SYSLOOP - MODBUS

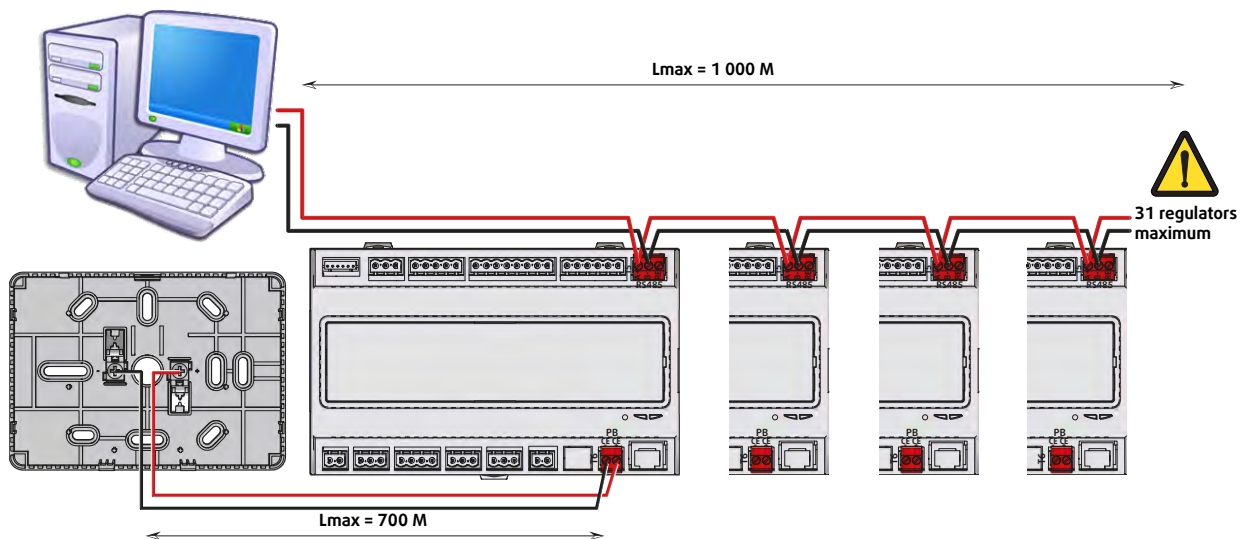

16. REGULATION

SYSLOOP units are fitted with an electronic control system. It provides the command, control and alarm functions.

16.1. ORDER OF PRIORITY FOR CONTROL SYSTEMS

The integrated regulator in the **SYSLOOP** can be controlled by various interfaces and systems. The order of priority for each drive system is as follows:

1. Timing programming: this scheduling is integrated in the regulator
2. The BMS : the remote supervision transmits it commands according to the communication protocols
3. The all remote control: the commands are given by the user directly on the unit
4. Digital inputs: the client can transmit commands electro-mechanically over 2 dry contacts:

- ✓ Input D1: ON/OFF
- ✓ Input D2: configurable



16.2. WALL-MOUNTED CONTROL

This control is a liquid crystal display with 8 buttons.

It enables the end user to interface with the unit:

- activation
- setpoint change
- ventilation speed
- alarm code...

It also includes a temperature sensor to measure the ambient temperature.

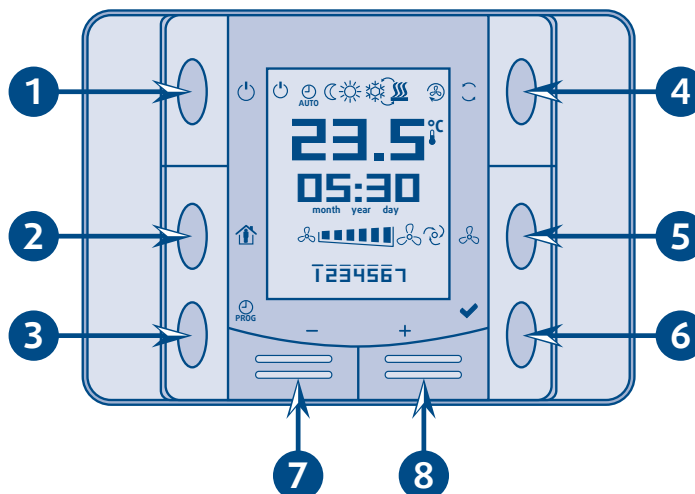

16.2.1. KEYPAD

	Name	Icons	Functions
1	ON/OFF		Briefly press to switch the unit on or off. Press and hold to activate scheduling. To disable the time programming, press briefly.
2	Eco/Comfort modes		Briefly press to toggle from eco to comfort mode.
3	Scheduling Time settings		Press and hold to set the unit's date and time. When the minutes are set, the unit displays the normal operating screen. Briefly press to access time programming.
4	Operating mode		Briefly press to change the operating mode. COOL/HEAT/AUTO CHANGEOVER/VENTILATION In auto-changeover mode, the control displays the active temperature control mode.
5	Ventilation		Press to modify the ventilation speed. As EC fan speed gradually changes, there may be a lapse of time before the required speed is reached.
6	Confirmation		Confirms the modification of a setting
7	-		Edits the value of a setting when it is selected.
8	+		

16.2.2. SCREEN



Icons	Meanings
	SYSLOOP off
	Hourly programming active
	Operation in Eco mode
	Operation in Comfort mode
	COOL mode
	HEAT Mode
	Auto-changeover mode. The control displays the active heat or control mode.
	Ventilation only
23.5°C	When the unit is off, the temperature displayed is that measured by the control's internal sensor. When the unit is on, the temperature displayed is that of the setting set by the user.
05:30	System time
	Fan speed In all modes, the number of bars shows the fan's actual operating speed. As EC fan speed gradually changes, there may be a lapse of time before the required speed is reached. The symbol indicates that the ventilation speed is controlled automatically.
1234567	Scheduling day and time slot

16.2.3. TIME SETTINGS

Press and hold the button to set the unit's date and time. Set in the following sequence: year, month, day, hour, minutes. When the minutes are set, the unit displays the normal operating screen.

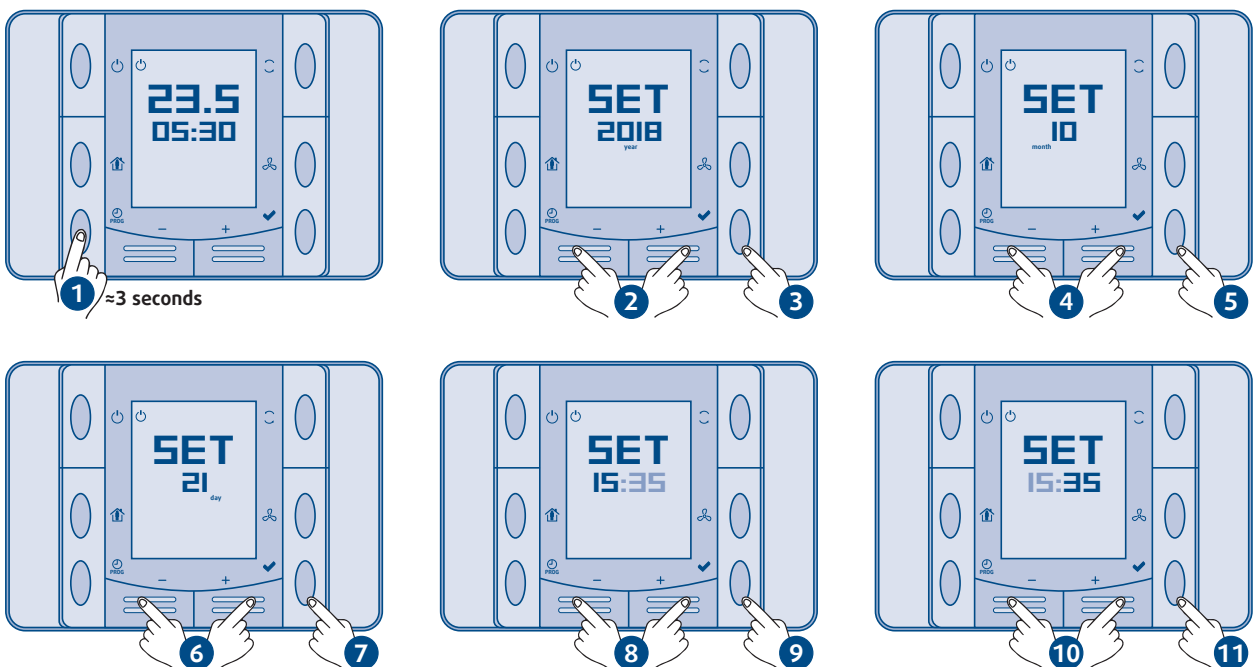

This setting is important for the alarm log as well as to display the time on the room thermostat.



Caution

A power outage leads to the loss of time after 6 hours.

16.2.4. SCHEDULING

Scheduling is used to select the unit activation and shutdown times. Each day is broken down into 6 time slots set by

- A start time
- A state: ON or OFF

To open the time programming, briefly press the  button.

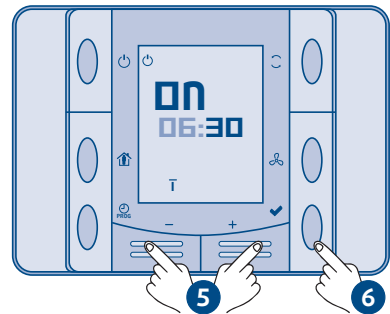
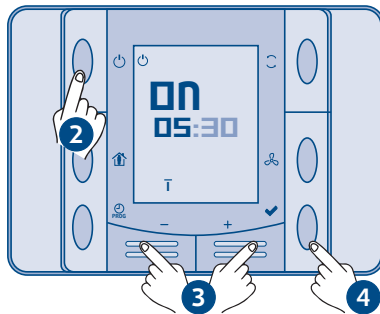
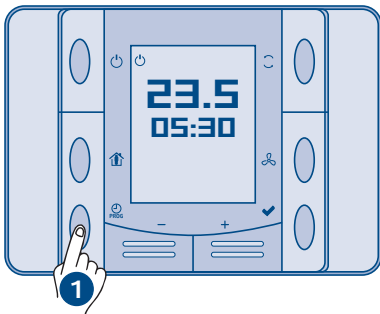

Once the time is confirmed, the following slot is displayed

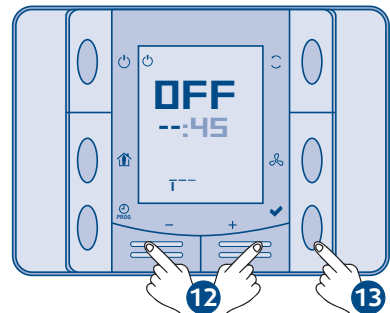
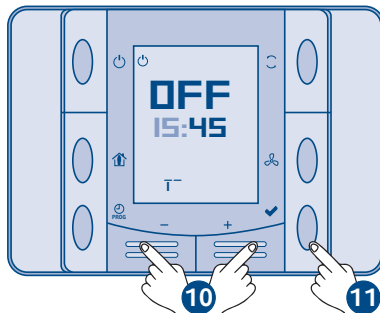
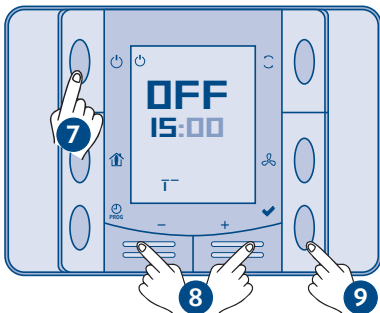

To disable a time slot, replace the time with "--:--"

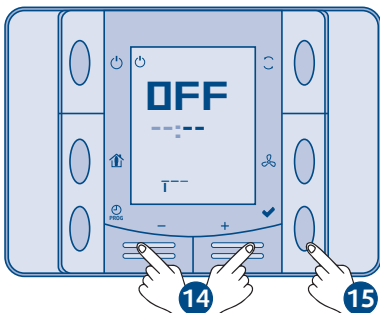

Once the 6 slots confirmed, the first slot of the day is displayed.

 **Information**

To close, you can briefly press the  button again.

 **Information**

After an idle period of 30s, the time programming menu will close, but all the changes will be saved.

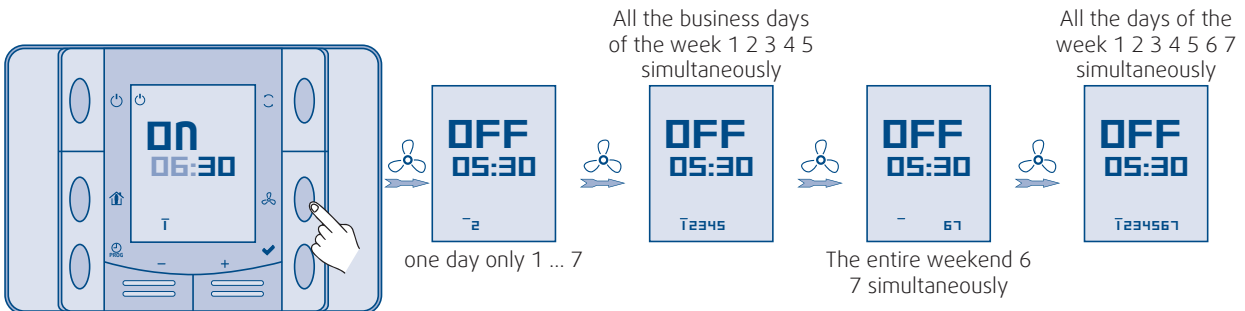

If the unit is in time programming mode, the unit will switch to the mode shown in the current slot until the next slot begins. Its state will then be the one of the future slot.

17. FINAL TASKS

Place the plugs back on the valves and check that they are properly tightened.

If needed, fix the cables and the pipes on the wall with clamping collars.

Operate the **SYSLOOP** in the presence of the user and explain all functions.

Show him how to remove, clean and place back the filters.

18. STARTING - RECOMMENDATIONS - SETTINGS

1. Check that all the water valves are open and that water circulates in the appliance before making any demand for heating or cooling.
2. Ensure that the units are connected correctly to the mains power supply (Refer to the § **ELECTRICAL POWER SUPPLY**, page 8 and in § **WIRING DIAGRAM**, page XII) f
3. Before attempting any start-up, ensure that the air and water temperatures are within the appliance's operating limits (in § **OPERATING LIMITS**, page 7).
4. Rotate the fan by hand to ensure that it turns freely and that the fan turbine is properly attached to the motor shaft.
5. Check that the condensates drainage pipe is properly attached and free of any blockages.
6. Check the correct positioning of the filters and that they are clean and accessible.
7. Ensure that the finned heat exchanger surfaces are clean. Clean if required.
8. Check that the connection hoses are correctly fitted and ensure that the appliance's water circuit has been correctly bled of any air.
9. Ensure that no Alarm code is displayed when the mains power supply is switched on (Refer to the § **ALARM CODES**, page 29).
10. Carry out the usual checks on the main water loop and particularly to ensure that the water circulation pump operates correctly.



Caution

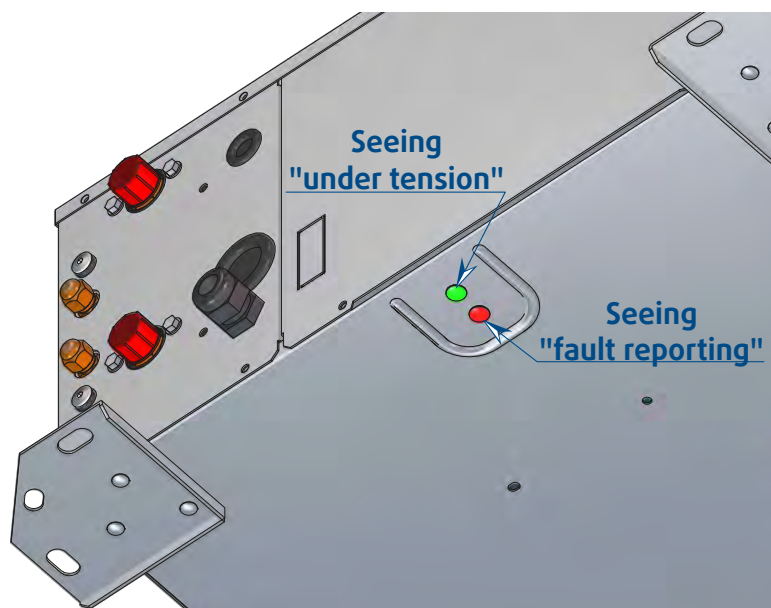

Non-compliance with this rule may result in irreversible damage. In addition, we recommend the use of a flow controller on the units' inlet pipe (not supplied).





18.1. COMMISSIONING

After performing all the above-mentioned checks, proceed with creating a demand for Cooling and Heating or vice versa.

18.1.1. DEMAND FOR COOLING

1. With the key  on the control module, select COOL mode  and then set the minimum temperature with the UP and DOWN arrows. The ambient temperature should be within the operating limits (Refer to the § **OPERATING LIMITS**, page 7). In the same way, during the pre-commissioning checks, the exchanger pump(s) water loop inlet temperature should be within the limits corresponding to each operating mode (Refer to the § **OPERATING LIMITS**, page 7).
Reminder: if one of these factors is situated at its minimum or maximum level, the other should be situated at a normal level in order to ensure the unit's correct and normal operation.
2. Ensure that the thermostat is connected properly and set the set temperature below the ambient temperature of the zone to be cooled. After 3 minutes, the compressor starts operating.
3. When the appliance has been operating for a few minutes, check the presence of cold air at the blowing grille.
4. When the appliance has been operating for a few minutes, check the temperature of the unit's outlet water. Generally, this should be around 5°C above the unit's water loop inlet temperature. A variance lower than 3.5°C indicates that the water flow is too high, whilst a variance higher than 8°C indicates that the water flow is too low.
5. Adjust the isolation/balancing valve on the outlet water pipe to obtain the appliance's nominal water flow (Refer to the Maker's Plate)
6. Check that the condensates drainage system is working properly and check that a siphon is included in the drainage line.
7. Check for the absence of vibrations and water leaks.
8. When all the above tests have been completed, adjust the system to maintain the desired comfort level.

18.1.2. DEMAND FOR HEATING

1. With the key  on the control modules, select HEAT mode  and then set the maximum temperature with the UP and DOWN arrows. The ambient temperature should be within the operating limits (Refer to the § **OPERATING LIMITS**, page 7). In the same way, during the pre-commissioning checks the exchanger pump(s) water loop inlet temperature should be within the limits corresponding to each operating mode (Refer to the § **OPERATING LIMITS**, page 7).
Reminder: if one of these factors is situated at its minimum or maximum level, the other should be situated at a normal level in order to ensure the unit's correct and normal operation.
2. Ensure that the thermostat is connected properly and set the set temperature above the ambient temperature of the zone to be cooled. After 3 minutes, the compressor starts operating.
3. When the appliance has been operating for a few minutes, check the presence of hot air at the blowing grille.
4. When the appliance has been operating for a few minutes, check the temperature of the unit's outlet water. Generally, this should be around 3°C below the unit's water loop inlet temperature. A variance lower than 2°C indicates that the water flow is too high, whilst a variance higher than 6°C indicates that the water flow is too low.
5. Adjust the isolation/balancing valve on the outlet water pipe to obtain the appliance's nominal water flow (Refer to the Maker's Plate)
6. Check for the absence of vibrations and water leaks.
7. When all the above tests have been completed, adjust the system to maintain the desired comfort level.

Note: If the unit does not operate, perform a fault diagnosis (Refer to the § **MAINTENANCE AND SERVICING**, page 27). If the fault analysis does not enable the cause of the problem(s) to be determined or if the unit still does not operate, contact a qualified after-sales technician to obtain a correct diagnosis and to repair the equipment.

19. MAINTENANCE AND SERVICING

1. Normal maintenance of the appliances is generally limited to replacing filters.
2. The filters must be changed at regular intervals. The frequency is dependent on the specific application conditions. Certain installations, for example in hotels where there large amounts of fluff due to the frequent bedding changes and the presence of fitted carpets, require more frequent filter changes. It is recommended that the filters are checked every 60 days during the first year of operation in order to determine the frequency required. If it is not possible to see light through the filter when it is held up to the sun or in front of a strong light, the filter must be replaced. A more rigorous standard of cleanliness may be required.
3. The condensates tray must be checked annually and cleaned and rinsed if necessary.
4. Pressure checks are performed by means of the LP and HP pressures take-offs on the fascia. The gas contained in the pressure gauge hoses must be re-injected as the gas charge is very low.
5. On commissioning, a record of voltages, current draw and temperature variances should be made. Thereafter, on an annual basis further measurements can be compared to these initial values and will be useful for giving an overall indication for the equipment's general condition.
6. The activation of the unit's safety protection devices is usually caused by air or water problems. These forced stoppages are a normal protection measure. Ensure that there is no dirt or debris in the air or water circuits. Check the water and air temperatures and flows (clogged filters).



CAUTION

BEFORE CARRYING OUT ANY OPERATION ON THE EQUIPMENT, CHECK THAT THE ELECTRICAL POWER SUPPLY IS SWITCHED OFF AND THAT IT CANNOT BE SWITCHED ON INADVERTENTLY.

19.1. FAULT FINDING

19.1.1. NEITHER THE FAN NOR THE COMPRESSOR OPERATE

1. The system is in alarm mode when the mains power supply is switched on. Check the points mentioned in § **ALARM CODES**, page 29 for diagnosis.
2. Check the wiring of the remote control.
3. Check that the appliance is properly set in COOL, HEAT or FAN mode.
4. Check the condition of the fuse or the mains power supply. Check the compressor and fan wiring.
5. Check for any loose or broken wiring and tighten or replace as required.
6. The mains supply voltage is too low. If this is the case, check the supply conditions with the electricity provider.

19.1.2. VENTILATION (FAN) MODE OPERATES BUT THE COMPRESSOR DOES NOT OPERATE

1. For Single Phase versions, check the current available and the wiring.
2. Check for any loose or broken wiring and tighten or replace as required.
3. Check that the machine is not in alarm mode. Refer to the § **ALARM CODES**, page 29 for diagnosis.
4. Check the thermostat's set temperature point.
5. The compressor may be grounded, in which case replace the compressor.
6. The internal compressor circuit is open circuit, perform a continuity test with an Ohmmeter. If the circuit is open circuit, replace the compressor.

19.1.3. INSUFFICIENT COOLING OR HEATING PRODUCTION

1. Check that the thermostat is properly located in the zone to be heated or cooled and that it is not near to a source of cold or heat that may influence the reading.
2. Check the proper operation of the Return Air Temperature (RT) sensor, located on the fin exchanger.
3. Airflow is insufficient. Check for clogged filters. Clean and replace as required.
4. The cycle inversion valve may be defective and be creating a refrigerant by-pass. If the unit does not produce heat, check the wiring of the inversion valve coil.
5. Check the proper operation of the pressure relief valve.
6. Measure the water flow on the water loop.
7. Check the configuration of the appliance.

19.1.4. INSUFFICIENT WATER FLOW AT THE LEVEL OF THE COAXIAL EXCHANGER.

1. Check for proper water circulation at the level of the water circulation pump.
2. If a valve is fitted to the water loop, check that it is open.
3. Check that air is not being sucked into the hydraulic system. Bleed the system if required.

19.1.5. APPEARANCE OF WATER DROPLETS IN THE APPLIANCE

1. Check that the condensates drainage pipe is not blocked and that water drains away normally.
2. Check the correct operation of the condensates tray anti-overflow float (Refer to the § **ALARM CODES**, page 29).
3. Check that the float moves freely on its rod. If this is not the case, clean the tray and the float.
4. Check the cleanliness of the filters.

19.1.6. APPEARANCE OF ABNORMAL NOISES AND VIBRATIONS IN THE CASING

1. Check that the turbine is not rubbing against the scroll and that the latter is not damaged. Replace as required.
 2. Check that the turbine has not worked loose on its shaft. Centre the turbine and tighten it as required.
 3. Check that the compressor is mounted correctly on its shock pads.
 4. Check that no part of the turbine rubs against the compressor or any other surface. Reposition slightly as required.
 5. Check that all the attachment screws are tightened properly.
 6. Check that air is not being sucked into the hydraulic system.
 7. Test that the relays open and close correctly. Replace as required.
-

19.2. ALARM CODES

Code	Type	Message
0	alarm	HP pressure switch
		LP pressure switch
		water min. temperature cool mode
		water max. temperature cool mode
		water min. temperature heat mode
		water max. temperature heat mode
1	alarm	RAT sensor defective
2	alarm	ICT sensor defective
3	alarm	LWT sensor defective
4	alarm	hot air/coolant battery
5	alarm	fan off
		fan lock-out
6	alarm	cool air/coolant battery
7	lock-out	HP pressure switch
8	lock-out	LP pressure switch
9	lock-out	water min. temperature cool mode
10	lock-out	water max. temperature cool mode
11	lock-out	water min. temperature heat mode
12	lock-out	water max. temperature heat mode
13	alarm	flowswitch/condensate
		flowswitch/condensate lock-out

20. IN CASE OF WARRANTY - MATERIAL RETURN PROCEDURE

Material must not be returned without permission of our After Sales Department.

To return the material, contact your nearest sales office and ask for a "return form". The return form shall be sent with the returned material and shall contain all necessary information concerning the problem encountered.

The return of the part is not an order for replacement. Therefore, a purchase order must be entered through your nearest distributor or regional sales office. The order should include part name, part number, model number and serial number of the unit involved.

Following our personal inspection of the returned part, and if it is determined that the failure is due to faulty material or workmanship, and in warranty, credit will be issued on customer's purchase order. All parts shall be returned to our factory, **transportation charges prepaid**.

21. ORDERING SERVICE AND SPARE PARTS ORDER

The part number, the order confirmation and the unit serial number indicated on the name plate must be provided whenever service works or spare parts are ordered.

For any spare part order, indicate the date of unit installation and date of failure. Use the part number provided by our service spare parts, if it not available, provide full description of the part required.

APPENDIX
ANNEXE
ANLAGE
ALLEGATO
ANEXO

APPENDIX

DIMENSIONS	III	CONFIGURATION R1.AI 1Ø200/S4.AO 1Ø200 OR	
CONFIGURATION R1.AI RECT/S4.AO RECT	III	R1.AI 1Ø200 FAØ100/S4.AO 1Ø200 OR	
CONFIGURATION R2.AI RECT/S4.AO RECT	IV	R1.AI 1Ø200 FAØ125/S4.AO 1Ø200 OR	
CONFIGURATION R1.AI 1Ø200/S4.AO RECT OR		R1.AI 1Ø200/S3.AO 1Ø200 OR	
R1.AI 1Ø200 FAØ100/S4.AO RECT OR		R1.AI 1Ø200 FAØ100/S3.AO 1Ø200 OR	
R1.AI 1Ø200 FAØ125/S4.AO RECT	V	R1.AI 1Ø200 FAØ125/S3.AO 1Ø200	IX
CONFIGURATION R2.AI 1Ø200/S4.AO RECT OR		CONFIGURATION R2.AI 1Ø200/S4.AO 1Ø200 OR	
R2.AI 1Ø200 FAØ100/S4.AO RECT OR		R2.AI 1Ø200 FAØ100/S4.AO 1Ø200 OR	
R2.AI 1Ø200 FAØ125/S4.AO RECT	VI	R2.AI 1Ø200 FAØ125/S4.AO 1Ø200 OR	
CONFIGURATION R1.AI RECT/S4.AO 1Ø200 OR		R2.AI 1Ø200/S3.AO 1Ø200 OR	
R1.AI RECT/S3.AO 1Ø200	VII	R2.AI 1Ø200 FAØ100/S3.AO 1Ø200 OR	
CONFIGURATION R2.AI RECT/S4.AO 1Ø200 OR		R2.AI 1Ø200 FAØ125/S3.AO 1Ø200	X
R2.AI RECT/S3.AO 1Ø200	VIII	CONFIGURATION AO XLN	XI
		WIRING DIAGRAM	XII
		LEGEND	XIII

ANNEXE

DIMENSIONS	III	CONFIGURATION R1.AI 1Ø200/S4.AO 1Ø200 OU	
CONFIGURATION R1.AI RECT/S4.AO RECT	III	R1.AI 1Ø200 FAØ100/S4.AO 1Ø200 OU	
CONFIGURATION R2.AI RECT/S4.AO RECT	IV	R1.AI 1Ø200 FAØ125/S4.AO 1Ø200 OU	
CONFIGURATION R1.AI 1Ø200/S4.AO RECT OU		R1.AI 1Ø200/S3.AO 1Ø200 OU	
R1.AI 1Ø200 FAØ100/S4.AO RECT OU		R1.AI 1Ø200 FAØ100/S3.AO 1Ø200 OU	
R1.AI 1Ø200 FAØ125/S4.AO RECT	V	R1.AI 1Ø200 FAØ125/S3.AO 1Ø200	IX
CONFIGURATION R2.AI 1Ø200/S4.AO RECT OU		CONFIGURATION R2.AI 1Ø200/S4.AO 1Ø200 OU	
R2.AI 1Ø200 FAØ100/S4.AO RECT OU		R2.AI 1Ø200 FAØ100/S4.AO 1Ø200 OU	
R2.AI 1Ø200 FAØ125/S4.AO RECT	VI	R2.AI 1Ø200 FAØ125/S4.AO 1Ø200 OU	
CONFIGURATION R1.AI RECT/S4.AO 1Ø200 OU		R2.AI 1Ø200/S3.AO 1Ø200 OU	
R1.AI RECT/S3.AO 1Ø200	VII	R2.AI 1Ø200 FAØ100/S3.AO 1Ø200 OU	
CONFIGURATION R2.AI RECT/S4.AO 1Ø200 OU		R2.AI 1Ø200 FAØ125/S3.AO 1Ø200	X
R2.AI RECT/S3.AO 1Ø200	VIII	CONFIGURATION AO XLN	XI
		SCHEMAS ELECTRIQUES	XII
		LEGENDE	XIII

ANLAGE

ABMESSUNGEN	III	CONFIGURATION R1.AI 1Ø200/S4.AO 1Ø200 ODER	
KONFIGURATION R1.AI RECT/S4.AO RECT	III	R1.AI 1Ø200 FAØ100/S4.AO 1Ø200 ODER	
KONFIGURATION R2.AI RECT/S4.AO RECT	IV	R1.AI 1Ø200 FAØ125/S4.AO 1Ø200 ODER	
KONFIGURATION R1.AI 1Ø200/S4.AO RECT ODER		R1.AI 1Ø200/S3.AO 1Ø200 ODER	
R1.AI 1Ø200 FAØ100/S4.AO RECT ODER		R1.AI 1Ø200 FAØ100/S3.AO 1Ø200 ODER	
R1.AI 1Ø200 FAØ125/S4.AO RECT	V	R1.AI 1Ø200 FAØ125/S3.AO 1Ø200	IX
KONFIGURATION R2.AI 1Ø200/S4.AO RECT ODER		KONFIGURATION R2.AI 1Ø200/S4.AO 1Ø200 ODER	
R2.AI 1Ø200 FAØ100/S4.AO RECT ODER		R2.AI 1Ø200 FAØ100/S4.AO 1Ø200 ODER	
R2.AI 1Ø200 FAØ125/S4.AO RECT	VI	R2.AI 1Ø200 FAØ125/S4.AO 1Ø200 ODER	
KONFIGURATION R1.AI RECT/S4.AO 1Ø200 ODER		R2.AI 1Ø200/S3.AO 1Ø200 ODER	
R1.AI RECT/S3.AO 1Ø200	VII	R2.AI 1Ø200 FAØ100/S3.AO 1Ø200 ODER	
KONFIGURATION R2.AI RECT/S4.AO 1Ø200 ODER		R2.AI 1Ø200 FAØ125/S3.AO 1Ø200	X
R2.AI RECT/S3.AO 1Ø200	VIII	KONFIGURATION AO XLN	XI
		STROMLAUFPLANS	XII
		ERLÄUTERUNG	XIII

ALLEGATO

DIMENSIONI	III	CONFIGURAZIONE R1.AI 1Ø200/S4.AO 1Ø200 O	
CONFIGURAZIONE R1.AI RECT/S4.AO RECT	III	R1.AI 1Ø200 FAØ100/S4.AO 1Ø200 O	
CONFIGURAZIONE R2.AI RECT/S4.AO RECT	IV	R1.AI 1Ø200 FAØ125/S4.AO 1Ø200 O	
CONFIGURAZIONE R1.AI 1Ø200/S4.AO RECT O		R1.AI 1Ø200/S3.AO 1Ø200 O	
R1.AI 1Ø200 FAØ100/S4.AO RECT O		R1.AI 1Ø200 FAØ100/S3.AO 1Ø200 O	
R1.AI 1Ø200 FAØ125/S4.AO RECT	V	R1.AI 1Ø200 FAØ125/S3.AO 1Ø200	IX
CONFIGURAZIONE R2.AI 1Ø200/S4.AO RECT O		CONFIGURAZIONE R2.AI 1Ø200/S4.AO 1Ø200 O	
R2.AI 1Ø200 FAØ100/S4.AO RECT O		R2.AI 1Ø200 FAØ100/S4.AO 1Ø200 O	
R2.AI 1Ø200 FAØ125/S4.AO RECT	VI	R2.AI 1Ø200 FAØ125/S4.AO 1Ø200 O	
CONFIGURAZIONE R1.AI RECT/S4.AO 1Ø200 O		R2.AI 1Ø200/S3.AO 1Ø200 O	
R1.AI RECT/S3.AO 1Ø200	VII	R2.AI 1Ø200 FAØ100/S3.AO 1Ø200 O	
CONFIGURAZIONE R2.AI RECT/S4.AO 1Ø200 O		R2.AI 1Ø200 FAØ125/S3.AO 1Ø200	X
R2.AI RECT/S3.AO 1Ø200	VIII	CONFIGURAZIONE AO XLN	XI
		SCHEMA ELETRICO	XII
		LEGGENDA	XIII

ANEXO

DIMENSIONES	III	CONFIGURACIÓN R1.AI 1Ø200/S4.AO 1Ø200 O	
CONFIGURACIÓN R1.AI RECT/S4.AO RECT	III	R1.AI 1Ø200 FAØ100/S4.AO 1Ø200 O	
CONFIGURACIÓN R2.AI RECT/S4.AO RECT	IV	R1.AI 1Ø200 FAØ125/S4.AO 1Ø200 O	
CONFIGURACIÓN R1.AI 1Ø200/S4.AO RECT O		R1.AI 1Ø200/S3.AO 1Ø200 O	
R1.AI 1Ø200 FAØ100/S4.AO RECT O		R1.AI 1Ø200 FAØ100/S3.AO 1Ø200 O	
R1.AI 1Ø200 FAØ125/S4.AO RECT	V	R1.AI 1Ø200 FAØ125/S3.AO 1Ø200	IX
CONFIGURACIÓN R2.AI 1Ø200/S4.AO RECT O		CONFIGURACIÓN R2.AI 1Ø200/S4.AO 1Ø200 O	
R2.AI 1Ø200 FAØ100/S4.AO RECT O		R2.AI 1Ø200 FAØ100/S4.AO 1Ø200 O	
R2.AI 1Ø200 FAØ125/S4.AO RECT	VI	R2.AI 1Ø200 FAØ125/S4.AO 1Ø200 O	
CONFIGURACIÓN R1.AI RECT/S4.AO 1Ø200 O		R2.AI 1Ø200/S3.AO 1Ø200 O	
R1.AI RECT/S3.AO 1Ø200	VII	R2.AI 1Ø200 FAØ100/S3.AO 1Ø200 O	
CONFIGURACIÓN R2.AI RECT/S4.AO 1Ø200 O		R2.AI 1Ø200 FAØ125/S3.AO 1Ø200	X
R2.AI RECT/S3.AO 1Ø200	VIII	CONFIGURACIÓN AO XLN	XI
		ESQUEMA ELECTRICO	XII
		LEYENDA	XIII

DIMENSIONS
DIMENSIONS
ABMESSUNGEN
DIMENSIONI
DIMENSIONES

CONFIGURATION R1.AI RECT/S4.AO RECT

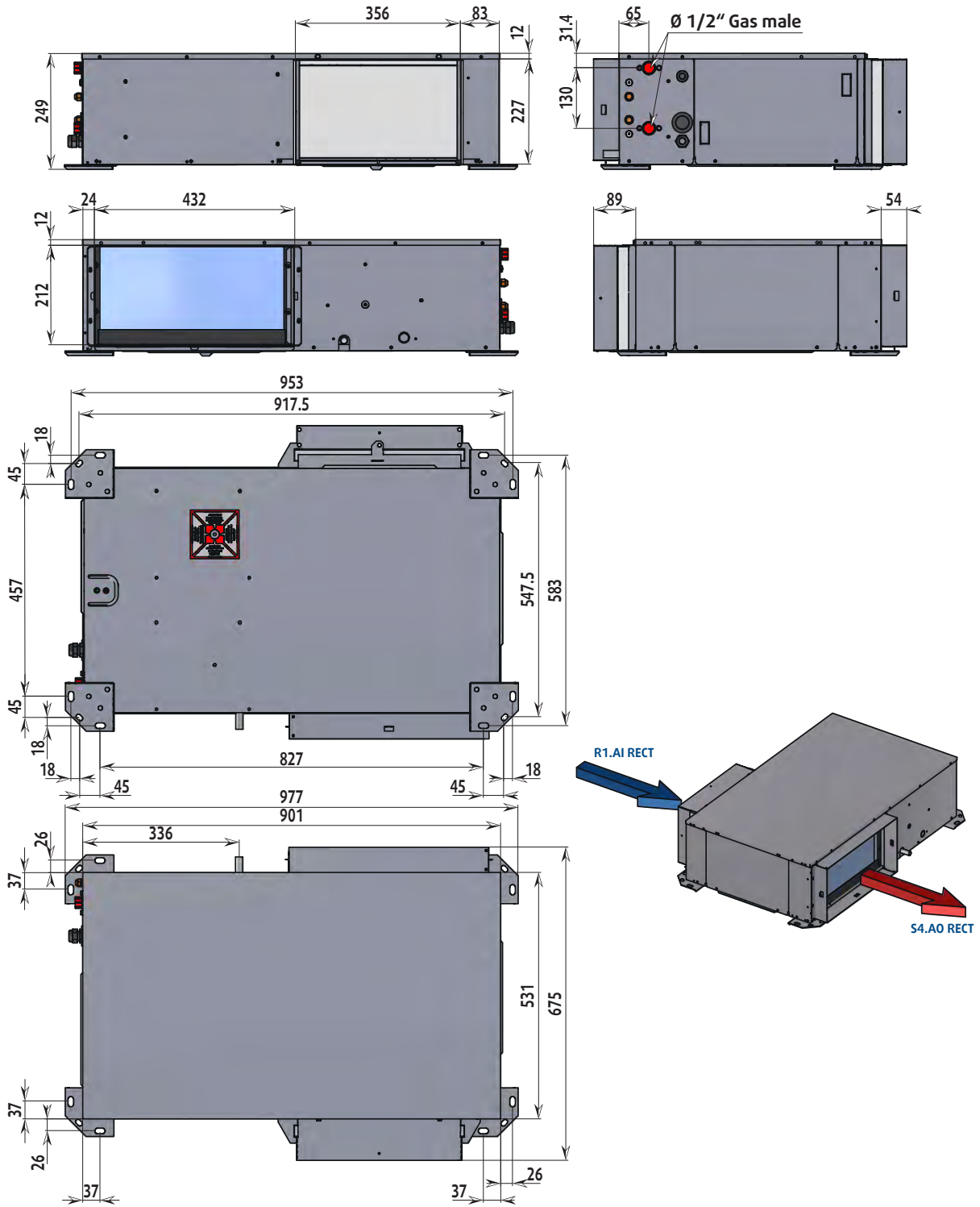

APPENDIX / ANNEXE / ANLAGE / ALLEGATO / ANEXO

CONFIGURATION R2.AI RECT/S4.AO RECT

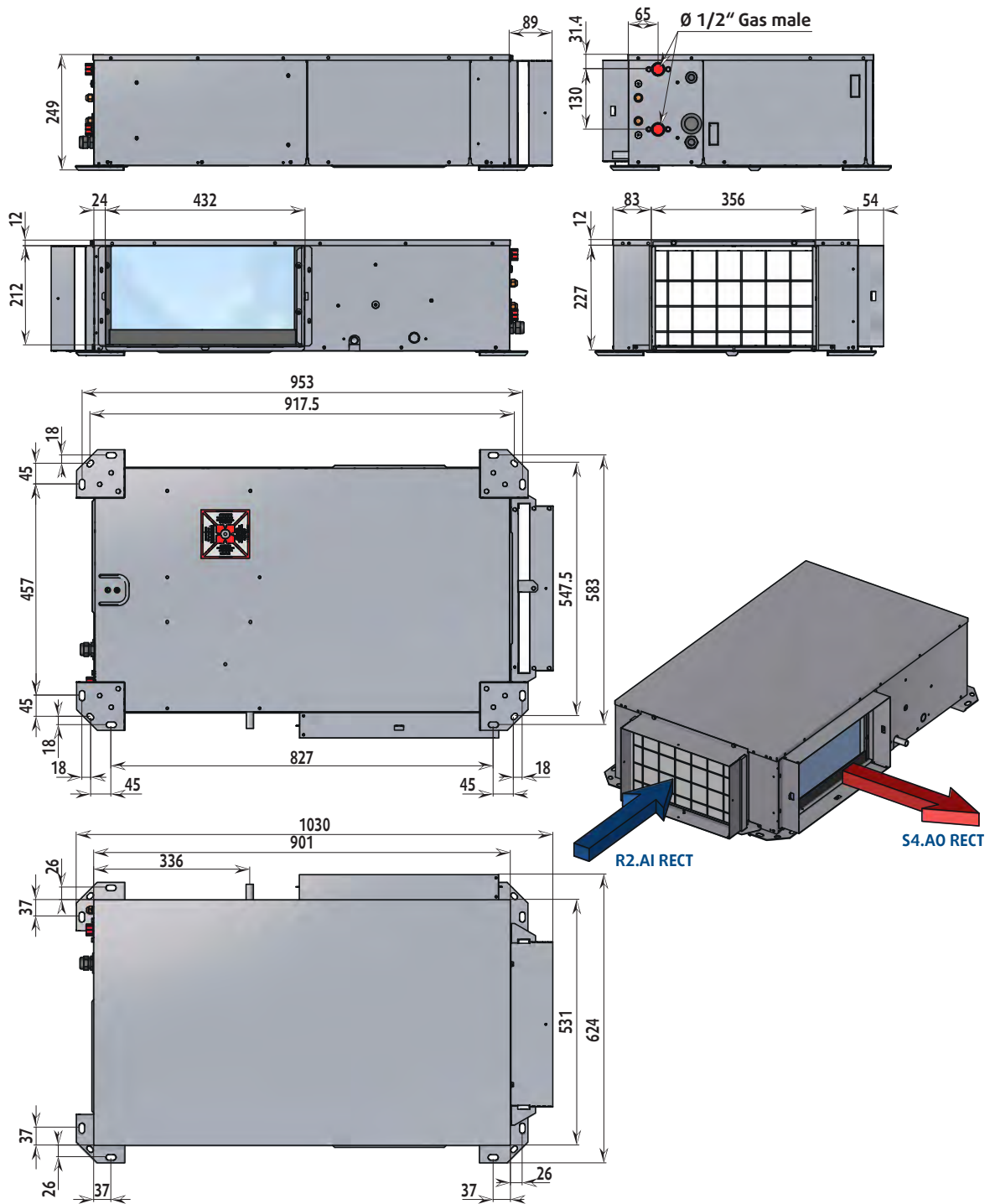

APPENDIX / ANNEXE / ANLAGE / ALLEGATO / ANEXO

CONFIGURATION R1.AI 1Ø200/S4.AO RECT OR R1.AI 1Ø200 FAØ100/S4.AO RECT OR R1.AI 1Ø200 FAØ125/S4.AO RECT

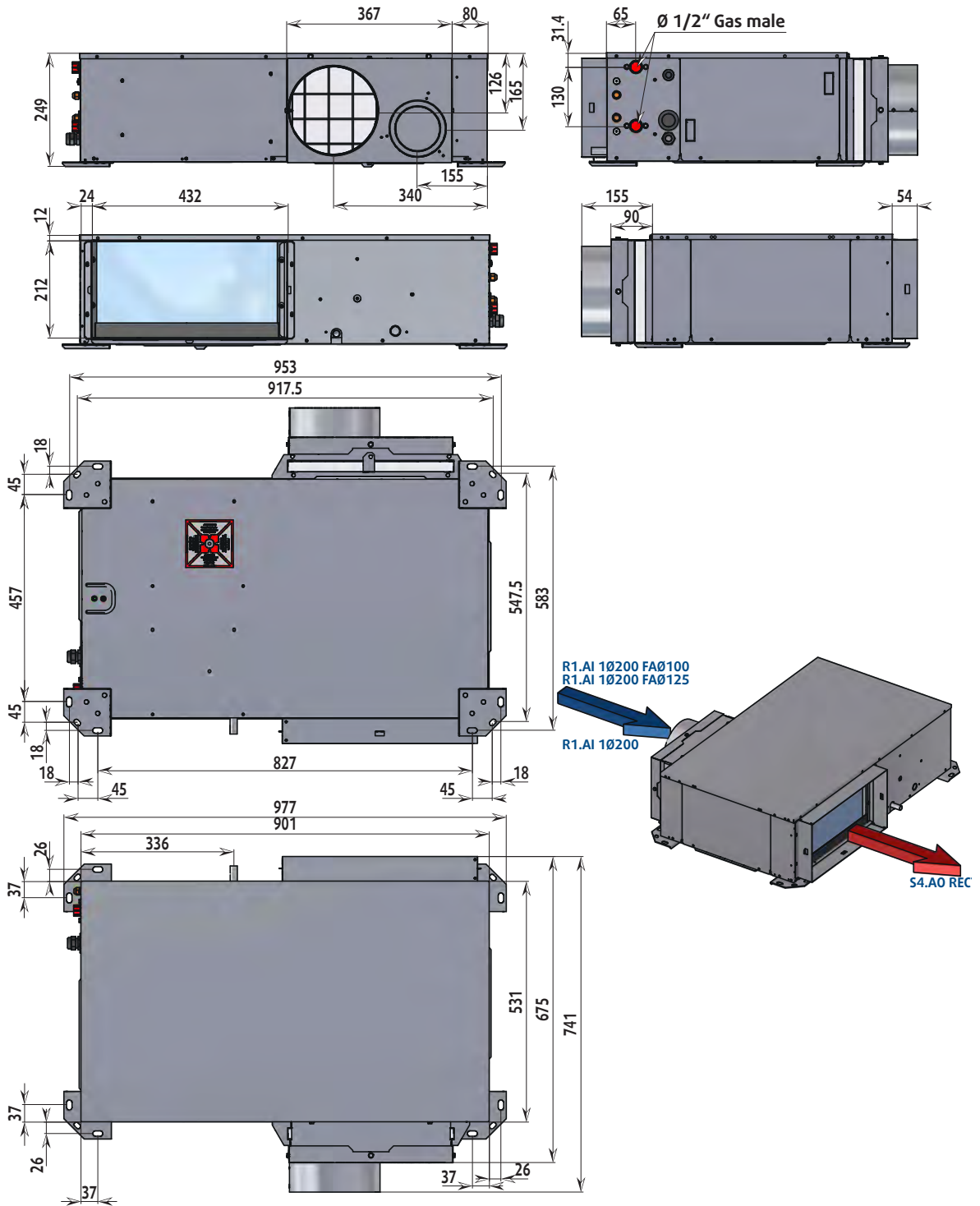

APPENDIX / ANNEXE / ANLAGE / ALLEGATO / ANEXO

CONFIGURATION R2.AI 1Ø200/S4.AO RECT OR R2.AI 1Ø200 FAØ100/S4.AO RECT OR R2.AI 1Ø200 FAØ125/S4.AO RECT

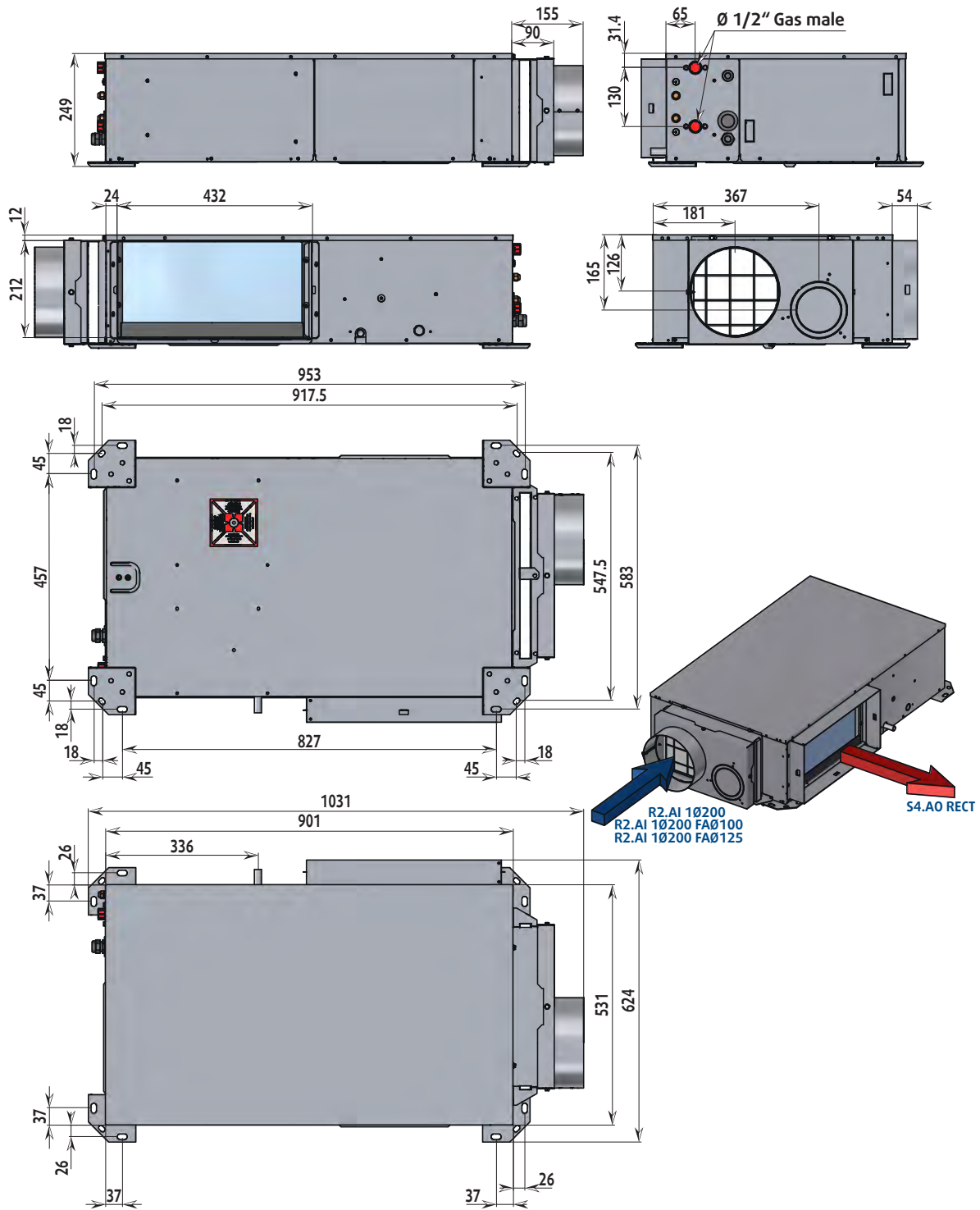

APPENDIX / ANNEXE / ANLAGE / ALLEGATO / ANEXO

CONFIGURATION R1.AI RECT/S4.AO 1Ø200 OR R1.AI RECT/S3.AO 1Ø200

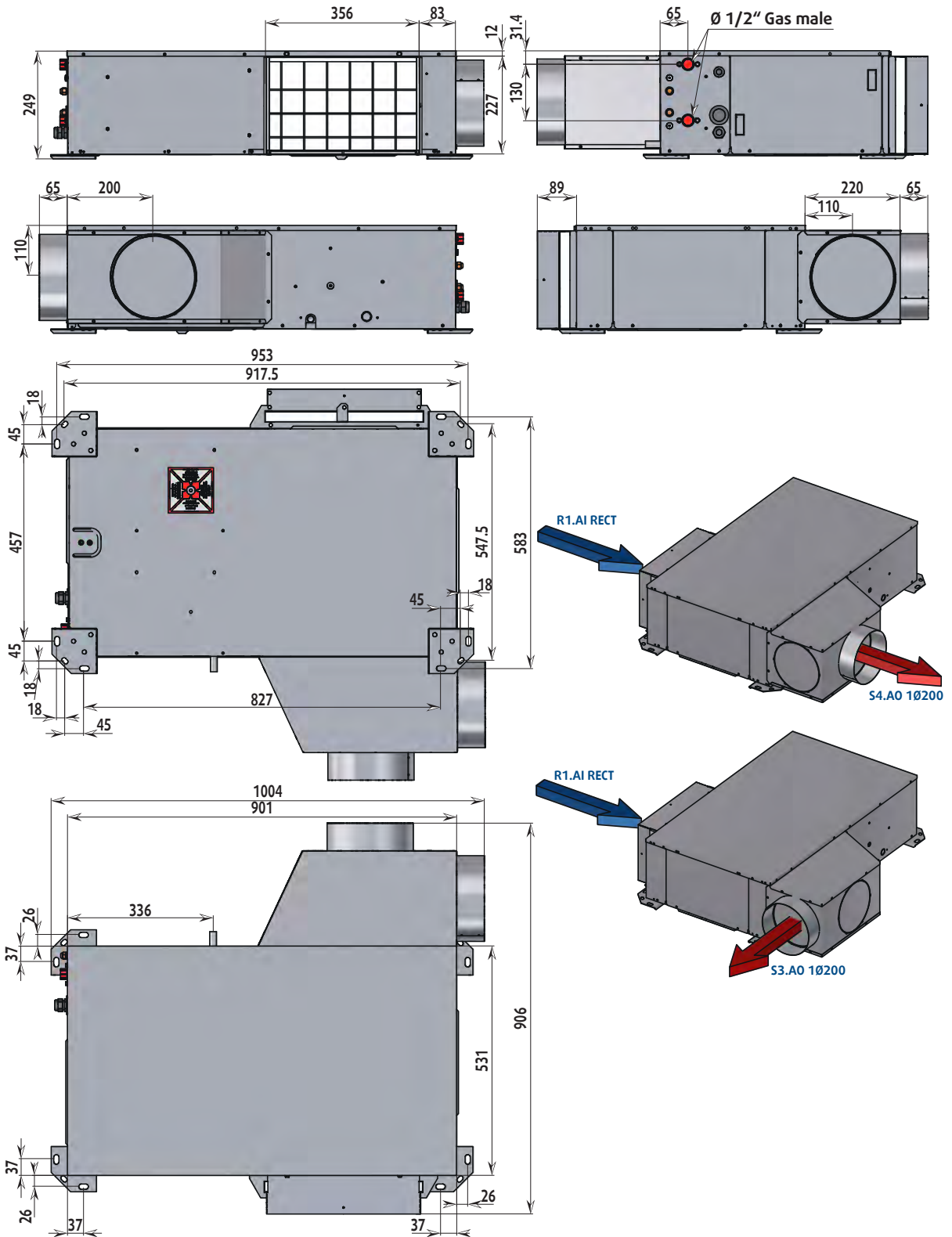

APPENDIX / ANNEXE / ANLAGE / ALLEGATO / ANEXO

CONFIGURATION R2.AI RECT/S4.AO 1Ø200 OR R2.AI RECT/S3.AO 1Ø200

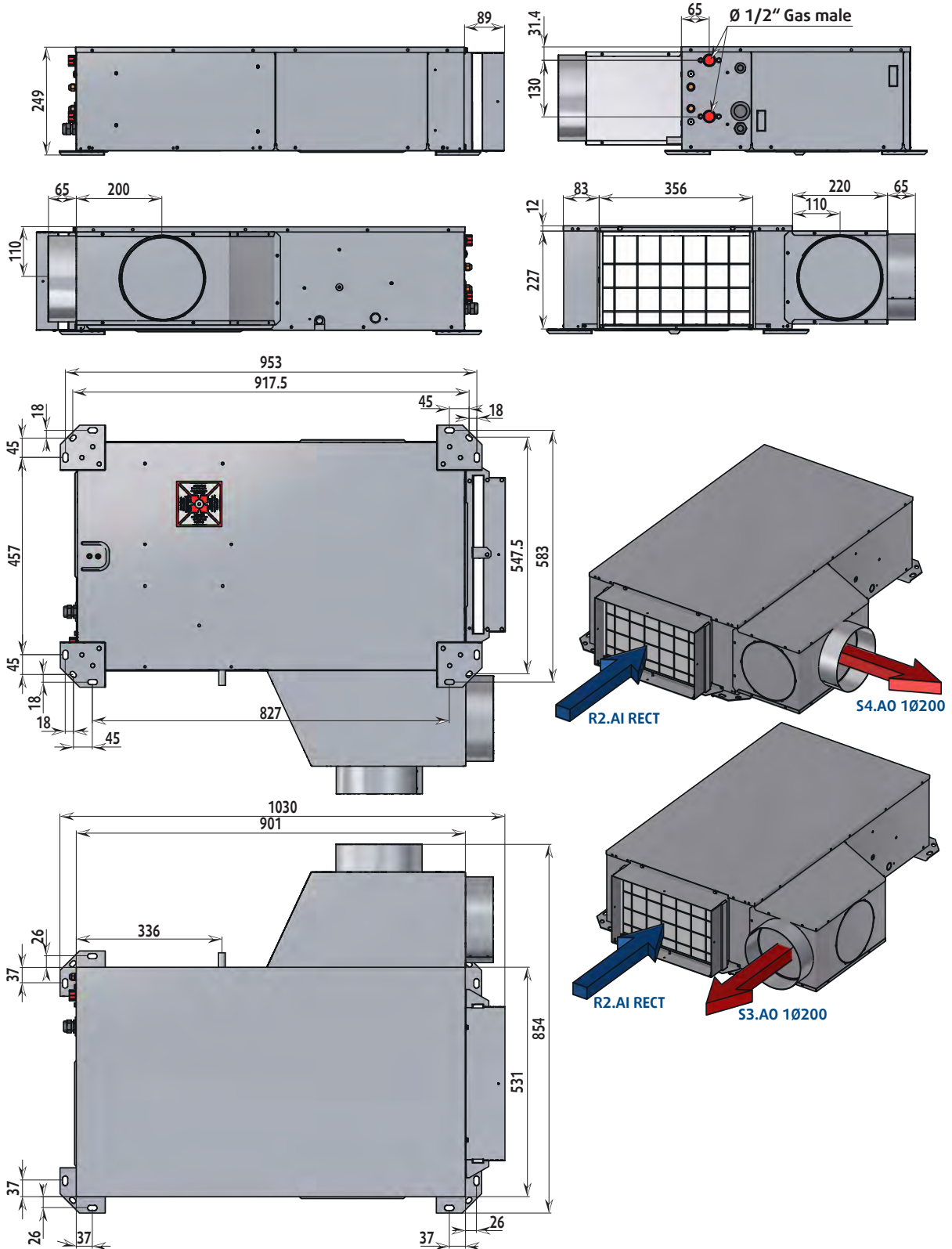

APPENDIX / ANNEXE / ANLAGE / ALLEGATO / ANEXO

CONFIGURATION R1.AI 1Ø200/S4.AO 1Ø200 OR R1.AI 1Ø200 FAØ100/S4.AO 1Ø200 OR R1.AI 1Ø200 FAØ125/S4.AO 1Ø200 OR R1.AI 1Ø200/S3.AO 1Ø200 OR R1.AI 1Ø200 FAØ100/S3.AO 1Ø200 OR R1.AI 1Ø200 FAØ125/S3.AO 1Ø200

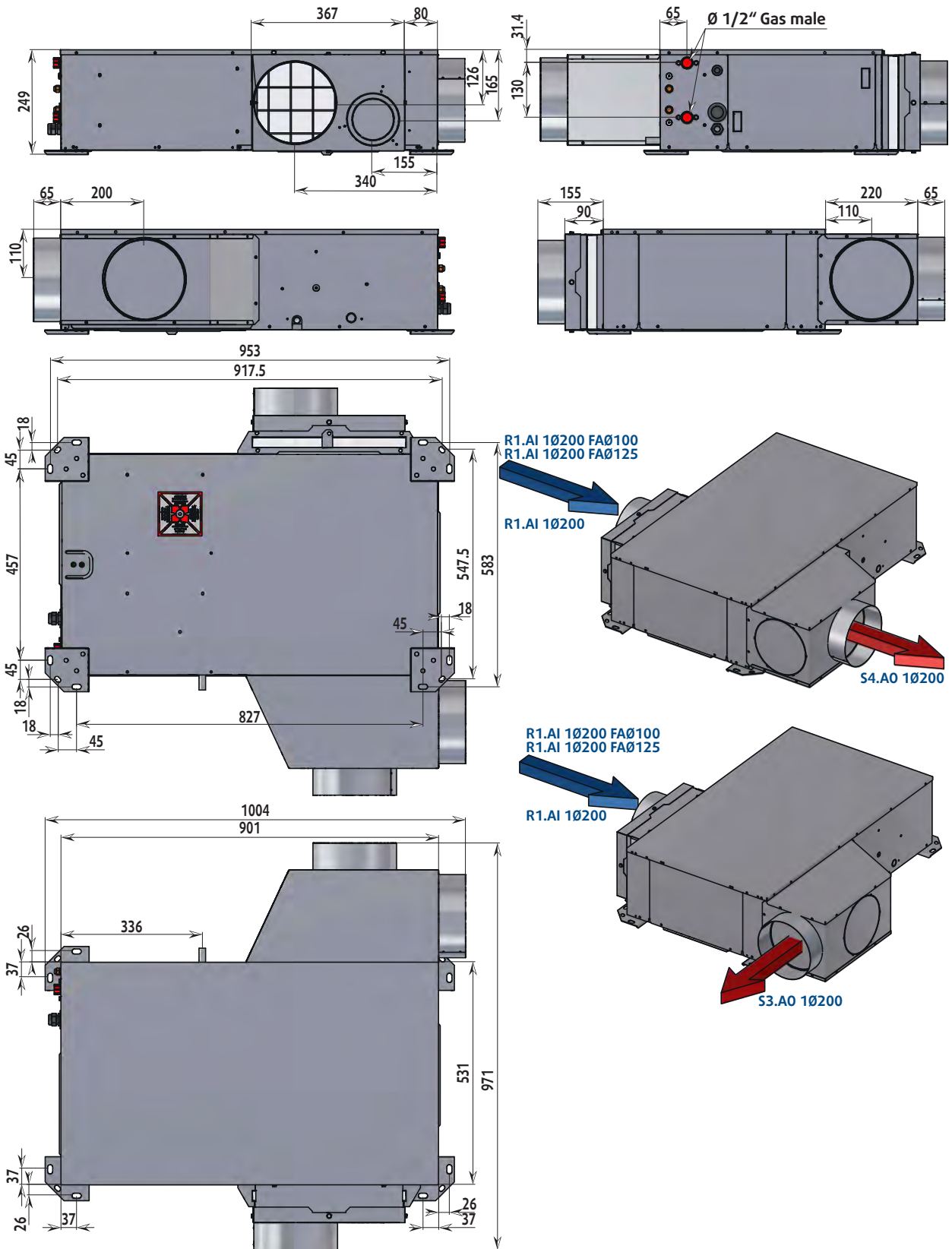

APPENDIX / ANNEXE / ANLAGE / ALLEGATO / ANEXO

CONFIGURATION R2.AI 1Ø200/S4.AO 1Ø200 OR R2.AI 1Ø200 FAØ100/S4.AO 1Ø200 OR R2.AI 1Ø200 FAØ125/S4.AO 1Ø200 OR R2.AI 1Ø200/S3.AO 1Ø200 OR R2.AI 1Ø200 FAØ100/S3.AO 1Ø200 OR R2.AI 1Ø200 FAØ125/S3.AO 1Ø200

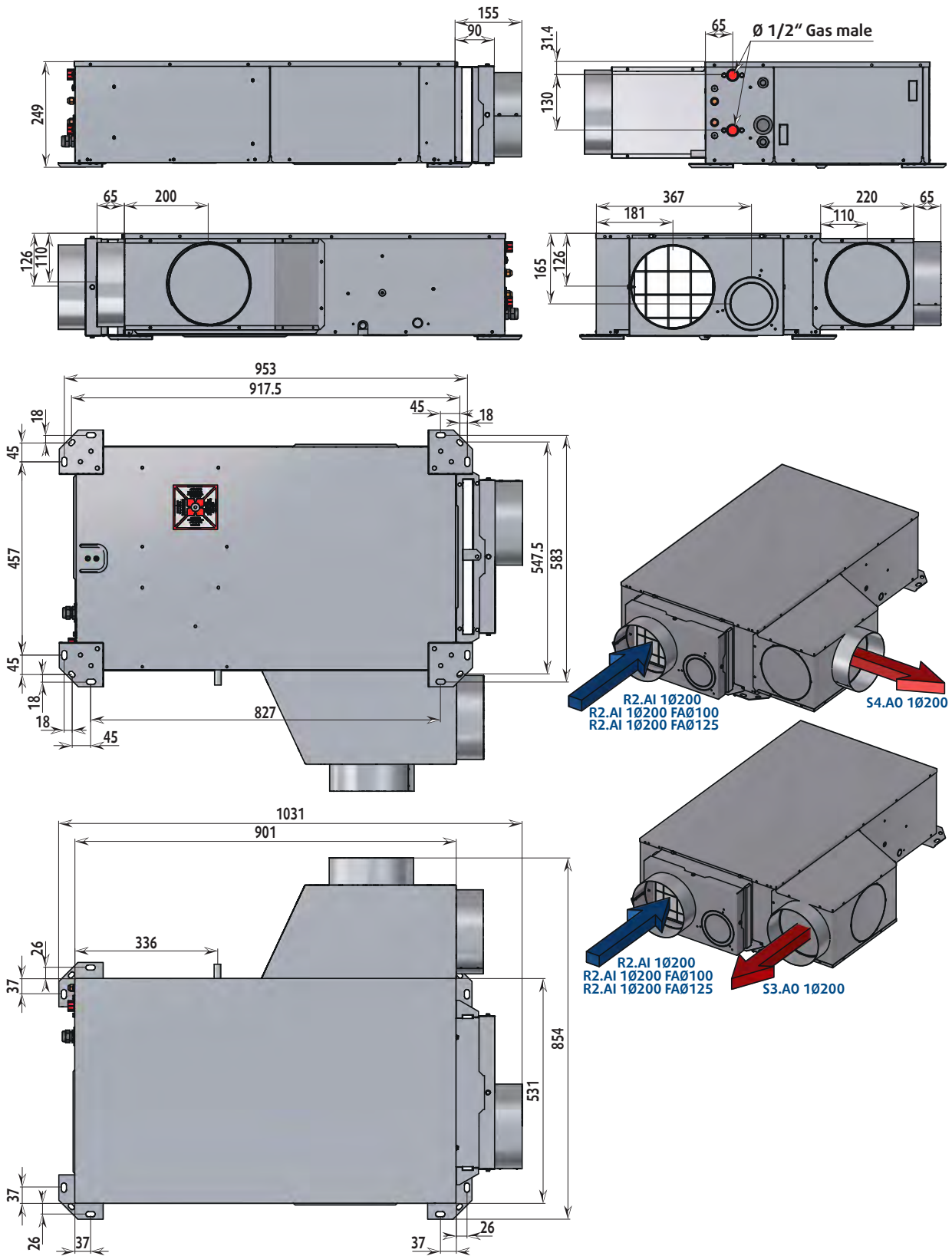

CONFIGURATION AO XLN

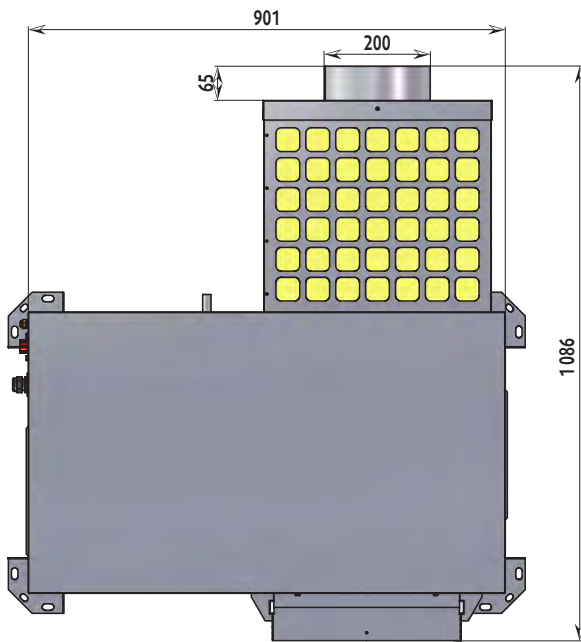

R1.AI RECT

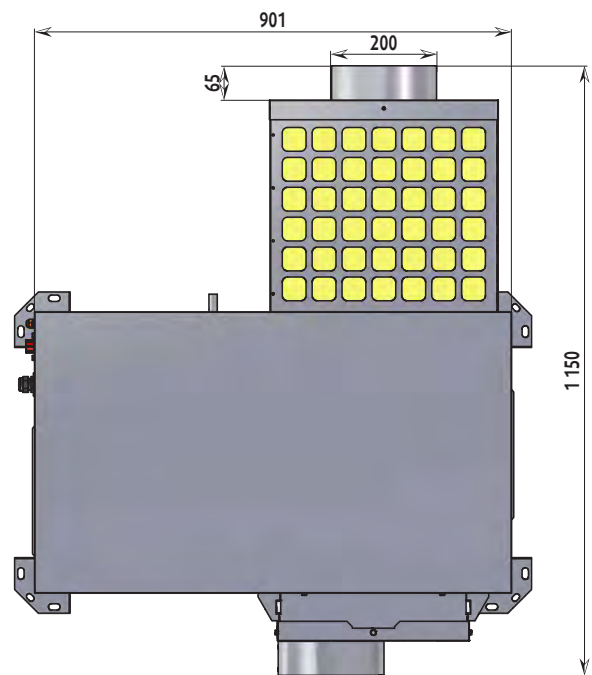

R1.AI 1Ø200

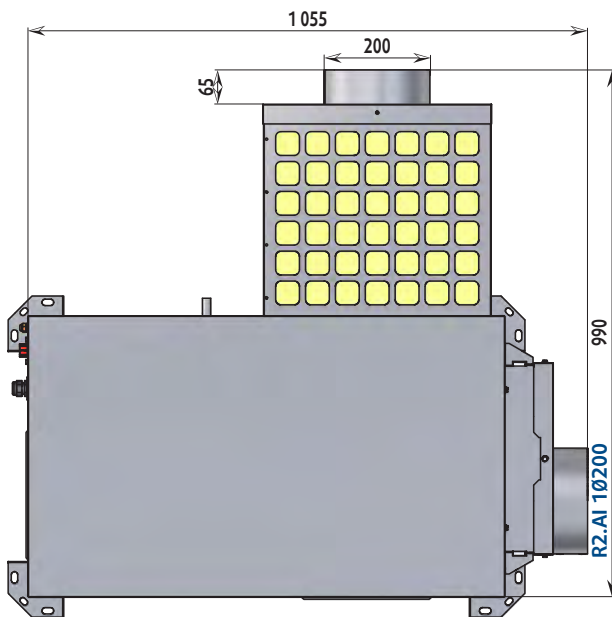

R2.AI 1Ø200

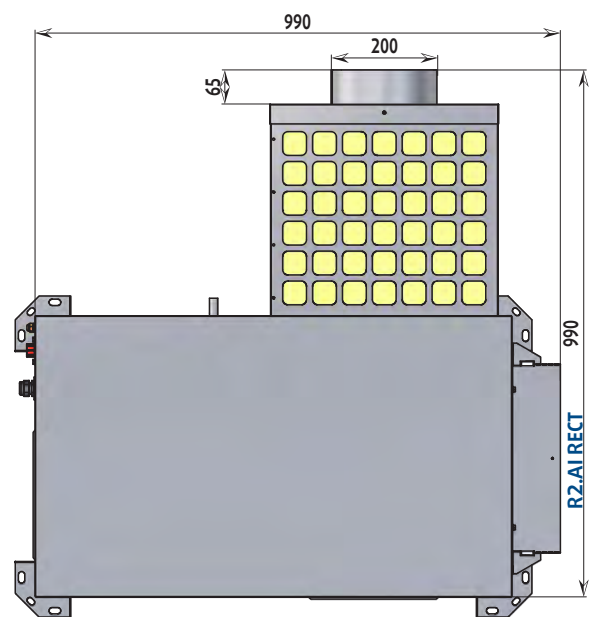

R2.AI RECT

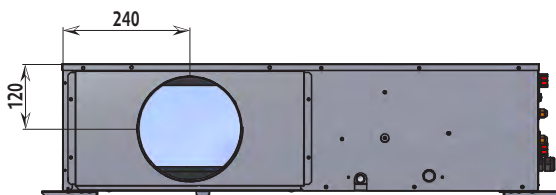

WIRING DIAGRAM SCHEMAS ELECTRIQUES STROMLAUFPLANS SCHEMA ELETRICO ESQUEMA ELECTRICO

TAKE CARE!

These wiring diagrams are correct at the time of publication. Manufacturing changes can lead to modifications. Always refer to the diagram supplied with the product.

ATTENTION

Ces schémas sont corrects au moment de la publication. Les variantes en fabrication peuvent entraîner des modifications. Reportez-vous toujours au schéma livré avec le produit.

ACHTUNG!

Diese Stromlaufplans sind zum Zeitpunkt der Veröffentlichung gültig. In Herstellung befindliche Varianten können Änderungen mit sich bringen. In jedem Fall den mit dem Produkt gelieferten Stromlaufplan hinzuziehen.

ATTENZIONE !

Questi schemi sono corretti al momento della pubblicazione. Le varianti apportate nel corso della fabbricazione possono comportare modifiche. Far sempre riferimento allo schema fornito con il prodotto.

ATENCIÓN !

Esto esquemas son correctos en el momento de la publicación. Pero las variantes en la fabricación pueden ser motivo de modificaciones. Remítase siempre al esquema entregado con el producto.

POWER SUPPLY MUST BE SWITCHED OFF BEFORE STARTING TO WORK IN THE ELECTRIC CONTROL BOXES!

MISE HORS TENSION OBLIGATOIRE AVANT TOUTE INTERVENTION DANS LES BOITIERS ELECTRIQUES.

VOR JEDEM EINGRIFF AN DEN ANSCHLUßKÄSTEN UNBEDINGT DAS GERÄT ABSCHALTEN!

PRIMA DI OGNI INTERVENTO SULLE CASSETTE ELETTRICHE ESCLUDERE TASSATIVAMENTE L'ALIMENTAZIONE !

PUESTA FUERA DE TNESIÓN OBLIGATORIA ANTES DE CUALQUIER INTERVENCIÓN EN LAS CAJAS ELÉCTRICAS!



LEGEND

	English	Français	Deutsch	Italiano	Español
	DESCRIPTION	DESIGNATION	BEZEICHNUNG	DENOMINAZIONE	DESCRIPCIÓN
FFG	Fuse terminal + Fuses (not supplied or option)	Porte-fusibles + fusibles (non fourni ou option)	Sicherungshalter + Schmelzsicherungen (nicht geliefert oder Option)	portafusibili + Fusibili (non forniti o opzione)	portafusibles + Fusibles (no incluidos u opción)
QG	Circuit breaker (not supplied or option)	Disjoncteur (non-fourni ou option)	Ofenschalter (nicht geliefert oder Option)	Interruttore forno (non fornito o opzione)	Disyuntor (no incluidos u opción)
H1	Seeing "under tension"	Voyant sous tension	sieht "unter Spannung"	Vedendo "sotto tensione"	Viendo "bajo tensión"
HD	Seeing "fault reporting"	Voyant de défaut	sieht "Fehler-Bericht"	Vedendo "rapporto di colpa"	Viendo "reportaje de defecto"
K1	Refrigeration compressor relay	Relais compresseur frigorifique	Relais der Kältemittelkompressor	Relè del compressore frigorifero	Relé de los compresor frigorífico
C1	Refrigeration compressor	Compresseur frigorifique	Kältemittelkompressor	Compressore frigorifero	Compresor frigorífico
R1	Refrigeration compressor crankcase heater	Résistance carter du compresseur	Ölumpfheizungen der Kältemittelkompressor	Resistenze del carter del compressore frigorifero	Resistencias de cárter de los compresor frigorífico
FT	External safety compressor	Sécurité externe compresseur	Extern Sicherheitsvorrichtungen von Kompressor	Sicurezza esterna del compressore	Seguridad externa del compresor
LP	Automatic reset Low Pressure pressostat	Pressostat basse pression à réarmement automatique	Niederdruckpressostat mit selbsttätiger Wiedereinschaltung	Pressostato bassa pressione con riarmo automatico	Presostato de baja presión con rearme automático
HP	Automatic reset High Pressure pressostat	Pressostat haute pression à réarmement automatique	Hochdruckpressostat mit selbsttätiger Wiedereinschaltung	Pressostato alta pressione con riarmo automatico	Presostato de alta presión con rearme automático
CC1	C1 compressor condenser (single phase models)	Condensateur du compresseur C1 (modèles monophasés)	Kondensator von Kompressor C1 (Einpfasenmodelle)	Condensatore del compressore C1 (modelli monofase)	Condensador del compresor C1 (modelos monofásicos)
RV1	4 way valve for cycle inversion	Vanne 4 voies d'inversion de cycle	4-Wege-Umkehrventil für thermodynamisches Heizen	Valvola 4 vie di inversione di ciclo	Valvula de 4 vías de inversión de ciclo
SW	Detector of condensed water level	Détecteur de niveau d'eau de condensation	Detektor des Wasserstandes der Verdampfung	Rivelatore di livello d'acqua di condensazione	Detector de nivel de agua de condensación
IF	Treated air fan motor	Moteur de ventilation air traité	Lüftermotor Zuluft	Motore di ventilazione aria trattata	Motor de ventilación aire tratado
Y1	Water circuit by-pass valve (not supplied)	Vanne by-pass circuit d'eau (non fournie)	Bypass-Ventil Wasserkreislauf (nicht geliefert)	Valvola by-pass circuito dell'acqua (non fornita)	Valvula by-pass del circuito de agua (no incluida)
FS	Flow switch (option)	Flow switch (option)	Strömungsschalter (Option)	Flussostato (opzione)	Commutador de flujo (opción)
SM1	ON/OFF switch	Interrupteur marche/arrêt	Ein / Aus - Schalter	Interruttore On/Off	Interruptor de marcha/parada
SS/W	Summer/winter switch (closed in winter) (not supplied)	Interrupteur été/hiver (fermé en hiver) (non fourni)	Winter/Sommer-Schalter (im Winter geschlossen) (nicht geliefert)	Interruttore estate/inverno (chiuso in inverno) (non fornita)	Interruptor de invierno/verano (cerrado en invierno) (no incluida)
CW	Window contact switch	Contact de fenêtre	Fensterkontakt	Contacto di finestra	Contacto de ventana
T1	Transformer 230V/24V	Transformateur 230V/24V	Transformator 230V/24V	Trasformatore 230V/24V	Transformador 230V/24V
FFT	Fuse terminal + fuse 1A	Porte-fusible + fusible 1A	Sicherungsklemme + Sicherung 1A	Portafusibile + fusibile 1A	Terminal de fusible + fusible 1A
RCX POL822	Local control module	Rappel de commande local	Fernbedienung mit Thermostat	Richiamo di comando locale	Mando secundario local
ICT	Anti-freezing protection sensor	Sonde anti-givre	Frostschutztemperaturfühler	Sonda antibirina	Sonda antiescarcha
RAT	Air temperature sensor	Sonde de température d'air	Lufttemperaturfühler	Sonda di temperatura dell'aria	Sonda de temperatura de aire
LWT	Outlet water temperature sensor	Sonde de température de sortie d'eau	Wasseraustrittstemperaturfühler	Sonda di temperatura d'uscita d'acqua	Sonda de temperatura de salida de agua

	CONDENSATE PUMP OPTION	OPTION POMPE DE RELEVAGE DES CONDENSATS	OPTION PUMP KONDENSAT	OPZIONE POMPA CONDENSATO	OPCIÓN BOMBA DE CONDENSADOS
MP	Condensate pump	Pompe de relevage condensat	Pump Kondensat	Pompa condensato	Bomba de condensados
SB2	Condensate pump fault contact	Contact de défaut de la pompe de relevage des condensats	Fehlerhafter Kontakt der Kondensatpumpe	Contacto di guasto della pompa condensato	Contacto de falla de la bomba de condensado
	FAULT REPORTING OPTION	OPTION REPORT DEFAUT	OPTION STÖRMELDUNGSÜBERTRAGUNG	OPZIONE RIPORTO DIFETTO	OPCIÓN TRANSMISION DE FALLO
KD	Remote fault reporting relay (3 A max / 230 V)	Relais de report à distance des défauts (3 A max/230V)	Relais Störmeldungs-Fernübertragung (3 A max./230V)	Relè di riporto a distanza dei difetti (3 A max/230V)	Relé de transmisión a distancia de los fallos (3 A como máximo/230 V)
	ELECTRIC HEATING BATTERY OPTION	OPTION BATTERIE ELECTRIQUE	OPTION ELEKTRISCHE BATTERIE	OPZIONE BATTERIA ELETTRICA	OPCIÓN BATERIA ELECTRICA
KC1	Stage 1 heating relay	Relais chauffage étage 1	Heizrelais Stufe 1	Relè riscaldanti stadio 1	Relé calefactores etapa 1
KC2	Stage 2 heating relay	Relais chauffage étage 2	Heizrelais Stufe 2	Relè riscaldanti stadio 2	Relé calefactores etapa 2
EH1	Stage 1 heating elements	Éléments chauffants étage 1	Heizelemente Stufe 1	Elementi riscaldanti stadio 1	Elementos calefactores etapa 1
EH2	Stage 2 heating elements	Éléments chauffants étage 2	Heizelemente Stufe 2	Elementi riscaldanti stadio 2	Elementos calefactores etapa 2
FA1/2	Automatic reset safety thermostats	Thermostats de sécurités chauffage à réarmement automatique	Sicherheitsthermostate mit selbsttätiger Wiedereinschaltung	Termostati di sicurezza con riarmo automatico	Termostatos de seguridad con rearme automático
FM1/2	Manual reset safety thermostats	Thermostats de sécurités chauffage à réarmement manuel	Sicherheitsthermostate mit Handentriegelung	Termostati di sicurezza con riarmo manuale	Termostatos de seguridad con rearme manual

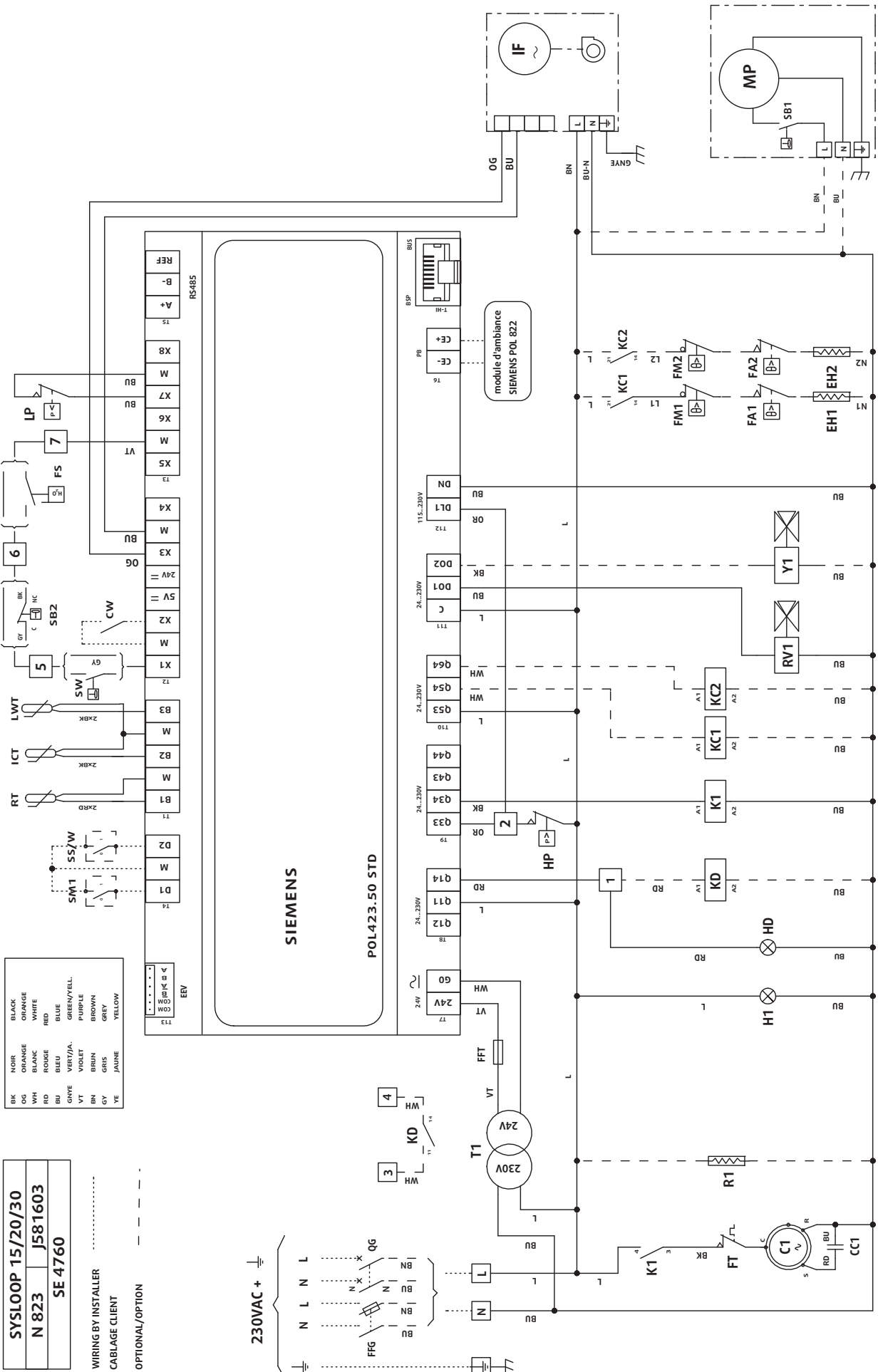

SYSLOOP 15/20/30
N 823 J581603
SE 4760

WIRING BY INSTALLER
 CABLAGE CLIENT

OPTIONAL/OPTION

As part of our ongoing product improvement programme, our products are subject to change without prior notice. Non contractual photos.

Systemair AC SAS

Route de Verneuil
27570 Tillières-sur-Avre
FRANCE

☎ : +33 (0)2 32 60 61 00

📠 : +33 (0)2 32 32 55 13



IOM SL 01-S-3GB
Part number : **J581670GB**
Supersedes : **IOM SL 01-S-2GB**