

RoofT@ir

Rooftop Units - Cooling Only and Heat Pump Versions
Models RTL/RTH 30 to 110

Scroll Compressor



Refrigerant R410A



33.0 to 108.0kW



32.0 to 106.0kW



Unit Description

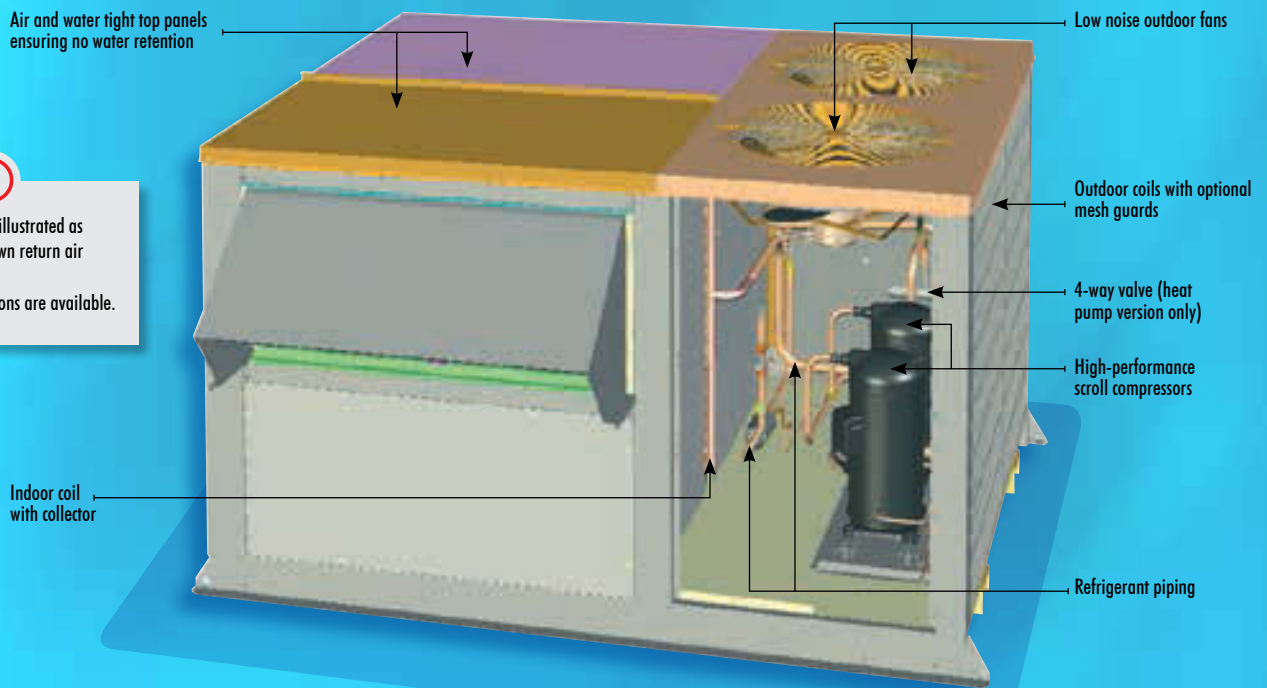
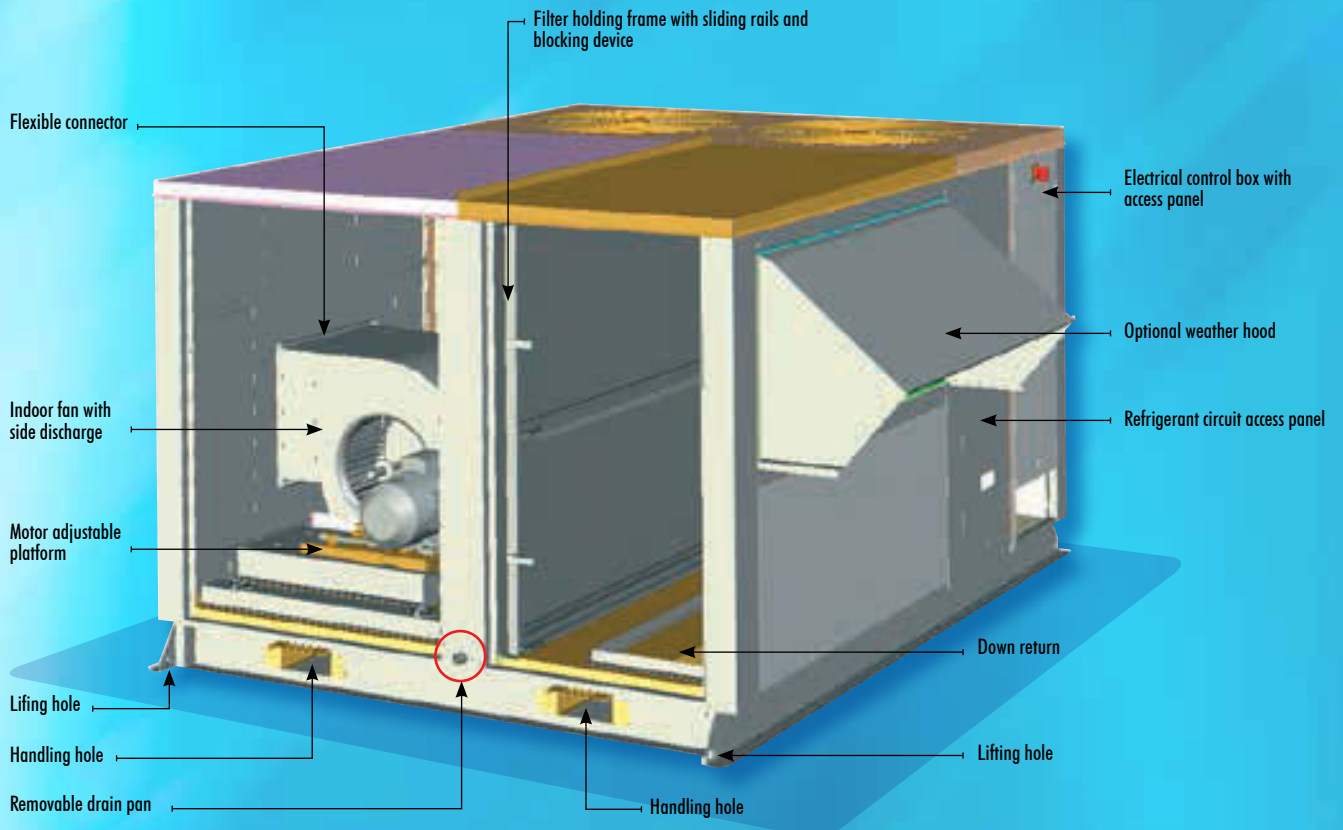

i
 This unit has been illustrated as side supply and down return air configuration. Further configurations are available.

Technical Features

General

- Assembled weatherproof single package, using R410A refrigerant to improve EER.
- Fully insulated cabinet provides the best thermal and acoustical protection.
- Cooling Only, Heat Pump with additional heating (optional) by electric heaters or hot water coil.
- A full run test is performed at the factory before shipping to ease commissioning on site.

Cabinet

- Compact, light and single piece design.
- All panels, floor and roof exposed to weather, are painted to prevent corrosion.
- No visible screws or bolts on the cabinet improve aesthetic and eliminate risk of punctuated corrosion.
- All metal-to-metal contact surfaces exposed to the weather are sealed with closed cell neoprene gaskets.
- Sloped roof to ease rain water drainage.
- Removable service panels for full unit access.
- Access panels are fastened by a quarter-turn rotor lock using a triangular handle.
- Galvanized steel single base rail ensuring high structural rigidity.
- Rigging holes and fork lift openings on the base rail to facilitate transportation and handling.
- Optional roof mounting curb, factory assembled, non adjustable or adjustable to suit roof slopes.
- Insulated with glass wool MO 62 kg/m³ – CE certified.
- Air treatment compartment with 25 mm insulation to reduce energy loss (0.035 W/m.K), thermal bridge and sound disturbance.
- Optional double wall design panels to prevent insulation fiber entering into the building and harmful build-up of bacteria or contaminants.

Technical compartments for RTL/RTH 100-110

- Weatherproof technical compartment independent from the airflow.
- Natural ventilation of the electrical board to stop overheating in summer.
- Electric cables and wires protected.

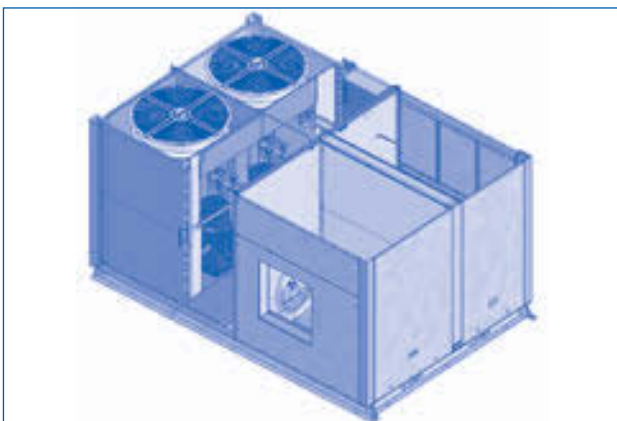

Refrigeration system

R410A benefits

- Best heat transfer.
- Environmental friendly refrigerant with zero ODP (Ozone Depleting Potential).
- Stable composition compared to R407C (2 refrigerant mixture instead of 3 with R407C).
- Temperature glide less than 0.2 K during evaporation.
- Smaller liquid line pipe.
- Lower refrigerant charge.

Refrigeration circuit

- Cooling only or heat pump version designed to satisfy comfort and commercial applications.
- Scroll compressors for higher efficiency with better resistance to liquid return and less vibration.
- Crankcase heater on each compressor to eliminate refrigerant migration and improve start up in winter.
- Tandem compressors on 1-circuit and single compressor on dual-circuits provide 2-stage cooling/heating capacity.
- Refrigerant brazing, fittings, and indoor coil headers are assembled in one technical compartment to ease service without disturbing unit operation.
- Bi-flow devices (expansion device, filter-dryer, sight glass) are used on each circuit.
- Outdoor coils designed for low air resistance to reduce axial fan power consumption and noise level.
- Hydrophilic blue fins provided on outdoor coils (heat pump version only) for better removal of water droplets on defrost cycle.
- Holes in the unit floor under the outdoor coils to drain defrost and rain water beyond the roof curb to the roof.
- Indoor coil (blue fins) allows for commercial or industrial applications with higher dehumidification rate.
- Extractible drain pan under indoor coil, to allow for hygienic cleaning

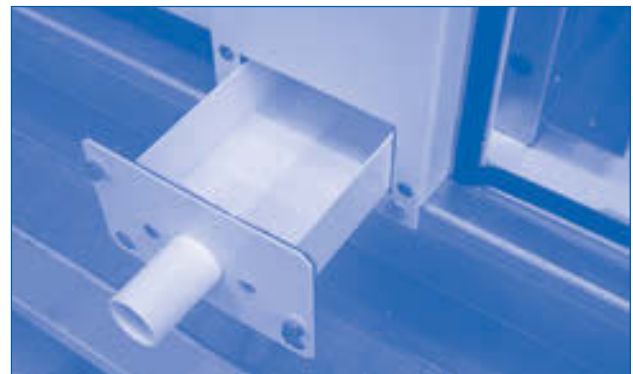

- All models receive a specific charge of R410A and are subject to a full leak test.
- Outside access to HI-LO pressure gauges, to hold unit performance while testing without opening any panels.
- Optional low ambient operation kit ensures cooling operation down to -10 °C outdoor temperature.

Technical Features (continued)

Blowers and drives

- Standard belt driven centrifugal dual inlet blower with forward curved blades.
- Optional centrifugal blower with backward curved blades for industrial applications and higher external static pressure.
- Single speed motors supplied with adjustable pulleys to fit operating conditions on site.
- Motors with permanently lubricated sleeve bearings to assure long lasting operation.
- Motor mounted on an independent platform with adjusting spanner screw to ease alignment and belt tension.
- Blower with flexible connection to eliminate vibration transfer to cabinet.
- Factory fitted airflow switch (optional) located between entry and exit of blower for correct control, wired to the controller (IATC).
- Choice of factory-fitted supply air configurations : Down (S1), Side (S2), Front (S3), Up (S4). S1 is standard; S2, S3 and S4 are optional.
- Choice of factory-fitted return air configurations : Down (R1), Side (R2), Front (R3), Up (R4). R1 is standard; R2, R3 and R4 are optional.

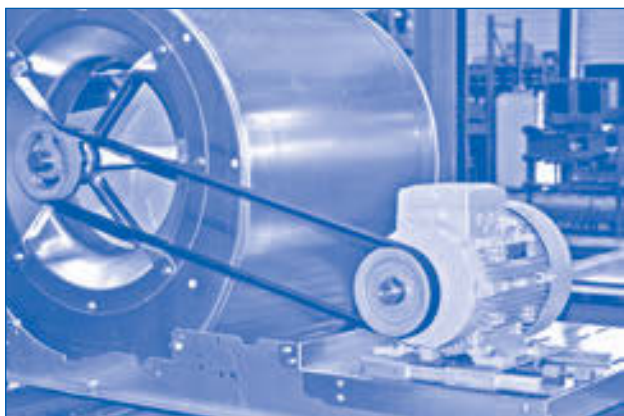

Options

Air filters

- Air filters are compliant with EN 779.
- Universal cells' dimensions.
- Mounted on sliding rail for easy service.
- 2 options of flat filters :
 - G4 filter
 - High efficiency filter G4+ F6
- Factory fitted clogged filter switch wired to the IATC (option).

2-damper economizer (R1 and R2 configurations)

- Economizer allows using the greatest obtainable quantity of outdoor air energy to minimize compressor consumption.
- Economizer is equipped with 2 counteracting dampers linked together to one proportional actuator wired to IATC.
- Adjustable minimum position of outdoor air damper to control hygienic ventilation.

- The economizer is equipped with sensors wired to the IATC. According to control type, 3 combinations of sensors are available :

1. Sensible control using temperature difference (RAT : Return Air Temperature & OAT : Outdoor Air Temperature).
2. Enthalpy control using temperature and humidity sensor to define enthalpy difference (RAH & OAH).
3. Air quality control using quality sensor (VOC type) placed on the return to ensure the necessary ventilation with more outdoor air to dilute the contaminants and improve air quality.

Down flow R1

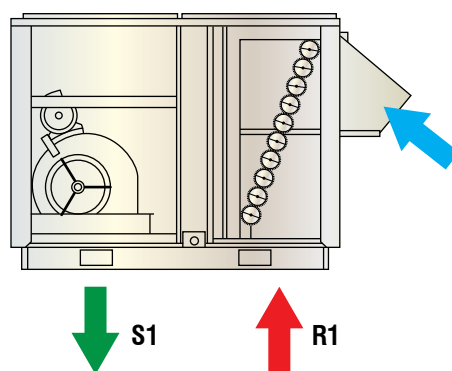

Horizontal flow R2

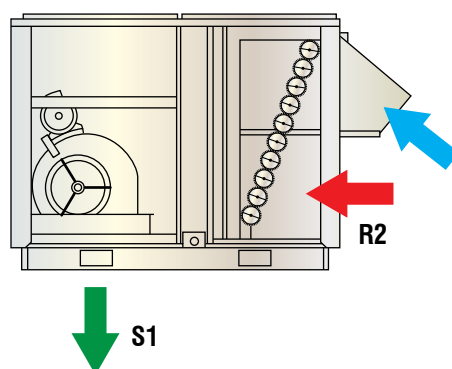

Up flow R4

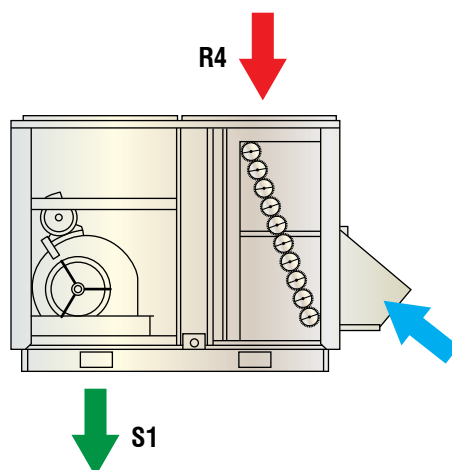

Technical Features (continued)

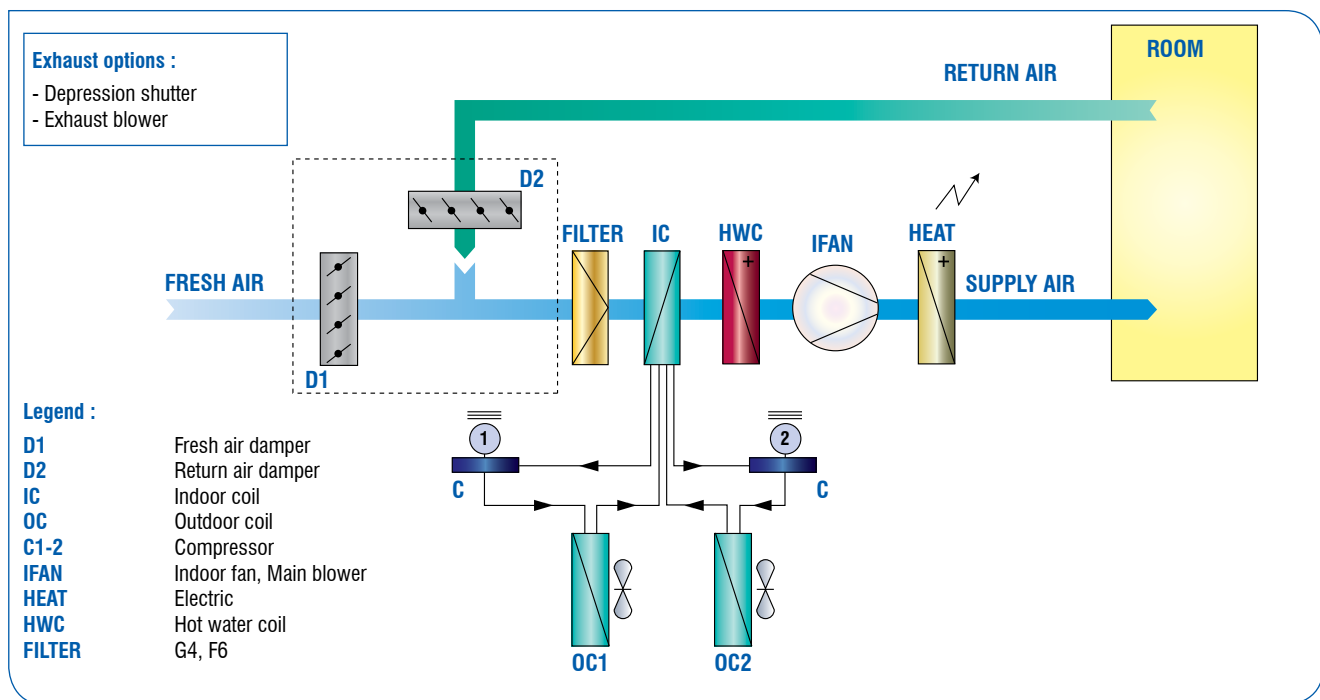

The economizer reduces the operational time of the compressors using outdoor air to satisfy the cooling or heating demand.

- Outdoor air damper closed on OFF periods.
- Outdoor air damper closed on start-up, morning warm-up and night-set-back modes for an economic operation.

The 2-damper configuration is suitable only for bottom or side or top return air configurations (R1, R2 and R4).

- A retractable rain hood with bird screen is factory-assembled.
- Moisture eliminator on fresh air is optional.

Options of exhaust air on the economizer

Depression shutter (compatible with R1 and R4 only)

- Not compatible with the exhaust blower.
- Exhaust air system with barometric damper to assist natural building depressurization when the return air damper is closed.
- One-way depression shutter closed on OFF periods to avoid outdoor air intake.
- Supplied with retractable rain hood to ease transportation.

Exhaust blower (compatible with R1 only)

- Exhaust air blower kit, for mechanical removal of used air from the building, when the ducted return air is designed at pressure drop higher than the building natural leakage rate.
- Used when economizer is fitted on the unit. Activated by the control when fresh air damper is 100% open.
- The blower exhausts up to 25% of the nominal air volume on closed return air damper.
- Installed at 90° from the outdoor air intake to avoid air short-circuiting.

Manual 25% fresh air function

- Factory fitted manual outdoor air system to ventilate the building with outdoor air up to 25% of nominal air volume.
- Not compatible with the economizer.

- Retractable rain hood to ease transportation.
- Bird screen.
- Non-return shutter closed during OFF periods, preventing infiltrations of outdoor air.
- Moisture eliminator is optional (factory-fitted or field-installed).

Hot water heating

- Hot water heater available on all air flow configurations.
- Finned coil mounted on a sliding rail and covers the entire surface of the indoor DX coil. Advantages :
 - Low air face velocity
 - Low noise level
 - Low pressure drop (approx. 10 Pa)
- Located downstream of indoor DX coil.
- Access hinged door with quarter-turn fasteners to ease service.
- 3-way valve with copper plumbing and anti-freeze thermostat fitted at the factory inside the unit.

Electric heat (S1 and S3 configurations)

- Electric heaters available on down flow (S1) or front flow (S3) supply air configuration.
- The electric heaters are made of smooth stainless steel tubes and placed in a slide drawer.
- Two capacities are available for all models, low (CH1) and high (CH2) capacity.
- Electric heaters supplied with two manual and automatic reset safety thermostats.

Technical Features (continued)

Additional options & accessories

Roof curb

- The roof mounting curb is made of galvanized steel.
- Factory assembled adjustable roof curb with return air plenum and grille to eliminate return air ducting from the building to the unit.
- Gasket is supplied with the roof curb to join the perimeter of the curb to the unit, and stop vibration and thermal bridge.
- ERP roof curb is available to be compliant with article CH40 of the French building regulation. This specific roof curb provides air circulation between unit and building according to new fire regulation. Double skin duct is insulated with 25 mm glass wool. Bottom is covered and insulated to avoid any condensation or heat loss from the building.

Antivibration mounts (AVMs)

6 anti-vibration steel-rubber supports are optional for application without roof mounting curb.

Electrical Panel & Control Features

The RTL/RTH is assembled and wired with all controls necessary to be fully tested at the factory and shipped **READY-TO-START**.

Controls are located in a watertight compartment isolated from the air stream. Internal wiring and cables are identified to ease trouble shooting. The electric is compliant to CE Standards and EN 60204-1.

A main disconnect switch is accessible from outside the RTL/RTH. The single main disconnect switch is sized at the factory for all options supplied.

A single power connection for side inlet is standard. A power supply through the bottom of the RTL/RTH is optional.

A direct digital controller programmed at the factory (the **Intelligent Air Technology Control, IATC**) manages and optimises all year-round operation with dedication to comfort and energy saving.

The IATC stages heating and cooling to desired ambient load, monitoring compressor cycling and rotation as well as defrost, protecting from overloading, high and low pressure, observing minimum ventilation requirements and blower mode, continuous or intermittent. A winter-summer ambient temperature compensation as well as min./max. ambient setting are standard.

Maintenance parameters and unit/compressors operation hours are also available.

The IATC can be supplied (option) with a day-week timer board. The scheduling is field programmed for occupied-unoccupied modes with ambient temperature set-back. The last 150 alarms are always stored. The optional board also allows to store the date and hour of each alarm appearance.

The user interface (optional) has general parameters (set points...) and password protected menus (maintenance...). It is field installed on a wall or a panel.

The user interface is provided with a 6 button key pad for field programming of set-points, proportional bands, and alarm threshold.

Smoke detector

Smoke detector is placed behind the filter and is linked to IATC board.

If alarm is detected :

- Digital output is directly transferred to IATC.
- Indoor blower will be stopped.
- Economizer will be configured (open or closed).

Low ambient kit

- Available for both versions RTL/RTH.
- Authorizes cooling operation down to -10 °C ambient air condition.
- Pressure transducer is placed on the condenser outlet and provides the real high pressure value of the unit.
- One component to control both axial fans in parallel (according to the maximum current : 8 A).

The display screen is a semi graphic LCD with 4 line 20 columns and backlight, edits actual values, set-points, hours of operation and alarms.

The user interface must be located at a maximum distance of 200 m from the RTL/RTH. According to the alarm type, each can be reset using the user interface (high pressure lockout...) alarm or directly in the unit (compressor overload...).

An SMS alarm warning option via **GSM modem** card is available.

ON/OFF and Summer/Winter digital inputs (dry contact) are available for remotely controlling the unit as well as a digital output for general alarm.

A Building Management System made by others can communicate via ModBUS with an optional **RS-485 type** card to be mounted in the IATC board. The unit parameters are then transmitted and changeable from a remote Supervision and Servicing station.

User interface

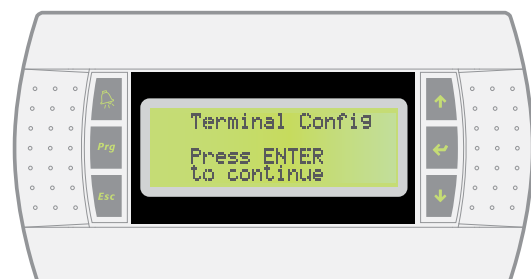

	Alarm		Up
	Prog		Enter
	Escape		Down

Electrical Panel & Control Features (continued)

User interface connection

The terminal is connected to the controller using the supplied 80 cm telephone cable between the back of the terminal and the J10 plug of the controller.

For other applications, it is possible to extend the distance between the terminal and the controller :

Up to 50 m using a 6-wire shielded telephone type cable, 2 telephone 6-pin connectors (straight pin to pin connection) and 2 ferrites mounted on the telephone cable, one on the terminal side and the other on the controller side. The shield has to be connected on the GND pin of J11.

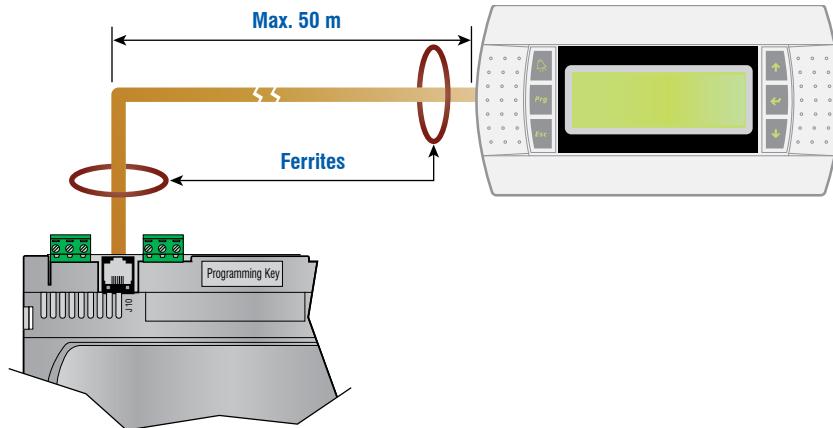

Up to 200 m, with the same shielded cable, two communication boards (optional) have to be added at controller and display sides to relay the signal.

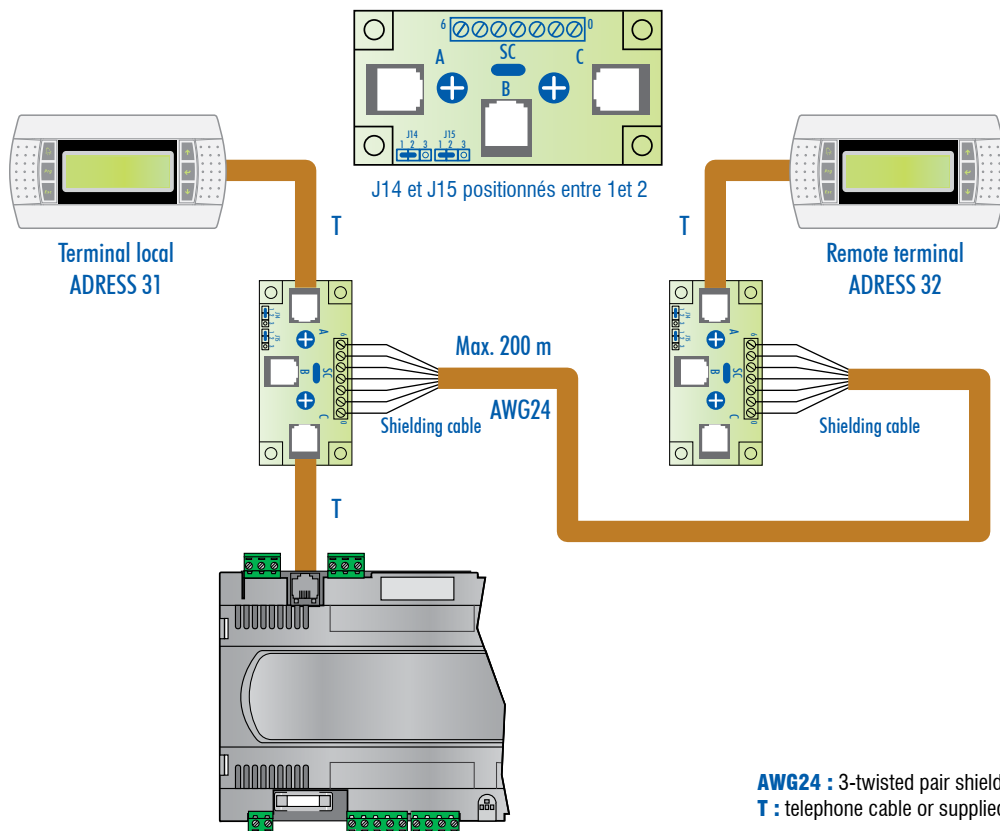

AWG24 : 3-twisted pair shielded cable
T : telephone cable or supplied cable

Electrical Panel & Control Features (continued)

Multi-rooftop installation

For several rooftop installation (in different zones/groups or not), it is possible to display each unit parameters using only one interface display for the whole installation. The principle is to connect all the units in parallel via one pLAN bus (internal protocol), while the display is connected to one master controller by using the J10 plug. This IATC will centralize certain operation modes, such as "occupied/unoccupied" mode.

In pLAN, it is possible to connect up to 31 RTL/RTH rooftops identified by their individual address, the 32nd address has to be dedicated to the display.

Connections example

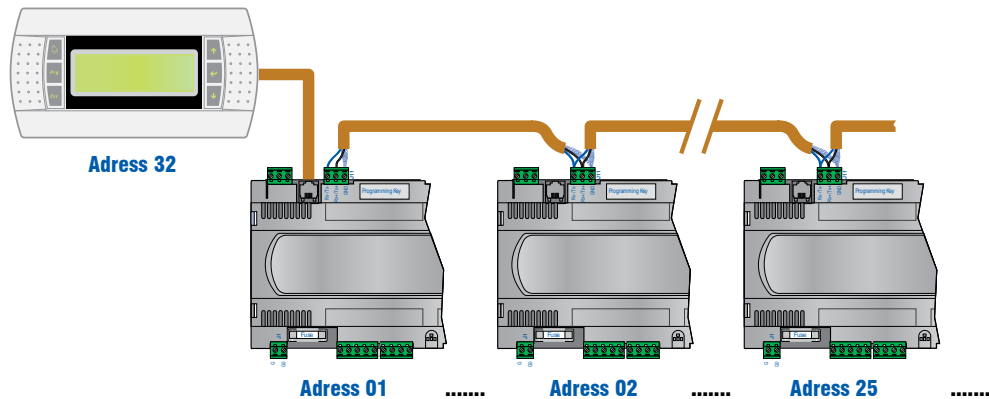

The connection between boards in pLAN is carried out using a 0.33 to 0.5 mm² (AWG20/22) shielded cable, twisted pair + shield.

Refrigerant Flow Diagrams

Sizes 30 to 50

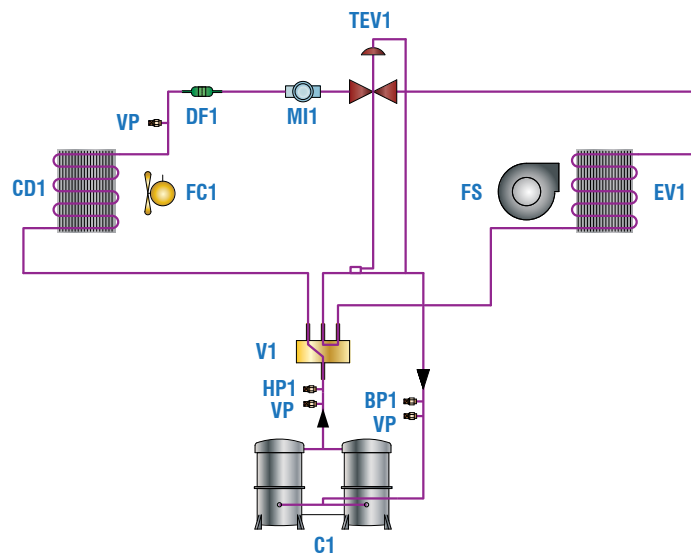

BP1	Evaporator pressure tap BP1	FS	Centrifugal fan
C1	Compressor 1	HP1	Condensing pressure tap HP1
CD1	Condenser 1	MI1	Moisture indicator 1
DF1	Drier filter 1	TEV1	Thermal expansion valve 1
EV1	Evaporator 1	V1	4-way valve cycle 1 (heat pump version only)
FC1	Propeller fan 1	VP	Pump-down tap

Refrigerant Flow Diagrams (continued)

Sizes 60 to 100

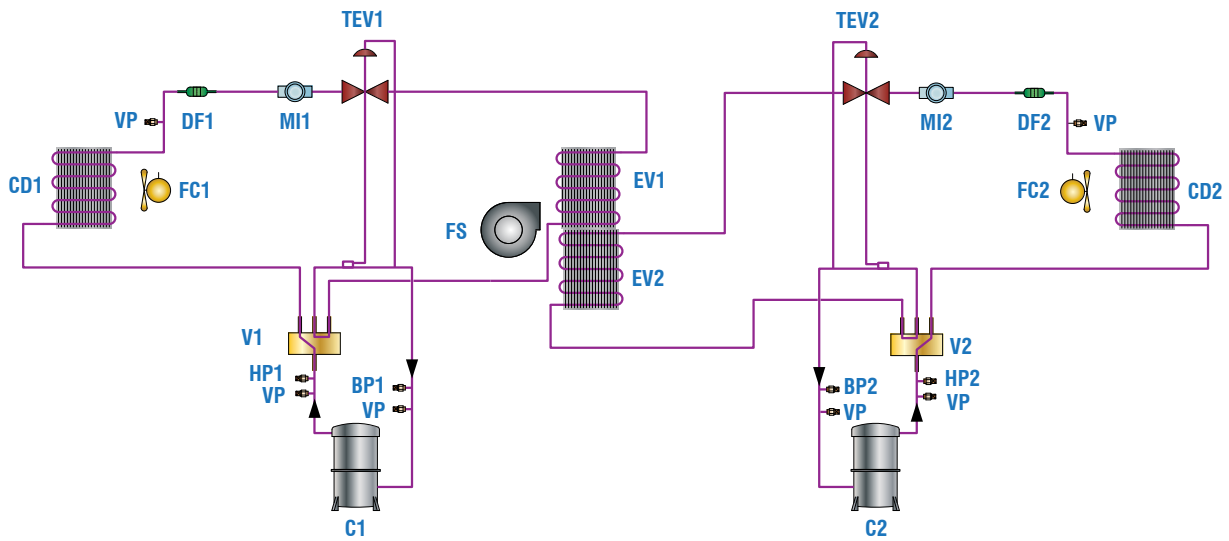

BP1	Evaporator pressure tap BP1	EV1	Evaporator 1	MI2	Moisture indicator 2
BP2	Evaporator pressure tap BP2	EV2	Evaporator 2	TEV1	Thermal expansion valve 1
C1	Compressor 1	FC1	Propellar fan 1	TEV2	Thermal expansion valve 2
C2	Compressor 2	FC2	Propellar fan 2	V1	4-way valve cycle 1 (heat pump version only)
CD1	Condenser 1	FS	Centrifugal fan	V2	4-way valve cycle 2 (heat pump version only)
CD2	Condenser 2	HP1	Condensing pressure tap HP1	VP	Pump-down tap
DF1	Drier filter 1	HP2	Condensing pressure tap HP2		
DF2	Drier filter 2	MI1	Moisture indicator 1		

Size 110

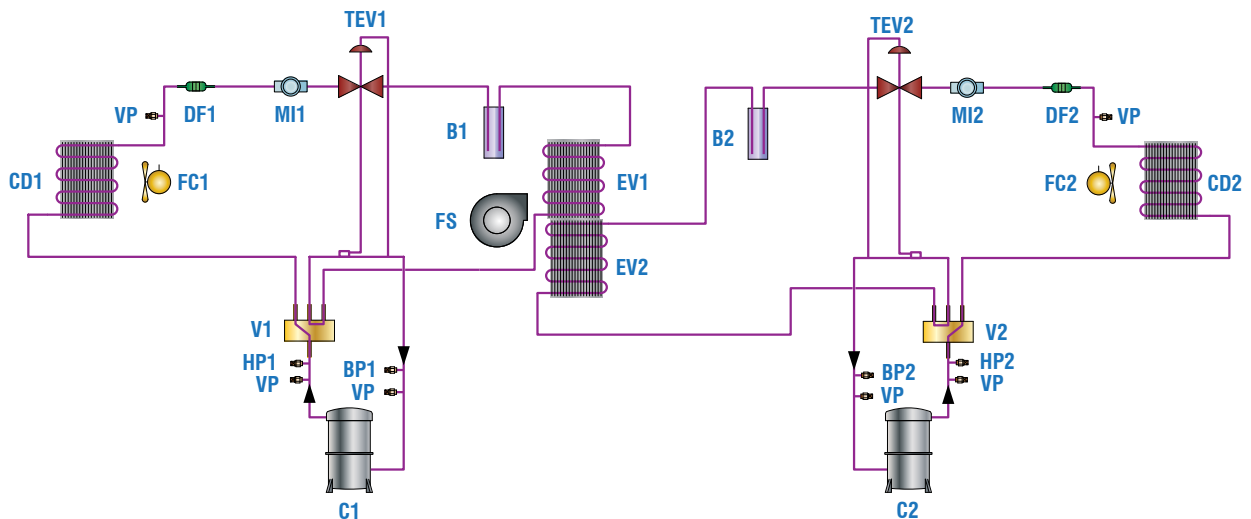

B1	Liquid tank 1	DF1	Drier filter 1	HP2	Condensing pressure tap HP2
B2	Liquid tank 2	DF2	Drier filter 2	MI1	Moisture indicator 1
BP1	Evaporator pressure tap BP1	EV1	Evaporator 1	MI2	Moisture indicator 2
BP2	Evaporator pressure tap BP2	EV2	Evaporator 2	TEV1	Thermal expansion valve 1
C1	Compressor 1	FC1	Propellar fan 1	TEV2	Thermal expansion valve 2
C2	Compressor 2	FC2	Propellar fan 2	V1	4-way valve cycle 1 (heat pump version only)
CD1	Condenser 1	FS	Centrifugal fan	V2	4-way valve cycle 2 (heat pump version only)
CD2	Condenser 2	HP1	Condensing pressure tap HP1	VP	Pump-down tap

Physical Data - RTL - Cooling Only Version

COOLING ONLY MODELS		RTL 30	RTL 40	RTL 50	RTL 60	RTL 70	RTL 80	RTL 100	RTL 110
Cooling capacity (1)	kW	32.5	41.5	50.9	59.8	67.7	84.9	96.6	108.4
Power input	kW	10.4	12.8	16	18.4	20.9	26	30.9	36.5
EER (2)		3.12	3.3	3.2	3.3	3.2	3.3	3.1	3
Power supply		400V - 3ph + N - 50Hz							
REFRIGERANT									
Type		R410A							
Number of circuits		1	1	1	2	2	2	2	2
COMPRESSORS									
Number of compressors		2	2	2	2	2	2	2	2
Assembly type		Tandem	Tandem	Tandem	Single	Single	Single	Single	Single
Capacity step	%	0-50-100	0-50-100	0-50-100	0-50-100	0-50-100	0-50-100	0-50-100	0-50-100
INDOOR COIL									
Type		Copper tubes & aluminium fins							
Number of rows		3	3	3	3	3	3	4	4
Coil face area	m ²	1.17	1.6	1.6	2	2.1	2.3	2.3	2.3
INDOOR FAN									
Type (standard)		Forward curved centrifugal							
Quantity		1	1	1	1	1	1	1	1
Air flow	m ³ /h	5 500	7 650	9 200	11 500	12 500	16 500	18 650	20 000
Nominal static pressure	Pa	250	250	250	300	300	350	350	350
Motor power	kW	1.5	1.5	2.5	5.5	5.5	7.5	7.5	7.5
Type (optional)		Back. curved	Forward curved centrifugal	Backward curved centrifugal					
Quantity		1	1	1	1	1	1	1	1
Air flow	m ³ /h	5 500	7 650	9 200	11 500	12 500	16 500	18 650	20 000
Nominal static pressure	Pa	400	400	400	450	450	500	500	500
Motor power	kW	2.2	4.0	5.5	5.5	5.5	7.5	7.5	7.5
OUTDOOR COIL									
Type		Copper tubes & aluminium fins							
Number of rows		2	2	2	2	2	2	2	2
Coil face area	m ²	1.92	3	3	4	4	4.3	6.1	6.1
OUTDOOR FANS									
Type		Propeller							
Diameter	mm	610	610	610	610	610	610	800	800
Quantity		2	2	2	4	4	4	2	2
Fan rotational speed	rpm	850	850	850	850	850	850	670	670
Nominal air flow	m ³ /h	16000	16000	16000	32000	32000	32000	34000	34000
Total motor power	kW	1.14	1.14	1.14	2.28	2.28	2.28	2	2
SYNTHETIC FLAT FILTERS (OPTIONAL)									
Number of filters		4	4	4	9	9	9	9	9
Efficiency / Filter class		> 90% / G4							
Type		Universal cells							
SYNTHETIC FLAT FILTERS (OPTIONAL)									
Number of filters		4	4	4	9	9	9	9	9
Efficiency / Filter class		> 90% / F6							
Type		Universal cells							
CASING									
Min. casing thickness	mm	1	1	1	1	1	1	1	1
Painting	type/RAL	Powder coating / 9001							
Fire resistance class		M0							
DIMENSIONS & WEIGHT									
Length	mm	2484	2484	2484	3400	3400	3400	3400	3400
Width	mm	1877	1877	1877	2227	2227	2227	2227	2227
Height	mm	1450	1450	1450	1771	1771	1771	1813	1813
Foot print	m ²	4.66	4.66	4.66	7.57	7.57	7.57	7.57	7.57
Weight (without option)	kg	600	650	700	1100	1150	1200	1300	1350

(1) Cooling capacity with Eurovent conditions : 35 °C dry bulb outdoor, 27 °C dry bulb / 19 °C wet bulb entering indoor.

(2) EER = Cooling capacity / Power input.

Operating Limits - Cooling Only

COOLING MODE	RTL 30	RTL 40	RTL 50	RTL 60	RTL 70	RTL 80	RTL 100	RTL 110
Maximum outdoor air temp.	°C	46	46	46	46	46	46	46
Minimum outdoor air temp. (4)	°C	18	18	18	18	18	18	18
Minimum indoor air temp. (5)	°C	20	20	20	20	20	20	20

(4) Fonctionnement en mode froid jusqu'à une température extérieure de -10 °C avec un kit "toutes saisons" fourni en option.

(5) With an outdoor air temperature of 18 °C.

Physical Data - RTH - Heat Pump Version

HEAT PUMP MODELS		RTH 30	RTH 40	RTH 50	RTH 60	RTH 70	RTH 80	RTH 100	RTH 110	
Cooling capacity (1)	kW	32	41	48.6	59	66	83.4	94.8	106.1	
Power input	kW	10.4	12.8	16	18.4	20.9	26	30.9	36.5	
EER - Cooling mode (2)		3.1	3.2	3	3.2	3.2	3.2	3.1	2.9	
Heating capacity (3)	kW	33.3	42.9	50.2	58.2	66.5	84	96	108	
Power input	kW	9.5	12.2	15.1	17.8	20.3	24.1	28.5	33.7	
COP - Heating mode (4)		3.5	3.5	3.3	3.3	3.3	3.5	3.4	3.2	
Power supply	400V - 3ph + N - 50Hz									
REFRIGERANT										
Type	R410A									
Number of circuits		1	1	1	2	2	2	2	2	
COMPRESSORS										
Number of compressors		2	2	2	2	2	2	2	2	
Assembly type		Tandem	Tandem	Tandem	Single	Single	Single	Single	Single	
Capacity step	%	0-50-100	0-50-100	0-50-100	0-50-100	0-50-100	0-50-100	0-50-100	0-50-100	
INDOOR COIL										
Type	Copper tubes & aluminium fins									
Number of rows		3	3	3	3	3	3	4	4	
Coil face area	m ²	1.17	1.6	1.6	2	2.1	2.3	2.3	2.3	
INDOOR FAN										
Type (standard)	Forward curved centrifugal									
Quantity		1	1	1	1	1	1	1	1	
Air flow	m ³ /h	5 500	7 650	9 200	11 500	12 500	16 500	18 650	20 000	
Nominal static pressure	Pa	250	250	250	300	300	350	350	350	
Motor power	kW	1.5	1.5	2.5	5.5	5.5	7.5	7.5	7.5	
Type (optional)	Back. curved				Forward curved centrifugal			Backward curved centrifugal		
Quantity		1	1	1	1	1	1	1	1	
Air flow	m ³ /h	5 500	7 650	9 200	11 500	12 500	16 500	18 650	20 000	
Nominal static pressure	Pa	400	400	400	450	450	500	500	500	
Motor power	kW	2.2	4	5.5	5.5	5.5	7.5	7.5	7.5	
OUTDOOR COIL										
Type	Copper tubes & aluminium fins									
Number of rows		2	2	2	2	2	2	2	2	
Coil face area	m ²	1.92	3	3	4	4	4.3	6.1	6.1	
OUTDOOR FANS										
Type	Propeller									
Diameter	mm	610	610	610	610	610	610	800	800	
Quantity		2	2	2	4	4	4	2	2	
Fan rotational speed	rpm	850	850	850	850	850	850	670	670	
Nominal air flow	m ³ /h	16000	16000	16000	32000	32000	32000	34000	34000	
Total motor power	kW	1.14	1.14	1.14	2.28	2.28	2.28	2	2	
SYNTHETIC FLAT FILTERS (OPTIONAL)										
Number of filters		4	4	4	9	9	9	9	9	
Efficiency / Filter class	> 90% / G4									
Type	Universal cells									
SYNTHETIC FLAT FILTERS (OPTIONAL)										
Number of filters		4	4	4	9	9	9	9	9	
Efficiency / Filter class	> 90% / F6									
Type	Universal cells									
CASING										
Min. casing thickness	mm	1	1	1	1	1	1	1	1	
Painting	type/RAL	Powder coating / 9001								
Fire resistance class	M0									
DIMENSIONS & WEIGHT										
Length	mm	2484	2484	2484	3400	3400	3400	3400	3400	
Width	mm	1877	1877	1877	2227	2227	2227	2227	2227	
Height	mm	1450	1450	1450	1771	1771	1771	1813	1813	
Foot print	m ²	4.66	4.66	4.66	7.57	7.57	7.57	7.57	7.57	
Weight (without option)	kg	600	650	700	1100	1150	1200	1300	1350	

- (1) Cooling capacity with Eurovent conditions : 35 °C dry bulb outdoor, 27 °C dry bulb / 19 °C wet bulb entering indoor.
 (2) EER = Cooling capacity / Effective power input.
 (3) Heating capacity with Eurovent conditions : 7 °C dry bulb / 6 °C wet bulb outdoor, 20 °C entering indoor.
 (4) COP = Heating capacity / Power input.

Operating Limits - Cooling and Heating Modes

COOLING MODE		RTH 30	RTH 40	RTH 50	RTH 60	RTH 70	RTH 80	RTH 100	RTH 110
Maximum outdoor air temp.	°C	46	46	46	46	46	46	46	46
Minimum outdoor air temp. (6)	°C	18	18	18	18	18	18	18	18
Minimum indoor air temp. (7)	°C	20	20	20	20	20	20	20	20
HEATING MODE		RTH 30	RTH 40	RTH 50	RTH 60	RTH 70	RTH 80	RTH 100	RTH 110
Maximum outdoor air temp.	°C	21	21	21	21	21	21	21	21
Minimum outdoor air temp.	°C	-10	-10	-10	-10	-10	-10	-10	-10
Minimum indoor air temp. (8)	°C	10	10	10	10	10	10	10	10

- (6) For lower outdoor air temperature (-10 °C), in cooling mode, use low ambient kit (optional).
 (7) With an outdoor air temperature of 18 °C. (8) With an outdoor air temperature of 10 °C.

Electrical Data

Unit without electric heater

RTL/RTH Models	30		40		50		60		70		80		100		110		
	PE	GE	PE	GE	PE	GE	PE	GE	PE	GE	PE	GE	PE	GE	PE	GE	
Supply voltage	400V - 3 Ph + N / 50 Hz																
Total running current	A	42	43	46	51	57	63	70	70	74	75	94	94	100	100	109	109
Maximum starting current	A	104	105	132	137	179	185	191	191	198	198	260	260	275	275	284	284
Fuse rating aM	A	50	50	50	63	63	63	80	80	80	80	100	100	100	100	125	125

Unit with electric heater CH1 (low power)

RTL/RTH Models	30		40		50		60		70		80		100		110		
	PE	GE	PE	GE	PE	GE	PE	GE	PE	GE	PE	GE	PE	GE	PE	GE	
Supply voltage	400V - 3 Ph + N / 50 Hz																
Capacity	kW	9	9	18	18	18	18	36	36	36	36	36	36	36	36	36	36
Total running current	A	58	59	77	82	88	94	123	123	127	127	157	157	163	163	172	172
Maximum starting current	A	119	121	163	168	211	217	254	254	251	251	323	323	338	338	347	347
Fuse rating aM	A	63	63	80	100	100	100	125	125	160	160	160	160	200	200	200	200

Unit with electric heater CH2 (high power)

RTL/RTH Models	30		40		50		60		70		80		100		110		
	PE	GE	PE	GE	PE	GE	PE	GE	PE	GE	PE	GE	PE	GE	PE	GE	
Supply voltage	400V - 3 Ph + N / 50 Hz																
Capacity	kW	18	18	36	36	36	36	45	45	45	45	45	45	45	45	45	45
Total running current	A	73	75	109	114	119	125	139	139	143	143	173	173	178	178	187	187
Maximum starting current	A	135	137	195	200	242	248	270	270	277	277	339	339	353	353	362	362
Fuse rating aM	A	80	80	125	125	125	125	160	160	160	160	200	200	200	200	200	200

Notes : PE : Standard ventilation - GE : High static pressure ventilation.

Important : A main fuse must mandatorily be provided on the power supply. Fuses not supplied. Cables not supplied.

Cooling Capacity Data - RTL 30 - Nominal Airflow 5500 m³/h

INDOOR COIL ENTERING AIR TEMPERATURE (°C)		OUTDOOR AIR TEMPERATURE (°C)							
		15	20	25	30	35	40	45	
Wet bulb temperature = 15 °C		Total cooling capacity (kW)	33.6	32.4	31.2	29.9	28.7	27.5	26.3
		Total power input (kW)	8.2	8.6	9.1	9.6	10.1	10.6	11.1
Dry bulb temperature	21 °C	Sensible cooling capacity (kW)	20.5	20.9	21.4	21.8	22.2	22.7	23.1
	23 °C		23.1	23.6	24.1	24.6	25.1	25.6	26.1
	25 °C		25.8	26.3	26.9	29.9	28.7	27.5	26.3
	27 °C		32.7	32.4	31.2	29.9	28.7	27.5	26.3
	29 °C		33.6	32.4	31.2	29.9	28.7	27.5	26.3
	31 °C		33.6	32.4	31.2	29.9	28.7	27.5	26.3
Wet bulb temperature = 17 °C		Total cooling capacity (kW)	35.7	34.4	33.1	31.9	30.6	29.3	28.1
		Total power input (kW)	8.2	8.7	9.2	9.7	10.2	10.7	11.2
Dry bulb temperature	21 °C	Sensible cooling capacity (kW)	19.6	20.0	20.4	20.8	21.3	21.7	22.1
	23 °C		22.4	22.9	23.4	23.8	24.3	24.8	25.3
	25 °C		25.2	25.7	26.3	26.8	27.4	27.9	28.1
	27 °C		28.0	28.6	32.4	31.9	30.6	29.3	28.1
	29 °C		34.1	34.1	33.1	31.9	30.6	29.3	28.1
	31 °C		35.4	34.4	33.1	31.9	30.6	29.3	28.1
Wet bulb temperature = 19 °C		Total cooling capacity (kW)	37.8	36.4	35.1	33.8	32.5	31.2	29.9
		Total power input (kW)	8.3	8.8	9.4	9.9	10.4	10.9	11.4
Dry bulb temperature	21 °C	Sensible cooling capacity (kW)	15.5	15.9	16.2	16.6	16.9	17.2	17.6
	23 °C		18.5	18.9	19.3	19.7	20.1	20.5	20.9
	25 °C		21.5	22.0	22.5	22.9	23.4	23.9	24.3
	27 °C		24.5	25.0	25.6	26.1	26.6	27.2	27.7
	29 °C		27.5	28.1	28.7	29.3	29.9	30.5	29.9
	31 °C		30.5	35.4	35.1	33.8	32.5	31.2	29.9
Wet bulb temperature = 21 °C		Total cooling capacity (kW)	40.0	38.6	37.2	35.8	34.5	33.1	31.7
		Total power input (kW)	8.7	9.2	9.8	10.3	10.8	11.4	11.9
Dry bulb temperature	23 °C	Sensible cooling capacity (kW)	14.1	14.4	14.7	15.0	15.3	15.6	15.9
	25 °C		17.3	17.6	18.0	18.4	18.8	19.1	19.5
	27 °C		20.4	20.9	21.3	21.8	22.2	22.6	23.1
	29 °C		23.6	24.1	24.6	25.1	25.7	26.2	26.7
	31 °C		26.8	27.4	27.9	28.5	29.1	29.7	30.3
	33 °C		29.9	30.6	31.2	31.9	32.5	33.1	31.7
Wet bulb temperature = 23 °C		Total cooling capacity (kW)	42.2	40.8	39.3	37.9	36.4	35.0	33.6
		Total power input (kW)	9.1	9.7	10.2	10.8	11.3	11.9	12.4
Dry bulb temperature	25 °C	Sensible cooling capacity (kW)	12.4	12.6	12.9	13.2	13.4	13.7	14.0
	27 °C		15.7	16.1	16.4	16.7	17.1	17.4	17.8
	29 °C		19.1	19.5	19.9	20.3	20.7	21.1	21.6
	31 °C		22.4	22.9	23.4	23.9	24.4	24.9	25.4
	33 °C		25.8	26.3	26.9	27.5	28.0	28.6	29.1

Cooling Capacity Data - RTH 30 - Nominal Airflow 5500 m³/h

INDOOR COIL ENTERING AIR TEMPERATURE (°C)		OUTDOOR AIR TEMPERATURE (°C)							
		15	20	25	30	35	40	45	
Wet bulb temperature = 15 °C		Total cooling capacity (kW)	33.1	31.9	30.7	29.5	28.3	27.1	25.9
		Total power input (kW)	8.2	8.6	9.1	9.6	10.1	10.6	11.1
Dry bulb temperature	21 °C	Sensible cooling capacity (kW)	20.2	20.6	21.0	21.5	21.9	22.3	22.8
	23 °C		22.8	23.2	23.7	24.2	24.7	25.2	25.7
	25 °C		25.4	25.9	26.5	29.5	28.3	27.1	25.9
	27 °C		32.2	31.9	30.7	29.5	28.3	27.1	25.9
	29 °C		33.1	31.9	30.7	29.5	28.3	27.1	25.9
	31 °C		33.1	31.9	30.7	29.5	28.3	27.1	25.9
Wet bulb temperature = 17 °C		Total cooling capacity (kW)	35.1	33.9	32.6	31.4	30.1	28.9	27.6
		Total power input (kW)	8.2	8.7	9.2	9.7	10.2	10.7	11.2
Dry bulb temperature	21 °C	Sensible cooling capacity (kW)	19.3	19.7	20.1	20.5	20.9	21.4	21.8
	23 °C		22.0	22.5	23.0	23.5	24.0	24.4	24.9
	25 °C		24.8	25.4	25.9	26.4	27.0	27.5	27.6
	27 °C		27.6	28.2	31.9	31.4	30.1	28.9	27.6
	29 °C		33.5	33.5	32.6	31.4	30.1	28.9	27.6
	31 °C		34.9	33.9	32.6	31.4	30.1	28.9	27.6
Wet bulb temperature = 19 °C		Total cooling capacity (kW)	37.2	35.9	34.6	33.3	32.0	30.7	29.4
		Total power input (kW)	8.3	8.8	9.4	9.9	10.4	10.9	11.4
Dry bulb temperature	21 °C	Sensible cooling capacity (kW)	15.3	15.6	16.0	16.3	16.6	17.0	17.3
	23 °C		18.2	18.6	19.0	19.4	19.8	20.2	20.6
	25 °C		21.2	21.6	22.1	22.6	23.0	23.5	24.0
	27 °C		24.1	24.7	25.2	25.7	26.2	26.8	27.3
	29 °C		27.1	27.7	28.3	28.8	29.4	30.0	29.4
	31 °C		30.0	34.9	34.6	33.3	32.0	30.7	29.4
Wet bulb temperature = 21 °C		Total cooling capacity (kW)	39.4	38.0	36.7	35.3	33.9	32.6	31.2
		Total power input (kW)	8.7	9.2	9.8	10.3	10.8	11.4	11.9
Dry bulb temperature	23 °C	Sensible cooling capacity (kW)	13.9	14.2	14.5	14.8	15.1	15.4	15.7
	25 °C		17.0	17.4	17.7	18.1	18.5	18.8	19.2
	27 °C		20.1	20.6	21.0	21.4	21.9	22.3	22.7
	29 °C		23.2	23.7	24.2	24.8	25.3	25.8	26.3
	31 °C		26.4	26.9	27.5	28.1	28.6	29.2	29.8
	33 °C		29.5	30.1	30.8	31.4	32.0	32.6	31.2
Wet bulb temperature = 23 °C		Total cooling capacity (kW)	41.6	40.2	38.7	37.3	35.9	34.5	33.0
		Total power input (kW)	9.1	9.7	10.2	10.8	11.3	11.9	12.4
Dry bulb temperature	25 °C	Sensible cooling capacity (kW)	12.2	12.4	12.7	13.0	13.2	13.5	13.8
	27 °C		15.5	15.8	16.2	16.5	16.8	17.2	17.5
	29 °C		18.8	19.2	19.6	20.0	20.4	20.8	21.2
	31 °C		22.1	22.6	23.0	23.5	24.0	24.5	25.0
	33 °C		25.4	25.9	26.5	27.0	27.6	28.1	28.7

Heating Capacity Data - RTH 30

OUTDOOR AIR TEMPERATURE (°C)		INDOOR COIL ENTERING AIR TEMPERATURE (°C)							
		18		20		22		24	
Dry bulb temperature	Wet bulb temperature	Total heating capacity (kW)	Total power input (kW)	Total heating capacity (kW)	Total power input (kW)	Total heating capacity (kW)	Total power input (kW)	Total heating capacity (kW)	Total power input (kW)
-10	-11	21.6	6.7	21.2	6.9	20.6	7.1	19.8	7.2
-9	-10	22.0	6.9	21.5	7.0	20.9	7.2	20.2	7.3
-8	-9	22.4	7.0	22.0	7.2	21.4	7.3	20.6	7.4
-7	-8	22.9	7.1	22.4	7.3	21.8	7.4	21.0	7.5
-6	-7	23.4	7.2	22.9	7.4	22.3	7.5	21.5	7.7
-5	-6	23.9	7.4	23.5	7.5	22.8	7.7	22.0	7.8
-4	-5	24.5	7.5	24.0	7.7	23.4	7.8	22.6	7.9
-3	-4	25.2	7.7	24.7	7.8	24.0	7.9	23.2	8.1
-2	-3	25.8	7.8	25.3	7.9	24.6	8.1	23.8	8.2
-1	-2	26.5	7.9	26.0	8.1	25.3	8.2	24.5	8.4
0	-1	27.3	8.1	26.8	8.2	26.1	8.4	25.2	8.5
1	0	28.1	8.2	27.5	8.4	26.8	8.5	25.9	8.7
2	1	28.9	8.4	28.4	8.6	27.6	8.7	26.7	8.8
3	2	29.8	8.6	29.2	8.7	28.5	8.9	27.5	9.0
4	3	30.7	8.7	30.1	8.9	29.3	9.1	28.3	9.2
5	4	31.7	8.9	31.1	9.1	30.3	9.2	29.2	9.4
6	5	32.7	9.1	32.1	9.3	31.2	9.4	30.2	9.5
7	6	33.8	9.2	33.3	9.5	32.2	9.6	31.1	9.7
8	7	34.9	9.4	34.2	9.6	33.3	9.8	32.1	9.9
9	8	36.0	9.6	35.3	9.8	34.3	10.0	33.1	10.1
10	9	37.2	9.8	36.4	10.0	35.4	10.2	34.2	10.3
11	10	38.4	10.0	37.6	10.2	36.6	10.4	35.3	10.5
12	11	39.6	10.1	38.9	10.4	37.8	10.6	36.5	10.7
13	12	40.9	10.3	40.1	10.6	39.0	10.8	37.6	10.9
14	13	42.3	10.5	41.4	10.9	40.3	11.1	38.9	11.2
15	14	43.7	10.7	42.8	11.1	41.6	11.3	40.1	11.4
16	15	45.1	10.9	44.2	11.3	43.0	11.5	41.4	11.6
17	16	46.6	11.1	45.6	11.5	44.4	11.8	42.7	11.9
18	17	48.1	11.4	47.1	11.8	45.8	12.0	44.1	12.1
19	18	49.6	11.6	48.6	12.0	47.2	12.3	45.5	12.3
20	19	51.2	11.8	50.2	12.3	48.8	12.5	46.9	12.6

Cooling Capacity Data - RTL 40 - Nominal Airflow 7650 m³/h

INDOOR COIL ENTERING AIR TEMPERATURE (°C)		OUTDOOR AIR TEMPERATURE (°C)						
		20	25	30	35	40	45	
Wet bulb temperature = 15 °C		Total cooling capacity (kW)	41.3	39.8	38.2	36.7	35.1	33.6
		Total power input (kW)	10.6	11.3	11.9	12.5	13.1	13.7
Dry bulb temperature	21 °C	Sensible cooling capacity (kW)	27.7	28.3	28.9	29.5	30.0	30.6
	23 °C		31.1	31.8	32.5	33.1	33.8	33.6
	25 °C		34.6	39.6	38.2	36.7	35.1	33.6
	27 °C		41.3	39.8	38.2	36.7	35.1	33.6
	29 °C		41.3	39.8	38.2	36.7	35.1	33.6
	31 °C		41.3	39.8	38.2	36.7	35.1	33.6
Wet bulb temperature = 17 °C		Total cooling capacity (kW)	43.9	42.3	40.7	39.1	37.5	35.8
		Total power input (kW)	10.7	11.4	12.0	12.6	13.2	13.8
Dry bulb temperature	21 °C	Sensible cooling capacity (kW)	26.7	27.2	27.8	28.4	29.0	29.5
	23 °C		30.4	31.0	31.6	32.3	32.9	33.6
	25 °C		34.0	34.8	35.5	36.2	36.9	35.5
	27 °C		41.8	41.3	40.7	39.1	37.5	35.8
	29 °C		43.5	42.3	40.7	39.1	37.5	35.8
	31 °C		43.9	42.3	40.7	39.1	37.5	35.8
Wet bulb temperature = 19 °C		Total cooling capacity (kW)	46.5	44.9	43.2	41.5	39.8	38.1
		Total power input (kW)	10.9	11.5	12.2	12.8	13.4	14.1
Dry bulb temperature	21 °C	Sensible cooling capacity (kW)	21.5	21.9	22.4	22.8	23.3	23.7
	23 °C		25.4	25.9	26.4	27.0	27.5	28.1
	25 °C		29.3	29.9	30.5	31.1	31.7	32.4
	27 °C		33.2	33.9	34.6	35.3	36.0	36.7
	29 °C		37.1	37.8	38.6	39.4	39.8	38.1
	31 °C		45.2	44.8	43.2	41.5	39.8	38.1
Wet bulb temperature = 21 °C		Total cooling capacity (kW)	49.3	47.5	45.8	44.0	42.2	40.5
		Total power input (kW)	11.4	12.0	12.7	13.3	14.0	14.7
Dry bulb temperature	23 °C	Sensible cooling capacity (kW)	19.6	20.0	20.4	20.8	21.3	21.7
	25 °C		23.7	24.2	24.7	25.2	25.7	26.3
	27 °C		27.9	28.5	29.1	29.6	30.2	30.8
	29 °C		32.0	32.7	33.4	34.0	34.7	35.4
	31 °C		36.1	36.9	37.7	38.4	39.2	40.0
	33 °C		40.3	41.1	45.9	45.0	43.8	42.4
Wet bulb temperature = 23 °C		Total cooling capacity (kW)	52.1	50.2	48.4	46.5	44.7	42.8
		Total power input (kW)	11.9	12.6	13.3	13.9	14.6	15.3
Dry bulb temperature	25 °C	Sensible cooling capacity (kW)	17.4	17.7	18.1	18.5	18.9	19.2
	27 °C		21.8	22.2	22.7	23.1	23.6	24.1
	29 °C		26.1	26.7	27.2	27.8	28.4	28.9
	31 °C		30.5	31.2	31.8	32.5	33.1	33.7
	33 °C		34.9	35.6	36.4	37.1	37.8	38.6

Cooling Capacity Data - RTH 40 - Nominal Airflow 7650 m³/h

INDOOR COIL ENTERING AIR TEMPERATURE (°C)		OUTDOOR AIR TEMPERATURE (°C)						
		20	25	30	35	40	45	
Wet bulb temperature = 15 °C		Total cooling capacity (kW)	40.8	39.3	37.8	36.2	34.7	33.2
		Total power input (kW)	10.6	11.3	11.9	12.5	13.1	13.7
Dry bulb temperature	21 °C	Sensible cooling capacity (kW)	27.4	27.9	28.5	29.1	29.7	30.3
	23 °C		30.8	31.4	32.1	32.7	33.4	33.2
	25 °C		34.2	39.1	37.8	36.2	34.7	33.2
	27 °C		40.8	39.3	37.8	36.2	34.7	33.2
	29 °C		40.8	39.3	37.8	36.2	34.7	33.2
	31 °C		40.8	39.3	37.8	36.2	34.7	33.2
Wet bulb temperature = 17 °C		Total cooling capacity (kW)	43.4	41.8	40.2	38.6	37.0	35.4
		Total power input (kW)	10.7	11.4	12.0	12.6	13.2	13.8
Dry bulb temperature	21 °C	Sensible cooling capacity (kW)	26.4	26.9	27.5	28.0	28.6	29.2
	23 °C		30.0	30.6	31.3	31.9	32.5	33.2
	25 °C		33.6	34.3	35.0	35.8	36.5	35.0
	27 °C		41.3	40.8	40.2	38.6	37.0	35.4
	29 °C		43.0	41.8	40.2	38.6	37.0	35.4
	31 °C		43.4	41.8	40.2	38.6	37.0	35.4
Wet bulb temperature = 19 °C		Total cooling capacity (kW)	46.0	44.3	42.7	41.0	39.3	37.7
		Total power input (kW)	10.9	11.5	12.2	12.8	13.4	14.1
Dry bulb temperature	21 °C	Sensible cooling capacity (kW)	21.2	21.6	22.1	22.6	23.0	23.5
	23 °C		25.1	25.6	26.1	26.7	27.2	27.7
	25 °C		28.9	29.5	30.1	30.8	31.4	32.0
	27 °C		32.8	33.5	34.2	34.9	35.5	36.2
	29 °C		36.6	37.4	38.2	39.0	39.3	37.7
	31 °C		44.7	44.3	42.7	41.0	39.3	37.7
Wet bulb temperature = 21 °C		Total cooling capacity (kW)	48.7	47.0	45.2	43.5	41.7	40.0
		Total power input (kW)	11.4	12.0	12.7	13.3	14.0	14.7
Dry bulb temperature	23 °C	Sensible cooling capacity (kW)	19.4	19.8	20.2	20.6	21.0	21.4
	25 °C		23.4	23.9	24.4	24.9	25.4	25.9
	27 °C		27.5	28.1	28.7	29.3	29.9	30.5
	29 °C		31.6	32.3	33.0	33.6	34.3	35.0
	31 °C		35.7	36.5	37.2	38.0	38.7	39.5
	33 °C		39.8	40.6	45.3	44.4	43.3	41.9
Wet bulb temperature = 23 °C		Total cooling capacity (kW)	51.5	49.6	47.8	46.0	44.2	42.3
		Total power input (kW)	11.9	12.6	13.3	13.9	14.6	15.3
Dry bulb temperature	25 °C	Sensible cooling capacity (kW)	17.2	17.5	17.9	18.3	18.6	19.0
	27 °C		21.5	21.9	22.4	22.9	23.3	23.8
	29 °C		25.8	26.4	26.9	27.5	28.0	28.6
	31 °C		30.1	30.8	31.4	32.1	32.7	33.3
	33 °C		34.5	35.2	35.9	36.7	37.4	38.1

Heating Capacity Data - RTH 40

OUTDOOR AIR TEMPERATURE (°C)		INDOOR COIL ENTERING AIR TEMPERATURE (°C)							
		18		20		22		24	
Dry bulb temperature	Wet bulb temperature	Total heating capacity (kW)	Total power input (kW)	Total heating capacity (kW)	Total power input (kW)	Total heating capacity (kW)	Total power input (kW)	Total heating capacity (kW)	Total power input (kW)
-7	-8	29.5	9.1	28.9	9.4	28.1	9.5	27.1	9.7
-6	-7	30.1	9.3	29.5	9.5	28.7	9.7	27.7	9.8
-5	-6	30.8	9.5	30.2	9.7	29.4	9.9	28.4	10.0
-4	-5	31.6	9.6	31.0	9.8	30.1	10.0	29.1	10.2
-3	-4	32.4	9.8	31.8	10.0	30.9	10.2	29.8	10.4
-2	-3	33.3	10.0	32.6	10.2	31.7	10.4	30.7	10.6
-1	-2	34.2	10.2	33.5	10.4	32.6	10.6	31.5	10.7
0	-1	35.2	10.4	34.5	10.6	33.6	10.8	32.4	10.9
1	0	36.2	10.6	35.5	10.8	34.5	11.0	33.4	11.1
2	1	37.3	10.8	36.6	11.0	35.6	11.2	34.4	11.4
3	2	38.4	11.0	37.7	11.2	36.7	11.4	35.4	11.6
4	3	39.6	11.2	38.8	11.4	37.8	11.6	36.5	11.8
5	4	40.9	11.4	40.1	11.7	39.0	11.9	37.7	12.0
6	5	42.2	11.6	41.3	11.9	40.2	12.1	38.8	12.3
7	6	43.5	11.9	42.9	12.2	41.5	12.3	40.1	12.5
8	7	44.9	12.1	44.0	12.4	42.8	12.6	41.4	12.7
9	8	46.4	12.3	45.5	12.6	44.2	12.8	42.7	13.0
10	9	47.9	12.5	46.9	12.9	45.7	13.1	44.1	13.3
11	10	49.4	12.8	48.5	13.1	47.2	13.4	45.5	13.5
12	11	51.1	13.0	50.1	13.4	48.7	13.6	47.0	13.8
13	12	52.7	13.3	51.7	13.7	50.3	13.9	48.5	14.1
14	13	54.5	13.5	53.4	13.9	51.9	14.2	50.1	14.3
15	14	56.3	13.8	55.1	14.2	53.6	14.5	51.7	14.6
16	15	58.1	14.0	56.9	14.5	55.3	14.8	53.3	14.9
17	16	60.0	14.3	58.8	14.8	57.1	15.1	55.1	15.2
18	17	61.9	14.6	60.7	15.1	59.0	15.4	56.8	15.5
19	18	63.9	14.9	62.6	15.4	60.9	15.7	58.6	15.8
20	19	66.0	15.1	64.6	15.7	62.8	16.1	60.5	16.1

Cooling Capacity Data - RTL 50 - Nominal Airflow 9200 m³/h

INDOOR COIL ENTERING AIR TEMPERATURE (°C)		OUTDOOR AIR TEMPERATURE (°C)						
		20	25	30	35	40	45	
Wet bulb temperature = 15 °C		Total cooling capacity (kW)	50.7	48.8	46.9	45.0	43.1	41.2
		Total power input (kW)	13.3	14.1	14.8	15.6	16.3	17.1
Dry bulb temperature	21 °C	Sensible cooling capacity (kW)	34.0	34.7	35.4	36.1	36.9	37.6
	23 °C		38.2	39.0	39.8	40.6	41.4	41.2
	25 °C		42.4	48.6	46.9	45.0	43.1	41.2
	27 °C		50.7	48.8	46.9	45.0	43.1	41.2
	29 °C		50.7	48.8	46.9	45.0	43.1	41.2
	31 °C		50.7	48.8	46.9	45.0	43.1	41.2
Wet bulb temperature = 17 °C		Total cooling capacity (kW)	53.9	51.9	49.9	47.9	45.9	44.0
		Total power input (kW)	13.4	14.2	15.0	15.7	16.5	17.3
Dry bulb temperature	21 °C	Sensible cooling capacity (kW)	32.7	33.4	34.1	34.8	35.5	36.2
	23 °C		37.2	38.0	38.8	39.6	40.4	41.2
	25 °C		41.7	42.6	43.5	44.4	45.3	43.5
	27 °C		51.2	50.7	49.9	47.9	45.9	44.0
	29 °C		53.3	51.9	49.9	47.9	45.9	44.0
	31 °C		53.9	51.9	49.9	47.9	45.9	44.0
Wet bulb temperature = 19 °C		Total cooling capacity (kW)	57.1	55.0	53.0	50.9	48.8	46.8
		Total power input (kW)	13.6	14.4	15.2	16.0	16.8	17.6
Dry bulb temperature	21 °C	Sensible cooling capacity (kW)	26.3	26.9	27.4	28.0	28.6	29.1
	23 °C		31.1	31.8	32.4	33.1	33.7	34.4
	25 °C		35.9	36.6	37.4	38.2	38.9	39.7
	27 °C		40.7	41.5	42.4	43.3	44.1	45.0
	29 °C		45.5	46.4	47.4	48.4	48.8	46.8
	31 °C		55.5	55.0	53.0	50.9	48.8	46.8
Wet bulb temperature = 21 °C		Total cooling capacity (kW)	60.5	58.3	56.1	54.0	51.8	49.7
		Total power input (kW)	14.2	15.0	15.8	16.7	17.5	18.3
Dry bulb temperature	23 °C	Sensible cooling capacity (kW)	24.0	24.5	25.1	25.6	26.1	26.6
	25 °C		29.1	29.7	30.3	31.0	31.6	32.2
	27 °C		34.2	34.9	35.6	36.4	37.1	37.8
	29 °C		39.3	40.1	40.9	41.8	42.6	43.4
	31 °C		44.3	45.3	46.2	47.2	48.1	49.0
	33 °C		49.4	50.5	56.3	55.2	53.7	52.0
Wet bulb temperature = 23 °C		Total cooling capacity (kW)	63.9	61.6	59.3	57.1	54.8	52.6
		Total power input (kW)	14.9	15.7	16.6	17.4	18.3	19.1
Dry bulb temperature	25 °C	Sensible cooling capacity (kW)	21.3	21.8	22.2	22.7	23.1	23.6
	27 °C		26.7	27.2	27.8	28.4	29.0	29.5
	29 °C		32.0	32.7	33.4	34.1	34.8	35.5
	31 °C		37.4	38.2	39.0	39.8	40.6	41.4
	33 °C		42.8	43.7	44.6	45.5	46.4	47.3

Cooling Capacity Data - RTH 50 - Nominal Airflow 9200 m³/h

INDOOR COIL ENTERING AIR TEMPERATURE (°C)			OUTDOOR AIR TEMPERATURE (°C)					
			20	25	30	35	40	45
Wet bulb temperature = 15 °C		Total cooling capacity (kW)	48.4	46.6	44.8	43.0	41.1	39.3
		Total power input (kW)	13.4	14.2	14.9	15.7	16.4	17.2
Dry bulb temperature	21 °C	Sensible cooling capacity (kW)	32.4	33.1	33.8	34.5	35.2	35.9
	23 °C		36.5	37.2	38.0	38.8	39.6	39.3
	25 °C		40.5	46.4	44.8	43.0	41.1	39.3
	27 °C		48.4	46.6	44.8	43.0	41.1	39.3
	29 °C		48.4	46.6	44.8	43.0	41.1	39.3
	31 °C		48.4	46.6	44.8	43.0	41.1	39.3
Wet bulb temperature = 17 °C		Total cooling capacity (kW)	51.5	49.6	47.7	45.8	43.9	42.0
		Total power input (kW)	13.5	14.3	15.1	15.8	16.6	17.4
Dry bulb temperature	21 °C	Sensible cooling capacity (kW)	31.2	31.9	32.6	33.2	33.9	34.6
	23 °C		35.5	36.3	37.1	37.8	38.6	39.3
	25 °C		39.9	40.7	41.5	42.4	43.2	41.5
	27 °C		48.9	48.4	47.6	45.8	43.9	42.0
	29 °C		50.9	49.6	47.7	45.8	43.9	42.0
	31 °C		51.5	49.6	47.7	45.8	43.9	42.0
Wet bulb temperature = 19 °C		Total cooling capacity (kW)	54.5	52.5	50.6	48.6	46.6	44.7
		Total power input (kW)	13.7	14.5	15.3	16.1	16.9	17.7
Dry bulb temperature	21 °C	Sensible cooling capacity (kW)	25.1	25.7	26.2	26.7	27.3	27.8
	23 °C		29.7	30.3	31.0	31.6	32.2	32.9
	25 °C		34.3	35.0	35.7	36.5	37.2	37.9
	27 °C		38.8	39.7	40.5	41.3	42.1	43.0
	29 °C		43.4	44.3	45.2	46.2	46.6	44.7
	31 °C		53.0	52.5	50.6	48.6	46.6	44.7
Wet bulb temperature = 21 °C		Total cooling capacity (kW)	57.7	55.7	53.6	51.5	49.5	47.4
		Total power input (kW)	14.3	15.1	15.9	16.8	17.6	18.4
Dry bulb temperature	23 °C	Sensible cooling capacity (kW)	22.9	23.4	23.9	24.4	24.9	25.4
	25 °C		27.8	28.4	29.0	29.6	30.2	30.7
	27 °C		32.6	33.3	34.0	34.7	35.4	36.1
	29 °C		37.5	38.3	39.1	39.9	40.7	41.5
	31 °C		42.3	43.2	44.1	45.0	45.9	46.8
	33 °C		47.2	48.2	53.7	52.7	51.3	49.6
Wet bulb temperature = 23 °C		Total cooling capacity (kW)	61.0	58.8	56.7	54.5	52.3	50.2
		Total power input (kW)	15.0	15.8	16.7	17.5	18.4	19.2
Dry bulb temperature	25 °C	Sensible cooling capacity (kW)	20.4	20.8	21.2	21.7	22.1	22.5
	27 °C		25.5	26.0	26.6	27.1	27.6	28.2
	29 °C		30.6	31.3	31.9	32.6	33.2	33.9
	31 °C		35.7	36.5	37.2	38.0	38.8	39.5
	33 °C		40.8	41.7	42.6	43.5	44.3	45.2

Heating Capacity Data - RTH 50

OUTDOOR AIR TEMPERATURE (°C)		INDOOR COIL ENTERING AIR TEMPERATURE (°C)							
		18		20		22		24	
Dry bulb temperature	Wet bulb temperature	Total heating capacity (kW)	Total power input (kW)	Total heating capacity (kW)	Total power input (kW)	Total heating capacity (kW)	Total power input (kW)	Total heating capacity (kW)	Total power input (kW)
-7	-8	34.5	11.4	33.8	11.7	32.9	11.9	31.7	12.1
-6	-7	35.2	11.6	34.5	11.8	33.6	12.1	32.4	12.3
-5	-6	36.1	11.8	35.4	12.1	34.4	12.3	33.2	12.5
-4	-5	37.0	12.0	36.2	12.3	35.3	12.5	34.0	12.7
-3	-4	37.9	12.2	37.2	12.5	36.2	12.7	34.9	12.9
-2	-3	38.9	12.5	38.2	12.7	37.1	12.9	35.9	13.1
-1	-2	40.0	12.7	39.2	12.9	38.2	13.2	36.9	13.4
0	-1	41.2	12.9	40.3	13.2	39.3	13.4	37.9	13.6
1	0	42.4	13.2	41.5	13.4	40.4	13.7	39.0	13.9
2	1	43.6	13.4	42.8	13.7	41.6	13.9	40.2	14.2
3	2	45.0	13.7	44.1	14.0	42.9	14.2	41.4	14.4
4	3	46.3	14.0	45.4	14.2	44.2	14.5	42.7	14.7
5	4	47.8	14.2	46.9	14.5	45.6	14.8	44.1	15.0
6	5	49.3	14.5	48.4	14.8	47.1	15.1	45.5	15.3
7	6	50.9	14.8	50.2	15.2	48.6	15.4	46.9	15.6
8	7	52.6	15.1	51.5	15.4	50.1	15.7	48.4	15.9
9	8	54.3	15.3	53.2	15.7	51.8	16.0	50.0	16.2
10	9	56.0	15.6	54.9	16.0	53.4	16.3	51.6	16.5
11	10	57.9	15.9	56.7	16.3	55.2	16.7	53.2	16.8
12	11	59.8	16.2	58.6	16.7	57.0	17.0	55.0	17.2
13	12	61.7	16.5	60.5	17.0	58.8	17.3	56.8	17.5
14	13	63.7	16.9	62.5	17.4	60.8	17.7	58.6	17.9
15	14	65.8	17.2	64.5	17.7	62.7	18.1	60.5	18.2
16	15	68.0	17.5	66.6	18.1	64.8	18.4	62.4	18.6
17	16	70.2	17.8	68.8	18.5	66.9	18.8	64.4	19.0
18	17	72.5	18.2	71.0	18.8	69.0	19.2	66.5	19.3
19	18	74.8	18.5	73.3	19.2	71.2	19.6	68.6	19.7
20	19	77.2	18.9	75.6	19.6	73.5	20.0	70.8	20.1

Cooling Capacity Data - RTL 60 - Nominal Airflow 11500 m³/h

INDOOR COIL ENTERING AIR TEMPERATURE (°C)		OUTDOOR AIR TEMPERATURE (°C)						
		20	25	30	35	40	45	
Wet bulb temperature = 15 °C		Total cooling capacity (kW)	59.6	57.3	55.1	52.9	50.6	48.4
		Total power input (kW)	15.3	16.2	17.1	17.9	18.8	19.7
Dry bulb temperature	21 °C	Sensible cooling capacity (kW)	39.9	40.7	41.6	42.4	43.3	44.1
	23 °C		44.9	45.8	46.8	47.7	48.7	48.4
	25 °C		49.8	57.1	55.1	52.9	50.6	48.4
	27 °C		59.6	57.3	55.1	52.9	50.6	48.4
	29 °C		59.6	57.3	55.1	52.9	50.6	48.4
	31 °C		59.6	57.3	55.1	52.9	50.6	48.4
Wet bulb temperature = 17 °C		Total cooling capacity (kW)	63.3	61.0	58.6	56.3	54.0	51.6
		Total power input (kW)	15.4	16.3	17.2	18.1	19.0	19.9
Dry bulb temperature	21 °C	Sensible cooling capacity (kW)	38.4	39.3	40.1	40.9	41.7	42.5
	23 °C		43.7	44.7	45.6	46.5	47.5	48.4
	25 °C		49.0	50.1	51.1	52.2	53.2	51.1
	27 °C		60.2	59.6	58.6	56.3	54.0	51.6
	29 °C		62.7	61.0	58.6	56.3	54.0	51.6
	31 °C		63.3	61.0	58.6	56.3	54.0	51.6
Wet bulb temperature = 19 °C		Total cooling capacity (kW)	67.1	64.6	62.2	59.8	57.4	55.0
		Total power input (kW)	15.6	16.6	17.5	18.4	19.3	20.2
Dry bulb temperature	21 °C	Sensible cooling capacity (kW)	30.9	31.6	32.2	32.9	33.5	34.2
	23 °C		36.5	37.3	38.1	38.9	39.6	40.4
	25 °C		42.2	43.1	44.0	44.9	45.7	46.6
	27 °C		47.8	48.8	49.8	50.8	51.8	52.9
	29 °C		53.4	54.5	55.7	56.8	57.4	55.0
	31 °C		65.2	64.6	62.2	59.8	57.4	55.0
Wet bulb temperature = 21 °C		Total cooling capacity (kW)	71.0	68.5	66.0	63.4	60.9	58.3
		Total power input (kW)	16.3	17.3	18.2	19.2	20.1	21.1
Dry bulb temperature	23 °C	Sensible cooling capacity (kW)	28.2	28.8	29.4	30.0	30.6	31.2
	25 °C		34.2	34.9	35.6	36.4	37.1	37.8
	27 °C		40.2	41.0	41.9	42.7	43.6	44.4
	29 °C		46.1	47.1	48.1	49.1	50.0	51.0
	31 °C		52.1	53.2	54.3	55.4	56.5	57.6
	33 °C		58.0	59.3	66.1	64.8	63.1	61.1
Wet bulb temperature = 23 °C		Total cooling capacity (kW)	75.0	72.4	69.7	67.1	64.4	61.7
		Total power input (kW)	17.1	18.1	19.1	20.0	21.0	22.0
Dry bulb temperature	25 °C	Sensible cooling capacity (kW)	25.0	25.6	26.1	26.6	27.2	27.7
	27 °C		31.3	32.0	32.7	33.3	34.0	34.7
	29 °C		37.7	38.5	39.3	40.1	40.9	41.7
	31 °C		44.0	44.9	45.8	46.8	47.7	48.6
	33 °C		50.3	51.3	52.4	53.5	54.5	55.6

Cooling Capacity Data - RTH 60 - Nominal Airflow 11500 m³/h

INDOOR COIL ENTERING AIR TEMPERATURE (°C)			OUTDOOR AIR TEMPERATURE (°C)					
			20	25	30	35	40	45
Wet bulb temperature = 15 °C		Total cooling capacity (kW)	58.8	56.6	54.4	52.1	49.9	47.7
		Total power input (kW)	15.3	16.2	17.1	17.9	18.8	19.7
Dry bulb temperature	21 °C	Sensible cooling capacity (kW)	39.4	40.2	41.0	41.9	42.7	43.6
	23 °C		44.3	45.2	46.2	47.1	48.0	47.7
	25 °C		49.2	56.3	54.4	52.1	49.9	47.7
	27 °C		58.8	56.6	54.4	52.1	49.9	47.7
	29 °C		58.8	56.6	54.4	52.1	49.9	47.7
	31 °C		58.8	56.6	54.4	52.1	49.9	47.7
Wet bulb temperature = 17 °C		Total cooling capacity (kW)	62.5	60.2	57.9	55.6	53.3	51.0
		Total power input (kW)	15.4	16.3	17.2	18.1	19.0	19.9
Dry bulb temperature	21 °C	Sensible cooling capacity (kW)	37.9	38.7	39.5	40.4	41.2	42.0
	23 °C		43.2	44.1	45.0	45.9	46.8	47.7
	25 °C		48.4	49.4	50.4	51.5	52.5	50.4
	27 °C		59.4	58.8	57.8	55.6	53.3	51.0
	29 °C		61.8	60.2	57.9	55.6	53.3	51.0
	31 °C		62.5	60.2	57.9	55.6	53.3	51.0
Wet bulb temperature = 19 °C		Total cooling capacity (kW)	66.2	63.8	61.4	59.0	56.6	54.2
		Total power input (kW)	15.6	16.6	17.5	18.4	19.3	20.2
Dry bulb temperature	21 °C	Sensible cooling capacity (kW)	30.5	31.2	31.8	32.5	33.1	33.7
	23 °C		36.0	36.8	37.6	38.4	39.1	39.9
	25 °C		41.6	42.5	43.4	44.3	45.1	46.0
	27 °C		47.1	48.1	49.1	50.2	51.2	52.2
	29 °C		52.7	53.8	54.9	56.1	56.6	54.2
	31 °C		64.3	63.7	61.4	59.0	56.6	54.2
Wet bulb temperature = 21 °C		Total cooling capacity (kW)	70.1	67.6	65.1	62.6	60.1	57.6
		Total power input (kW)	16.3	17.3	18.2	19.2	20.1	21.1
Dry bulb temperature	23 °C	Sensible cooling capacity (kW)	27.9	28.4	29.0	29.6	30.2	30.8
	25 °C		33.7	34.5	35.2	35.9	36.6	37.3
	27 °C		39.6	40.5	41.3	42.1	43.0	43.8
	29 °C		45.5	46.5	47.4	48.4	49.4	50.3
	31 °C		51.4	52.5	53.6	54.7	55.8	56.8
	33 °C		57.3	58.5	65.2	63.9	62.3	60.3
Wet bulb temperature = 23 °C		Total cooling capacity (kW)	74.0	71.4	68.8	66.2	63.5	60.9
		Total power input (kW)	17.1	18.1	19.1	20.0	21.0	22.0
Dry bulb temperature	25 °C	Sensible cooling capacity (kW)	24.7	25.2	25.8	26.3	26.8	27.3
	27 °C		30.9	31.6	32.2	32.9	33.6	34.2
	29 °C		37.1	37.9	38.7	39.5	40.3	41.1
	31 °C		43.4	44.3	45.2	46.1	47.1	48.0
	33 °C		49.6	50.6	51.7	52.8	53.8	54.9

Heating Capacity Data - RTH 60

OUTDOOR AIR TEMPERATURE (°C)		INDOOR COIL ENTERING AIR TEMPERATURE (°C)							
		18		20		22		24	
Dry bulb temperature	Wet bulb temperature	Total heating capacity (kW)	Total power input (kW)	Total heating capacity (kW)	Total power input (kW)	Total heating capacity (kW)	Total power input (kW)	Total heating capacity (kW)	Total power input (kW)
-7	-8	40.0	13.3	39.2	13.6	38.1	13.9	36.7	14.1
-6	-7	40.9	13.6	40.1	13.9	39.0	14.1	37.6	14.4
-5	-6	41.8	13.8	41.0	14.1	39.9	14.4	38.5	14.6
-4	-5	42.9	14.1	42.0	14.4	40.9	14.6	39.5	14.9
-3	-4	44.0	14.3	43.1	14.6	41.9	14.9	40.5	15.1
-2	-3	45.1	14.6	44.3	14.9	43.1	15.2	41.6	15.4
-1	-2	46.4	14.9	45.5	15.2	44.3	15.4	42.8	15.7
0	-1	47.7	15.2	46.8	15.4	45.5	15.7	44.0	16.0
1	0	49.1	15.4	48.1	15.7	46.9	16.0	45.3	16.3
2	1	50.6	15.7	49.6	16.0	48.3	16.3	46.6	16.6
3	2	52.1	16.0	51.1	16.4	49.7	16.6	48.0	16.9
4	3	53.7	16.3	52.7	16.7	51.3	17.0	49.5	17.2
5	4	55.4	16.7	54.3	17.0	52.9	17.3	51.1	17.5
6	5	57.2	17.0	56.1	17.3	54.6	17.6	52.7	17.9
7	6	59.0	17.3	58.2	17.8	56.3	18.0	54.4	18.2
8	7	60.9	17.6	59.7	18.0	58.1	18.4	56.1	18.6
9	8	62.9	18.0	61.7	18.4	60.0	18.7	57.9	19.0
10	9	65.0	18.3	63.7	18.8	62.0	19.1	59.8	19.3
11	10	67.1	18.7	65.8	19.1	64.0	19.5	61.7	19.7
12	11	69.3	19.0	67.9	19.5	66.1	19.9	63.7	20.1
13	12	71.6	19.4	70.1	19.9	68.2	20.3	65.8	20.5
14	13	73.9	19.7	72.4	20.3	70.4	20.7	67.9	20.9
15	14	76.3	20.1	74.8	20.8	72.7	21.2	70.1	21.3
16	15	78.8	20.5	77.2	21.2	75.1	21.6	72.4	21.8
17	16	81.4	20.9	79.7	21.6	77.5	22.0	74.7	22.2
18	17	84.0	21.3	82.3	22.0	80.0	22.5	77.1	22.6
19	18	86.7	21.7	85.0	22.5	82.6	23.0	79.5	23.1
20	19	89.5	22.1	87.7	23.0	85.2	23.4	82.0	23.6

Cooling Capacity Data - RTL 70 - Nominal Airflow 12500 m³/h

INDOOR COIL ENTERING AIR TEMPERATURE (°C)		OUTDOOR AIR TEMPERATURE (°C)						
		20	25	30	35	40	45	
Wet bulb temperature = 15 °C		Total cooling capacity (kW)	67.5	64.9	62.4	59.8	57.3	54.8
		Total power input (kW)	17.4	18.4	19.4	20.4	21.4	22.3
Dry bulb temperature	21 °C	Sensible cooling capacity (kW)	45.2	46.1	47.1	48.1	49.0	50.0
	23 °C		50.8	51.9	53.0	54.0	55.1	54.8
	25 °C		56.4	64.6	62.4	59.8	57.3	54.8
	27 °C		67.5	64.9	62.4	59.8	57.3	54.8
	29 °C		67.5	64.9	62.4	59.8	57.3	54.8
	31 °C		67.5	64.9	62.4	59.8	57.3	54.8
Wet bulb temperature = 17 °C		Total cooling capacity (kW)	71.7	69.0	66.4	63.7	61.1	58.5
		Total power input (kW)	17.5	18.5	19.5	20.6	21.6	22.6
Dry bulb temperature	21 °C	Sensible cooling capacity (kW)	43.5	44.5	45.4	46.3	47.2	48.2
	23 °C		49.5	50.6	51.6	52.7	53.7	54.8
	25 °C		55.5	56.7	57.9	59.1	60.2	57.8
	27 °C		68.1	67.4	66.4	63.7	61.1	58.5
	29 °C		70.9	69.0	66.4	63.7	61.1	58.5
	31 °C		71.7	69.0	66.4	63.7	61.1	58.5
Wet bulb temperature = 19 °C		Total cooling capacity (kW)	75.9	73.2	70.4	67.7	65.0	62.2
		Total power input (kW)	17.8	18.8	19.9	20.9	21.9	23.0
Dry bulb temperature	21 °C	Sensible cooling capacity (kW)	35.0	35.7	36.5	37.2	38.0	38.7
	23 °C		41.4	42.2	43.1	44.0	44.9	45.8
	25 °C		47.7	48.7	49.8	50.8	51.8	52.8
	27 °C		54.1	55.2	56.4	57.5	58.7	59.8
	29 °C		60.5	61.7	63.0	64.3	65.0	62.2
	31 °C		73.8	73.1	70.4	67.7	65.0	62.2
Wet bulb temperature = 21 °C		Total cooling capacity (kW)	80.4	77.5	74.7	71.8	68.9	66.0
		Total power input (kW)	18.5	19.6	20.7	21.8	22.8	23.9
Dry bulb temperature	23 °C	Sensible cooling capacity (kW)	32.0	32.6	33.3	34.0	34.7	35.4
	25 °C		38.7	39.5	40.4	41.2	42.0	42.8
	27 °C		45.5	46.4	47.4	48.4	49.3	50.3
	29 °C		52.2	53.3	54.4	55.5	56.7	57.8
	31 °C		59.0	60.2	61.5	62.7	64.0	65.2
	33 °C		65.7	67.1	74.8	73.4	71.5	69.2
Wet bulb temperature = 23 °C		Total cooling capacity (kW)	85.0	81.9	78.9	75.9	72.9	69.9
		Total power input (kW)	19.4	20.6	21.7	22.8	23.9	25.0
Dry bulb temperature	25 °C	Sensible cooling capacity (kW)	28.4	29.0	29.6	30.2	30.8	31.4
	27 °C		35.5	36.2	37.0	37.8	38.5	39.3
	29 °C		42.6	43.5	44.4	45.3	46.3	47.2
	31 °C		49.8	50.8	51.9	52.9	54.0	55.1
	33 °C		56.9	58.1	59.3	60.5	61.7	63.0

Cooling Capacity Data - RTH 70 - Nominal Airflow 12500 m³/h

INDOOR COIL ENTERING AIR TEMPERATURE (°C)		OUTDOOR AIR TEMPERATURE (°C)						
		20	25	30	35	40	45	
Wet bulb temperature = 15 °C		Total cooling capacity (kW)	65.8	63.3	60.8	58.3	55.9	53.4
		Total power input (kW)	17.4	18.4	19.4	20.4	21.4	22.3
Dry bulb temperature	21 °C	Sensible cooling capacity (kW)	44.0	45.0	45.9	46.8	47.8	48.7
	23 °C		49.5	50.6	51.6	52.7	53.7	53.4
	25 °C		55.0	63.0	60.8	58.3	55.9	53.4
	27 °C		65.8	63.3	60.8	58.3	55.9	53.4
	29 °C		65.8	63.3	60.8	58.3	55.9	53.4
	31 °C		65.8	63.3	60.8	58.3	55.9	53.4
Wet bulb temperature = 17 °C		Total cooling capacity (kW)	69.9	67.3	64.7	62.1	59.6	57.0
		Total power input (kW)	17.5	18.5	19.5	20.6	21.6	22.6
Dry bulb temperature	21 °C	Sensible cooling capacity (kW)	42.4	43.3	44.2	45.1	46.0	46.9
	23 °C		48.3	49.3	50.3	51.4	52.4	53.4
	25 °C		54.1	55.3	56.4	57.6	58.7	56.4
	27 °C		66.4	65.7	64.7	62.1	59.6	57.0
	29 °C		69.2	67.3	64.7	62.1	59.6	57.0
	31 °C		69.9	67.3	64.7	62.1	59.6	57.0
Wet bulb temperature = 19 °C		Total cooling capacity (kW)	74.0	71.3	68.7	66.0	63.3	60.7
		Total power input (kW)	17.8	18.8	19.9	20.9	21.9	23.0
Dry bulb temperature	21 °C	Sensible cooling capacity (kW)	34.1	34.8	35.6	36.3	37.0	37.8
	23 °C		40.3	41.2	42.0	42.9	43.8	44.6
	25 °C		46.5	47.5	48.5	49.5	50.5	51.5
	27 °C		52.7	53.9	55.0	56.1	57.2	58.3
	29 °C		58.9	60.2	61.4	62.7	63.3	60.7
	31 °C		71.9	71.3	68.7	66.0	63.3	60.7
Wet bulb temperature = 21 °C		Total cooling capacity (kW)	78.4	75.6	72.8	70.0	67.2	64.4
		Total power input (kW)	18.5	19.6	20.7	21.8	22.8	23.9
Dry bulb temperature	23 °C	Sensible cooling capacity (kW)	31.2	31.8	32.5	33.1	33.8	34.5
	25 °C		37.7	38.5	39.3	40.1	41.0	41.8
	27 °C		44.3	45.3	46.2	47.1	48.1	49.0
	29 °C		50.9	52.0	53.1	54.1	55.2	56.3
	31 °C		57.5	58.7	59.9	61.1	62.4	63.6
	33 °C		64.1	65.4	73.0	71.5	69.7	67.4
Wet bulb temperature = 23 °C		Total cooling capacity (kW)	82.8	79.9	77.0	74.0	71.1	68.1
		Total power input (kW)	19.4	20.6	21.7	22.8	23.9	25.0
Dry bulb temperature	25 °C	Sensible cooling capacity (kW)	27.6	28.2	28.8	29.4	30.0	30.6
	27 °C		34.6	35.3	36.1	36.8	37.5	38.3
	29 °C		41.6	42.4	43.3	44.2	45.1	46.0
	31 °C		48.5	49.5	50.6	51.6	52.6	53.7
	33 °C		55.5	56.6	57.8	59.0	60.2	61.4

Heating Capacity Data - RTH 70

OUTDOOR AIR TEMPERATURE (°C)		INDOOR COIL ENTERING AIR TEMPERATURE (°C)							
		18		20		22		24	
Dry bulb temperature	Wet bulb temperature	Total heating capacity (kW)	Total power input (kW)	Total heating capacity (kW)	Total power input (kW)	Total heating capacity (kW)	Total power input (kW)	Total heating capacity (kW)	Total power input (kW)
-7	-8	45.7	15.2	44.8	15.6	43.5	15.9	42.0	16.1
-6	-7	46.7	15.5	45.8	15.8	44.5	16.1	42.9	16.4
-5	-6	47.8	15.8	46.8	16.1	45.6	16.4	44.0	16.7
-4	-5	49.0	16.1	48.0	16.4	46.7	16.7	45.1	16.9
-3	-4	50.2	16.4	49.2	16.7	47.9	17.0	46.3	17.2
-2	-3	51.6	16.7	50.6	17.0	49.2	17.3	47.5	17.6
-1	-2	53.0	17.0	52.0	17.3	50.6	17.6	48.8	17.9
0	-1	54.5	17.3	53.4	17.6	52.0	17.9	50.3	18.2
1	0	56.1	17.6	55.0	18.0	53.6	18.3	51.7	18.6
2	1	57.8	17.9	56.7	18.3	55.2	18.6	53.3	18.9
3	2	59.6	18.3	58.4	18.6	56.8	19.0	54.9	19.3
4	3	61.4	18.6	60.2	19.0	58.6	19.3	56.6	19.6
5	4	63.3	19.0	62.1	19.4	60.4	19.7	58.4	20.0
6	5	65.3	19.4	64.1	19.8	62.3	20.1	60.2	20.4
7	6	67.4	19.7	66.5	20.3	64.3	20.5	62.1	20.8
8	7	69.6	20.1	68.2	20.6	66.4	20.9	64.1	21.2
9	8	71.9	20.5	70.5	21.0	68.6	21.4	66.2	21.6
10	9	74.2	20.9	72.8	21.4	70.8	21.8	68.3	22.1
11	10	76.7	21.3	75.1	21.8	73.1	22.2	70.5	22.5
12	11	79.2	21.7	77.6	22.3	75.5	22.7	72.8	22.9
13	12	81.8	22.1	80.1	22.7	77.9	23.2	75.2	23.4
14	13	84.4	22.5	82.8	23.2	80.5	23.6	77.6	23.9
15	14	87.2	22.9	85.5	23.7	83.1	24.1	80.1	24.3
16	15	90.0	23.4	88.2	24.1	85.8	24.6	82.7	24.8
17	16	93.0	23.8	91.1	24.6	88.6	25.1	85.3	25.3
18	17	96.0	24.3	94.1	25.1	91.4	25.7	88.1	25.8
19	18	99.1	24.7	97.1	25.7	94.4	26.2	90.9	26.3
20	19	102.3	25.2	100.2	26.2	97.4	26.7	93.7	26.9

Cooling Capacity Data - RTL 80 - Nominal Airflow 16500 m³/h

INDOOR COIL ENTERING AIR TEMPERATURE (°C)		OUTDOOR AIR TEMPERATURE (°C)						
		20	25	30	35	40	45	
Wet bulb temperature = 15 °C		Total cooling capacity (kW)	84.6	81.4	78.2	75.0	71.9	68.7
		Total power input (kW)	21.6	22.9	24.1	25.3	26.6	27.8
Dry bulb temperature	21 °C	Sensible cooling capacity (kW)	56.6	57.9	59.1	60.3	61.5	62.7
	23 °C		63.7	65.1	66.4	67.8	69.1	68.7
	25 °C		70.8	81.0	78.2	75.0	71.9	68.7
	27 °C		84.6	81.4	78.2	75.0	71.9	68.7
	29 °C		84.6	81.4	78.2	75.0	71.9	68.7
	31 °C		84.6	81.4	78.2	75.0	71.9	68.7
Wet bulb temperature = 17 °C		Total cooling capacity (kW)	89.9	86.6	83.3	79.9	76.6	73.3
		Total power input (kW)	21.8	23.1	24.3	25.6	26.8	28.1
Dry bulb temperature	21 °C	Sensible cooling capacity (kW)	54.6	55.7	56.9	58.1	59.2	60.4
	23 °C		62.1	63.4	64.7	66.1	67.4	68.7
	25 °C		69.6	71.1	72.6	74.1	75.5	72.5
	27 °C		85.4	84.6	83.2	79.9	76.6	73.3
	29 °C		89.0	86.6	83.3	79.9	76.6	73.3
	31 °C		89.9	86.6	83.3	79.9	76.6	73.3
Wet bulb temperature = 19 °C		Total cooling capacity (kW)	95.2	91.8	88.3	84.9	81.5	78.0
		Total power input (kW)	22.1	23.4	24.7	26.0	27.3	28.6
Dry bulb temperature	21 °C	Sensible cooling capacity (kW)	43.9	44.8	45.8	46.7	47.6	48.6
	23 °C		51.9	53.0	54.1	55.2	56.3	57.4
	25 °C		59.9	61.1	62.4	63.7	64.9	66.2
	27 °C		67.8	69.3	70.7	72.2	73.6	75.1
	29 °C		75.8	77.4	79.0	80.7	81.5	78.0
	31 °C		92.5	91.7	88.3	84.9	81.5	78.0
Wet bulb temperature = 21 °C		Total cooling capacity (kW)	100.9	97.3	93.6	90.0	86.4	82.8
		Total power input (kW)	23.1	24.4	25.7	27.1	28.4	29.8
Dry bulb temperature	23 °C	Sensible cooling capacity (kW)	40.1	40.9	41.8	42.6	43.5	44.3
	25 °C		48.5	49.6	50.6	51.6	52.7	53.7
	27 °C		57.0	58.2	59.4	60.6	61.9	63.1
	29 °C		65.5	66.9	68.3	69.7	71.0	72.4
	31 °C		73.9	75.5	77.1	78.7	80.2	81.8
	33 °C		82.4	84.2	93.9	92.0	89.6	86.7
Wet bulb temperature = 23 °C		Total cooling capacity (kW)	106.5	102.8	99.0	95.2	91.4	87.7
		Total power input (kW)	24.2	25.6	27.0	28.3	29.7	31.1
Dry bulb temperature	25 °C	Sensible cooling capacity (kW)	35.6	36.3	37.1	37.8	38.6	39.3
	27 °C		44.5	45.5	46.4	47.3	48.3	49.2
	29 °C		53.5	54.6	55.7	56.9	58.0	59.1
	31 °C		62.4	63.7	65.1	66.4	67.7	69.0
	33 °C		71.4	72.9	74.4	75.9	77.4	78.9

Cooling Capacity Data - RTH 80 - Nominal Airflow 16500 m³/h

INDOOR COIL ENTERING AIR TEMPERATURE (°C)			OUTDOOR AIR TEMPERATURE (°C)					
			20	25	30	35	40	45
Wet bulb temperature = 15 °C		Total cooling capacity (kW)	83.1	80.0	76.8	73.7	70.6	67.5
		Total power input (kW)	21.6	22.9	24.1	25.3	26.6	27.8
Dry bulb temperature	21 °C	Sensible cooling capacity (kW)	55.6	56.8	58.0	59.2	60.4	61.6
	23 °C		62.6	63.9	65.2	66.6	67.9	67.5
	25 °C		69.5	79.6	76.8	73.7	70.6	67.5
	27 °C		83.1	80.0	76.8	73.7	70.6	67.5
	29 °C		83.1	80.0	76.8	73.7	70.6	67.5
	31 °C		83.1	80.0	76.8	73.7	70.6	67.5
Wet bulb temperature = 17 °C		Total cooling capacity (kW)	88.3	85.0	81.8	78.5	75.3	72.0
		Total power input (kW)	21.8	23.1	24.3	25.6	26.8	28.1
Dry bulb temperature	21 °C	Sensible cooling capacity (kW)	53.6	54.8	55.9	57.0	58.2	59.3
	23 °C		61.0	62.3	63.6	64.9	66.2	67.5
	25 °C		68.4	69.8	71.3	72.8	74.2	71.3
	27 °C		83.9	83.1	81.7	78.5	75.3	72.0
	29 °C		87.4	85.0	81.8	78.5	75.3	72.0
	31 °C		88.3	85.0	81.8	78.5	75.3	72.0
Wet bulb temperature = 19 °C		Total cooling capacity (kW)	93.5	90.2	86.8	83.4	80.0	76.6
		Total power input (kW)	22.1	23.4	24.7	26.0	27.3	28.6
Dry bulb temperature	21 °C	Sensible cooling capacity (kW)	43.1	44.0	45.0	45.9	46.8	47.7
	23 °C		51.0	52.0	53.1	54.2	55.3	56.4
	25 °C		58.8	60.0	61.3	62.6	63.8	65.1
	27 °C		66.6	68.1	69.5	70.9	72.3	73.7
	29 °C		74.5	76.1	77.6	79.2	80.0	76.6
	31 °C		90.9	90.1	86.8	83.4	80.0	76.6
Wet bulb temperature = 21 °C		Total cooling capacity (kW)	99.1	95.5	92.0	88.4	84.9	81.4
		Total power input (kW)	23.1	24.4	25.7	27.1	28.4	29.8
Dry bulb temperature	23 °C	Sensible cooling capacity (kW)	39.4	40.2	41.1	41.9	42.7	43.6
	25 °C		47.7	48.7	49.7	50.7	51.7	52.8
	27 °C		56.0	57.2	58.4	59.6	60.8	62.0
	29 °C		64.3	65.7	67.1	68.4	69.8	71.2
	31 °C		72.6	74.2	75.7	77.3	78.8	80.4
	33 °C		80.9	82.7	92.2	90.4	88.0	85.2
Wet bulb temperature = 23 °C		Total cooling capacity (kW)	104.7	101.0	97.2	93.5	89.8	86.1
		Total power input (kW)	24.2	25.6	27.0	28.3	29.7	31.1
Dry bulb temperature	25 °C	Sensible cooling capacity (kW)	34.9	35.7	36.4	37.2	37.9	38.6
	27 °C		43.7	44.6	45.6	46.5	47.4	48.4
	29 °C		52.5	53.6	54.7	55.9	57.0	58.1
	31 °C		61.3	62.6	63.9	65.2	66.5	67.8
	33 °C		70.1	71.6	73.1	74.6	76.1	77.6

Heating Capacity Data - RTH 80

OUTDOOR AIR TEMPERATURE (°C)		INDOOR COIL ENTERING AIR TEMPERATURE (°C)							
		18		20		22		24	
Dry bulb temperature	Wet bulb temperature	Total heating capacity (kW)	Total power input (kW)	Total heating capacity (kW)	Total power input (kW)	Total heating capacity (kW)	Total power input (kW)	Total heating capacity (kW)	Total power input (kW)
-7	-8	57.7	18.1	56.6	18.5	55.0	18.8	53.0	19.1
-6	-7	59.0	18.4	57.8	18.8	56.2	19.1	54.2	19.4
-5	-6	60.4	18.7	59.2	19.1	57.6	19.5	55.5	19.8
-4	-5	61.8	19.1	60.6	19.4	59.0	19.8	56.9	20.1
-3	-4	63.4	19.4	62.2	19.8	60.5	20.2	58.4	20.5
-2	-3	65.1	19.8	63.9	20.2	62.2	20.5	60.0	20.8
-1	-2	66.9	20.1	65.6	20.5	63.9	20.9	61.7	21.2
0	-1	68.9	20.5	67.5	20.9	65.7	21.3	63.5	21.6
1	0	70.9	20.9	69.5	21.3	67.6	21.7	65.3	22.0
2	1	73.0	21.3	71.6	21.7	69.7	22.1	67.3	22.4
3	2	75.2	21.7	73.8	22.1	71.8	22.5	69.3	22.9
4	3	77.6	22.1	76.0	22.6	74.0	23.0	71.5	23.3
5	4	80.0	22.5	78.4	23.0	76.3	23.4	73.7	23.8
6	5	82.5	23.0	80.9	23.5	78.8	23.9	76.1	24.2
7	6	85.2	23.4	84.0	24.1	81.3	24.4	78.5	24.7
8	7	87.9	23.9	86.2	24.4	83.9	24.9	81.0	25.2
9	8	90.8	24.3	89.0	24.9	86.6	25.4	83.6	25.7
10	9	93.8	24.8	91.9	25.4	89.4	25.9	86.3	26.2
11	10	96.8	25.3	94.9	25.9	92.3	26.4	89.1	26.7
12	11	100.0	25.7	98.0	26.4	95.3	26.9	92.0	27.2
13	12	103.3	26.2	101.2	27.0	98.5	27.5	95.0	27.8
14	13	106.7	26.7	104.5	27.5	101.7	28.1	98.0	28.3
15	14	110.1	27.2	108.0	28.1	105.0	28.7	101.2	28.9
16	15	113.7	27.7	111.5	28.7	108.4	29.2	104.5	29.5
17	16	117.4	28.3	115.1	29.3	111.9	29.9	107.8	30.1
18	17	121.2	28.8	118.8	29.9	115.5	30.5	111.3	30.7
19	18	125.2	29.3	122.6	30.5	119.2	31.1	114.8	31.3
20	19	129.2	29.9	126.6	31.1	123.0	31.7	118.4	31.9

Cooling Capacity Data - RTL 100 - Nominal Airflow 18650 m³/h

INDOOR COIL ENTERING AIR TEMPERATURE (°C)		OUTDOOR AIR TEMPERATURE (°C)						
		20	25	30	35	40	45	
Wet bulb temperature = 15 °C		Total cooling capacity (kW)	96.2	92.6	89.0	85.4	81.8	78.1
		Total power input (kW)	25.7	27.2	28.6	30.1	31.6	33.0
Dry bulb temperature	21 °C	Sensible cooling capacity (kW)	64.5	65.8	67.2	68.6	69.9	71.3
	23 °C		72.5	74.0	75.6	77.1	78.6	78.1
	25 °C		80.5	92.2	89.0	85.4	81.8	78.1
	27 °C		96.2	92.6	89.0	85.4	81.8	78.1
	29 °C		96.2	92.6	89.0	85.4	81.8	78.1
	31 °C		96.2	92.6	89.0	85.4	81.8	78.1
Wet bulb temperature = 17 °C		Total cooling capacity (kW)	102.3	98.5	94.7	91.0	87.2	83.4
		Total power input (kW)	25.9	27.4	28.9	30.4	31.9	33.4
Dry bulb temperature	21 °C	Sensible cooling capacity (kW)	62.1	63.4	64.8	66.1	67.4	68.7
	23 °C		70.7	72.2	73.7	75.2	76.7	78.2
	25 °C		79.2	80.9	82.6	84.3	86.0	82.5
	27 °C		97.2	96.2	94.7	91.0	87.2	83.4
	29 °C		101.2	98.5	94.7	91.0	87.2	83.4
	31 °C		102.3	98.5	94.7	91.0	87.2	83.4
Wet bulb temperature = 19 °C		Total cooling capacity (kW)	108.3	104.4	100.5	96.6	92.7	88.8
		Total power input (kW)	26.3	27.8	29.4	30.9	32.4	34.0
Dry bulb temperature	21 °C	Sensible cooling capacity (kW)	49.9	51.0	52.1	53.1	54.2	55.3
	23 °C		59.0	60.3	61.5	62.8	64.0	65.3
	25 °C		68.1	69.6	71.0	72.5	73.9	75.3
	27 °C		77.2	78.8	80.5	82.1	83.8	85.4
	29 °C		86.3	88.1	89.9	91.8	92.7	88.8
	31 °C		105.3	104.3	100.5	96.6	92.7	88.8
Wet bulb temperature = 21 °C		Total cooling capacity (kW)	114.8	110.7	106.5	102.4	98.3	94.2
		Total power input (kW)	27.4	29.0	30.6	32.2	33.8	35.4
Dry bulb temperature	23 °C	Sensible cooling capacity (kW)	45.6	46.6	47.5	48.5	49.5	50.5
	25 °C		55.2	56.4	57.6	58.8	59.9	61.1
	27 °C		64.9	66.2	67.6	69.0	70.4	71.8
	29 °C		74.5	76.1	77.7	79.3	80.8	82.4
	31 °C		84.1	85.9	87.7	89.5	91.3	93.1
	33 °C		93.8	95.7	106.8	104.7	102.0	98.7
Wet bulb temperature = 23 °C		Total cooling capacity (kW)	121.2	116.9	112.6	108.3	104.0	99.7
		Total power input (kW)	28.8	30.4	32.0	33.7	35.3	36.9
Dry bulb temperature	25 °C	Sensible cooling capacity (kW)	40.5	41.3	42.2	43.0	43.9	44.8
	27 °C		50.6	51.7	52.8	53.9	54.9	56.0
	29 °C		60.8	62.1	63.4	64.7	66.0	67.3
	31 °C		71.0	72.5	74.0	75.5	77.0	78.6
	33 °C		81.2	82.9	84.6	86.4	88.1	89.8

Cooling Capacity Data - RTH 100 - Nominal Airflow 18650 m³/h

INDOOR COIL ENTERING AIR TEMPERATURE (°C)			OUTDOOR AIR TEMPERATURE (°C)					
			20	25	30	35	40	45
Wet bulb temperature = 15 °C		Total cooling capacity (kW)	94.5	90.9	87.3	83.8	80.2	76.7
		Total power input (kW)	24.9	26.3	27.7	29.1	30.5	32.0
Dry bulb temperature	21 °C	Sensible cooling capacity (kW)	63.3	64.6	65.9	67.3	68.6	70.0
	23 °C		71.1	72.6	74.2	75.7	77.2	76.7
	25 °C		79.0	90.5	87.3	83.8	80.2	76.7
	27 °C		94.5	90.9	87.3	83.8	80.2	76.7
	29 °C		94.5	90.9	87.3	83.8	80.2	76.7
	31 °C		94.5	90.9	87.3	83.8	80.2	76.7
Wet bulb temperature = 17 °C		Total cooling capacity (kW)	100.4	96.7	93.0	89.3	85.6	81.9
		Total power input (kW)	25.1	26.5	28.0	29.4	30.9	32.3
Dry bulb temperature	21 °C	Sensible cooling capacity (kW)	61.0	62.2	63.5	64.8	66.1	67.4
	23 °C		69.3	70.8	72.3	73.8	75.2	76.7
	25 °C		77.7	79.4	81.0	82.7	84.3	81.0
	27 °C		95.4	94.4	92.9	89.3	85.6	81.9
	29 °C		99.4	96.7	93.0	89.3	85.6	81.9
	31 °C		100.4	96.7	93.0	89.3	85.6	81.9
Wet bulb temperature = 19 °C		Total cooling capacity (kW)	106.3	102.5	98.6	94.8	91.0	87.1
		Total power input (kW)	25.4	26.9	28.4	29.9	31.4	32.9
Dry bulb temperature	21 °C	Sensible cooling capacity (kW)	49.0	50.1	51.1	52.1	53.2	54.2
	23 °C		57.9	59.2	60.4	61.6	62.9	64.1
	25 °C		66.8	68.3	69.7	71.1	72.5	73.9
	27 °C		75.7	77.4	79.0	80.6	82.2	83.8
	29 °C		84.7	86.5	88.3	90.1	91.0	87.1
	31 °C		103.3	102.4	98.6	94.8	91.0	87.1
Wet bulb temperature = 21 °C		Total cooling capacity (kW)	112.6	108.6	104.6	100.5	96.5	92.5
		Total power input (kW)	26.5	28.1	29.6	31.1	32.7	34.2
Dry bulb temperature	23 °C	Sensible cooling capacity (kW)	44.8	45.7	46.7	47.6	48.6	49.5
	25 °C		54.2	55.4	56.5	57.7	58.8	60.0
	27 °C		63.7	65.0	66.4	67.7	69.1	70.4
	29 °C		73.1	74.7	76.2	77.8	79.3	80.9
	31 °C		82.6	84.3	86.1	87.8	89.6	91.3
	33 °C		92.0	94.0	104.8	102.7	100.1	96.8
Wet bulb temperature = 23 °C		Total cooling capacity (kW)	119.0	114.8	110.5	106.3	102.1	97.9
		Total power input (kW)	27.8	29.4	31.0	32.6	34.2	35.7
Dry bulb temperature	25 °C	Sensible cooling capacity (kW)	39.7	40.5	41.4	42.2	43.1	43.9
	27 °C		49.7	50.8	51.8	52.9	53.9	55.0
	29 °C		59.7	61.0	62.2	63.5	64.8	66.0
	31 °C		69.7	71.2	72.6	74.1	75.6	77.1
	33 °C		79.7	81.4	83.1	84.8	86.5	88.2

Heating Capacity Data - RTH 100

OUTDOOR AIR TEMPERATURE (°C)		INDOOR COIL ENTERING AIR TEMPERATURE (°C)							
		18		20		22		24	
Dry bulb temperature	Wet bulb temperature	Total heating capacity (kW)	Total power input (kW)	Total heating capacity (kW)	Total power input (kW)	Total heating capacity (kW)	Total power input (kW)	Total heating capacity (kW)	Total power input (kW)
-7	-8	65.9	20.7	64.6	21.2	62.9	21.6	60.6	21.9
-6	-7	67.4	21.0	66.1	21.5	64.3	21.9	62.0	22.3
-5	-6	69.0	21.4	67.6	21.9	65.8	22.3	63.5	22.6
-4	-5	70.7	21.8	69.3	22.3	67.4	22.7	65.1	23.0
-3	-4	72.5	22.2	71.1	22.7	69.2	23.1	66.8	23.5
-2	-3	74.4	22.6	73.0	23.1	71.0	23.5	68.6	23.9
-1	-2	76.5	23.1	75.0	23.5	73.0	23.9	70.5	24.3
0	-1	78.7	23.5	77.2	24.0	75.1	24.4	72.5	24.8
1	0	81.0	23.9	79.4	24.4	77.3	24.8	74.7	25.2
2	1	83.4	24.4	81.8	24.9	79.6	25.3	76.9	25.7
3	2	86.0	24.9	84.3	25.4	82.1	25.8	79.3	26.2
4	3	88.6	25.3	86.9	25.9	84.6	26.3	81.7	26.7
5	4	91.4	25.8	89.6	26.4	87.2	26.8	84.3	27.2
6	5	94.3	26.3	92.5	26.9	90.0	27.4	86.9	27.7
7	6	97.3	26.8	96.0	27.6	92.9	27.9	89.7	28.3
8	7	100.5	27.3	98.5	28.0	95.9	28.5	92.6	28.8
9	8	103.8	27.8	101.7	28.5	99.0	29.0	95.5	29.4
10	9	107.1	28.4	105.0	29.1	102.2	29.6	98.6	30.0
11	10	110.7	28.9	108.5	29.7	105.5	30.2	101.8	30.6
12	11	114.3	29.5	112.0	30.3	109.0	30.9	105.1	31.2
13	12	118.0	30.0	115.7	30.9	112.5	31.5	108.5	31.8
14	13	121.9	30.6	119.5	31.5	116.2	32.1	112.0	32.4
15	14	125.9	31.2	123.4	32.2	120.0	32.8	115.7	33.1
16	15	130.0	31.8	127.4	32.8	123.9	33.5	119.4	33.8
17	16	134.2	32.4	131.5	33.5	127.9	34.2	123.2	34.4
18	17	138.6	33.0	135.8	34.2	132.0	34.9	127.1	35.1
19	18	143.0	33.6	140.2	34.9	136.2	35.6	131.2	35.8
20	19	147.6	34.2	144.7	35.6	140.6	36.4	135.3	36.5

Cooling Capacity Data - RTL 110 - Nominal Airflow 20000 m³/h

INDOOR COIL ENTERING AIR TEMPERATURE (°C)		OUTDOOR AIR TEMPERATURE (°C)						
		20	25	30	35	40	45	
Wet bulb temperature = 15 °C		Total cooling capacity (kW)	108.0	103.9	99.9	95.8	91.7	87.7
		Total power input (kW)	30.4	32.1	33.8	35.6	37.3	39.0
Dry bulb temperature	21 °C	Sensible cooling capacity (kW)	72.3	73.9	75.4	76.9	78.5	80.0
	23 °C		81.3	83.1	84.8	86.5	88.3	87.7
	25 °C		90.3	103.5	99.9	95.8	91.7	87.7
	27 °C		108.0	103.9	99.9	95.8	91.7	87.7
	29 °C		108.0	103.9	99.9	95.8	91.7	87.7
Wet bulb temperature = 17 °C		Total cooling capacity (kW)	114.8	110.5	106.3	102.1	97.8	93.6
		Total power input (kW)	30.6	32.4	34.1	35.9	37.7	39.5
Dry bulb temperature	21 °C	Sensible cooling capacity (kW)	69.7	71.2	72.7	74.1	75.6	77.1
	23 °C		79.3	81.0	82.7	84.4	86.0	87.7
	25 °C		88.9	90.8	92.7	94.6	96.4	92.6
	27 °C		109.1	108.0	106.3	102.1	97.8	93.6
	29 °C		113.6	110.5	106.3	102.1	97.8	93.6
Wet bulb temperature = 19 °C		Total cooling capacity (kW)	121.6	117.2	112.8	108.4	104.0	99.6
		Total power input (kW)	31.0	32.9	34.7	36.5	38.3	40.2
Dry bulb temperature	21 °C	Sensible cooling capacity (kW)	56.0	57.2	58.4	59.6	60.8	62.0
	23 °C		66.2	67.6	69.1	70.5	71.9	73.3
	25 °C		76.4	78.0	79.7	81.3	82.9	84.6
	27 °C		86.6	88.5	90.3	92.1	94.0	95.8
	29 °C		96.8	98.9	100.9	103.0	104.0	99.6
Wet bulb temperature = 21 °C		Total cooling capacity (kW)	128.8	124.2	119.6	115.0	110.3	105.7
		Total power input (kW)	32.4	34.3	36.1	38.0	39.9	41.8
Dry bulb temperature	23 °C	Sensible cooling capacity (kW)	51.2	52.3	53.4	54.4	55.5	56.6
	25 °C		62.0	63.3	64.6	65.9	67.3	68.6
	27 °C		72.8	74.3	75.9	77.4	79.0	80.5
	29 °C		83.6	85.4	87.2	88.9	90.7	92.5
	31 °C		94.4	96.4	98.4	100.4	102.4	104.4
Wet bulb temperature = 23 °C		Total cooling capacity (kW)	136.0	131.2	126.4	121.6	116.7	111.9
		Total power input (kW)	34.0	35.9	37.8	39.8	41.7	43.6
Dry bulb temperature	25 °C	Sensible cooling capacity (kW)	45.4	46.4	47.3	48.3	49.3	50.2
	27 °C		56.8	58.0	59.2	60.4	61.7	62.9
	29 °C		68.3	69.7	71.2	72.6	74.1	75.5
	31 °C		79.7	81.4	83.1	84.8	86.5	88.2
			91.1	93.0	95.0	96.9	98.9	100.8

Cooling Capacity Data - RTH 110 - Nominal Airflow 20000 m³/h

INDOOR COIL ENTERING AIR TEMPERATURE (°C)			OUTDOOR AIR TEMPERATURE (°C)						
			20	25	30	35	40	45	
Wet bulb temperature = 15 °C			Total cooling capacity (kW)	105.7	101.7	97.8	93.8	89.8	85.8
			Total power input (kW)	29.5	31.2	32.9	34.6	36.3	38.0
Dry bulb temperature	21 °C	Sensible cooling capacity (kW)	70.8	72.3	73.8	75.3	76.8	78.3	
	23 °C		79.6	81.3	83.0	84.7	86.4	85.8	
	25 °C		88.4	101.3	97.8	93.8	89.8	85.8	
	27 °C		105.7	101.7	97.8	93.8	89.8	85.8	
	29 °C		105.7	101.7	97.8	93.8	89.8	85.8	
	31 °C		105.7	101.7	97.8	93.8	89.8	85.8	
Wet bulb temperature = 17 °C			Total cooling capacity (kW)	112.3	108.2	104.0	99.9	95.8	91.6
			Total power input (kW)	29.8	31.5	33.2	34.9	36.6	38.4
Dry bulb temperature	21 °C	Sensible cooling capacity (kW)	68.2	69.7	71.1	72.6	74.0	75.5	
	23 °C		77.6	79.3	80.9	82.6	84.2	85.9	
	25 °C		87.0	88.8	90.7	92.6	94.4	90.7	
	27 °C		106.8	105.7	104.0	99.9	95.8	91.6	
	29 °C		111.2	108.2	104.0	99.9	95.8	91.6	
	31 °C		112.3	108.2	104.0	99.9	95.8	91.6	
Wet bulb temperature = 19 °C			Total cooling capacity (kW)	119.0	114.7	110.4	106.1	101.8	97.5
			Total power input (kW)	30.2	32.0	33.7	35.5	37.3	39.1
Dry bulb temperature	21 °C	Sensible cooling capacity (kW)	54.9	56.0	57.2	58.4	59.5	60.7	
	23 °C		64.8	66.2	67.6	69.0	70.3	71.7	
	25 °C		74.8	76.4	78.0	79.6	81.2	82.8	
	27 °C		84.8	86.6	88.4	90.2	92.0	93.8	
	29 °C		94.7	96.8	98.8	100.8	101.8	97.5	
	31 °C		115.6	114.6	110.4	106.1	101.8	97.5	
Wet bulb temperature = 21 °C			Total cooling capacity (kW)	126.0	121.5	117.0	112.5	108.0	103.5
			Total power input (kW)	31.5	33.3	35.1	37.0	38.8	40.6
Dry bulb temperature	23 °C	Sensible cooling capacity (kW)	50.1	51.2	52.2	53.3	54.4	55.4	
	25 °C		60.7	62.0	63.3	64.5	65.8	67.1	
	27 °C		71.2	72.8	74.3	75.8	77.3	78.8	
	29 °C		81.8	83.6	85.3	87.0	88.8	90.5	
	31 °C		92.4	94.4	96.3	98.3	100.3	102.2	
	33 °C		103.0	105.2	117.3	115.0	112.0	108.4	
Wet bulb temperature = 23 °C			Total cooling capacity (kW)	133.2	128.4	123.7	119.0	114.3	109.5
			Total power input (kW)	33.0	34.9	36.8	38.7	40.6	42.4
Dry bulb temperature	25 °C	Sensible cooling capacity (kW)	44.4	45.4	46.3	47.3	48.2	49.2	
	27 °C		55.6	56.8	58.0	59.2	60.4	61.5	
	29 °C		66.8	68.2	69.6	71.1	72.5	73.9	
	31 °C		78.0	79.6	81.3	83.0	84.6	86.3	
	33 °C		89.2	91.1	93.0	94.9	96.8	98.7	

Heating Capacity Data - RTH 110

OUTDOOR AIR TEMPERATURE (°C)		INDOOR COIL ENTERING AIR TEMPERATURE (°C)							
		18		20		22		24	
Dry bulb temperature	Wet bulb temperature	Total heating capacity (kW)	Total power input (kW)	Total heating capacity (kW)	Total power input (kW)	Total heating capacity (kW)	Total power input (kW)	Total heating capacity (kW)	Total power input (kW)
-7	-8	74.2	24.5	72.7	25.1	70.7	25.5	68.2	25.9
-6	-7	75.8	24.9	74.3	25.5	72.3	26.0	69.7	26.4
-5	-6	77.6	25.4	76.1	25.9	74.0	26.4	71.4	26.8
-4	-5	79.5	25.9	78.0	26.4	75.9	26.9	73.2	27.3
-3	-4	81.6	26.3	80.0	26.9	77.8	27.3	75.1	27.8
-2	-3	83.8	26.8	82.1	27.4	79.9	27.8	77.2	28.3
-1	-2	86.1	27.3	84.4	27.9	82.1	28.3	79.3	28.8
0	-1	88.5	27.8	86.8	28.4	84.5	28.9	81.6	29.3
1	0	91.1	28.4	89.3	28.9	87.0	29.4	84.0	29.9
2	1	93.9	28.9	92.0	29.5	89.6	30.0	86.5	30.4
3	2	96.7	29.5	94.8	30.0	92.3	30.6	89.2	31.0
4	3	99.7	30.0	97.8	30.6	95.2	31.2	91.9	31.6
5	4	102.8	30.6	100.8	31.2	98.1	31.8	94.8	32.2
6	5	106.1	31.2	104.0	31.8	101.3	32.4	97.8	32.9
7	6	109.5	31.8	108.0	32.7	104.5	33.1	100.9	33.5
8	7	113.1	32.4	110.8	33.1	107.9	33.7	104.1	34.2
9	8	116.7	33.0	114.4	33.8	111.4	34.4	107.5	34.8
10	9	120.5	33.6	118.2	34.5	115.0	35.1	111.0	35.5
11	10	124.5	34.3	122.0	35.2	118.7	35.8	114.6	36.2
12	11	128.6	34.9	126.0	35.9	122.6	36.6	118.3	37.0
13	12	132.8	35.6	130.1	36.6	126.6	37.3	122.1	37.7
14	13	137.1	36.3	134.4	37.4	130.7	38.1	126.0	38.4
15	14	141.6	36.9	138.8	38.1	135.0	38.9	130.1	39.2
16	15	146.2	37.6	143.3	38.9	139.3	39.7	134.3	40.0
17	16	151.0	38.4	148.0	39.7	143.8	40.5	138.6	40.8
18	17	155.9	39.1	152.8	40.5	148.5	41.3	143.0	41.6
19	18	160.9	39.8	157.7	41.3	153.2	42.2	147.6	42.4
20	19	166.1	40.6	162.7	42.2	158.1	43.1	152.2	43.3

Performance Data - 1-row Hot Water Coil (optional)

Entering air at 0 °C

Sizes RTL/ RTH	Air flow (m ³ /h)	Water 70 - 50 °C						Water 80 - 60 °C						Water 90 - 70 °C					
		Heat. cap. (kW)	Water flow (kg/s)	Water flow (m ³ /h)	ΔP water (bar)	ΔP air (Pa)	T°C supply air	Heat. cap. (kW)	Water flow (kg/s)	Water flow (m ³ /h)	ΔP water (bar)	ΔP air (Pa)	T°C supply air	Heat. cap. (kW)	Water flow (kg/s)	Water flow (m ³ /h)	ΔP water (bar)	ΔP air (Pa)	T°C supply air
30	5500	46.8	0.6	1.995	0.28	8	22.9	56.1	0.7	2.346	0.36	8	27.4	65.7	0.8	2.749	0.50	9	32.1
40	7650	64.9	0.8	2.764	0.22	10	21.6	78.0	0.9	3.327	0.32	10	26.0	90.6	1.0	3.755	0.39	10	30.2
50	9200	70.3	0.8	2.946	0.27	13	19.5	85.1	1.0	3.627	0.37	14	23.6	99.3	1.2	4.194	0.49	14	27.5
60	11500	87.5	1.0	3.722	0.39	11	21.3	105.3	1.2	4.476	0.55	11	25.6	122.6	1.4	5.130	0.70	11	29.9
70	12500	90.7	1.1	3.838	0.43	12	20.4	109.4	1.3	4.664	0.60	12	24.6	127.8	1.5	5.420	0.80	12	28.7
80	16500	103.4	1.2	4.413	0.55	18	17.6	123.7	1.4	5.160	0.74	18	21.0	144.7	1.7	6.014	0.97	18	24.6
100	18 500	108.7	1.3	4.627	0.27	22	16.5	130.9	1.5	5.581	0.35	22	19.9	153.0	1.8	6.499	0.49	22	23.2
110	20 000	112.3	1.3	4.769	0.30	24	15.8	135.0	1.6	5.701	0.40	25	19.0	158.2	1.9	6.722	0.53	25	22.3

Entering air at 10 °C

Sizes RTL/ RTH	Air flow (m ³ /h)	Water 70 - 50 °C						Water 80 - 60 °C						Water 90 - 70 °C					
		Heat. cap. (kW)	Water flow (kg/s)	Water flow (m ³ /h)	ΔP water (bar)	ΔP air (Pa)	T°C supply air	Heat. cap. (kW)	Water flow (kg/s)	Water flow (m ³ /h)	ΔP water (bar)	ΔP air (Pa)	T°C supply air	Heat. cap. (kW)	Water flow (kg/s)	Water flow (m ³ /h)	ΔP water (bar)	ΔP air (Pa)	T°C supply air
30	5500	35.5	0.4	1.511	0.24	8	28.9	44.0	0.5	1.829	0.31	8	33.5	53.2	0.6	2.239	0.45	8	38.4
40	7650	44.1	0.5	1.872	0.16	10	27.7	55.3	0.7	2.349	0.26	10	32.1	66.1	0.8	2.753	0.31	10	36.5
50	9200	47.8	0.6	2.001	0.20	13	25.9	60.0	0.7	2.516	0.30	13	30.0	72.6	0.9	3.071	0.40	13	34.2
60	11500	70.5	0.8	3.000	0.36	10	27.7	88.0	1.0	3.752	0.52	11	32.2	105.7	1.2	4.500	0.66	10	26.6
70	12500	72.9	0.9	3.071	0.41	12	27.0	91.5	1.1	3.896	0.57	12	31.3	109.7	1.3	4.700	0.77	12	25.5
80	16500	83.4	1.0	3.553	0.52	18	24.6	104.2	1.2	4.445	0.71	18	28.3	125.1	1.5	5.300	0.93	18	22.0
100	18500	87.6	1.0	3.721	0.24	21	23.7	109.6	1.3	4.669	0.32	21	27.2	131.6	1.6	5.600	0.45	21	20.7
110	20000	90.2	1.1	3.797	0.27	24	23.1	113.3	1.3	4.817	0.37	24	26.5	136.0	1.6	5.800	0.49	24	19.8

Entering air at 20 °C

Sizes RTL/ RTH	Air flow (m ³ /h)	Water 70 - 50 °C						Water 80 - 60 °C						Water 90 - 70 °C					
		Heat. cap. (kW)	Water flow (kg/s)	Water flow (m ³ /h)	ΔP water (bar)	ΔP air (Pa)	T°C supply air	Heat. cap. (kW)	Water flow (kg/s)	Water flow (m ³ /h)	ΔP water (bar)	ΔP air (Pa)	T°C supply air	Heat. cap. (kW)	Water flow (kg/s)	Water flow (m ³ /h)	ΔP water (bar)	ΔP air (Pa)	T°C supply air
30	5500	27.0	0.3	1.151	0.20	8	34.8	35.7	0.4	1.523	0.27	8	39.7	44.4	0.5	1.875	0.40	8	44.5
40	7650	33.3	0.4	1.403	0.12	10	33.8	44.5	0.5	1.895	0.22	10	38.4	55.6	0.7	2.365	0.25	10	43.0
50	9200	36.0	0.4	1.500	0.15	13	32.4	48.3	0.6	2.030	0.24	13	36.6	60.6	0.7	2.556	0.34	13	40.8
60	11500	53.7	0.6	2.279	0.34	10	34.0	71.0	0.8	3.025	0.50	10	38.5	88.4	1.0	3.764	0.64	11	43.0
70	12500	55.4	0.6	2.332	0.39	12	33.3	73.7	0.9	3.126	0.55	12	37.7	91.9	1.1	3.916	0.75	12	42.1
80	16500	63.5	0.8	2.709	0.50	18	31.6	84.1	1.0	3.582	0.68	18	35.3	104.1	1.2	4.331	0.90	18	38.9
100	18500	66.9	0.8	2.858	0.22	21	30.9	88.5	1.0	3.759	0.29	21	34.4	110.3	1.3	4.689	0.42	21	37.9
110	20000	68.9	0.8	2.918	0.47	24	30.4	91.5	1.1	3.884	0.64	24	33.8	114.3	1.3	4.869	0.88	24	37.2

Indoor Blower Performance - RoofT@ir 30 - Standard Fan

ADH 355

WHEEL DIAMETER

355 mm

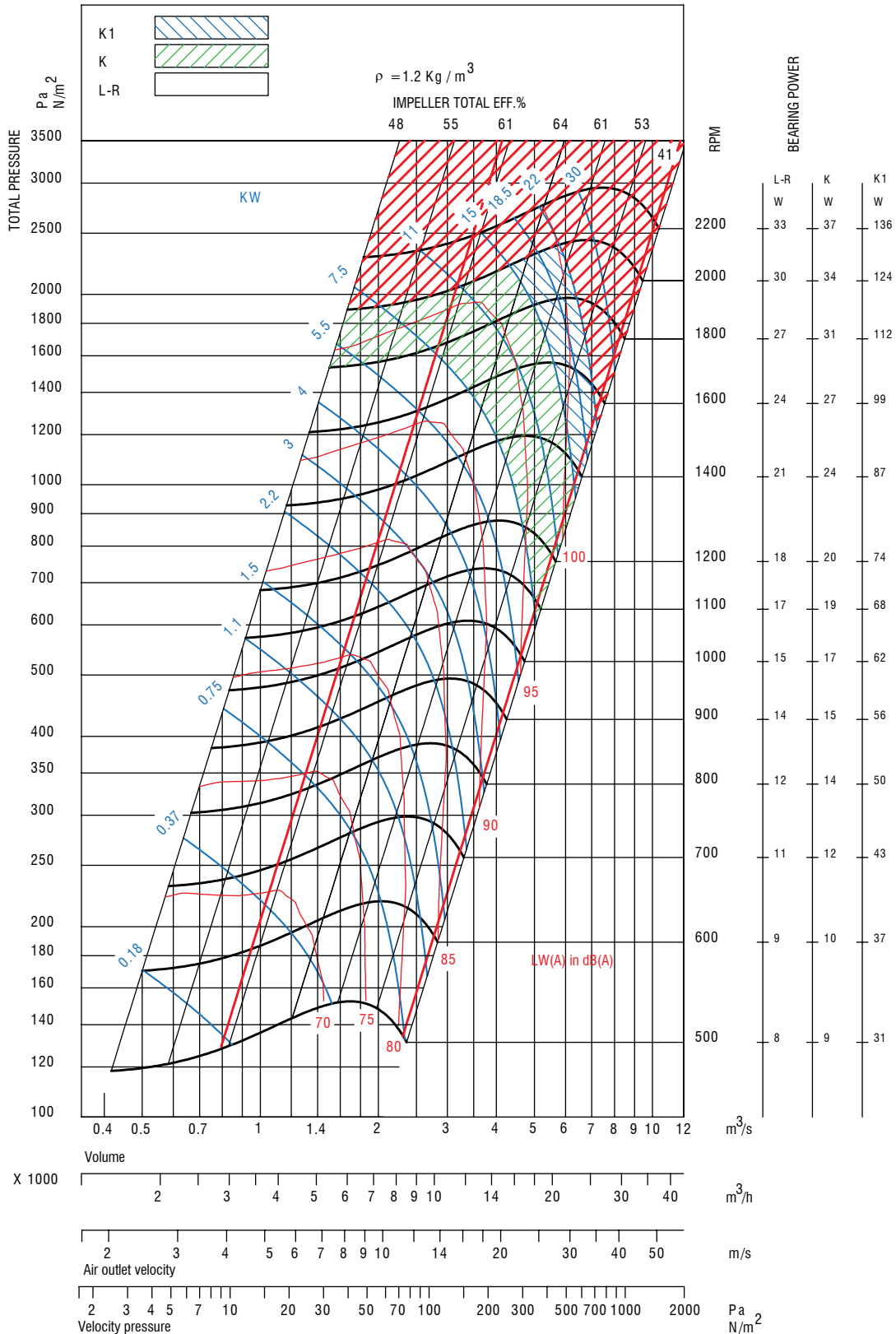

Performance shown is for installation type B, free inlet-ducted outlet, and doesn't include the effects of appurtenances in the airstream. Power rating kW doesn't include drive losses. The AMCA Certified Ratings Seal applies to air performance only.

Note : Components air pressure drops are not included in these curves.

Indoor Blower Performance - RoofT@ir 40 & 50 - Standard Fan

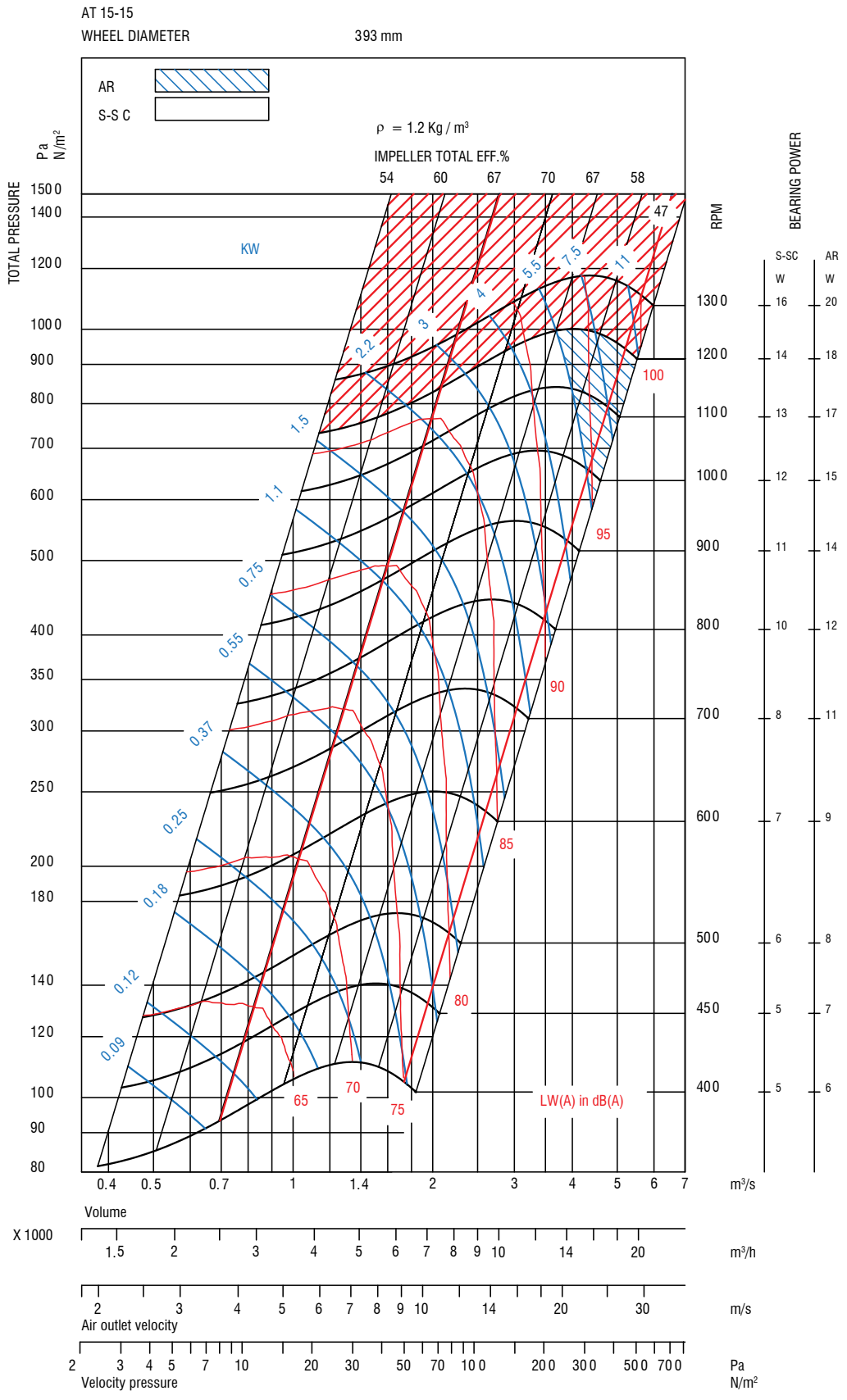

Performance shown is for installation type B, free inlet-ducted outlet, and doesn't include the effects of appurtenances in the airstream. Power rating kW doesn't include drive losses. The AMCA Certified Ratings Seal applies to air performance only.

Note : Components air pressure drops are not included in these curves.

Indoor Blower Performance - RoofT@ir 60 & 70 - Standard Fan

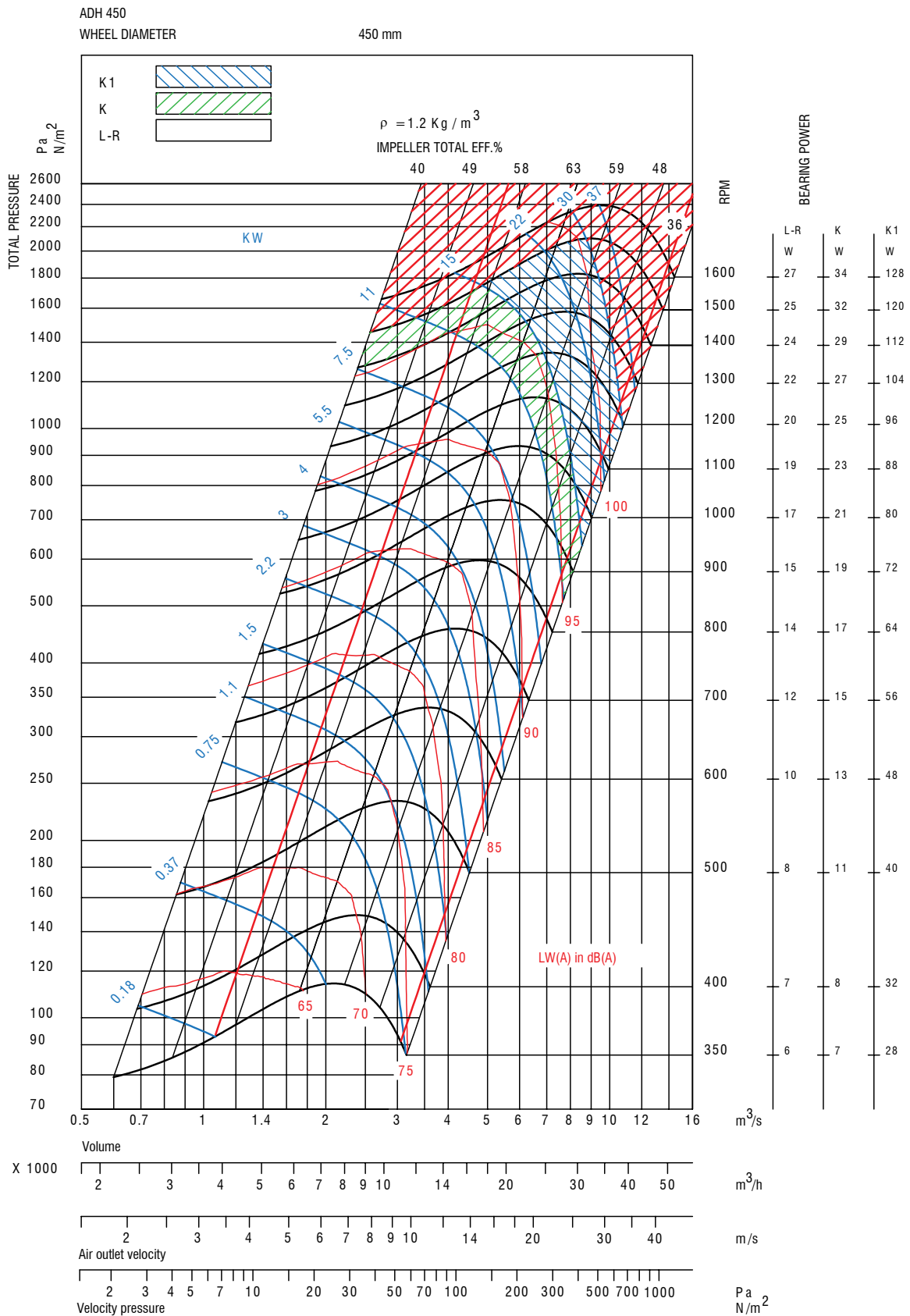

Performance shown is for installation type B, free inlet-ducted outlet, and doesn't include the effects of appurtenances in the airstream. Power rating kW doesn't include drive losses. The AMCA Certified Ratings Seal applies to air performance only.

Note : Components air pressure drops are not included in these curves.

Indoor Blower Performance - RoofT@ir 80 to 110 - Standard Fan

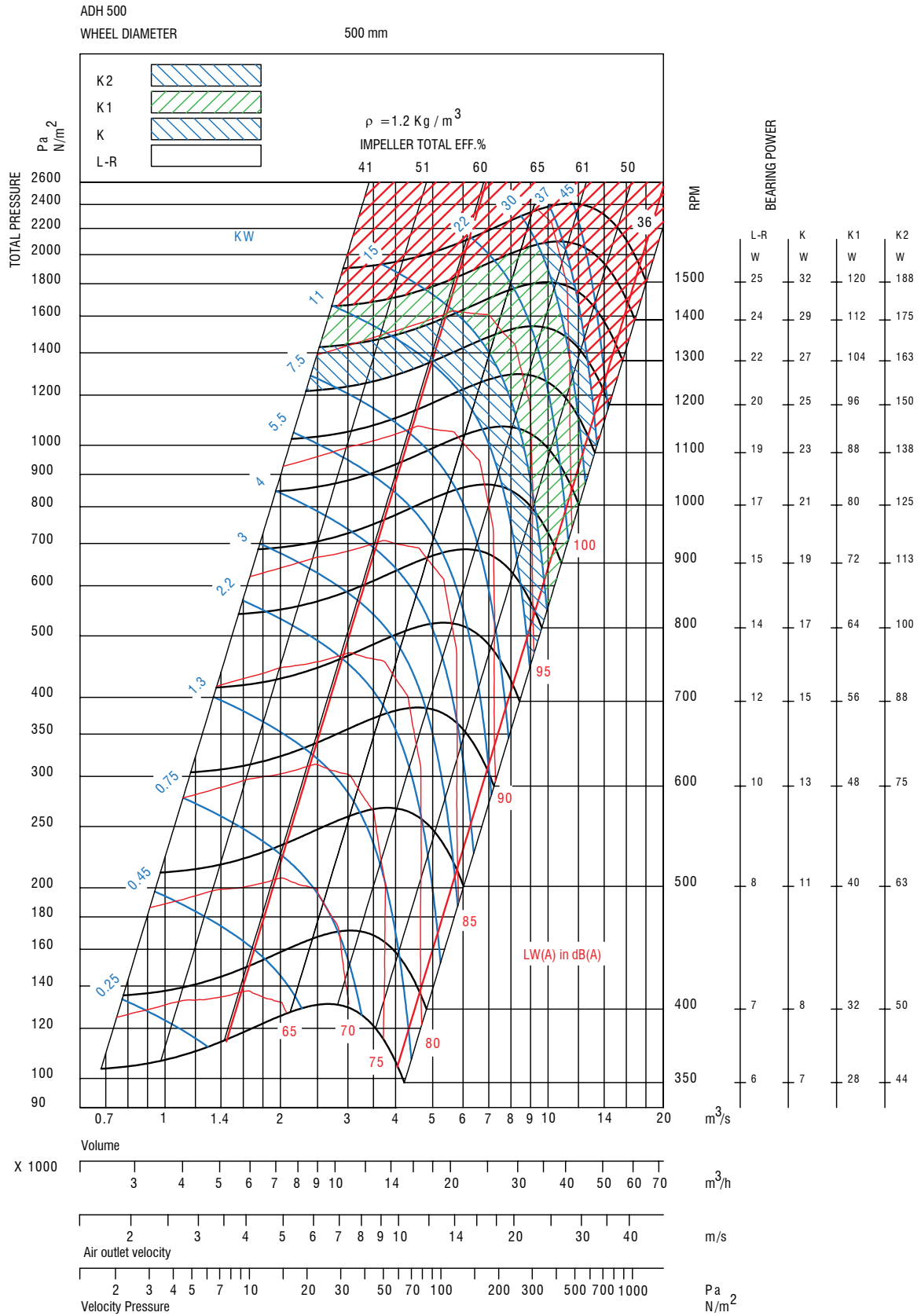

Performance shown is for installation type B, free inlet-ducted outlet, and doesn't include the effects of appurtenances in the airstream. Power rating kW doesn't include drive losses. The AMCA Certified Ratings Seal applies to air performance only.

Note : Components air pressure drops are not included in these curves.

Indoor Blower Performance - RoofT@ir 30 - High Pressure Fan (optional)

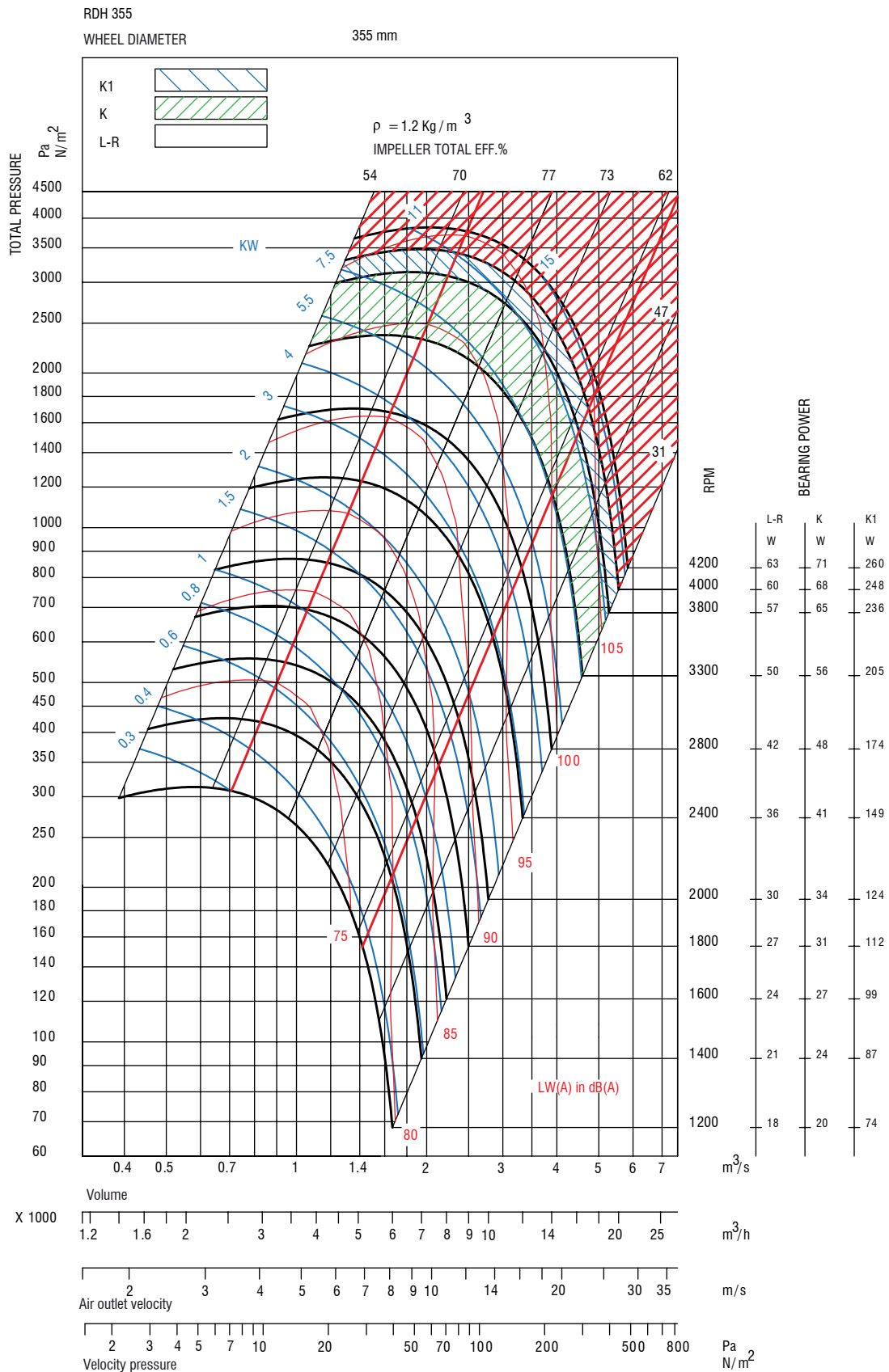

Performance shown is for installation type B, free inlet-ducted outlet, and doesn't include the effects of appurtenances in the airstream. Power rating kW doesn't include drive losses. The AMCA Certified Ratings Seal applies to air performance only.

Note : Components air pressure drops are not included in these curves.

Indoor Blower Performance - RoofT@ir 40 & 50 - High Pressure Fan (optional)

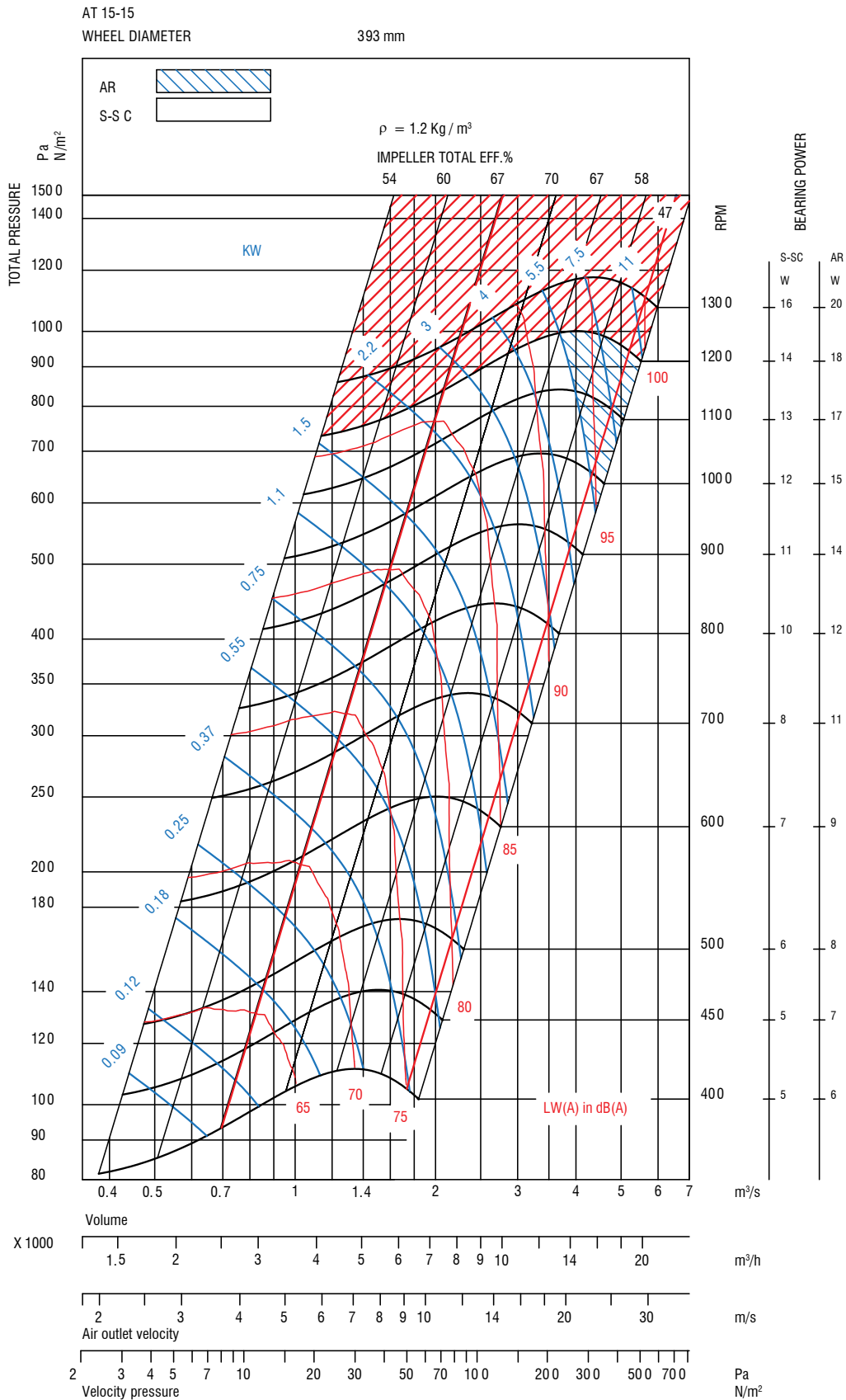

Performance shown is for installation type B, free inlet-ducted outlet, and doesn't include the effects of appurtenances in the airstream. Power rating kW doesn't include drive losses. The AMCA Certified Ratings Seal applies to air performance only.

Note : Components air pressure drops are not included in these curves.

Indoor Blower Performance - RoofT@ir 60 & 70 - High Pressure Fan (optional)

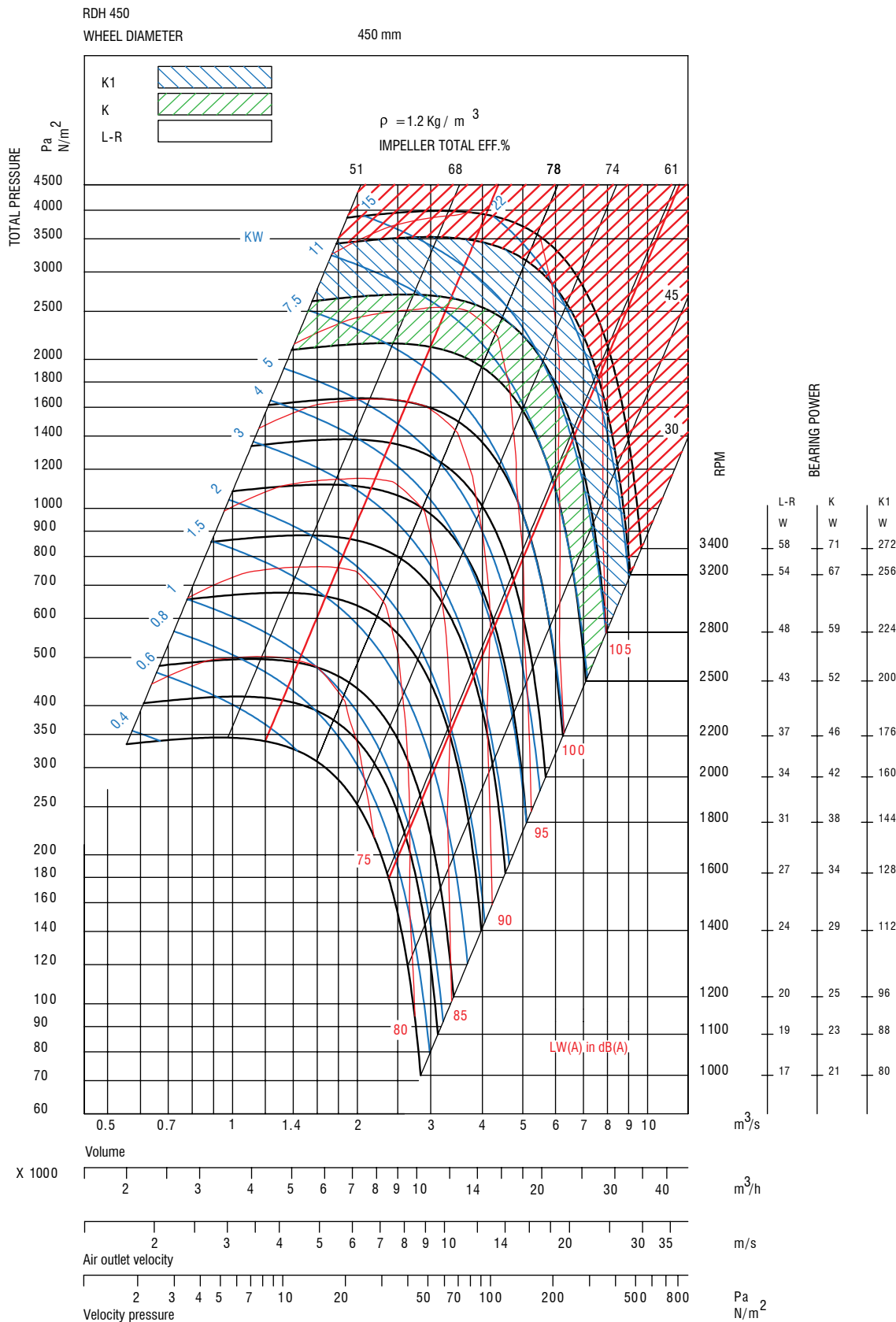

Performance shown is for installation type B, free inlet-ducted outlet, and doesn't include the effects of appurtenances in the airstream. Power rating kW doesn't include drive losses. The AMCA Certified Ratings Seal applies to air performance only.

Note : Components air pressure drops are not included in these curves.

Indoor Blower Performance - RoofT@ir 80 to 110 - High Pressure Fan (optional)

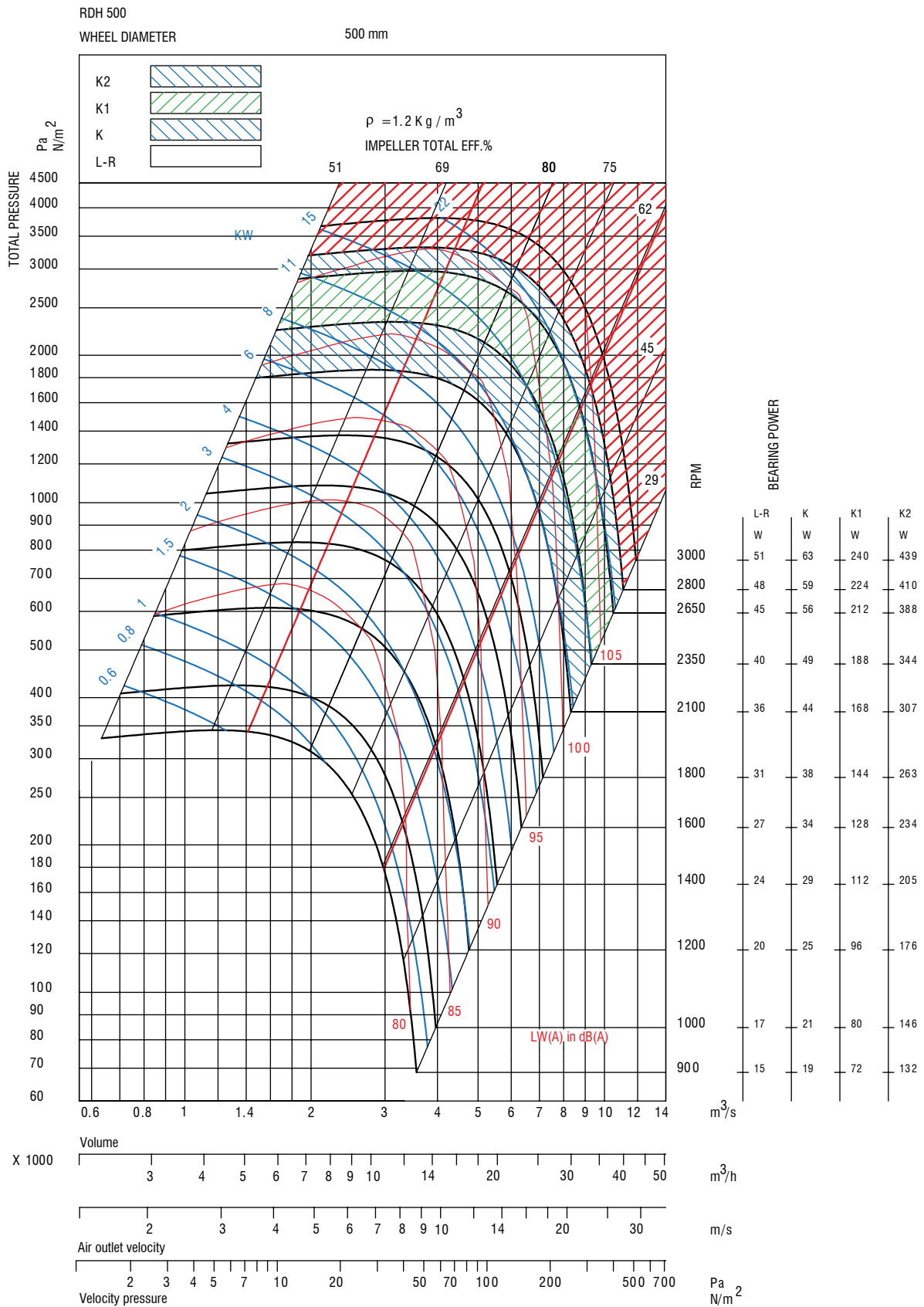

Performance shown is for installation type B, free inlet-ducted outlet, and doesn't include the effects of appurtenances in the airstream. Power rating kW doesn't include drive losses. The AMCA Certified Ratings Seal applies to air performance only.

Note : Components air pressure drops are not included in these curves.

Components Air Pressure Drop

Filter G4

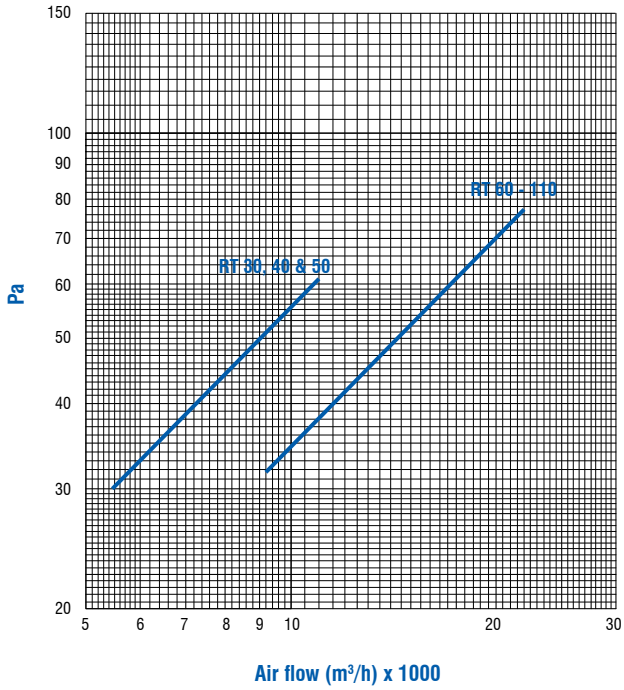

Filter F6

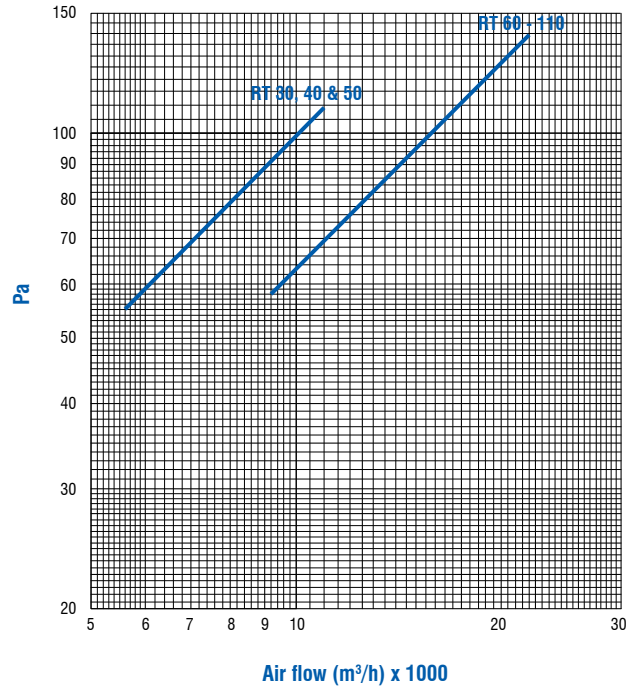

Economizer

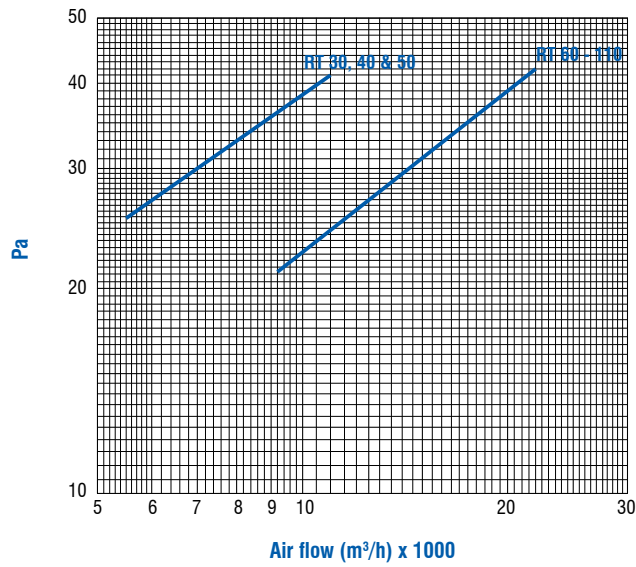

Components Air Pressure Drop (continued)

Electric heater - CH1

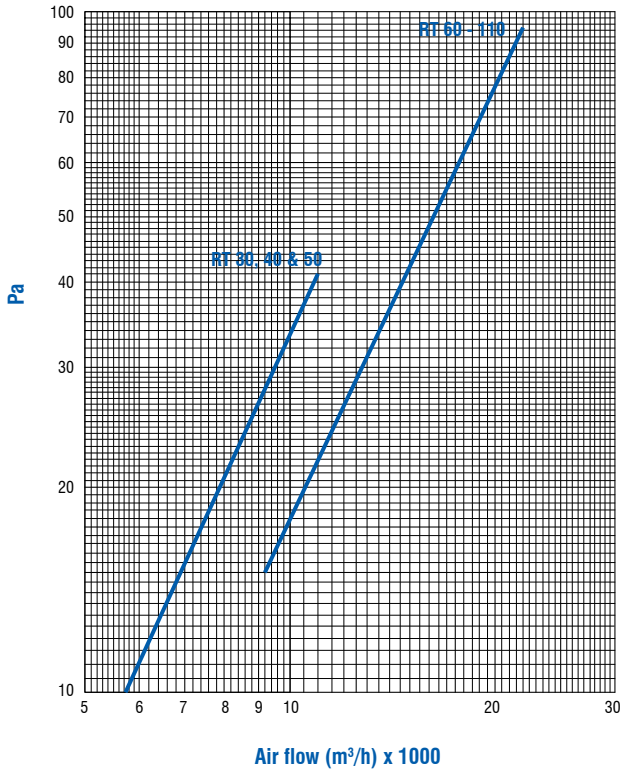

Electric heater - CH2

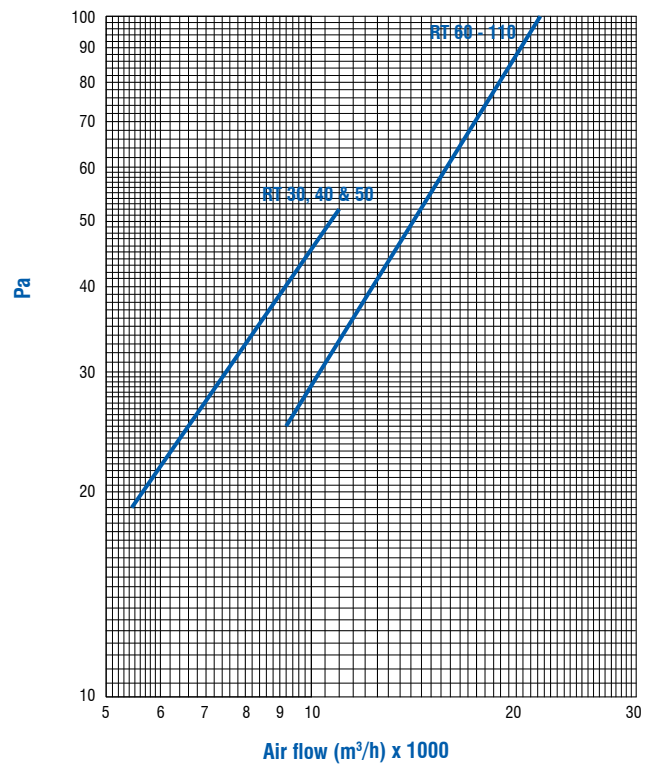

Roof curb

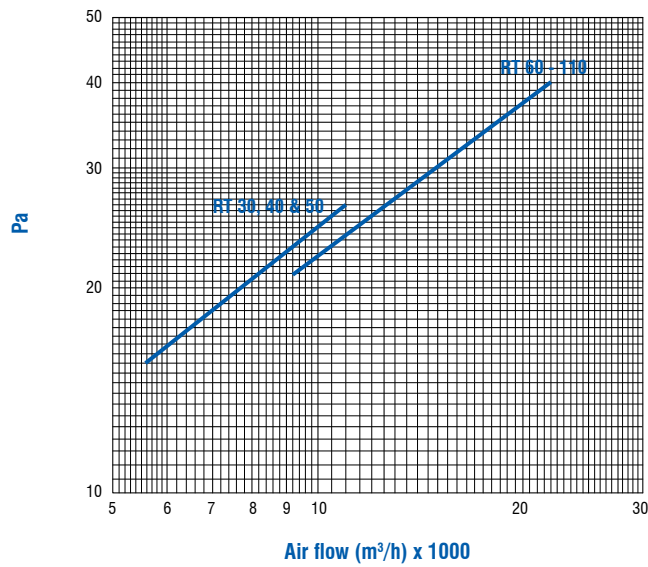

Dimensions (mm) - RTL/RTH 30 to 50

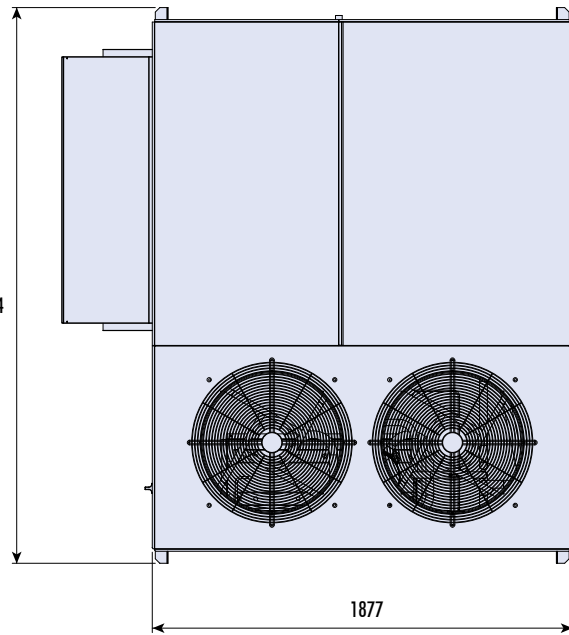
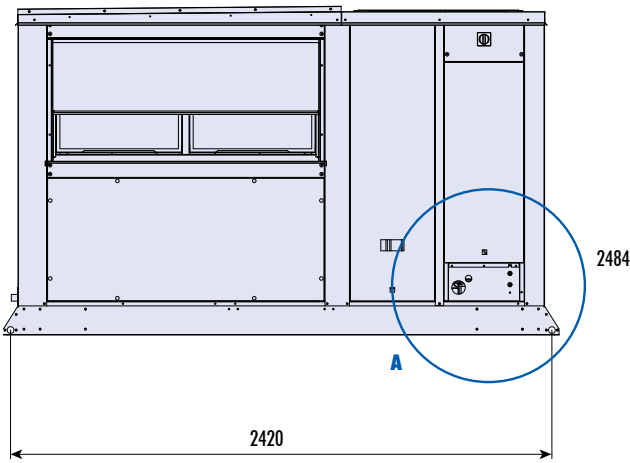
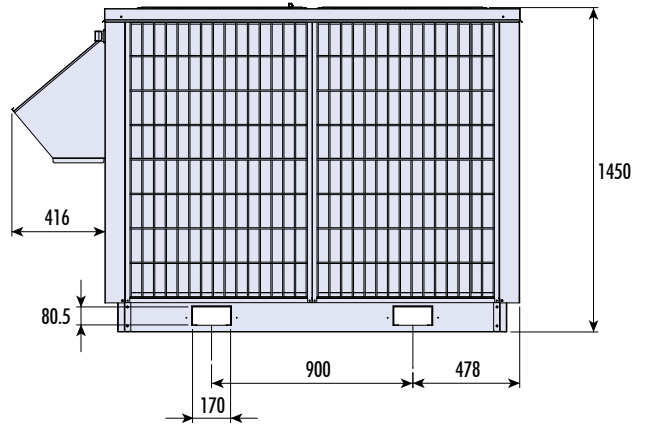
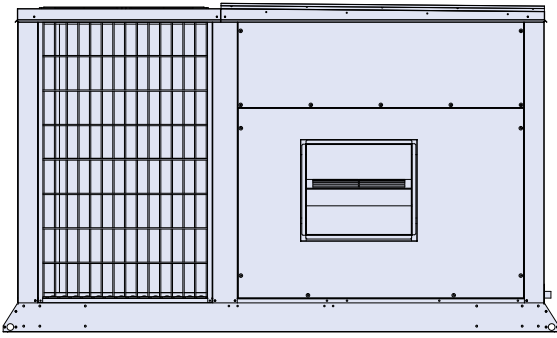

Hot Water

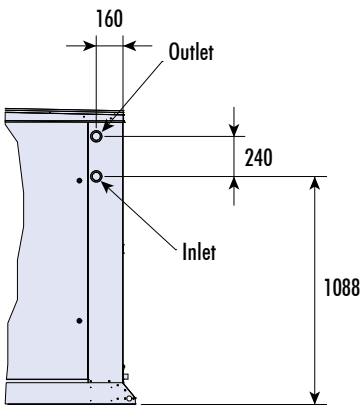

Detail A

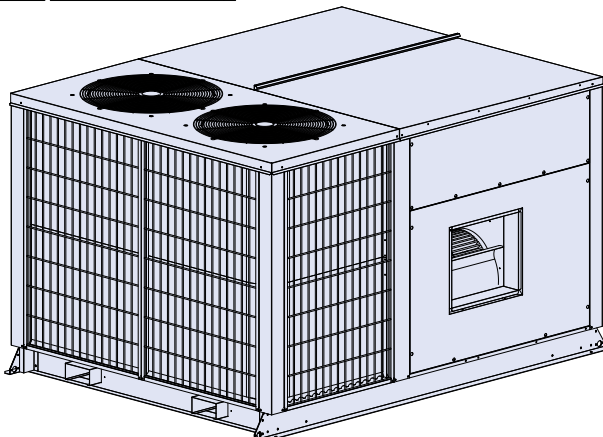
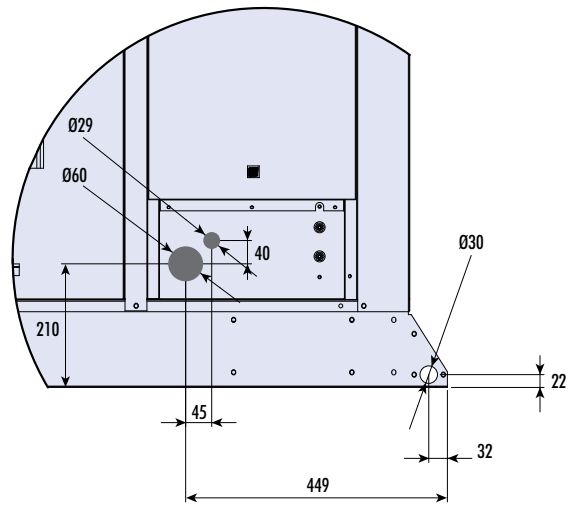

Dimensions (mm) - RTL/RTH 60 to 80

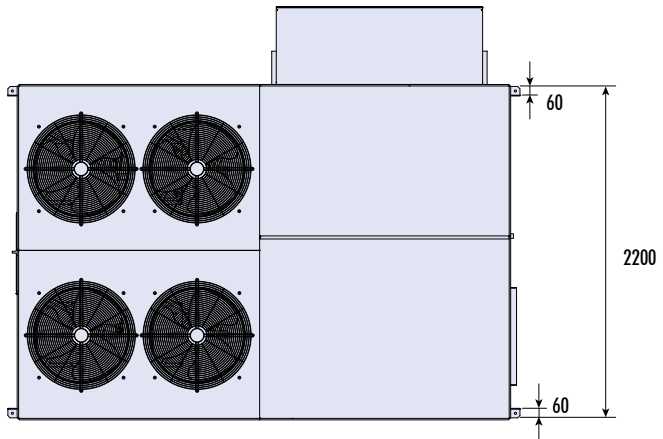
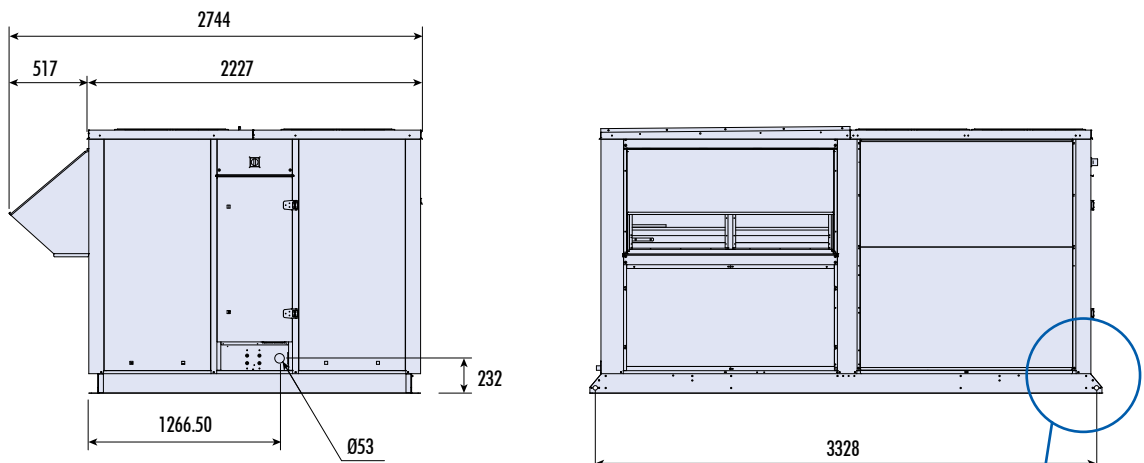
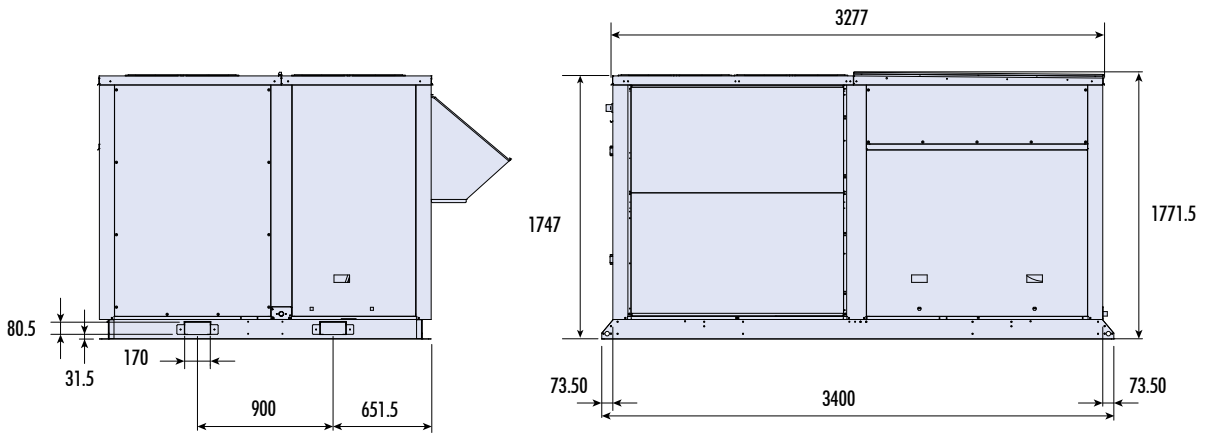

Hot Water

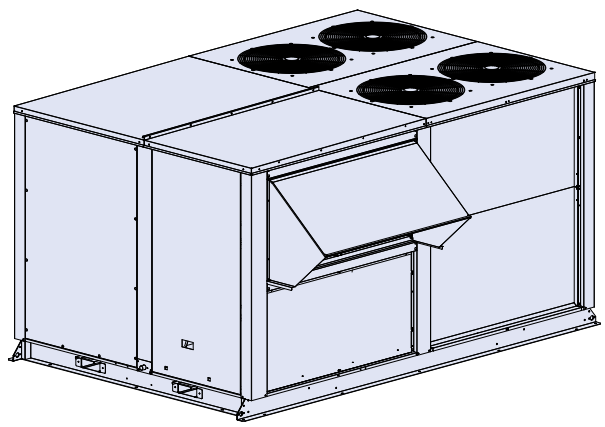
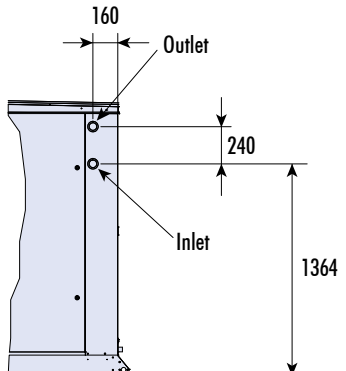

Dimensions (mm) - RTL/RTH 100 & 110

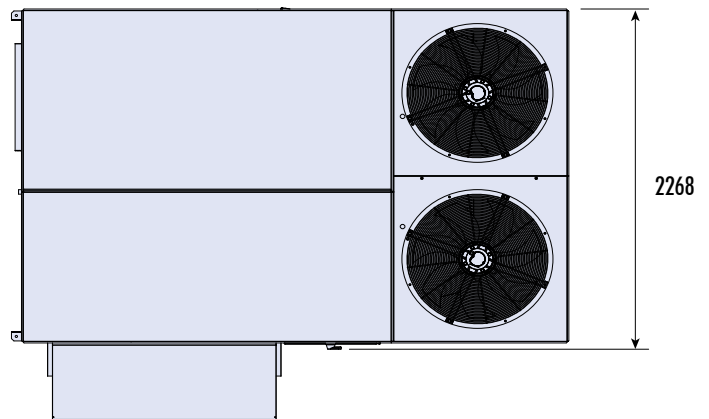
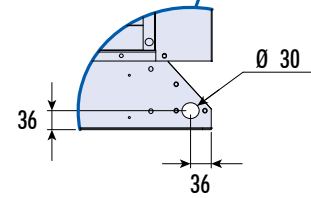
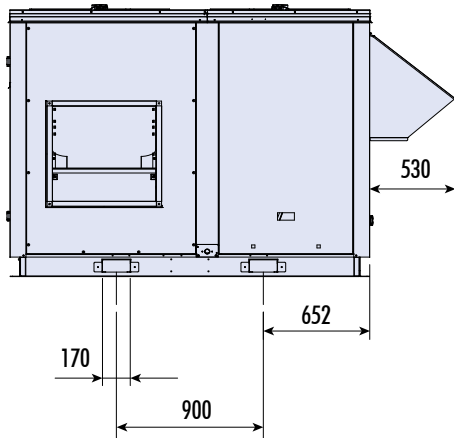
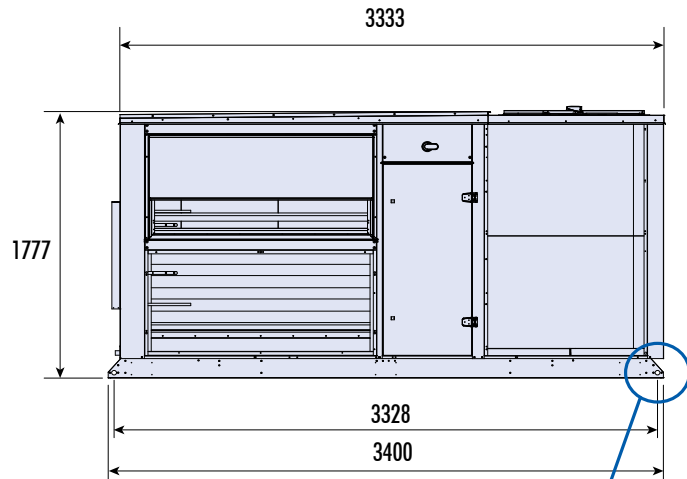
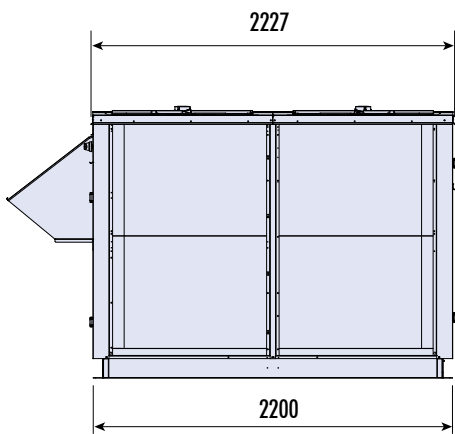

Hot Water

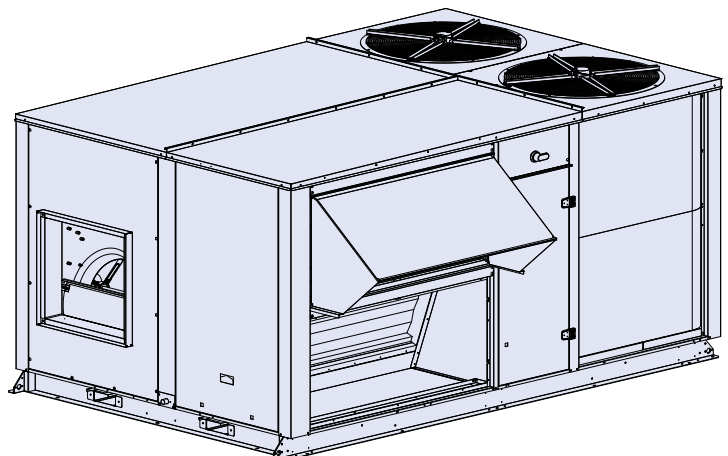
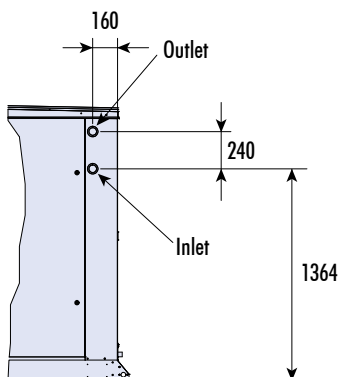

Supply Air Arrangements

S1 - Down supply

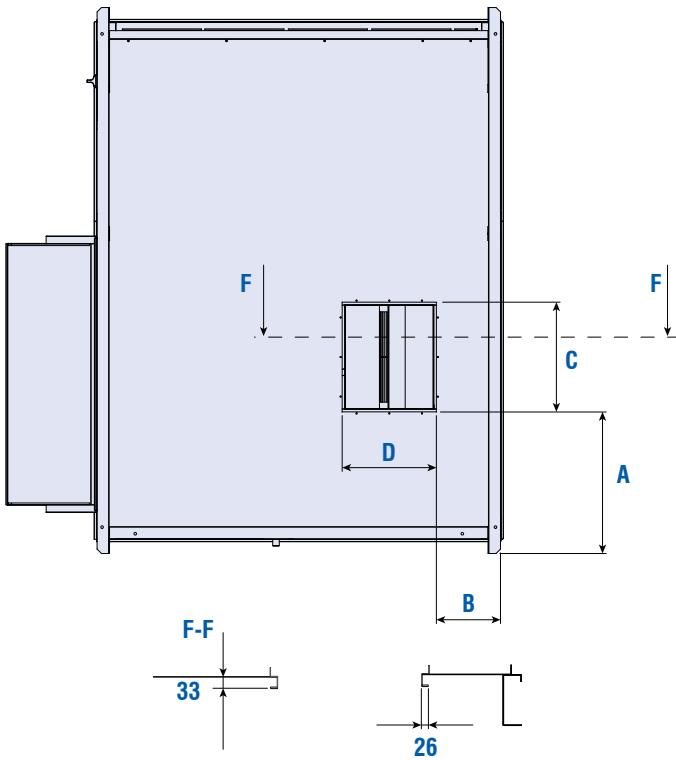

RTL/RTH	30	40-50	60-70	80-100-110
A	668.5	645.5	737	738
B	296	295	325	328
C	453	497	574	641
D	453	430	574	641

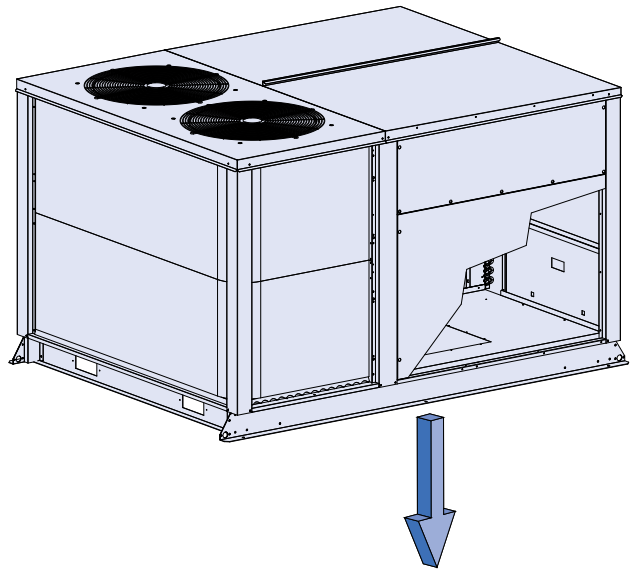

S2 - Side supply

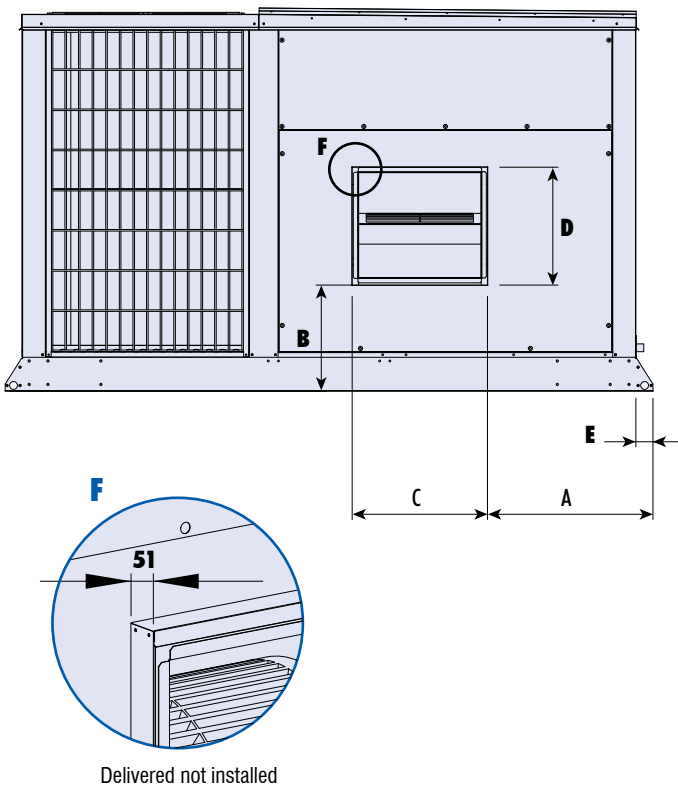

RTL/RTH	30	40-50	60-70	80-100-110
A	593	528	627	705
B	391	365	434	460
C	601	601	648	715
D	537	534	648	715
E	65.5	65.5	73.5	73.5

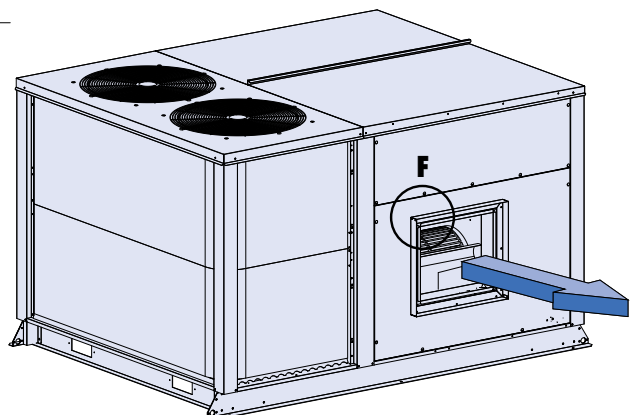

Supply Air Arrangements (continued)

S3 - Front supply

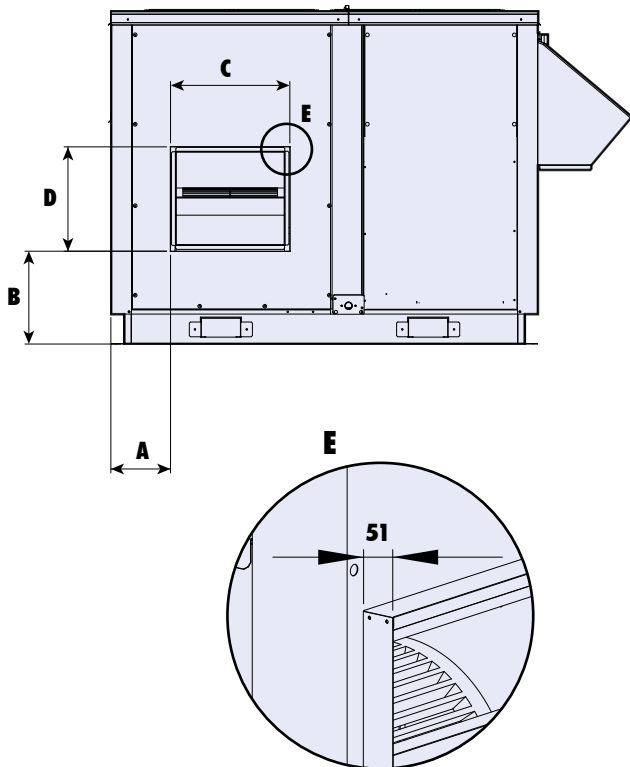

RTL/ RTH	30		40-50		60-70		80-100-110	
		Hot water		Electric heater		Electric heater		Electric heater
A	158	122	122	158	219	219	219	219
B	321	360	360	321	436	460	460	460
C	714	601	601	714	648	715	715	715
D	612	534	534	612	648	715	715	715

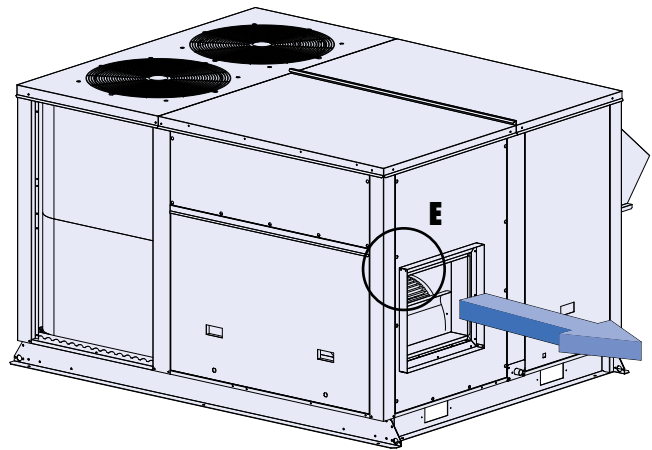

S4 - Top supply

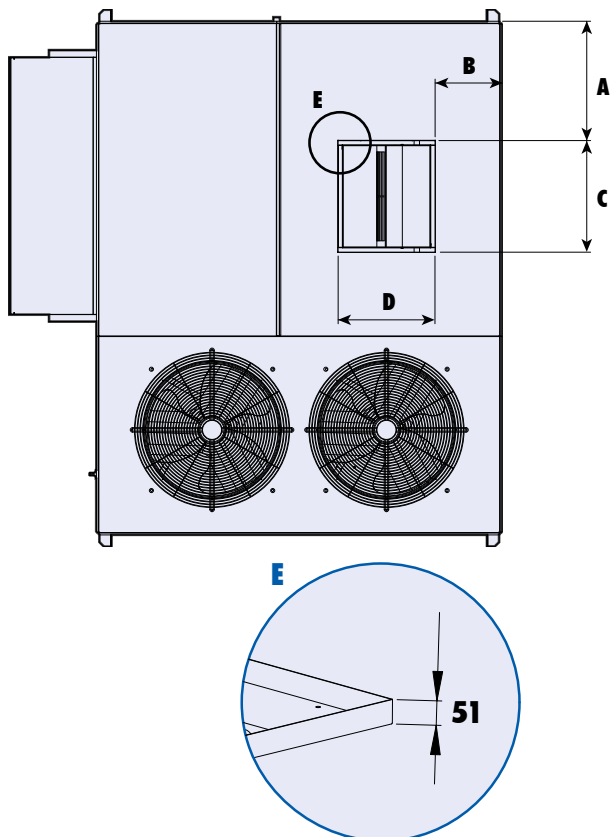

RTL/RTH	30	40-50	60-70	80-100-110
A	562	530	630	632
B	290	258	330	263
C	601	601	648	715
D	534	534	648	715

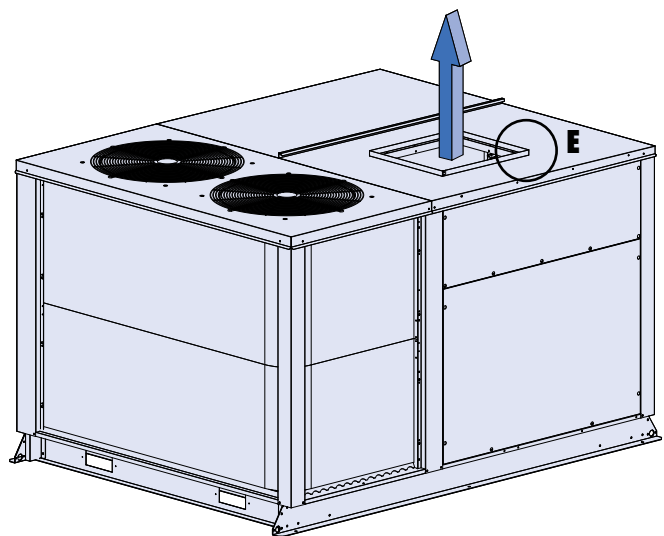

Return Air Arrangements

R1 - Down return

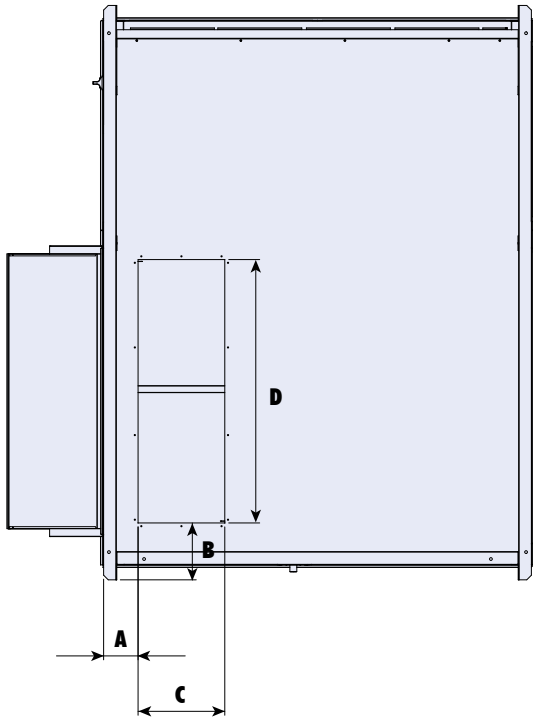

RTL/RTH	30 to 50	60 to 110
A	157	142
B	220	249
C	310	485
D	1181	1358

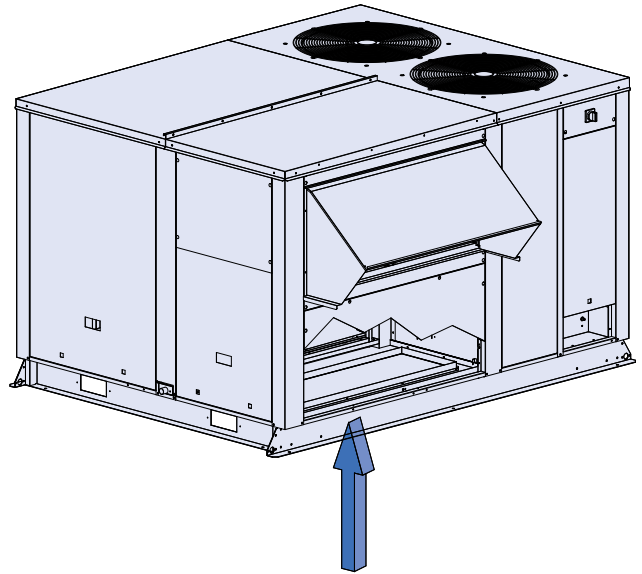

R2 - Side return

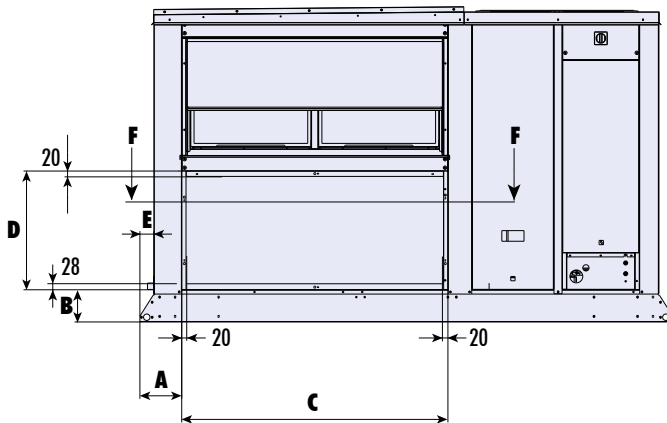

RTL/RTH	30 to 50	60 to 110
A	195	150
B	150	150
C	1241	1420
D	553,5	703,5
E	65,5	73,5

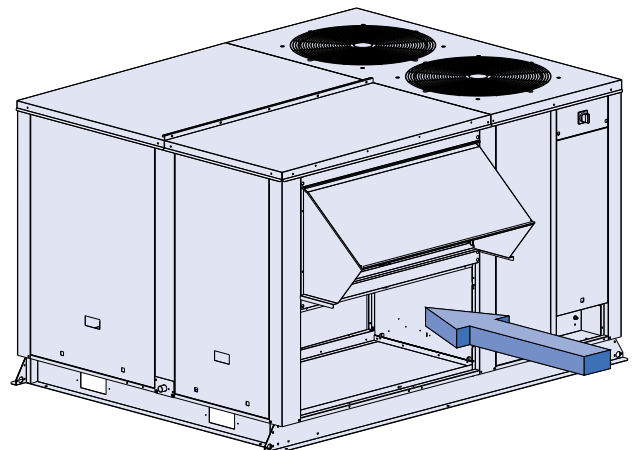

Return Air Arrangements (continued)

R3 - Front return

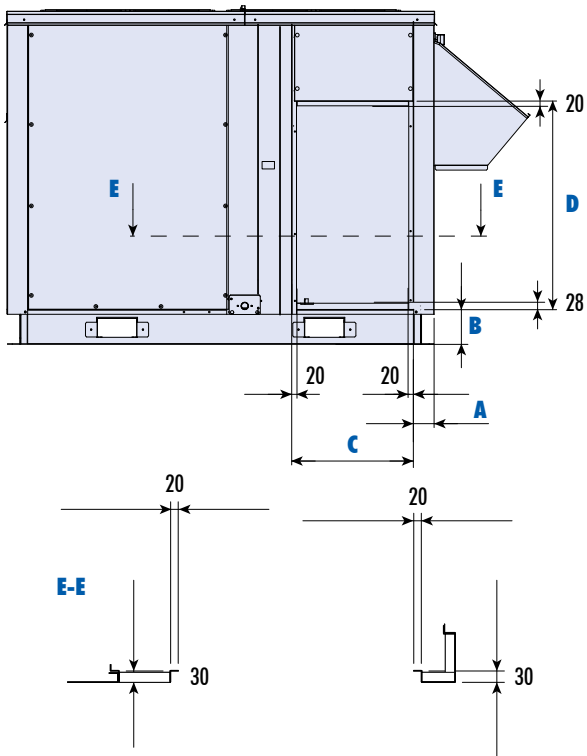

RTL/RTH	30 to 50	60 to 110
A	90	100
B	150	150
C	412	514,5
D	892	1352

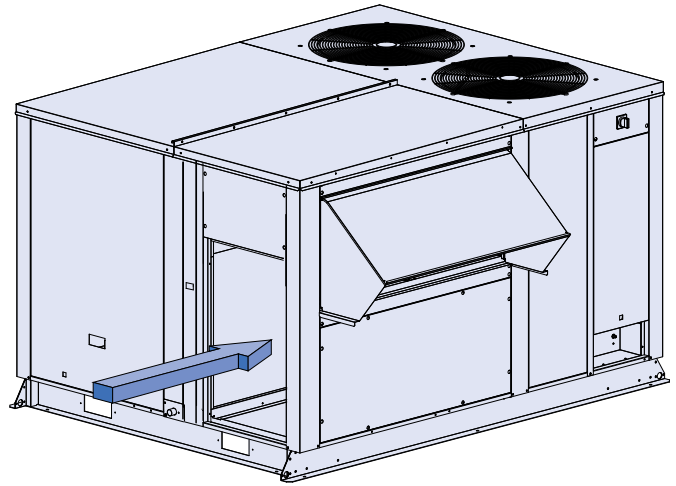

R4 - Top return

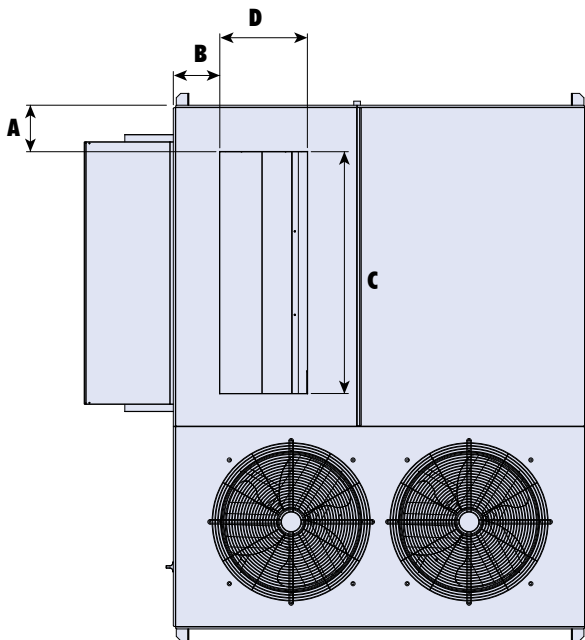

RTL/RTH	30 to 50	60 to 110
A	180	180
B	40	40
C	1139	1359
D	439	532

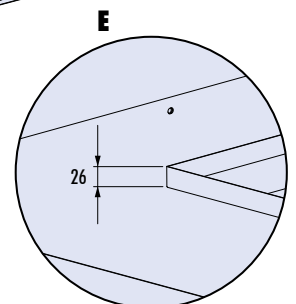
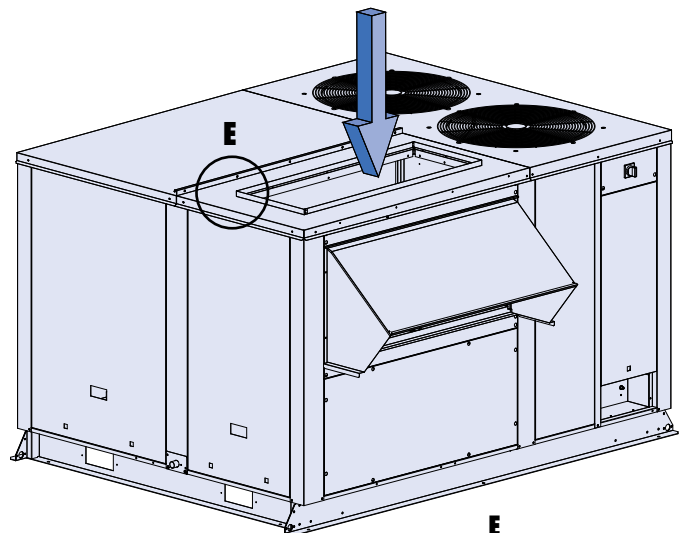

Dimensions (mm) - Exhaust Blower

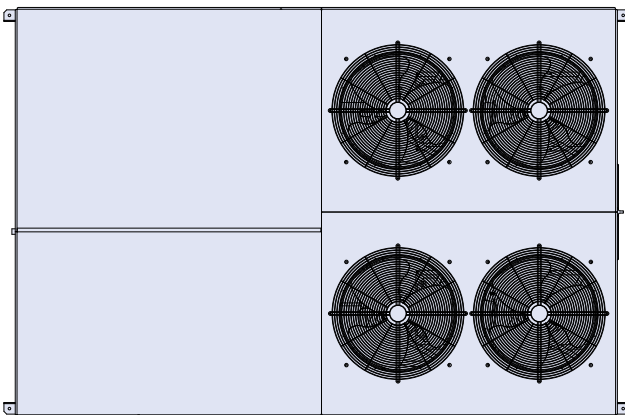
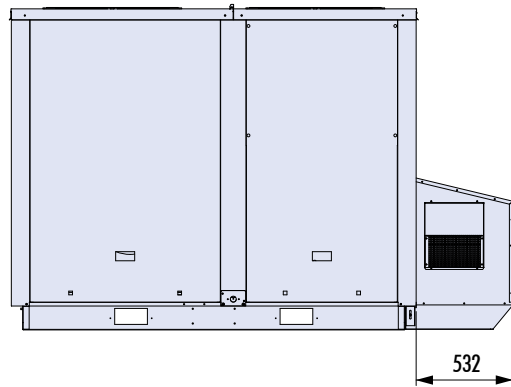
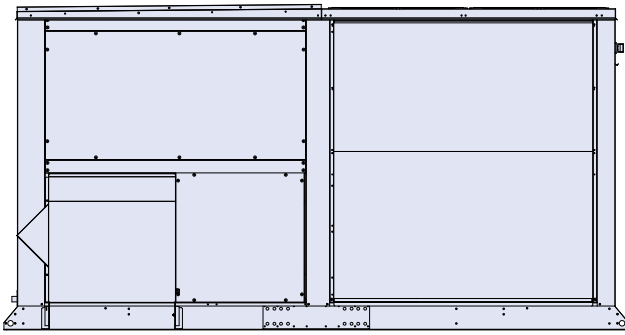

RTL/RTH	30 to 50	60 to 110
A	642	690
B	828	910

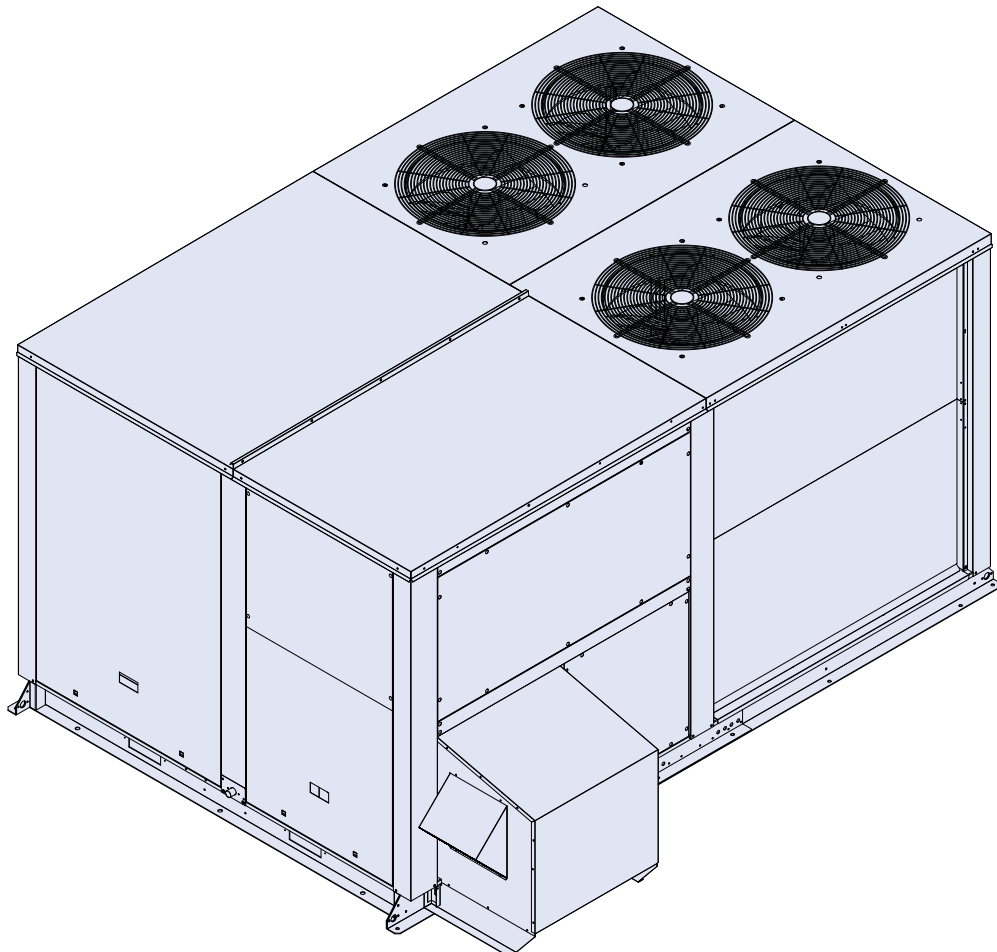
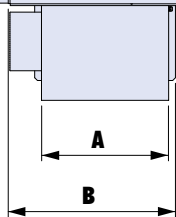

Ground Mounting Dimensions (mm)

RTL/RTH 30 to 50

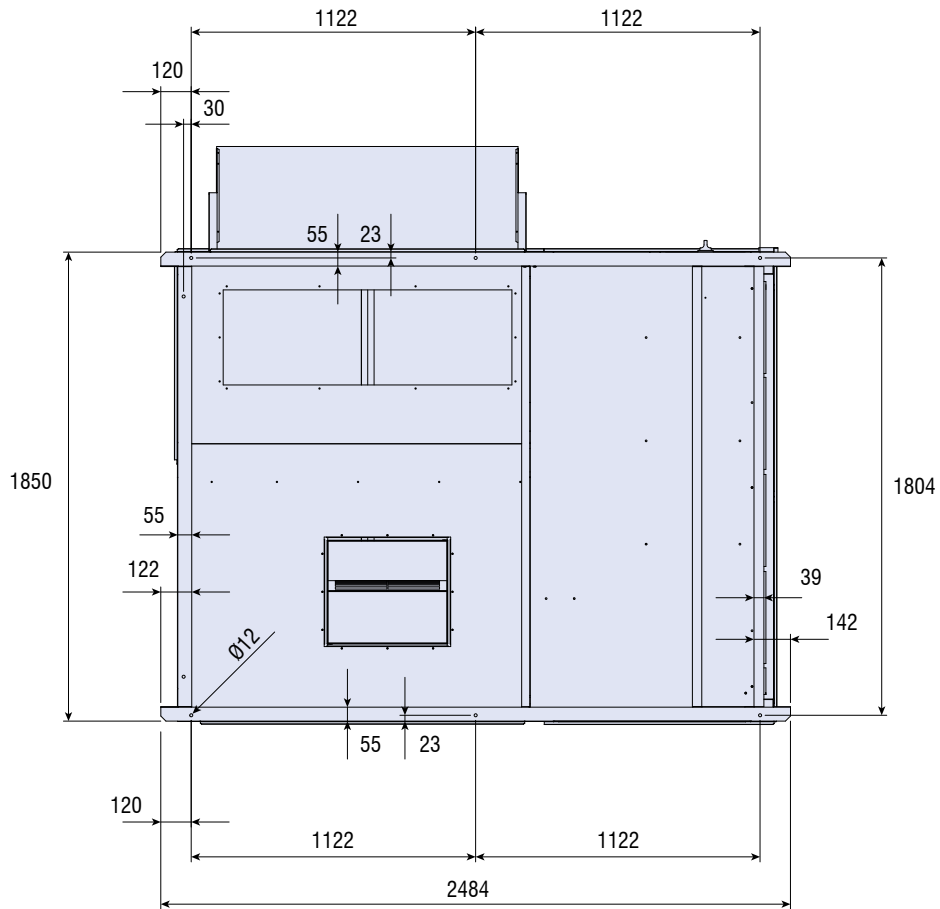

RTL/RTH 60 to RTL/RTH 110

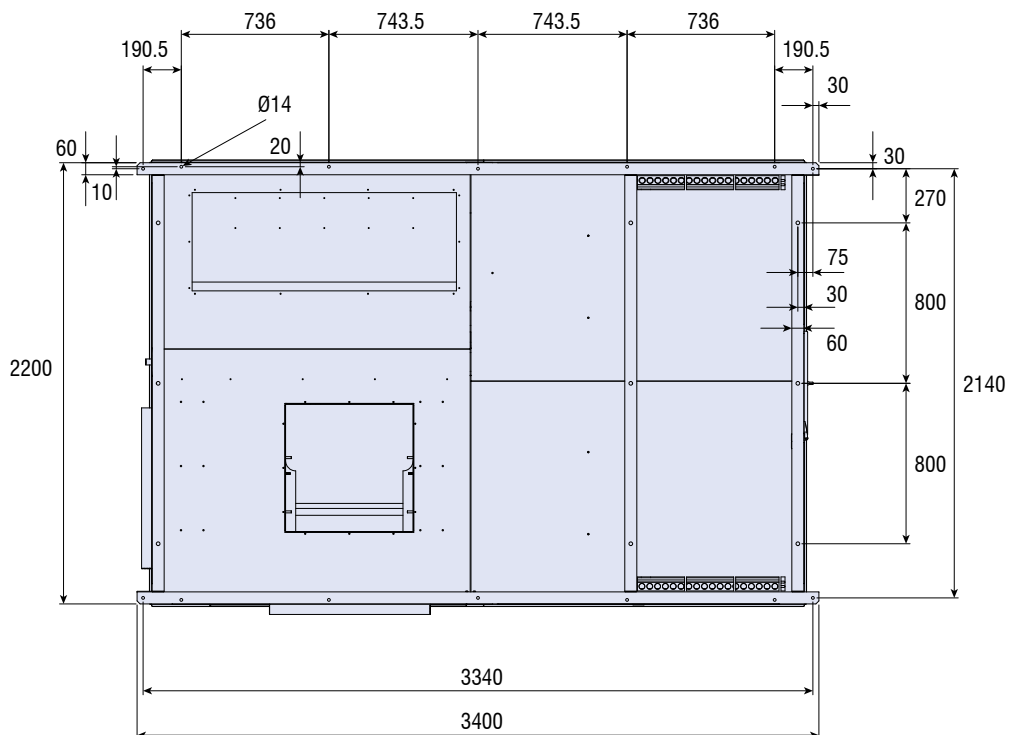

Roof Curb Dimensions (mm)

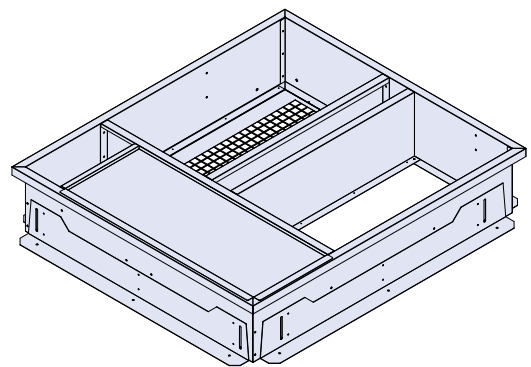
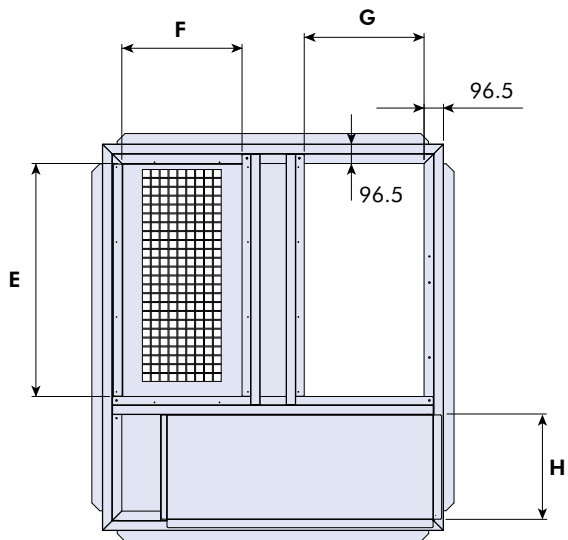
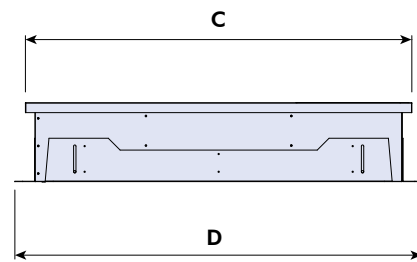
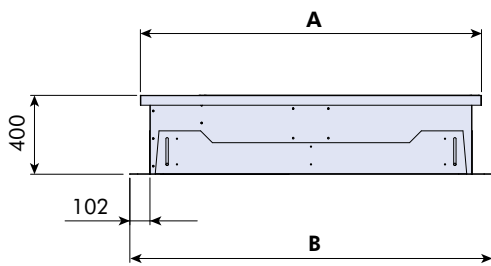

RTL/RTH	A	B	C	D	E	F	G	H
30-40-50	1726	1837	1956	2069	1182	610	608	536
60-70-80-100-110	2061	2172	2273	2384	1458	579	834	573

Adjustable version

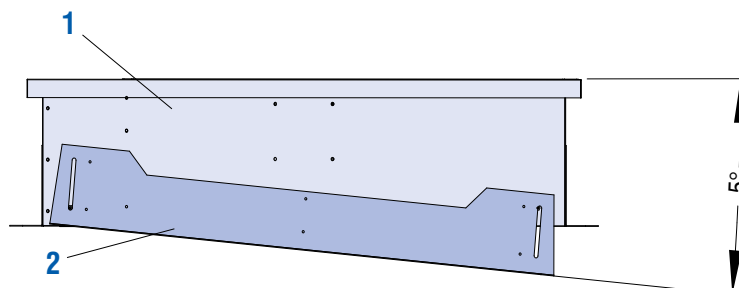

Rigidly weld part 2 to part 1 to ensure a rigid single-piece assembly

Roof Curb Mounting - Sizes 30 to 50

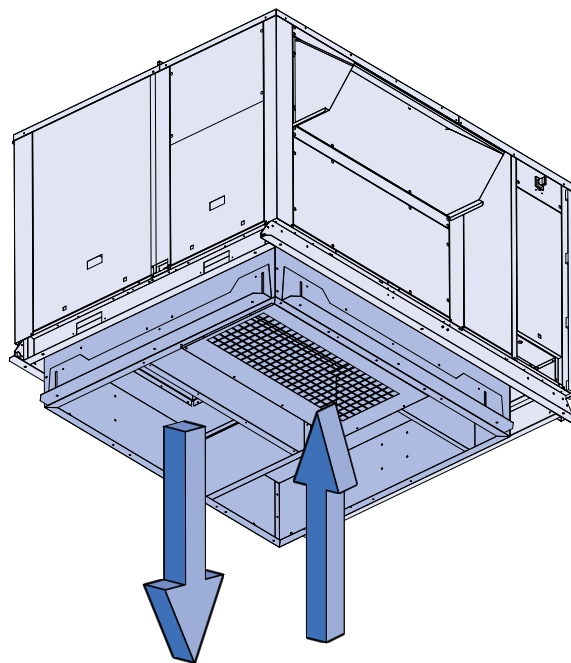
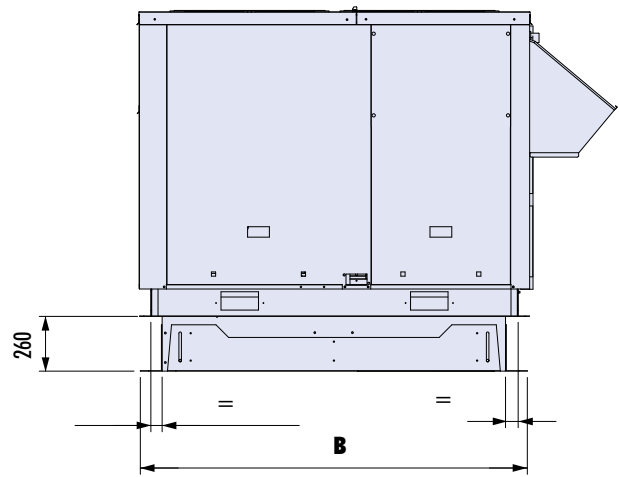
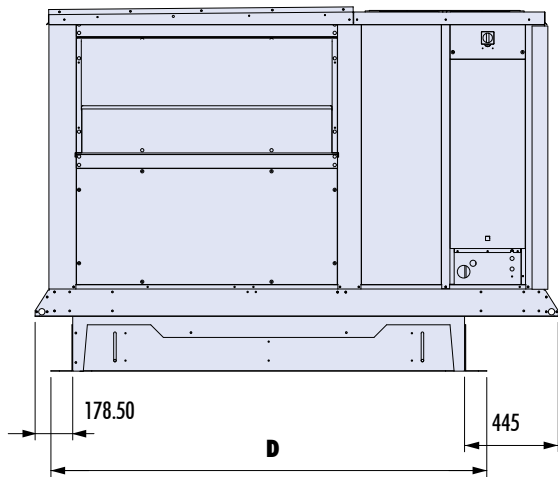
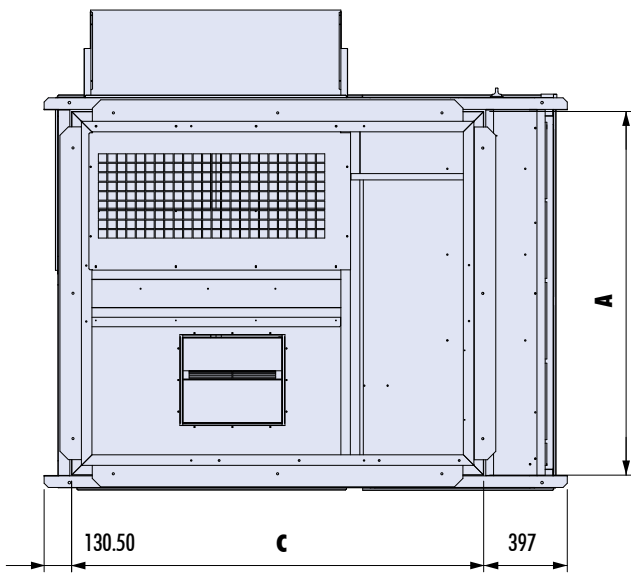

AIR SUPPLY **AIR RETURN**

Roof Curb Mounting - Sizes 60 to 110

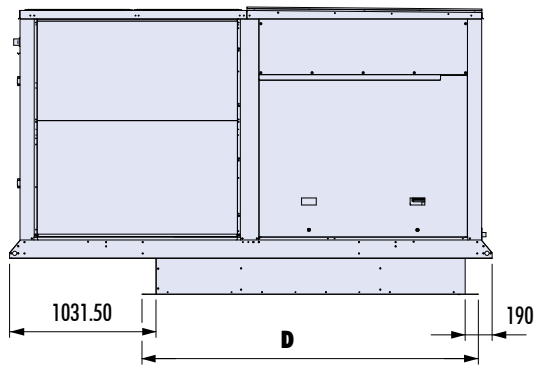
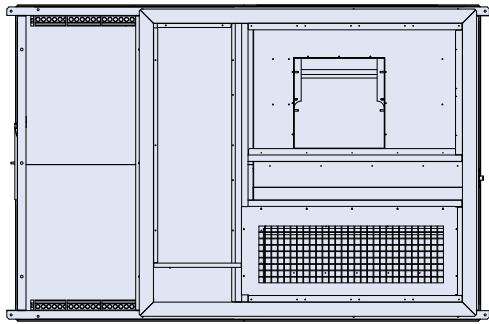

Sizes 60 to 80

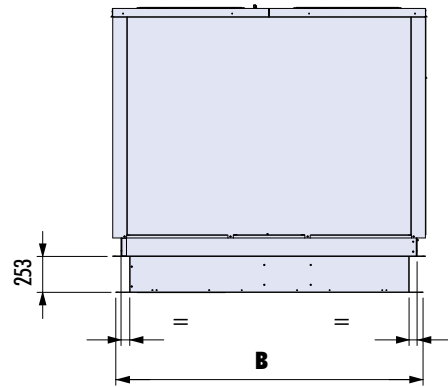

Sizes 100 and 110

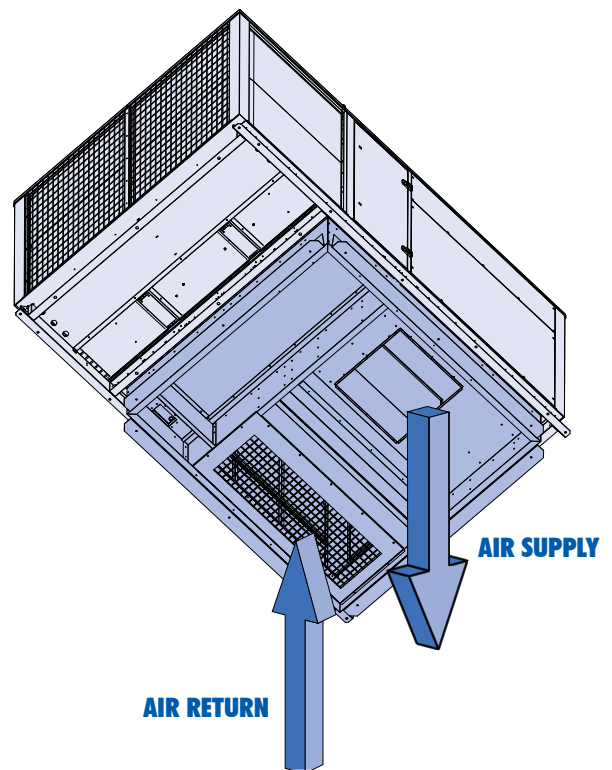
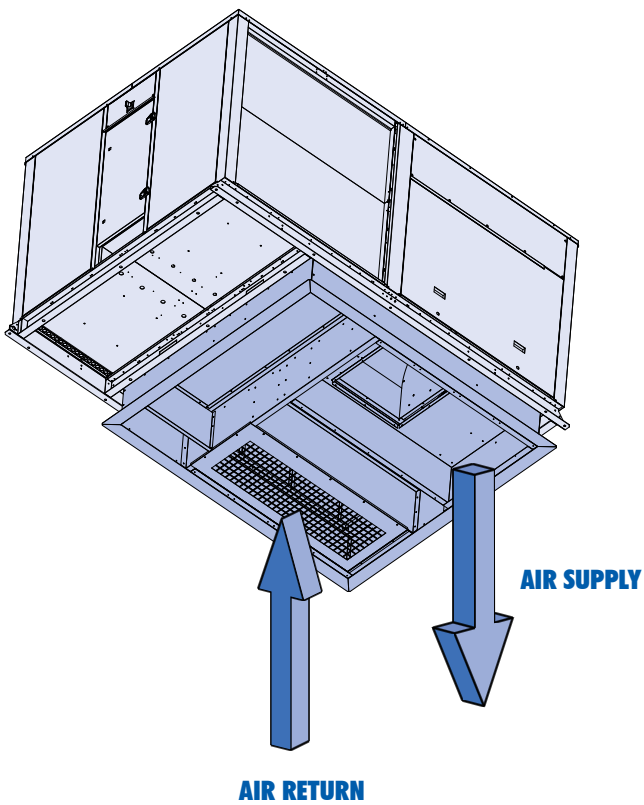

ERP Roof Curb Dimensions (mm) - RTL/RTH 30 to 50

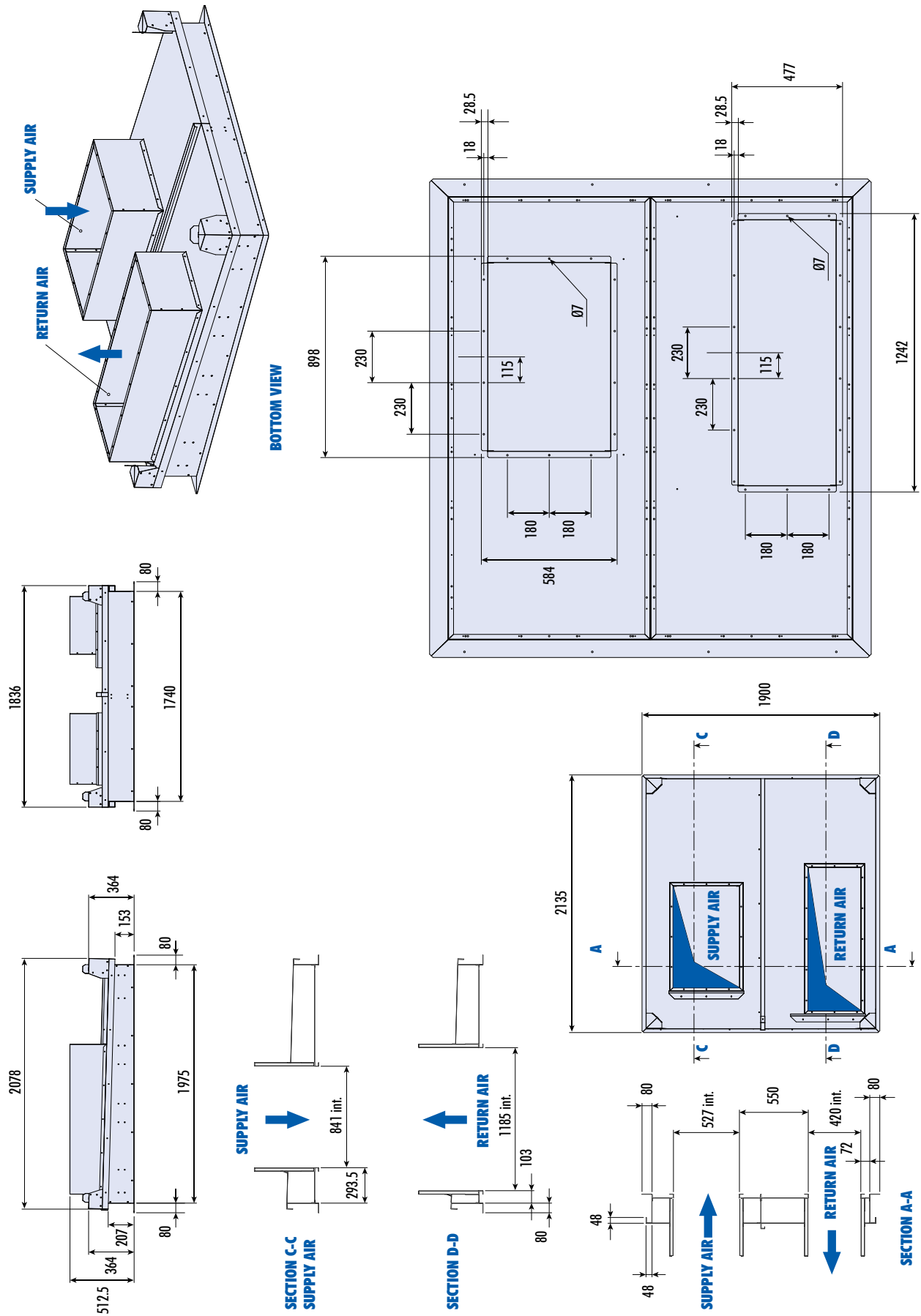

ERP Roof Curb Mounting (mm) - RTL/RTH 30 to 50

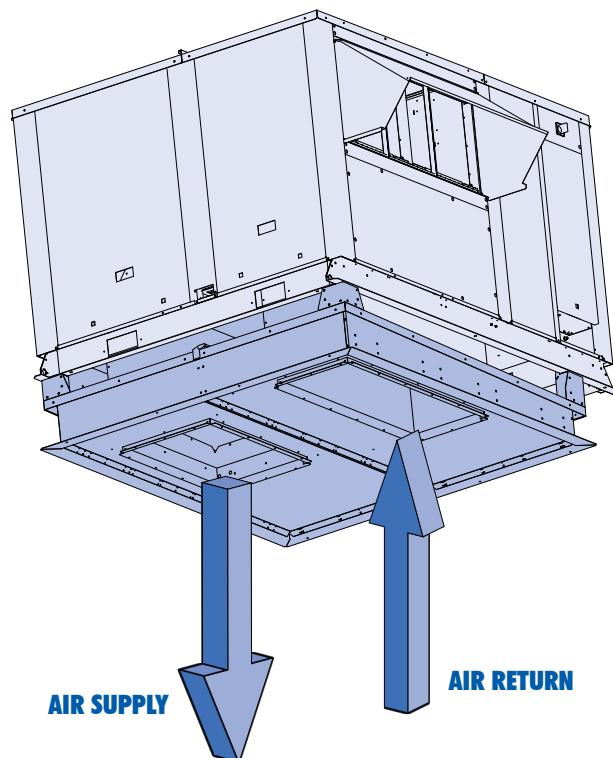
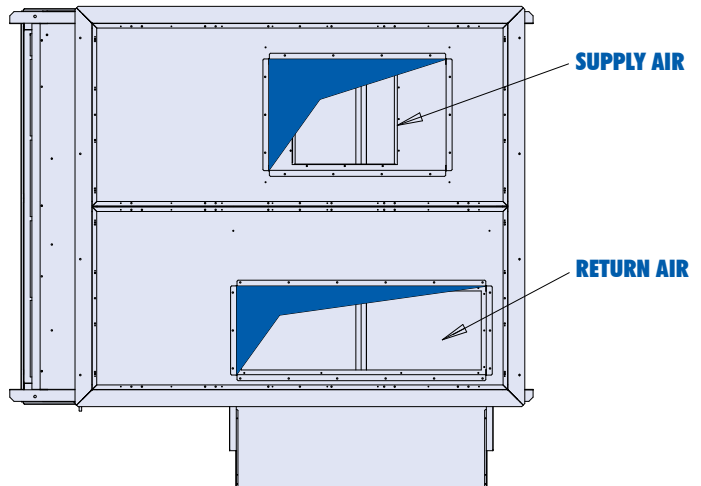
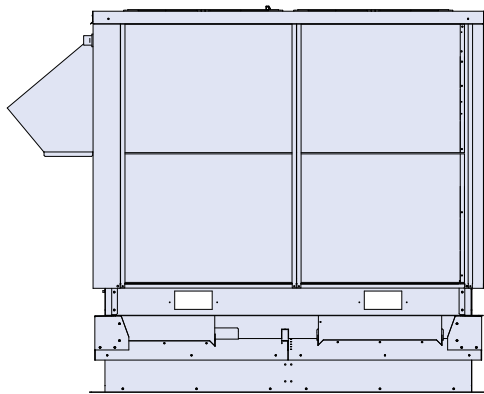
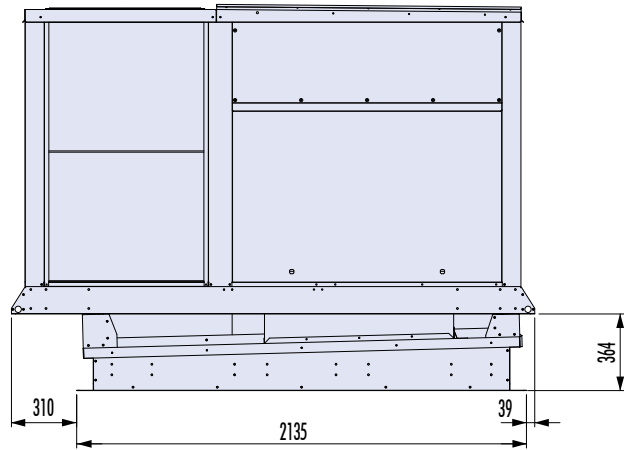
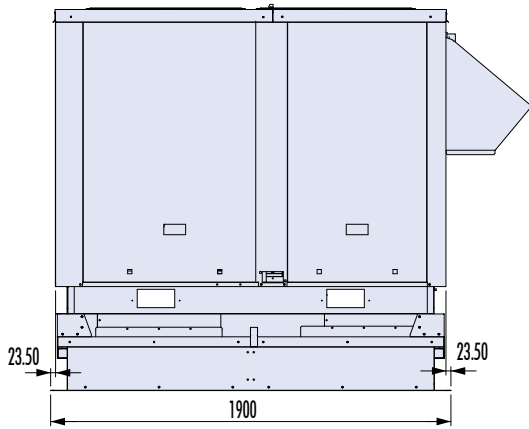

ERP Roof Curb Dimensions (mm) - RTL/RTH 60 to 110

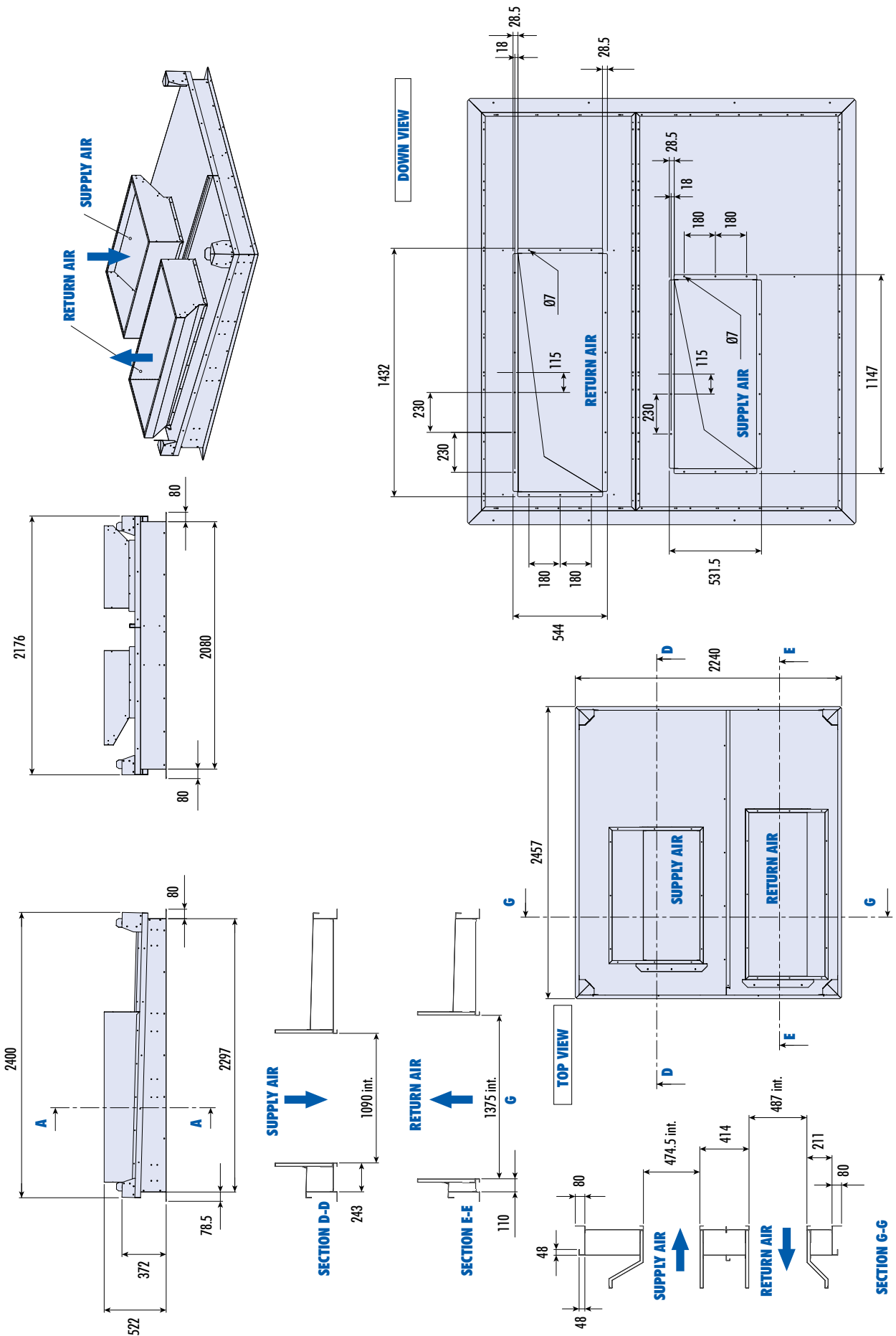

ERP Roof Curb Dimensions (mm) - RTL/RTH 60 to 110

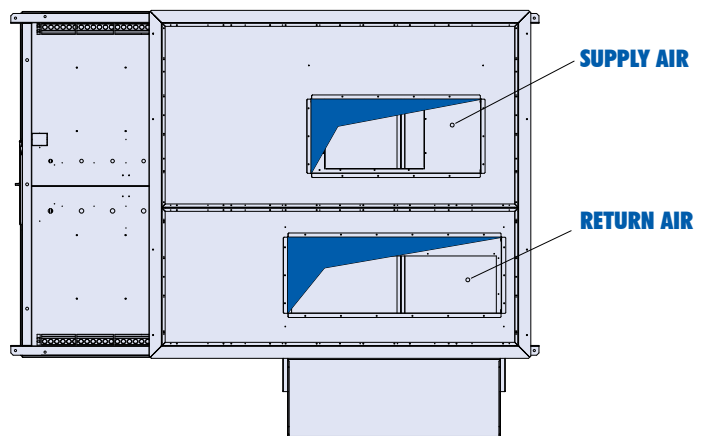
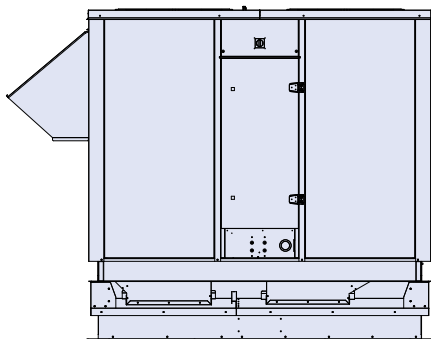
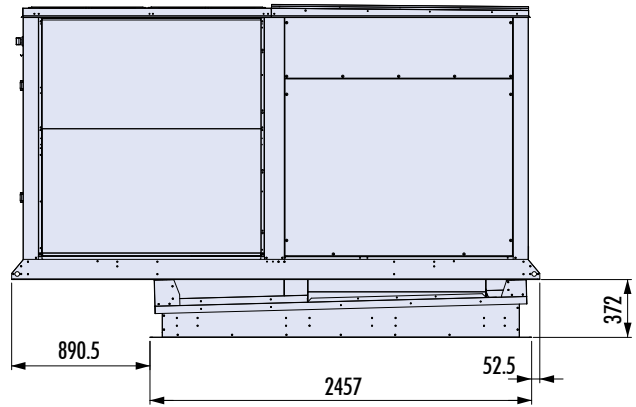
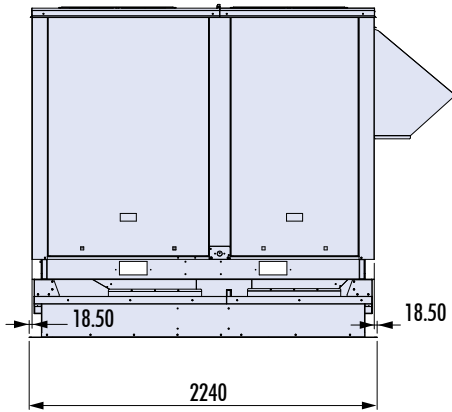

Sizes 60 to 80

Sizes 100 and 110

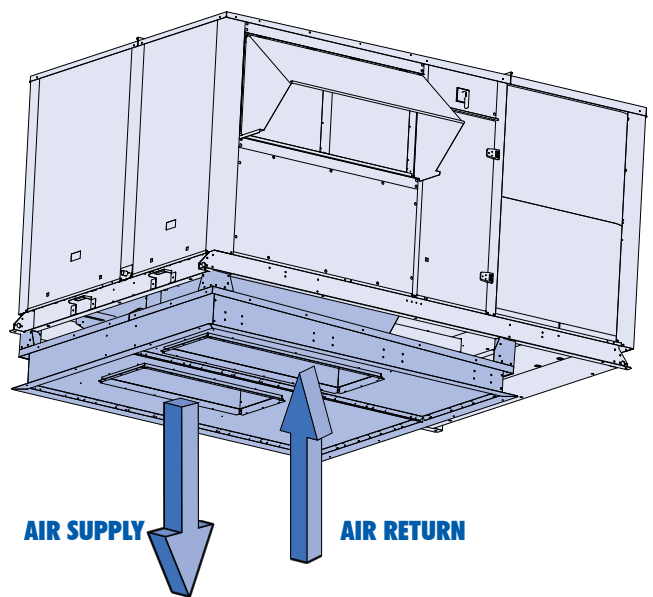
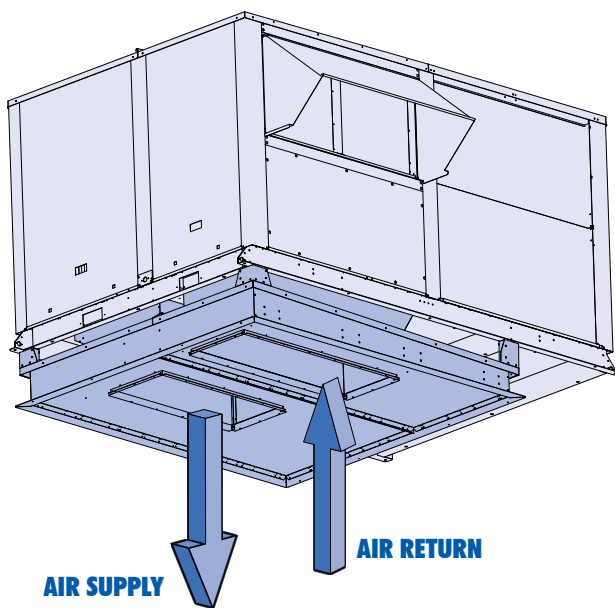

Accessories Weight (kg)

Modèles RTL/RTH	30	40	50	60	70	80	100	110
Electric heater CH1	51	51	51	65	65	65	65	65
Electric heater CH2	51	51	51	65	65	65	65	65
Hot water coil	15	15	15	20	20	20	20	20
25 mm thick G4 filter	20	20	20	30	30	30	30	30
G4 + F6 filters	25	25	25	40	40	40	40	40
Economizer (1)	41	41	41	72	72	72	72	72
Double skin	54	54	54	80	80	80	80	80
Standard roof curb	125	125	125	145	145	145	145	145
ERP roof curb	175	175	175	260	260	260	260	260

(1) Weather hood is integrated in this option.

Unit Clearance Requirements (mm)

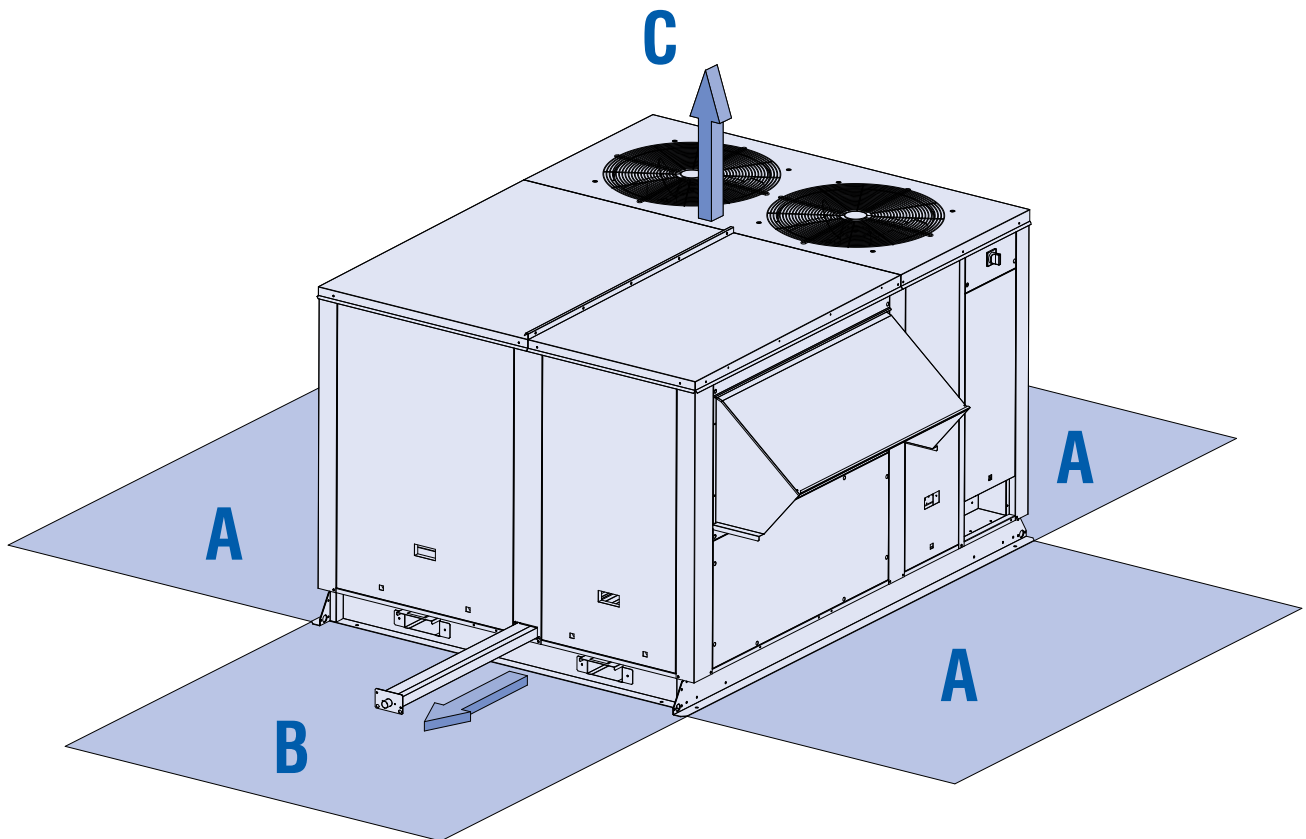

Models RTL/RTH	30	40	50	60	70	80	100	110
A	1200	1200	1200	1500	1500	1500	1500	1500
B*	1400	1400	1400	1600	1600	1600	1600	1600
C	3000	3000	3000	3000	3000	3000	3000	3000

* Mandatory for drain pan removal.

Specification Guide

GENERAL

- The rooftop shall be manufactured in factory certificated ISO 9001:2000 and shall be compliant to PED-97-23 and EN-60204-1.
- The rooftop shall be RoofT@ir or equivalent.
- The rooftop shall be designed for outdoor use and roof curb application.
- Pre-assembled in one single package fully tested at the factory.

CASING

- All panels exposed to the weather shall be manufactured of galvanized steel, painted with RAL 9001 to withstand salt spray test ISO-9227 and NFT-30077.
- The base rail shall provide two slots for fork transport and 4 points for lifting.
- Unit base shall be compatible with a roof curb manufactured by the same provider.
- All side panels of the treated air shall be at least insulated with 25 mm non-flammable and non-hygroscopic 62 kg/m³ fibreglass insulation. The insulation shall not be glued, but only supported by galvanized steel U-shape stiffeners. Double wall panel shall be optional to improve interior's cleanness and air quality.
- All panels attached with quarter-turn latches shall be removable for easing components' services.

REFRIGERANT CIRCUIT

- The refrigerant circuit shall be charged with R410A at the factory. The refrigerant piping, the indoor and outdoor coil headers, compressors and all refrigerant devices shall be located in the same compartment, with a reduced number of soldered joints. The high and low refrigerant pressure taps shall be accessible from outside of the casing to not disturb unit operation.
- Rooftop shall have at least 2 compressors for multistage operation.
- For heat pump, each refrigerant circuit shall be reversible and equipped with four-way valve, bi-flow thermostatic expansion valve, bi-flow filter-drier, sight glass and high/low pressure switches.
- The indoor and outdoor coils shall be made of copper tubes mechanically expanded into aluminium fins. The coils shall be tested at the factory at 42 bars.
- The condensate drain pan under the indoor coil shall be constructed with a slope, and shall be removable for cleaning.

MAIN BLOWER

- The main blower shall consist of centrifugal forward curved fan with double inlets, dynamically and statically balanced in compliance with VDI 2060 standards.
- The drive shall be of the belted pulley type.
- A flexible connector inside the unit and mounted on a removable frame, shall provide the link between the fan/motor assembly and the end of the panel.
- The minimum motor insulation class shall be IP55 in compliance with EN 60529 (IK08 in compliance with EN 50102). They shall an efficiency class of IE2 according to IEC 60034-30 standard.

- The mechanical adjustment of the Fan/Motor assembly (belt tension) shall be by way of a single piece sliding platform adjustable by a single screw, without having to slacken the motor mounting. Thus, motor alignment shall remain fixed.
- As standard equipment, Fan/Motor assembly shall be mounted on rubber vibration-absorbing pads. This assembly shall not rest directly on the floor panel but shall rest on an intermediate base frame comprising at least 2 main cross members in order to spread the load generated by the Fan / Motor assembly in a even manner.
- 4 different configurations possible for supply and return air flow.

Option : Backward curved blades shall be used for high external static pressure application.

Option : Differential pressure switch shall be provided to measure air pressure difference at the inlet and the outlet of the blower.

ELECTRICAL PANEL AND CONTROLS

- Automation and controls shall be assembled and wired at the factory in a waterproof compartment isolated from the air steam, in compliance with EN-60204-1. All internal cables and wires shall be identified. A lockable main disconnect switch shall be operable without touching the casing. Rooftop shall have only one power switch whatever the options.
- The unit shall be controlled by a regulation module programmed at the factory to control heating-cooling, ambient temperature setting and control, compressor cycling and rotation, defrost cycling, overload protection of motors, high-low pressure as well as winter-summer ambient temperature compensation, and setting point. The controller shall store at least 150 failures.

Option : The installation shall be supplied with a communication system permitting to monitor until 31 units, to centralize and coordinate all units by one user-interface.

Option : The controller shall be equipped with a RS-485 Interface to allow for remote supervision, servicing and communication via ModBUS, from the Building Management System.

ROOF CURB

The roof curb shall be supplied by the manufacturer :

- Roof curb shall be adjustable for a roof slope up to 5° with a return air plenum. To avoid noise transmission under the compressors, it shall be insulated.
- Roof curb shall be ERP type to allow air circulation between unit and building. It shall be compliant with article CH40 of the French building regulation.

Specification Guide (continued)

SPECIAL FEATURES

Economizer

The rooftop shall be factory assembled with an ECONOMIZER. The economizer shall have two counteracting dampers linked together to an actuator, modulating proportionally the volume of outdoor and return air from 0 to 100%.

The blades shall be constructed of galvanized steel with transmission gear-wheel. Retractable weather hood with bird screen shall protect the outdoor air damper.

Economizer shall have one of the following controls:

- Sensible control using temperature difference (RAT: Return Air Temperature & OAT : Outdoor Air Temperature).
- Enthalpy control using temperature and humidity sensor to define enthalpy difference (RAH & OAH).
- Quality control using air quality sensor placed on the return to ensure the necessary ventilation with more outdoor air to dilute the contaminants and maintain supply air quality.

Exhaust air blower

An exhaust air blower shall be provided with unit when economizer is fitted. The exhausted air shall not be short-circuited with the outdoor air intake. The volume of rejected air shall be at least 25% of the nominal air flow of the unit.

Hot water heating

The hot water coil shall be supplied with a modulating 3-way valve. The coil shall be mounted on a sliding rail down stream of the DX indoor coil. The hot water coil shall have the same face area as the indoor coil. A freeze limit thermostat shall be factory fitted and open the valve, close the outdoor air damper.

Electric heat

The rooftop shall be factory supplied with an electric heater placed at the blower discharge in a non-flammable compartment to protect the motor against radiated heat. The electric elements shall be of stainless steel and provide 2-stage heats. Manual and automatic reset safety thermostats shall be factory fitted and wired to the control devices.

Notes

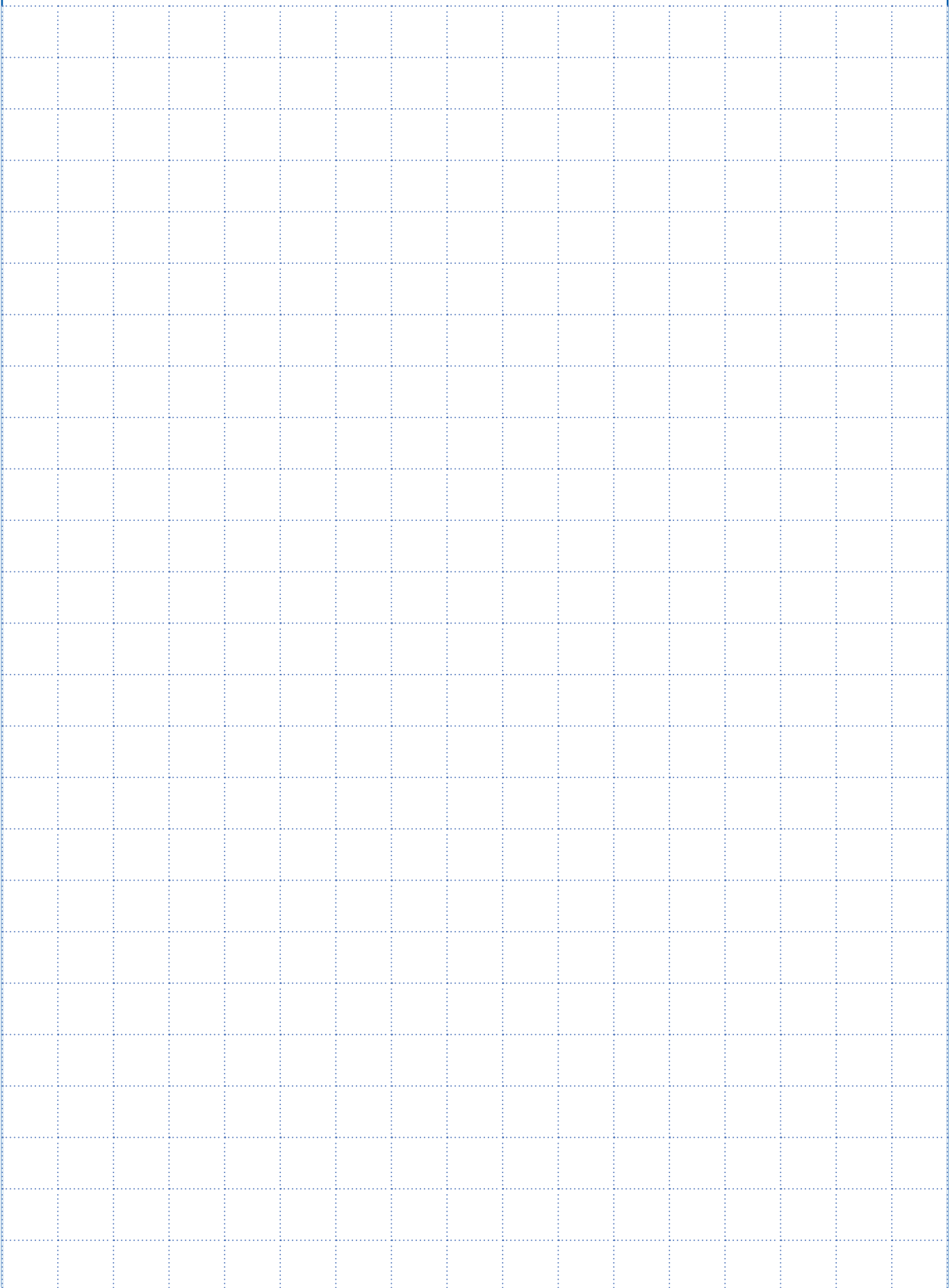
A large grid of dotted lines for writing notes, consisting of 20 columns and 30 rows.

Systemair AC SAS · route de Verneuil, 27570 Tillières-sur- Avre · Tél. 02 32 60 61 00 · Fax 02 32 32 55 13

