

PKI-C Cartridge Fire Dampers

Fire resistance class EI60S, EI90S and EI120S



1396-CPD-0050



PKI-C

Cartridge Fire Dampers

Cartridge dampers are designed in accordance with harmonized EN 15650 and certified to comply with the EI-S (EN 1366-2) performance attributes. PKI-C fire dampers are designed to be embedded into fire partition walls into transversal duct, or at the end of a duct in front of the valve. Installation of these devices is described in the Installation, Operation and Maintenance of the Cartridge Fire Dampers manual. As a standard, all the dampers are supplied in a basic version or with a microswitch, or accessories – cover plates, or with flexible duct coupling.

The fire damper automatically sets itself to a „CLOSE“ position if the thermal fuse link gets ruptured. After the closure, the damper blade is mechanically secured in the closed position and can only be opened manually, which requires access of the maintenance staff into the duct. To improve the duct accessibility for fire damper inspection purposes, we supply a flexible duct coupling as an accessory – labelled as TVKC in the Ordering Codes section. The thermal fuse link releases the coupling mechanism when the air temperature in the damper exceeds 72°C.

Damper Installation, Operation and Maintenance

The fire dampers should be installed, operated and maintained according to the Installation, Operation and Maintenance manual which is delivered with each PKI-C.

Workplace Conditions

The damper may be installed in the duct, in which the operating temperatures fall within the range of -10 to 65°C. The active fire-proof sealing must not be exposed to direct contact with water. The maximum air flow speed is 12m/s with purge air without mechanic or chemical contamination with uniform flow, without condensation, ice coating and ice. The device is not actuated until the ambient temperature reaches 65°C. In case of need of adjustment for higher temperatures in the workplace it is necessary to consult such demands with the producer and indicate them in the purchase order accordingly. In terms of their construction, the dampers are designed for use with a horizontal or a

vertical blade axis.

Transportation, Storage and Operating Conditions

It is necessary to transport the dampers in boxes, by such means of transport that provide a cover. When handling during transportation and storage, the dampers must be protected against damage and weather conditions. The damper blades must be in the “CLOSE” position. It is recommended to store these products in a closed, dry area where the temperature falls within the range of -10°C to +50°C.

The temperature during storage, transportation and operation must not exceed 65°C!

Material Used and Disposal

The product contains galvanized steel sheets, a calcium-silicate board, graphite fire-proof laminate, polyurethane foam, ethylene-propylene dry rubber, copper sheets, a special solder produced on a basis of Sn, Bi, Pb and powder paint. These are processed in compliance with the local regulations. The product does not contain any dangerous materials, with the exception of the solder’s miligram quantity that contains Pb.

Warranty

The manufacturer provides a 24-month warranty period starting on the date of expedition, provided that the transportation, manipulation and operating conditions are met.

Appendix

Any demands regarding deviations from the above mentioned technical specifications and conditions shall be discussed with the manufacturer. The manufacturer reserves the right to perform any modifications of the product without prior notice, provided that such changes have no effect on the quality and performance of the product.

Damper Codes and Types

Ordering Code - PKI-C

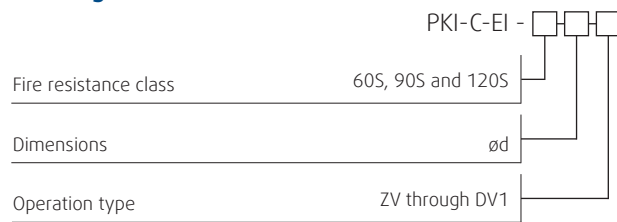

NOTE: E = Casing integrity, I = Thermal insulation, S = Smoke leakage

ZV; Basic model with a spring return release driven by a thermal fuse link set to 72 °C.

DV1; ZV + 230V end switch indicating the damper's closed and open position

Ordering Code - Cover Plates

PRC-ND

NOTE: ND = Nominal dimension in table on page 4

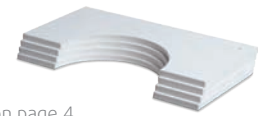

A complete set of four cover plates made of calcium-silicate boards (for usage during the installation please see the Installation, Operation and Maintenance manual).
FOR DRY INSTALLATION COVERPLATES ARE OBLIGATORY!

Ordering Code - Flexible duct coupling

TVKC-ND

NOTE: ND = Nominal dimension in table on page 4



A flexible coupling for easier accessibility during inspections is placed directly behind the built-in duct to a side where the damper blades open.

PKI-C-EI60S, -EI90S and -EI120S

We offer cartridge fire dampers with fire resistance class of 60, 90, 120 minutes for circular duct systems.



The cartridge fire dampers fulfil EN 15650, have been tested in accordance with the EN 1366-2 regulation and classified in accordance with the EN13501-3 regulation:

| | | |
|--|--|------------------------|
| PKI-C EI60S-ZV through DV1 For dimensions ø100 mm through ø200 mm Conformity certificate no.: 1396-CPD-0050 Classification protocol no.: FIRES-CR-186-11-AUPE Test report no.: FIRES-FR-200-11-AUNE FIRES-FR-217-11-AUNE | Installation: Solid wall – wet and dry Flexible wall – wet Ceiling – wet | EI 60 (ve ho i ↔ o) S |
| PKI-C EI90S-ZV through DV1 For dimensions ø100 mm through ø200 mm Conformity certificate no.: 1396-CPD-0050 Classification protocol no.: FIRES-CR-182-11-AUPE Test report no.: FIRES-FR-180-11-AUNE FIRES-FR-199-11-AUNE | Installation: Solid wall – wet and dry Flexible wall – wet and dry Ceiling – wet | EI 90 (ve ho i ↔ o) S |
| PKI-C EI120S-ZV through DV1 For dimensions ø100 mm through ø200 mm Conformity certificate no.: 1396-CPD-0050 Classification protocol no.: FIRES-CR-182-11-AUPE Test report no.: FIRES-FR-180-11-AUNE FIRES-FR-199-11-AUNE | Installation: Solid wall – wet and dry Flexible wall – wet and dry Ceiling – wet | EI 120 (ve ho i ↔ o) S |

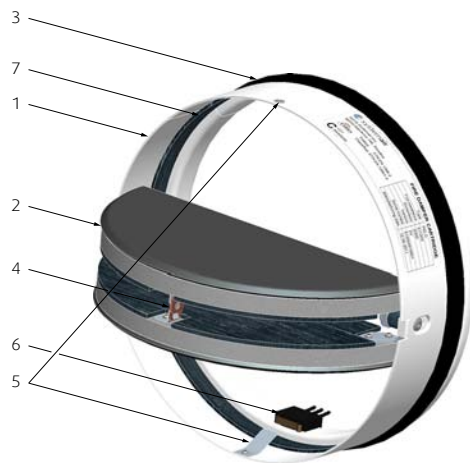

Damper Parts Description:

- 1. Casing
- 2. Damper blades
- 3. External peripheral sealing
- 4. Thermal fuse link
- 5. Detent spring
- 6. End switch 24 V DC / 230 V AC
- 7. Internal peripheral sealing, expanding material

Fig. 1: Design and dimensions of the cartridge fire damper

Main Dimensions and Weight

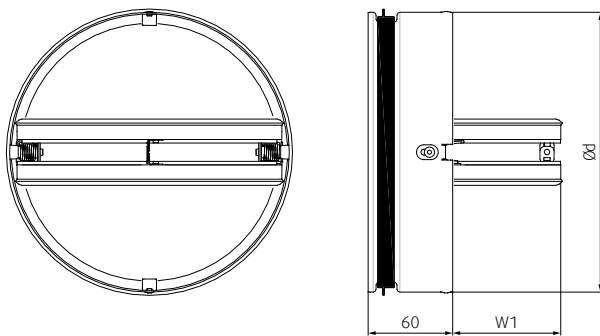

| ND (mm) | d (mm) | EI60/90/120S W1 (mm) | EI60S M (kg) | EI90/120S M (kg) |
|------------|-----------|-------------------------|-----------------|---------------------|
| 100 | ND-1,5 | 27 | 0,3 | 0,3 |
| 125 | | 39,5 | 0,4 | 0,4 |
| 140 | | 47 | 0,5 | 0,5 |
| 150 | | 52 | 0,4 | 0,6 |
| 160 | | 57 | 0,5 | 0,6 |
| 180 | | 67 | 0,6 | 0,7 |
| 200 | | 77 | 0,7 | 0,9 |

Connection of the End Switch

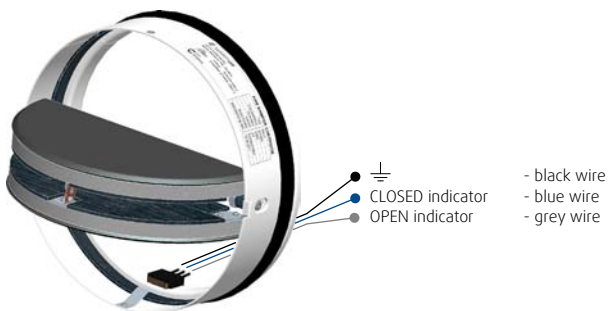

Adjustment of the Blades into the Operating Position

1. Press both detent springs

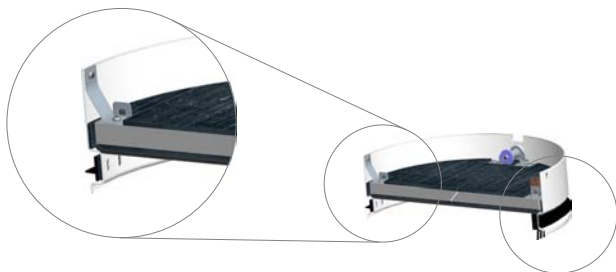

2. Open the blades into a parallel position



3. Click on the thermal fuse

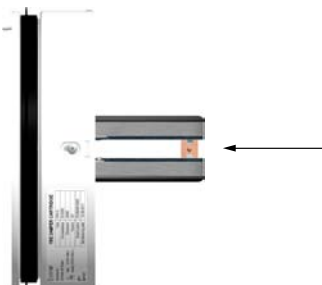

Pressure Loss and Noise

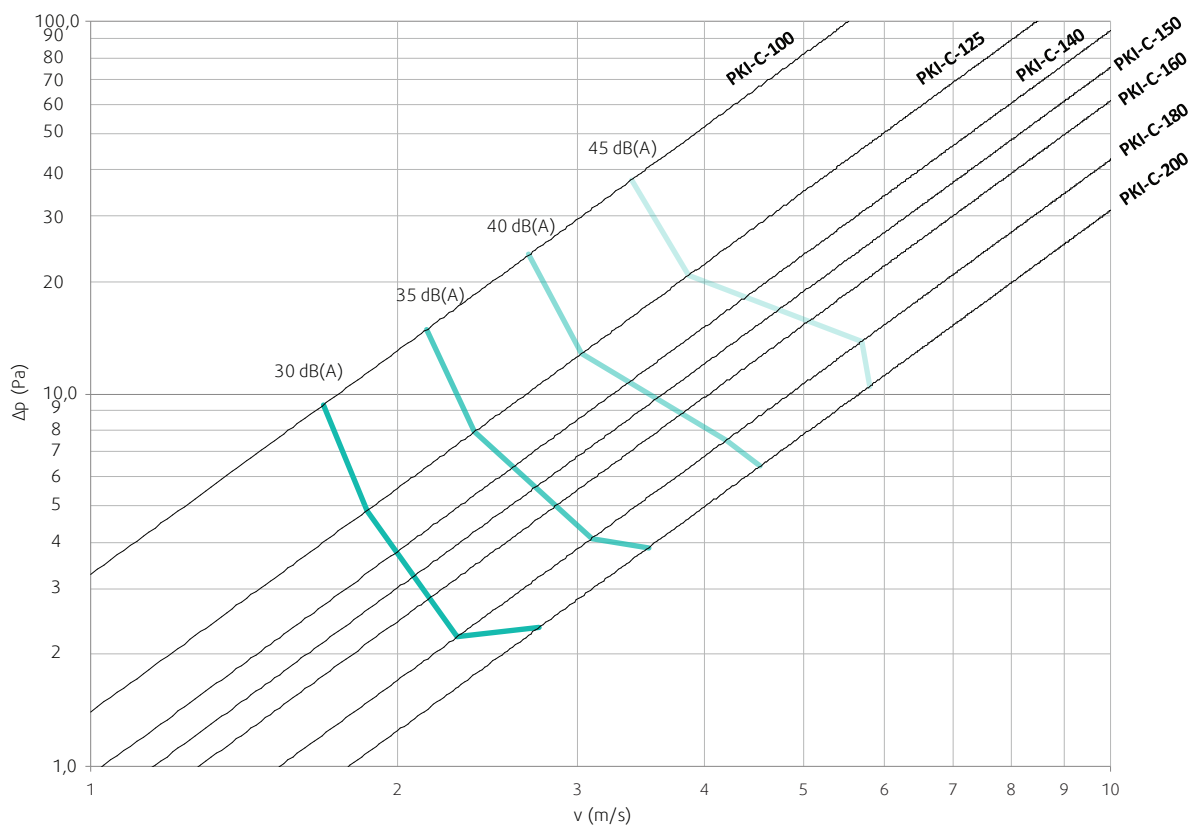

Installation

Wall Installation

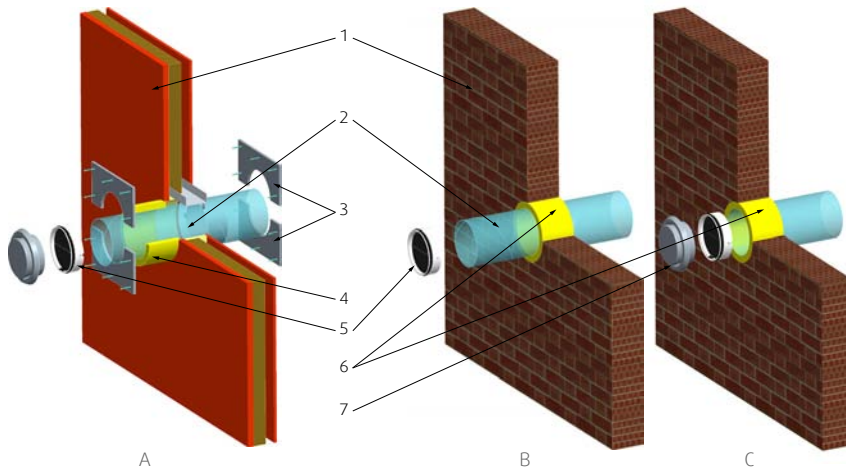

1. wall
2. duct
3. installation plates
4. mineral wool
5. PKI-C
6. gypsum / mortar / concrete
7. disk valve

A – dry installation using the cover plates into continuous ducts
 B – wet installation into continuous ducts
 C – installation into the end of a duct with a disk valve

Ceiling Installation

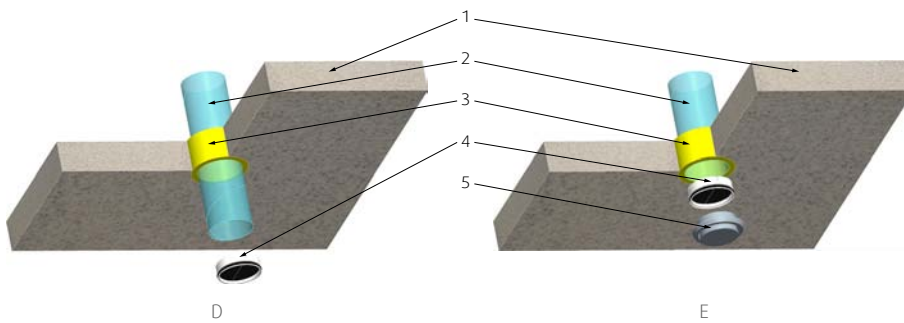

1. ceiling
2. duct
3. gypsum / mortar / concrete
4. PKI-C
5. disk valve

D – installation into continuous ducts
 E – installation with a disk valve orifice

Installation Into the End of a Duct with a Valve

It is possible to install the cartridge fire damper at the end of a duct in a wall / ceiling with a disc valve (it is needed to order the valve separately from the APD catalogue - suitable plastic air valve is "Balance-E" from Systemair AB, Sweden)

| Plasterboard wall | EI60S | EI90S | EI120S |
|-------------------------------|---------|---------|---------|
| H [mm] | 100 | 125 | 150 |
| RF [mm] | 12.5 | 12.5 | 12.5 |
| D1/ρ [mm/kg.m ⁻³] | 40/40 | 60/50 | 60/100 |
| MR PKI-C [mm] | 100÷200 | 100÷200 | 100÷200 |

Plasterboard wall according to STN EN 1366-3

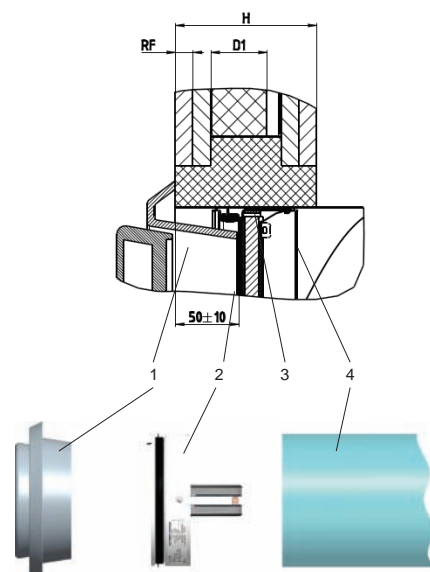

1 - disc valve, 2 - PKI-C, 3 - gypsum, 4 - duct

Technical Parameters

| | | |
|--------------------------|---|--|
| Durability test | - | 50 cycles without a change to the required attributes |
| Testing pressure | - | 300 Pa |
| Safe position | - | Closed |
| Possible installations | - | Vertical/horizontal, solid/flexible wall, wet/dry (see the certification and classification table) |
| Airflow direction | - | Optional |
| Side protected from fire | - | Optional |
| Closure | - | By springs after the thermal fuse melts - 72 °C as standard, other options based after agreement with the manufacturer |
| Ambient temperature | - | In case of a 72 °C thermal fuse, the temperature should be a maximum of 65 °C |
| Repeated opening | - | It is possible to open the device manually when it is cold |
| Closed/open indicator | - | 24 V DC / 230 V AC microswitch in version DV1 |
| Suitability for ambience | - | Inside only |
| Inspection possibility | - | After installing the flexible coupling into an adjacent duct (see the PS option in the Ordering Codes section) |
| Maintenance | - | Not needed |

IMOS-Systemair

