



IGK Square external Louver

Function

Intake grid manufactured from galvanised sheet steel with wall flange and insect mesh. Connection sleeve with a rubber seal.

Selection Table

Table below shows the general product performance for more details please see selection software or contact your local

Dimensions

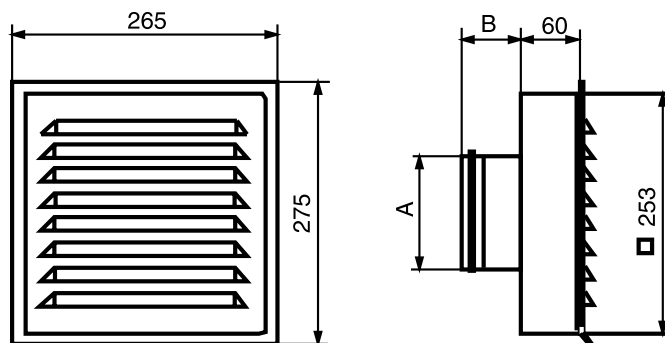

	ØA	B
IGK 100	100	37
IGK 125	125	37
IGK 160	160	37
IGK 200	200	41

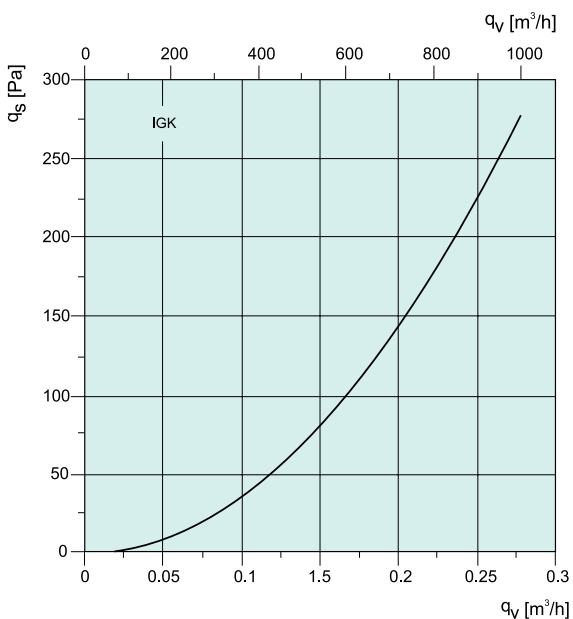

IGK					
Size	Art No	Min AirFlow (m³/hr)	Min Pressure (pa)	Max AirFlow (m³/hr)	Max Pressure (pa)
100	1630	70	2	760	160
125	1631	70	2	760	160
160	1632	70	2	760	160
200	1633	70	2	760	160