

KD fans

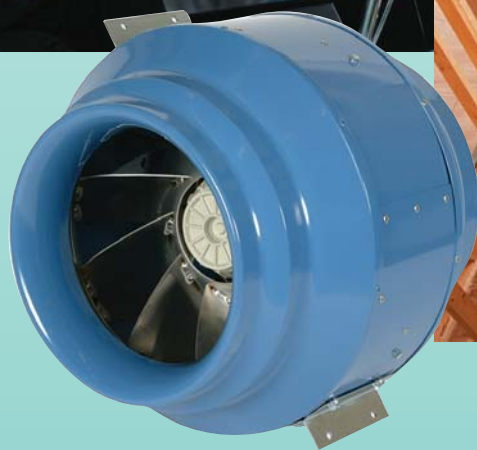

We made the first circular duct fan



KD-series – compact, light, economical

Since we introduced the first circular duct fan in 1974 we have worked on developing the concept. A result of this is our successful KD-series.

These fans have mixed flow impellers with a design where the air passes through at approx. 45° angle to the shaft.

The mixed flow fan provides more air flow than a corresponding radial fan and higher pressure capacity than a corresponding axial fan. The design also has several advantages:

- Compact fan with small outer measurements
- Quieter operation
- Easy installation and service

Compact design

The KD fans have a high capacity in relation to their compact design. The bearings are maintenance free. The casing and impeller are manufactured from galvanised sheet steel. The fans are delivered with a blue powder-coated finish.

Quieter operation

The fan is quieter than other solutions with the same performance and creates a sound which is evenly distributed over the octave bands.

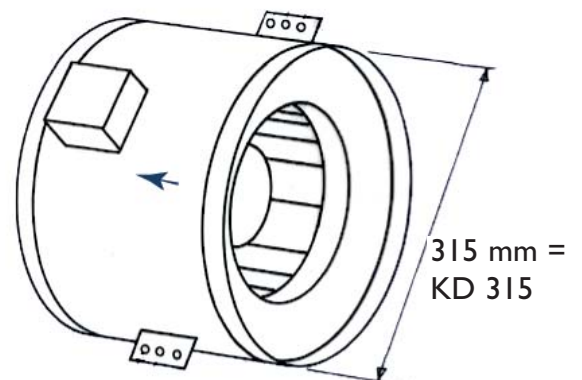



Easy installation and service

The KD fans are available with connection diameter 200-500 mm. Brackets are supplied with the fans to make installation easier. The accessory FK mounting clamp also

facilitates easy installation and removal and prevents the transfer of vibration to the duct. The fan impellers are easy to clean.

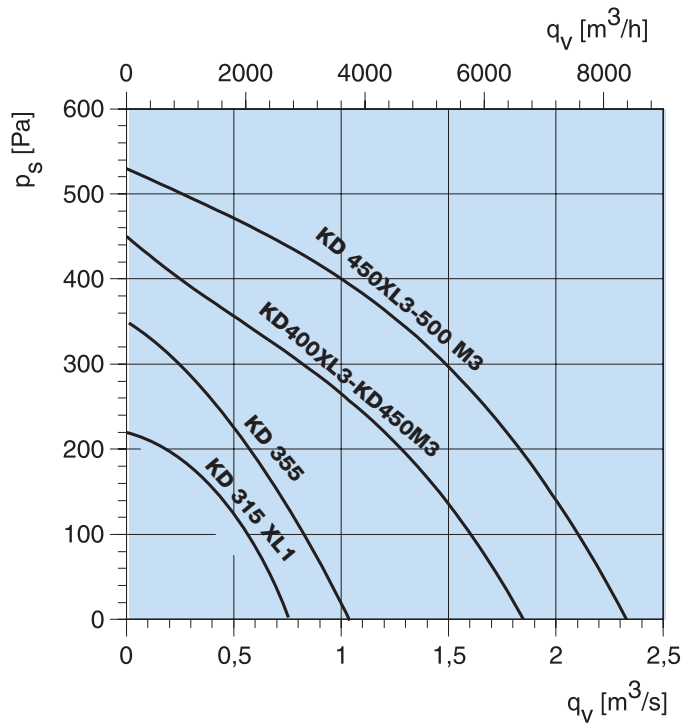
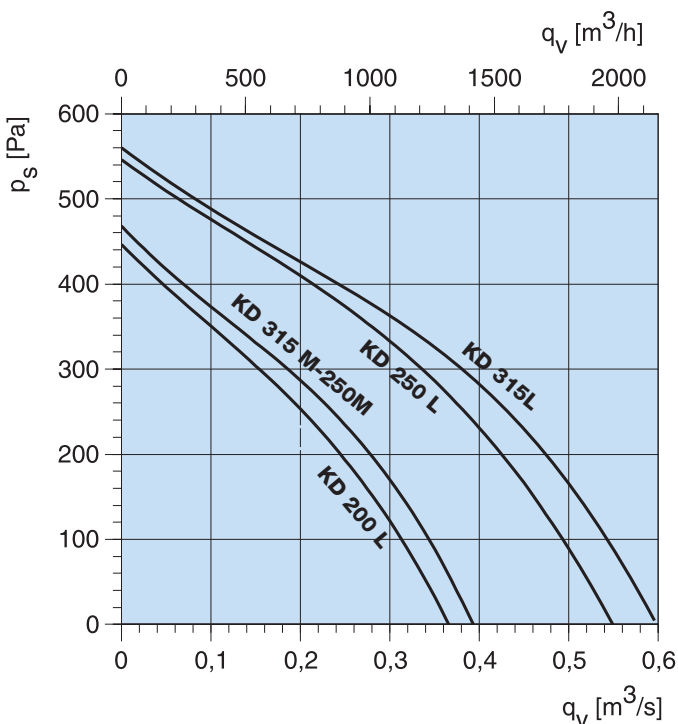



Systemair Ltd • Medway City Estate, Rochester Kent ME2 4ER, Great Britain • Tel: +44 1634 735 000 • Fax: +44 1634 735 001
Systemair • Unit 02 Furry Park, Santry, Dublin 9, Ireland • Tel +353 1 862 45 44 • Fax +353 1 862 80 30
Head Office Systemair AB • SE-739 30 Skinnkatteberg, Sweden • Tel +46 222 44000 • +46 222 44099