



## DVP

- Temperature of transported air from -15°C to +60°C
- Single inlet impellers from PP with effective blade geometry
- Weather-resistant, sturdy casing made from PP
- Motor and terminal box in IP55
- Capsulated motor, outside the airstream

The DVP fans have been developed especially for the exhaust of aggressive media. This is the right fan when corrosive gases, contaminated air or other aggressive components are part of the exhaust air. Typical applications are medical facilities, the food-, electrical-or chemical industry. The casing from PP offers a variety of applications with its connectors from  $\varnothing 200 - 400$  mm. Motor protection by protection switch.

## ELECTRICAL ACCESSORIES



STDT p. 342



S-DT2 SKT p. 340

## QUICK SELECTION

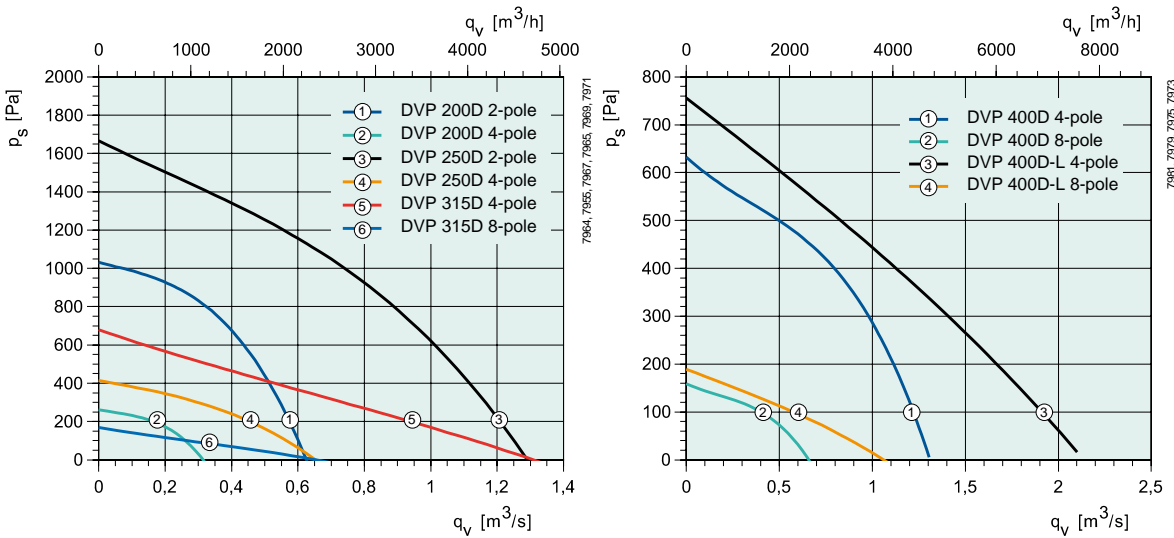

## TECHNICAL DATA

DVP		200D2-4	200D2-4	250D2-4	250D2-4	315D4-8	315D4-8
		2-pole	4-pole	2-pole	4-pole	4-pole	8-pole
Art no.		32295		32296		32297	
Voltage/Frequency	V/50 Hz	400 3~	400 3~	400 3~	400 3~	400 3~	400 3~
Power "P2"	W	1500	370	3600	900	2200	500
Current	A	3.4	0.84	7.7	2.0	4.8	1.98
Max air flow	m³/s	0.628	0.316	1.27	0.649	1.28	0.647
R.p.m.	min-1	2885	1468	2874	1468	1494	732
Max temp. of transported air	°C	60	60	60	60	60	60
Sound pressure level at 4 m/10 m	dB(A)	62/54	43/35	69/61	51/43	55/47	40/32
Weight	kg	25	25	35	35	45	45
Insulation class, motor		F	F	F	F	F	F
Enclosure class, motor		IP 55	IP 55	IP 55	IP 55	IP 55	IP 55
Wiring diagram p. 391-400		14a	14a	14a	14a	14a	14a

DIMENSIONS

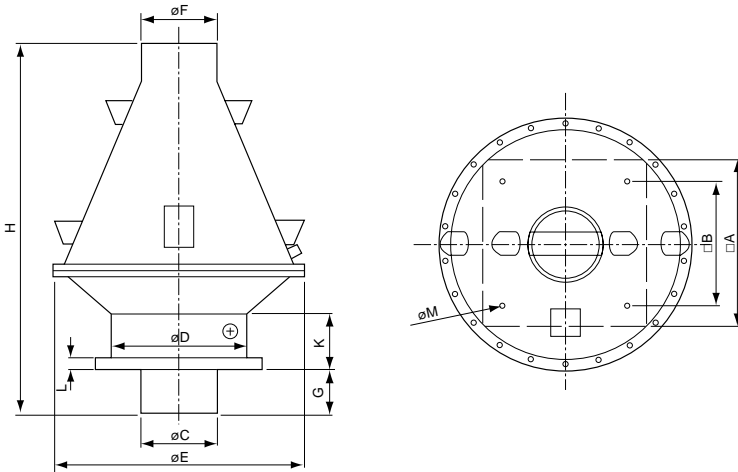

VENTILATION ACCESSORIES



SSD p. 374



FDS p. 374

	□A	□B	øC	øD	øE	øF	G	H	K	L	øM
DVP 200	435	330	200	355	662	200	119	1065	146	30	4x10
DVP 250	595	450	250	400	768	250	119	981	181	30	4x12
DVP 315	665	535	315	560	810	315	218	1161	200	30	4x12
DVP 400	939	750	400	601	976	400	218	1134	235	30	4x14

DVP 200 = SSD/FDS 310/311  
 DVP 250 = SSD/FDS 355/400  
 DVP 315 = SSD/FDS 450/500  
 DVP 400 = SSD/FDS 560/630

DVP		400D4-8	400D4-8	400D4-8-L	400D4-8-L		
		4-pole	8-pole	4-pole	8-pole		
Art no.		32299		32298			
Voltage/Frequency	V/50 Hz	400 3~	400 3~	400 3~	400 3~		
Power	W	2000	500	3600	900		
Current	A	4.8	1.98	7.9	2.0		
Max air flow	m³/s	1.31	0.661	2.11	1.05		
R.p.m.	min-1	1445	732	1447	733		
Max temp. of transported air	°C	60	60	60	60		
Sound pressure level at 4 m/10 m	dB(A)	60/52	44/36	61/53	47/39		
Weight	kg	55	55	55	55		
Insulation class, motor		F	F	F	F		
Enclosure class, motor		IP 55	IP 55	IP 55	IP 55		
Wiring diagram p. 391-400		14a	14a	14a	14a		

# Aggressive media roof fans

## PERFORMANCE

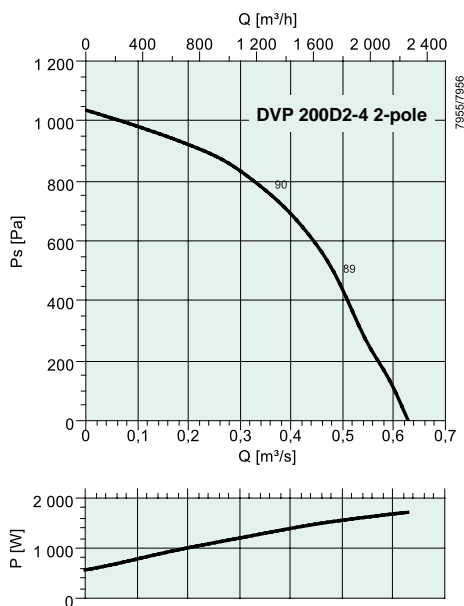

dB(A)	Tot	Frequency bands [Hz]							
		63	125	250	500	1k	2k	4k	8k
L <sub>WA</sub> Inlet	90	71	74	83	86	83	78	69	61
L <sub>WA</sub> Surrounding	85	61	65	78	81	77	76	69	62

Measurement point: 0,36 m³/s; 755 Pa

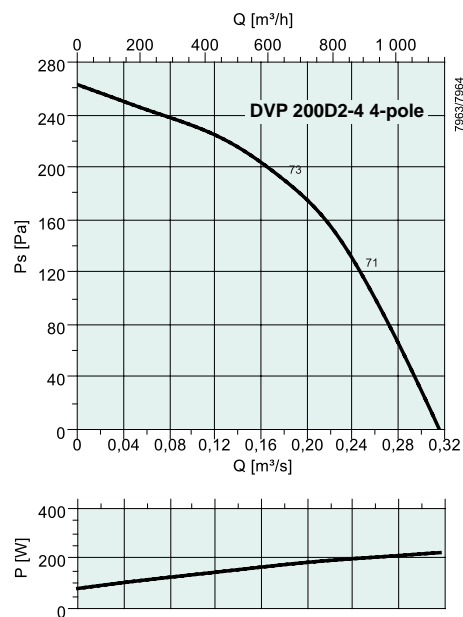

dB(A)	Tot	Frequency bands [Hz]							
		63	125	250	500	1k	2k	4k	8k
L <sub>WA</sub> Inlet	73	57	64	69	65	64	58	48	39
L <sub>WA</sub> Surrounding	66	46	54	61	61	57	55	48	39

Measurement point: 0,18 m³/s; 190 Pa

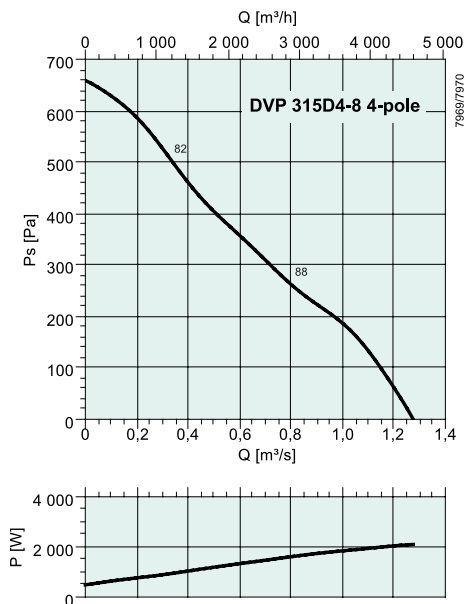

dB(A)	Tot	Frequency bands [Hz]							
		63	125	250	500	1k	2k	4k	8k
L <sub>WA</sub> Inlet	82	66	77	77	74	74	67	64	55
L <sub>WA</sub> Surrounding	81	70	75	73	74	73	68	64	57

Measurement point: 0,329 m³/s; 507 Pa

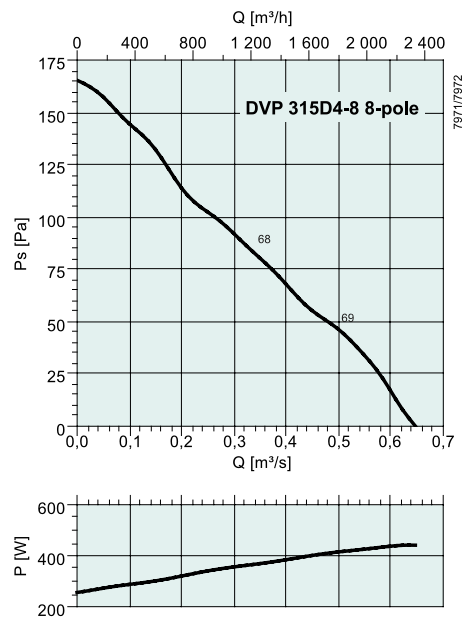

dB(A)	Tot	Frequency bands [Hz]							
		63	125	250	500	1k	2k	4k	8k
L <sub>WA</sub> Inlet	68	55	65	61	61	56	47	43	33
L <sub>WA</sub> Surrounding	63	45	52	53	61	54	49	45	37

Measurement point: 0,335 m³/s; 84 Pa

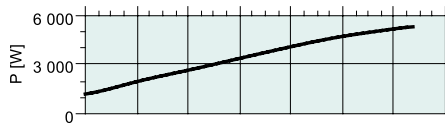
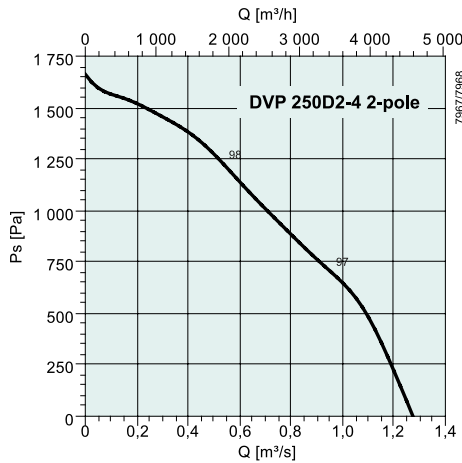

dB(A)	Tot	Frequency bands [Hz]							
		63	125	250	500	1k	2k	4k	8k
L <sub>WA</sub> Inlet	98	78	81	93	94	89	84	76	69
L <sub>WA</sub> Surrounding	95	83	80	86	91	87	85	78	71

Measurement point: 0,543 m<sup>3</sup>/s; 1218 Pa

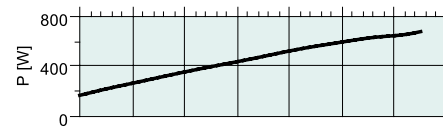
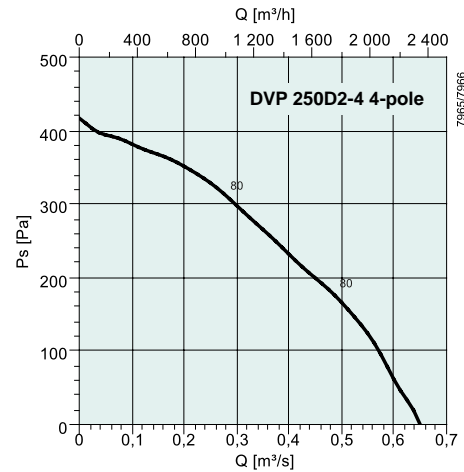

dB(A)	Tot	Frequency bands [Hz]							
		63	125	250	500	1k	2k	4k	8k
L <sub>WA</sub> Inlet	80	60	73	77	73	71	63	56	48
L <sub>WA</sub> Surrounding	78	69	68	72	73	70	63	56	49

Measurement point: 0,279 m<sup>3</sup>/s; 312 Pa

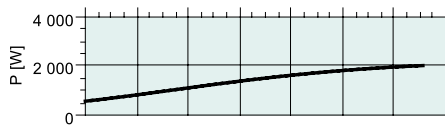
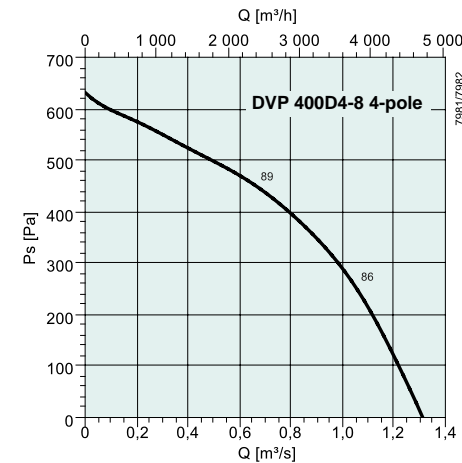

dB(A)	Tot	Frequency bands [Hz]							
		63	125	250	500	1k	2k	4k	8k
L <sub>WA</sub> Inlet	89	65	86	85	79	79	72	67	59
L <sub>WA</sub> Surrounding	87	72	81	83	78	76	72	68	60

Measurement point: 0,669 m<sup>3</sup>/s; 448 Pa

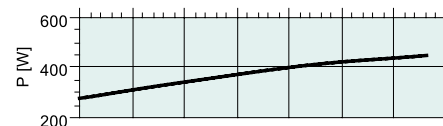
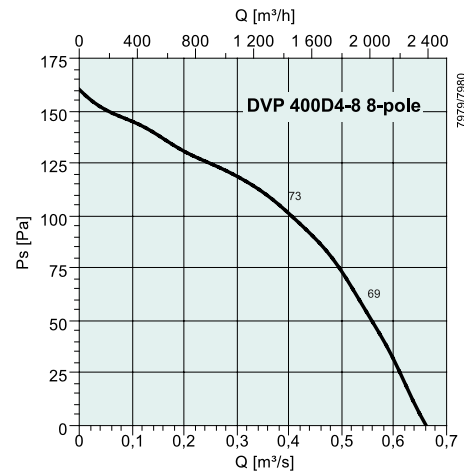

dB(A)	Tot	Frequency bands [Hz]							
		63	125	250	500	1k	2k	4k	8k
L <sub>WA</sub> Inlet	73	57	72	59	63	62	52	46	36
L <sub>WA</sub> Surrounding	76	62	75	59	62	56	51	46	36

Measurement point: 0,388 m<sup>3</sup>/s; 104 Pa

# Aggressive media roof fans

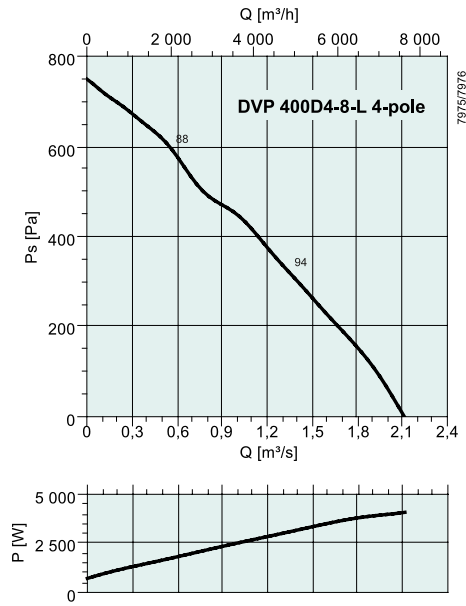

dB(A)	Tot	Frequency bands [Hz]							
		63	125	250	500	1k	2k	4k	8k
L <sub>WA</sub> Inlet	88	69	84	82	80	80	75	72	64
L <sub>WA</sub> Surrounding	86	72	77	80	78	79	75	71	63

Measurement point: 0,564 m³/s; 594 Pa

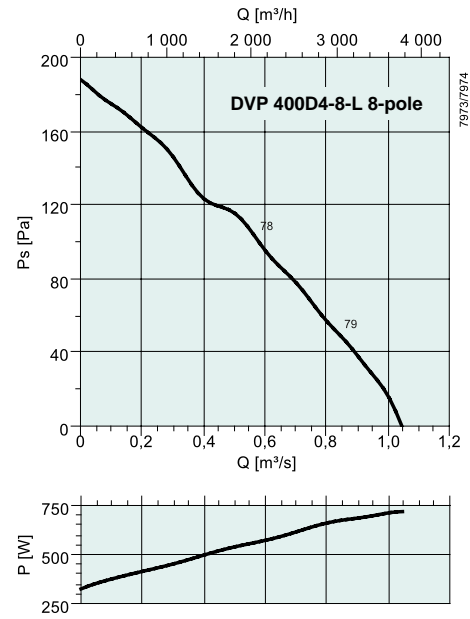

dB(A)	Tot	Frequency bands [Hz]							
		63	125	250	500	1k	2k	4k	8k
L <sub>WA</sub> Inlet	78	62	78	65	64	61	54	50	40
L <sub>WA</sub> Surrounding	76	63	75	63	65	59	54	49	40

Measurement point: 0,567 m³/s; 103 Pa