



DVN/DVNI

The casing and impeller with backward-curved blades is manufactured from seawater resistant aluminum. The base frame and the integrated protection guard consist of powder-coated galvanised steel.

The motor is suspended on effective vibration dampers. The motors are speed-controllable via transformer or frequency converter. To protect the motor from overheating the fan has integral thermal contacts or PTC with external leads for connection to a motor protection device.

The DVNI version has a 50 mm mineral wool insulation for lower sound level.



ELECTRICAL ACCESSORIES



QUICK SELECTIONS

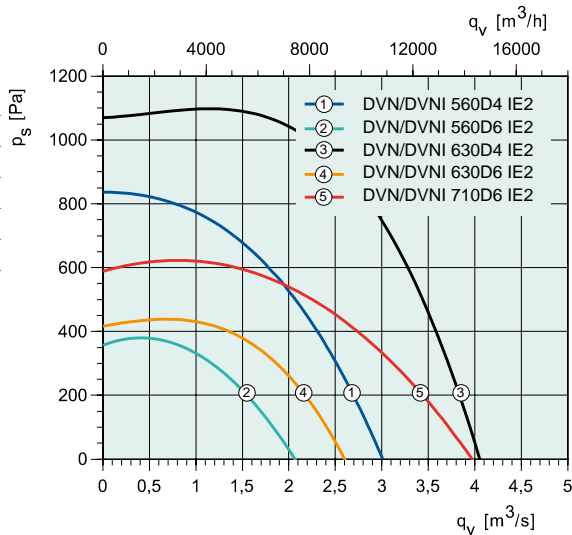
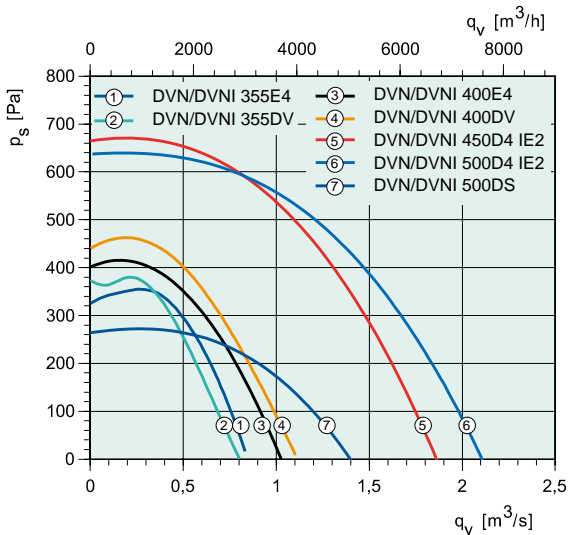

TECHNICAL DATA

DVN/DVNI	355E4	355DV	400E4	400DV	450D4 IE2	500D4 IE2	500DS
Art no. DVN Tech. data is relating to DVN	30301	30278	2630	2631	32184	32185	9852
Art no. DVNI	30446	30313	3909	3396	33462	33463	9857
Voltage/Frequency	V/50 Hz	230 1~	400 3~	230 1~	400 3~	400 Y 3~	400 Y 3~
Power at shaft	W	370	370	370	370	750	1500
Current	A	1.49	1.20	2.00	1.37	1.78	3.39
Max air flow	m³/s	0.846	0.839	1.00	1.1	1.85	2.12
R.p.m.	min-1	1408	1420	1420	1442	1390	1400
Max temp. of transported air	°C	120	120	120	120	120	120
Sound pressure level at 4 m/10 m*	dB(A)	49/41	50/42	52/44	52/44	53/45	56/48
Weight	kg	27/33	26/42	33/39	33/43	38/46	49/57
Insulation class, motor	F	F	F	F	F	F	F
Enclosure class, motor	IP 54	IP 54	IP 54	IP 54	IP 55	IP 55	IP 54
Capacitor	µF	12	-	12	-	-	-
Motor protection	S-ET 10	STDT 16	S-ET 10	STDT 16	U-EK230E		STDT 16
Speed control, five-step	RTRE 3	RTRD 2	RTRE 3	RTRD 2	FRQ5(S)-4A	FRQ5(S)-4A	RTRD 2
Speed control, five step high/low	Transformer	REU 3**	RTRDU 2	REU 3**	-	-	RTRDU 2
Speed control, two step	-	S-DT2SKT	-	S-DT2SKT	-	-	S-DT2SKT
Speed control, stepless	-	FXDM	-	FXDM	FRQ(S)-4A	FRQ(S)-4A	FXDM
Wiring diagram p. 391-400	21	17	21	17	13 b Y	13 b Y	20

* DVNI -9 dB, ** + S-ET 10

DIMENSIONS

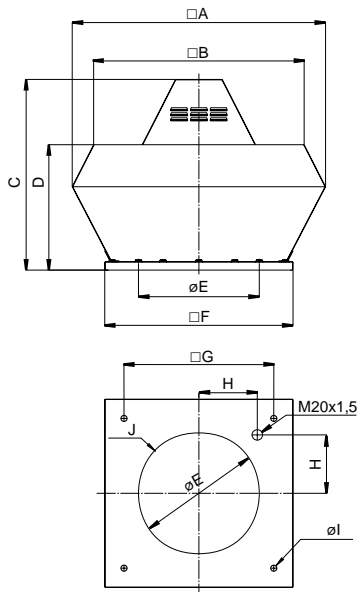

DVN	A	B	C	D	øE	F	G	H	øI	J
355-400	720	618	600	390	438	595	450	200	12(4x)	6xM8
450-500	900	730	675	465	438	665	535	237	12(4x)	6xM8
560-630	1150	955	900	560	605	939	750	293	14(4x)	8xM8
710	1350	1178	936	660	674	1035	840	320	14(4x)	8xM8

DVNI	A	B	C	D	øE	F	G	H	øI	J
355-400	874	648	600	439	438	595	450	200	12(4x)	6xM8
450-500	970	730	675	479	438	665	535	237	12(4x)	6xM8
560-630	1315	1035	900	600	605	939	750	293	14(4x)	8xM8
710	1483	1165	936	729	674	1035	840	320	14(4x)	8xM8

VENTILATION ACCESSORIES



SSD p. 374



FDS p. 374



ASK p. 380



VKS p. 380



VKM p. 380



ASS p. 381



ASF p. 375

Roof fans

DVN/DVNI	560D4 IE2	560D6 IE2	630D4 IE2	630D6 IE2	710D6 IE2
Art no. DVN, Techn. data is relating to DVN	32187	32188	33554	32189	33555
Art no. DVNI	33465	33466	33468	33467	33469
Voltage/Frequency	V/50 Hz 400 Y 3~	400 Y 3~	400 D 3~	400 Y 3~	400 Y 3~
Power at shaft	W 2200	750	4000	1500	2200
Current	A 4.64	1.98	8.12	3.61	5.1
Max air flow	m ³ /s 3.00	2.08	4.07	2.60	4.01
R.p.m.	min ⁻¹ 1420	905	1450	940	945
Max temp. of transported air	°C 120	120	120	120	120
Sound pressure level at 4/10 m	dB(A) 64/56	49/41	66/58	52/45	58/50
Weight	kg 58/70	57/69	65/79	65/79	210/102
Insulation class, motor	F	F	F	F	F
Enclosure class, motor	IP 55	IP 55	IP 55	IP 55	IP 55
Motor protection	U-EK230E	U-EK230E	U-EK230E	U-EK230E	U-EK230E
Speed control, five-step	FRQ5(S)-10A	FRQ5(S)-4A	FRQ5(S)-10A	FRQ5(S)-4A	FRQ5(S)-10A
Speed control, stepless	FRQ(S)-10A	FRQ(S)-4A	FRQ(S)-10A	FRQ(S)-4A	FRQ(S)-10A
Wiring diagram p. 391-400	13 b Y	13 b Y	13b D	13 b Y	13 b Y

Roof fans

PERFORMANCE

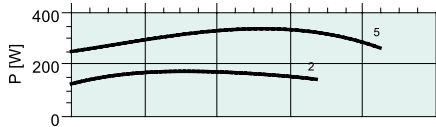
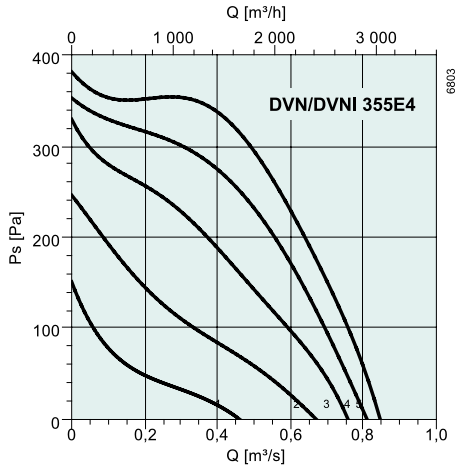

dB(A)	Tot	Frequency bands [Hz]							
		63	125	250	500	1k	2k	4k	8k
L_{wA} Inlet	70	41	59	63	65	64	61	56	49
L_{wA} Surrounding	72	43	61	65	67	66	63	58	51
DVNI									
L_{wA} Surrounding	63	34	52	56	58	57	54	49	42
With SSD 355/400									
L_{wA} Inlet	60	31	49	53	55	54	51	46	39

Measurement point: 0,45 m^3/s ; 315 Pa

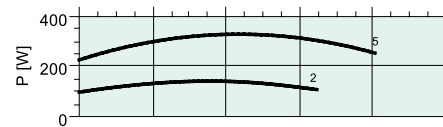
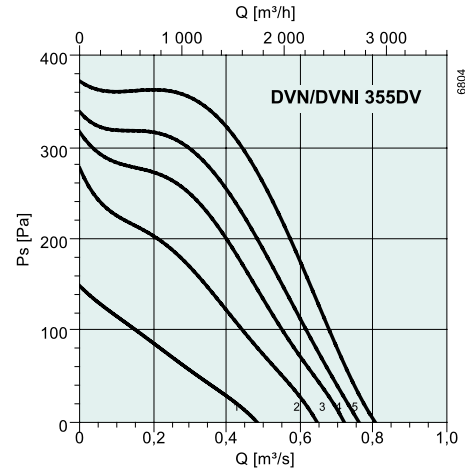

dB(A)	Tot	Frequency bands [Hz]							
		63	125	250	500	1k	2k	4k	8k
L_{wA} Inlet	70	41	59	63	65	64	61	56	49
L_{wA} Surrounding	72	43	61	65	67	66	63	58	51
DVNI									
L_{wA} Surrounding	63	34	52	56	58	57	54	49	42
With SSD 355/400									
L_{wA} Inlet	60	31	49	53	55	54	51	46	39

Measurement point: 0,45 m^3/s ; 315 Pa

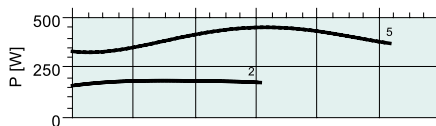
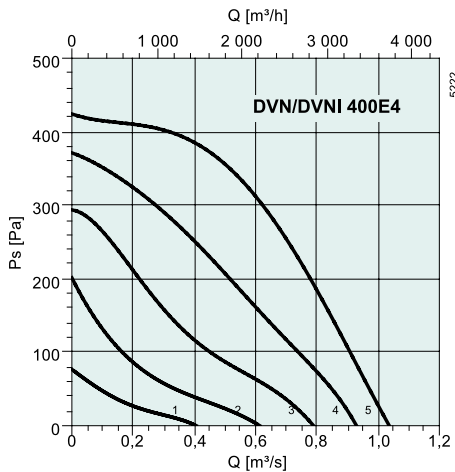

dB(A)	Tot	Frequency bands [Hz]							
		63	125	250	500	1k	2k	4k	8k
L_{wA} Inlet	73	60	62	66	68	67	64	59	52
L_{wA} Surrounding	75	62	64	68	70	69	66	61	54
DVNI									
L_{wA} Surrounding	66	59	59	61	60	56	47	45	39
With SSD 355/400									
L_{wA} Inlet	63	57	57	58	54	48	42	43	37

Measurement point: 0,69 m^3/s ; 249 Pa

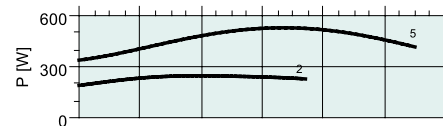
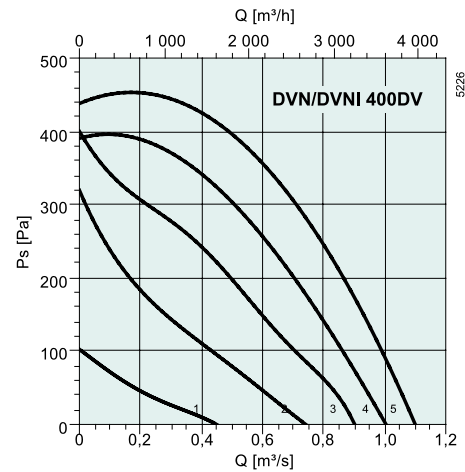

dB(A)	Tot	Frequency bands [Hz]							
		63	125	250	500	1k	2k	4k	8k
L_{wA} Inlet	73	60	62	66	68	67	64	59	52
L_{wA} Surrounding	75	62	64	68	70	69	66	61	54
DVNI									
L_{wA} Surrounding	66	59	59	61	60	56	47	45	39
With SSD 355/400									
L_{wA} Inlet	63	57	57	58	54	48	42	43	37

Measurement point: 0,74 m^3/s ; 285 Pa

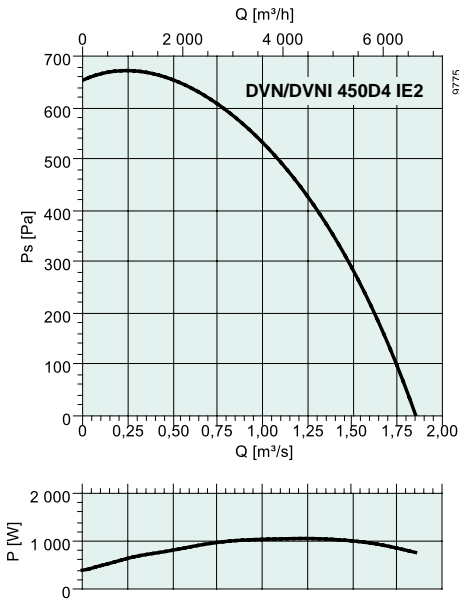

dB(A)	Tot	Frequency bands [Hz]							
		63	125	250	500	1k	2k	4k	8k
L_{WA} Inlet	74	61	63	67	69	68	65	60	53
L_{WA} Surrounding	76	63	65	69	71	70	67	62	55
DVNI									
L_{WA} Surrounding	67	60	60	62	60	54	47	45	39
With SSD 450/ 499/500									
L_{WA} Inlet	64	56	56	57	53	47	41	42	36

Measurement point: 1,11 m³/s; 489 Pa

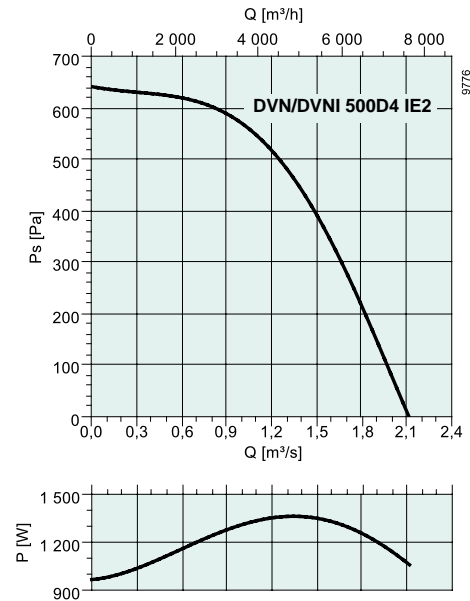

dB(A)	Tot	Frequency bands [Hz]							
		63	125	250	500	1k	2k	4k	8k
L_{WA} Inlet	78	65	67	71	73	72	69	64	57
L_{WA} Surrounding	80	67	69	73	75	74	71	66	59
DVNI									
L_{WA} Surrounding	71	64	64	66	64	58	51	49	43
With SSD 450/ 499/500									
L_{WA} Inlet	68	62	62	62	60	52	44	42	40

Measurement point: 1,50 m³/s; 400 Pa

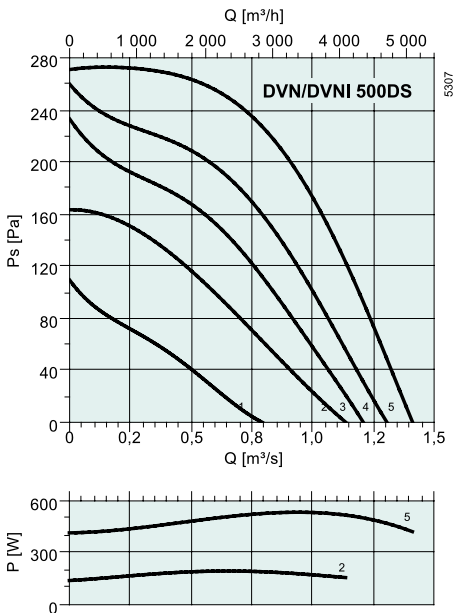

dB(A)	Tot	Frequency bands [Hz]							
		63	125	250	500	1k	2k	4k	8k
L_{WA} Inlet	68	55	57	62	63	63	59	54	46
L_{WA} Surrounding	70	57	59	64	65	65	61	56	48
DVNI									
L_{WA} Surrounding	61	54	54	57	54	49	41	39	32
With SSD 450/ 499/500									
L_{WA} Inlet	58	52	52	53	50	43	34	32	29

Measurement point: 0,69 m³/s; 250 Pa

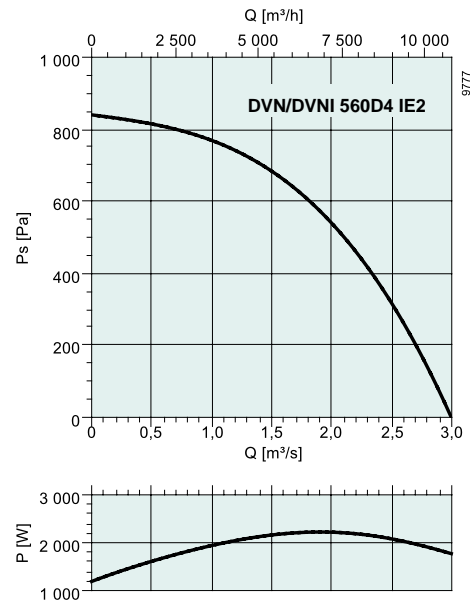

dB(A)	Tot	Frequency bands [Hz]							
		63	125	250	500	1k	2k	4k	8k
L_{WA} Inlet	79	66	68	72	74	73	70	65	58
L_{WA} Surrounding	86	73	75	79	81	80	77	72	65
DVNI									
L_{WA} Surrounding	77	70	70	72	70	64	57	55	49
With SSD 560/630									
L_{WA} Inlet	70	64	63	64	63	56	49	46	45

Measurement point: 1,5 m³/s; 701 Pa

Roof fans

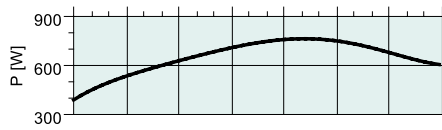
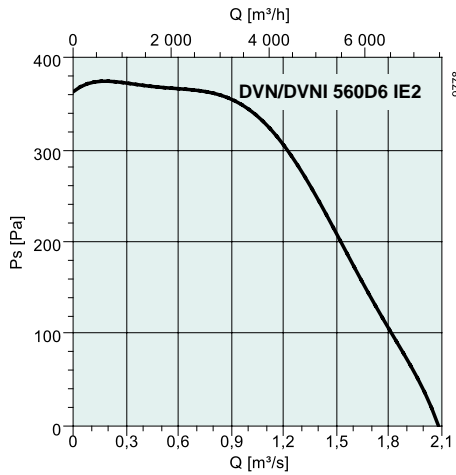

dB(A)	Tot	Frequency bands [Hz]							
		63	125	250	500	1k	2k	4k	8k
L _{WA} Inlet	70	57	59	64	65	65	61	56	48
L _{WA} Surrounding	72	59	61	66	67	67	63	58	50
DVNI									
L _{WA} Surrounding	63	56	56	59	56	53	44	42	34
With SSD 560/630									
L _{WA} Inlet	61	55	54	56	54	48	40	37	35

Measurement point: 1,1 m³/s; 340 Pa

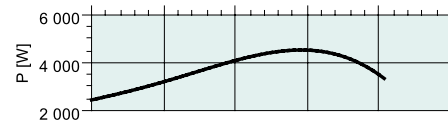
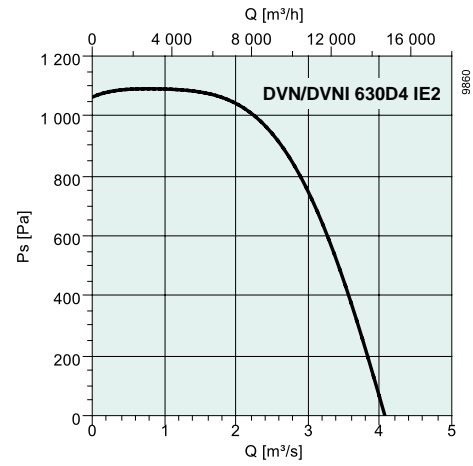

dB(A)	Tot	Frequency bands [Hz]							
		63	125	250	500	1k	2k	4k	8k
L _{WA} Inlet	87	74	76	80	82	81	78	73	66
L _{WA} Surrounding	89	76	78	82	84	83	80	75	68
DVNI									
L _{WA} Surrounding	80	73	73	75	73	69	61	59	52
With SSD 560/630									
L _{WA} Inlet	78	72	71	72	71	64	57	54	53

Measurement point: 3,06 m³/s; 600 Pa

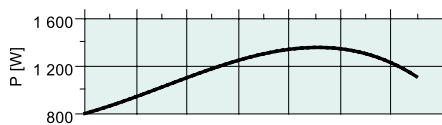
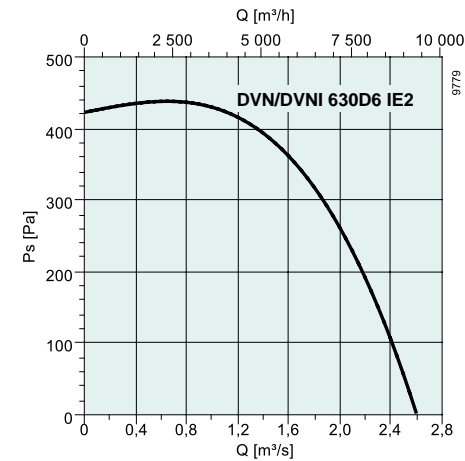

dB(A)	Tot	Frequency bands [Hz]							
		63	125	250	500	1k	2k	4k	8k
L _{WA} Inlet	74	61	63	68	69	69	65	60	52
L _{WA} Surrounding	76	63	65	70	71	71	67	62	54
DVNI									
L _{WA} Surrounding	67	60	60	63	60	57	48	46	38
With SSD 560/630									
L _{WA} Inlet	65	59	58	60	58	52	44	41	39

Measurement point: 3,06 m³/s; 600 Pa

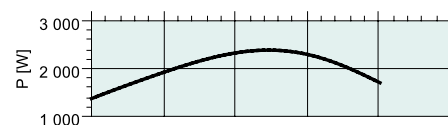
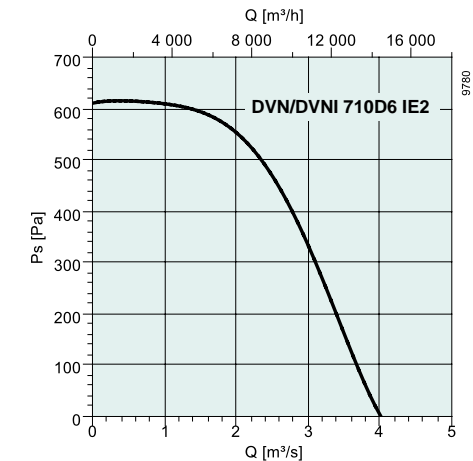

dB(A)	Tot	Frequency bands [Hz]							
		63	125	250	500	1k	2k	4k	8k
L _{WA} Inlet	79	66	68	73	74	74	70	65	57
L _{WA} Surrounding	81	68	70	75	76	76	72	67	59
DVNI									
L _{WA} Surrounding	72	65	65	67	65	62	53	51	44
With SSD 710									
L _{WA} Inlet	69	63	62	65	60	54	45	42	41

Measurement point: 2,93 m³/s; 400 Pa