

Air dehumidification unit with cross counterflow plate heat exchanger and heat pump



Automatically selects the most economical operating mode!

Drysolair 11

AIR VOLUME FLOW: 1,000 – 6,000 m³/h



Drysolair 11 T5 01 - simplified illustration

At a glance:

- ▶ For all drying applications
- ▶ Low connection capacity due to an upstream installation of a recuperator
- ▶ Corrosion-free cross counterflow plate heat exchanger made from polypropylene
- ▶ Energy-saving EC fans
- ▶ Intelligent air bypass duct
- ▶ Compact design
- ▶ Integrated control and regulation system, compatible with all conventional building management systems

Units in the Drysolair 11 series were developed especially for discharging high levels of internal moisture to the atmosphere. Through the pre-cooling in the recuperator of the air to be dried, the unit works with considerably lower compressor performance than a simple heat pump system and creates a con-

sistently good climate in ice rinks, the drying of buildings or industrial drying processes. The combination of first-class components with precise control and regulation guarantees economical operation at all times and adjusts the temperature and humidity to requirements.

Further performance parameters and options:

- Specific power consumption of less than 500 Wh/kg dehumidification capacity
 - Air filtration
 - corrosion-free heat exchanger made from polypropylene
 - Individually controllable performance parameters
 - Complete unit, ready to connect, contains all structural elements for comfort air conditioning, including all control and regulation fittings
 - Intensive quality inspection with factory test run
- Options
- Indoor air humidity regulation
 - Warm water condenser
 - Remote maintenance
 - And many more

Functional description

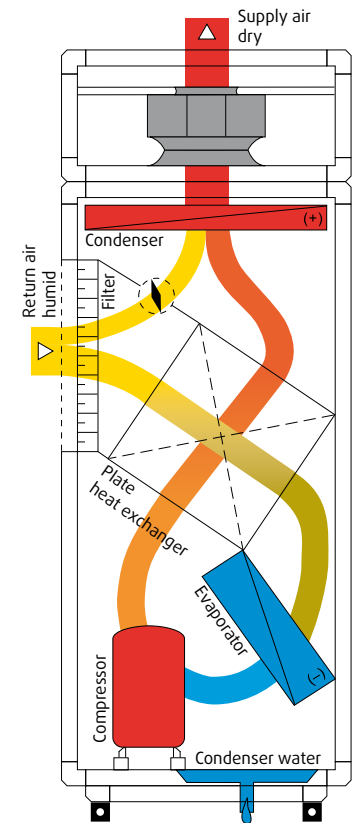

Recirculation mode

In recirculation mode humid air is dehumidified in two stages and supplied into the room as dry supply air. The return air is pre-cooled and dehumidified in the plate heat exchanger.

The dehumidification to the desired supply air humidity level takes place by means of cooling the air to below its dew point in the evaporator of the heat pump. The air that has been dried in this manner is then warmed back up again in the condenser of the heat pump using its own heat, which was removed during cooling, and is brought to the required condition.

The pre-cooling in the plate heat exchanger of the air to be dried means that the air dehumidification unit operates with a considerably lower compressor performance and hence a significantly lower energy consumption than a simple heat pump solution. The integrated bypass allows fast and precise control and adjustment to the condition of the return air. The cooling capacity is thus continuously adapted to the respective requirements.

Specific dehumidification energy requirement

Drysolair achieves a specific dehumidification energy requirement of far less than 500 Wh/kg. With one kilowatt hour of electrical energy, it is therefore possible to remove more than 2 kg of humidity from the recirculation air. In contrast, classical solutions without integrated heat recovery systems reach peak values in excess of 1,000 Wh/kg.

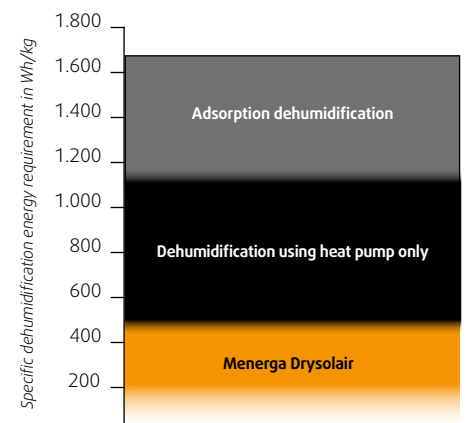

Drysolair Type 11

System dimensions and weights

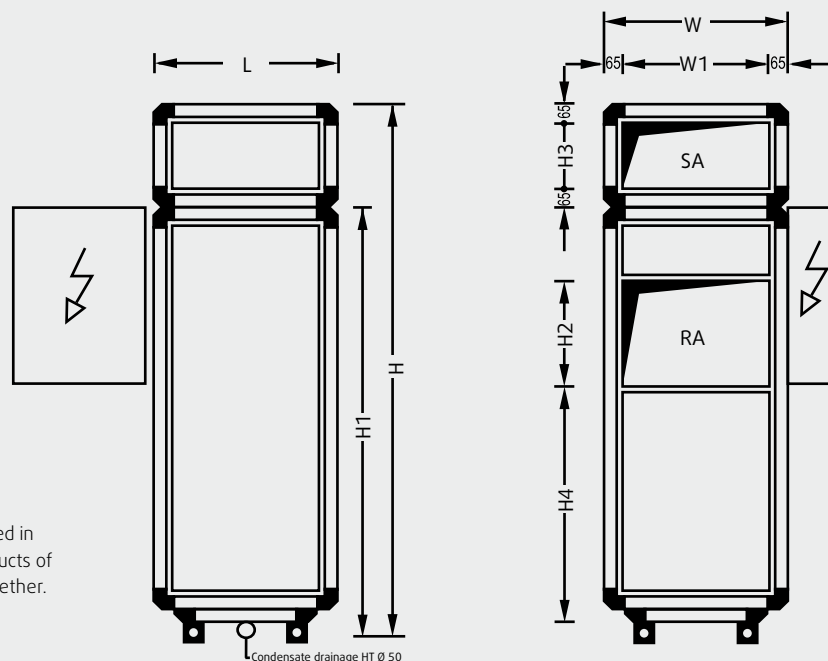

Important! Where a system is operated in parallel, the supply air and return air ducts of the two units have to be brought together.

Mirror-image design possible.

Unit feet 100 mm

Optional: adjustable feet from 100 to 120 mm

Unit type	L	W ¹	H ²	W1	H1	H2	H3	H4	Weight
11 10 01	730	730	2,245	600	1,755	440	360	910	450
11 15 01	730	730	2,245	600	1,755	440	360	910	450
11 40 01	1,050	1,050	2,725	920	2,155	580	440	1,200	660
11 60 01	1,050	1,050	2,725	920	2,155	580	440	1,200	680

Drysolair

Largest transport unit

Unit Type	L	W	H ²	Weight
11 10 01	730	730	1,655	300
11 15 01	730	730	1,655	300
11 40 01	1,050	1,050	2,055	500
11 60 01	1,050	1,050	2,055	500

Controls cabinet

Unit Type	H x W x D	Position at unit
11 10 01	900 x 480 x 210	SA/RA side
11 15 01	900 x 480 x 210	SA/RA side
11 40 01	900 x 480 x 210	SA/RA side
11 60 01	900 x 480 x 210	SA/RA side

For service work, a clearance corresponding to dimension W is required on the operating side of the unit. If dimension W is smaller than one metre, please leave a clearance of one metre.

Please comply with the dimensions for body size, air duct connections and electrical switch cabinet.

All lengths are given in mm, weights in kg, weight incl. Controls cabinet.

- 1 Door fitting assembly increase unit width by 25 mm each operating side
- 2 incl. 100 mm unit feet

Technical specifications and services

Unit Type		11 10 01	11 15 01	11 40 01	11 60 01
Optimum flow rate	m ³ /h	1,000	1,500	4,000	6,000
Air inlet 20°C / 70% r.h. ¹					
Dehumidification capacity	kg/h	4.2	6.6	17.5	21.5
Heating capacity	kW	4.4	7.3	18.3	23.2
Specific dehumidification energy requirement	Wh/kg	386	439	386	453
Total power rating ²	kW	1.6	2.9	6.8	9.7
Compressor rated input	kW	1.2	2.3	5.5	7.1
Fan motor power rating ³	kW	0.4	0.6	1.3	2.6
SFP category		3	3	3	4
refrigerant type		R407C ⁴			
Air inlet 10°C / 85% r.h. ¹					
Dehumidification capacity ⁵	kg/h	2.8	4.3	11.2	14.5
Heating capacity	kW	2.8	4.2	10.7	14.6
Specific dehumidification energy requirement	Wh/kg	364	347	327	426
Total power rating	kW	1.0	1.5	3.7	6.2
Compressor rated input	kW	0.6	0.9	2.4	3.3
Fan motor power rating ³	kW	0.4	0.6	1.3	2.9
SFP category		3	3	3	3
refrigerant type		R134a ⁴			
General specifications					
Current consumption ²	A	8.7	11.5	18.5	24.4
Operating voltage		3 / N / PE 400 V 50 Hz			
External pressure loss					
Supply and return air channel	Pa	300	300	300	300
Sound power level ⁶					
Supply air vent	dB(A)	74	74	70	76
RA connection	dB(A)	68	68	62	68
Acoustic pressure at a distance of 1 m from the device ⁶	dB(A)	54	54	50	56
Filling volume for refrigerant type	kg	3.5	3.5	9.0	9.0
Connections					
Condensate drainage	DN	25	25	25	25

All technical data relate to optimum flow rate through heat recovery system and the air inlet conditions specified above

- 1 other designs available upon request
- 2 dependent on configuration of measurement and control system/unit
- 3 with average filter contamination
- 4 the refrigerant type used is dependent on the application/return air conditions/design conditions
- 5 reduction of the dehumidification capacity during defrosting intervals to be taken into account
- 6 at 250 Hz mid-band frequency

Please seek approval of technical data and specifications prior to start of the planning process.