

## Heat recovery from waste water with counterflow coaxial recuperator and heat pump



Automatically selects the most economical operating mode!

# AquaCond 44

QUANTITY OF FLOW: 0.8 – 5.4 m<sup>3</sup>/h



AquaCond 44 08 21 - simplified illustration  
Picture shows special equipment heat recovery bypass

### At a glance:

- ▶ **Heat recovery from clean or contaminated waste water for heating fresh water**
- ▶ **Reduction of energy required to heat the fresh water by up to 90%**
- ▶ **Automatic heat exchanger cleaning**
- ▶ **Flow rate regulation**
- ▶ **Integrated control and regulation system, compatible with all conventional building management systems**

Far too often, warm waste water is discharged into the sewer system, together with all the energy it contains. Units in the AquaCond 44 series recover the majority of this heat energy and transfer it to the fresh water. The combination of recuperator and heat pump means that only approx. 10% of the energy is required that would be needed by a conventional heating system. The heat exchanger cleaning system integrated

in this series even allows the units to be used where the waste water is contaminated. Recovering valuable energy – anytime when warm waste water is produced and simultaneously warm fresh water has to be provided, e.g. in the shower areas of swimming pools, hospitals or residential homes, in laundries and in many other industrial processes.

### Further performance parameters and options:

- Uniform pipe cross-sections throughout the waste water ducts for constant flow velocities
  - Heat pump system with fully sealed suction gas-cooled coolant compressor, mounted on vibration dampers
  - Complete unit, ready to connect, contains all structural elements for heat recovery from waste water, including all control and regulation fittings
  - Intensive quality inspection with factory trial run
- Options
- Additional pre-filtration of the waste water with coarse filters
  - Design of the heat exchanger as a safety heat exchanger, for additional separation of fresh and waste water
  - Recuperator bypass
  - And many more

## Functional description

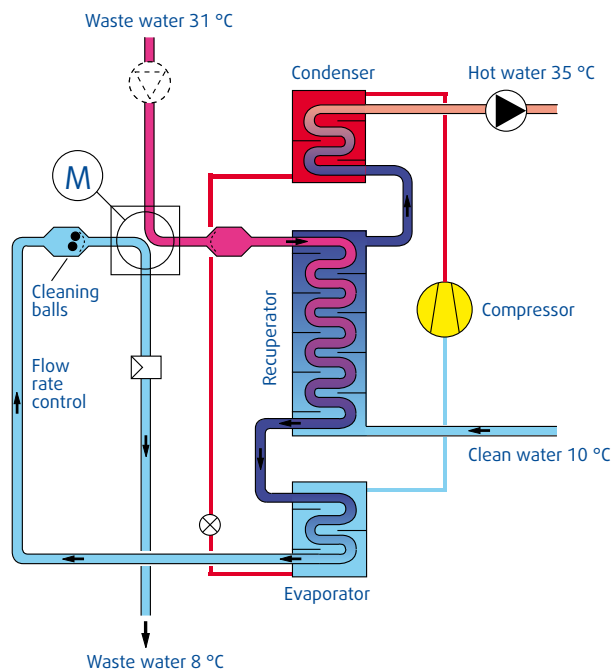

## Cleaning phase

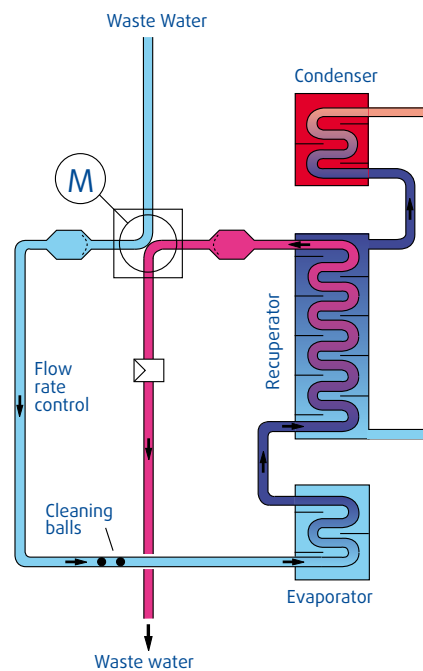

The principle of an AquaCond unit is to heat cold clean water to process water temperature in an energy-efficient manner. The heat source used is energy from warm waste water. The transmission of heat takes place through the combination of a recuperative heat exchanger with a heat pump.

In the first stage, the warm waste water flows through the recuperator and then passes through the evaporator of the heat pump. In counterflow and physically separated, the same volume of fresh water first passes through the recuperator and then through the condenser of the heat pump. In the recuperator, the majority of the heat contained in the waste water is transferred to the cold fresh water. This process takes place by means of the efficient counterflow principle and requires no energy input whatsoever.

In the evaporator of the heat pump, a further part of the heat is utilized from the waste water. In the condenser of the heat pump it is transferred to the already pre-heated fresh water. Thanks to the optimal design of the individual components, a total efficiency score of 11 is achieved.

Uniform pipe cross-sections in the waste water ducts guarantee uniformly high flow velocities. This means that the design reduces deposits of contaminants in the heat exchanger pipes and hence any worsening of the heat exchanger efficiency rating. Despite the uniform flow rates, there is a possibility that soap, grease and other substances dissolved in the warm waste water could be deposited on the exchange surfaces during the cooling phase. If the waste water is organically contaminated, bacteria

growth and organic sludge formation will possibly adhere to the surface of the heat exchanger. In order to prevent this, the automatic heat exchanger cleaning system regularly passes cleaning pellets through the waste water ducts. The cleaning pellets loosen the deposits from the pipes and prevent the formation of layers on the surfaces.

# AquaCond Type 44

## System dimensions and weights

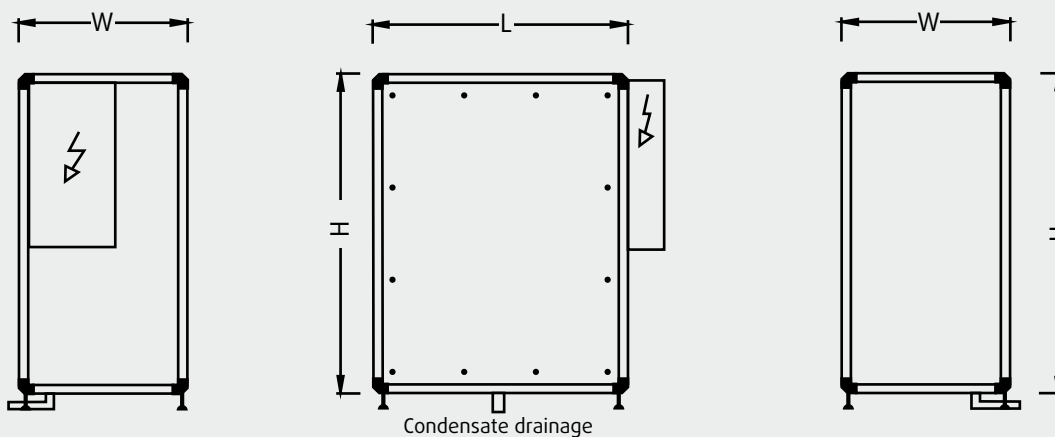

Unit feet 100 mm

Optional: adjustable feet from 100 to 120 mm

Unit Type	L	W <sup>1</sup>	H <sup>2</sup>	Weight
44 08 .1	1,050	730	1,370	430
44 12 .1	1,210	890	1,530	450
44 18 .1	1,370	890	1,690	650
44 24 .2	2,420	890	1,530	860
44 36 .2	2,740	890	1,690	1,260
44 54 .3	4,110	890	1,690	1,900

AquaCond

### Largest transport unit

Unit Type	L	W	H <sup>2</sup>	Weight
44 08 .1	1,050	730	1,370	430
44 12 .1	1,210	890	1,530	450
44 18 .1	1,370	890	1,690	650
44 24 .2	1,210	890	1,530	460
44 36 .2	1,370	890	1,690	660
44 54 .3	1,370	890	1,690	700

### Controls cabinet

Unit Type	H x W x D	Position at unit
44 08 .1	900 x 480 x 210	front side right
44 12 .1	900 x 480 x 210	front side right
44 18 .1	900 x 480 x 210	front side right
44 24 .2	1,120 x 640 x 210	front side right
44 36 .2	1,120 x 640 x 210	front side right
44 54 .3	1,600 x 640 x 250	front side right

Please comply with the dimensions for body size and electrical switch cabinet.

All lengths are given in mm, weights in kg, weight incl. Controls cabinet.

- 1 Door fitting assembly increase unit width by 25 mm each operating side
- 2 plus unit feet

All pipes to be fitted with locking devices onsite.

## Technical specifications and services

Unit Type		44 08 .1	44 12 .1	44 18 .1	44 24 .2	44 36 .2	44 54 .3
Max. quantity of flow	m <sup>3</sup> /h	0.8	1.2	1.8	2.4	3.6	5.4
Heating capacity	kW	25	37	52	74	104	156
Rated compressor input	kW	1.8	2.6	3.4	2 x 2.6	2 x 3.4	3 x 3.4
Combined COP <sup>1</sup>		10.8	11.4	11.8	11.5	11.6	11.8
Filling volume for refrigerant type R407C	kg	3.0	4.0	5.0	8.0	10.0	15.0
Max. connection capacity	kW	4.0	6.4	9.6	13.0	20.0	29.0
Operating voltage		3 / N / PE 400 V 50 Hz					
Residual delivery head on clean water side	kPa	5	5	5	5	5	5
Pressure loss on waste water side	kPa	80	90	90	95	95	98
<b>Connections</b>							
Waste water	mm	32	32	40	40	50	50
Clean water CU	mm	22	22	28	28	35	35
Clean water PVC	mm	32	32	32	40	50	50

Technical data specified refer to max. volume flow rate and waste water temperature 31°C / clean water temperature 10°C

<sup>1</sup> Power consumption including process water pump and external waste water pump

Please seek approval of technical data and specifications prior to start of the planning process.

### Material key \*

Key	Waste water heat exchanger	Waste water side piping	Clean water heat exchanger	Clean water side piping
44 .. 0.	Cu	PVC	Cu	Cu
44 .. 1st	Cu	PVC	Cu tin-plated	PVC
44 .. 2.	Cu-Ni-10Fe	PVC	Cu	Cu
44 .. 3rd	Cu-Ni-10Fe	PVC	Cu tin-plated	PVC

\* Cu-Ni-10Fe for aggressive waste water (e.g. swimming pool waste water)  
Cu tin-plated, if the clean water installation downstream of the unit is made of galvanised steel pipe