

Brine/Water

Professional

Heat pumps

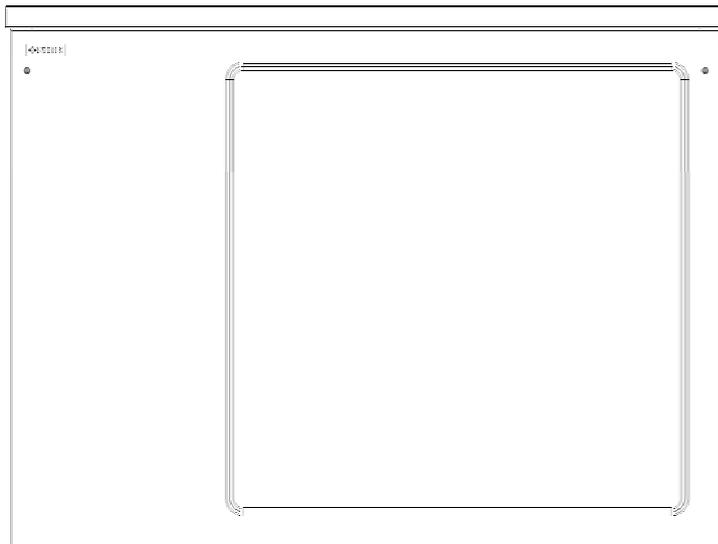

NIBE AP-BW30



Please read first

This operating manual provides important information on the handling of the unit. It is an integral part of the product and must be stored so that it is accessible in the immediate vicinity of the unit. It must remain available throughout the entire service life of the unit. It must be handed over to subsequent owners or users of the unit.

In addition to this operating manual, you must also have the operating manual for the heating and heat pump regulator and the operating manual for your heat pump.

Read the operating manual before working on or operating the unit. This applies in particular to the chapter on safety. Always follow all instructions completely and without restrictions.

It is possible that this operating manual may contain instructions that seem incomprehensible or unclear. In the event of any questions or if any details are unclear, contact the factory customer service department or the manufacturer's local partner.

Since this operating manual was written for several different models of the unit, always comply with the parameters for the respective model.

This operating manual is intended only for persons assigned to work on or operate the unit. Treat all constituent parts confidentially. The information contained herein is protected by copyright. No part of this manual may be reproduced, transmitted, copied, stored in electronic data systems or translated into another language, either wholly or in part, without the express written permission of the manufacturer.

Symbols

The following symbols are used in the operating manual. They have the following meaning:



Information for operators.



Information or instructions for qualified personnel.



DANGER!

Indicates a direct impending danger resulting in severe injuries or death.



WARNING!

Indicates a potentially dangerous situation that could result in serious injuries or death.



CAUTION!

Indicates a potentially dangerous situation that could result in medium or slight injuries.



ATTENTION.

Indicates a potentially dangerous situation, which could result in property damage.



NOTE.

Emphasized information.



ENERGY SAVING TIP

Indicates suggestions that help to save energy, raw materials and costs.



Reference to other sections of the operating manual.



Reference to other documents of the manufacturer.



Inhaltsverzeichnis

INFORMATION FOR USERS AND QUALIFIED PERSONNEL

PLEASE READ FIRST	2
SYMBOLS	2
INTENDED USE	4
DISCLAIMER.....	4
EC CONFORMITY	4
SAFETY	4
CUSTOMER SERVICE	5
WARRANTY / GUARANTEE	5
DISPOSAL	5
OPERATING PRINCIPLE OF HEAT PUMPS.....	5
AREA OF UTILISATION.....	5
HEAT METERING	6
OPERATION.....	6
CARE OF THE UNIT.....	6
MAINTENANCE OF THE UNIT	6
Cleaning and flushing of unit components.....	7
MALFUNCTIONS.....	7

INSTRUCTIONS FOR QUALIFIED PERSONNEL

SCOPE OF DELIVERY	7
INSTALLATION	8
Installation area.....	8
Transport to installation location.....	8
Installation.....	9
INSTALLATION OF THE HYDRAULIC CONNECTIONS	10
Buffer tank	10
Domestic water heating.....	10
Domestic hot water tank	10
Installing the housing.....	12
ELECTRICAL CONNECTIONS	14
INSTALLATION OF THE CONTROL ELEMENT	16
FLUSHING AND FILLING THE UNIT	16
flushing and filling the heat source.....	17
flushing and filling the heating circuit	17
INSULATING THE HYDRAULIC CONNECTIONS	19
COMMISSIONING	19
DISMANTLING	19

TECHNICAL DATA / SCOPE OF DELIVERY

AP-BW30-37-69, AP-BW30-29H-56H	20
--------------------------------------	----

PERFORMANCE CURVES

AP-BW30-37.....	22
AP-BW30-45	23
AP-BW30-58.....	24
AP-BW30-69.....	25
AP-BW30-29H.....	26
AP-BW30-56H	27

DIMENSIONAL DRAWINGS AND INSTALLATION PLANS

AP-BW30-37 to AP-BW30-69	
Dimensional drawings - moving dimensions.....	28
Dimensional drawings with housing	29
AP-BW30-29H to AP-BW30-56H	
Dimensional drawings - moving dimensions.....	30
Dimensional drawings with housing	31

INSTALLATION PLAN

AP-BW30-37 to 69, AP-BW30-29H to AP-BW30-56H32	
AP-BW30-37 to 69, AP-BW30-29H- to 56H	33

TERMINAL DIAGRAM.....

AP-BW30-37 to 69, AP-BW30-29H to 56H	34
--	----

CIRCUIT DIAGRAMS

AP-BW30-37, AP-BW30-45	35
AP-BW30-58, AP-BW30-69, AP-BW30-56H.....	38

APPENDIX

EC DECLARATION OF CONFORMITY	44
------------------------------------	----



Intended use

The unit may be used only for the intended purpose. This means:

- For heating.
- For domestic water heating.
- For cooling (active + passive through external hydraulics)

The unit may be operated only within its technical parameters.

 Overview “Technical data / scope of delivery”.



NOTE.

Notify the responsible power supply company of the use of a heat pump or heat pump system.

Disclaimer

The manufacturer is not liable for losses resulting from any use of the unit which is not its intended use.

The manufacturer's liability also expires:

- If work is carried out on the unit and its components contrary to the instructions in this operating manual.
- If work is improperly carried out on the unit and its components.
- If work is carried out on the unit which is not described in this operating manual, and this work has not been explicitly approved by the manufacturer in writing.
- If the unit or components in the unit have been altered, modified or removed without the explicit written consent of the manufacturer.

EC conformity

The unit bears the CE mark of conformity.

 EC declaration of conformity

Safety

The unit is safe to operate for its intended use. The construction and design of the unit conform to current state of the art standards, all relevant DIN/VDE regulations and all relevant safety regulations.

Every person who performs work on the unit must have read and understood the operating manual prior to starting any work. This also applies if the respective person has already worked with such a unit or a similar unit or has been trained by the manufacturer.

Every person who performs work on the unit must comply with the applicable accident prevention and safety regulations. This applies in particular to the wearing of personal safety gear.



DANGER!

**Risk of fatal injury due to electric shock!
All electrical connections must be carried out by qualified electricians only.**

Before opening the unit, disconnect the system from the power supply and prevent it from being switched back on!



WARNING!

Only qualified personnel (trained heating, cooling and refrigerant engineers and electricians) may carry out work on the unit and its components.



WARNING!

Observe safety labels on and in the unit.



WARNING!

**Unit contains refrigerants!
Leaking refrigerant could result in personal injury or material damage.
Therefore:**

- Switch off unit
- Thoroughly ventilate installation room
- Notify the manufacturer's authorised service centre



ATTENTION

For safety reasons:

Never disconnect the unit from the power supply, unless the unit is being opened.



Customer service

For technical information please contact your local heating engineer or the manufacturer's local partner.

 Overview "Customer service".

Warranty/Guarantee

For warranty and guarantee conditions, please refer to the purchase documents.

 **NOTE.**
Please contact your dealer about all matters concerning warranties and guarantees.

Disposal

When decommissioning the old unit, always comply with local applicable laws, directives and standards concerning the recovery, recycling and disposal of materials and components of cooling units.

 "Dismantling".

Operating principle of heat pumps

Heat pumps operate on the same principle as a refrigerator: same technology, only with reversed benefits. The refrigerator extracts heat from foods, which is released into the room through fins on the back.

The heat pump extracts heat from our environment: air, earth or ground water. The extracted heat is conditioned in the unit and supplied to the heating water. Even when it is extremely cold outside, the heat pump draws enough heat to heat a house.

Example: drawing of a brine/water heat pump with floor heating:

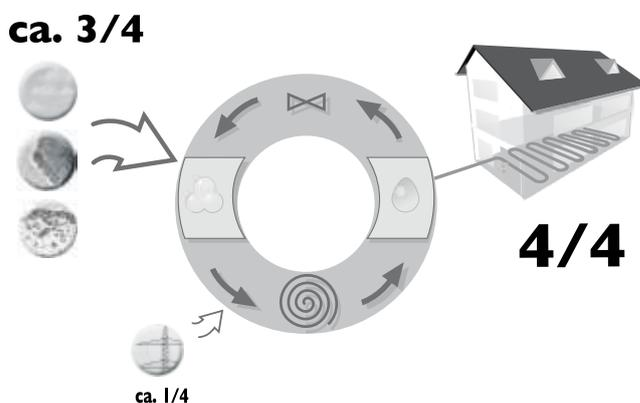

$\frac{4}{4}$ = usable energy
 approx. $\frac{3}{4}$ = environmental energy
 approx. $\frac{1}{4}$ = external electrical energy

Area of utilisation

Taking into consideration the ambient conditions, limits of application and the applicable regulations, every heat pump can be utilised in new or existing heating systems.

 Overview "Technical data / scope of delivery".



Heat metering

In addition to proof of the unit's efficiency, the EEWaermeG also requires heat metering (hereafter referred to as HQR). Heat metering is mandatory for air/water heat pumps. Heat metering for brine/water and water/water heat pumps only have to be installed for a flow temperature $\geq 35^{\circ}\text{C}$. The heat metering must record the total thermal energy released (heating and domestic hot water) in the building. In heat pumps with heat metering, the analysis is carried out by the regulator. The regulator displays the thermal energy discharged in the heating system in kWh.

Operation

Your decision to purchase a heat pump or a heat pump system is a long-term contribution to protecting the environment through low emissions and reduced primary energy use.

To ensure that your heat pump or heat pump system operates efficiently and ecologically, the following are especially important:



ENERGY SAVING TIP

Avoid unnecessarily high flow temperatures. A lower flow temperature on the hot water side increases the efficiency of the system.



ENERGY SAVING TIP

Preferably use purge ventilation. Compared to continuously open windows, it is better to air rooms by fully opening windows for a short period, two to three times a day (so-called "rapid" or "purge" ventilation); this reduces energy consumption and your heating bill.

You can operate and control the heat pump system with the control element of the heating and heat pump regulator.



NOTE.

Make sure that the control settings are correct.



Operating manual of the heating and heat pump regulator.

Care of the unit

The outer surfaces of the unit can be cleaned with a damp cloth and standard cleaning products.

Do not use cleaning or care products that contain abrasives, acids and/or chlorine. Such products would destroy the surfaces and could also damage the technical components of the unit.

Maintenance of the unit

The cooling circuit of the heat pump requires no regular maintenance.

According to EU regulation (EC) 842/2006 of May 17, 2006, leak inspections and maintenance of a log book are required for certain heat pumps!

The criteria for conducting leak inspections and maintaining a log book are based on the hermetic impermeability of the cooling circuit and the refrigerant capacity of the heat pump! No log book is required for heat pumps with a refrigerant capacity of $< 3\text{kg}$. With all other heat pumps, the log book is included with all other delivered materials.



Log book for heat pumps, Section "Information on use of the log book".

The components of the heating circuit and the heat source (valves, expansion vessels, circulating pumps, filters, dirt traps) should be inspected and cleaned as needed - at the very least annually - by qualified personnel (heating or cooling system fitters).

It is best to arrange a maintenance agreement with a heating installation company. The company will arrange for the required maintenance at regular intervals.



CLEANING AND FLUSHING OF UNIT COMPONENTS



CAUTION!

Unit components may be cleaned and flushed only by customer service personnel authorised by the manufacturer. Use only liquids recommended by the manufacturer.

Flushing of the liquefier with chemical cleaning agents must be followed by neutralisation of residue and intensive flushing with water. Always observe the technical data of the manufacturer of the heat exchanger.

Malfunctions

In the event of a fault, you can read out the cause of the fault from the diagnostic program of the heating and heat pump regulator.



Operating manual of the heating and heat pump regulator.



WARNING!

Only customer service personnel authorised by the manufacturer may carry out service and repair work on the components of the unit.



Overview "Customer service".

Scope of delivery

Example of scope of delivery:

Size I:

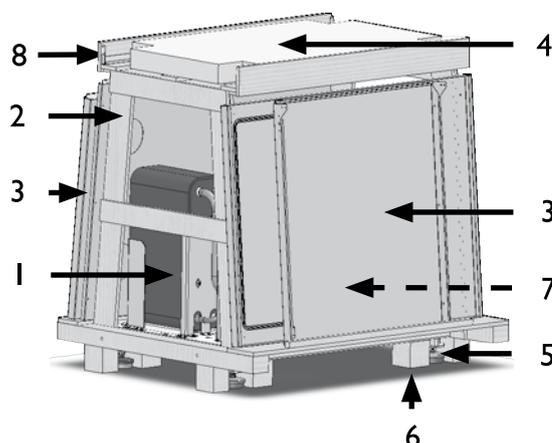

As delivered:

- 1 Heat pump = complete indoor unit
- 2 Transport frame
- 3 Facing panels placed to the side (5 panels)
- 4 Insulation panel, which is then pushed under the baseplate (sound insulation)
- 5 Pre-fitted adjustable feet (4)
- 6 Spacer blocks (4), which can be unscrewed after installation
- 7 Extra box with accessories (indoors)
- 8 Profile rails

Complete the following first:

- ① Check the delivery for outwardly visible signs of damage...
- ② Check that nothing is missing from the scope of supply...
Any defects or incorrect deliveries must be reported immediately.



NOTE.

Note the unit model.



Overview "Technical data / scope of delivery".



Installation

Observe the following when performing all work:

NOTE.
Always comply with the applicable local accident prevention regulations, statutory regulations, ordinances, guidelines and directives.

WARNING!
The heat pump or heat pump system may only be installed and assembled by qualified personnel!

NOTE.
Observe the sound levels of the respective model.

Overview “Technical data/scope of delivery”, “Sound” section.

INSTALLATION AREA

ATTENTION
Install the heat pump only indoors.
The installation room must be frost-free and dry.

WARNING!
Please note and follow the respective relevant local standards, directives and regulations applicable, especially the minimum volume necessary depending on the refrigerant capacity of the relevant heat pump system (EN 378-1).

Refrigerant	Limit
R 134a	0.25 kg/m ³
R 404A	0.48 kg/m ³
R 407C	0.31 kg/m ³
R 410A	0.44 kg/m ³

Overview “Technical data/scope of delivery”, “General unit data” section.

$$\text{Minimum volume} = \frac{\text{Refrigerant capacity [kg]}}{\text{Limit [kg/m}^3\text{]}}$$

NOTE.
If several heat pumps of the same type are installed, only one heat pump must be considered.
If several heat pumps of different types are installed, the heat pump with the largest refrigerant capacity must be considered.

TRANSPORT TO INSTALLATION LOCATION

① Before transporting the heat pump to the final installation location the packaging and wooden frame can be dismantled.
To do this, remove the facing panels on the long sides, undo the wooden boards and remove the two machine screws (M8) in each of the sides.

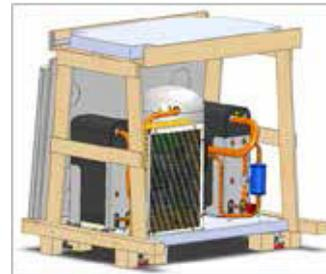

② You can now lift the unit with the help of a pallet truck or fork lift truck and transport it to its final installation location.

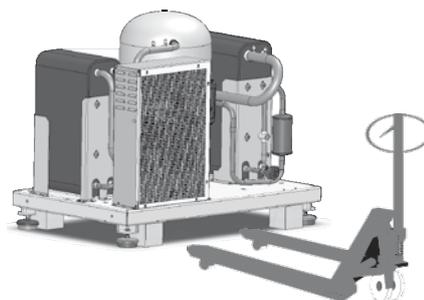

NOTE.
The unit has ground clearance for easy access from all sides

NOTE.
The baseplate is 76 cm wide, so that the heat pump can be transported through a standard door opening.



NOTE.
Keep the components enclosed in the scope of delivery in a safe place until the assembly.

Always comply with the following safety information during transport:

CAUTION!
Wear safety gloves.

WARNING!
Several people are required to transport the unit. Do not underestimate the weight of the unit.

Overview “Technical data/scope of delivery”, “General unit data” section.

CAUTION!
Make sure to secure unit against slipping during transport.

ATTENTION
Never use components and hydraulic connections on the unit for purposes of transport.

Do not damage the hydraulic connections under any circumstances.

ATTENTION
Do not tilt the unit more than a maximum of 45° (in any direction).

INSTALLATION

WARNING!
Several people are required to install the unit.

NOTE.
Take into account the size of the unit.

Overview “Technical data/scope of delivery”, “General unit data” section.

NOTE.
Always follow the installation plan for the respective model. Note the size and minimum clearances.

Installation plan for respective model.

ATTENTION
The heat pump must be installed on a firm, horizontal surface. Make sure that the foundation is designed for the weight of the heat pump.

Do not use a rigid foam boiler pedestal!

Overview “Technical data/scope of delivery”, “General unit data” section.

NOTE.
Set up the unit so that the operating side is accessible at all times!

ATTENTION
Do not tilt the unit more than a maximum of 45° (in any direction).

- Lower the basic heat pump module on the 4 wooden transport blocks in its final installation location. Now use the vibration-decoupling, adjustable machine feet to align the unit horizontally. Ensure the distance from the finished floor level to the top of the heat pump baseplate is 170 mm. Lock this setting by locking the nuts.



- The four transport blocks (each with 2 universal wood screws) must then be removed.



Installation of the hydraulic connections

BUFFER TANK

The hydraulic connection of the heat pump requires a buffer tank in the heating circuit. The required volume of the buffer tank is calculated based on the following formula:

$$V_{\text{Buffer tank}} = \frac{\text{minimum flow rate of heat circuit volume flow / hour}}{10}$$



For the minimum flow rate of the heat circuit volume flow, see overview “Technical data/ Scope of delivery”, “Heating circuit” section.

DOMESTIC WATER HEATING

The domestic water heating with the heat pump requires an additional hot water circuit, parallel to the heating circuit. When installing, make sure that the domestic hot water charge is not fed through the buffer tank of the heating circuit.



“Hydraulic connection” instructions.

DOMESTIC HOT WATER TANK

If the heat pump is to be used for domestic water heating, you must integrate special domestic hot water tanks in the heat pump system. Choose a storage volume so that the required quantity of hot water is available even during a power cut.



NOTE:

The heat exchanger surface of the domestic hot water tank must be dimensioned so that the heating capacity of the heat pump is transferred with minimum spread.

We offer a variety of domestic hot water tanks for you to choose from. They are optimised for use with your heat pump.



ATTENTION

Connect the unit to the heating circuit according to the hydraulic diagram for the respective model.



“Hydraulic connection” instructions.



ATTENTION

The heat source system must be designed according to the specifications of the planning manual.



Planning manual and “Hydraulic connection” documents.



NOTE:

Check to make sure that the diameters and lengths of the pipes for the heating circuit and the heat source are sufficiently dimensioned.



NOTE:

Circulating pumps, which pump the volume flow through the heat pump, must be designed as multi-stage pumps. They must at least provide the minimum throughput rate required for your model.

In the case of heat source pumps, the viscosity of the brine liquid must also be taken into account!



Overview “Technical data/scope of delivery”, “Heat circuit” and “Heat source” sections.



ATTENTION

The hydraulic system must be equipped with a buffer tank, the required volume of which depends on the model of your unit.



ATTENTION

When installing the connections, always secure the connections on the unit against twisting, in order to prevent damage to the components inside the unit.



The following steps are to be carried out on all 4 hydraulic connections of the heat pump:

- ① Push the insulation elements included in the scope of delivery onto the plate heat exchanger

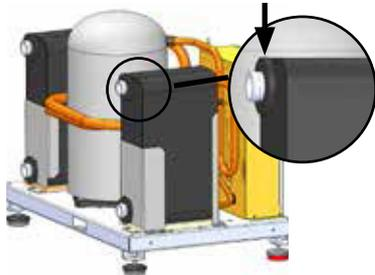

- ② Position the back panel of the heat pump on the basic heat pump module

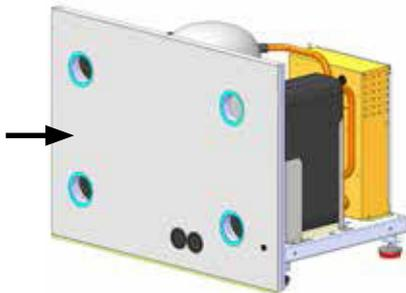

- ③ Connect the piece of pipe supplied to the threaded flange and insulate it with the enclosed insulating hose



- ④ Connect the connectors to the connection clip included in the scope of supply to the corresponding connection on the heat pump.

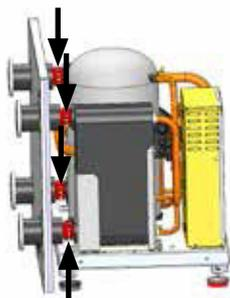

- ⑤ Use the insulating tape supplied to insulate the connection clip. Use the enclosed fastening materials to additionally fix the insulation.

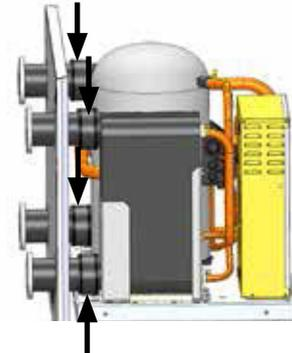

NOTE:
We recommend completing step ⑤ after the leak test.

NOTE:
The heat source and heating side must be insulated from the heat pump; to this end we recommend using the IPFK hydraulic connection set in our range of products (not included in the scope of delivery).

- ⑥ Install shut-off devices at the heating circuit.
- ⑦ Install shut-off devices at the heat source.
- ⑧ Place a bleeder at the highest point of the heat source in the heat source outlet...
- ⑨ We recommend installing a dirt filter (screen size 0.9 mm) on the heat source inlet connection...

The hot water and heat source connections are marked accordingly on the unit.

Hand icon: For the positioning of the connections, please refer to the dimensioned drawing for the respective model.



INSTALLING THE HOUSING

NOTE.
Remove the protective film from all facing panels.

NOTE.
The screws for installing the heat pump housing are included in the scope of delivery.

- ① Position the insulation included in the scope of delivery under the baseplate.

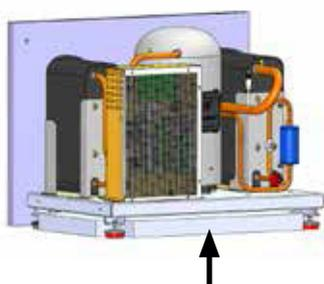

NOTE.
Before screwing on the side panels, feed the patch cable and + LIN bus cable through the rear panel!

see “electrical connection work”

- ② Screw the two side panels onto the back panel using 3 screws for each:

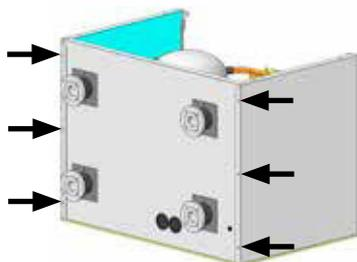

- ③ Mount the profile rail onto the front of the unit, between the two side panels, using 2 screws for each side.

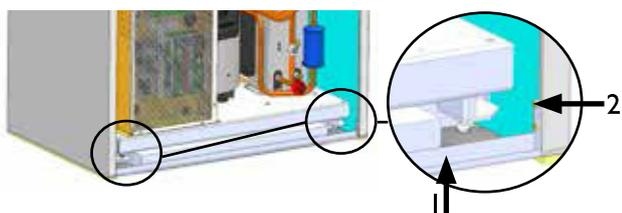

1 Profile rail
2 Screw

- ④ Align the facing with the baseplate as shown in the following sketch

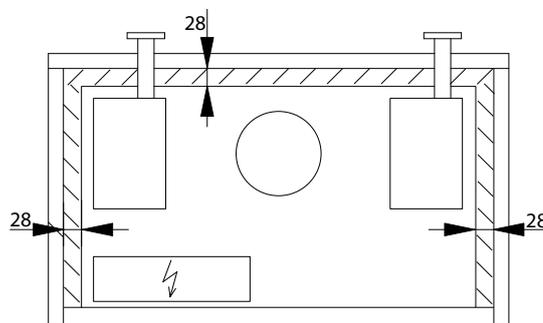

- ⑤ Secure and fix the facing on the profile rail using the fastening materials included in the scope of delivery (2 x 10mm anchors and 2 x M8 hanger bolts). Twist the hanger bolt into the floor up to the start of the thread.

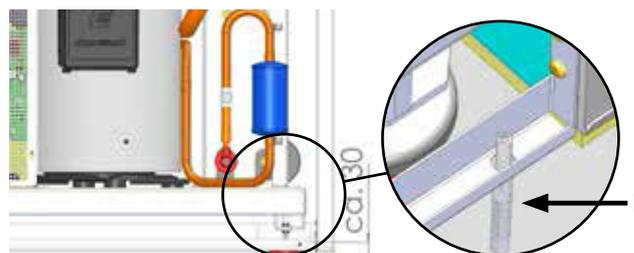

I hanger bolt with anchor

- ⑥ Align the insulating board under the unit with the middle of the unit (see ①).

- ⑦ Fix the housing cover onto the rear panel (5 screws):

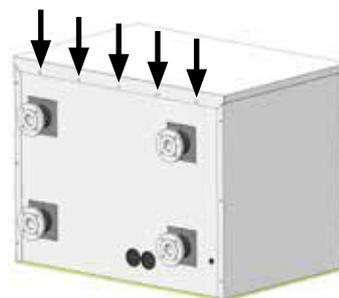

and the two side panels (2 screws each) onto the front:

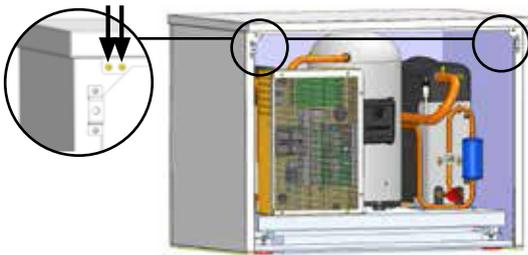

- ⑧ The front panel can now be hung into the clips provided at the bottom

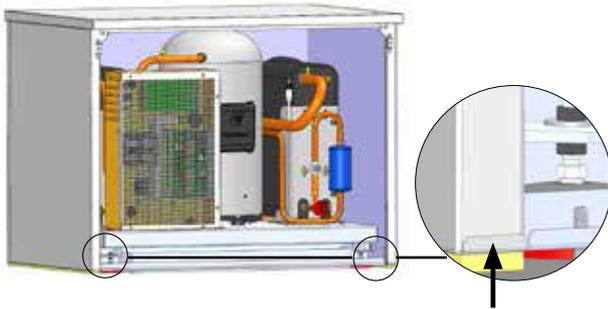

- ⑨ and locked by means of the two quarter-turn screws.

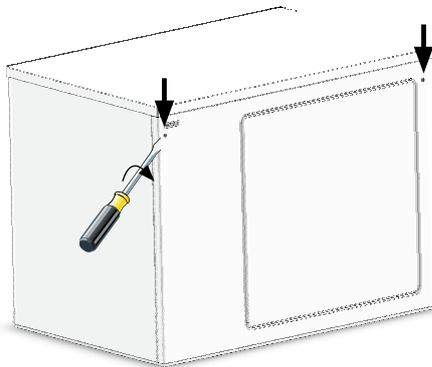

- ⑩ Glue the insulating half-shells included in the scope of delivery around the pipe pieces in the rear panel.

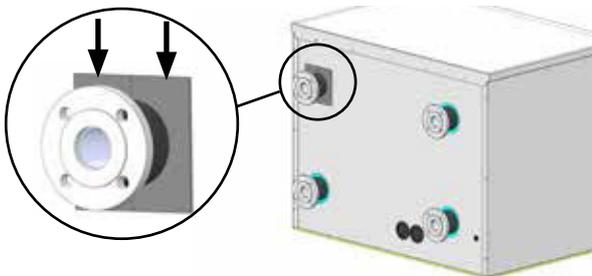



Electrical connections

The following applies to all work to be done:



DANGER!

**Risk of fatal injury due to electric shock!
All electrical connections must be carried out by qualified electricians only.**

Before opening the unit, disconnect the system from the power supply and prevent it from being switched back on!



WARNING!

During installation and while carrying out electrical work, comply with the relevant EN-, VDE and/or local safety regulations.

Comply with technical connection requirements of the responsible power supply company (if required by the latter)!



NOTE.

All cables must be fed through the openings in the back panel!

- ① The front panel is hung in at the bottom and is held in place at the top by 2 quarter-turn screws.

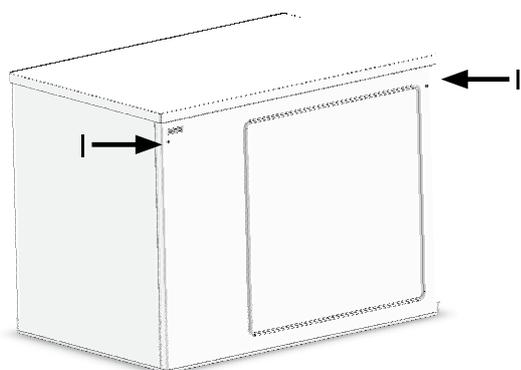

1 Quarter-turn screws

- ② Open the quarter-turn screws of the front panel by turning them through 90° anticlockwise...



- ③ Lift out front panel and set aside in a safe place...

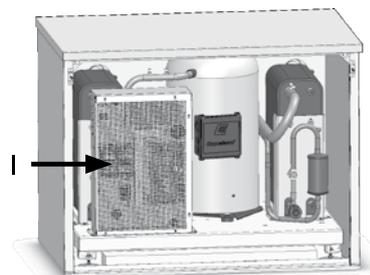

1 Electrical switch cabinet

- ④ Open the unit's electrical switch cabinet: Undo the 6 screws slightly, in order to unhook the cover panel by lifting it slightly...

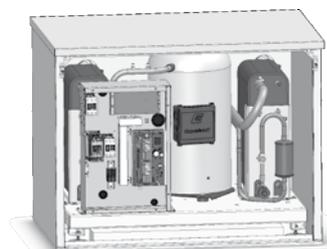

- ⑤ Several openings are provided at the back of the unit for passing through the cables:



NOTE.

When laying the cable, ensure that unshielded power supply cables and shielded cables (LIN bus) are laid separately from each other.



NOTE.

LIN bus length may not be increased. However, they can be shortened.



For further details, see "installation plan"

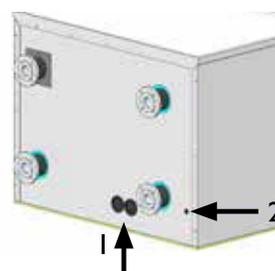

- 1 Electric cable penetration
- 2 Penetration, LIN bus and patch cable for heatpump controller



The external electric cables to be provided must be fed through the grommets cut out in the bottom of the rear panel and then fed into the electrical switch cabinet by means of the cable duct, which is integrated into the base-plate of the heat pump.

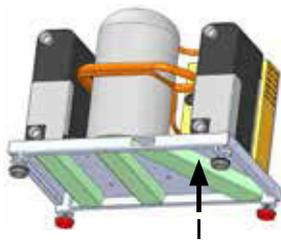

1 Cable duct

The cables laid in the switch cabinet for the regulator (patch cable, LIN bus) must be fed through the grommet cut out in the bottom of the rear panel.

⑥ Make electrical connections according to the terminal diagram...

 "Terminal diagrams" for respective model.

 **CAUTION**
Electrical connection work is only to be carried out according to the terminal diagram that applies to your model.

! ATTENTION
Ensure clockwise rotary field of the load power supply (compressor).
Operation with the incorrect rotary direction of the compressor can cause serious, irreparable damage to the compressor.

! ATTENTION
The power supply for the heat pump must be equipped with an all-pole automatic circuit-breaker with at least 3mm contact spacing to IEC 60947-2.
Note the level of the tripping current.

 Overview "Technical data/scope of delivery", "Electrics" section.

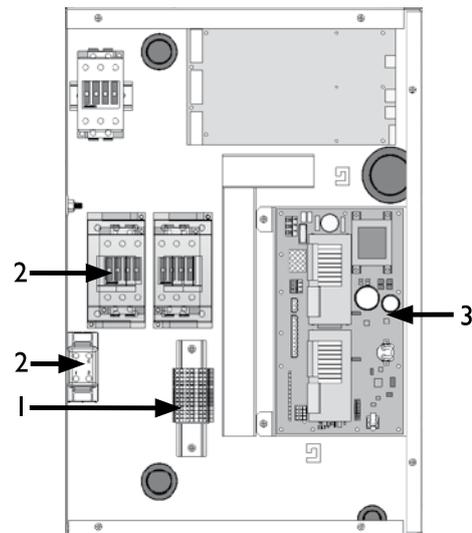

- 1 Control voltage connection
- 2 Compressor output connection
- 3 Regulator board

 **NOTE.**
The control element of the heat and heat pump regulator can be connected to a computer or network using a suitable network cable, enabling the heating and heat pump regulator to be controlled remotely from there.
If such a connection is required, lay a shielded network cable (category 6, with RJ-45 connector) up to the control element while carrying out the electrical connection work.

- ⑦ After completion of all electrical installation work, close the switch cabinet inside the unit.
- ⑧ Screw on the front panel of the unit if no further installation work inside the unit is to be performed immediately.



Installation of the control element



NOTE.

Note the distance between the control element and the unit.



For further details, see “installation plan”

Control element for wall-mounting

- ① Fasten the wall bracket using the assembly materials included in the scope of delivery.

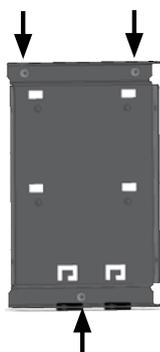

- ② There are 4 fixing hooks on the back of the control element.

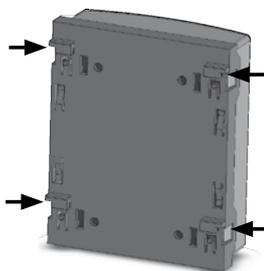

- ③ Hang the control element on the wall bracket using the 4 fixing hooks and push down until it latches into position.

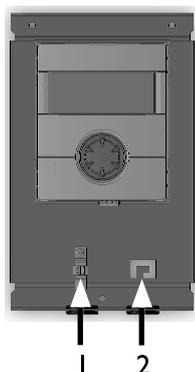

- 1 Shielded terminal for LIN bus cable/strain relief
2 Strain relief

- ④ Connection of patch cable and LIN bus cable to the regulator (via the strain relief):

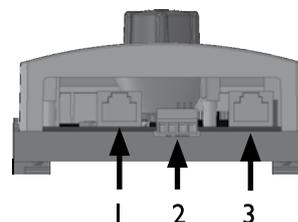

- 1 Patch cable to the network link
2 LIN bus to the regulator board in the unit
3 Patch cable to the regulator board in the unit

- ⑤ If the work on the heat pump regulator has been completed, the cover can be clipped onto the wall bracket.

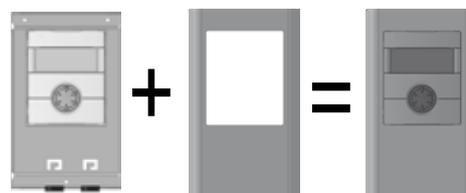

NOTE.

A connection to a computer or a network can be installed via the left bushing on the bottom of the control element, thus allowing the heating and heat pump regulator to be controlled remotely. This requires that a shielded network cable was laid up to the heat pump regulator during the electrical connection work.



Operating manual for the heating and heat pump regulator, version “Qualified heating engineers”, “Web server” section.



NOTE.

The network cable can be exchanged at any time. In order to be able to connect it, the screen must first be removed.

Flushing and filling the unit



ATTENTION

The system must be absolutely free from air before commissioning.



FLUSHING AND FILLING THE HEAT SOURCE

Contamination and deposits in the heat source can cause malfunctions.

! ATTENTION

Before flushing and filling the heat source the drain pipe of the safety valve must be connected
Important: do not discharge into the drains (anti-freeze mixture)!



NOTE.

Following antifreeze fluids are approved for the heat source circuit:

- Monopropylene Glycol
- Monoethylene Glycol
- Ethanol
- Methanol

! ATTENTION

With the use of (pipe-) materials, sealants and other components, the compatibility of materials with the antifreeze fluids must be assured!



WARNING!

Methanol and ethanol emit flammable and explosive gases. Furthermore, it is important to always regard the safety regulations of antifreeze fluids!

Proceed as follows:

- ① Flush heat source system thoroughly.
- ② Thoroughly mix the anti-freeze, available as an accessory, with water with the required ratio. Add only anti-freeze mixed with water to the heat source.

! ATTENTION

The concentration of anti-freeze in the water must be at the level specified for your model.



Overview "Technical data/scope of delivery", "Heat source" section.

- ③ Check the concentration of the anti-freeze in the mixture...
- ④ Fill heat source with the anti-freeze mixture...

- ⑤ Bleed the heat source.

FLUSHING AND FILLING THE HEATING CIRCUIT

WATER QUALITY OF THE FILL AND ADDITIONAL WATER IN HOT WATER HEATING SYSTEMS ACCORDING TO VDI 2035 PART I AND II

Use of modern, energy-efficient heat pump systems is becoming increasingly widespread. Their ingenious technology enables these systems to achieve very good efficiencies. The decreasing space available for heat generators has led to the development of compact units with increasingly smaller cross-sections and high capacities. This means the complexity of the systems and the material diversity are also increasing, which plays an important role especially in their corrosion behaviour. The heating water not only affects the efficiency of the system, but also the life of the heat generator and the heating components of a system.

The guide values of VDI 2035 Part I and Part II must therefore be complied with as minimum requirements for proper operation of the systems. Our practical experience has shown that the safest and most trouble-free running of the systems is achieved with so-called low-salt operation.

VDI 2035 Part I gives important information and recommendations regarding scaling and its prevention in heating and domestic hot water heating systems.

VDI 2035 Part II primarily deals with the requirements for reducing heating water corrosion in hot water heating systems.

PRINCIPLES OF PART I AND PART II

The occurrence of scaling and corrosion damage in hot water heating systems is low, if

- proper planning and commissioning is carried out
- the system is closed in corrosion terms
- adequately dimensioned pressurising is integrated
- the guide values for the heating water are complied with
- and regular servicing and maintenance are carried out.



A system log should be kept, in which the relevant planning data is entered (VDI 2035).

DAMAGE THAT CAN OCCUR IN CASE OF NON-COMPLIANCE

- Malfunctions and the failure of components (e.g. pumps, valves)
- Internal and external leaks (e.g. from heat exchangers)
- Cross-section reduction and blockaging of components (e.g. heat exchanger, pipes, pumps)
- Material fatigue
- Gas bubbles and gas cushion formation (cavitation)
- Negative effect on heat transfer (formation of coatings, deposits) and associated noises (e.g. boiling noises, flow noises)

LIMESCALE – THE ENERGY KILLER

Filling with untreated drinking water inevitably leads to the precipitation of all calcium as scale. The consequence: limescale deposits form on the heat transfer surfaces of the heating. The efficiency falls and the energy costs rise. A rule of thumb is that 1 millimetre of limescale deposit causes an energy loss of 10%. In extreme cases it can even cause damage to the heat exchangers.

WATER SOFTENING TO VDI 2035 – PART I

If the water is softened before the heating is filled, in accordance with the VDI 2035 guidelines, no scale can form. This effectively and permanently prevents limescale deposits and the resulting negative effects on the entire heating system.

CORROSION – AN UNDERESTIMATED PROBLEM

VDI 2035, Part II, deals with the problem of corrosion. Softening the heating water can prove to be insufficient. The pH value can significantly exceed the limit of 10. pH values higher than 11 can set in, which even damage rubber seals. The VDI 2035, Part I guidelines are fulfilled, however, VDI 2035, Part 2 suggests a pH value between 8.2 and maximum 10.

If aluminium materials are used, which is the case in many modern heating systems, a pH value of 8.5 must not be exceeded, because otherwise there is a threat of corrosion – and aluminium is attacked without the presence of oxygen. Therefore, apart from softening the heating fill and additional water, the heating water

should also be appropriately conditioned. This is the only way to comply with the VDI 2035 requirements and the recommendations and installation instructions of the heat pump manufacturer.

Part 2 of VDI 2035 also points out the reduction in total salt content (conductivity). The risk of corrosion is far lower if deionised water is used than is the case if the system is operated with salty, i.e. softened water.

Even if the water has been softened beforehand, it contains dissolved, corrosion-promoting salts, which act as electrolytes due to the use of different materials in the heating system and therefore accelerate corrosion processes. This can ultimately result in pitting.

ON THE SAFE SIDE WITH LOW-SALT OPERATION

The problems listed above do not occur at all with low-salt operation, as neither corrosive salts such as sulphates, chlorides and nitrates nor alkalising sodium hydrogen carbonate are in the heating water. The corrosive properties of deionised water are very low and in addition, fur cannot form in the boiler. This is the ideal approach for closed heating circuits, in particular, because low oxygen input into the heating circuit can also be tolerated.

In general, when the system is filled with deionised water, the pH value sets itself within the ideal range due to „self-alkalinisation“. If necessary, a pH value of 8.2 can be very easily alkalisied by adding chemicals. In this way, optimum protection of the entire heating system is achieved.

MONITORING

Analytical recording and monitoring of the relevant water values and the added active conditioning substances is of decisive importance. Therefore, they should be monitored regularly using appropriate water test equipment.

! ATTENTION

Before flushing and filling the heating circuit, the drain pipe of the safety valve must be connected.

- ① Flush heating circuit system thoroughly.
- ② Fill heating circuit...
- ③ Bleed heating circuit.



Insulating the hydraulic connections



NOTE.

Insulate the heating circuit and the heat source according to relevant local standards and guidelines.

- ① Check all hydraulic connections for leaks. Perform leak test...
- ② Insulate all connections, vibration isolation, connections and pipes of the heating circuit and the heat source. Insulate the heat source so that it is **vapour-diffusion tight**.

Commissioning

- ① Thoroughly check the installation and work through the items on the general checklist...



“General checklist”.

The installation inspection will prevent damage to the heat pump system that could be caused by improperly executed work.

Ensure that...

- the **clockwise rotary field** of the load power supply (compressor) is ensured.
- The heat pump **installation and assembly** is according to the requirements in this operating manual.
- The electrical installation work has been carried out properly.
- The power supply for the heat pump must be equipped with a three-phase automatic circuit-breaker with at least 3 mm contact spacing to IEC 60947-2. Note the level of the tripping current.
- The heating circuit and the heat source are flushed, filled and bled thoroughly.
- All valves and shut-off devices of the heating circuit are open.
- All valves and shut-off devices of the heat source are open.
- All pipe systems and components of the system are sealed.

- ② Carefully fill out and sign the completion report for heat pump systems...
- ④ The heat pump system will be commissioned by customer service personnel authorized by the manufacturer. There is a fee for commissioning!

Dismantling



DANGER!

Risk of fatal injury due to electric shock!
Electrical connections may be installed only by qualified electricians.
Before opening the unit, disconnect the system from the power supply and prevent it from being switched back on!



WARNING!

Only qualified heating or cooling system personnel are allowed to remove the unit from the system and dismantle the unit.



ATTENTION

The anti-freeze mixture of the heat source must not be allowed to enter the sewer system. Collect anti-freeze mixture and dispose of properly.



ATTENTION

Recycle or ensure proper disposal of unit components, refrigerants and oil according to the relevant regulations, standards and guidelines.

REMOVAL OF THE BUFFER BATTERY



ATTENTION

Before scrapping the heating and heat pump regulator, remove the buffer battery on the processor board. The battery can be pushed out using a screwdriver. Dispose of battery and electronic components in an environmentally friendly way.



Technical data / scope of delivery

Heat pump type	Brine/Water Air/Water Water/Water	• relevant — not relevant
Installation location	Indoors Outdoors	• relevant — not relevant
Conformity		CE
Power data	Heating power/COP at	
	B0/W35 Standard point as per EN14511	2 Compressors 1 Compressor
		kW ... kW ...
	B0/W45 Standard point as per EN14511	2 Compressors 1 Compressor
		kW ... kW ...
	B7/W35 Standard point as per EN14511	2 Compressors 1 Compressor
		kW ... kW ...
	B0/W50 Standard point as per EN14511	2 Compressors 1 Compressor
		kW ... kW ...
Operating limits	Heat circuit	°C
	Heat source	°C
	Additional operating points	...
Noise	Sound pressure level at 1m gap around the machine averaged (in free field)	dB(A)
	Sound power level as per EN12102	dB
Heat source	Volumetric flow: minimum throughput nominal throughput maximum throughput	l/h
	Pressure loss in heat pump Δp Volumetric flow	bar l/h
	Recommended brine circulating pump	...
	Total compression of the recommended pump at nominal brine volumetric flow	bar l/h
	Antifreeze	Monoethylene glycol
	Minimum concentration frostproof to	% °C
Heat circuit	Volumetric flow: minimum throughput nominal throughput maximum throughput	l/h
	Pressure loss in heat pump Δp Volumetric flow	bar l/h
	Free compression of heat pump Δp Volumetric flow	bar l/h
	Temperature spread for B0/W35	K
General device data	Earth (see dimensional diagram for the size indicated)	Size
	Total weight	kg
	Extra weight of construction unit 1	kg
	Extra weight of construction unit 2	kg
	Connections	Heat circuit Heat source
	Refrigerant	Refrigerant type Filling capacity
Electrics	Voltage code All-pole circuit breaker for pump *)	... A
	Voltage code Control voltage circuit breaker *)	... A
	Voltage code Electrical heating element circuit breaker *)	A
Heat pump	Effect power consumption in the normal point B0/W35 as per EN255: Power consumption. Current consumption $\cos\phi$	kW A ...
	Maximum machine current within the operating limits	A
	Starting current: direct with slow-starter	A A
	Protection type	IP
	Power of electrical heating element 3 2 1-phase	kW kW kW
Components	Circulating pump for heat circuit at nominal throughput: Power consumption Current consumption	kW A
	Circulating pump for heat source at nominal throughput: Power consumption Current consumption	kW A
	Setting range for motor protection switch of heat source circulating pump	A
Passive cooling function	Data only for devices with ID K: Cooling power at nominal volumetric flow rates (15 °C heat source, 25 °C hot water)	kW
Safety devices	Safety assembly for heat circuit Safety assembly for heat source	in scope of supply: • yes — no
Heating and heat pump control		in scope of supply: • yes — no
Electronic soft-starter		integrated: • yes — no
Expansion vessels	Heat source: Scope of supply Volume Supply pressure	• yes — no l bar
	Heat circuit: Scope of supply Volume Supply pressure	• yes — no l bar
Overflow valve		integrated: • yes — no
Vibration isolation	Heat circuit Heat source	in scope of supply: • yes — no



	AP-BW30-37	AP-BW30-45	AP-BW30-58	AP-BW30-69	AP-BW30-29H	AP-BW30-56H
	• — —	• — —	• — —	• — —	• — —	• — —
	• —	• —	• —	• —	• —	• —
	•	•	•	•	•	•
	—	—	—	—	—	—
	37,2 4,80	45,0 4,80	57,6 4,80	68,5 4,60	27,5 4,30	53,8 4,50
	35,8 3,70	42,7 3,70	55,8 3,80	66,1 3,60	26,7 3,40	52,9 3,80
	45,4 5,60	55,0 5,70	71,1 5,80	84,1 5,40	33,2 5,10	65,9 5,20
	34,8 2,90	41,1 2,90	54,1 3,00	64,6 2,90	25,9 2,70	52,1 3,10
	20 - 57	20 - 58	20 - 60	20 - 60	20 - 64	20 - 64
	-5 - 25	-5 - 25	-5 - 25	-5 - 25	-5 - 25	-5 - 25
	B3/W65	B0/W65	B0/W65	B0/W65	B4/W70	B0/W70
	39	41	42	44	43	44
	54	56	57	59	58	59
	6900 9200 11100	8100 10800 13000	10200 13600 16300	13000 17300 21000	4900 6500 7800	9400 12600 19100
	0,16 9200	0,15 10800	0,15 13600	0,16 17300	0,16 6500	0,16 12600
	—	—	—	—	—	—
	—	—	—	—	—	—
	•	•	•	•	•	•
	25 -13	25 -13	25 -13	25 -13	25 -13	25 -13
	3200 6400 8000	3900 7800 9400	4900 9700 12200	5700 11300 14200	2400 4700 5900	4400 8900 11200
	0,12 6400	0,12 7800	0,12 9700	0,12 11300	0,12 4700	0,12 8900
	— —	— —	— —	— —	— —	— —
	5,0	5,0	5,1	5,2	5,0	5,0
	1	1	1	1	1	1
	371	385	441	484	319	521
	—	—	—	—	—	—
	—	—	—	—	—	—
	DN50 DIN2566	DN50 DIN2566	DN50 DIN2566	DN50 DIN2566	DN50 DIN2566	DN50 DIN2566
	DN50 DIN2566	DN50 DIN2566	DN50 DIN2566	DN50 DIN2566	DN50 DIN2566	DN50 DIN2566
	R410A 7,2	R410A 8,2	R410A 11,2	R410A 13,4	R134a 6,7	R134a 12,8
	3~/PE/400V/50Hz C32	3~/PE/400V/50Hz C40	3~/PE/400V/50Hz C50	3~/PE/400V/50Hz C50	3~/PE/400V/50Hz C40	3~/PE/400V/50Hz C50
	1~/N/PE/230V/50Hz B16	1~/N/PE/230V/50Hz B16	1~/N/PE/230V/50Hz B16	1~/N/PE/230V/50Hz B16	1~/N/PE/230V/50Hz B16	1~/N/PE/230V/50Hz B16
	— —	— —	— —	— —	— —	— —
	7,8 13,97 0,8	9,4 18,28 0,72	12,0 22,16 0,76	14,9 28,14 0,75	6,4 14,92 0,62	12,0 27,80 0,63
	31	34	40	48,5	34	45,6
	140 85	174 88	225 110	272 110	174 100	310 120
	20	20	20	20	20	20
	— — —	— — —	— — —	— — —	— — —	— — —
	— —	— —	— —	— —	— —	— —
	— —	— —	— —	— —	— —	— —
	—	—	—	—	—	—
	—	—	—	—	—	—
	— —	— —	— —	— —	— —	— —
	•	•	•	•	•	•
	•	•	•	•	•	•
	— —	— —	— —	— —	— —	— —
	— —	— —	— —	— —	— —	— —
	—	—	—	—	—	—
	—	—	—	—	—	—
	813428a	813429a	813430a	813431a	813432a	813433



AP-BW30-37

Performance curves

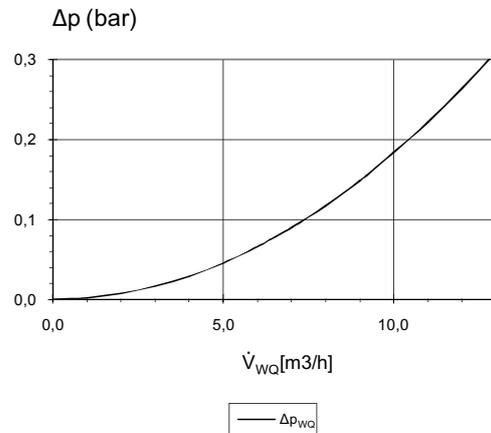
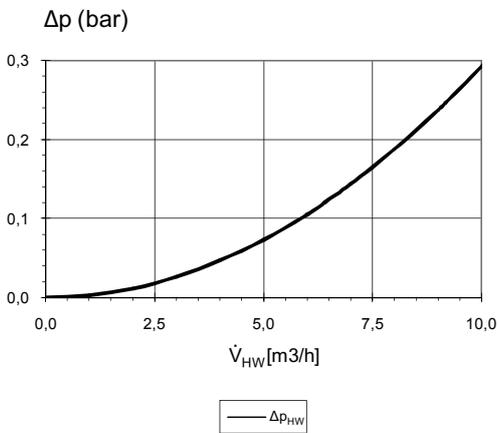
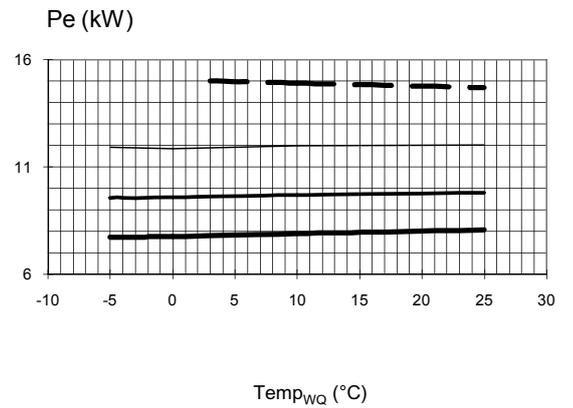
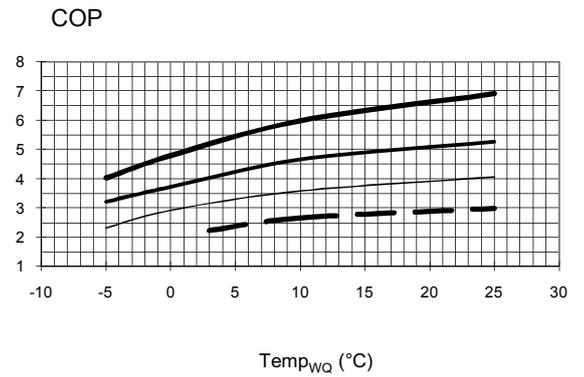
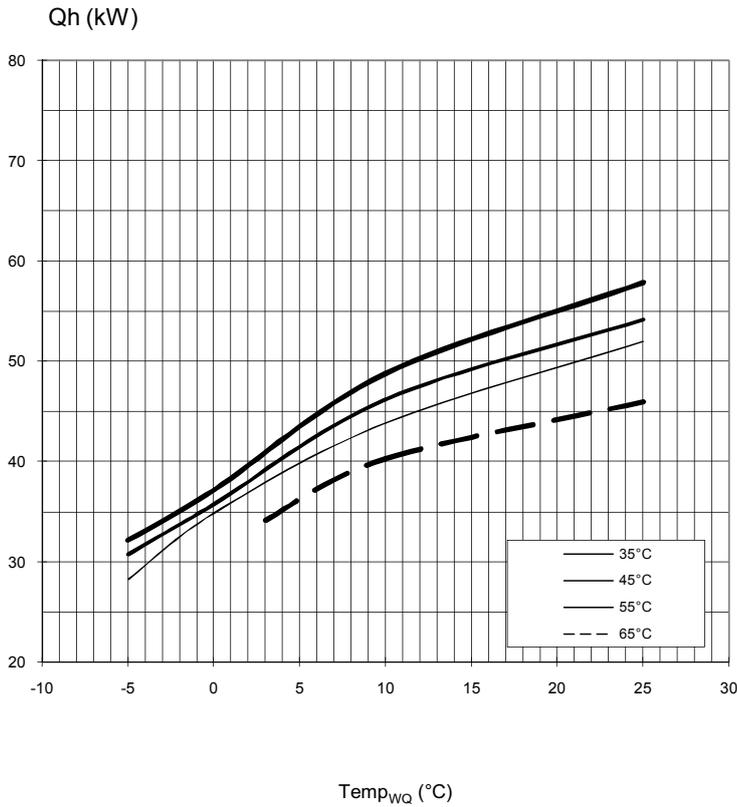

823077a

Legend:	UK823025L
\dot{V}_{HW}	Volume flow, heating water
\dot{V}_{WQ}	Volume flow, heat source
$Temp_{WQ}$	Temperature, heat source
Q_h	Heating capacity
Pe	Power consumption
COP	Coefficient of performance / efficiency rating
Δp_{HW}	Pressure loss heat circuit
Δp_{WQ}	Pressure loss heat source
VD	Compressor(s)



Performance curves

AP-BW30-45

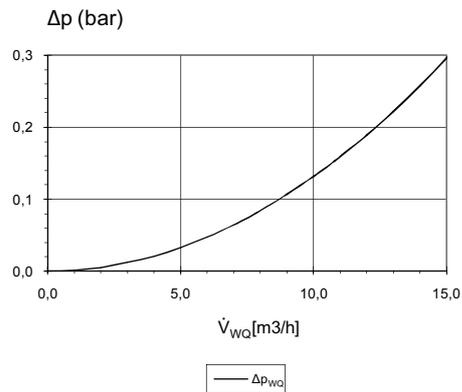
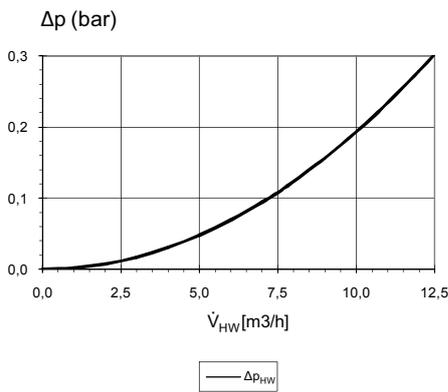
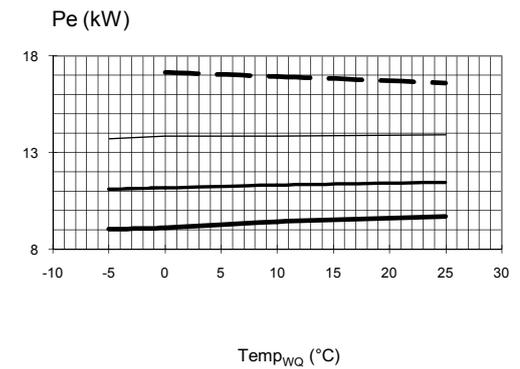
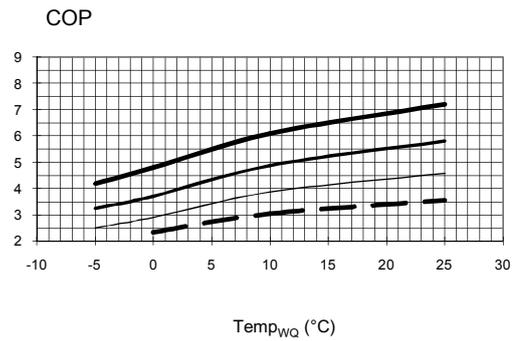
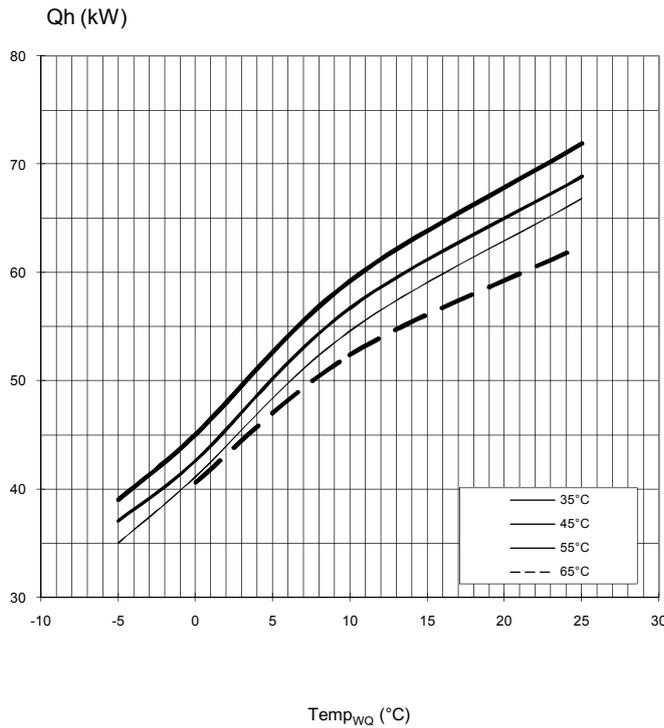

823078a

Legend:	UK823025L
\dot{V}_{HW}	Volume flow, heating water
\dot{V}_{wQ}	Volume flow, heat source
Temp _{wQ}	Temperature, heat source
Qh	Heating capacity
Pe	Power consumption
COP	Coefficient of performance / efficiency rating
Δp _{HW}	Pressure loss heat circuit
Δp _{wQ}	Pressure loss heat source
VD	Compressor(s)



AP-BW30-58

Performance curves

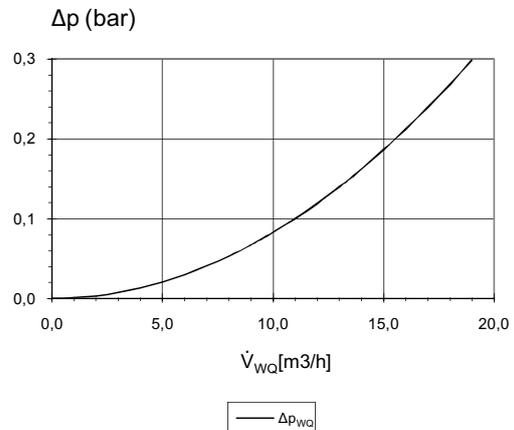
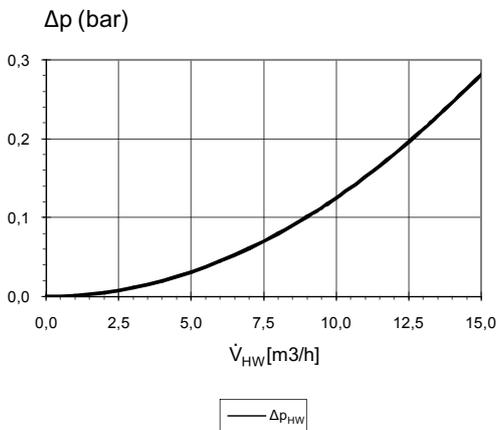
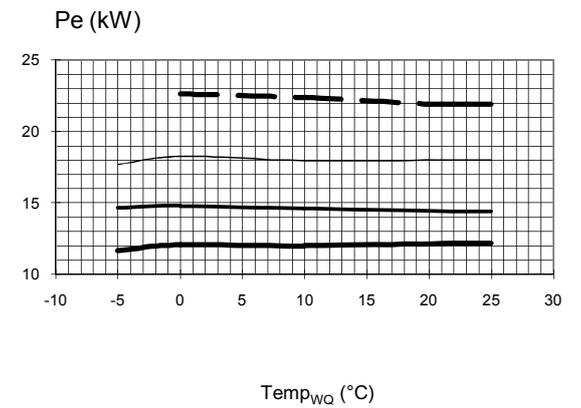
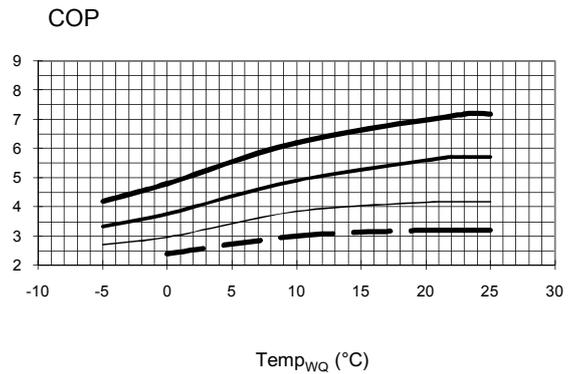
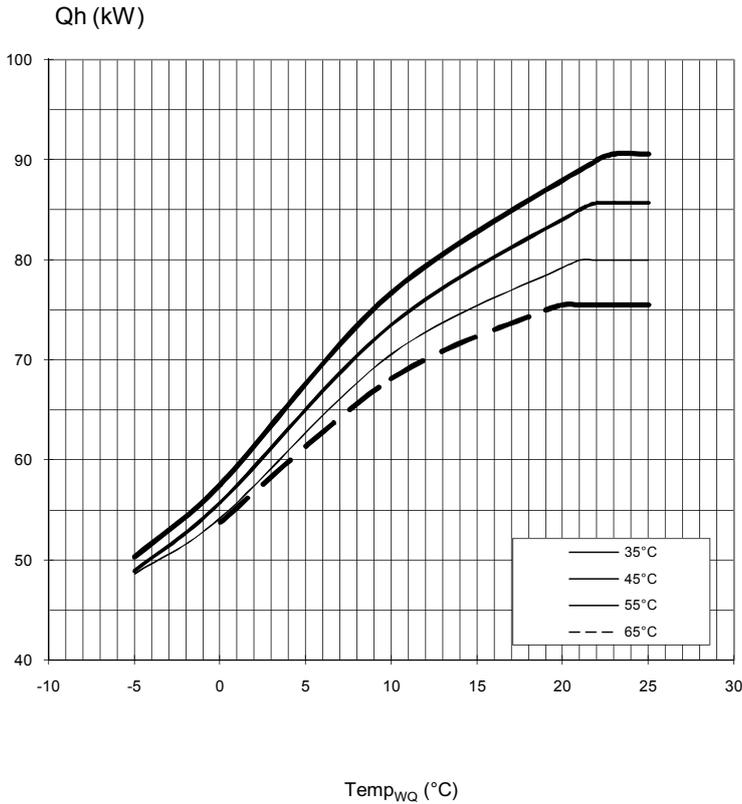

823079a

Legend:	UK823025L
\dot{V}_{HW}	Volume flow, heating water
\dot{V}_{WQ}	Volume flow, heat source
$Temp_{WQ}$	Temperature, heat source
Q_h	Heating capacity
Pe	Power consumption
COP	Coefficient of performance / efficiency rating
Δp_{HW}	Pressure loss heat circuit
Δp_{WQ}	Pressure loss heat source
VD	Compressor(s)



Performance curves

AP-BW30-69

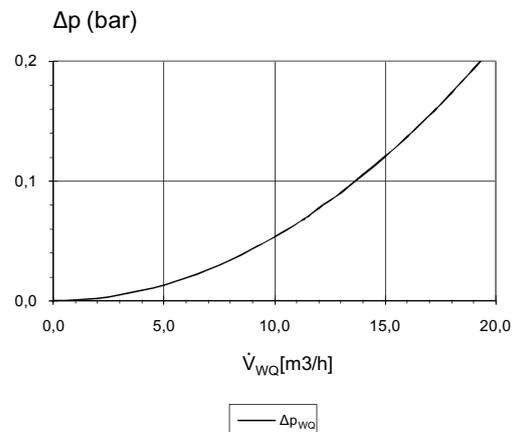
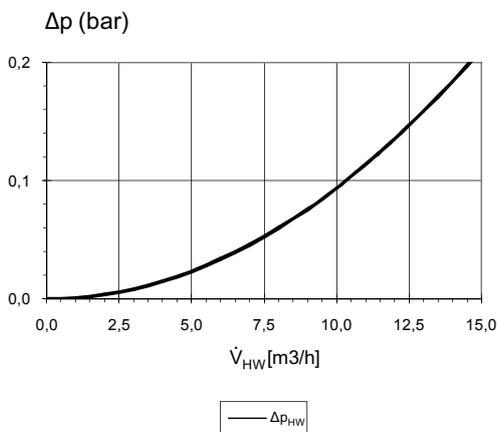
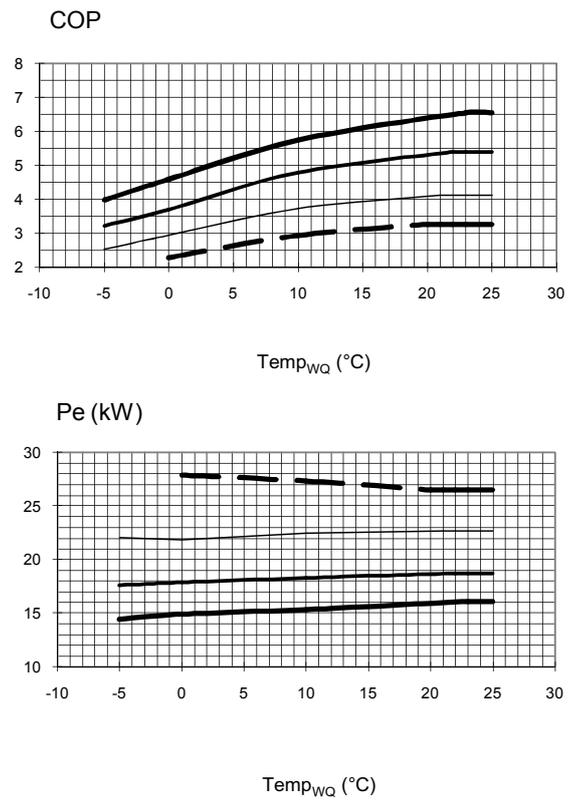
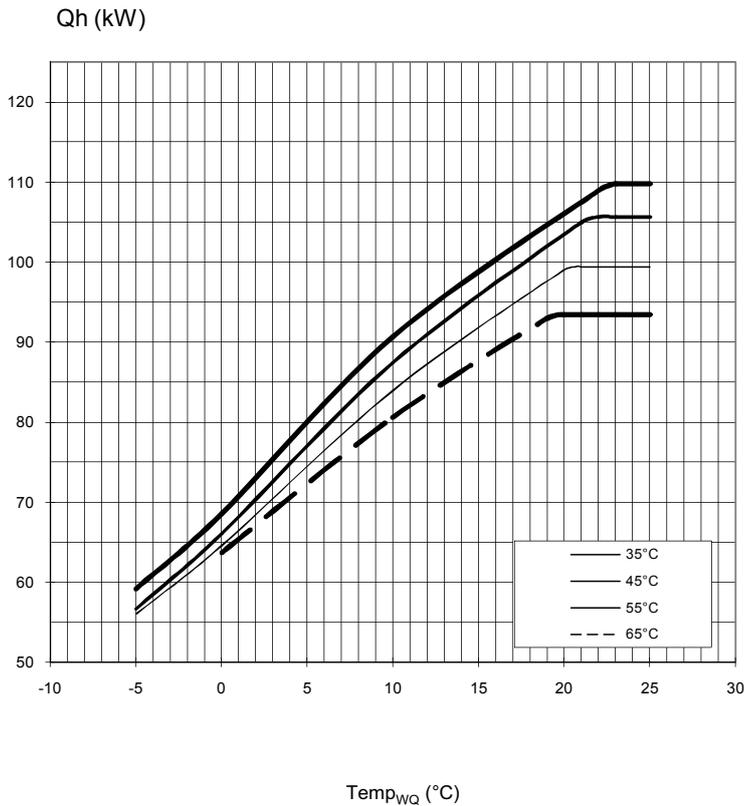

823080a

Legend:	UK823025L
\dot{V}_{HW}	Volume flow, heating water
\dot{V}_{wQ}	Volume flow, heat source
Temp _{wQ}	Temperature, heat source
Qh	Heating capacity
Pe	Power consumption
COP	Coefficient of performance / efficiency rating
Δp _{HW}	Pressure loss heat circuit
Δp _{wQ}	Pressure loss heat source
VD	Compressor(s)



AP-BW30-29H

Performance curves

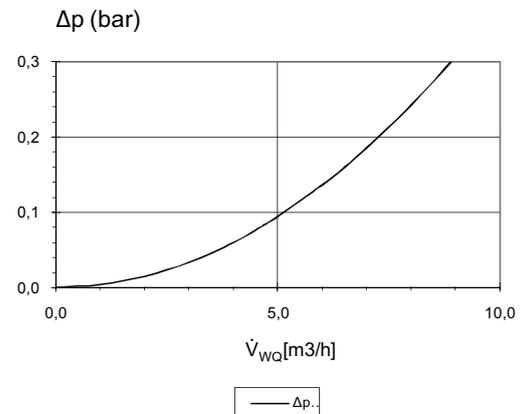
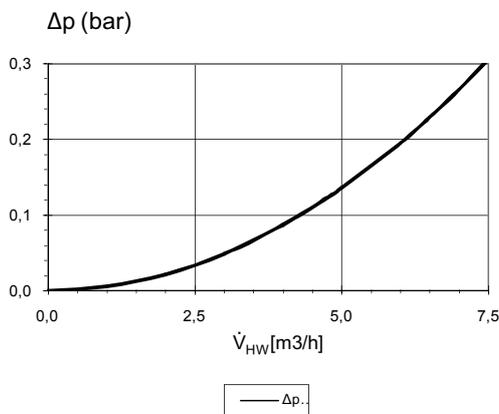
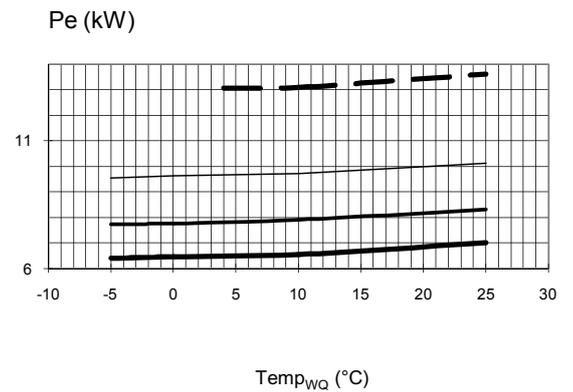
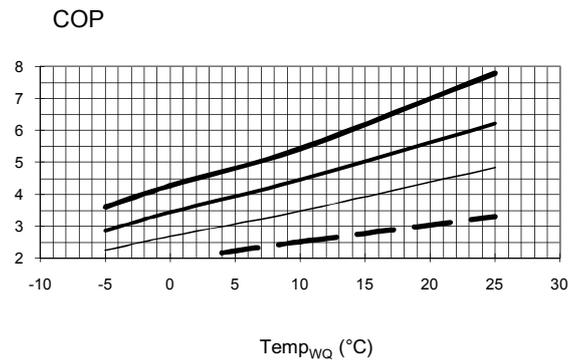
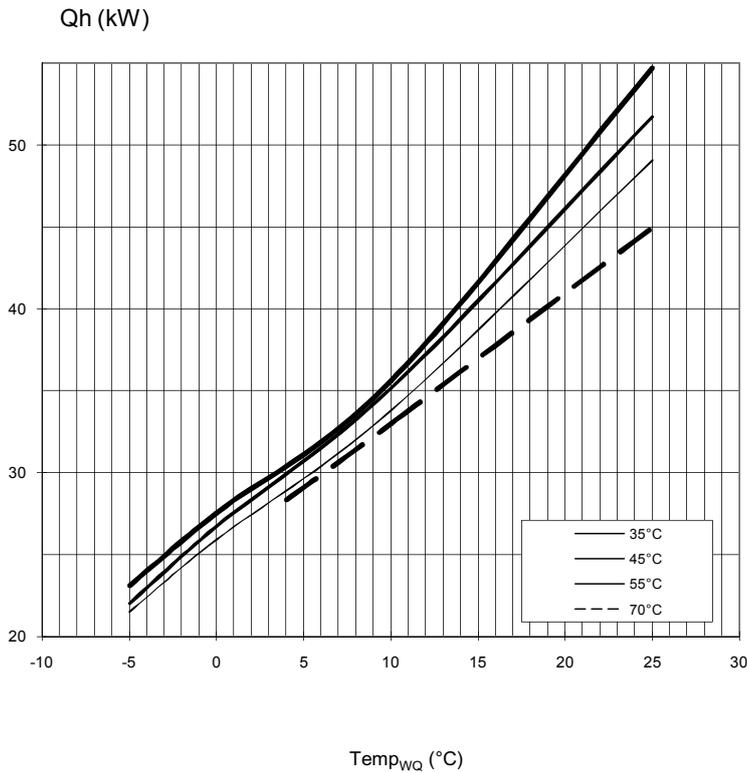

823081

Legend:	UK823025L
\dot{V}_{HW}	Volume flow, heating water
\dot{V}_{WQ}	Volume flow, heat source
Temp _{WQ}	Temperature, heat source
Qh	Heating capacity
Pe	Power consumption
COP	Coefficient of performance / efficiency rating
Δp_{HW}	Pressure loss heat circuit
Δp_{WQ}	Pressure loss heat source
VD	Compressor(s)



Performance curves

AP-BW30-56H

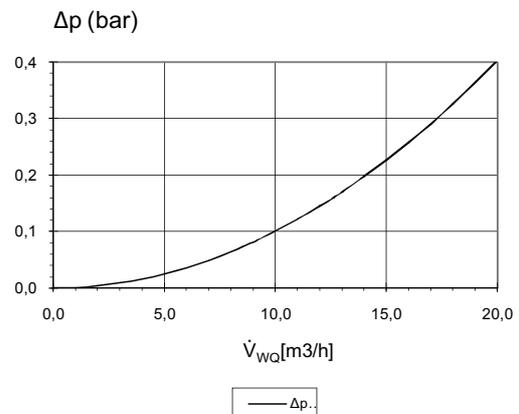
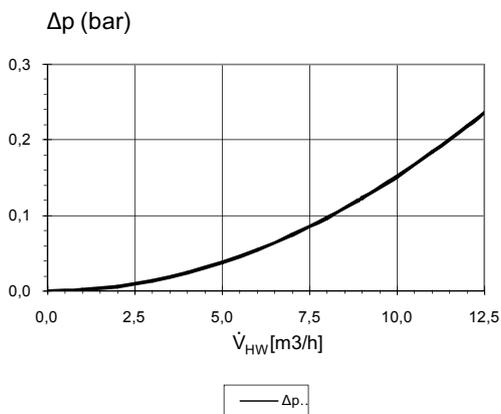
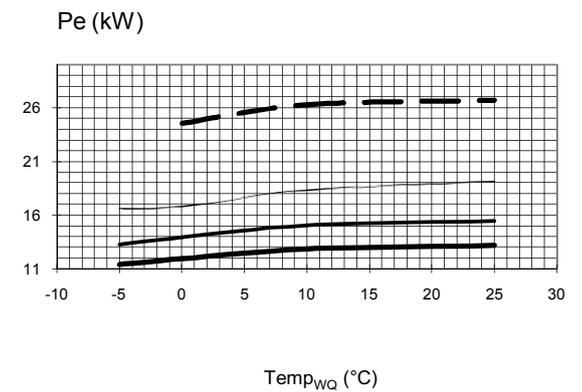
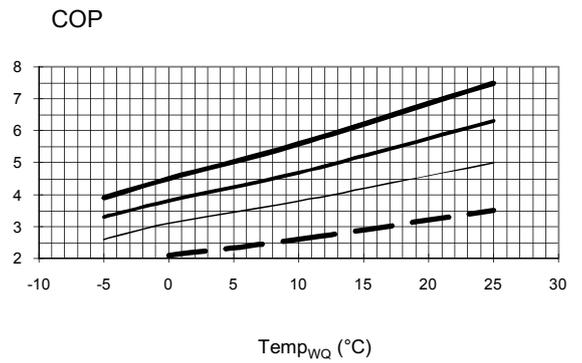
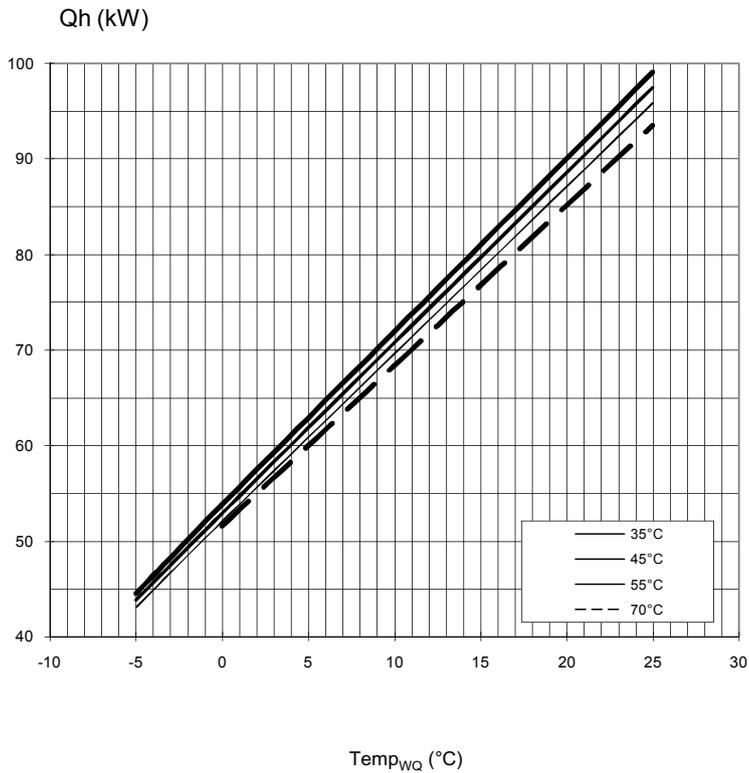

823082

Legend:	UK823025L
\dot{V}_{HW}	Volume flow, heating water
\dot{V}_{wQ}	Volume flow, heat source
Temp _{wQ}	Temperature, heat source
Qh	Heating capacity
Pe	Power consumption
COP	Coefficient of performance / efficiency rating
Δp _{HW}	Pressure loss heat circuit
Δp _{wQ}	Pressure loss heat source
VD	Compressor(s)

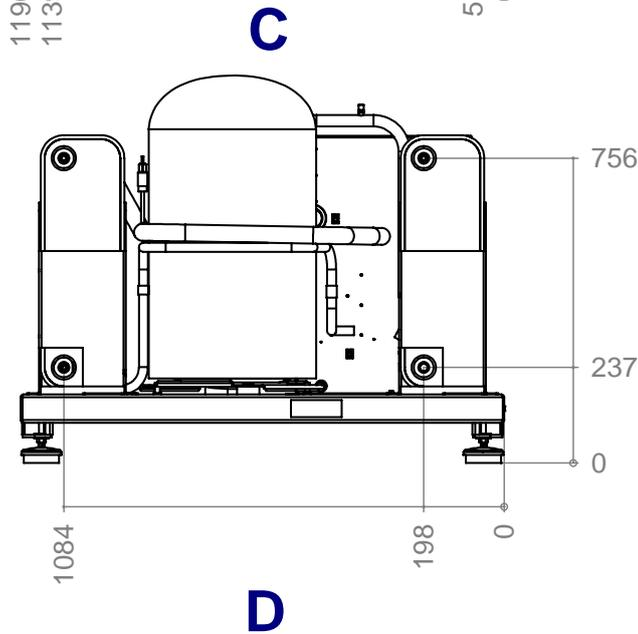
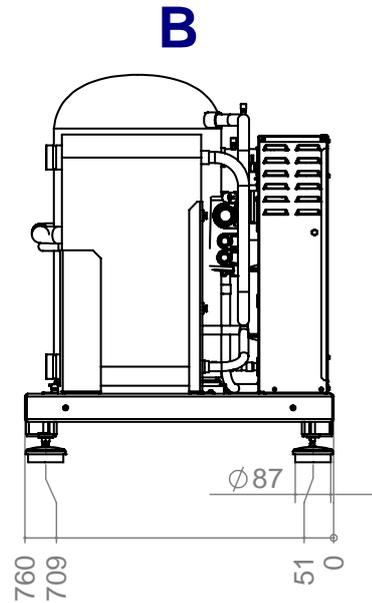
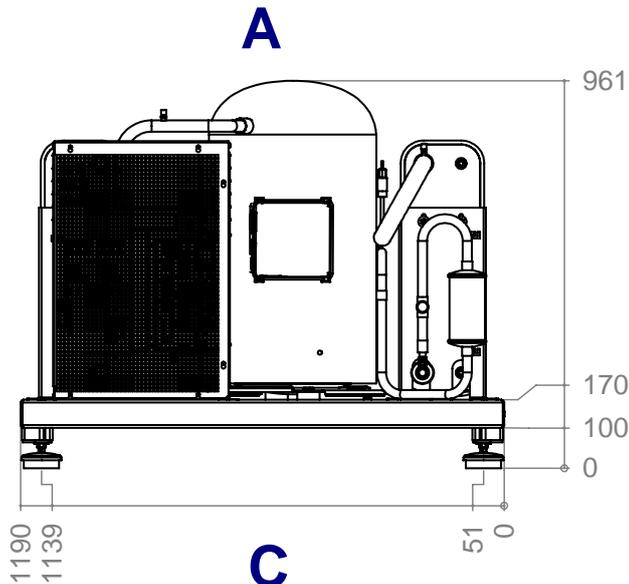

- Legend: EN819407
All dimensions in mm.
- A Front view
 - B Side view from left
 - C Rear view
 - D Front view with facing
 - E View from underneath with facing

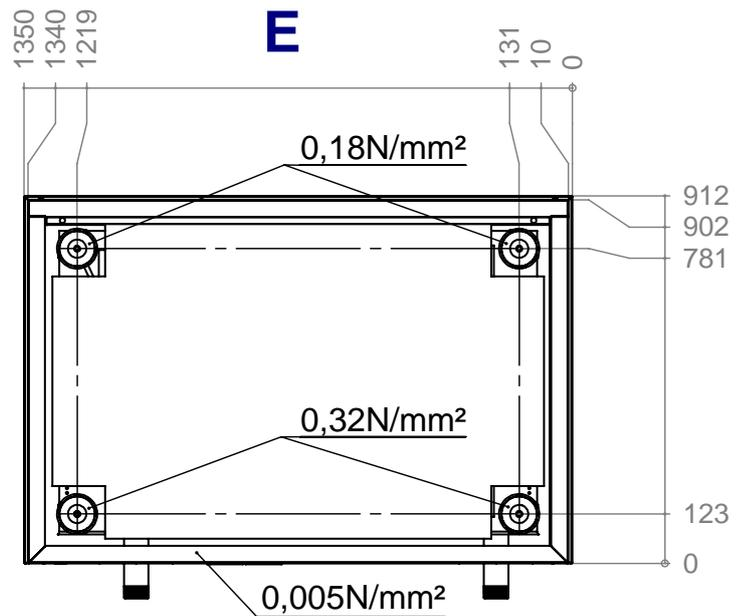
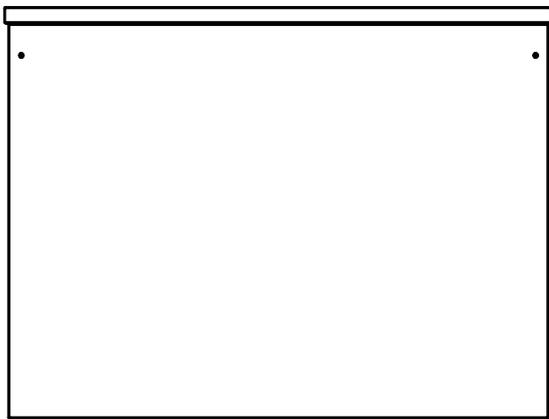



Dimensional drawings with housing

AP-BW30-37 to AP-BW30-69

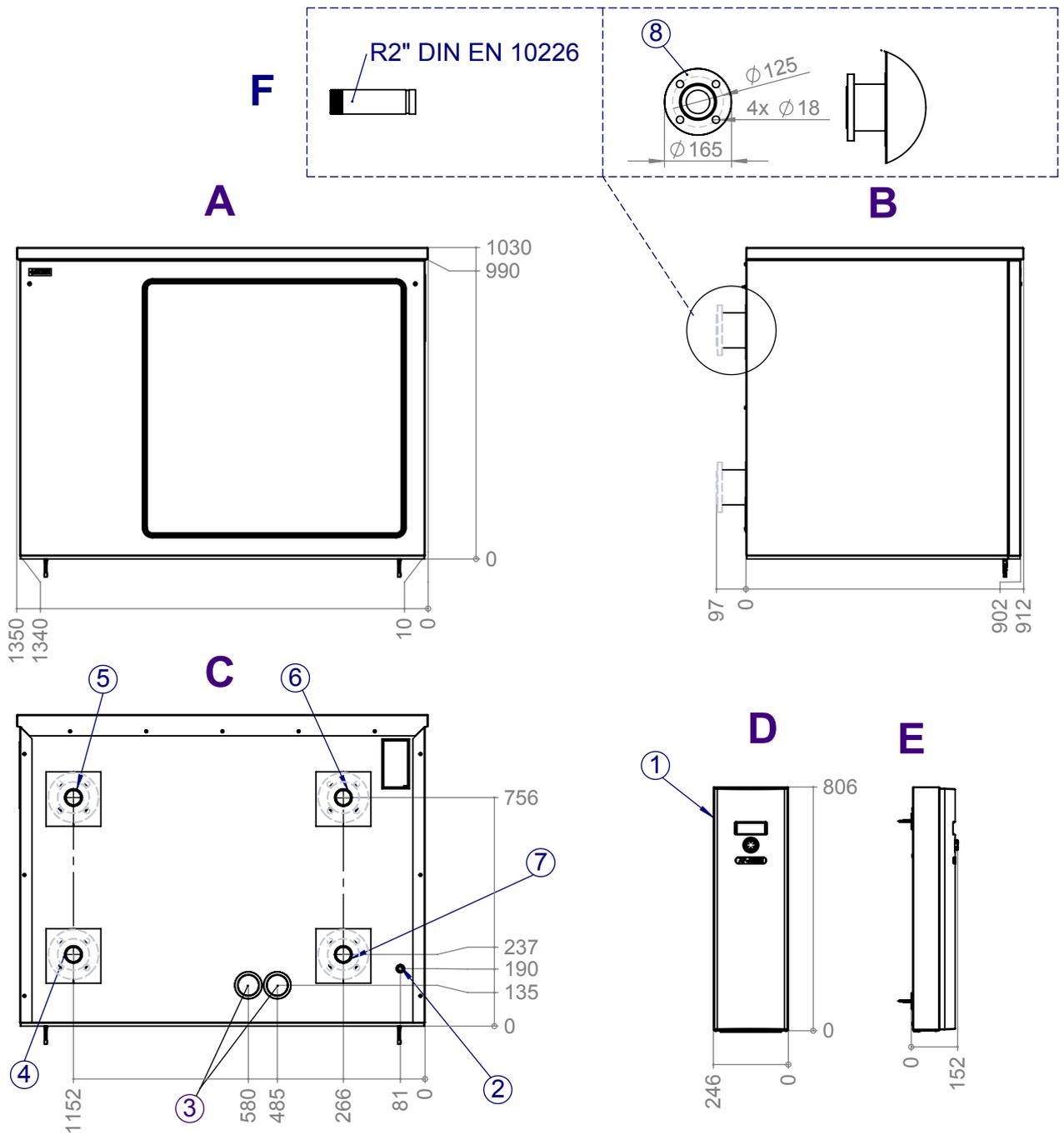

Legend:	UK819428	Item	Designation
		1	Control element (for wall-mounting)
A	Front view	2	Penetration for connection and LIN bus cable
B	Side view from left	3	Penetration for electric cable
C	Rear view	4	Heat source outlet
D	Front view, control element	5	Heat source inlet
E	Side view from left, control element	6	Heating water outlet (flow)
F	Connection options	7	Heating water inlet (return)
		8	Flange DN50 PN10/16 DIN2566



AP-BW30-29H to AP-BW30-56H

Dimensional drawings - moving dimensions

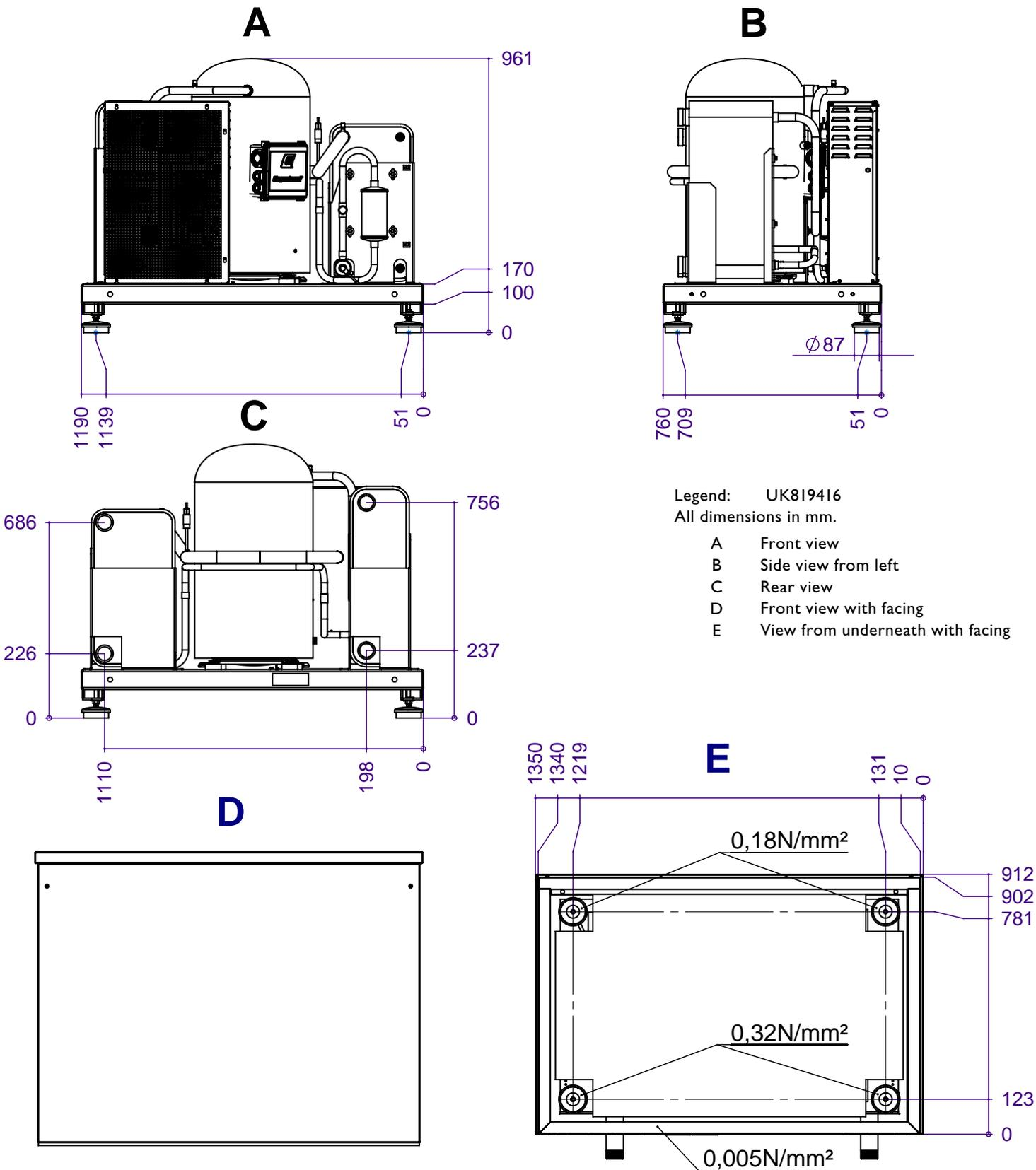



Dimensional drawings with housing

AP-BW30-29H to BW30-56H

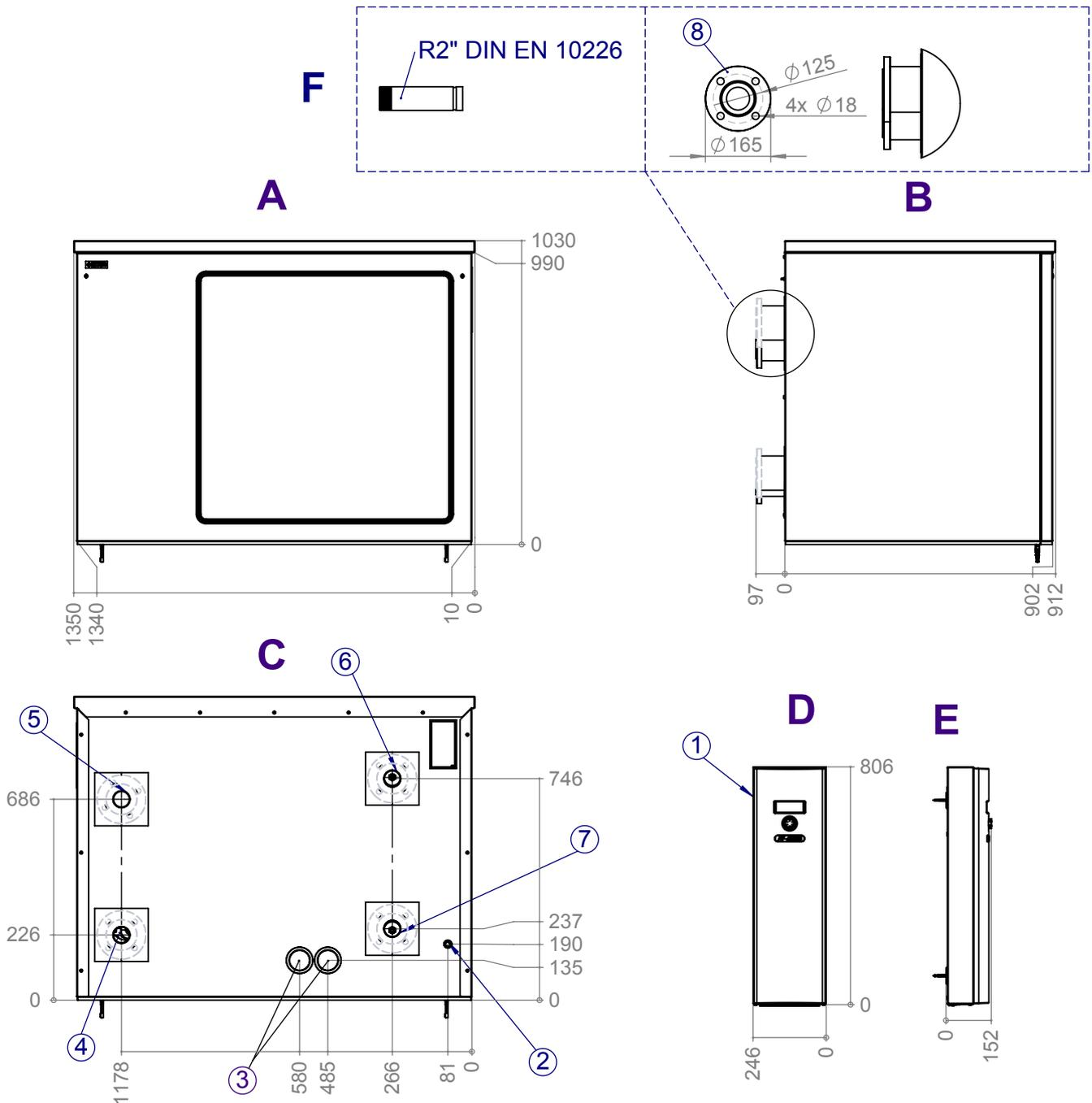

Legend:	UK819429	Item	Designation
		1	Control element (for wall-mounting)
A	Front view	2	Penetration for connection and LIN bus cable
B	Side view from left	3	Penetration for electric cable
C	Rear view	4	Heat source outlet
D	Front view, control element	5	Heat source inlet
E	Side view from left, control element	6	Heating water outlet (flow)
F	Connection options	7	Heating water inlet (return)
		8	Flange DN50 PN10/I6 DIN2566

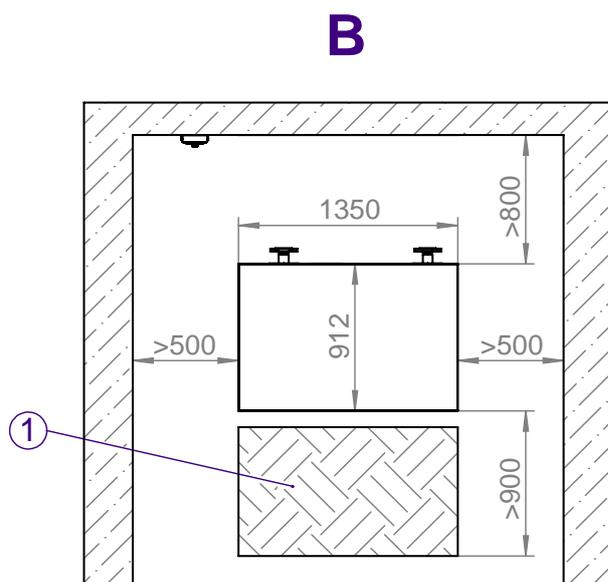
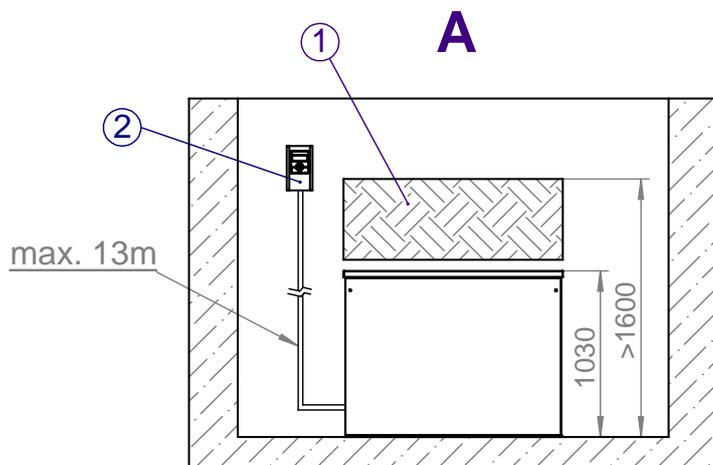

Legend:	EN819408
A	Front view
B	Plan view
1	Hatched area = space for service purposes
2	Control element



Installation plan

AP-BW30-37 to 69, AP-BW30-29H- to 56H

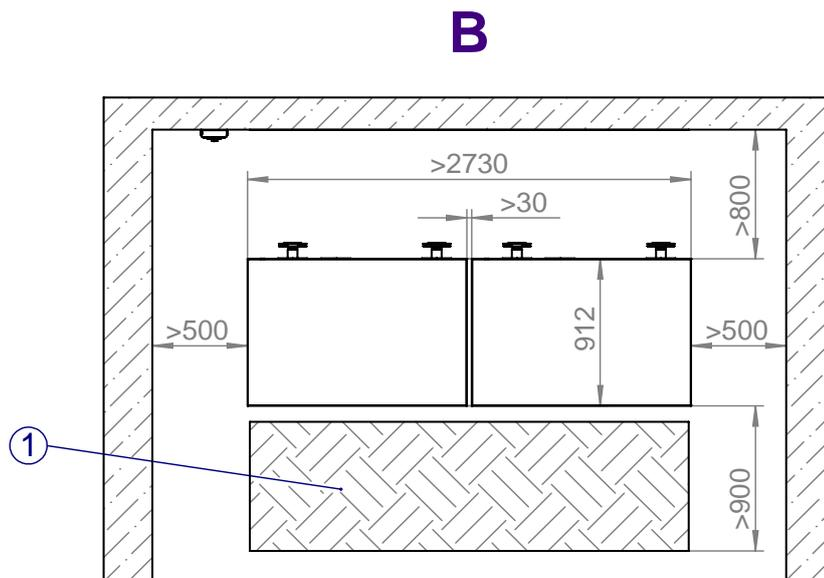
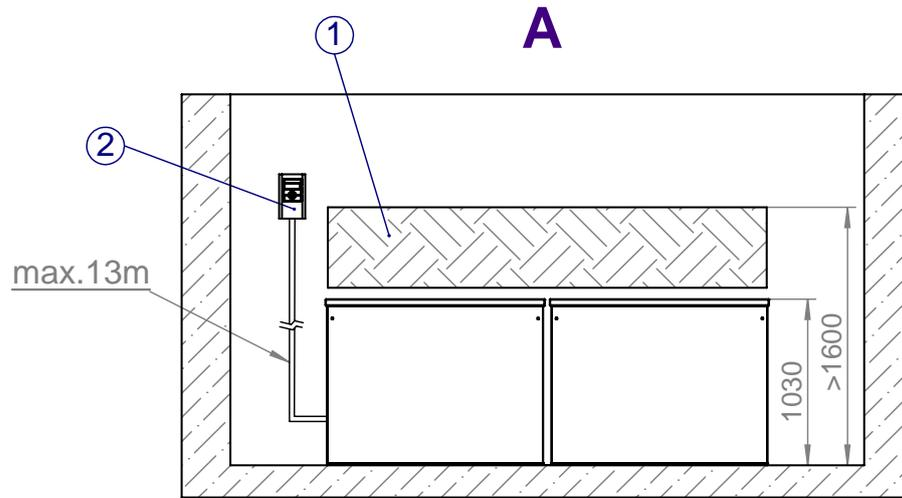

Legend:	EN819409
A	Front view
B	Plan view
1	Hatched area = space for service purposes
2	Control element



Terminal diagram

AP-BW30-37 to 69, AP-BW30-29H to 56H

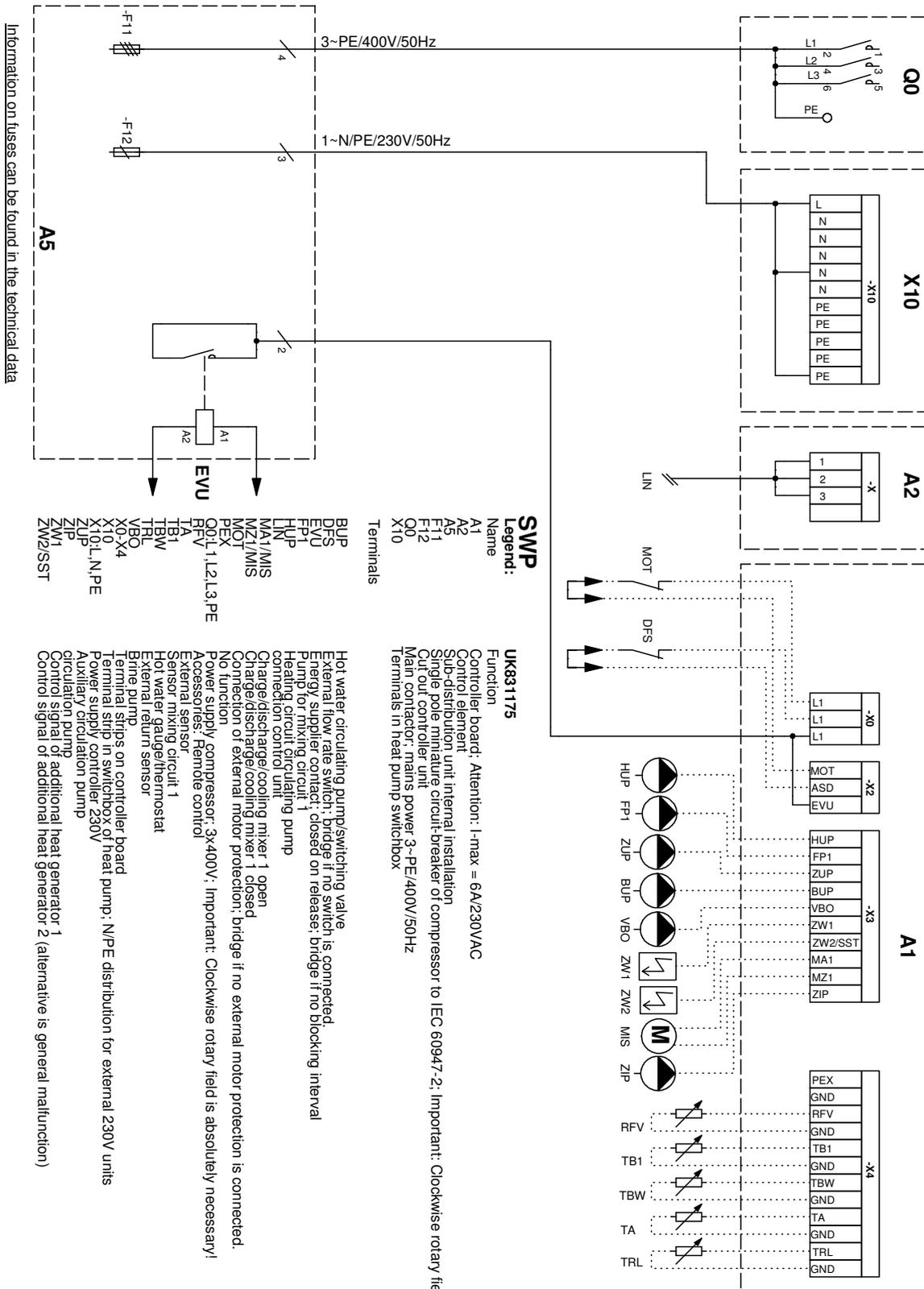



AP-BW30-37, AP-BW30-45

Circuit diagram 1/3

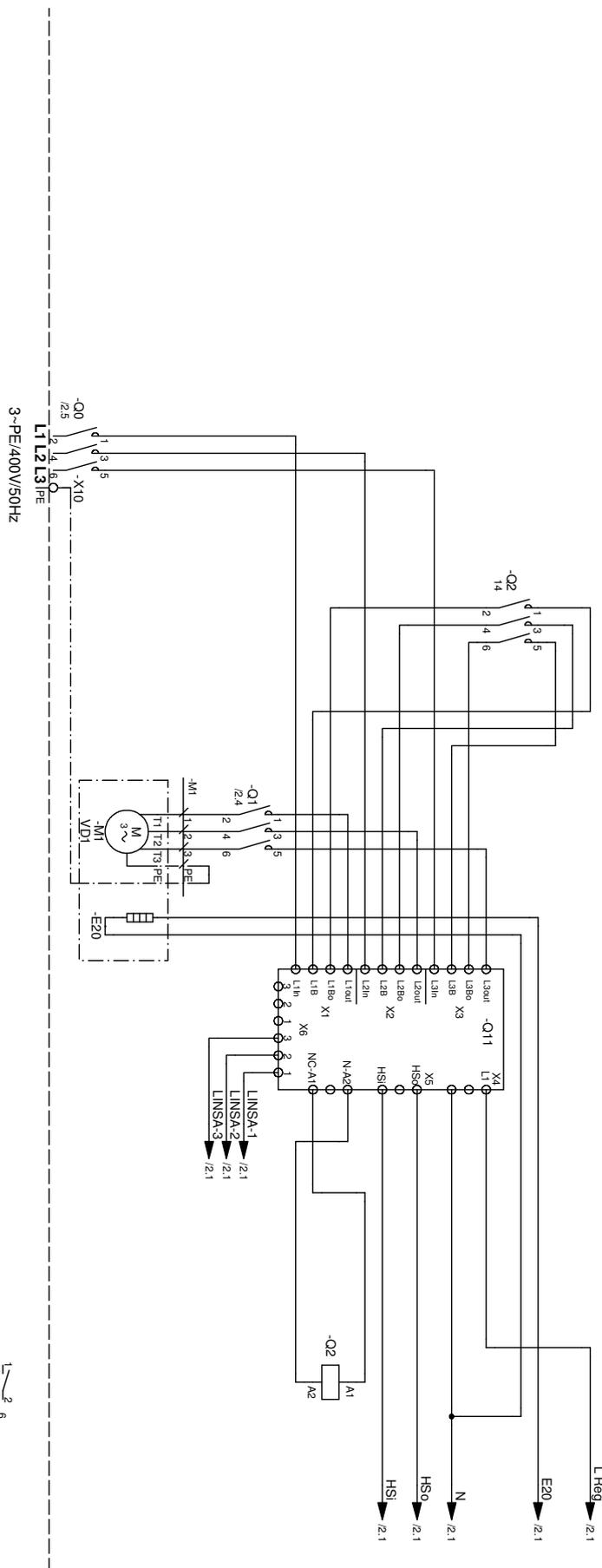

- Legend:**
- | | |
|---------------------|---|
| Operating materials | UK817379 |
| 3-PE/400V/50Hz | Function |
| E20 | L1, L2, L3, PE: power supply, output, compressor: clockwise rotary field is absolutely necessary! |
| M1 | Sump heating for compressor 1 |
| Q0 | compressor |
| Q1 | Main contactor, compressor |
| Q2 | Compressor heater |
| CT1 | Bypass contactor, soft starter |
| X10 | Starting current limit compressor |
| | Terminal in switch box heat pump |



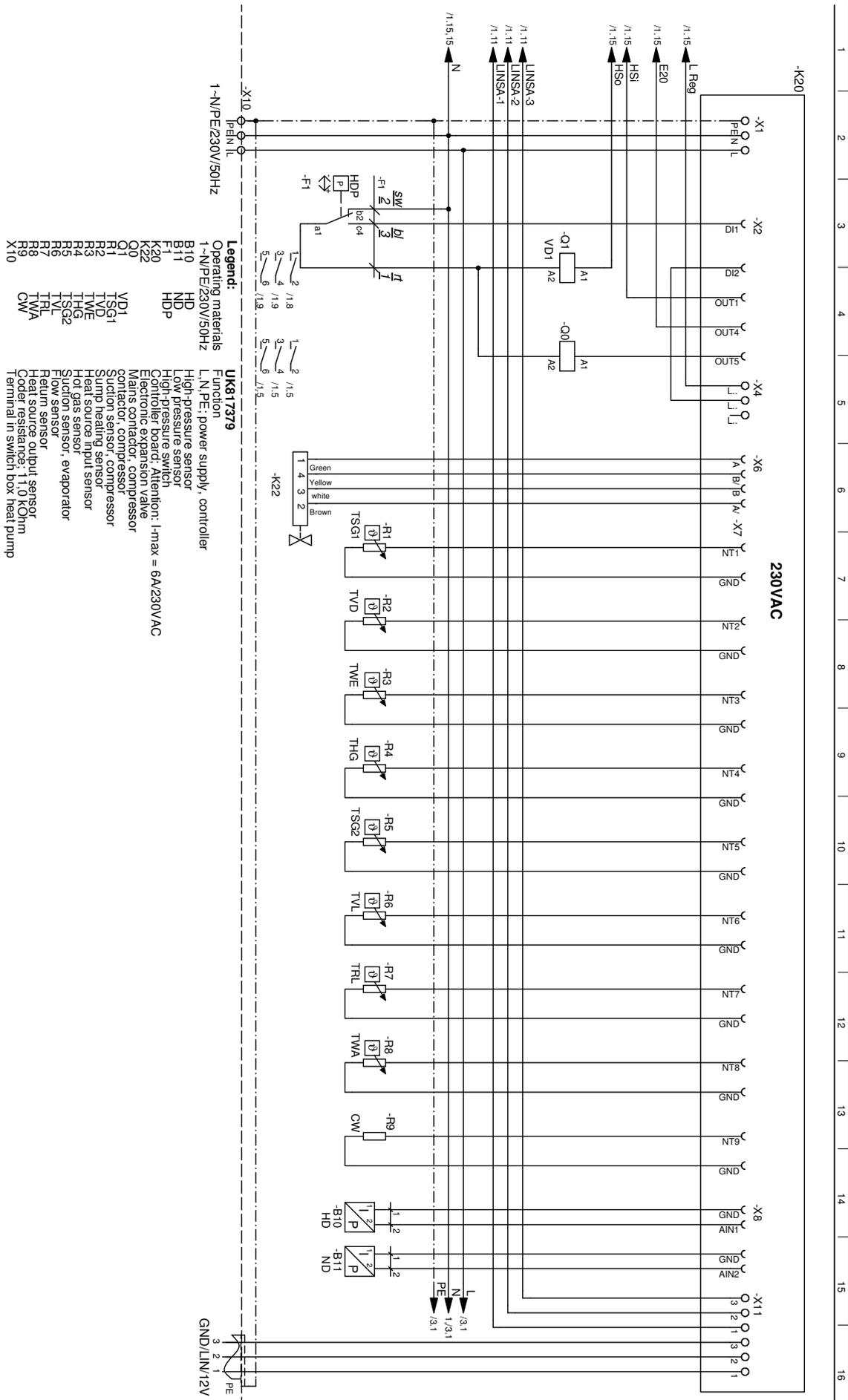



Circuit diagram 3/3

AP-BW30-37, AP-BW30-45

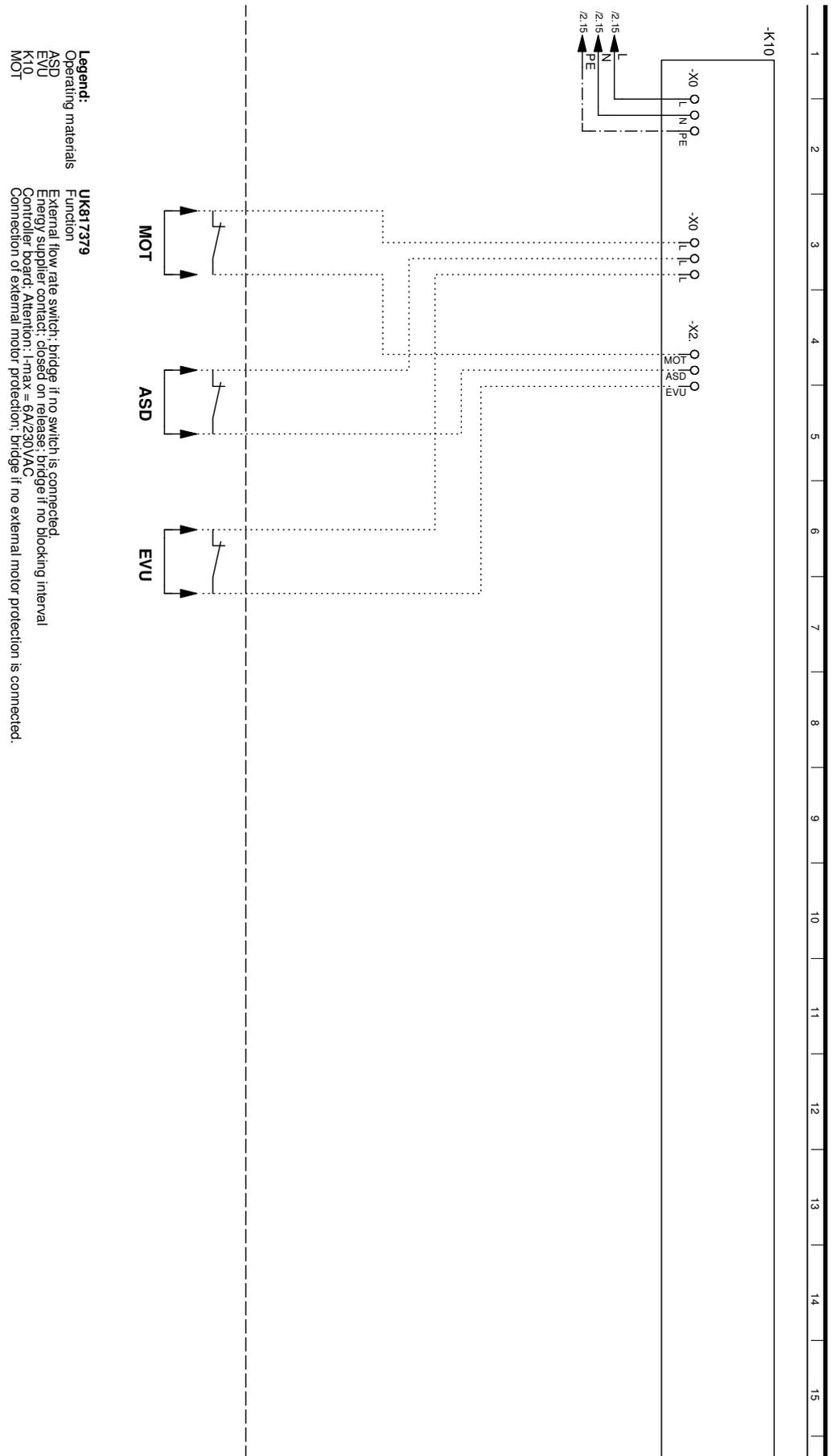



AP-BW30-58, AP-BW30-69, AP-BW30-56H

Circuit diagram 1/3

- Legend:**
- Operating materials
 - 3~PE/400V/50Hz
 - E20
 - F1.1
 - M1
 - Q0
 - Q2
 - Q1
 - X10
 - VD1
 - VD1
- UK817380**
- Function
 - L1,L2,L3,PE: power supply, output, compressor; clockwise rotary field is absolutely necessary!
 - Sump heating for compressor 1
 - Compressor motor protection
 - Compressor
 - Mains contactor, compressor
 - Contact, compressor
 - Contact, compressor starter
 - Starts current limit compressor
 - Terminal in switch box heat pump

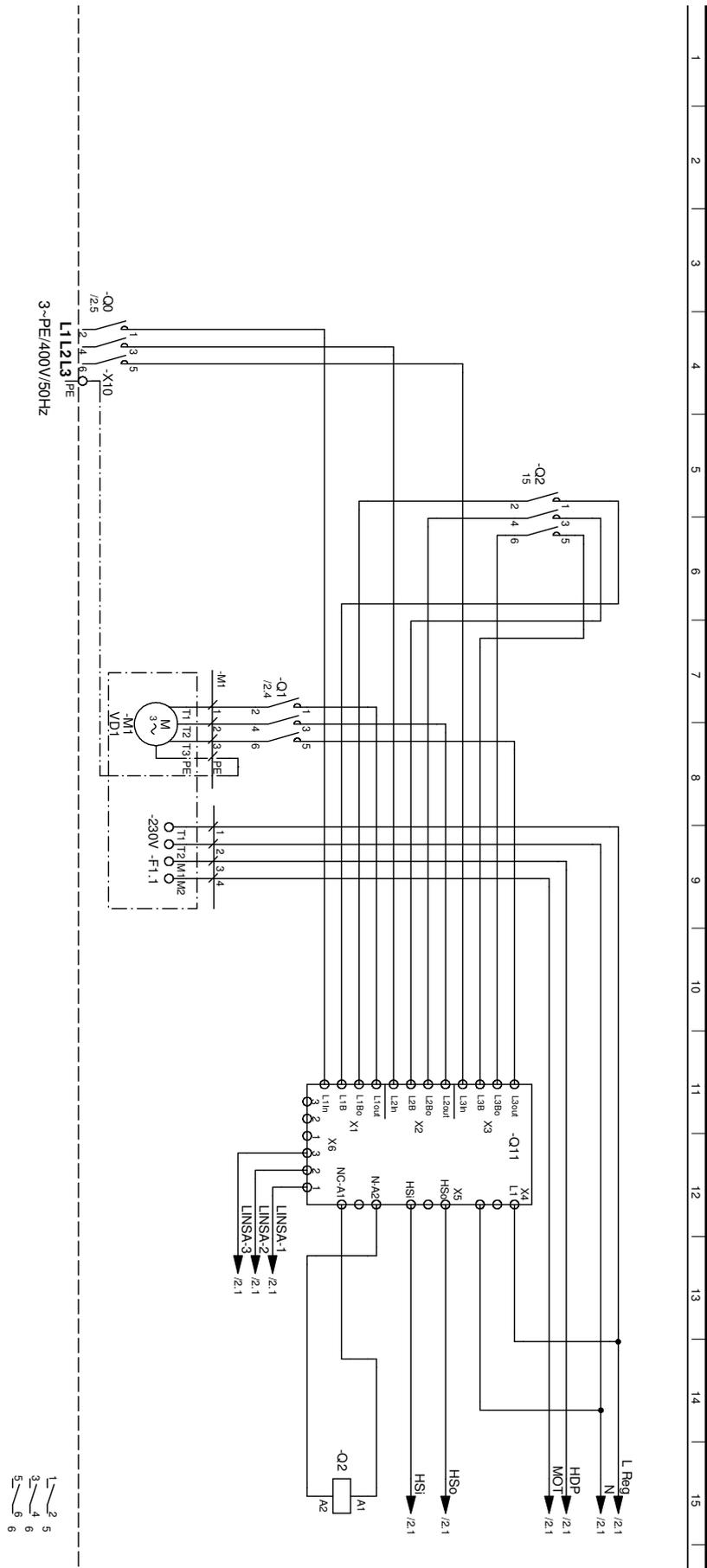



Circuit diagram 2/3

AP-BW30-58, AP-BW30-69, AP-BW30-56H

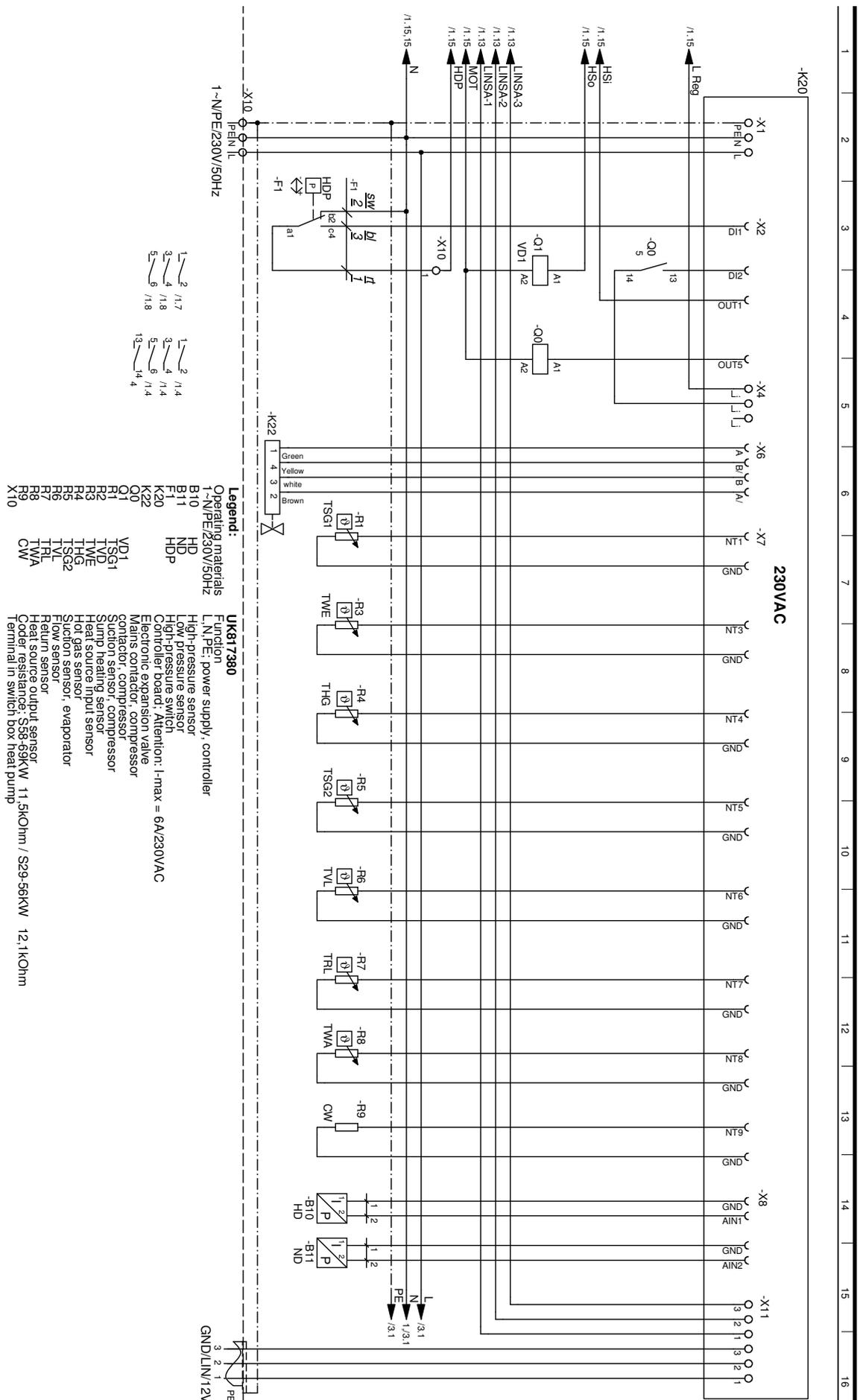

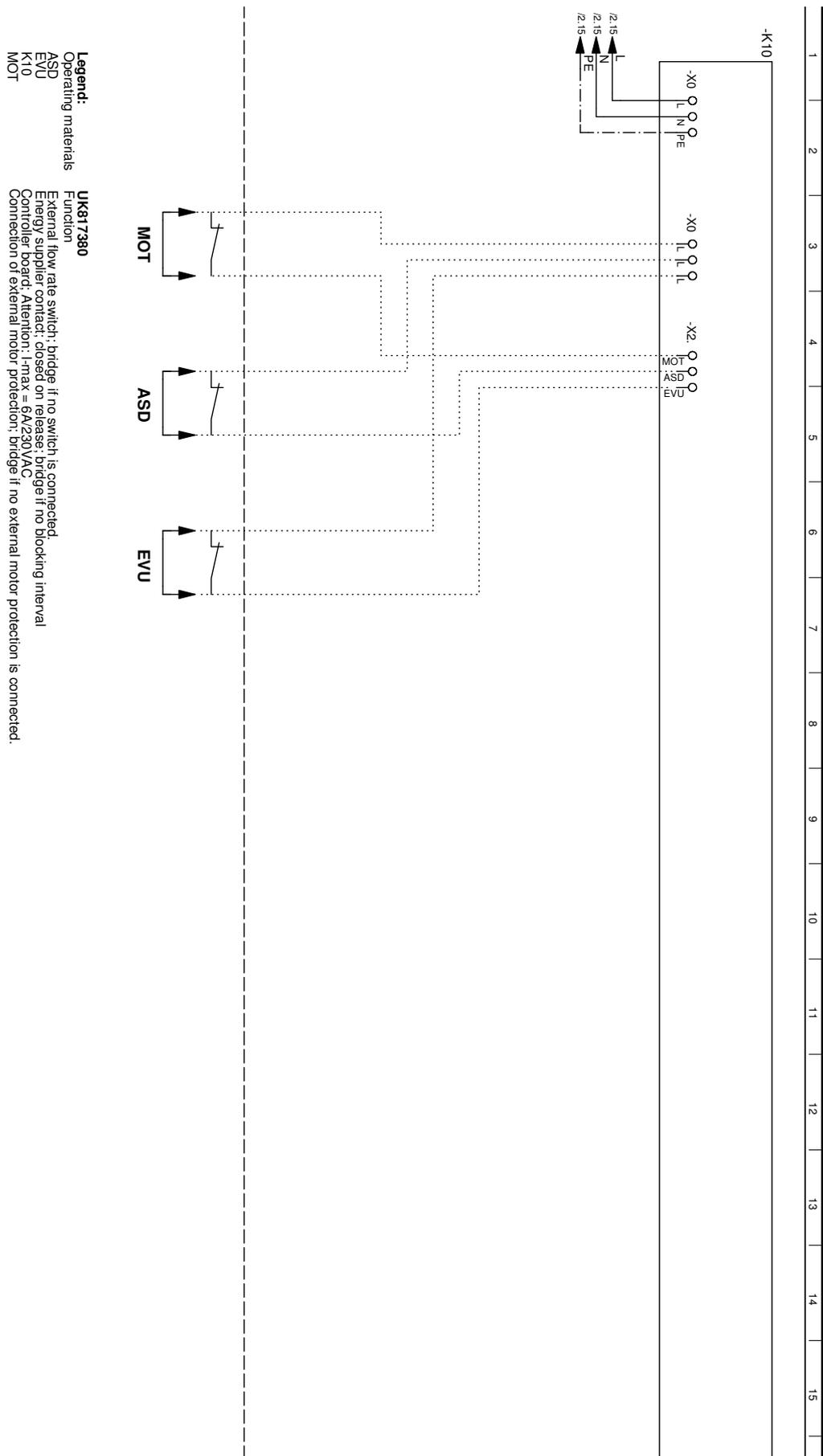



AP-BW30-29H

Circuit diagram 1/3

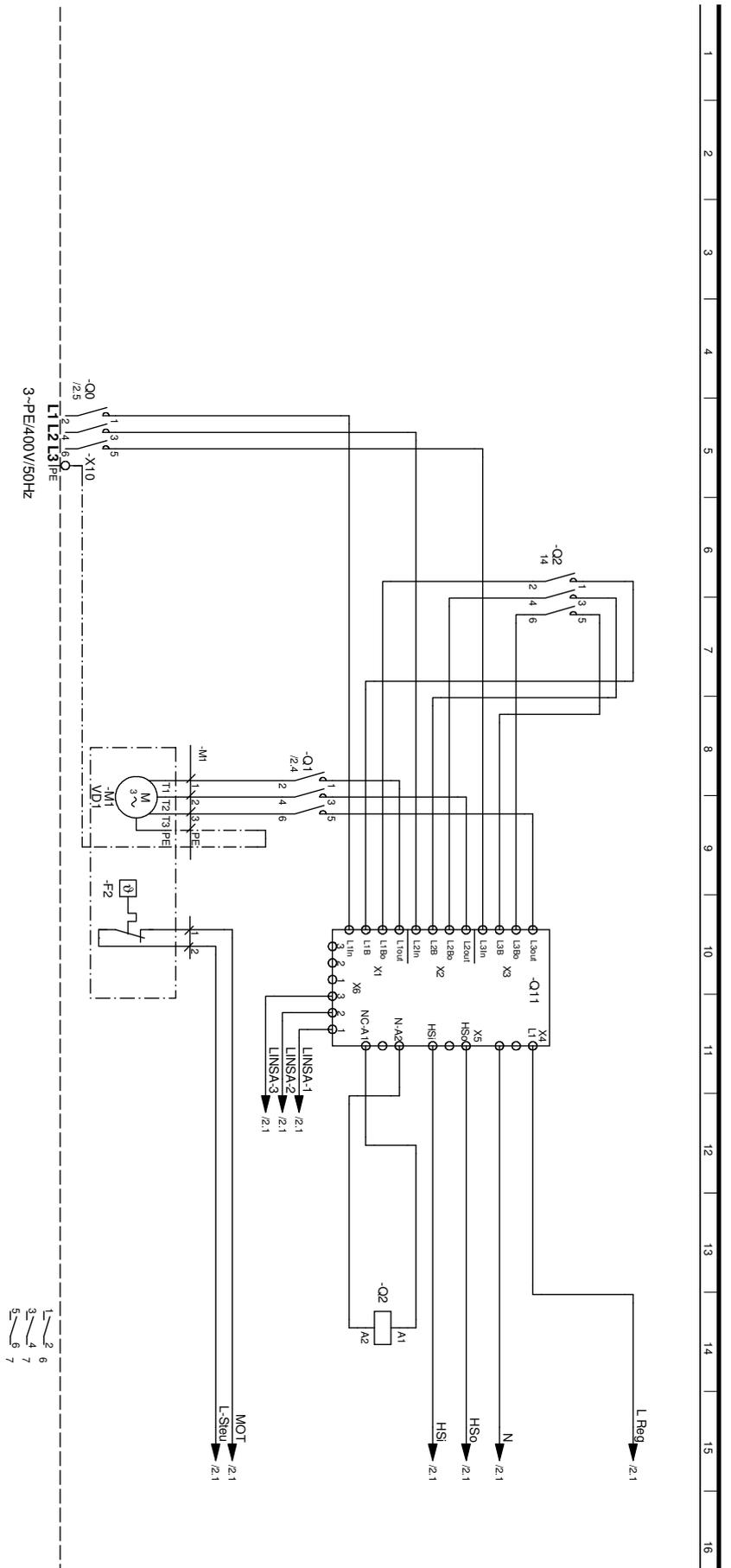

- Legend:**
- Operating materials
 - 3-PE/400V/50Hz
 - F2
 - M7
 - Q1
 - Q2
 - Q11
 - X10
 - UK817385a
 - Function
 - L1, L2, L3, PE: power supply, output, compressor, clockwise rotary field is absolutely necessary!
 - Compressor motor protection
 - compressor
 - Main contactor, compressor
 - Thermal relay
 - Bypass contactor, soft starter
 - Starting current limit compressor
 - Terminal in switch box heat pump



Circuit diagram 2/3

AP-BW30-29H

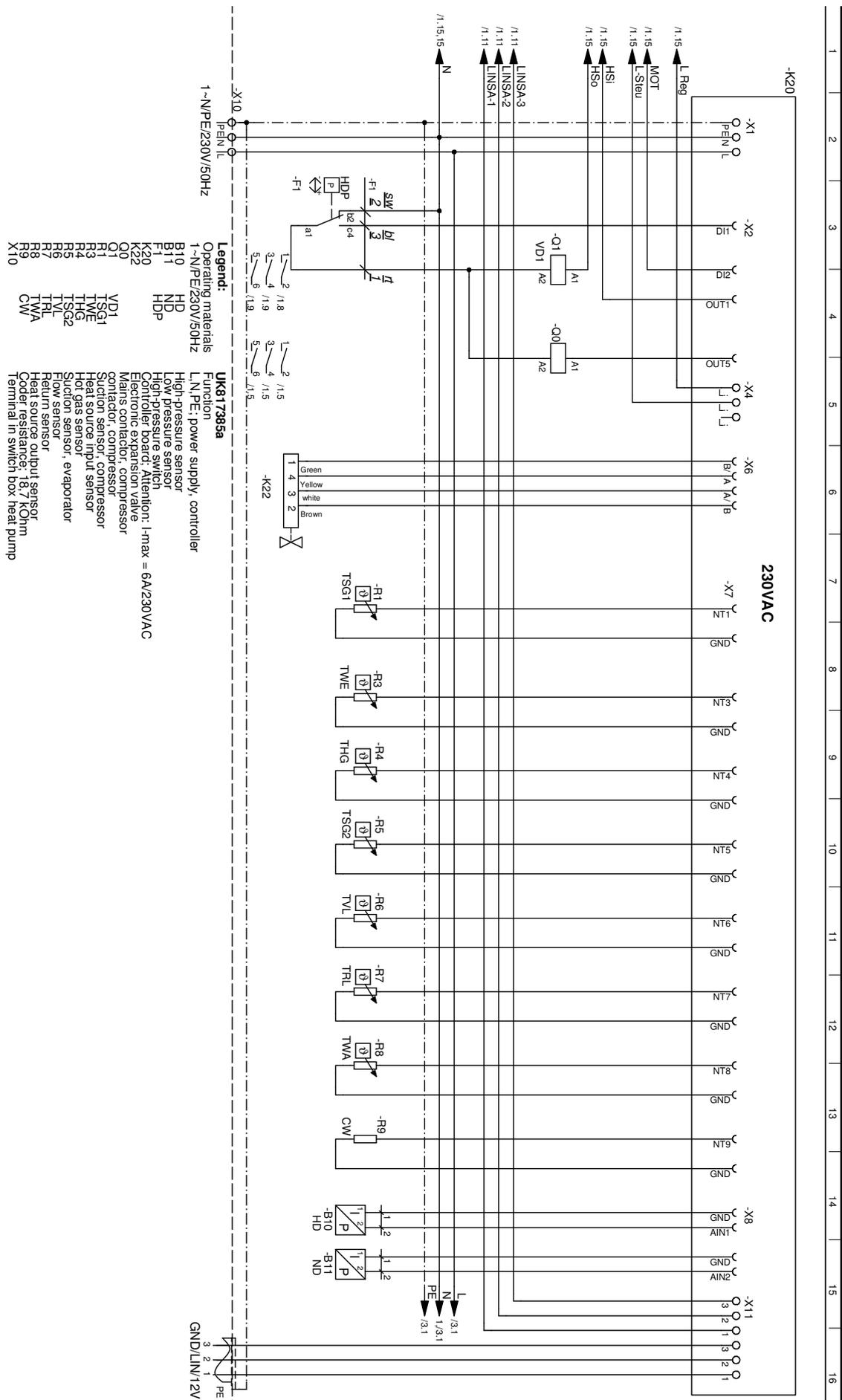

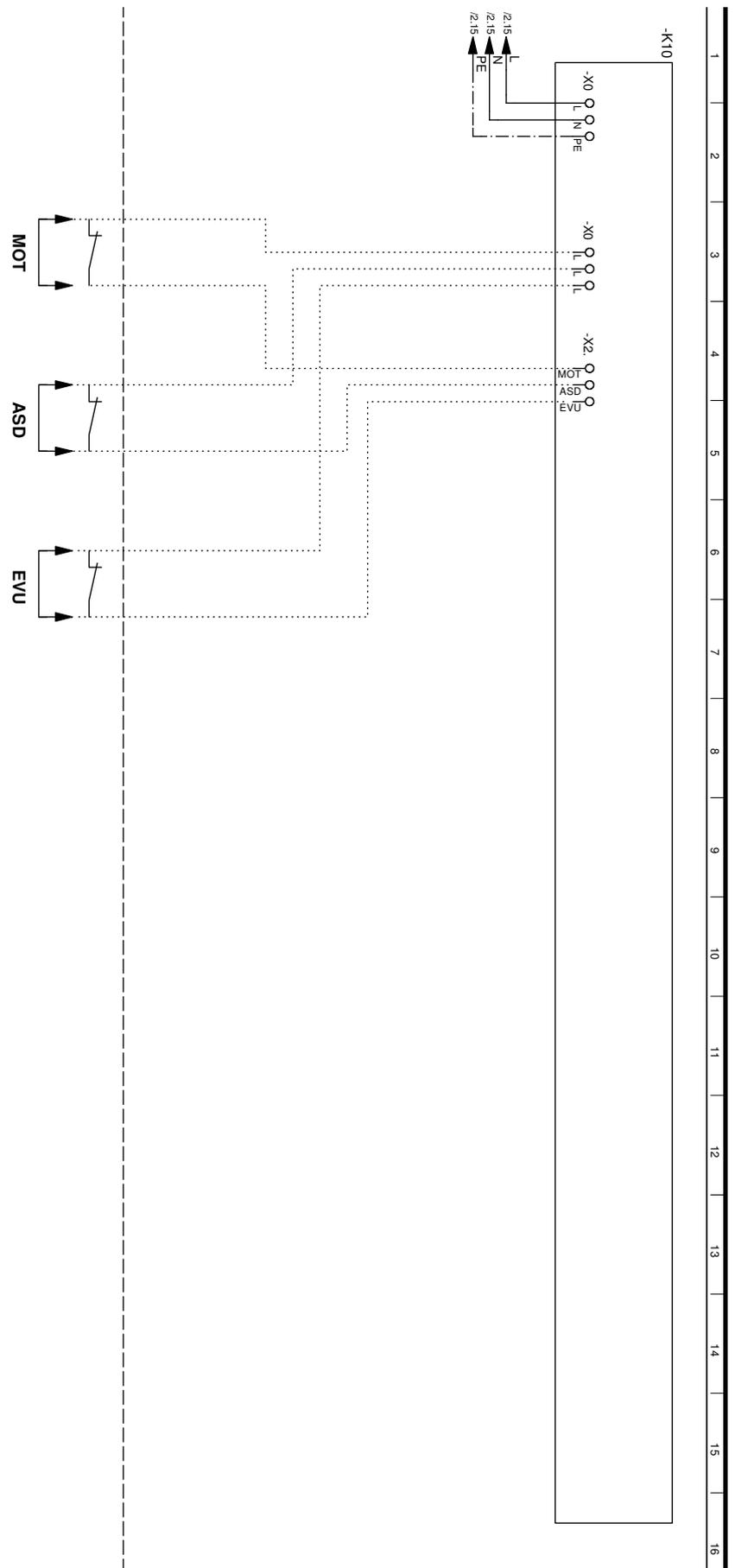

Legend:

Operating materials	UK817385a	Function
ASD		External flow rate switch; bridge if no switch is connected.
EVU		Energy supplier contact; closed on reverse bridge if no blocking interval
K10		Controller board; Attention: I _{max} = 6A/230VAC
MOT		Connection of external motor protection; bridge if no external motor protection is connected.



EC Declaration of Conformity in accordance with the EC Machinery Directive 2006/42/EC, Annex IIA



The undersigned confirms that the following designated device(s) as designed and marketed by us fulfill the standardized EC directives, the EC safety standards and the product-specific EC standards. In the event of modification of the device(s) without our approval, this declaration shall become invalid.

Designation of the device(s)

Heat Pump

Unit model	Number	Unit model	Number
AP-BW30-37*	065285 (106614 02)	AP-AW10-6C	064118 (106440 46)
AP-BW30-45*	065286 (106615 02)	AP-AW10-8C	064119 (106441 46)
AP-BW30-58*	065288 (106616 02)	AP-AW10-10C	064120 (106442 46)
AP-BW30-69*	065289 (106617 02)	AP-AW10-12C	064121 (106443 46)
AP-BW30-29H*	065284 (106618 02)	AP-AW30-25E	064116 (106546 02)
AP-BW30-56H*	065287 (106621 02)	AP-AW30-31E*	064117 (106547 02)
AP-BW30-110*	065290 (106372 04)		
AP-BW30-125*	065291 (106373 04)		
AP-BW30-160*	065292 (106374 04)		
AP-BW30-85H*	065296 (106376 04)		

EC Directives

2006/42/EG

2006/95/EG

2004/108/EG

97/23/EG

2011/65/EG

* Pressure equipment component

Category II

Module A1

Designated position:

TÜV-SÜD

Industrie Service GmbH (Nr.:0036)

Standardized EN

EN 378

EN 60529

EN ISO 12100-1/2

EN ISO 13857

EN 349

EN 60335-1/-2-40

EN 55014-1/-2

EN 61000-3-2/-3-3

Company:

Place, date:

Markaryd 2013-08-15



Signature:

Kenneth Magnusson Quality and Environmental Manager

Signature:

Peter Jovic Business Area Product Manager

