

September 2008

No. OCB439  
REVISED EDITION-A

# PARTS CATALOG

## R410A

[model name]

[Service Ref.]

PUHZ-W50VHA  
PUHZ-W85VHA  
PUHZ-HW112YHA  
PUHZ-HW140VHA  
PUHZ-HW140YHA

PUHZ-W50VHA  
PUHZ-W85VHA  
PUHZ-HW112YHA  
PUHZ-HW140VHA  
PUHZ-HW140YHA

Revision:

- PUHZ-W50V/HW112Y/HW140V/  
HW140YHA are added in REVISED  
EDITION-A.
- "2. OPTIONAL PARTS" is modified.

- Please void OCB439.

Note:

- RoHS compliant products have  
<G> mark on the spec name plate.

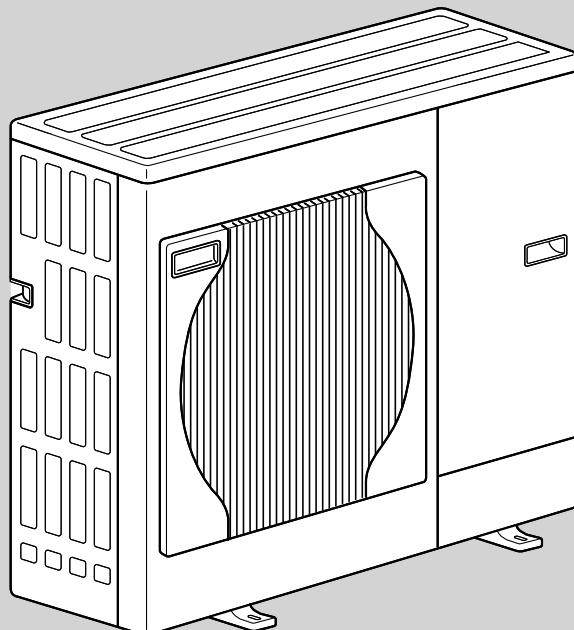

PUHZ-W85VHA

## CONTENTS

1. RoHS PARTS LIST ..... 2
2. OPTIONAL PARTS ..... Back Cover

**SERVICE MANUAL (OCH439)**

**FUNCTIONAL AND ELECTRICAL PARTS**

**PUHZ-W50VHA**

**PUHZ-W85VHA**

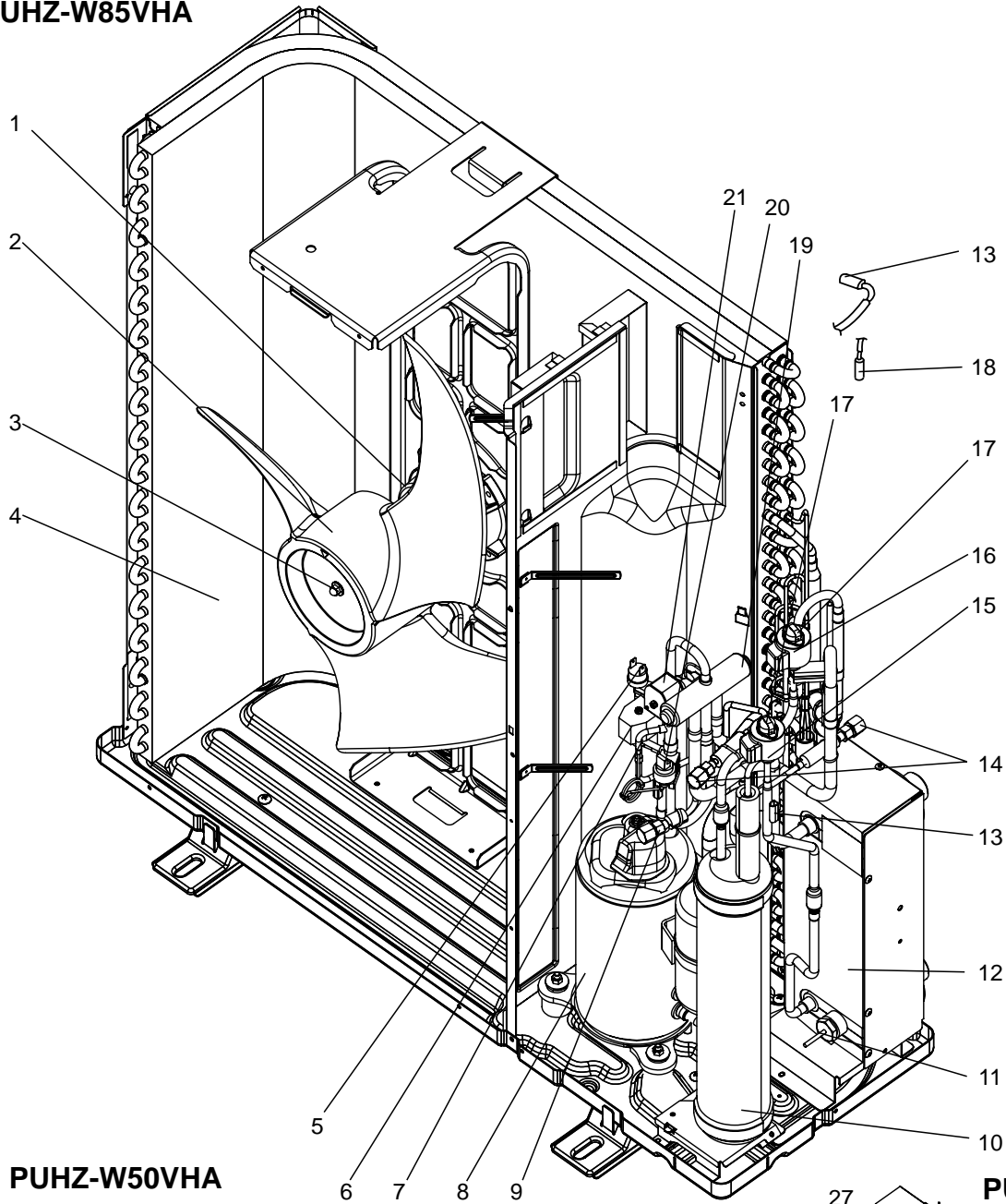

**PUHZ-W50VHA**

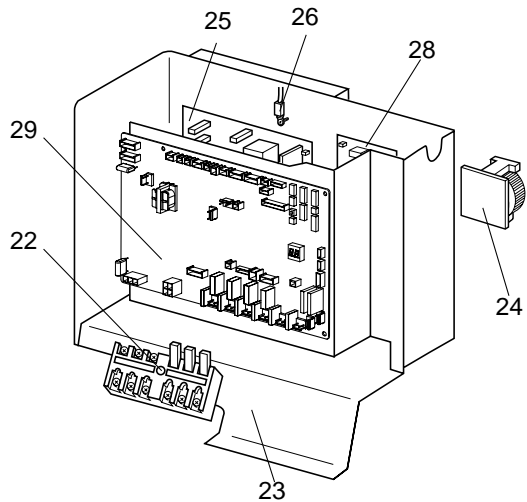

**PUHZ-W85VHA**

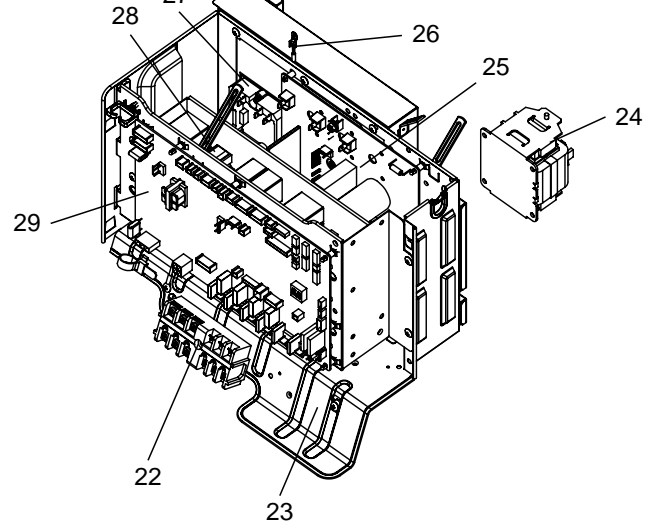

Part numbers that are circled are not shown in the figure.

No.	RoHS	Part No.	Part Name	Specification	Q'ty/unit		Remarks (Drawing No.)	Wiring Diagram Symbol	Recom- mended Q'ty
					PUHZ-W•VHA				
					50	85			
1	G	T7W E27 763	FAN MOTOR		1	1		MF1	
2	G	R01 E08 115	PROPELLER FAN		1	1			
3	G	R01 E09 097	NUT		1	1			
4	G	T7W E50 408	HEAT EXCHANGER		1				
		T7W E47 408	HEAT EXCHANGER			1			
5	G	R01 E06 208	HIGH PRESSURE SWITCH		1	1		63H	
6	G	T7W E52 242	BYPASS VALVE COIL		1			SV	
		T7W E37 242	BYPASS VALVE COIL			1		SV	
7	G	R01 E15 428	BYPASS VALVE		1	1			
8	G	T92 575 280	COMPRESSOR	SNB130FGCM	1		With RUBBER MOUNTS	MC	
		T92 502 801	COMPRESSOR	TNB220FLHM1		1		MC	
9	G	R01 E24 413	CHARGE PLUG		1	1			
10	G	T7W E17 440	RECEIVER		1				
		T7W E15 440	RECEIVER			1			
11	G	T7W E19 202	THERMISTOR (INLET WATER)		1	1		TH32	
12	G	T7W E51 408	PLATE HEAT EXCHANGER	ACH30-30	1				
		T7W E48 408	PLATE HEAT EXCHANGER	ACH30-40		1			
13	G	T7W E58 202	THERMISTOR (PLATE HEX LIQUID, AMBIENT)		1			TH6/TH7	
		R01 E94 202	THERMISTOR (PLATE HEX LIQUID, AMBIENT)			1		TH6/TH7	
14	G	R01 E25 413	CHARGE PLUG		2	2			
15	G	R01 E49 242	LEV COIL	Connector: Red	1	1		LEV-B	
16	G	T7W E50 242	LEV COIL	Connector: White	1	1		LEV-A	
17	G	R01 H22 401	LEV		2	2			
18	G	R01 N03 202	THERMISTOR (OUTDOOR PIPE)		1	1		TH3	
19	G	R01 E29 403	4 WAY VALVE		1				
		R01 E13 403	4 WAY VALVE			1			
20	G	R01 E07 208	HIGH PRESSURE SENSOR		1	1		63HS	
21	G	T7W E39 242	4 WAY VALVE COIL		1			21S4	
		T7W E29 242	4 WAY VALVE COIL			1		21S4	
22	G	T7W E29 716	TERMINAL BLOCK	6P (L, N, ⊕, S1, S2, S3)	1	1		TB1	
23	G	—	ELECTRICAL PARTS BOX		1		(BK00B055G42)		
		—	ELECTRICAL PARTS BOX			1	(BK00B055G40)		
24	G	R01 E33 259	REACTOR		1			DCL	
		T7W E17 259	REACTOR			1		DCL	
25	G	T7W E53 313	POWER CIRCUIT BOARD		1			P.B.	
		T7W E49 313	POWER CIRCUIT BOARD			1		P.B.	
26	G	R01 E99 202	THERMISTOR (HEATSINK)		1	1		TH8	
27	G	T7W E03 233	ACTIVE FILTER MODULE			1		ACTM	
28	G	T7W E21 346	NOISE FILTER CIRCUIT BOARD		1			N.F.	
		R01 E18 346	NOISE FILTER CIRCUIT BOARD			1		N.F.	
29	G	T7W E76 315	CONTROLLER CIRCUIT BOARD		1			C.B.	
		T7W E68 315	CONTROLLER CIRCUIT BOARD			1		C.B.	
③①	G	T7W E06 201	THERMISTOR (DISCHARGE)		1			TH4	
		R01 E09 201	THERMISTOR (DISCHARGE)			1		TH4	
③②	G	—	HEATSINK		1		(BK11C116H14)		
		—	HEATSINK			1	(BK11B272H04)		
③③	G	R01 E06 239	FUSE	250 V 6.3 A	4	4		F1, 2, 3, 4	
③④	G	T7W E07 201	THERMISTOR (COMP. SHELL)		1			TH33	

**FUNCTIONAL AND ELECTRICAL PARTS**  
**PUHZ-HW112YHA**  
**PUHZ-HW140YHA**

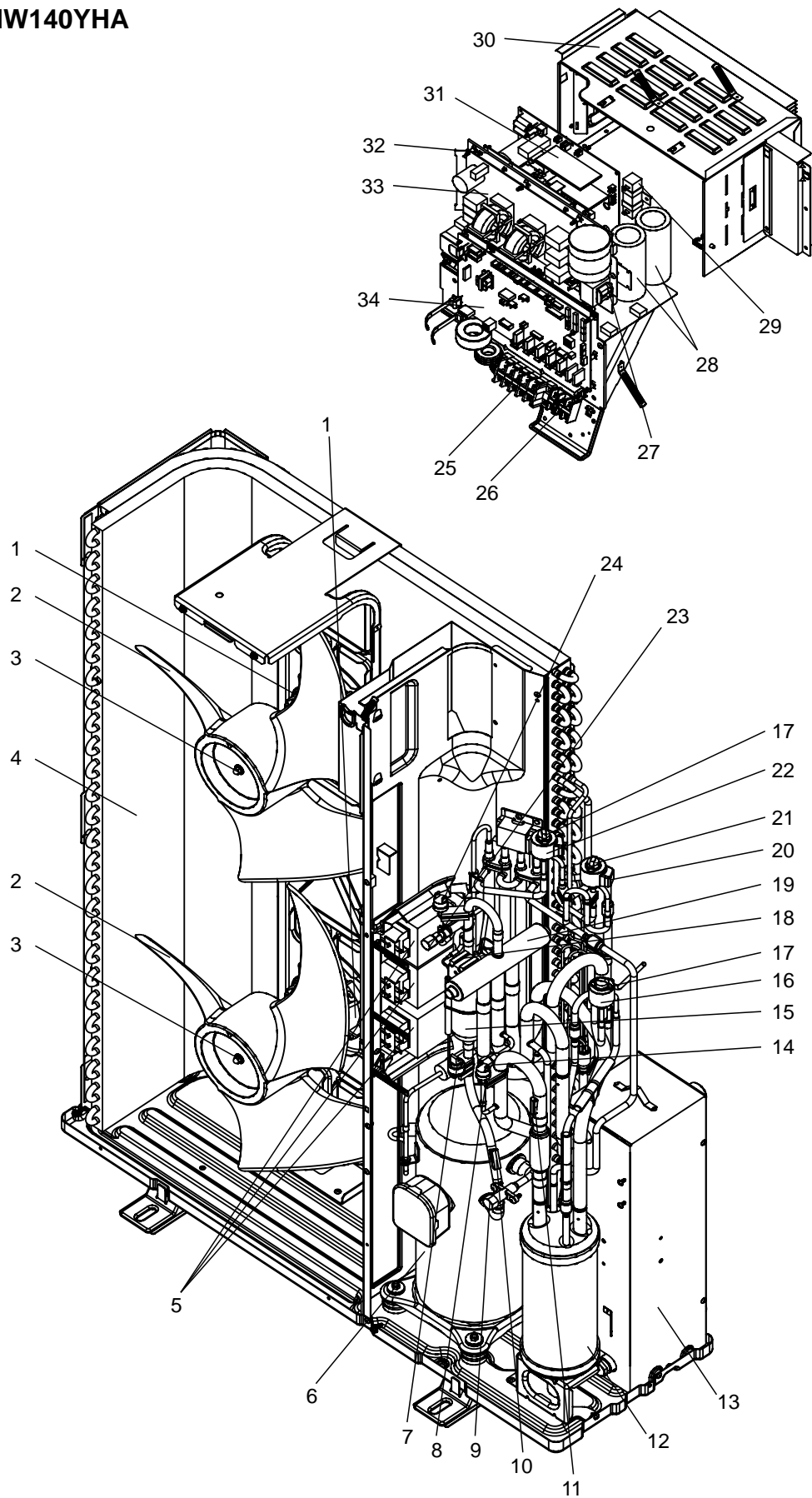

Part numbers that are circled are not shown in the figure.

No.	ROHS	Part No.	Part Name	Specification	Q'ty/unit	Remarks (Drawing No.)	Wiring Diagram Symbol	Recom- mended Q'ty
					PUHZ-HW112/140 YHA			
1	G	R01 E50 221	FAN MOTOR		2		MF1,2	
2	G	R01 E08 115	PROPELLER FAN		2			
3	G	R01 E09 097	NUT		2			
4	G	T7W E52 408	HEAT EXCHANGER		1			
5	G	T7W E12 259	REACTOR		3		ACL1,2,3	
6	G	T97 415 761	COMPRESSOR	ANB33FJFMT	1	with RUBBER MOUNTS	MC	
7	G	R01 E07 208	HIGH PRESSURE SENSOR		1			
8	G	R01 E00 209	LOW PRESSURE SWITCH		1		63L	
9	G	R01 E10 411	STOP VALVE 1/4		1			
10	G	T7W E04 201	THERMISTOR (DISCHARGE)		1		TH4	
11	G	T7W E52 202	THERMISTOR (SUCTION)		1		TH33	
12	G	T7W E18 440	POWER RECEIVER		1			
13	G	T7W E53 408	PLATE HEAT EXCHANGER		1			
14	G	R01 E25 413	CHARGE PLUG		1			
15	G	R01 E10 467	MUFFLER		1			
16	G	R01 E49 242	LEV COIL		1	Connector RED	LEV-B	
17	G	R01 H20 401	LEV		2			
18	G	T7W E29 242	4 WAY VALVE COIL		1		21S4	
19	G	R01 E32 403	4 WAY VALVE		1			
20	G	R01 E68 242	LEV COIL		1	Connector BLUE	LEV-C	
21	G	R01 H22 401	LEV		1			
22	G	R01 E50 242	LEV COIL		1	Connector WHITE	LEV-A	
23	G	R01 E24 413	CHARGE PLUG		1			
24	G	R01 E06 208	HIGH PRESSURE SWITCH		1		63H	
25	G	T7W E30 716	TERMINAL BLOCK	5P	1	L1,L2,L3,N,⊕	TB1	
26	G	R01 E18 246	TERMINAL BLOCK	3P	1	S1,S2,S3	TB2	
27	G	R01 E31 259	REACTOR		1		ACL4	
28	G	R01 E02 254	MAIN SMOOTHING CAPACITOR		2		CB1,2	
29	G	R01 E10 233	RESISTOR		1		RS	
30	G	—	ELECTRICAL PARTS BOX		1	(BK00C410G11)		
31	G	T7W E50 313	POWER BOARD		1		P.B.	
32	G	T7W E75 310	CONVERTER BOARD		1		CONV.B	
33	G	T7W E23 346	NOISE FILTER		1		N.F	
34	G	T7W E72 315	CONTROLLER BOARD		1		C.B	
35	G	R01 H00 202	THERMISTOR (LIQUID)		1		TH3	
36	G	T7W E58 202	THERMISTOR (PLATE HEX LIQUID, AMBIENT)		1		TH6/7	
37	G	T7W E57 202	THERMISTOR (INLET WATER)		1		TH32	
38	G	T7W E10 254	CAPACITOR		1		CK	
39	G	R01 E06 239	FUSE	250 V 6.3 A	4		F1,2,3,4	

# FUNCTIONAL AND ELECTRICAL PARTS PUHZ-HW140VHA

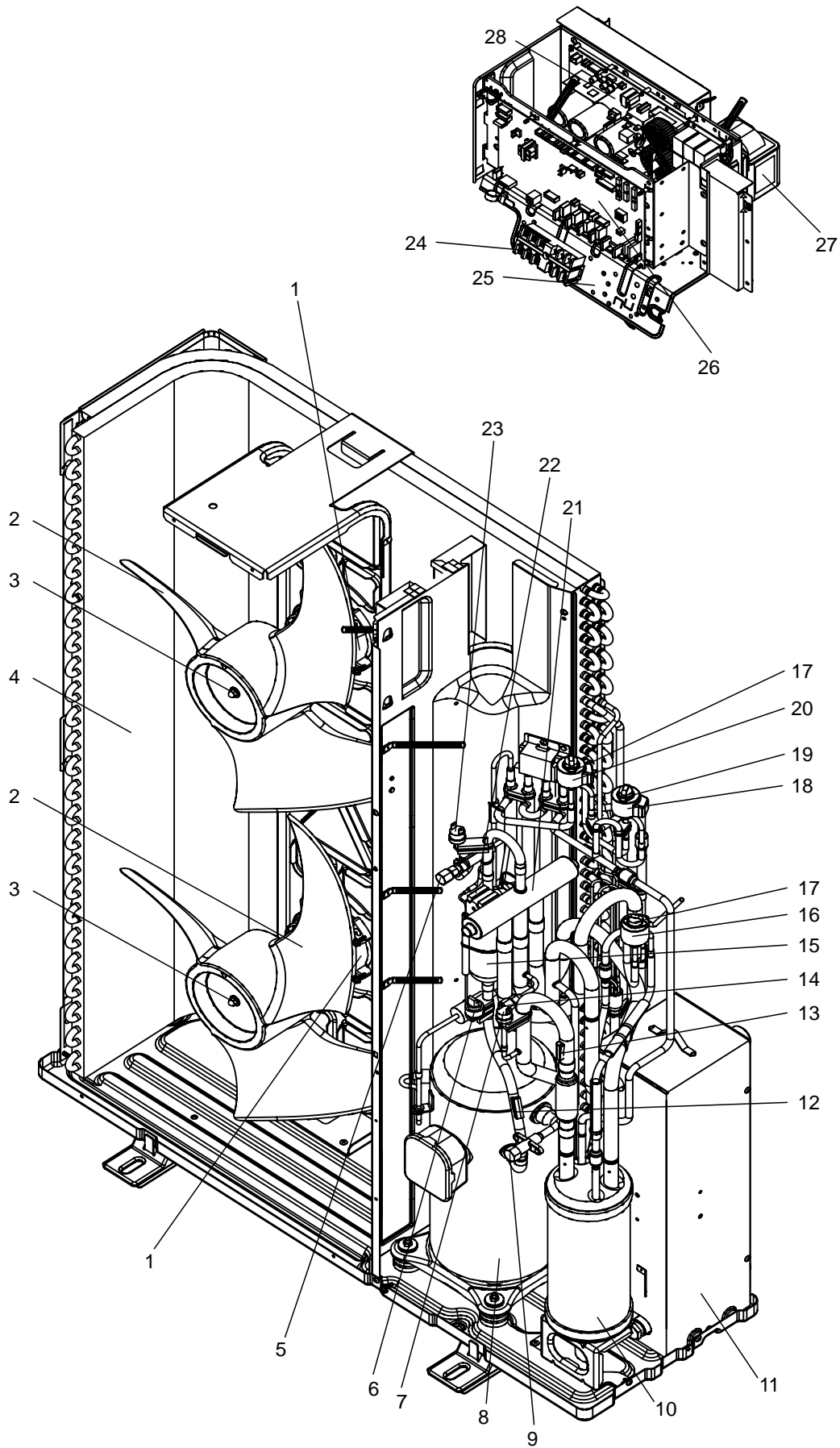

Part numbers that are circled are not shown in the figure.

No.	RoHS	Part No.	Part Name	Specifi-cation	Q'ty/unit	Remarks (Drawing No.)	Wiring Diagram Symbol	Recom- mended Q'ty
					PUHZ-HW140 VHA			
1	G	R01 E50 221	FAN MOTOR		2		MF1,2	
2	G	R01 E08 115	PROPELLER FAN		2			
3	G	R01 E09 097	NUT		2			
4	G	T7W E52 408	HEAT EXCHANGER		1			
5	G	R01 E24 413	CHARGE PLUG		1			
6	G	R01 E07 208	HIGH PRESSURE SENSOR		1		63HS	
7	G	R01 E00 209	LOW PRESSURE SWITCH		1		63L	
8	G	T97 415 762	COMPRESSOR	ANB33FJGMT	1	with RUBBER MOUNTS	MC	
9	G	R01 E10 411	STOP VALVE 1/4		1			
10	G	T7W E18 440	POWER RECEIVER		1			
11	G	T7W E53 408	PLATE HEAT EXCHANGER		1			
12	G	T7W E05 201	THERMISTOR(DISCHARGE)		1		TH4	
13	G	T7W E52 202	THERMISTOR (SUCTION)		1		TH33	
14	G	R01 E25 413	CHARGE PLUG		1			
15	G	R01 E10 467	MUFFLER		1			
16	G	R01 E49 242	LEV COIL		1	Connector RED	LEV-B	
17	G	R01 H20 401	LEV		2			
18	G	R01 E68 242	LEV COIL		1	Connector BLUE	LEV-C	
19	G	R01 H22 401	LEV		1			
20	G	R01 E50 242	LEV COIL		1	Connector WHITE	LEV-A	
21	G	R01 E32 403	4 WAY VALVE		1			
22	G	T7W E41 242	4 WAY VALVE COIL		1		21S4	
23	G	R01 E06 208	HIGH PRESSURE SWITCH		1		63H	
24	G	T7W E29 716	TERMINAL BLOCK	6P	1	L,N,⊕,S1,S2,S3	TB1	
25	G	—	ELECTRICAL PARTS BOX		1	(BK00C681G11)		
26	G	T7W E73 315	CONTROLLER BOARD		1		C.B.	
27	G	T7W E18 259	REACTOR		1		DCL	
28	G	T7W E51 313	POWER BOARD		1		P.B.	
29	G	R01 H00 202	THERMISTOR (LIQUID)		1		TH3	
30	G	T7W E58 202	THERMISTOR (PLATE HEX LIQUID, AMBIENT)		1		TH6/7	
31	G	T7W E57 202	THERMISTOR (INLET WATER)		1		TH32	
32	G	R01 E20 254	MAIN SMOOTHING CAPACITOR		1		CB	
33	G	R01 E06 239	FUSE	250 V 6.3 A	4		F1,2,3,4	

**STRUCTURAL PARTS**  
**PUHZ-W50VHA**  
**PUHZ-W85VHA**

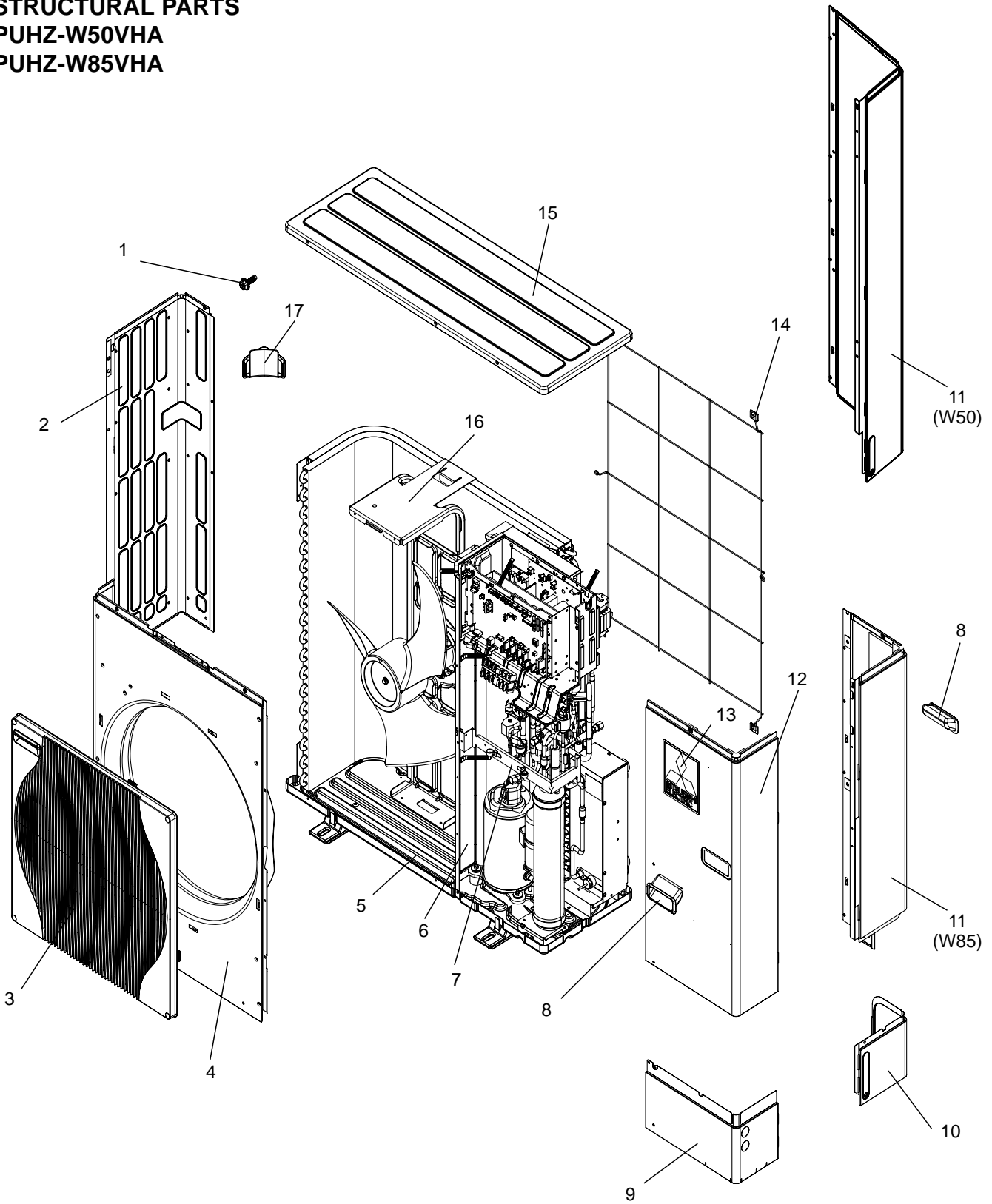





No.	RoHS	Part No.	Part Name	Specification	Q'ty/unit		Remarks (Drawing No.)	Wiring Diagram Symbol	Recom- mended Q'ty
					PUHZ-W•VHA				
					50	85			
1	G	—	F.ST SCREW (5 x 10)		31	31	(DG12F536H10)		
2	G	R01 E18 662	SIDE PANEL (L)		1				
		R01 E16 662	SIDE PANEL (L)			1			
3	G	R01 E33 691	FAN GRILLE		1	1			
4	G	R01 E12 668	FRONT PANEL		1				
		R01 E13 668	FRONT PANEL			1			
5	G	T7W E18 686	BASE		1				
		T7W E17 686	BASE ASSY			1			
6	G	—	SEPARATOR		1		(BK00C143GA4)		
		—	SEPARATOR			1	(BK00C143GA6)		
7	G	—	STAY		1	1	(BK00C125G09)		
8	G	R01 E01 665	HANDLE		2	2			
9	G	T7W E02 658	COVER PANEL (FRONT)		1	1			
10	G	T7W E01 658	COVER PANEL (REAR)			1			
11	G	T7W E23 661	SIDE PANEL (R)		1				
		T7W E21 661	SIDE PANEL (R)			1			
12	G	T7W E11 667	SERVICE PANEL		1				
		T7W E07 668	SERVICE PANEL			1			
13	G	—	LABEL (MITSUBISHI)		1	1	(DG79R130H01)		
14	G	R01 E09 698	REAR GUARD		1				
		R01 E06 698	REAR GUARD			1			
15	G	R01 E14 641	TOP PANEL		1	1			
16	G	R01 E34 130	MOTOR SUPPORT		1				
		R01 E30 130	MOTOR SUPPORT			1			
17	G	R01 E02 655	HANDLE		1	1			

**STRUCTURAL PARTS**  
**PUHZ-HW112YHA**  
**PUHZ-HW140YHA**  
**PUHZ-HW140VHA**

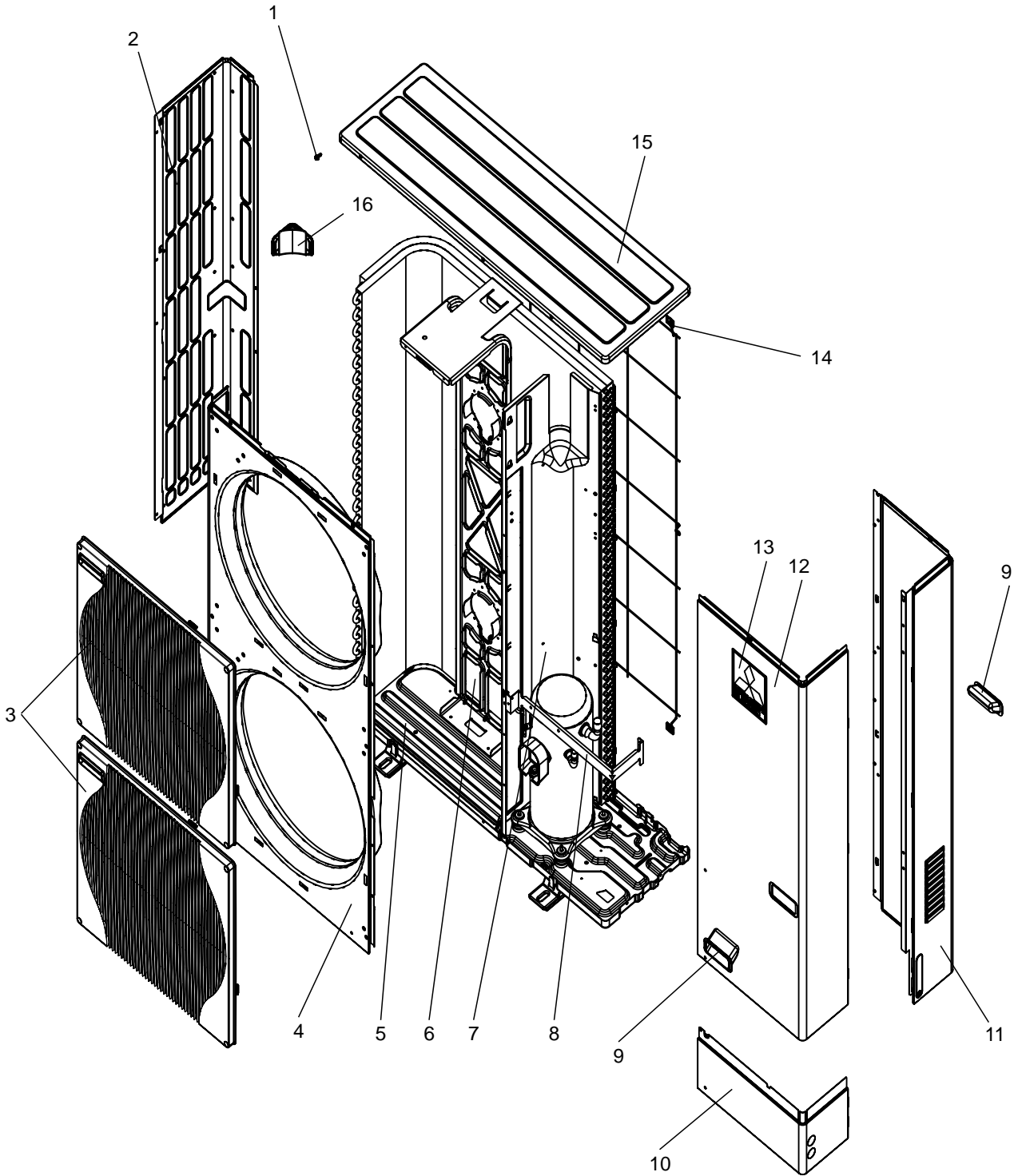



No.	RoHS	Part No.	Part Name	Specification	Q'ty/unit		Remarks (Drawing No.)	Wiring Diagram Symbol	Recom- mended Q'ty
					PUHZ-HW•HA				
					140V	112,140Y			
1	G	—	F.ST SCREW	(5 x 10)	38	38	(DG12F536H10)		
2	G	R01 E20 662	SIDE PANEL (L)		1	1			
3	G	R01 E33 691	FAN GRILLE		2	2			
4	G	R01 E14 668	FRONT PANEL		1	1			
5	G	T7W E19 686	BASE ASSY		1	1			
6	G	R01 E27 130	MOTOR SUPPORT		1	1			
7	G	—	SEPARATOR		1		(BK00C143GB9)		
		—	SEPARATOR			1	(BK00C409G13)		
8	G	—	STAY		1	1	(BK00G125G08)		
9	G	R01 E01 655	HANDLE		2	2			
10	G	T7W E03 658	COVER PANEL (FRONT)		1	1			
11	G	T7W E24 661	SIDE PANEL (R)		1	1			
12	G	T7W E12 667	SERVICE PANEL		1	1			
13	G	—	LABEL (MITSUBISHI)		1	1	(DG79R130H01)		
14	G	R01 E07 698	REAR GUARD		1	1			
15	G	T7W E08 641	TOP PANEL		1				
		T7W E07 641	TOP PANEL			1			
16	G	R01 E02 655	HANDLE		1	1			

## 2

# OPTIONAL PARTS

### 2-1. AIR OUTLET GUIDE (HW112,140 need 2 pieces.)

Part No.	PAC-SG59SG-E
----------	--------------

### 2-2. AIR GUIDE (HW112,140 need 2 pieces.)

Part No.	PAC-SG57AG-E
----------	--------------

### 2-3. DRAIN SOCKET

Part No.	PAC-SG61DS-E
----------	--------------



### 2-4. DRAIN PAN (Only for W50,85)

Part No.	PAC-SG64DP-E
----------	--------------

### 2-5. CONNECTOR FOR DRAIN HOSE HEATER

Part No.	PAC-SE58RA-E
----------	--------------

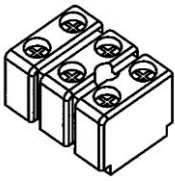
#### Contents

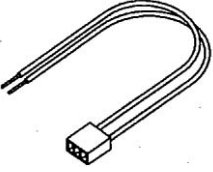
① Terminal block	×1
	
② Screw	×1
	
③ Lead wire with connector	×1
	

#### Installation

##### ●W50/85, HW140VHA

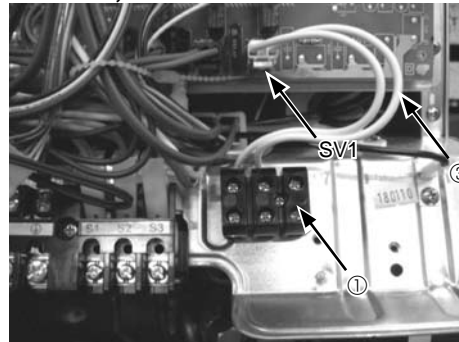

##### ●HW112/140YHA

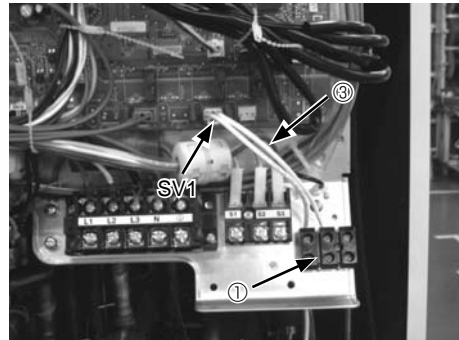

1. Attach the terminal block①, with the screw②.
2. Connect the lead wire③ connector side to SV1 port on the outdoor controller board.
3. Connect the lead wire③ to the terminal block①.
4. Wire local cables for a drain hose heater RELAY to the terminal block①.

- Drain hose heater RELAY connection only
- MAX current 1A

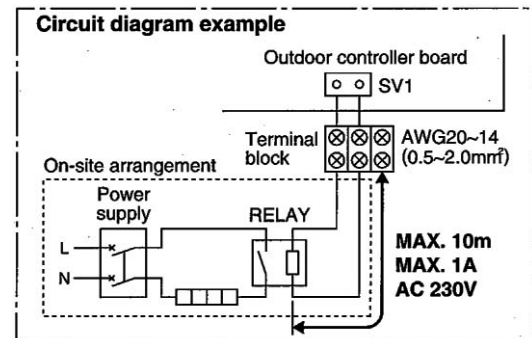

SV1 on the controller board  
→ Drain hose heater signal output  
With PAC-SE58RA-E

From defrost start  
For 15 min. ON signal provided

**MITSUBISHI ELECTRIC CORPORATION**

HEAD OFFICE : TOKYO BLDG., 2-7-3, MARUNOUCHI, CHIYODA-KU, TOKYO 100-8310, JAPAN