

**2014**

# Service Handbook

Model

PWFY-P100VM-E-BU

PWFY-P100, P200VM-E-AU

PWFY-P100, P200VM-E1-AU

PWFY-P100, P200VM-E2-AU

**4th edition**

## Contents

1	Read Before Servicing .....	7
	[1] Items to Be Checked .....	7
	[2] Necessary Tools and Materials .....	8
	[3] Piping Materials .....	9
	[4] Storage of Piping .....	11
	[5] Piping Processing .....	11
	[6] Brazing.....	12
	[7] Air Tightness Test .....	13
	[8] Vacuum Drying (Evacuation) .....	14
	[9] Refrigerant Charging .....	15
	[10] Remedies to be taken in case of a Refrigerant Leak .....	15
	[11] Characteristics of the Conventional and the New Refrigerants ..	16
	[12] Notes on Refrigerating Machine Oil.....	17
2	Restrictions .....	18
	[1] Types and Maximum allowable Length of Cables .....	18
	[2] Types of Switch Setting and Address Setting .....	19
	[3] Examples of system connection .....	20
	[4] Restrictions on piping length .....	21
3	Components of the Unit .....	22
	[1] Appearance of the Components and Refrigerant Circuit.....	22
	[2] Control Box .....	24
	[3] Circuit Board .....	26
4	Remote Controller .....	29
	[1] Functions and Specifications of MA Remote Controller.....	29
	[2] Interlocking Setting via the MA Remote Controller .....	30
5	Electrical Wiring Diagram .....	32
	[1] PWFY-P100VM-E-BU .....	32
	[2] PWFY-P100, 200VM-E-AU, PWFY-P100, 200VM-E1-AU .....	33
	[3] PWFY-P100, 200VM-E2-AU .....	34
6	Refrigerant Circuit .....	35
	[1] Refrigerant Circuit Diagram .....	35
	[2] Pump interlock .....	36
	[3] Functions of Principal Parts.....	37
7	Control.....	39
	[1] Dip Switch Functions and Their Factory Settings .....	39
8	Test Run .....	42
	[1] Check Items before Test Run.....	42
	[2] Test Run Method .....	42
	[3] Refrigerant .....	42
	[4] Symptoms that do not Signify Problems .....	43
	[5] Standard operation data .....	43
9	Troubleshooting .....	44
	[1] Check Code List .....	44
	[2] Responding to Error Display on the Remote Controller .....	45
	[3] Troubleshooting Principal Parts .....	61
	[4] Maintenance .....	75
10	LED display .....	80
	[1] LED Monitor Display .....	80



# Safety Precautions

- Before installing the unit, thoroughly read the following safety precautions.
- Observe these safety precautions for your safety.



## WARNING

This symbol is intended to alert the user to the presence of important instructions that must be followed to avoid the risk of serious injury or death.



## CAUTION

This symbol is intended to alert the user to the presence of important instructions that must be followed to avoid the risk of serious injury or damage to the unit.

- After reading this manual, give it to the user to retain for future reference.
  - Keep this manual for easy reference. When the unit is moved or repaired, give this manual to those who provide these services.
- When the user changes, make sure that the new user receives this manual.



## WARNING

**Do not use refrigerant other than the type indicated in the manuals provided with the unit and on the nameplate.**

Doing so may cause the unit or pipes to burst, or result in explosion or fire during use, during repair, or at the time of disposal of the unit.

It may also be in violation of applicable laws. MITSUBISHI ELECTRIC CORPORATION cannot be held responsible for malfunctions or accidents resulting from the use of the wrong type of refrigerant.

**Do not use steel pipes as water pipes.**

Copper pipes are recommended.

**The water circuit should be a closed circuit.**

**Ask your dealer or a qualified technician to install the unit.**

Improper installation by the user may result in water leakage, electric shock, smoke, and/or fire.

**Properly install the unit on a surface that can withstand the weight of the unit.**

Unit installed on an unstable surface may fall and cause injury.

**Only use specified cables. Securely connect each cable so that the terminals do not carry the weight of the cable.**

Improperly connected or fixed cables may produce heat and start a fire.

**Take appropriate safety measures against strong winds and earthquakes to prevent the unit from falling.**

If the unit is not installed properly, the unit may fall and cause serious injury to the person or damage to the unit.

**Do not make any modifications or alterations to the unit. Consult your dealer for repair.**

Improper repair may result in water leakage, electric shock, smoke, and/or fire.

**Do not touch the refrigerant pipes and Water pipes.**

Improper handling may result in injury.

**In the event of a refrigerant leak, thoroughly ventilate the room.**

If refrigerant gas leaks and comes in contact with an open flame, poisonous gases will be produced.

**Properly install the unit according to the instructions in the installation manual.**

Improper installation may result in water leakage, electric shock, smoke, and/or fire.

**Have all electrical work performed by an authorized electrician according to the local regulations and instructions in this manual, and a dedicated circuit must be used.**

Insufficient capacity of the power supply circuit or improper installation may result in malfunctions of the unit, electric shock, smoke, and/or fire.

 **WARNING**

**Securely attach the terminal block cover (panel) to the unit.**

If the terminal block cover (panel) is not installed properly, dust and/or water may infiltrate and pose a risk of electric shock, smoke, and/or fire.

**Only use the type of refrigerant that is indicated on the unit when installing or reinstalling the unit.**

Infiltration of any other type of refrigerant or air into the unit may adversely affect the refrigerant cycle and may cause the pipes to burst or explode.

**When installing the unit in a small room, exercise caution and take measures against leaked refrigerant reaching the limiting concentration.**

Consult your dealer with any questions regarding limiting concentrations and for precautionary measures before installing the unit. Leaked refrigerant gas exceeding the limiting concentration causes oxygen deficiency.

**Consult your dealer or a specialist when moving or reinstalling the unit.**

Improper installation may result in water leakage, electric shock, and/or fire.

**After completing the service work, check for a gas leak.**

If leaked refrigerant is exposed to a heat source, such as a fan heater, stove, or electric grill, poisonous gases may be produced.

**Do not try to defeat the safety features of the unit.**

Forced operation of the pressure switch or the temperature switch by defeating the safety features of these devices, or the use of accessories other than the ones that are recommended by MITSUBISHI may result in smoke, fire, and/or explosion.

**Only use accessories recommended by MITSUBISHI.**

Ask a qualified technician to install the unit. Improper installation by the user may result in water leakage, electric shock, smoke, and/or fire.

**Control box houses high-voltage parts.**

When opening or closing the front panel of the control box, do not let it come into contact with any of the internal components. Before inspecting the inside of the control box, turn off the power, keep the unit off for at least 10 minutes, and confirm that the voltage between FT-P and FT-N on INV Board has dropped to DC20V or less. (It takes about 10 minutes to discharge electricity after the power supply is turned off.)

## Precautions for handling units for use with R410A

### CAUTION

#### **Do not use the existing refrigerant piping.**

- A large amount of chlorine that may be contained in the residual refrigerant and refrigerating machine oil in the existing piping may cause the refrigerating machine oil in the new unit to deteriorate.
- R410A is a high-pressure refrigerant and can cause the existing pipes to burst.

#### **Use refrigerant pipes made of phosphorus deoxidized copper. Keep the inner and outer surfaces of the pipes clean and free of such contaminants as sulfur, oxides, dust, dirt, shaving particles, oil, and water.**

These types of contaminants inside the refrigerant pipes may cause the refrigerant oil to deteriorate.

#### **Store the pipes to be installed indoors, and keep both ends of the pipes sealed until immediately before brazing. (Keep elbows and other joints wrapped in plastic.)**

Infiltration of dust, dirt, or water into the refrigerant system may cause the refrigerating machine oil to deteriorate or cause the unit to malfunction.

#### **Use a small amount of ester oil, ether oil, or alkylbenzene to coat flares and flanges.**

Infiltration of a large amount of mineral oil may cause the refrigerating machine oil to deteriorate.

#### **Charge liquid refrigerant (as opposed to gaseous refrigerant) into the system.**

If gaseous refrigerant is charged into the system, the composition of the refrigerant in the cylinder will change and may result in performance loss.

#### **Use a vacuum pump with a reverse-flow check valve.**

If a vacuum pump that is not equipped with a reverse-flow check valve is used, the vacuum pump oil may flow into the refrigerant cycle and cause the refrigerating machine oil to deteriorate.

#### **Prepare tools for exclusive use with R410A. Do not use the following tools if they have been used with the conventional refrigerant (gauge manifold, charging hose, gas leak detector, reverse-flow check valve, refrigerant charge base, vacuum gauge, and refrigerant recovery equipment.).**

- If the refrigerant or the refrigerating machine oil left on these tools are mixed in with R410A, it may cause the refrigerating machine oil to deteriorate.
- Infiltration of water may cause the refrigerating machine oil to deteriorate.
- Gas leak detectors for conventional refrigerants will not detect an R410A leak because R410A is free of chlorine.

#### **Do not use a charging cylinder.**

If a charging cylinder is used, the composition of the refrigerant will change, and the unit may experience power loss.

#### **Exercise special care when handling the tools for use with R410A.**

Infiltration of dust, dirt, or water into the refrigerant system may cause the refrigerating machine oil to deteriorate.

#### **Only use refrigerant R410A.**

The use of other types of refrigerant that contain chlorine (i.e. R22) may cause the refrigerating machine oil to deteriorate.

## Before installing the unit

### WARNING

#### **Do not install the unit where a gas leak may occur.**

If gaseous refrigerant leaks and piles up around the unit, it may be ignited.

#### **Do not use the unit to keep food items, animals, plants, artifacts, or for other special purposes.**

The unit is not designed to preserve food products.

#### **Do not use the unit in an unusual environment.**

- ♦ Do not install the unit where a large amount of oil or steam is present or where acidic or alkaline solutions or chemical sprays are used frequently. Doing so may lead to a remarkable drop in performance, electric shock, malfunctions, smoke, and/or fire.
- ♦ The presence of organic solvents or corrosive gas (i.e. ammonia, sulfur compounds, and acid) may cause gas leakage or water leakage.

#### **When installing the unit in a hospital, take appropriate measures to reduce noise interference.**

High-frequency medical equipment may interfere with the normal operation of the air conditioner or vice versa.

#### **Do not install the unit on or over things that cannot get wet.**

When the humidity level exceeds 80% or if the drainage system is clogged, the indoor unit may drip water. Drain water is also discharged from the outdoor unit. Install a centralized drainage system if necessary.

## Before installing the unit (moving and reinstalling the unit) and performing electrical work

### CAUTION

#### **Properly ground the unit.**

Do not connect the grounding wire to a gas pipe, water pipe, lightning rod, or grounding wire from a telephone pole. Improper grounding may result in electric shock, smoke, fire, and/or malfunction due to noise interference.

#### **Do not put tension on the power supply wires.**

If tension is put on the wires, they may break and result in excessive heat, smoke, and/or fire.

#### **Install an earth leakage breaker to avoid the risk of electric shock.**

Failure to install an earth leakage breaker may result in electric shock, smoke, and/or fire.

#### **Use the kind of power supply wires that are specified in the installation manual.**

The use of wrong kind of power supply wires may result in current leak, electric shock, and/or fire.

#### **Use breakers and fuses (current breaker, remote switch <switch + Type-B fuse>, moulded case circuit breaker) with the proper current capacity.**

The use of wrong capacity fuses, steel wires, or copper wires may result in malfunctions, smoke, and/or fire.

#### **Do not spray water on the unit or immerse the air conditioner in water.**

Otherwise, electric shock and/or fire may result.

**When handling units, always wear protective gloves to protect your hands from metal parts and high-temperature parts.**

#### **Periodically check the installation base for damage.**

If the unit is left on a damaged platform, it may fall and cause injury.

#### **Properly install the drain pipes according to the instructions in the installation manual. Keep them insulated to avoid dew condensation.**

Improper plumbing work may result in water leakage and damage to the furnishings.

#### **Exercise caution when transporting products.**

- ♦ Products weighing more than 20 kg should not be carried alone.
- ♦ Do not carry the product by the PP bands that are used on some products.

#### **Properly dispose of the packing materials.**

- ♦ Nails and wood pieces in the package may pose a risk of injury.
- ♦ Plastic bags may pose a risk of choking hazard to children. Tear plastic bags into pieces before disposing of them.



## Before the test run

 **CAUTION**

**Turn on the unit at least 12 hours before the test run.**

Keep the unit turned on throughout the season. If the unit is turned off in the middle of a season, it may result in malfunctions.

**To avoid the risk of electric shock or malfunction of the unit, do not operate switches with wet hands.**

**Do not touch the refrigerant pipes with bare hands during and immediately after operation.**

During or immediately after operation, certain parts of the unit such as pipes and compressor may be either very cold or hot, depending on the state of the refrigerant in the unit at the time. To reduce the risk of frost bites and burns, do not touch these parts with bare hands.

**Do not operate the unit without panels and safety guards.**

Rotating, high-temperature, or high-voltage parts on the unit pose a risk of burns and/or electric shock.

**Do not turn off the power immediately after stopping the operation.**

Keep the unit on for at least five minutes before turning off the power to prevent water leakage or malfunction.

**Do not operate the unit without the air filter.**

Dust particles may build up in the system and cause malfunctions.

## 1 Read Before Servicing

### [1] Items to Be Checked

1. Check the type of refrigerant used in the system to be serviced.

#### Refrigerant Type

	PWFY-P100VM-E-BU	PWFY-P100, 200VM-E-AU PWFY-P100, 200VM-E1-AU PWFY-P100, 200VM-E2-AU
Between unit and BC controller	R410A	R410A
Inside the unit	R134a	-

2. Check the symptoms exhibited by the unit to be serviced.

Refer to this service handbook for symptoms relating to the refrigerant cycle.

3. Thoroughly read the safety precautions at the beginning of this manual.

4. Preparing necessary tools: Prepare a set of tools to be used exclusively with each type of refrigerant.

Refer to "Necessary Tools and Materials" for information on the use of tools.(page 8)

5. Verification of the connecting pipes: Verify the type of refrigerant used for the unit to be moved or replaced.

- Use refrigerant pipes made of phosphorus deoxidized copper. Keep the inner and outer surfaces of the pipes clean and free of such contaminants as sulfur, oxides, dust, dirt, shaving particles, oil, and water.
- These types of contaminants inside the refrigerant pipes may cause the refrigerant oil to deteriorate.

6. If there is a leak of gaseous refrigerant and the remaining refrigerant is exposed to an open flame, a poisonous gas hydrofluoric acid may form. Keep workplace well ventilated.



#### CAUTION

- Install new pipes immediately after removing old ones to keep moisture out of the refrigerant circuit.
- The use of refrigerant that contains chloride, such as R22, will cause the refrigerating machine oil to deteriorate.

## [2] Necessary Tools and Materials

Prepare the following tools and materials necessary for installing and servicing the unit.

### Tools for use with R410A (Adaptability of tools that are for use with R22 or R407C)

#### 1. To be used exclusively with R410A (not to be used if used with R22 or R407C)

Tools/Materials	Use	Notes
Gauge Manifold	Evacuation and refrigerant charging	Higher than 5.09MPa[738psi] on the high-pressure side
Charging Hose	Evacuation and refrigerant charging	The hose diameter is larger than the conventional model.
Refrigerant Recovery Cylinder	Refrigerant recovery	
Refrigerant Cylinder	Refrigerant charging	The refrigerant type is indicated. The cylinder is pink.
Charging Port on the Refrigerant Cylinder	Refrigerant charging	The charge port diameter is larger than that of the current port.
Flare Nut	Connection of the unit with the pipes	Use Type-2 Flare nuts.

#### 2. Tools and materials that may be used with R410A with some restrictions

Tools/Materials	Use	Notes
Gas Leak Detector	Gas leak detection	The ones for use with HFC refrigerant may be used.
Vacuum Pump	Vacuum drying	May be used if a check valve adapter is attached.
Flare Tool	Flare processing	Flare processing dimensions for the piping in the system using the new refrigerant differ from those of R22. Refer to next page.
Refrigerant Recovery Equipment	Refrigerant recovery	May be used if compatible with R410A or R134a

#### 3. Tools and materials that are used with R22 or R407C that may also be used with R410A

Tools/Materials	Use	Notes
Vacuum Pump with a Check Valve	Vacuum drying	
Bender	Bending pipes	
Torque Wrench	Tightening flare nuts	Only the flare processing dimensions for pipes that have a diameter of $\phi 12.70$ (1/2") and $\phi 15.88$ (5/8") have been changed.
Pipe Cutter	Cutting pipes	
Welder and Nitrogen Cylinder	Welding pipes	
Refrigerant Charging Meter	Refrigerant charging	
Vacuum Gauge	Vacuum level check	

#### 4. Tools and materials that must not be used with R410A

Tools/Materials	Use	Notes
Charging Cylinder	Refrigerant charging	Prohibited to use

Tools for R410A must be handled with special care to keep moisture and dust from infiltrating the cycle.

### [3] Piping Materials

**Do not use the existing piping!**

#### 1. Copper pipe materials

O-material (Annealed)	Soft copper pipes (annealed copper pipes). They can easily be bent with hands.
1/2H-material (Drawn)	Hard copper pipes (straight pipes). They are stronger than the O-material (Annealed) at the same radial thickness.

- The distinction between O-materials (Annealed) and 1/2H-materials (Drawn) is made based on the strength of the pipes themselves.
- O-materials (Annealed) can easily be bent with hands.
- 1/2H-materials (Drawn) are considerably stronger than O-material (Annealed) at the same thickness.

#### 2. Types of copper pipes

Maximum working pressure	Refrigerant type
4.30 MPa [624psi]	R410A and R134a

#### 3. Piping materials/Radial thickness

Use refrigerant pipes made of phosphorus deoxidized copper.  
 The operation pressure of the units that use R410A is higher than that of the units that use R22.  
 Use pipes that have at least the radial thickness specified in the chart below.  
 (Pipes with a radial thickness of 0.7 mm or less may not be used.)

Pipe size (mm[in])	Radial thickness (mm)	Type
ø6.35 [1/4"]	0.8t	O-material (Annealed)
ø9.52 [3/8"]	0.8t	
ø12.7 [1/2"]	0.8t	
ø15.88 [5/8"]	1.0t	
ø19.05 [3/4"]	1.0t	1/2H-material, H-material (Drawn)
ø22.2 [7/8"]	1.0t	
ø25.4 [1"]	1.0t	
ø28.58 [1-1/8"]	1.0t	
ø31.75 [1-1/4"]	1.1t	
ø34.93 [1-3/8"]	1.1t	
ø41.28 [1-5/8"]	1.2t	

- The pipes in the system that uses the refrigerant currently on the market are made with O-material (Annealed), even if the pipe diameter is less than ø19.05 (3/4"). For a system that uses R410A, use pipes that are made with 1/2H-material (Drawn) unless the pipe diameter is at least ø19.05 (3/4") and the radial thickness is at least 1.2t.
- The figures in the radial thickness column are based on the Japanese standards and provided only as a reference. Use pipes that meet the local standards.

**4. Thickness and refrigerant type indicated on the piping materials**

Ask the pipe manufacturer for the symbols indicated on the piping material for new refrigerant.

**5. Flare processing (O-material (Annealed) and OL-material only)**

The flare processing dimensions for the pipes that are used in the R410A system are larger than those in the R22 system.

Flare processing dimensions (mm[in])

Pipe size (mm[in])	A dimension (mm)
ø6.35 [1/4"]	9.1
ø9.52 [3/8"]	13.2
ø12.7 [1/2"]	16.6
ø15.88 [5/8"]	19.7
ø19.05 [3/4"]	24.0

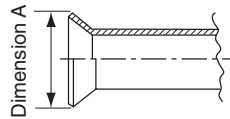

If a clutch-type flare tool is used to flare the pipes in the system using R410A, the length of the pipes must be between 1.0 and 1.5 mm. For margin adjustment, a copper pipe gauge is necessary.

**6. Flare nut**

The flare nut type has been changed to increase the strength. The size of some of the flare nuts have also been changed.

Flare nut dimensions (mm[in])

Pipe size (mm[in])	B dimension (mm)
ø6.35 [1/4"]	17.0
ø9.52 [3/8"]	22.0
ø12.7 [1/2"]	26.0
ø15.88 [5/8"]	29.0
ø19.05 [3/4"]	36.0

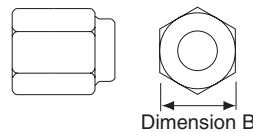

The figures in the radial thickness column are based on the Japanese standards and provided only as a reference. Use pipes that meet the local standards.

## [4] Storage of Piping

### 1. Storage location



Store the pipes to be used indoors. (Warehouse at site or owner's warehouse)  
If they are left outdoors, dust, dirt, or moisture may infiltrate and contaminate the pipe.

### 2. Sealing the pipe ends

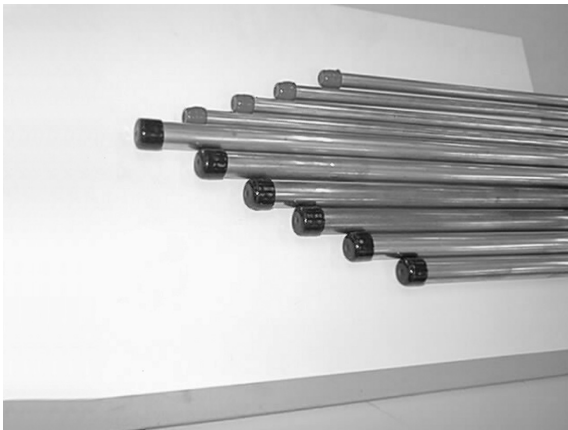

Both ends of the pipes should be sealed until just before brazing.  
Keep elbow pipes and T-joints in plastic bags.

The new refrigerator oil is 10 times as hygroscopic as the conventional refrigerating machine oil (such as Suniso) and, if not handled with care, could easily introduce moisture into the system. Keep moisture out of the pipes, for it will cause the oil to deteriorate and cause a compressor failure.

## [5] Pipe Processing

Use a small amount of ester oil, ether oil, or alkylbenzene to coat flares and flanges.

### Note

- Use a minimum amount of oil.
- Use only ester oil, ether oil, and alkylbenzene.

## [6] Brazing

No changes have been made in the brazing procedures. Perform brazing with special care to keep foreign objects (such as oxide scale, water, and dust) out of the refrigerant system.

Example: Inside the brazed connection

Use of oxidized solder for brazing

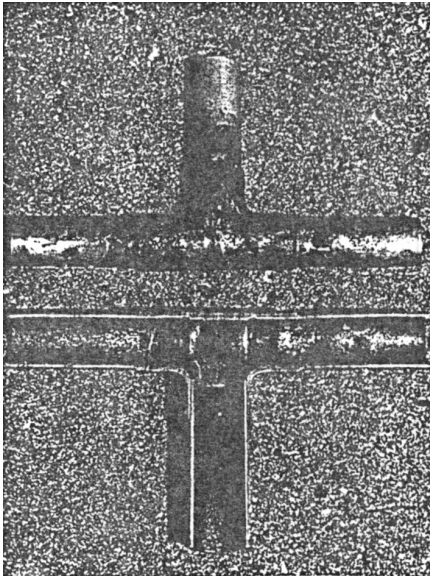

Use of non-oxidized solder for brazing

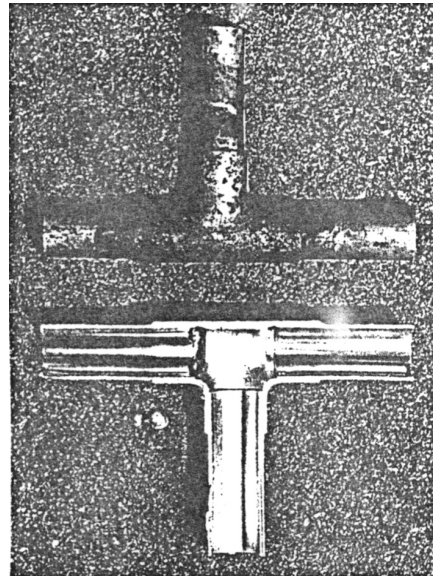

### 1. Items to be strictly observed

- Do not conduct refrigerant piping work outdoors if raining.
- Use non-oxidized solder.
- Use a brazing material (BCuP-3) that requires no flux when brazing between copper pipes or between a copper pipe and copper coupling.
- If installed refrigerant pipes are not immediately connected to the equipment, then braze and seal both ends.

### 2. Reasons

- The new refrigerating machine oil is 10 times as hygroscopic as the conventional oil and is more likely to cause unit failure if water infiltrates into the system.
- Flux generally contains chloride. Residual flux in the refrigerant circuit will cause sludge to form.

### 3. Notes

Do not use commercially available antioxidants because they may cause the pipes to corrode or refrigerating machine oil to deteriorate.

## [7] Air Tightness Test

No changes have been made in the detection method. Note that a refrigerant leak detector for R22 will not detect an R410A leak.

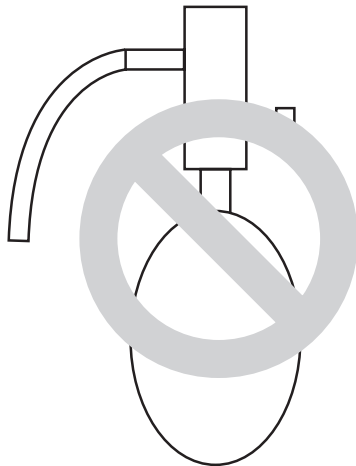

Halide torch

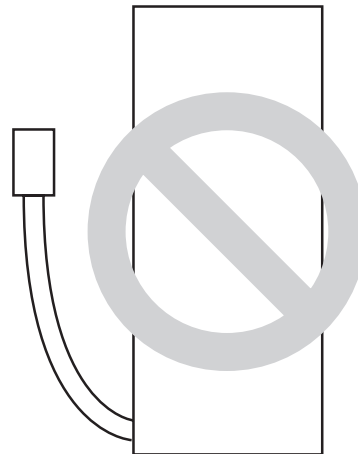

R22 leakage detector

### 1. Items to be strictly observed

- Pressurize the equipment with nitrogen up to the design pressure (4.15MPa[601psi]), and then judge the equipment's air tightness, taking temperature variations into account.
- When using refrigerant instead of a leak detector to find the location of a leak, use R410A.
- Refrigerant R410A must be charged in its liquid state (vs. gaseous state).

### 2. Reasons

- Oxygen, if used for an air tightness test, poses a risk of explosion. (Only use nitrogen to check air tightness.)
- Refrigerant R410A must be charged in its liquid state. If gaseous refrigerant in the cylinder is drawn out first, the composition of the remaining refrigerant in the cylinder will change and become unsuitable for use.

### 3. Notes

Procure a leak detector that is specifically designed to detect an HFC leak. A leak detector for R22 will not detect an HFC(R410A, R407C) leak.



## [8] Vacuum Drying (Evacuation)



(Photo1) 15010H



(Photo2) 14010

Recommended vacuum gauge:  
ROBINAIR 14010 Thermistor Vacuum Gauge

### 1. Vacuum pump with a reverse-flow check valve (Photo1)

To prevent the vacuum pump oil from flowing into the refrigerant circuit during power OFF or power failure, use a vacuum pump with a reverse-flow check valve.

A reverse-flow check valve may also be added to the vacuum pump currently in use.

### 2. Standard of vacuum degree (Photo 2)

Use a vacuum pump that attains 0.5Torr(65Pa) or lower degree of vacuum after 5 minutes of operation, and connect it directly to the vacuum gauge. Use a pump well-maintained with an appropriate lubricant. A poorly maintained vacuum pump may not be able to attain the desired degree of vacuum.

### 3. Required precision of vacuum gauge

Use a vacuum gauge that registers a vacuum degree of 5Torr(650Pa) and measures at intervals of 1Torr(130Pa). (A recommended vacuum gauge is shown in Photo2.)

Do not use a commonly used gauge manifold because it cannot register a vacuum degree of 5Torr(650Pa).

### 4. Evacuation time

- After the degree of vacuum has reached 5Torr(650Pa), evacuate for an additional 1 hour. (A thorough vacuum drying removes moisture in the pipes.)
- Verify that the vacuum degree has not risen by more than 1Torr(130Pa) 1hour after evacuation. A rise by less than 1Torr(130Pa) is acceptable.
- If the vacuum is lost by more than 1Torr(130Pa), conduct evacuation, following the instructions in section 6. Special vacuum drying.

### 5. Procedures for stopping vacuum pump

To prevent the reverse flow of vacuum pump oil, open the relief valve on the vacuum pump side, or draw in air by loosening the charge hose, and then stop the operation.

The same procedures should be followed when stopping a vacuum pump with a reverse-flow check valve.

### 6. Special vacuum drying

- When 5Torr(650Pa) or lower degree of vacuum cannot be attained after 3 hours of evacuation, it is likely that water has penetrated the system or that there is a leak.
- If water infiltrates the system, break the vacuum with nitrogen. Pressurize the system with nitrogen gas to 0.5kgf/cm<sup>2</sup>G(0.05MPa) and evacuate again. Repeat this cycle of pressurizing and evacuation either until the degree of vacuum below 5Torr(650Pa) is attained or until the pressure stops rising.
- Only use nitrogen gas for vacuum breaking. (The use of oxygen may result in an explosion.)

## [9] Refrigerant Charging

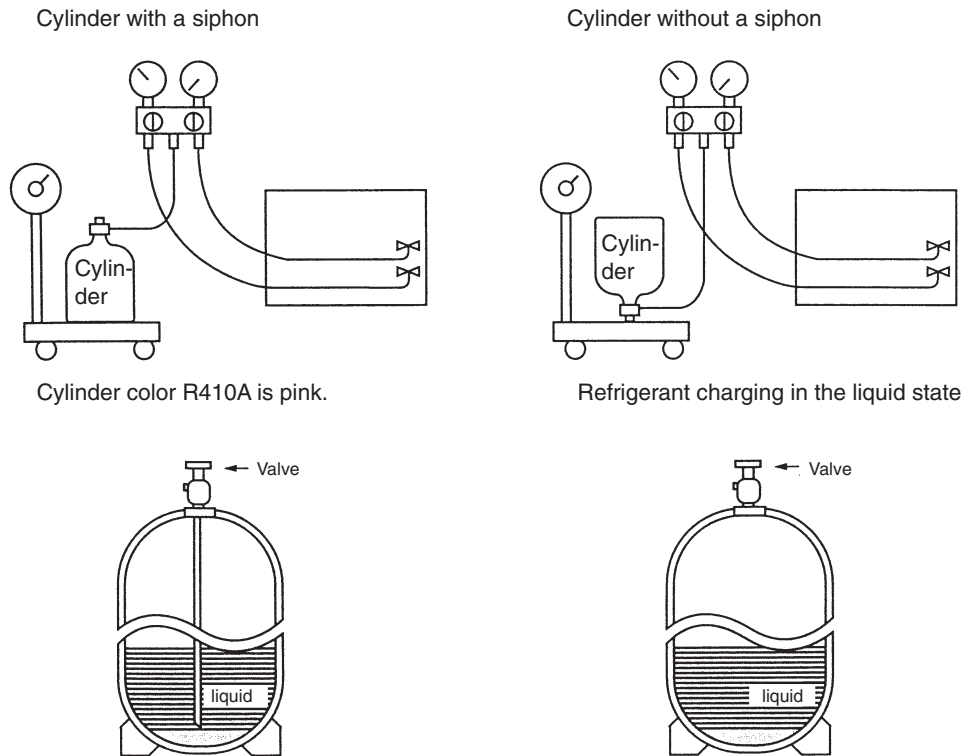

### 1. Reasons

R410A is a pseudo-azeotropic HFC blend (boiling point R32=-52°C[-62°F], R125=-49°C[-52°F]) and can almost be handled the same way as a single refrigerant, such as R22. To be safe, however, draw out the refrigerant from the cylinder in the liquid phase. If the refrigerant in the gaseous phase is drawn out, the composition of the remaining refrigerant will change and become unsuitable for use.

### 2. Notes

When using a cylinder with a siphon, refrigerant is charged in the liquid state without the need for turning it upside down. Check the type of the cylinder on the label before use.

## [10] Remedies to be taken in case of a Refrigerant Leak

If the refrigerant leaks out, it may be replenished. The entire refrigerant does not need to be replaced. (Charge refrigerant in the liquid state.)

## [11] Characteristics of the Conventional and the New Refrigerants

### 1. Chemical property

As with R22, refrigerants R410A and R134a are low in toxicity and chemically stable nonflammable refrigerants.

However, because the specific gravity of vapor refrigerant is greater than that of air, leaked refrigerant in a closed room will accumulate at the bottom of the room and may cause hypoxia.

If exposed to an open flame, refrigerant will generate poisonous gases. Do not perform installation or service work in a confined area.

	New Refrigerant (HFC type)	
	R410A	R134a
	R32/R125	R134a
Composition (wt%)	(50/50)	(100)
Type of Refrigerant	Pseudo-azeotropic Refrigerant	Single-Refrigerant
Chloride	Not included	Not contained
Safety Class	A1/A1	A1/A1
Molecular Weight	72.6	102.0
Boiling Point (°C/°F)	-51.4/-60.5	-26.1/-15.0
Steam Pressure (25°C, MPa/77°F, psi) (gauge)	1.557/226	0.67/97
Saturated Steam Density (25°C, kg/m <sup>3</sup> /77°F, psi)	64.0	32.3
Flammability	Nonflammable	Non-flammable
Ozone Depletion Coefficient (ODP) <sup>*1</sup>	0	0
Global Warming Coefficient (GWP) <sup>*2</sup>	1730	1300
Refrigerant Charging Method	Refrigerant charging in the liquid state	Liquid charging
Replenishment of Refrigerant after a Refrigerant Leak	Available	Possible

\*1 When CFC11 is used as a reference

\*2 When CO<sub>2</sub> is used as a reference

### 2. Refrigerant composition

R410A is a pseudo-azeotropic HFC blend and can almost be handled the same way as a single refrigerant, such as R22. To be safe, however, draw out the refrigerant from the cylinder in the liquid phase. If the refrigerant in the gaseous phase is drawn out, the composition of the remaining refrigerant will change and become unsuitable for use.

If the refrigerant leaks out, it may be replenished. The entire refrigerant does not need to be replaced.

### 3. Pressure characteristics

R410A has slightly higher operating pressure compared with R22.

Temperature (°C/°F)	Pressure (gauge)		
	R410A	R134a	R22
	MPa/psi	MPa/psi	MPa/psi
-20/-4	0.30/44	0.13/19	0.14/20
0/32	0.70/102	0.29/42	0.40/58
20/68	1.34/194	0.57/83	0.81/117
40/104	2.31/335	1.02/148	1.44/209
60/140	3.73/541	1.68/244	2.33/338
65/149	4.17/605	1.89/274	2.60/377

## [12] Notes on Refrigerating Machine Oil

### 1. Refrigerating machine oil in the HFC refrigerant system

HFC type refrigerants use a refrigerating machine oil different from that used in the R22 system. Note that the ester oil used in the system has properties that are different from commercially available ester oil.

Refrigerant	Refrigerating machine oil
R134a	HAB
R410A	Ester oil

### 2. Effects of contaminants\*1

Refrigerating machine oil used in the HFC system must be handled with special care to keep contaminants out. The table below shows the effect of contaminants in the refrigerating machine oil on the refrigeration cycle.

### 3. The effects of contaminants in the refrigerating machine oil on the refrigeration cycle.

Cause		Symptoms	Effects on the refrigerant cycle
Water infiltration		Frozen expansion valve and capillary tubes	Clogged expansion valve and capillary tubes Poor cooling performance Compressor overheat Motor insulation failure Burnt motor Coppering of the orbiting scroll Lock Burn-in on the orbiting scroll
		Hydrolysis Sludge formation and adhesion Acid generation Oxidization Oil degradation	
Air infiltration		Oxidization	
Infiltration of contaminants	Dust, dirt	Adhesion to expansion valve and capillary tubes	Clogged expansion valve, capillary tubes, and drier Poor cooling performance Compressor overheat
		Infiltration of contaminants into the compressor	Burn-in on the orbiting scroll
	Mineral oil etc.	Sludge formation and adhesion	Clogged expansion valve and capillary tubes Poor cooling performance Compressor overheat
		Oil degradation	Burn-in on the orbiting scroll

\*1. Contaminants is defined as moisture, air, processing oil, dust/dirt, wrong types of refrigerant, and refrigerating machine oil.

## 2 Restrictions

### [1] Types and Maximum allowable Length of Cables

#### 1. Wiring work

##### (1) Notes

- 1) Have all electrical work performed by an authorized electrician according to the local regulations and instructions in this manual.
- 2) Install external transmission cables at least 5cm [1-31/32"] away from the power supply cable to avoid noise interference. (Donot put the control cable and power supply cable in the same conduit tube.)
- 3) Provide grounding for the outdoor unit as required.
- 4) Run the cable from the electric box of the indoor or outdoor unit in such way that the box is accessible for servicing.
- 5) Do not connect power supply wiring to the terminal block for transmission line. Doing so will damage the electronic components on the terminal block.
- 6) Use 2-core shielded cables as transmission cables.

Use a separate 2-core control cable for each refrigerant system. Do not use a single multiple-core cable to connect indoor units that belong to different refrigerant systems. The use of a multiple-core cable may result in signal transmission errors and malfunctions.

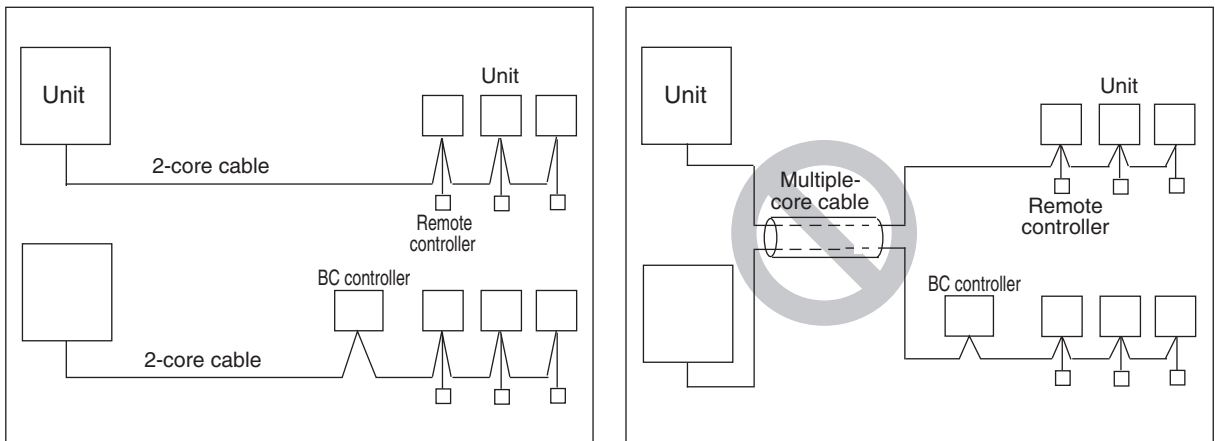

- 7) When extending the transmission cable, be sure to extend the shield wire.

#### (2) Control wiring

##### Types and maximum allowable length of cables

Control lines are categorized into 2 types: transmission line and remote controller line.

Use the appropriate type of cables and observe the maximum allowable length specified for a given system. If a given system has a long transmission line or if a noise source is located near the unit, place the unit away from the noise source to reduce noise interference.

PWFY-P100VM-E-BU

	Transmission cables	MA Remote controller cables	External input	External output
Type of cable	Shielding wire (2-core) CVVS, CPEVS or MVVS	Sheathed 2-core cable (shielded) CVVS	Sheathed multi-core cable (shielded) CVVS or MVVS	Sheathed multi-core cable (unshielded) CVV or MVV
Cable diameter	More than 1.25 mm <sup>2</sup>	0.3 ~ 1.25 mm <sup>2</sup> (0.75 ~ 1.25 mm <sup>2</sup> )*1	0.3 ~ 0.5 mm <sup>2</sup>	0.3 ~ 1.25 mm <sup>2</sup>
Remarks	-	Max.length: 200 m	Max.length: 100 m	Rated voltage: L1-N: 220 ~ 240 V Rated load: 0.6 A

PWFY-P100/200VM-E/E1/E2-AU

	Transmission cables	MA Remote controller cables	External input	External output
Type of cable	Shielding wire (2-core) CVVS, CPEVS or MVVS	Sheathed 2-core cable CVV (unshielded)	Sheathed multi-core cable CVV or MVV (unshielded)	Sheathed multi-core cable (unshielded) CVV or MVV
Cable diameter	More than 1.25 mm <sup>2</sup>	0.3 ~ 1.25 mm <sup>2</sup> (0.75 ~ 1.25 mm <sup>2</sup> )*1	0.3 ~ 0.5 mm <sup>2</sup>	0.3 ~ 1.25 mm <sup>2</sup>
Remarks	-	Max.length: 200 m	Max.length: 100 m	Rated voltage: L1-N: 220 ~ 240 V Rated load: 0.6 A

\*1 Connected with simple remote controller. CVVS, MVVS: PVC insulated PVC jacketed shielded control cable  
CVV, MVV : PVC insulated PVC sheathed control cable  
CPEVS : PE insulated PVC jacketed shielded communication cable

## [2] Types of Switch Setting and Address Setting

### 1. Switch setting

#### Type and method of switch setting

Switch setting vary depending on the system configuration. Make sure to read “[3] Examples of system connection” before conducting electrical work. Turn off the power before setting the switch. Operating the switch while the unit is being powered will not change the setting, and the unit will not properly function.

### 2. Address setting

(1) Address setting varies depending on the system configuration. See “[3] Examples of system connection” section for details.

Unit or controller		Address setting range	Setting method	Factory setting
Unit	Main/sub units	0, 01~50 (Note 1)	Assign the smallest address to the indoor unit to become the main unit within the same group, and then use sequential numbers to assign an address to all the indoor units in the group. If applicable, set the sub BC controllers in an R2 system in the following order: (1) Indoor unit to be connected to the main BC controller (2) Indoor unit to be connected to No.1 sub BC controller (3) Indoor unit to be connected to No.2 sub BC controller Set the address so that (1) < (2) < (3)	00
MA remote controller		No address setting required. (When operating with 2 remote controllers, the main/sub selector switch must be set.		Main
Outdoor unit		0, 51~100 (Note 1, 2, 3)	Use the address that equals the sum of the smallest indoor unit address in the same refrigerant system and 50.	00
Auxiliary units	BC controller (Main)	52~100 (Note 2, 3)	Use the address that equals the sum of the address of the heat source unit in the same refrigerant system and 1.	
	BC controller (Sub)		Use the address that equals the sum of the smallest address of the indoor unit out of all the indoor units that are connected to the BC controller and 50. When a sub BC controller is connected, the automatic start up function will not be available.	

Notes:

- Address setting is not required for a single refrigerant system (with a few exception).
- When setting the unit and outdoor auxiliary unit address to “100,” make it “50.”
- When an address in a system overlapped with the heat source unit or BC controller (Main) address of other refrigerant system, choose an another address within the set range that is not in use (with a few exceptions).
- BC controller is found only in the R2 systems.

(2) Unit port switch setting (R2 series (Factory Setting: “0”))

Make the settings for the port switch that corresponds to the connected BC (Main/Sub) controller.  
When more than two ports are used, make the setting on the port with a smaller port number.

(3) Various start-stop controls (Unit settings)

Each unit (or group of units) can be controlled individually by setting SW 1-3 and 1-4.

Function	Operation of the indoor unit when the operation is resumed after the unit was stopped	Setting (SW1) (Note 2)	
		3	4
Power ON/OFF by the plug (Note 1)	Unit will go into operation regardless of its operation status before power off (power failure). (In approx. 5 minutes)	OFF	ON
Automatic restoration after power failure	Unit will go into operation if it was in operation when the power was turned off (or cut off due to power failure). (In approx. 5 minutes)	ON	ON
	Unit will remain stopped regardless of its operation status before power off (power failure).	OFF	OFF

(Note 1) Do not cut off power to the outdoor unit.

Cutting off the power supply to the outdoor unit will cut off the power supply to the crankcase heater and may cause the compressor to malfunction when the unit is put back into operation.

(Note 2) Requires that the dipswitch settings for all the units in the group be made.

### [3] Examples of system connection

#### 1. Connecting remote controller, indoor and outdoor transmission cables

- Connect unit TB5 and outdoor unit TB3. (Non-polarized 2-wire (shield))  
The “S” on unit TB5 is a shielding wire connection. For specifications about the connecting cables, refer to the outdoor unit installation manual.
- Install a remote controller following the manual supplied with the remote controller.

#### 2. System using MA remote controller

(1) In the case of single refrigerant system (Automatic address set-up)

- Connect the “1” and “2” on unit TB15 to a MA remote controller. (Non-polarized 2-wire)  
MA Remote controller

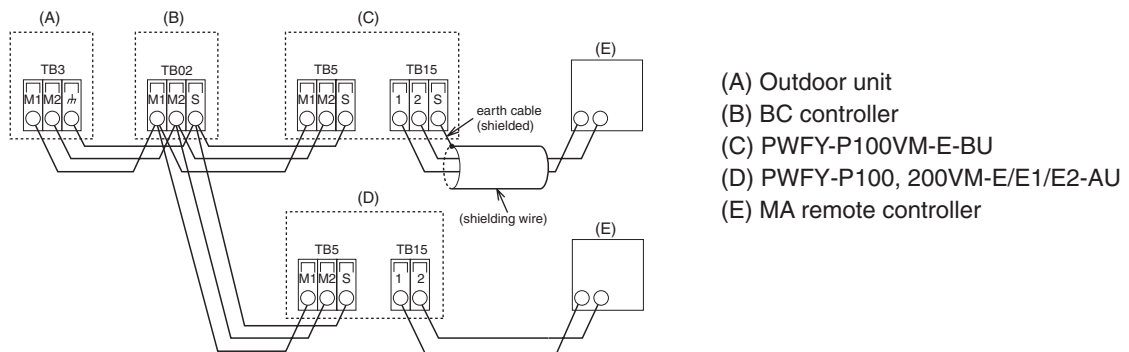

- DC 10 to 13 V between 1 and 2 (MA remote controller)

PWFY- P100VM-E-BU

PWFY- P100, 200VM-E/E1/E2-AU

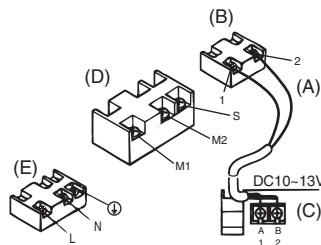
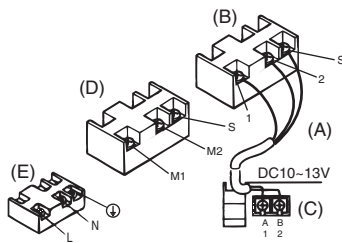

- (A) Non-polarized
- (B) TB15 (MA remote controller cables)
- (C) MA remote Controller
- (D) TB5 (Transmission cables)
- (E) TB2 (Power supply wiring)

- The MA remote controller cannot be used at the same time or interchangeably.

#### Note:

Ensure that the wiring is not pinched when fitting the terminal box cover. Pinching the wiring may cut it.

#### ⚠ Caution:

- Use wire with supplemental insulation.
- Input to TB142A, TB142B, and TB142C should not carry voltage.
- Cables from equipment connected to external input/output should have supplemental insulation.
- Use a single multiple-core cable for external input/output to allow for connection to the PG screw.

#### ⚠ Caution:

Wire the power supply so that no tension is imparted. Otherwise disconnection, heating or fire result.

#### [4] Restrictions on piping length

The same piping length restrictions apply as the ones that apply to the conventional indoor units. Refer to the Service Manual that came with the outdoor unit for restrictions on piping length.

Design the water piping system so that the total amount of water in the entire system will be as shown in the table below.

PWFY-P100VM-E-BU

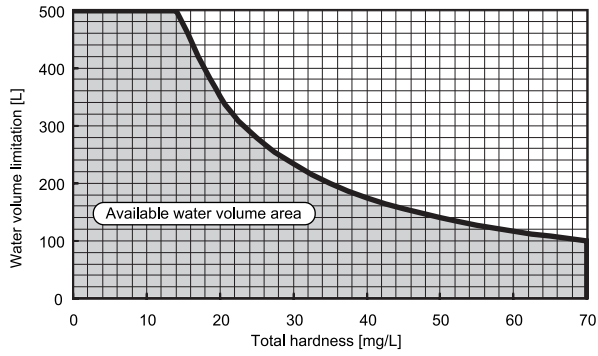

Condition: Water outlet temp. 70°C

PWFY-P100/200VM-E/E1/E2-AU

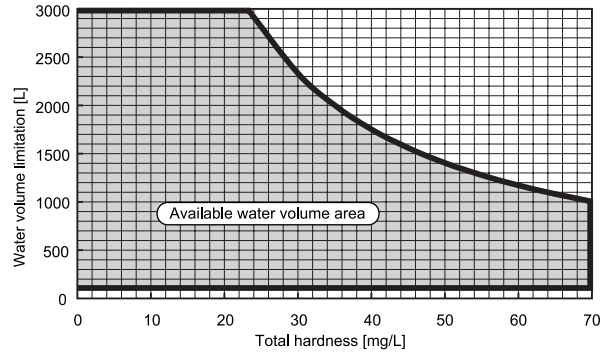

Condition: Water outlet temp. 45°C



### 3 Components of the Unit

#### [1] Appearance of the Components and Refrigerant Circuit

< PWFY-P100VM-E-BU >

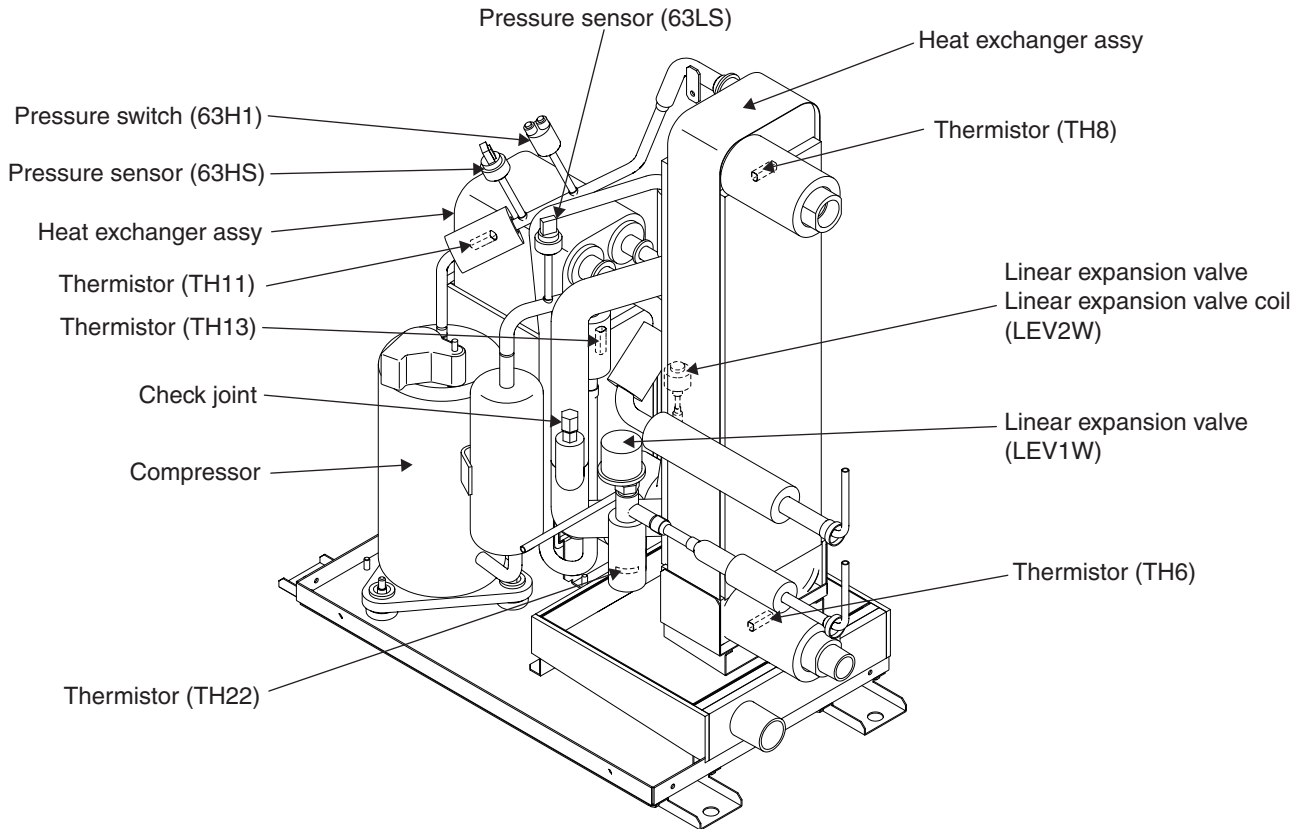

< PWFY-P100, 200VM-E/E1-AU >

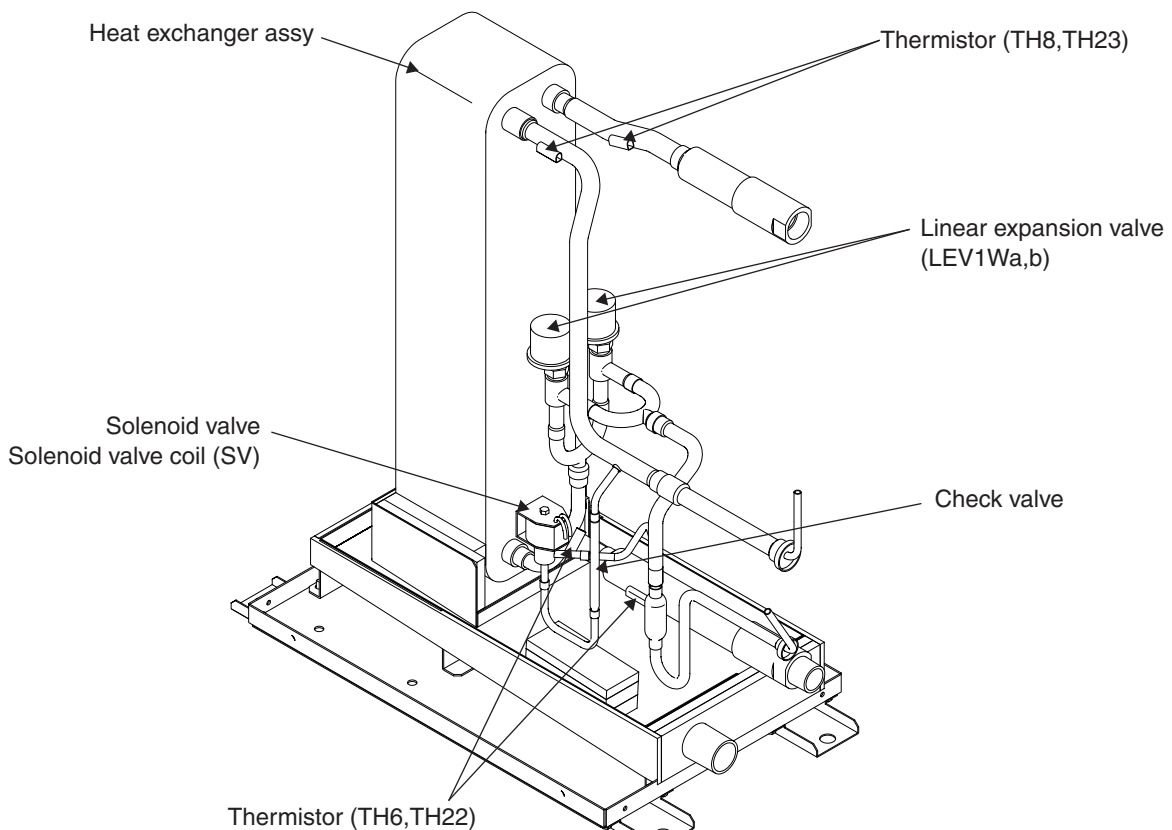

< PWFY-P100, 200VM-E2-AU >

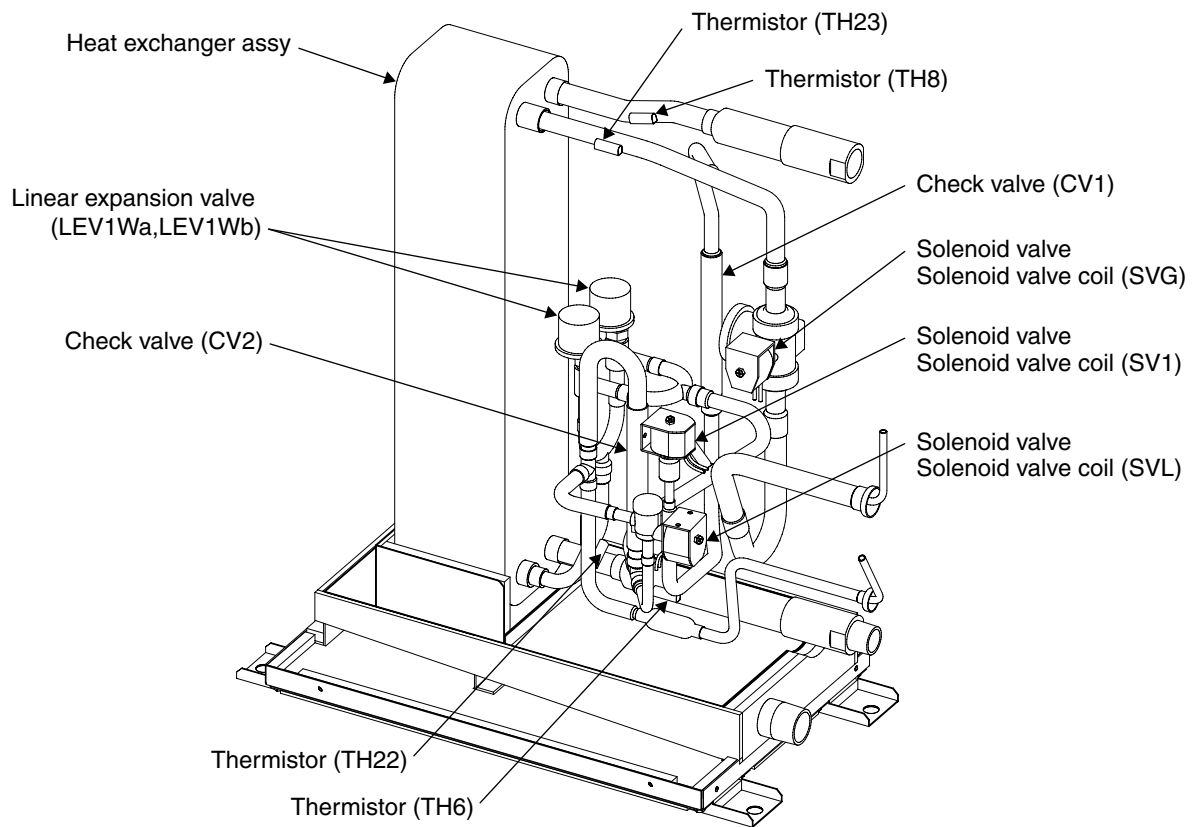

## [2] Control Box

< PWFY-P100VM-E-BU >

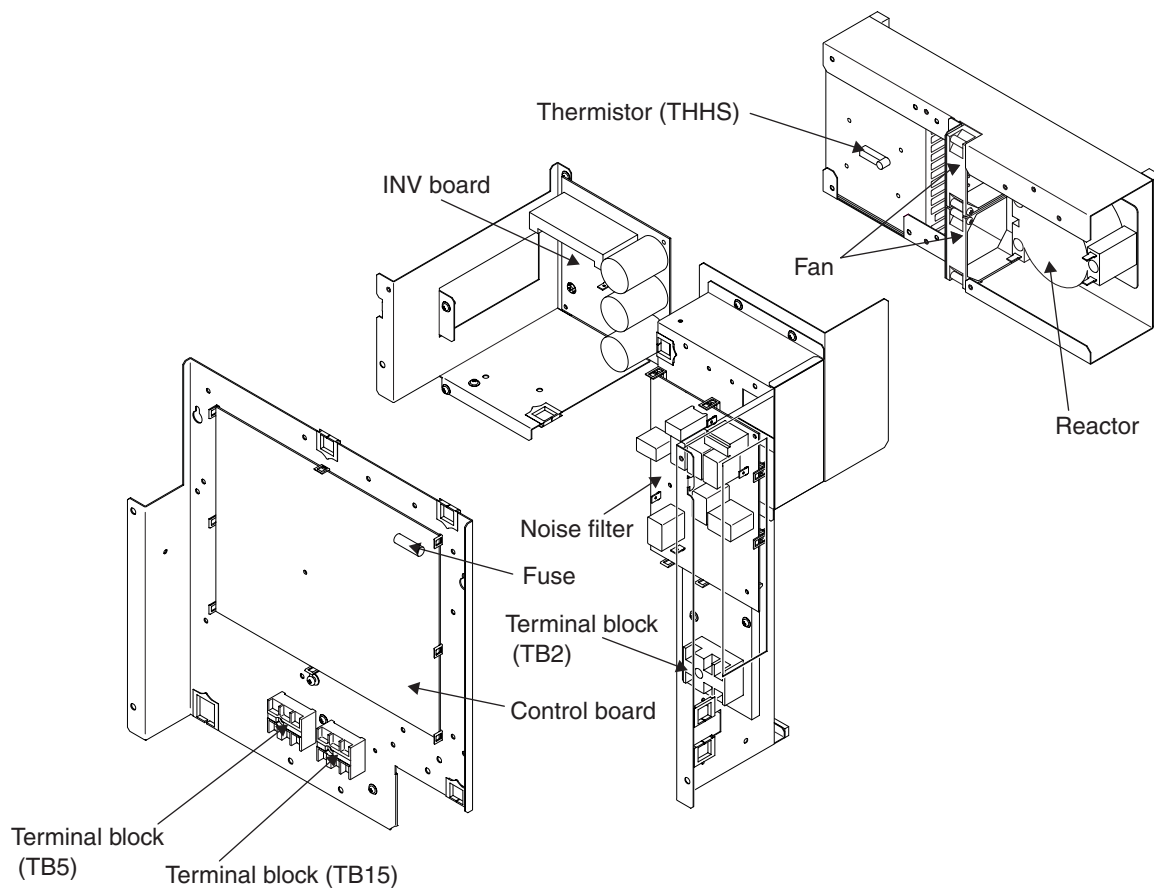

< PWFY-P100, 200VM-E/E1-AU >

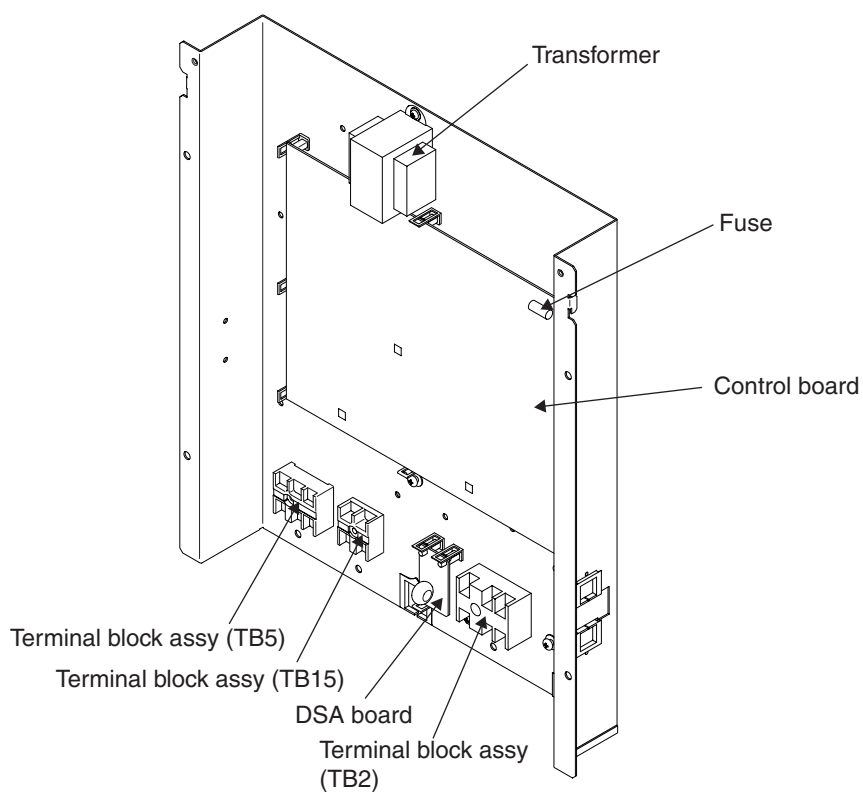

< PWFY-P100, 200VM-E2-AU >

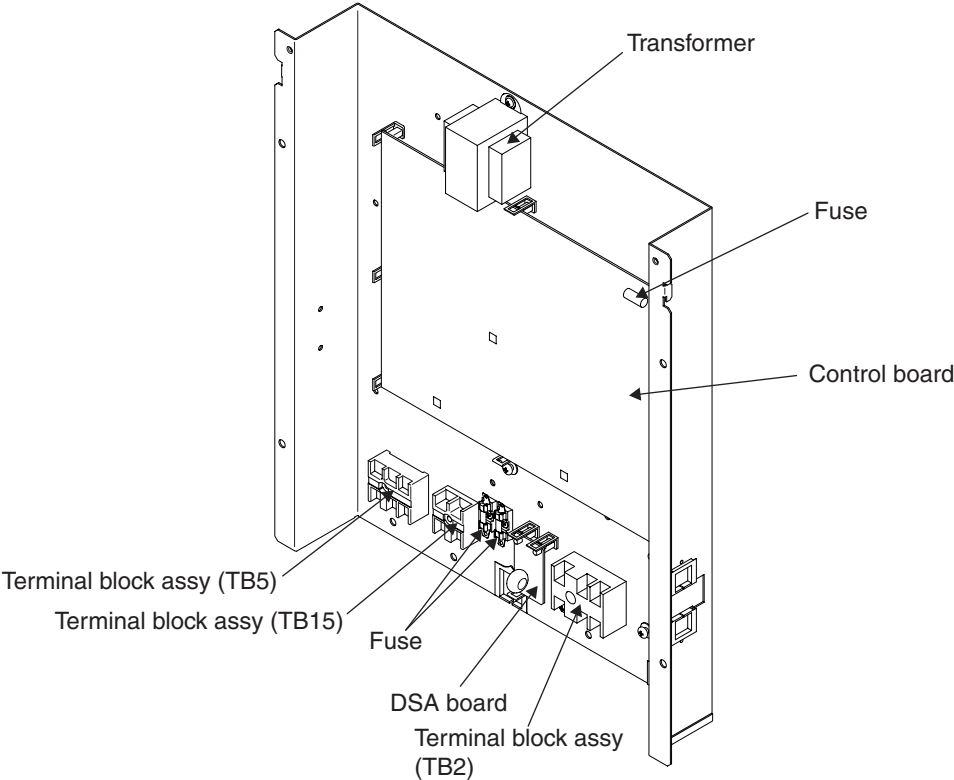



## 2. Power board

< PWFY-P100VM-E-BU >

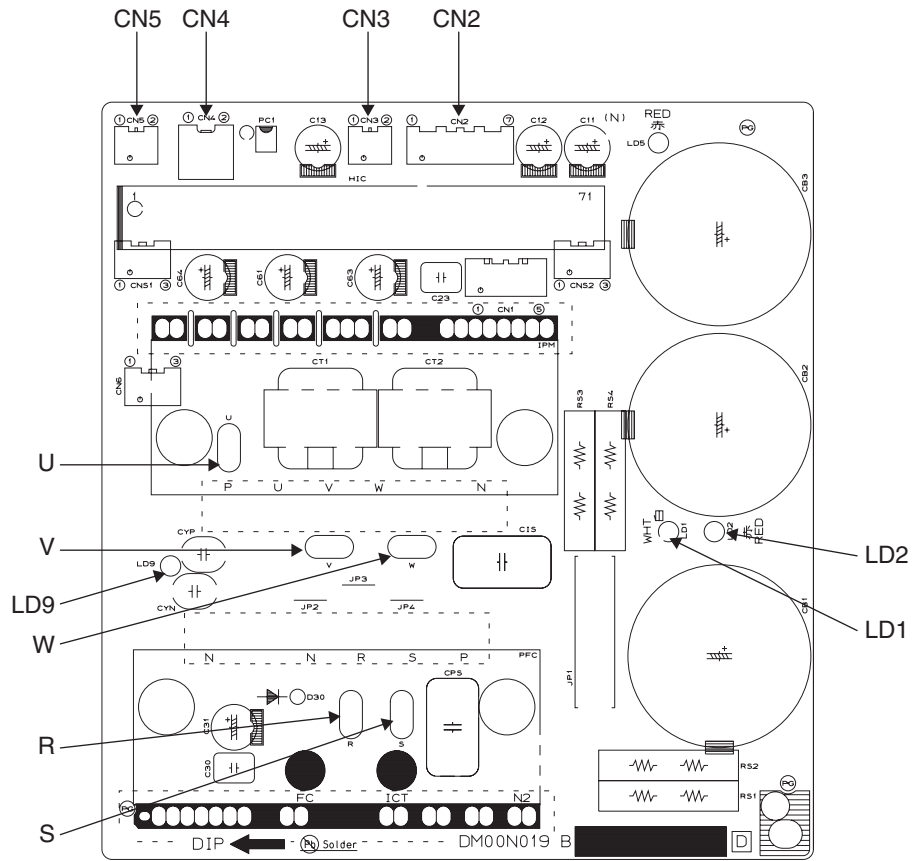

### 3. Noise filter

< PWFY-P100VM-E-BU >

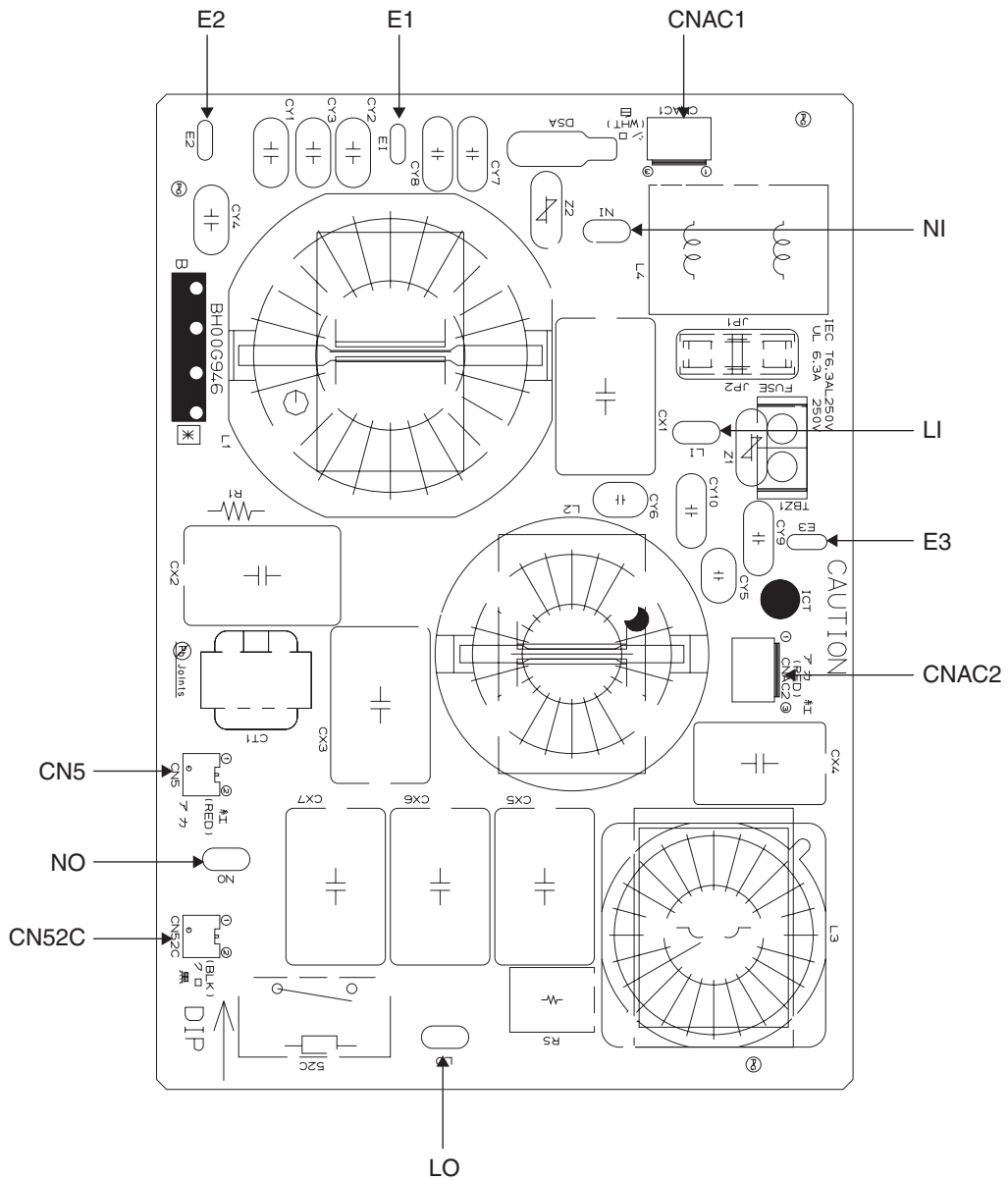

### 4. DSA

< PWFY-P100,200VM-E-AU, PWFY-P100,200VM-E1-AU, PWFY-P100,200VM-E2-AU >

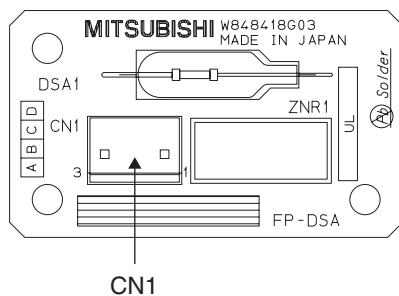

## 4 Remote Controller

### [1] Functions and Specifications of MA Remote Controller

MA remote controller is connected to each unit.

Function/specification	MA remote controller
Remote controller address setting	Not required
Indoor/outdoor unit address setting	Not required (required only by a system with one outdoor unit)
Wiring method	Non-polar 2 wires ※ Daisy-chain the units with non-polar 2 wires when running a group operation.
Installation location of remote controller	Connectable to any unit in the group
Making group changes	MA remote controller wires between units require rewiring.



## [2] Interlocking Setting via the MA Remote Controller

### 1. Remote controller function selection via the MA remote controller

#### Function selection of remote controller

The setting of the following remote controller functions can be changed using the remote controller function selection mode. Change the setting when needed.

Item 1	Item 2	Item 3 (Setting content)
1. Change Language ("CHANGE LANGUAGE")	Language setting to display	<ul style="list-style-type: none"> <li>Display in multiple languages is possible</li> </ul>
2. Function limit ("FUNCTION SELECTION")	(1) Operation function limit setting (operation lock) ("LOCKING FUNCTION")	<ul style="list-style-type: none"> <li>Setting the range of operation limit (operation lock)</li> </ul>
	(2) Operation mode skip setting ("SELECT MODE")	<ul style="list-style-type: none"> <li>Setting the use or non-use of each operation mode</li> </ul>
	(3) Temperature range limit setting ("LIMIT TEMP FUNCTION")	<ul style="list-style-type: none"> <li>Setting the temperature adjustable range (maximum, minimum)</li> </ul>
3. Mode selection ("MODE SELECTION")	(1) Remote controller main/sub setting ("CONTROLLER MAIN/SUB")	<ul style="list-style-type: none"> <li>Selecting main or sub remote controller</li> <li>* When two remote controllers are connected to one group, one controller must be set to sub.</li> </ul>
	(2) Use of clock setting ("CLOCK")	<ul style="list-style-type: none"> <li>Setting the use or non-use of clock function</li> </ul>
	(3) Timer function setting ("WEEKLY TIMER")	<ul style="list-style-type: none"> <li>Setting the timer type</li> </ul>
	(4) Contact number setting for error situation ("CALL.")	<ul style="list-style-type: none"> <li>Contact number display in case of error</li> <li>Setting the telephone number</li> </ul>
	(5) Temp off set setting ("TEMP OFF SET FUNCTION")	<ul style="list-style-type: none"> <li>Setting the use or non-use of setback amount setting</li> </ul>
4. Display change ("DISP MODE SETTING")	(1) Temperature display °C/°F setting ("TEMP MODE °C/°F")	<ul style="list-style-type: none"> <li>Setting the temperature unit (°C or °F) to display</li> </ul>
	(2) Water temperature display setting ("WATER TEMP DISP SELECT")	<ul style="list-style-type: none"> <li>Setting the use or non-use of the display of water temperature</li> </ul>

#### Function selection flowchart

[1] Stop the unit to start remote controller function selection mode. → [2] Select from item 1. → [3] Select from item 2. → [4] Make the setting. (Details are specified in item 3) → [5] Setting completed. → [6] Change the display to the normal one. (End)

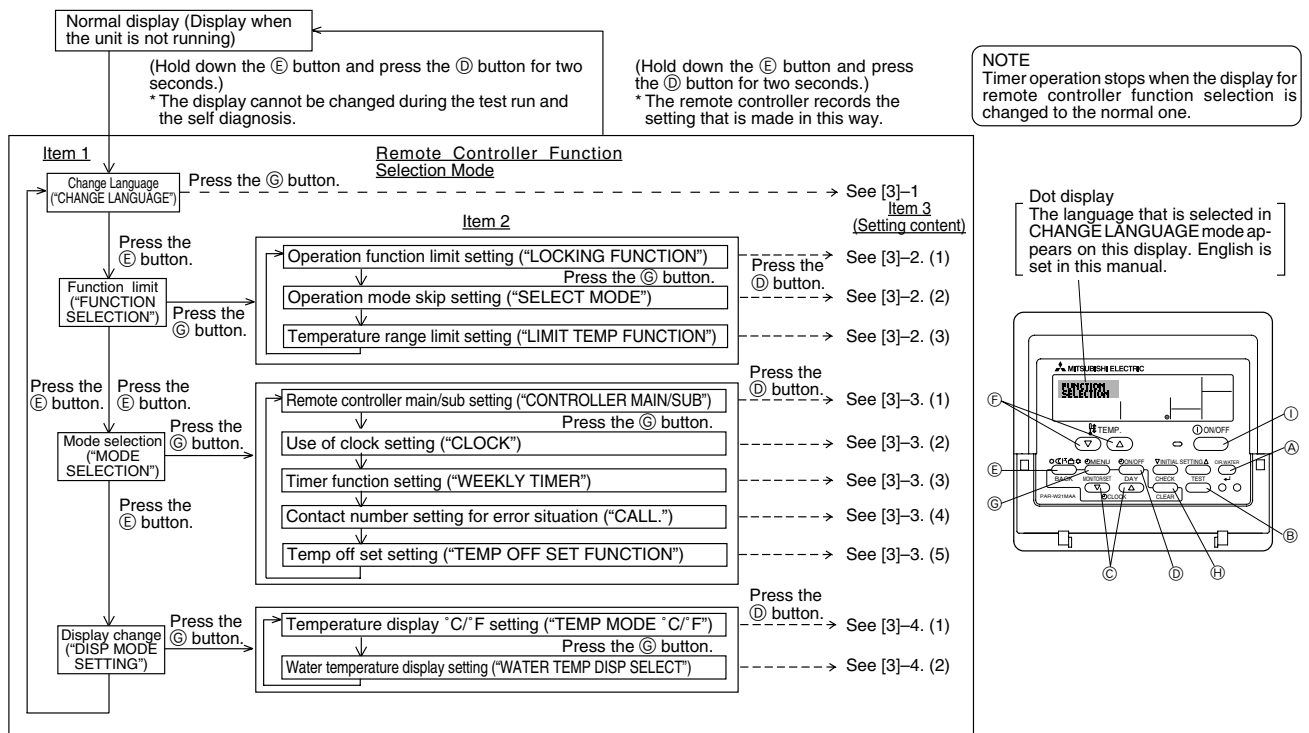

## Detailed setting

### [3]-1. CHANGE LANGUAGE setting

The language that appears on the dot display can be selected.

- Press the [MENU] button to change the language.
  - ① English (GB), ② German (D), ③ Spanish (E), ④ Russian (RU),
  - ⑤ Italian (I), ⑥ French (F), ⑦ Swedish

### [3]-2. Function limit

#### (1) Operation function limit setting (operation lock)

- To switch the setting, press the [ON/OFF] button.
  - ① no1 : Operation lock setting is made on all buttons other than the [ON/OFF] button.
  - ② no2 : Operation lock setting is made on all buttons.
  - ③ OFF (Initial setting value) : Operation lock setting is not made.
- \* To make the operation lock setting valid on the normal screen, it is necessary to press buttons (Press and hold down the [CIR. WATER] and [ON/OFF] buttons at the same time for two seconds.) on the normal screen after the above setting is made.

#### (2) Operation mode skip setting

After setting is changed, the operation mode can not be changed within the changed range.

- To switch the following settings, press the [ON/OFF] button.
  - ① Heating mode : Sets the use or non-use of the Heating mode.
  - ② Heating ECO mode : Sets the use or non-use of the Heating ECO mode.
  - ③ Hot Water mode : Sets the use or non-use of the Hot Water mode.
  - ④ Anti-freeze mode : Sets the use or non-use of the Anti-freeze mode.
  - ⑤ Cooling mode : Sets the use or non-use of the Cooling mode.
  - ⑥ OFF (Initial setting value) : Operation mode skip is not executed.
- \* When the setting, other than OFF, is made, the skip settings of the Heating, Heating ECO, Hot Water, Anti-freeze, and Cooling modes are executed at the same time.
- \* A mode that is not available on the unit to connect cannot be used even if the setting is "AVAILABLE."

#### (3) Temperature range limit setting

After this setting is made, the temperature can be changed within the set range.

- To switch the setting, press the [ON/OFF] button.
  - ① LIMIT TEMP HEATING MODE:  
The temperature range can be changed on heating mode.
  - ② LIMIT TEMP HOT WATER MODE:  
The temperature range can be changed on heating/hot water mode.
  - ③ LIMIT TEMP ANTI-FREEZE MODE:  
The temperature range can be changed on anti-freeze mode.
  - ④ LIMIT TEMP COOLING MODE:  
The temperature range can be changed on cooling mode.
  - ⑤ OFF (Initial setting) : The temperature range limit is not active.
- \* When the setting, other than OFF, is made, the temperature range limit setting on hot water, anti-freeze and cooling mode is made at the same time. However, the range cannot be limited when the set temperature range has not changed.
- To increase or decrease the temperature, press the [TEMP. (V) or (A)] button.
- Settable range

Hot Water mode	: Lower limit: 30 ~ 70 °C (87 ~ 158 °F)
	Upper limit: 70 ~ 30 °C (158 ~ 87 °F)
Heating mode	: Lower limit: 30 ~ 45 °C (87 ~ 113 °F)
	Upper limit: 45 ~ 30 °C (113 ~ 87 °F)
Cooling mode	: Lower limit: 10 ~ 30 °C (50 ~ 87 °F)
	Upper limit: 30 ~ 10 °C (87 ~ 50 °F)
- \* The settable range varies depending on the unit to connect.

### [3]-3. Mode selection setting

#### (1) Remote controller main/sub setting

- To switch the setting, press the [ON/OFF] button ⑩.
  - ① Main : The controller will be the main controller.
  - ② Sub : The controller will be the sub controller.

#### (2) Use of clock setting

- To switch the setting, press the [ON/OFF] button ⑩.
  - ① ON : The clock function can be used.
  - ② OFF : The clock function cannot be used.

#### (3) Timer function setting

- To switch the setting, press the [ON/OFF] button ⑩ (Choose one of the followings.).
  - ① WEEKLY TIMER (Initial setting value): The weekly timer can be used.
  - ② AUTO OFF TIMER : The auto off timer can be used.
  - ③ SIMPLE TIMER : The simple timer can be used.
  - ④ TIMER MODE OFF : The timer mode cannot be used.
- \* When the use of clock setting is OFF, the "WEEKLY TIMER" cannot be used.

#### (4) Contact number setting for error situation

- To switch the setting, press the [ON/OFF] button ⑩.
  - ① CALL OFF : The set contact numbers are not displayed in case of error.
  - ② CALL \*\*\*\*\* : The set contact numbers are displayed in case of error.  
CALL\_ : The contact number can be set when the display is as shown on the left.
- Setting the contact numbers  
To set the contact numbers, follow the following procedures.  
Move the flashing cursor to set numbers. Press the [TEMP. (V) or (A)] button (E) to move the cursor to the right (left). Press the [CLOCK (V) or (A)] button (C) to set the numbers.

#### (5) Temp off set setting

- To switch the following settings, press the [ON/OFF] button ⑩.
  - ① ON : The setback amount setting is displayed under the water temperature initial setting mode.
  - ② OFF : The setback amount setting is not displayed under the water temperature initial setting mode.

### [3]-4. Display change setting

#### (1) Temperature display °C/°F setting

- To switch the setting, press the [ON/OFF] button ⑩.
  - ① °C: The temperature unit °C is used.
  - ② °F: The temperature unit °F is used.

#### (2) Water temperature display setting

- To switch the setting, press the [ON/OFF] button ⑩.
  - ① ON : The water temperature is displayed.
  - ② OFF : The water temperature is not displayed.

# 5 Electrical Wiring Diagram

## [1] PWFY-P100VM-E-BU

- <HIGH VOLTAGE WARNING>  
 • Control box houses high-voltage parts.  
 • Before inspecting the inside of the control box, turn off the power, keep the unit off for at least 10 minutes and confirm that the voltage CNE61 on Control Board has dropped to DC20V or less.  
 <CAUTION FOR INSTALLATION>  
 • Prior to installation, read the Installation Manual carefully.  
 \*1. Single-dotted lines indicate wiring not supplied with the unit.  
 \*2. Dot-dash lines indicate the control box boundaries.  
 \*3. Faston terminals have a locking function.  
 Make sure the terminals are securely locked in place after insertion.  
 Press the tab on the terminals to removed them.

\*4 TB1 41A(output)

Symbol	Function
OUT1	Operation ON/OFF
OUT2	Defrost
OUT3	Compressor
OUT4	Error signal

\*5 TB1 42A(input)

Symbol	Function
IN1	Pump interlock

\*6 TB1 42B(input)

Symbol	Function
IN3	Connection demand
IN4	Operation ON/OFF

\*7 TB1 42C(input)

Symbol	Function
COM+	Common
IN5	Hot water
IN6	Heating ECO
IN7	Anti-freeze

<Symbol explanation>

Symbol	Explanation
63H1	High pressure switch (High pressure protection for the booster unit)
63HS	Pressure switch
63LS	Pressure sensor
52C	Magnetic relay(main circuit)
ACL	AC reactor
CT1/CT2	Current sensor(AC)
LEV2W	Expansion valve
BC	BC controller/outdoor unit booster unit
TB2	
TS5	Power supply
TH15	Outdoor unit/BC controller MA remote controller
TH11	Compressor discharge temp
TH13	Evaporator outlet temp
TH2	liquid pipe temp
TH6	water inlet temp
TH8	water outlet temp
TH9	water inlet temp
TH18	water outlet temp
TH19	water inlet temp
TH19S	water outlet temp

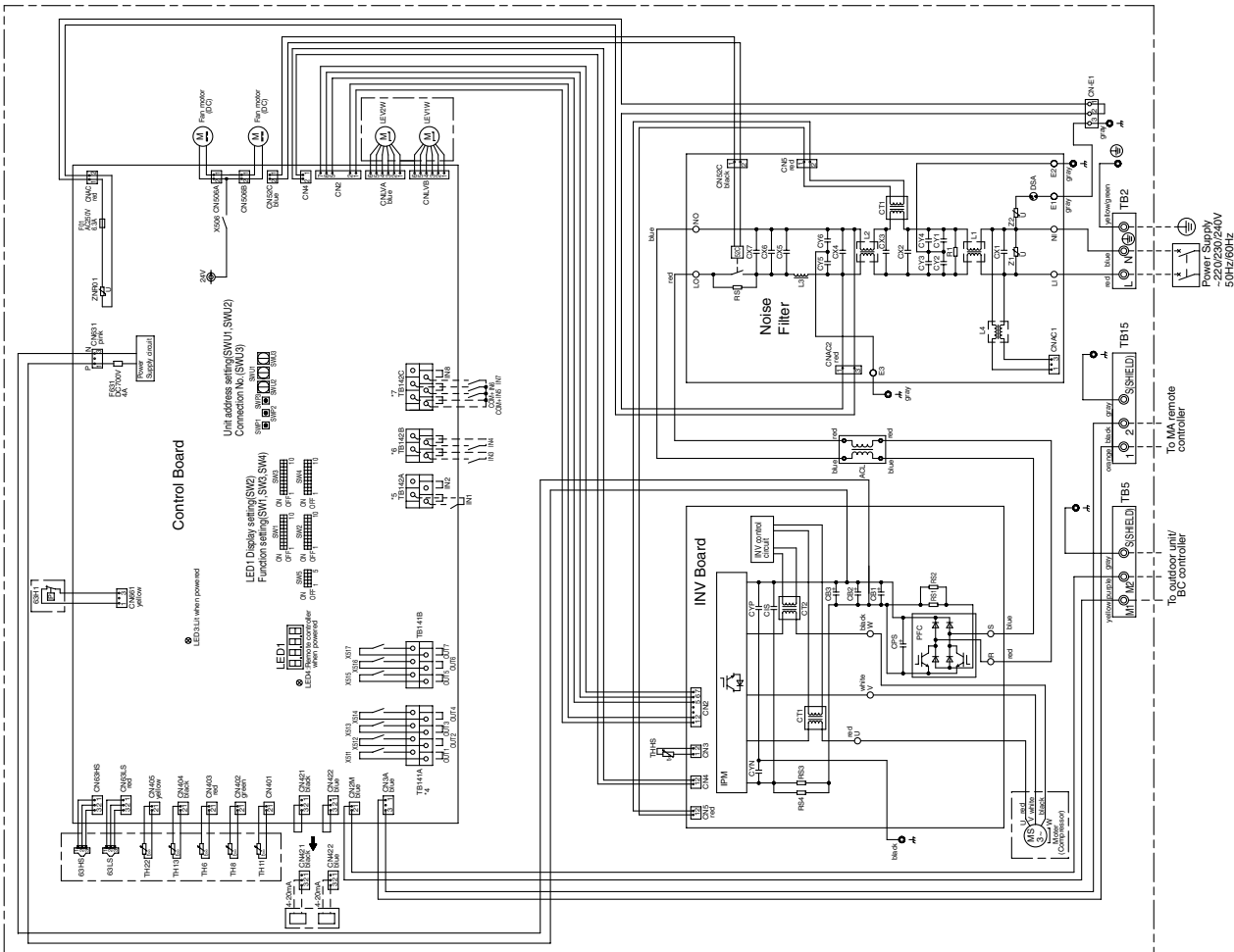

[2] PWFY-P100, 200VM-E-AU, PWFY-P100, 200VM-E1-AU

<CAUTION FOR INSTALLATION>

- Prior to installation, read the Installation Manual carefully.
- \*1. Single-dotted lines indicate wiring not supplied with the unit.
- \*2. Dot-dash lines indicate the control box boundaries.
- \*3. Difference of appliance

Model name	Appliance
F-600	3.00 not exist
F-200	1.3 exist

\*4 TB141A(output)

Symbol	Function
OUT1	Operation ON/OFF
OUT2	Defrost
OUT4	Error signal

\*5 TB142A(input)

Symbol	Function
IN1	Flow switch

\*6 TB142B(input)

Symbol	Function
IN3	Connection demand
IN4	Operation ON/OFF

\*7 TB142C(input)

Symbol	Function
COM+	Common
IN5	Heating
IN6	Heating ECO
IN7	Anti-freeze
IN8	Cooling

<Symbol explanation>

Symbol	Explanation
SW1	Subboard valve
SW2	Subboard valve
LEV1/W1	Expansion valve
LEV1/W1	Expansion valve
LEV1/W1	Expansion valve
TB2	Terminal block
TB5	Terminal block
TB15	Terminal block
TH23	Thermistor
TH2	Thermistor
TH6	Thermistor
TH8	Thermistor

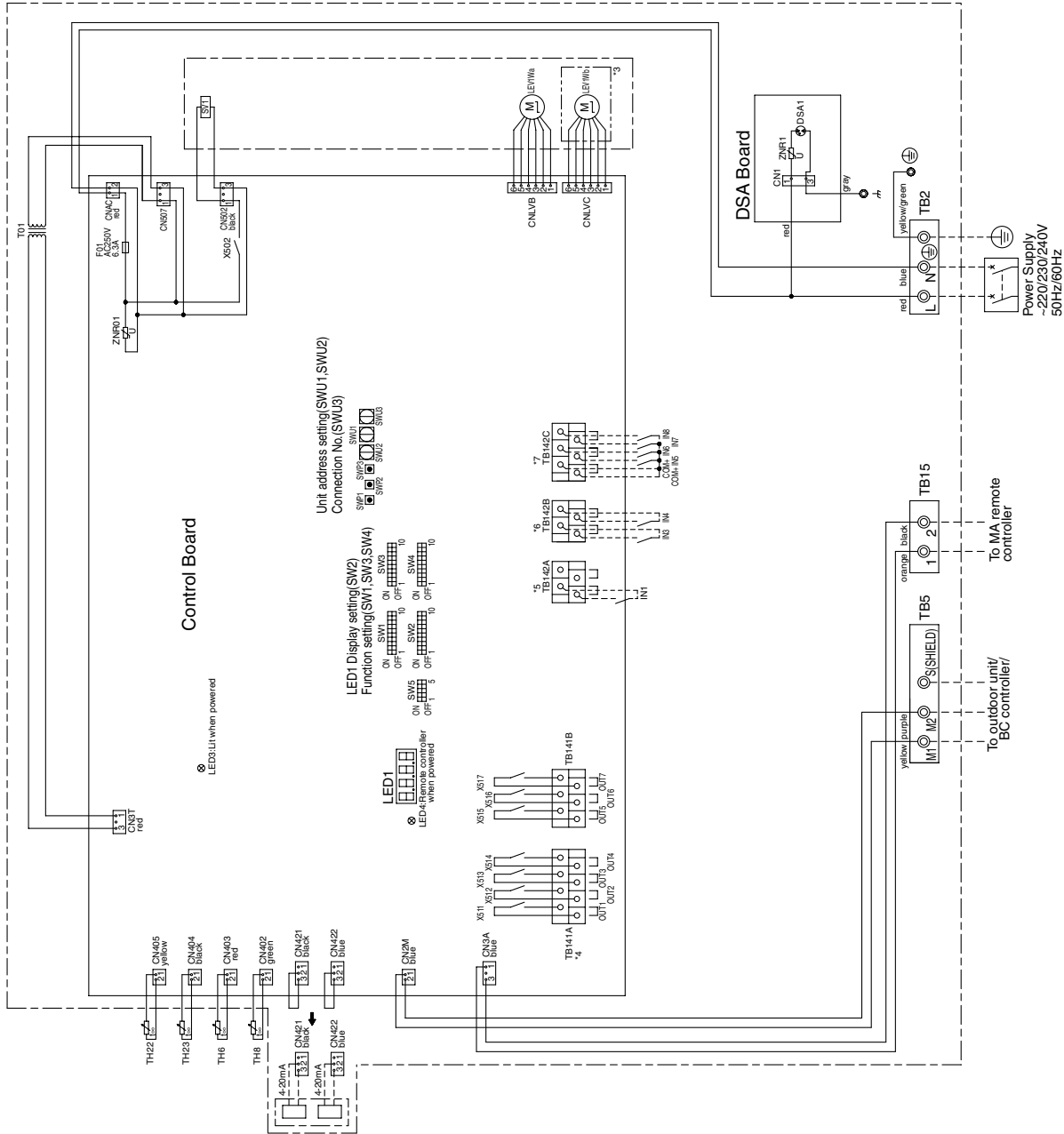

# [3] PWFY-P100, 200VM-E2-AU

**<CAUTION FOR INSTALLATION>**  
 -Prior to installation, read the installation Manual carefully.  
 \*1. Single-dotted lines indicate wiring not supplied with the unit.  
 \*2. Dot-dash lines indicate the control box boundaries.  
 \*3. Difference of appliance

Model Name	Appliance
P100	1~2 exist
P200	1~3 exist

### \*4 TB141A(output)

Symbol	Function
OUT1	Operation ON/OFF (Voltage contact)
OUT2	Demand
OUT4	Error signal
OUT3	is no function.

### \*5 TB142A(input)

Symbol	Function
INI	Flow switch

### \*6 TB142B(input)

Symbol	Function
INS	Connection demand
IN4	Operation ON/OFF

### \*7 TB142C(input)

Symbol	Function
COM+	Common
INS	Heating
INZ	Heating ECO
INZ	Freeze
INS	Cooling

### <Symbol explanation>

Symbol	Explanation
SV1	Solenoid valve
SVG	For opening/closing the bypass circuit
SVL	For opening/closing the gas refrigerant circuit
SVM	For opening/closing the liquid refrigerant circuit
LEV1WA	Linear expansion valve
LEV1WB	BC controller/outdoor unit
TB2	Terminal block
TB5	Outdoor unit/BC controller
TP15	Power supply
TP25	MA remote controller
TH5	liquid pipe temp sensor
TH6	water inlet temp sensor
TH8	water outlet temp sensor

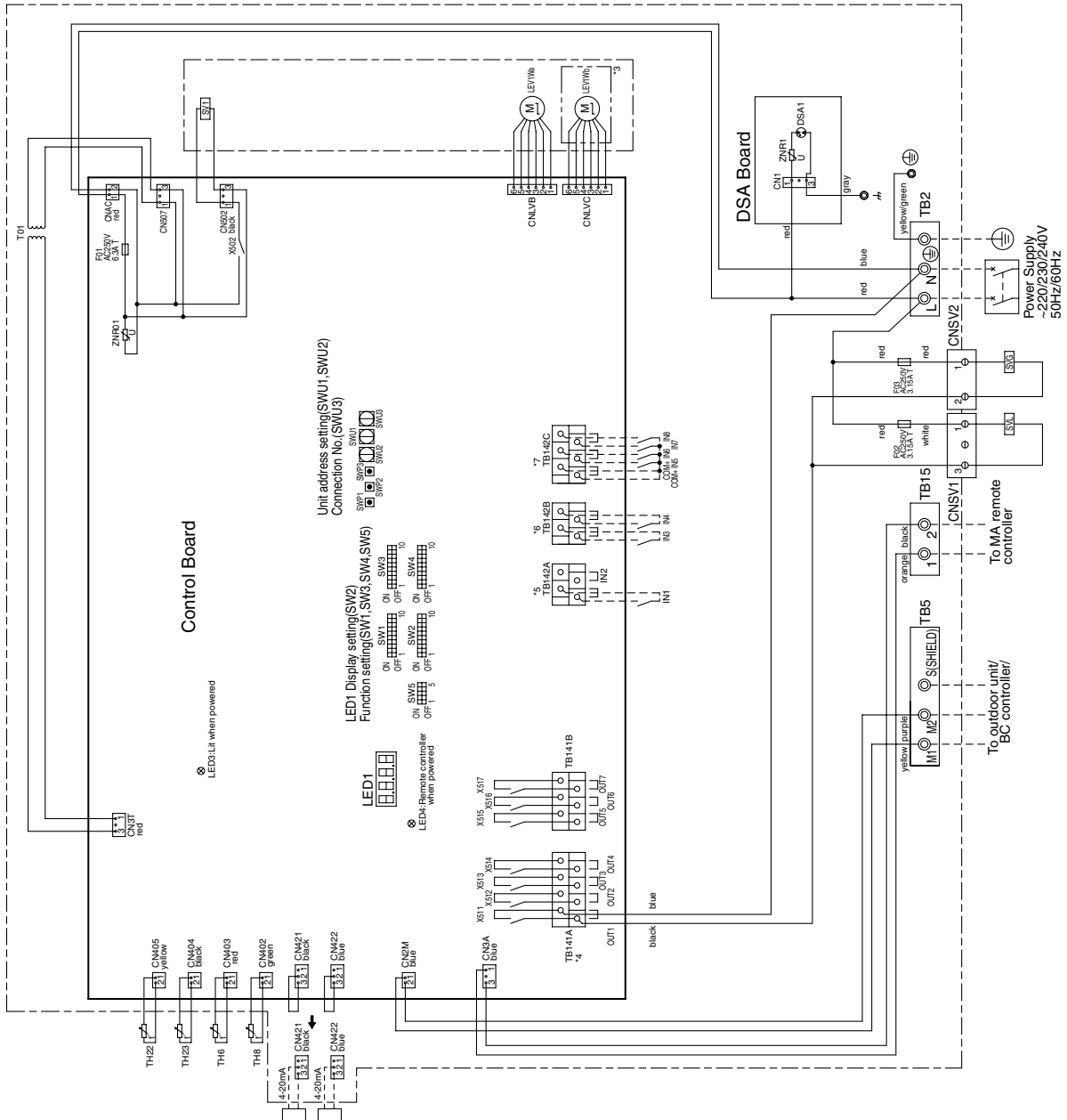

## 6 Refrigerant Circuit

### [1] Refrigerant Circuit Diagram

#### < PWFY-P100VM-E-BU >

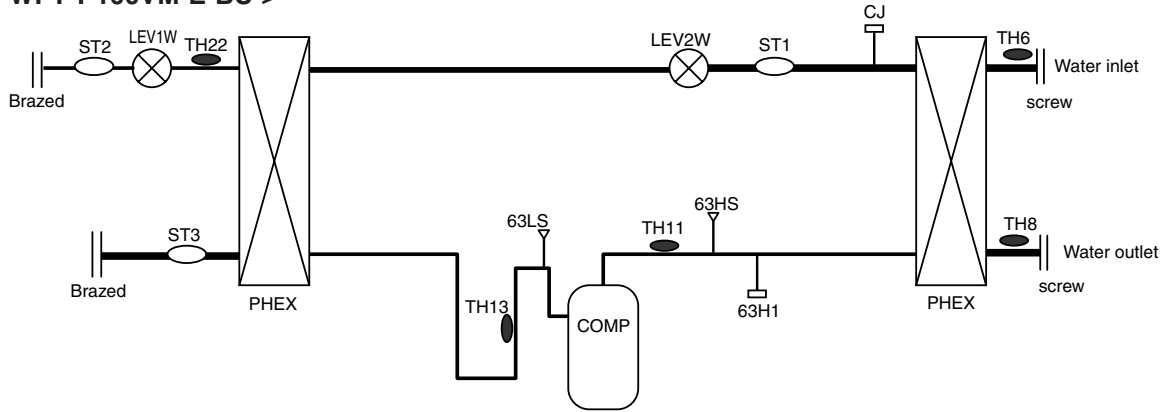

#### < PWFY-P100VM-E-AU, PWFY-P100VM-E1-AU >

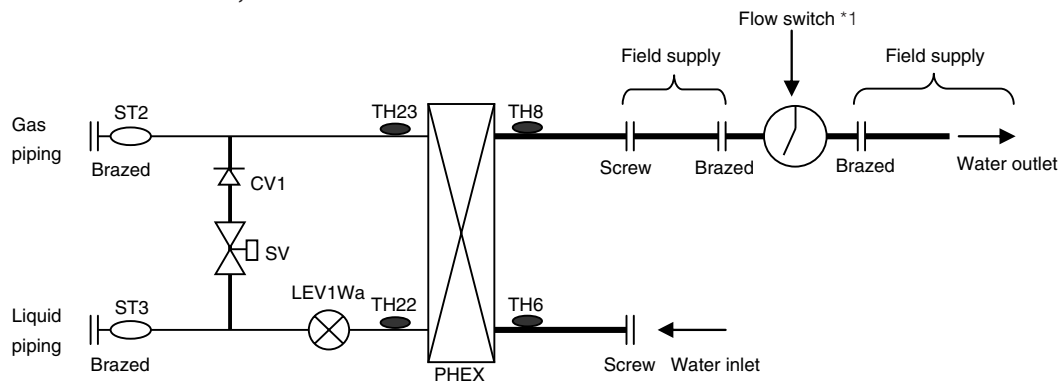

\*1 A flow switch is not supplied with PWFY-P100VM-E-AU. Please therefore supply it by yourself.

#### < PWFY-P200VM-E-AU, PWFY-P200VM-E1-AU >

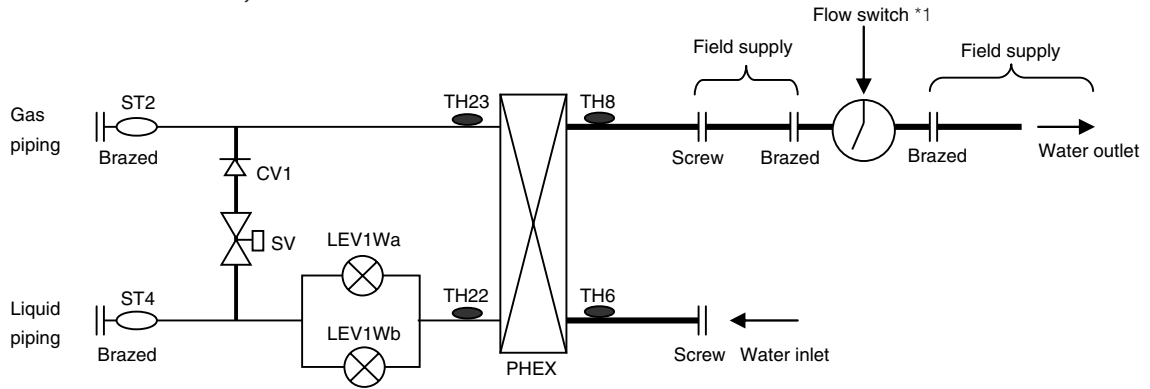

\*1 A flow switch is not supplied with PWFY-P200VM-E-AU. Please therefore supply it by yourself.

< PWFY-P100VM-E2-AU >

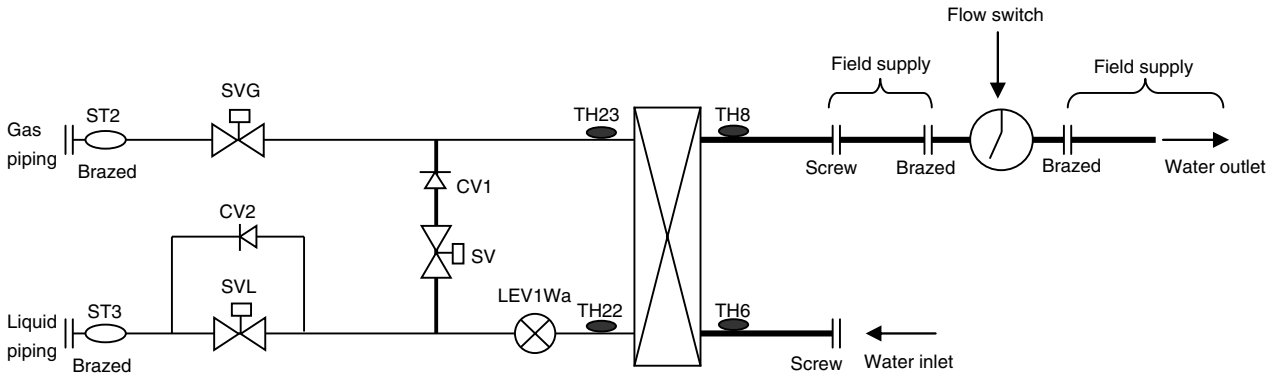

< PWFY-P200VM-E2-AU >

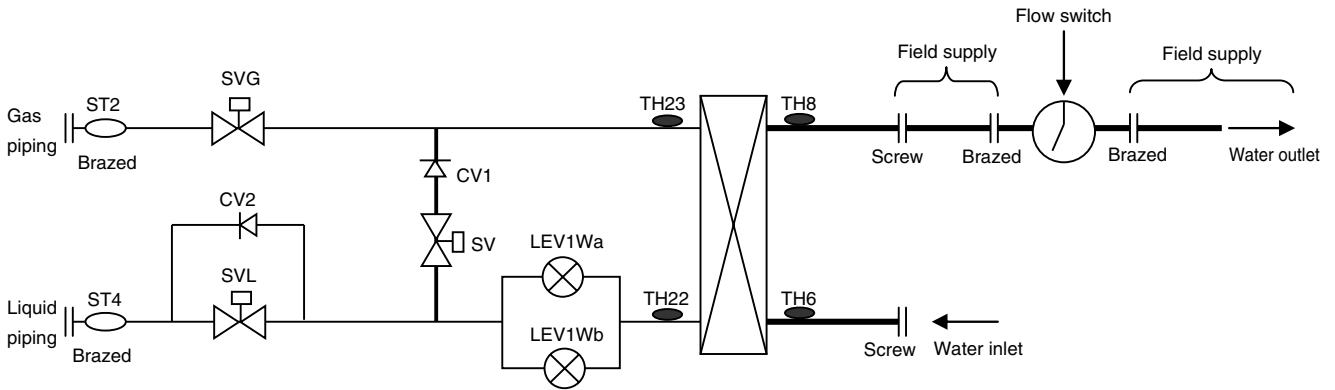

[2] Pump interlock

To perform test run before the pump interlock circuit is completed, short circuit the terminal block TB142A (IN1), and then perform test run. The unit may become damaged if it is operated with no water circulating through the pipes.

<PWFY-P100VM-E-BU>

Be sure to interlock unit operation and the water-circuit pump. Use the terminal blocks for interlocking TB142A (IN1) that can be found on the unit.

[Fig. A]

<PWFY-P100/200VM-E/E1/E2-AU>

When installing the unit, be sure to install the supplied flow switch on the water outlet side of the unit and connect the wire to IN1 of TB142A on the unit.

**If the flow switch is not installed, the unit will emit the error signal (2100: Interlock error) and not operate.**

\* A short-circuit wire is packaged supplied, but it is only for test run.

<Installation procedures>

- 1 Remove the pipes attached to the flow switch.  
**Note: The unit is shipped with the pipes loosely tightened.**
- 2 Wrap seal tape around the threads at the end of the pipes, starting at the 1.5th or 2nd thread, and not over the openings. Apply two to three wraps in the direction of the pipe threads (clockwise). Each course of the tape should overlap the one before it by 2/3 to 3/4 the width of the tape. Run your fingers around the threads and tape to press the tape into the threads.  
**Then, attach the pipes to the flow switch, holding parts A and B (Fig.C) with a spanner. The maximum tightening torque is 60 N•m (611 kgf•cm).**
- 3 Attach the flow switch and pipes to the water outlet in the horizontal position.

**The angle of the axis of the pipe should be less than 45 degrees.**

**Check the direction of the flow switch as shown in Fig. C.**

- 4 Connect the flow switch wire to IN1 of TB142A.

In the system including PWFY-P100/P200VM-E/E1/E2-AU, the circulating water may freeze, and result in a unit malfunction. Perform the electrical work as shown in [Fig. B] to prevent water from freezing.

Set the DipSW as shown in the table below.

DipSW3-6	External output contact
ON	Effective when Thermo-ON
OFF	Effective when Operation-ON (Remote controller-ON)

Be sure to turn on the power supply of the pump, since the control does not work if the power supply of the pump is turned off.

<PAC-SV01PW-E> \*PWFY-P100/P200VM-E/E1 ONLY

Implement the following for a PWFY-P100/P200VM-E/E1-AU unit that meets conditions (1) and (2) below:

- Pump interlock
- Use of a solenoid valve kit (PAC-SV01PW-E)

Conditions

- (1) When Y, Zubadan, WY, or Replace-Y series models are used for the outdoor units
- (2) When PWFY-P100/P200VM-E/E1-AU units are used for heating only and are placed on the same refrigerant circuit as the indoor units or other PWFY-P100/P200VM-E/E1/E2-AU units

However, this does not apply in cases where brine is added to the water line or cases where the unit is run in heating mode only as a refrigerant circuit system. Set Dip SW3-6 to ON. Make sure the version of the software is 1.18 or later.

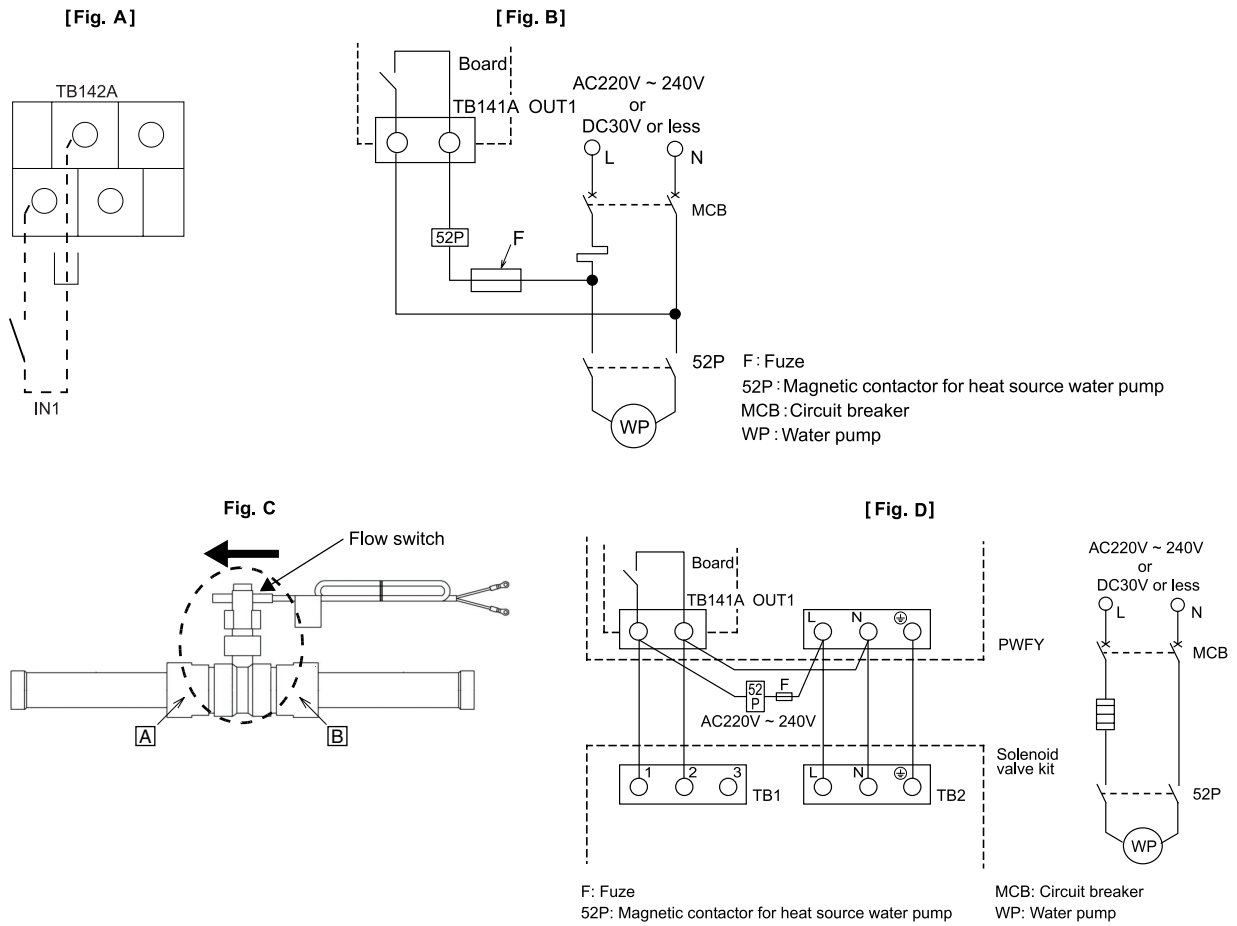

### [3] Functions of Principal Parts

#### 1. Unit

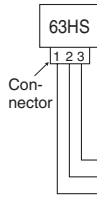
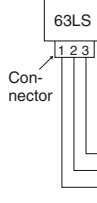
Part Name	Symbols (functions)	Notes	Usage	Specifications	Check method
Compressor	MC1		Adjusts the amount of circulating refrigerant by adjusting the operating frequency based on the operating pressure data	High-pressure shell rotary compressor 20°C[68°F] : 0.583Ω	
High-pressure sensor	63HS		1) Detects high pressure 2) Regulates frequency and provides high-pressure protection	 <p>63HS</p> <p>Pressure 0~3.60 MPa [522psi] Vout 0.5~3.5V 0.071V/0.098 MPa [14psi] Pressure [MPa] =1.38 x Vout [V]-0.69 Pressure [psi] = (1.38 x Vout [V] - 0.69) x 145</p> <p>1 GND (Black) 2 Vout (White) 3 Vcc (DC5V) (Red)</p>	
Low-pressure sensor	63LS		1) Detects low pressure 2) Provides low-pressure protection	 <p>63LS</p> <p>Pressure 0~1.7 MPa [247psi] Vout 0.5~3.5V 0.173V/0.098 MPa [14psi] Pressure [MPa] =0.566 x Vout [V] - 0.283 Pressure [psi] = (0.566 x Vout [V] - 0.283) x 145</p> <p>1 GND (Black) 2 Vout (White) 3 Vcc (DC5V) (Red)</p>	
Pressure switch	63H1		1) Detects high pressure 2) Provides high-pressure protection	3.60MPa[522psi] OFF setting	

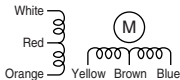

Part Name	Symbols (functions)	Notes	Usage	Specifications	Check method
Thermistor	TH11 (Discharge)		① Detects discharge temperature ② Protects high pressure  0°C : 698kΩ    60°C : 48kΩ 10°C : 413kΩ    70°C : 34kΩ 20°C : 250kΩ    80°C : 24kΩ 30°C : 160kΩ    90°C : 17.5kΩ 40°C : 104kΩ    100°C : 13.0kΩ 50°C : 70kΩ    110°C : 9.8kΩ	R120=7.465kΩ R25/120=4057 Rt = $7.465 \exp\{4057(\frac{1}{273+t} - \frac{1}{393})\}$	Resistance value check
	TH13		For LEV2 control Controls compressor suction superheat based on the difference with the saturation temperature yielded from the TH13 and 63LS values.	R0=15kΩ R0/80=3460 Rt = $15 \exp\{3460(\frac{1}{273+t} - \frac{1}{273})\}$  0°C : 15kΩ    25°C : 5.3kΩ 10°C : 9.7kΩ    30°C : 4.3kΩ 20°C : 6.4kΩ    40°C : 3.1kΩ	Resistance value check
	TH6 (Inlet water temperature)		Detects inlet water temperature		
	TH22 TH23		Controls LEV1, using TH22, TH23		
	TH8 (Outlet water temperature)		Detects water temperature at the outlet		
	THHS Inverter heat sink temperature	Heat sink	Controls inverter cooling fan, using THHS temperature.	R0=17kΩ R25/120=4170 Rt = $17 \exp\{4170(\frac{1}{273+t} - \frac{1}{323})\}$  0°C : 181kΩ    25°C : 50kΩ 10°C : 105kΩ    30°C : 40kΩ 20°C : 64kΩ    40°C : 26kΩ	
Solenoid valve	SV1 Bypass solenoid valve (defrost)	PWFY-P100,200 VM-E/E1/E2-AU only	A refrigerant bypass circuit that functions to prevent water heat exchanger from icing up during the defrost cycle.	AC220~240V Open when energized Closed when not energized	Continuity check with a tester
Linear expansion valve	SVG LEV leak protect solenoid valve (gas)	PWFY-P100, 200VM-E2-AU only	Stops LEV1W(a,b) leaking due to PHEX freezing prevention.	AC230V Open during energized Closed during not energized	Continuity check with a tester
	SVL LEV leak protect solenoid valve (liquid)	PWFY-P100, 200VM-E2-AU only	Stops LEV1W(a,b) leaking due to PHEX freezing prevention.	AC220~240V Open during energized Closed during not energized	Continuity check with a tester
	LEV1		① Adjusts superheat at the unit heat exchanger outlet during cooling ② Adjusts subcool at the unit heat exchanger outlet during hot water or heating	DC12V Opening of stepping motor driving valve 0-(1400) pulses	Refer to the section on continuity test with a tester Continuity between white-red-orange Continuity between yellow-brown-blue  
	LEV2	PWFY-P100 VM-E-BU only	Adjusts compressor suction superheat	DC12V Opening of a valve driven by a stepping motor 0-480 pulses (direct driven type)	
Switch	Flow switch	PWFY-P100,200 VM-E1/E2-AU only	Detects water flow	P100: ON when water flow is 1.1m³/h or more P200: ON when water flow is 1.8 m³/h or more	

## 7 Control

### [1] Dip Switch Functions and Their Factory Settings

#### 1. Unit

(1) Main board

Switch	Function	Function according to switch setting		Switch setting timing	
		OFF	ON		
SW1	1	TH0 thermistor selection	Water inlet thermistor TH6	Water outlet thermistor TH8	Before power on
	2	-	-	-	-
	3	Operation after power recovery *1	Remains stopped	Auto recovery (to the status before power failure)	Before power on
	4	Operation after power recovery	Depends on the SW1-3 setting	Forced to operate	Before power on
	5	-	-	-	-
	6	-	-	-	-
	7	Test-run mode	OFF	ON	Any time
	8	Error history deleted Resets the pre-error data overwrite protection. *4	Normal Keep overwrite protection	Deleted Reset overwrite protection *6	Any time
	9	Effective only when SW1-7 is set to ON and only on the HEX models.	Heating	Cooling	Any time
	10	Brine mode *2	Ineffective	Effective	Any time
SW2	1-10	For self-diagnosis/operation monitoring	-	-	Any time
SW3	1	Capacity setting (HEX unit only)	4HP	8HP (HEX unit only)	Before power on
	2	Service LED display selection	Display in Centigrade	Display in Fahrenheit	Any time
	3	-	-	-	-
	4	-	-	-	-
	5	Cumulative compressor operation time is deleted.	Normal	Deleted	Any time
	6	Pump interlock operation	During Thermo-ON or Thermo-OFF	During Thermo-ON only	Any time
	7	-	-	-	-
	8	-	-	-	-
	9	Heating Thermo OFF differential change *3			Any time
	10	Sets the restart interval for the delay mode. *4, *5	9 seconds	9 minutes and 59 seconds	Before power on
SW4	1	Do not change from factory setting.			
	2	Do not change from factory setting.			
	3	Use to change preset temperature range for the Heating ECO mode.	Booster : Ineffective HEX : Ineffective	Booster : 30°C to 50°C HEX : 30°C to 50°C	Before power on
	4	Use to change preset temperature range for the Anti-freeze mode.	Booster : Ineffective HEX : Ineffective	Booster : 10°C to 45°C HEX : 10°C to 45°C	Before power on
	5	-	-	-	-
	6	-	-	-	-
	7	-	-	-	-
	8	-	-	-	-
	9	-	-	-	-
	10	-	-	-	-
SW5	1	Enabling/disabling ACCT sensor error detection	Error detection enabled	Error detection disable (No load operation is possible)	Any time
	2	-	-	-	-
	3	-	-	-	-
	4	-	-	-	-

\*1 Valid only when SW1-4 is set to OFF

\*2 Refer to the Databook for the brine concentration.

\*3 The following changes can be made by changing the setting of the switch from OFF to ON.

0.5 → 1 → 0.5 → 2 → 0.5 → 3 → 0.5 → 4 → 0.5 → 5 → 0.5 → 6 → 0.5 → 7 → 0.5 → 8

\*4 This function is available on ver. 1.24 or later.

\*5 When setting DipSW3-10 to ON, make sure that the water flow rate in the system is greater than the minimum design amount.

\*6 This switch is reset when set from OFF to ON.

## 2. Frequency control <PWFY-P100VM-E-BU>

- The following table shows the frequency change of the inverter compressor during normal operation.

Model	Frequency/heating	Speed
PWFY-P100VM-E-BU	25~100Hz	2Hz/sec.

### (1) Pressure limit

The maximum limit of high pressure (Pd) is set for frequency level. If this limit is exceeded, the frequency will be reduced every 1 minute.

### (2) Discharge temperature limit

- Control is performed 1 min after compressor start-up and every 1 min thereafter.

### (3) Periodic frequency control

Frequency control other than the ones performed at startup, upon status change, and for protection is called periodic frequency control (conversent control) and is performed in the following manner.

#### ① Periodic control cycle

Periodic control is performed after the following time has passed

- 1 min after either compressor start up or the completion of defrost operation
- 1 min after frequency control by discharge temperature or by pressure limit

#### ② The amount of frequency change

The amount of frequency change is controlled to approximate the target value based on the set temperature.

## 3. Subcool control for Heating or Hot water mode (Linear expansion valve <LEV1W(a,b)>)

- The amount of subcool is controlled by LEV1W(a,b) based on the differential between liquid refrigerant temperature (TH22) and condensing temperature every 1 minute.

### • Defrost operation

#### (1) Booster Unit (PWFY-P100VM-E-BU)

It stays closed at (LEV1W = 0 pulse) during defrost operation

#### (2) HEX Unit (PWFY-P100, 200VM-E/E1/E2-AU)

It depends on inletwater temperature (TH6) as below.

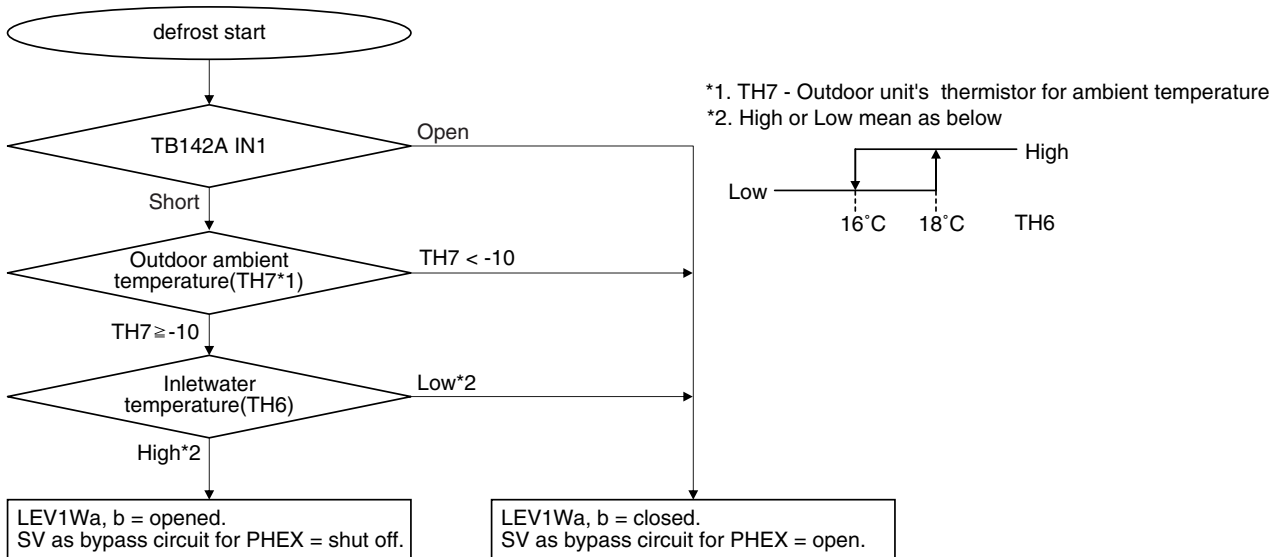

## 4. Superheat control for Cooling mode (Linear expansion valve <LEV1Wa,b>)

### < PWFY-P100/200VM-E/E1/E2-AU>

- The amount of superheat is controlled by LEV1W(a,b) based on the differential between gas refrigerant temperature (TH23) and liquid refrigerant temperature (TH22) every 1 minute.

## 5. Control at initial startup

- When the unit is started for the first time, it will run the following course of operation.

### <Flow chart of initial operation mode>

\*Do not operate the unit in the initial operation mode 12 or more hours after power on.

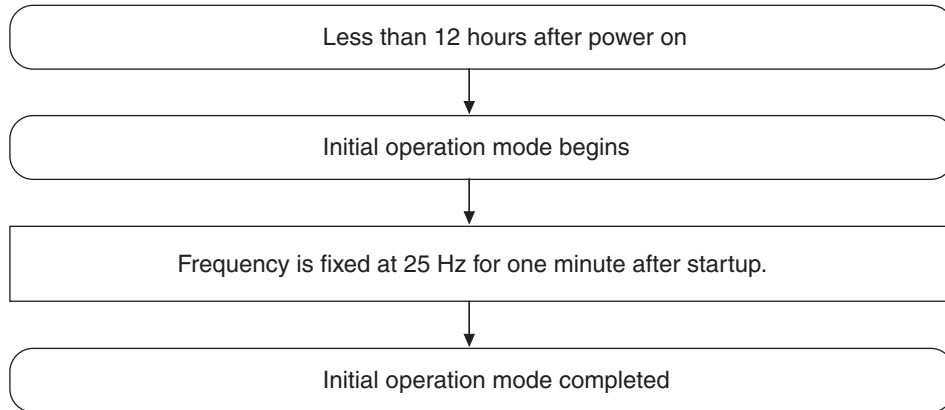

## 6. Control box cooling System <PWFY-P100VM-E-BU>

On the PWFY-P100VM-E-BU model, the cooling fan operates for the period between one minute before compressor startup and one minute after compressor stoppage to prevent INV temperature from rising.

## 7. Super heat control of the high-side (R134a) of the binary cycle.

### (Linear expansion valve <LEV2W>) <PWFY-P100VM-E-BU>

#### (1) LEV2W control

##### (a) LEV2W control range.

$$0 \leq \text{LEV2W} \leq 480 \text{ pulses}$$

##### (b) LEV2W Control method

Hot Water			LEV2W
Pd/Ps < 1.7			Down
Pd/Ps ≥ 1.7	TdSH ≤ 15		Down
		TdSH > 15	
		SH < 2	Down
		2 < SH < 4	Down
		4 ≤ SH ≤ 5	0
		5 < SH ≤ 7	Up
	7 < SH	Up	

$$*TdSH = TH11 - T(63HS)$$

$$*Pd/Ps = 6SHS/63LS$$

$$*SH = TH13 - T(63LS)$$

## 8. Operation mode

### (1) Unit operation modes

An operation mode can be selected from the following modes on the remote controller.

	PWFY-P100VM-E-BU	PWFY-P100/P200VM-E/E1/E2-AU
①	Hot Water	Heating
②	-	Cooling

## 8 Test Run

### [1] Check Items before Test Run

1	Check refrigerant leak, loose power source or transmission line if found.
2	Measure resistance between the power source terminal block and ground with a 500V megger to confirm it is exceeding 1.0MΩ. Notes: 1. Do not operate the unit when the insulation resistance stays below 1.0MΩ. 2. Never apply a megger to the transmission line terminal block. Otherwise, the control board will be damaged. 3. At immediately after installation or when the unit is left with the main power source turned off for a long time, the insulation resistance between the power source terminal block and ground may drop down to 1MΩ approximately due to refrigerant accumulated inside the compressor. 4. Never measure the insulation resistance of the transmission terminal block for the MA remote controller.
3	Confirm that the ball valves of outdoor unit are fully opened at both gas and liquid sides. Note: 1. Make sure to tighten the cap.
4	Check the input voltage to the power supply terminal block TB2.

### [2] Test Run Method

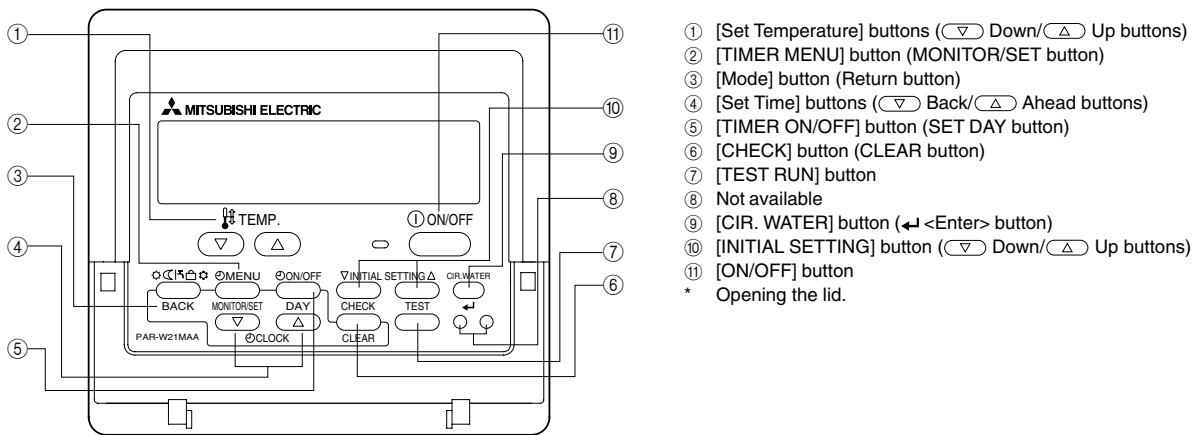

Operation procedures	
Turn on the main power.	→ "PLEASE WAIT" appears on the LCD for up to five minutes.
Press the <b>Test</b> button twice.	→ "TEST RUN" will appear on the LCD.
Cancel the test run by pressing the <b>ON/OFF</b> button.	→ Stop
Note 1: Refer to the following pages if an error code appears on the remote controller or when the unit malfunctions. 2: The OFF timer will automatically stop the test run after 2 hours.	

### [3] Refrigerant

Unit type	PWFY-P100VM-E-BU
Refrigerant type	R134a
Refrigerant charge	1.1kg

#### [4] Symptoms that do not Signify Problems

Symptom	Remote controller display	Cause
Fan does not stop while stopping operation.	<b>Extinguished</b>	When the auxiliary heater is turned on, fan operates for one minute after stopping to remove residual heat.
The display shown right will appear on the indoor unit remote controller for about 5 minutes when the main power source is turned on.	<b>"PLEASE WAIT" ("HO") blinking display</b>	The system is under starting up. Operate the remote controller after the blinking of "PLEASE WAIT" ("HO") is disappeared.
Sound of the refrigerant flow is heard from the indoor unit immediately after starting operation.	<b>Normal display</b>	This is caused by the transient instability of the refrigerant flow and is normal.

#### [5] Standard operation data

	PWFY-P100VM-E-BU	
Indoor DB/WB	°C	20/-
Outdoor DB/WB	°C	7/6
Water flow rate	m <sup>3</sup> /h	2.15
Comp discharge temp.	°C	92.0
Water inlet	°C	65.0
Water outlet	°C	70.0
Frequency	HZ	100
High pressure	kg/cm <sup>2</sup>	22.5
Tc	°C	74.4
Low pressure	kg/cm <sup>2</sup>	7.8
Te	°C	34.4
LEV1	pulse	680
LEV2	pulse	380

		PWFY-P100VM-E/E1/E2-AU	
		Heating	Cooling
Indoor DB/WB	°C	20/-	20/-
Outdoor DB/WB	°C	7/6	35/24
Water flow rate	m <sup>3</sup> /h	2.15	1.93
Water inlet	°C	30.0	23.0
Water outlet	°C	35.0	18.0
High pressure	kg/cm <sup>2</sup>	31.5	28.1
Tc	°C	51.9	47
Low pressure	kg/cm <sup>2</sup>	6.5	7.1
Te	°C	-1.5	0
LEV1	pulse	474	220

		PWFY-P200VM-E/E1/E2-AU	
		Heating	Cooling
Indoor DB/WB	°C	20/-	20/-
Outdoor DB/WB	°C	7/6	35/24
Water flow rate	m <sup>3</sup> /h	4.3	3.86
Water inlet	°C	30.0	23.0
Water outlet	°C	35.0	18.0
High pressure	kg/cm <sup>2</sup>	31	28.4
Tc	°C	50.5	47.5
Low pressure	kg/cm <sup>2</sup>	6.7	7.4
Te	°C	-1.2	1.5
LEV1	pulse	480	220

## 9 Troubleshooting

### [1] Check Code List

#### 1. Error Code and Preliminary Error Code List

BU: PWFY-P100VM-E-BU  
 AU: PWFY-P100, 200VM-E/E1/E2-AU

Error Code	Preliminary error code	Error (preliminary) detail code	Error code definition	Searched unit		Notes
				BU	AU	
0403	4300	-	Serial communication error	O		
1102	1202	-	Discharge temperature fault	O		
1301	1401	-	Low pressure fault	O		
1302	-	-	High pressure fault 1	O		
1302	1402	-	High pressure fault 2	O		
2000	2100	-	Pump interlock error	O		
2000	2100	-	Flow switch error		O	
2134	2234	-	Abnormal water temperature	O	O	
2135	2235	-	Water-source heat exchanger freezing	O	O	
4102	4152	-	Open phase	O		
4115	4165	-	Power supply signal sync error	O		
4220 (Note)	4320 (Note)	[01]	Bus voltage error (PAM damage)	O		
		[108]	Abnormal bus voltage drop	O		
		[109]	Abnormal bus voltage rise	O		
		[121]	Converter Fo error	O		
4230	4330	-	Heatsink overheat protection	O		
4250 (Note)	4350 (Note)	[101]	IPM error	O		
		[102]	ACCT overcurrent (H/W detection)	O		
5102	1210	-	Temperature sensor fault (TH22)	O	O	
5103	1209	-	Temperature sensor fault (TH23,TH13)	O	O	
5104	1202	-	Temperature sensor fault (TH11)	O		
5106	2237	-	Temperature sensor fault (TH6)	O	O	
5108	2238	-	Temperature sensor fault (TH8)	O	O	
5110	1214	-	Temperature sensor fault (THHS)	O		
5201	1402	-	High-pressure sensor fault	O		
5202	1401	-	Low-pressure sensor fault	O		
5301	4300	-	ACCT sensor Shor circuit/open circuit	O		
		[115]	ACCT sensor fault	O		

## [2] Responding to Error Display on the Remote Controller

### 1. Error Code

<b>0403</b>
-------------

**Serial communication error**

### 2. Error definition and error detection method

Serial communication error between the control board and the INV board on the compressor, and between the control board and the Fan board

Detail code 01: Between the control board and the INV board

Detail code 05: Between the control board and the Fan board

### 3. Cause, check method and remedy

#### (1) Faulty wiring

Check the following wiring connections.

##### 1) Between Control board and INV board

Control board	INV board
CN2	CN2
CN4	CN4

#### (2) INV board failure and Control board failure

Replace the INV board or control board when the power turns on automatically, even if the power source is reset.

#### Note

Refer to section - 5 - "Inverter" under part [3] "Trouble shooting principal parts" for error codes related to the inverter.(page 70)



### 1. Error Code

1102

#### Abnormal discharge air temperature

### 2. Error definition and error detection method

- 1) If a discharge temperature of 115 °C [239°F] or higher is detected (first detection), units will stop, go into the 3-minute restart delay mode, and automatically restart after three minutes.
- 2) If a discharge temperature of 115°C [239°F] or higher is detected again (second detection) within 30 minutes of the first stoppage of the units as described above, units will stop, go into the 3 minute restart delay mode, and automatically restart after three minutes.
- 3) If a discharge temperature of 115°C [239°F] or higher is detected again (third detection) within 30 minutes of the second stoppage of the units as described above, the units will come to an abnormal stop, and the error code "1102" will appear.
- 4) If a discharge temperature of 115°C [239°F] or higher is detected after 30 minutes have elapsed after a stoppage (first or second) of the unit as described above, it is regarded as the first detection and the sequence as described above will be followed.
- 5) The period of 30 minutes after a stoppage of the units is considered a preliminary error, and a preliminary error code will appear on the LED.

### 3. Cause, check method and remedy

Cause	Check method and remedy
(1) Gas leak, gas shortage	Refer to the page on refrigerant amount evaluation.(page 42)
(2) Overload operation	Check the operating conditions and operational status.
(3) LEV actuation failure	Refer to the section on troubleshooting the LEV.(page 64)
(4) Thermistor failure (TH11)	Check the thermistor resistor.(page 55)
(5) Input circuit failure on the controller board thermistor	Check the inlet air temperature on the LED monitor.
(6) Shortage of circulating water	Check that the pump meets the required specifications. 0.6m <sup>3</sup> /h~2.15m <sup>3</sup> /h
(7) Clogged heat vent outlet	Check that the heat vent outlet (located on the left side of the unit) is not clogged.

### 1. Error Code

1301

#### Abnormal low pressure

### 2. Error definition and error detection method

**When starting the compressor from Stop Mode for the first time if low pressure reads 0.098MPa [14psi] immediately before start-up, the operation immediately stops.**

### 3. Cause, check method and remedy

Cause	Check method and remedy
(1) Inner pressure drop due to a leakage	Refer to the section on troubleshooting the low pressure sensor.(page 62)
(2) Low pressure sensor failure	
(3) Short-circuited pressure sensor cable due to torn outer rubber	
(4) A pin on the male connector is missing.	
(5) Disconnected wire	
(6) Failure of the low pressure input circuit on the controller board	
(7) Shortage of circulating water	Check that the pump meets the required specifications. 0.6m <sup>3</sup> /h~2.15m <sup>3</sup> /h

**1. Error Code**

**1302**

**Abnormal high pressure 1**

**2. Error definition and error detection method**

- 1) If a pressure of 3.23MPa [468 psi ] or higher is detected during operation, units will stop, go into the 3 minute restart delay mode, and automatically restart after three minutes.
- 2) If a pressure of 3.23MPa [468 psi ] or higher is detected again (second detection) within 30 minutes of the first stoppage of the units, units will stop, go into the 3 minute restart delay mode, and automatically restart after three minutes.
- 3) If a pressure of 3.23 MPa [468 psi ] or higher is detected again (third detection) within 30 minutes of the second stoppage of the units, the unit will come to an abnormal stop, and the check code "1302" will appear on the display.
- 4) If a pressure of 3.23MPa [468 psi ] or higher is detected after 30 minutes have elapsed after a stoppage of the units, it is regarded as the first detection, and the sequence as described in section 1) above is followed.
- 5) Preliminary error code will remain on the LED for 30 minutes after the stoppage of the unit.
- 6) The outdoor unit makes an error stop immediately when not only the pressure sensor but also the pressure switch detects 3.60<sup>+0,-0.15</sup> MPa [522<sup>+0,-22</sup> psi]

**3. Cause, check method and remedy**

Cause	Check method and remedy
(1) LEV actuation failure	Refer to the section on troubleshooting the LEV.(page 64)
(2) Pressure sensor failure	Refer to the page on the troubleshooting of the high pressure sensor. (page 61)
(3) Failure of the thermistor input circuit and pressure sensor input circuit on the controller board	Check the temperature and the pressure of the sensor with LED monitor.
(4) Disconnected male connector on the pressure switch (63HS) or disconnected wire	Check the temperature and the pressure of the sensor with LED monitor.
(5) Shortage of circulating water	Check that the pump meets the required specifications. 0.6m <sup>3</sup> /h~2.15m <sup>3</sup> /h

**1. Error Code**

**1302**

**Abnormal high pressure 2 (outdoor unit)**

**2. Error definition and error detection method**

**If the pressure of 0.098MPa [14psi] or lower is registered on the pressure sensor immediately before start-up, it will trigger an abnormal stop, and error code "1302" will be displayed.**

**3. Cause, check method and remedy**

Cause	Check method and remedy
(1) Inner pressure drop due to a leakage.	Refer to the page on the troubleshooting of the high pressure sensor.(page 61)
(2) Pressure sensor failure	
(3) Shorted-circuited pressure sensor cable due to torn outer rubber	
(4) A pin on the male connector on the pressure sensor is missing or contact failure	
(5) Disconnected pressure sensor cable	
(6) Failure of the pressure sensor input circuit on the controller board	

1. Error Code

2000

Pump interlock error (BU only)

2. Error definition and error detection method

- Preliminary pump interlock error is detected when the pump interlock circuit becomes open while the units are stopped during Thermo-ON.
  - When a preliminary error is detected, units will go into the Thermo-OFF state and into the restart-prevention mode.
  - When the amount of time listed below has elapsed since the time when a given preliminary error was detected, an error code "2000" will be detected, and the units will come to an abnormal stop.
    - ♦DipSW3-10=OFF 9 seconds \*1
    - ♦DipSW3-10=ON 9 minutes and 59 seconds \*1
- \*1 When the version of the software is before 1.24, this value will be 9 minutes and 59 seconds regardless of the DipSW settings.

3. Cause, check method and remedy

Cause	Check method and remedy
(1) Pump is not connected properly.	Check the pump for proper connection. Check the pump interlock circuit.

1. Error Code

2000

Flow switch error (AU only)

2. Error definition and error detection method

When the water flow rate of the water supply to the unit is the specified rate or less, the flow switch does not detect, and the unit will be stopped.

3. Cause, check method and remedy

Cause	Check method and remedy
(1) Water shortage	Check the water flow rate. Check the strainer for proper operation.

1. Error Code

2134

Abnormal water temperature

2. Error definition and error detection method

- In the case of BU and WH, if the value of TH6 becomes equal to or greater than 85°C, units will stop and go into the 3 minute restart delay mode.
- For a period of thirty minutes after units came to a stop is considered a preliminary error.

3. Cause, check method and remedy

Cause	Check method and remedy
(1) Pump is not connected properly.	Check the pump for proper connection.
(2) Thermistor fault	Replace thermistor TH6.
(3) Disconnected thermistor connector	Check the thermistor connector.

### 1. Error Code

**2135**

#### Water heat exchanger freeze up

### 2. Error definition and error detection method

Condition 1	Both TH22 and TH23 of 1°C or below have been detected for three minutes in a mode other than Heating Thermo-ON.	
Condition 2	If PWFY is running in Heating Thermo-ON mode when the defrost cycle starts	TH22 of -15°C or below has been detected for 3 continuous minutes starting from 2 minutes after the start of the defrost cycle.
	If PWFY is running in a mode other than Heating Thermo-ON mode when the defrost cycle starts	TH22 of -15°C or below has been detected for 3 continuous minutes starting from 4 minutes after the start of the defrost cycle.
Condition 3	TH22 of -8°C or below has been detected for 90 seconds except during the defrost cycle and while PWFY is running in modes other than Cooling Thermo-ON.	
Condition 4	TH6 or TH8 of 2°C or below has been detected while the PWFY unit is in operation.	
Condition 5	The PWFY unit has a power failure while the outdoor unit is in the defrost cycle.	

♦For a period of 60 minutes after the units came to a stop is considered a preliminary error.

### 3. Cause, check method and remedy

Cause	Check method and remedy
(1) Pump is not connected properly. Shortage of circulating water	Check the pump for proper connection. Check the amount of circulating refrigerant.
(2) Thermistor fault	Replace thermistor TH6, TH8.
(3) Disconnected thermistor connector	Check the thermistor connector.

### 1. Error Code

**4102**

#### Open phase

### 2. Error definition and error detection method

- ♦ An open phase of the power supply (L phase, N phase) was detected at power on.
- ♦ The N phase current is outside of the specified range.

#### Note

The open phase of the power supply may not always be detected if a power voltage from another circuit is applied.

### 3. Cause, check method and remedy

Cause	Check method and remedy
(1) Power supply problem ♦ Open phase voltage of the power supply ♦ Power supply voltage drop	Check the input voltage to the power supply terminal block TB2.
(2) Noise filter problem ♦ Coils (L1 to L3) problem ♦ Circuit board failure	♦ Check the coil connections. ♦ Check for coil burnout. ♦ Check that the voltage at CNAC2 connector is 198V or above.
(3) Wiring failure	Confirm that the voltage at the control board connector CNAC is 198 V or above. If the voltage is below 180V, check the wiring between CNAC2 on the noise filter board and CNAC on the control board. Check the wiring between the power supply terminal block (TB2) and the tab terminals LI and NI on the noise filter board. Check the wiring between the tab terminals LO and NO on the noise filter board and the ACL. Check the wiring between the ACL and the tab terminals R and S on the INV board. Check the wiring between CN5 on the noise filter board and CN5 on the INV board.
(4) Blown fuse	Check for a blown fuse (F01) on the control board. →If a blown fuse is found, check for a short-circuiting or earth fault of the actuator.
(5) INV board failure	Replace the inverter if this problem is detected after the compressor has gone into operation.
(6) Control board failure	Replace the control board if none of the above is causing the problem.

1. **Error Code**

**4115**

**Power supply signal sync error**

2. **Error definition and error detection method**

The frequency cannot be determined when the power is switched on.

3. **Cause, check method and remedy**

Cause		Check method and remedy
(1)	Power supply error	Check the voltage of the power supply terminal block (TB2).
(2)	Noise filter problem <ul style="list-style-type: none"><li>◆ Coils (L1 to L3) problem</li><li>◆ Circuit board failure</li></ul>	<ul style="list-style-type: none"><li>◆ Check the coil connections.</li><li>◆ Check for coil burnout.</li><li>◆ Confirm that the voltage at the CNAC2 connector is 198 V or above.</li></ul>
(3)	Faulty wiring	Check fuse F01 on the control board.
(4)	Wiring fault Between CNAC2 on the noise filter board and CNAC on the control board	Confirm that the voltage at the control board connector CNAC is 198 V or above. Check the wiring between the power supply terminal block (TB2) and the tab terminals LI and NI on the noise filter board.
(5)	Control board failure	If none of the items described above is applicable, and if the trouble reappears even after the power is switched on again, replace the control board.

## 1. Error Code

**4220**

### Abnormal bus voltage drop (Detail code 108)

## 2. Error definition and error detection method

If Vdc 200V or less is detected during Inverter operation. (S/W detection)

## 3. Cause, check method and remedy

### (1) Power supply environment.

Check whether the unit makes an instantaneous stop when the detection result is abnormal or a power failure occurs.  
Check that the interphase power supply voltage is 198V or above.

### (2) Voltage drop detected.

♦If the bus voltage that appears on the LED monitor is 200V or below during inverter operation, check the following.

- 1) Replace the control board if the voltage across pins 1-3 of CN631 on the control board is 200V or above during inverter operation.
- 2) Checking the wiring connections
  - ① Check the wiring between the INV board and CN631 on the control board.
  - ② Check the wiring between the ACL and the tab terminals R and S on the INV board.
  - ③ Check the wiring between the tab terminals LO and NO on the noise filter board and the ACL.
  - ④ Check the wiring between the power supply terminal block (TB2) and the tab terminals LI and NI on the noise filter board.
- 3) Noise filter board fault
  - ① Check for broken coils (L1-L3).
  - ② Check the RS value →  $20\Omega \pm 5\%$ .
- 4) Replace the INV board if no problems are found with the above items.

#### Note

Refer to section - 5 - "Inverter" under part [3] "Trouble shooting principal parts" for error codes related to the inverter.(page 70)

---

## 1. Error Code

**4220**

### Bus voltage error (PAM damage) (Detail code 01)

## 2. Error definition and error detection method

PWM circuit error on the INV board is detected.

## 3. Cause, check method and remedy

### (1) INV board failure

Replace the INV board.

#### Note

Refer to section - 5 - "Inverter" under part [3] "Trouble shooting principal parts" for error codes related to the inverter.(page 70)

### 1. Error Code

**4220**

**Abnormal bus voltage rise (Detail code 109)**

### 2. Error definition and error detection method

If  $V_{dc} \geq 380V$  is detected during inverter operation.

### 3. Cause, check method and remedy

#### (1) Different voltage connection.

Check the power supply voltage on the power supply terminal block (TB2).

#### (2) INV board failure.

Replace the INV board if no problems are found with the power supply.

#### Note

Refer to section - 5 - "Inverter" under part [3] "Trouble shooting principal parts" for error codes related to the inverter.(page 70)

---

### 1. Error Code

**4220**

**Converter Fo error (Detail code 121)**

### 2. Error definition and error detection method

INV board converter circuit error is detected.

### 3. Cause, check method and remedy

#### (1) INV board failure

Replace the INV board.

#### Note

Refer to section - 5 - "Inverter" under part [3] "Trouble shooting principal parts" for error codes related to the inverter.(page 70)

### 1. Error Code

**4230**

#### Heat sink overheat protection

### 2. Error definition and error detection method

When the heat sink temperature (THHS) remains at or above 85°C is detected.

### 3. Cause, check method and remedy

Cause	Check method and remedy
(1) Checking the fan wiring.	Check connectors CN506A and CN506B on the control board. Check the fan wiring for breakage and damage.
(2) Checking the control board output voltage	Check the output voltage at CN506A and CN506B on the control board during inverter operation. Criteria : Output voltage $\geq$ 22V Replace the control board if no voltage is output during inverter operation. Replace the fan if voltage is output from the control board but the fan does not operate.
(3) Checking the air passage for blockage	Check the heatsink cooling air passage for blockage.
(4) THHS fault	1) Check INV board IGBT for proper connection. Check that heatsink on IGBT is installed properly. 2) Check the THHS wiring for damage. Replace the THHS sensor if problems are found. 3) Check the THHS sensor value on the LED monitor. Replace the THHS sensor if the values are abnormal.

#### Note

Refer to section - 5 - "Inverter" under part [3] "Trouble shooting principal parts" for error codes related to the inverter.(page 70)



**1. Error Code**

**4250**

**IPM error (Detail code 101)**

**2. Error definition and error detection method**

Overcurrent is detected while power module error detection signal is output.

**3. Cause, check method and remedy**

Cause	Check method and remedy
(1) Check the inverter output wiring for proper connection.	Check the fan wiring for breakage and damage. Check that the wiring is connected with correct polarity.
(2) Compressor failure	Check the compressor for earth fault and short circuit. Replace the INV board if no problems are found with the above items.

**Note**

Refer to section - 5 - "Inverter" under part [3] "Trouble shooting principal parts" for error codes related to the inverter.(page 70)

**1. Error Code**

**4250**

**ACCT overcurrent (H/W detection) (Detail code 102)**

**2. Error definition and error detection method**

Overcurrent 34.5Apeak or 16Arm and above is detected

**3. Cause, check method and remedy**

Cause	Check method and remedy
(1) Check the inverter output wiring for proper connection.	Check the fan wiring for breakage and damage. Check that the wiring is connected with correct polarity.
(2) Compressor failure	Check the compressor for earth fault and short circuit. Replace the INV board if no problems are found with the above items.

**Note**

Refer to section - 5 - "Inverter" under part [3] "Trouble shooting principal parts" for error codes related to the inverter.(page 70)

## 1. Error Code

**5102**

**TH22 temperature sensor failure (BU, AU)**

**5103**

**TH13, TH23 temperature sensor failure (BU, AU)**

**5104**

**TH11 temperature sensor failure (BU)**

**5106**

**TH6 temperature sensor failure (BU, AU)**

**5108**

**TH8 temperature sensor failure (BU, AU)**

## 2. Error definition and error detection method

- When a short (high temperature intake) or an open (low temperature intake) of the thermistor is detected (the first detection), the outdoor unit stops, turns to anti-restart mode for 3 minutes, and restarts when the detected temperature of the thermistor.
- When a short or an open is detected again (the second detection) after the first restart of the outdoor unit, the outdoor unit stops, turns to anti-restart mode for 3 minutes, and restarts in 3 minutes when the detected temperature is within the normal range.
- When a short or an open is detected again (the third detection) after the previous restart of the outdoor unit, the outdoor unit makes an error stop.
- When a short or an open of the thermistor is detected just before the restart of the outdoor unit, the outdoor unit makes an error stop, and the error code "5102", "5103", "5104", "5105", "5106" or "5108" will appear.
- During 3-minute antirestart mode, preliminary errors will be displayed on the LED display.
- A short or an open described above is not detected for 10 minutes after the compressor start, during defrost mode, or for 3 minutes after defrost mode.

## 3. Cause, check method and remedy

Cause		Check method and remedy
(1)	Thermistor failure	Check thermistor resistance.
(2)	Pinched lead wire	Check for pinched lead wire.
(3)	Torn wire coating	Check for wire coating.
(4)	A pin on the male connector is missing or contact failure	Check connector.
(5)	Disconnected wire	Check for wire.
(6)	Thermistor input circuit failure on the control board	Check the intake temperature of the sensor with the LED monitor. When the temperature is far different from the actual temperature, replace the control board.

<Reference>

	Short detection	Open detection
TH22	70 °C [158 °F] and above (0.4 k $\Omega$ )	-40 °C [-40 °F] and below (130 k $\Omega$ )
TH13, TH23	110 °C [230 °F] and above (0.4 k $\Omega$ )	-40 °C [-40 °F] and below (130 k $\Omega$ )
TH11	240 °C [464 °F] and above (0.57 k $\Omega$ )	0 °C [32 °F] and below (698 k $\Omega$ )
TH6	70 °C [158 °F] and above (0.4 k $\Omega$ )	-40 °C [-40 °F] and below (130 k $\Omega$ )
TH8	70 °C [158 °F] and above (1.14 k $\Omega$ )	-40 °C [-40 °F] and below (130 k $\Omega$ )

**1. Error Code**

**5110**

**Heat sink failure**

**2. Error definition and error detection method**

When a short or an open of THHS is detected just before or during the inverter operation.

**3. Cause, check method and remedy**

Cause	Check method and remedy
(1) INV board failure	If the problem recurs when the unit is put into operation, replace the INV board.

**Note**

Refer to section - 5 - "Inverter" under part [3] "Trouble shooting principal parts" for error codes related to the inverter.(page 70)

---

**1. Error Code**

**5201**

**High pressure sensor failure (63HS)**

**2. Error definition and error detection method**

- If the high pressure sensor detects 0.098MPa [14psi] or less during the operation, the outdoor unit stops once, turns to antirestart mode for 3 minutes, and restarts after 3 minutes when the detected high pressure sensor is 0.098MPa [14psi] or more.
- If the high pressure sensor detects 0.098MPa [14psi] or less just before the restart, the outdoor unit makes an error stop, and the error code "5201" will appear.
- During 3-minute antirestart mode, preliminary errors will be displayed on the LED display.
- A error is not detected for 3 minutes after the compressor start, during defrost operation, or 3 minutes after defrost operation.

**3. Cause, check method and remedy**

Cause	Check method and remedy
(1) High pressure sensor failure	Refer to the page on the troubleshooting of the high pressure sensor. (9 [3] -1-(page 61))
(2) Pressure drop due to refrigerant leak	
(3) Torn wire coating	
(4) A pin on the male connector is missing or contact failure	
(5) Disconnected wire	
(6) High pressure sensor input circuit failure on the control board	

1. Error Code

**5202**

**Low-pressure sensor fault**

2. Error definition and error detection method

When a pressure sensor reading of 4.06 MPa [589 psi] or above is detected, error code "5202" will appear. The unit will continue its operation by using other sensors as a backup.

3. Cause, check method and remedy

Cause	Check method and remedy
(1) Low pressure sensor failure	Refer to the page on the troubleshooting of the high pressure sensor. (9 [3] -1-(page 61))
(2) Pressure drop due to refrigerant leak	
(3) Torn wire coating	
(4) A pin on the male connector is missing or contact failure	
(5) Disconnected wire	
(6) Low pressure sensor input circuit failure on the control board	

1. Error Code

**5301**

**ACCT sensor short circuit/open circuit**

2. Error definition and error detection method

Abnormal value is detected by the ACCT sensor detection circuit immediately before inverter startup.

3. Cause, check method and remedy

Cause	Check method and remedy
(1) INV board failure	Replace the INV board if compressor failure (see below) is ruled out.
(2) Compressor failure	Check the compressor for earth fault and short circuit.

1. Error Code

**5301**

**ACCT sensor fault (Detail code 115)**

2. Error definition and error detection method

When the formula "output current < 1.5 Arms" remains satisfied for 10 seconds while the inverter is in operation.

3. Cause, check method and remedy

Cause	Check method and remedy
(1) Inverter open output phase	Check the output wiring connections.
(2) Compressor failure	Check the compressor for earth fault and short circuit.
(3) INV board failure	If no problems are found with the above items, replace the INV board.

## **-1- Troubleshooting according to the remote controller malfunction or the external input error**

### **1. Phenomena**

Even if the operation button on the remote controller is pressed, the display remains unlit and the unit does not start running. (Power indicator  does not appear on the screen.)

### **2. Cause**

- 1) Power is not supplied to the unit.
  - ♦The main power to the unit is not turned on.
  - ♦Connectors on the circuit board are disconnected.
  - ♦The fuse on the circuit board is blown.
  - ♦Transformer fault or broken wiring
- 2) Incorrect wiring for the MA remote controller
  - ♦Disconnected wire for the MA remote controller or disconnected line to the terminal block.
  - ♦Short-circuited MA remote controller wiring
  - ♦Incorrect wiring of the MA remote controller cables
  - ♦Incorrect connection of the MA remote wiring to the terminal block for transmission line (TB5) on the indoor unit
  - ♦Wiring mixup between the MA remote controller cable and 200 VAC power supply cable
- 3) The number of the MA remote controllers that are connected to an indoor unit exceeds the allowable range (2 units).
- 4) The length or the diameter of the wire for the MA remote controller are out of specification.
- 5) Short circuit of the wire for the remote display output of the outdoor unit or reversed polarity connection of the relay.
- 6) Circuit board fault
- 7) MA remote controller failure

### **3. Check method and remedy**

- 1) Measure voltages of the MA remote controller terminal (among 1 to 3).
  - ♦If the voltage is between DC 9 and 12V, the remote controller is a failure.
  - ♦If no voltage is applied, check the causes 1) and 3) and if the cause is found, correct it.  
If no cause is found, refer to 2).
- 2) Remove the wire for the remote controller from the terminal block (TB15) on the MA remote controller for the indoor unit, and check voltage among 1 to 3.
  - ♦If the voltage is between DC 9 and 12 V, check the causes 2) and 4) and if the cause is found, correct it.
  - ♦If no voltage is applied, check the cause 1) and if the cause is found, correct it.  
If no cause is found, check the wire for the remote display output (relay polarity).  
If no further cause is found, replace the indoor unit board.

### 1. Phenomena

When the remote controller operation SW is turned on, the operation status briefly appears on the display, then it goes off, and the display lights out immediately, and the unit stops.

### 2. Cause

- 1) The power for the M-NET transmission line is not supplied from the outdoor unit.
- 2) Short circuit of the transmission line.
- 3) Incorrect wiring of the M-NET transmission line on the outdoor unit.

- Disconnected wire for the MA remote controller or disconnected line to the terminal block.
- The male power supply connectors on the multiple outdoor units are connected to the female power supply switch connector (CN40).

In the system to which the power supply unit for transmission lines is connected, the male power supply connector is connected to the female power supply switch connector (CN40) on the outdoor unit.

- 4) Broken M-NET transmission line on the unit side
- 5) Faulty wiring or loose connector between the terminal block for M-NET transmission line connection (TB5) on the unit and CM2M on the indoor unit circuit board

### 3. Check method and remedy

- 1) When 2) and 3) above apply, check code 7102 will be displayed on the self-diagnosis LED.

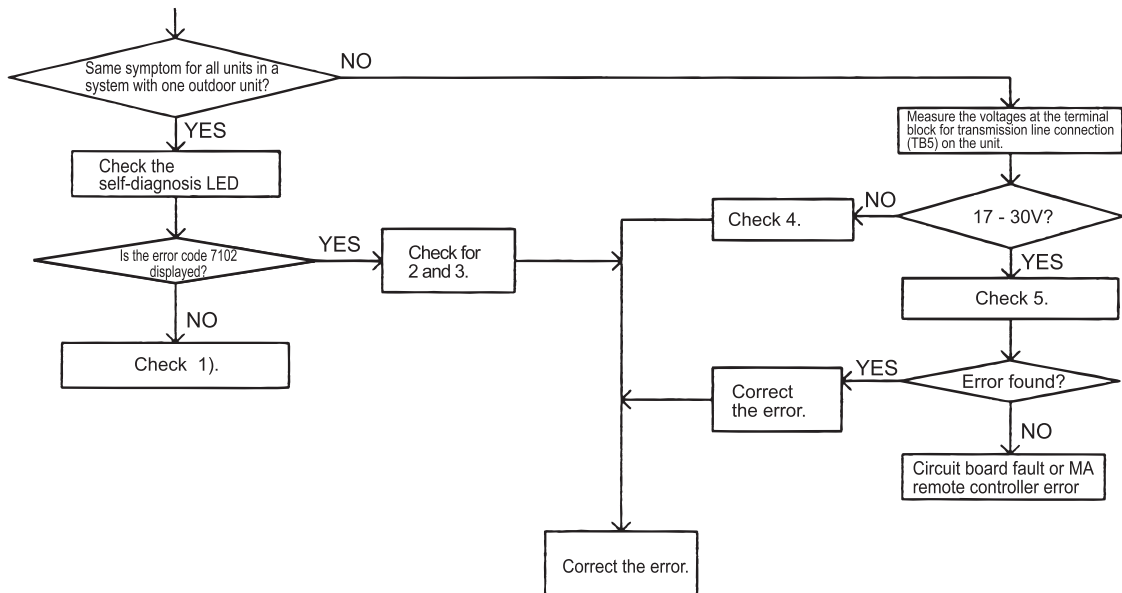

### 1. Phenomena

"HO" or "PLEASE WAIT" display on the remote controller does not disappear, and no operation is performed even if the button is pressed. ("HO" or "PLEASE WAIT" display will normally turn off 5 minutes later after the power on.)

### 2. Cause

- 1) The power for the M-NET transmission line is not supplied from the outdoor unit.
- 2) Short-circuited transmission line
- 3) Incorrect wiring of the M-NET transmission line on the outdoor unit.
  - Disconnected wire for the MA remote controller or disconnected line to the terminal block.
  - The male power supply connectors on the multiple outdoor units are connected to the female power supply switch connector (CN40).

In the system to which the power supply unit for transmission lines is connected, the male power supply connector is connected to the female power supply switch connector (CN40) on the outdoor unit
- 4) Broken M-NET transmission line on the unit side
- 5) Faulty wiring or loose connector between the terminal block for M-NET transmission line connection (TB5) on the unit and CM2M on the indoor unit circuit board
- 6) Incorrect wiring for the MA remote controller
  - Short-circuited wire for the MA remote controller
  - Disconnected wire for the MA remote controller (No.2) and disconnected line to the terminal block.
  - Reversed daisy-chain connection between groups
  - Incorrect wiring for the MA remote controller to the terminal block for transmission line connection (TB5) on the indoor unit
  - The M-NET transmission line is connected incorrectly to the terminal block (TB13) for the MA remote controller.
- 7) The sub/main setting of the MA remote controller is set to sub.
- 8) 2 or more main MA remote controllers are connected.
- 9) Circuit board fault (MA remote controller communication circuit)
- 10) Remote controller failure
- 11) Outdoor unit failure

### 3. Check method and remedy

- 1) When 2) and 3) above apply, check code 7102 will be displayed on the self-diagnosis LED.

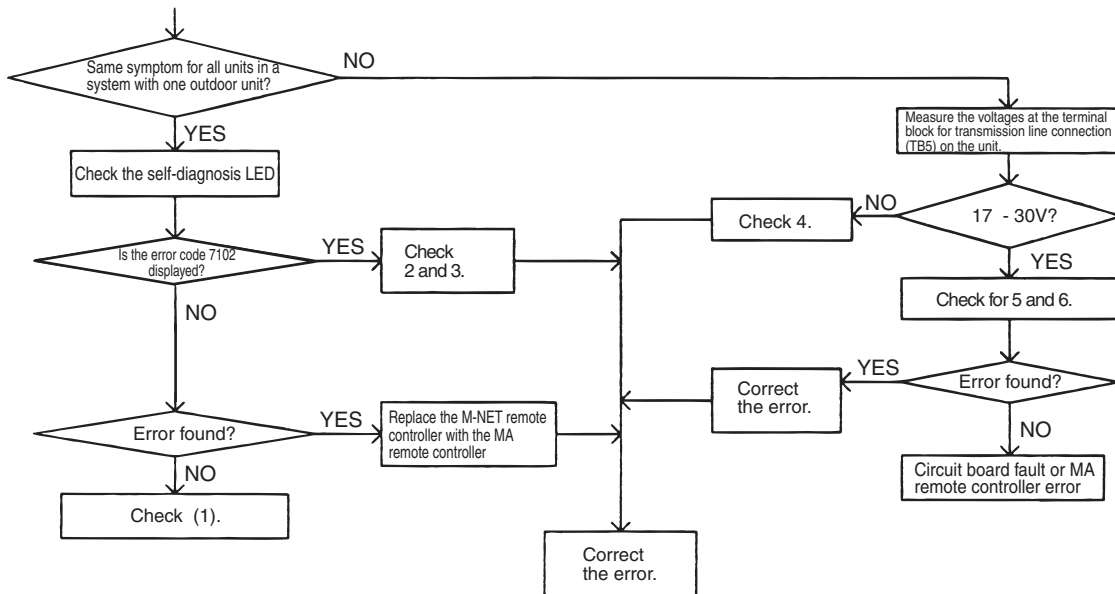

### [3] Troubleshooting Principal Parts

#### -1- High-Pressure Sensor (63HS)

##### 1. Compare the pressure that is detected by the high pressure sensor, and the high-pressure gauge pressure to check for failure.

By configuring the digital display setting switch (SW1) as shown in the figure below, the pressure as measured by the high-pressure sensor appears on the LED1 on the control board.

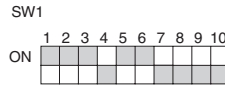

##### (1) While the sensor is stopped, compare the gauge pressure and the pressure displayed on self-diagnosis LED1.

- 1) When the gauge pressure is between 0 and 0.098MPa [14psi], internal pressure is caused due to gas leak.
- 2) When the pressure displayed on self-diagnosis LED1 is between 0 and 0.098MPa [14psi], the connector may be defective or be disconnected. Check the connector and go to (4).
- 3) When the pressure displayed on self-diagnosis LED1 exceeds 3.60MPa [522psi], go to (3).
- 4) If other than 1), 2) or 3), compare the pressures while the sensor is running. Go to (2).

##### (2) Compare the gauge pressure and the pressure displayed on self-diagnosis LED1 while the sensor is running. (Com-pare them by MPa [psi] unit.)

- 1) When the difference between both pressures is within 0.098MPa [14psi], both the high pressure sensor and the control board are normal.
- 2) When the difference between both pressures exceeds 0.098MPa [14psi], the high pressure sensor has a problem. (performance deterioration)
- 3) When the pressure displayed on self-diagnosis LED1 does not change, the high pressure sensor has a problem.

##### (3) Remove the high pressure sensor from the control board to check the pressure on the self-diagnosis LED1.

- 1) When the pressure displayed on self-diagnosis LED1 is between 0 and 0.098MPa [14psi], the high pressure sensor has a problem.
- 2) When the pressure displayed on self-diagnosis LED1 is approximately 3.60MPa [522psi], the control board has a problem.

##### (4) Remove the high pressure sensor from the control board, and short-circuit between the No.2 and 3 connectors (63HS) to check the pressure with self-diagnosis LED1.

- 1) When the pressure displayed on the self-diagnosis LED1 exceeds 3.60MPa [522psi], the high pressure sensor has a problem.
- 2) If other than 1), the control board has a problem.

#### 2. Pressure sensor configuration

The high pressure sensor consists of the circuit shown in the figure below. If DC 5V is applied between the red and the black wires, voltage corresponding to the pressure between the white and the black wires will be output, and the value of this voltage will be converted by the microcomputer. The output voltage is 0.1028V per 0.098MPa [14psi].

##### Note

The pressure sensor on the body side is designed to connect to the connector. The connector pin number on the body side is different from that on the control board side.

	Body side	Control board side
Vcc	Pin 1	Pin 3
Vout	Pin 2	Pin 2
GND	Pin 3	Pin 1

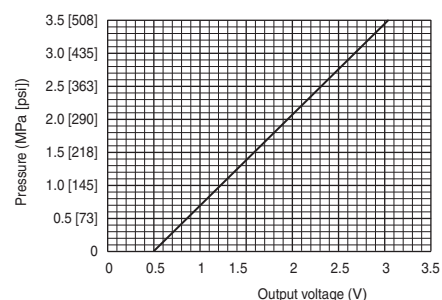
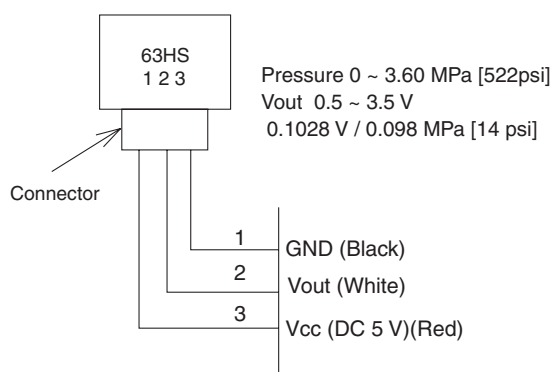



## -2- Low-Pressure Sensor (63LS)

### 1. Compare the pressure that is detected by the low pressure sensor, and the low pressure gauge pressure to check for failure.

By configuring the digital display setting switch (SW1) as shown in the figure below, the pressure as measured by the low-pressure sensor appears on the LED1 on the control board.

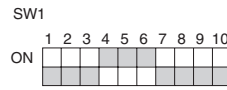

#### (1) While the sensor is stopped, compare the gauge pressure and the pressure displayed on self-diagnosis LED1.

- 1) When the gauge pressure is between 0 and 0.098MPa [14psi], internal pressure is caused due to gas leak.
- 2) When the pressure displayed on self-diagnosis LED1 is between 0 and 0.098MPa [14psi], the connector may be defective or be disconnected. Check the connector and go to (4).
- 3) When the pressure displayed on self-diagnosis LED1 exceeds 1.7MPa [247psi], go to (3).
- 4) If other than 1), 2) or 3), compare the pressures while the sensor is running. Go to (2).

#### (2) Compare the gauge pressure and the pressure displayed on self-diagnosis LED1 while the sensor is running. (Compare them by MPa [psi] unit.)

- 1) When the difference between both pressures is within 0.03MPa [4psi], both the low pressure sensor and the control board are normal
- 2) When the difference between both pressures exceeds 0.03MPa [4psi], the low pressure sensor has a problem. (performance deterioration)
- 3) When the pressure displayed on the self-diagnosis LED1 does not change, the low pressure sensor has a problem.

#### (3) Remove the low pressure sensor from the control board to check the pressure with the self-diagnosis LED1 display.

- 1) When the pressure displayed on the self-diagnosis LED1 is between 0 and 0.098MPa [14psi], the low pressure sensor has a problem.
- 2) When the pressure displayed on self-diagnosis LED1 is approximately 1.7MPa [247psi], the control board has a problem.
  - When the outdoor temperature is 30°C [86°F] or less, the control board has a problem.
  - When the outdoor temperature exceeds 30°C [86°F], go to (5).

#### (4) Remove the low pressure sensor from the control board, and short-circuit between the No.2 and 3 connectors (63LS:CN63LS) to check the pressure with the self-diagnosis LED1.

- 1) When the pressure displayed on the self-diagnosis LED1 exceeds 1.7MPa [247psi], the low pressure sensor has a problem.
- 2) If other than 1), the control board has a problem.

#### (5) Remove the high pressure sensor (63HS) from the control board, and insert it into the connector for the low pressure sensor (63LS) to check the pressure with the self-diagnosis LED1.

- 1) When the pressure displayed on the self-diagnosis LED1 exceeds 1.7MPa [247psi], the control board has a problem.
- 2) If other than 1), the control board has a problem.

### 2. Low-pressure configuration

The low pressure sensor consists of the circuit shown in the figure below. If DC5V is applied between the red and the black wires, voltage corresponding to the pressure between the white and the black wires will be output, and the value of this voltage will be converted by the microcomputer. The output voltage is 0.173V per 0.098MPa [14psi].

#### Note

The pressure sensor on the body side is designed to connect to the connector. The connector pin number on the body side is different from that on the control board side.

	Body side	Control board side
Vcc	Pin 1	Pin 3
Vout	Pin 2	Pin 2
GND	Pin 3	Pin 1

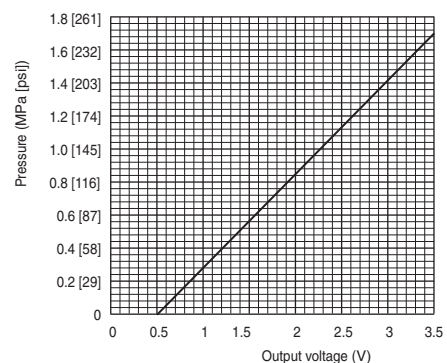
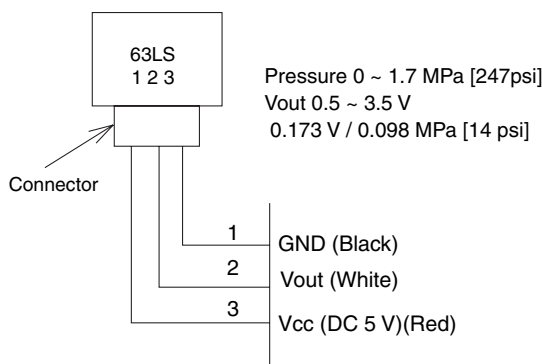

### -3- Solenoid Valve

Check whether the output signal from the control board and the operation of the solenoid valve match. Setting the self-diagnosis switch (SW1) as shown in the figure below causes the ON signal of each relay to be output to the LED's.

Each LED shows whether the relays for the following parts are ON or OFF. LEDs light up when relays are ON.

**Note**

The circuits on some parts are closed when the relays are ON. Refer to the following instructions.

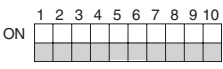
SW1		Display							
		LD1	LD2	LD3	LD4	LD5	LD6	LD7	LD8
	Upper			SV1					
	Lower								

When there is a problem with a solenoid valve, first check for loose solenoid valve coil, broken lead wire, incorrect connector connections on the circuit board, and broken wire at the connectors.

**(1) In case of SV1 (Bypass valve)**

This solenoid valve opens when powered (Relay ON).

- 1) This valve turns on during defrost, and its operation can be verified on the LED or by the operation sound it makes when it closes.
- 2) The open or closed status of the valve can be verified by measuring the temperature of the pipe at the downstream of SV1. When the valve is closed, pipes will be hot. Do not touch the pipe to check its temperature.

#### -4- LEV1W(a,b)

##### LEV1W(a,b) operation

LEV1W(a,b) are stepping-motor-driven valves that operate by receiving the pulse signals from the indoor and outdoor unit control boards.

##### (1) LEV

The valve opening changes according to the number of pulses.

##### 1) Indoor and outdoor unit control boards and the LEV (Indoor unit: Linear expansion valve)

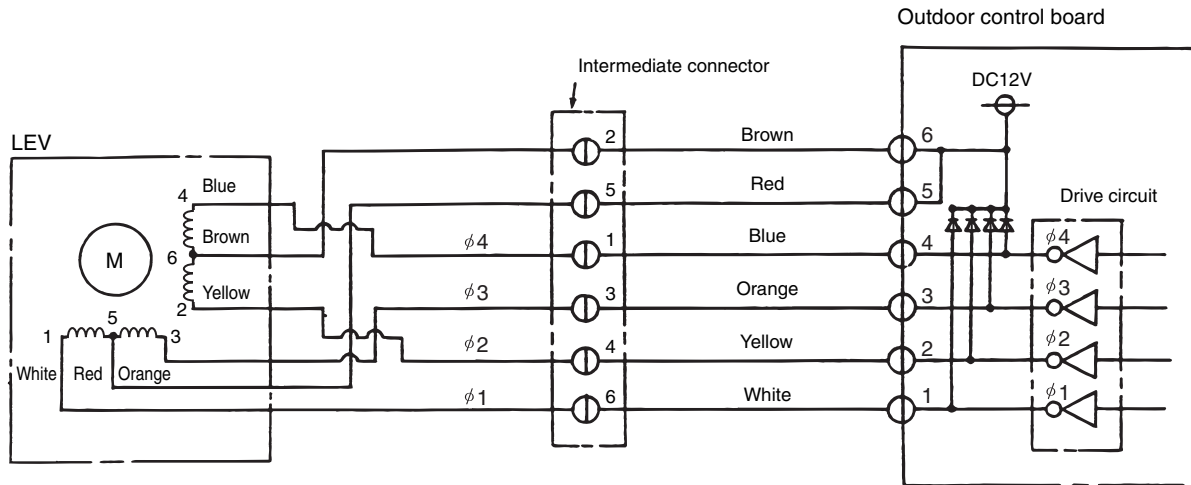

Note. The connector numbers on the intermediate connector and the connector on the control board differ. Check the color of the lead wire to judge the number.

##### 2) Pulse signal output and valve operation

Output (phase) number	Output state			
	1	2	3	4
$\phi 1$	ON	OFF	OFF	ON
$\phi 2$	ON	ON	OFF	OFF
$\phi 3$	OFF	ON	ON	OFF
$\phi 4$	OFF	OFF	ON	ON

Output pulses change in the following orders when the  
 Valve is closed; 1 → 2 → 3 → 4 → 1  
 Valve is open; 4 → 3 → 2 → 1 → 4

- \*1. When the LEV opening angle does not change, all the output phases will be off.
- \*2. When the output is open phase or remains ON, the motor cannot run smoothly, and rattles and vibrates.

##### 3) LEV valve closing and opening operation

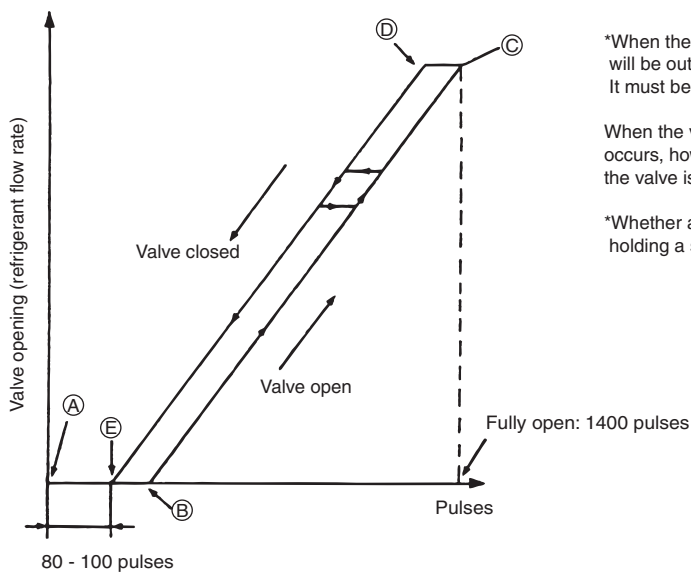

\*When the power is turned on, the valve closing signal of 2200 pulses will be output from the indoor board to LEV to fix the valve position. It must be fixed at point (A).

When the valve operates smoothly, no sound from LEV or no vibration occurs, however, when the pulses change from (E) to (A) in the chart or the valve is locked, a big sound occurs.

\*Whether a sound is generated or not can be determined by holding a screwdriver against it, then placing your ear against the handle.

**(2) Judgment methods and possible failure mode**

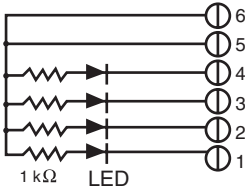
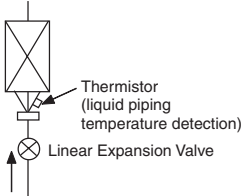
Malfunction mode	Judgment method	Remedy	Target LEV
Microcomputer driver circuit failure	<p>Disconnect the control board connector and connect the check LED as shown in the figure below.</p>  <p>resistance : 0.25W 1kΩ LED : DC15V 20mA or more</p> <p>When the main power is turned on, the indoor unit circuit board outputs pulse signals to the indoor unit LEV for 10 seconds, and the outdoor unit circuit board outputs pulse signals to the outdoor unit LEV for 17 seconds.</p> <p>If any of the LED remains lit or unlit, the drive circuit is faulty.</p>	When the drive circuit has a problem, replace the control board.	BU AU
LEV mechanism is locked	If the LEV is locked, the drive motor runs idle, and makes a small clicking sound. When the valve makes a closing and opening sound, the valve has a problem.	Replace the LEV.	BU AU
Disconnected or short-circuited LEV motor coil	Measure resistance between the coils (red - white, red -orange, brown - yellow, brown - blue) using a tester. They are normal if resistance is 150ohm $\pm$ 10%.	Replace the LEV coils.	BU AU
	Measure resistance between the coils (red - white, red -orange, brown - yellow, brown - blue) using a tester. They are normal if resistance is 46ohm $\pm$ 3%.	Replace the LEV coils.	BU AU
Incomplete sealing (leak from the valve)	<p>To check the LEV for leakage, stop the unit in question, and operate the other units in the cooling mode. Next, check the temperature of the unit liquid pipe (TH22) on the service LED. When the unit is stopped, the LEV is fully closed, so unless there is a leak, the pipe temperature will not go down. If the liquid pipe temperature is considerably lower than the water temperature reading on the remote controller, it indicates a valve closure failure. (The LEV is not sealed properly.) If the amount of leakage is insignificant and does not have negative effects, the valve does not need to be replaced.</p> 	If there is a large amount of leakage, replace the LEV.	AU
Faulty wire connections in the connector or faulty contact	<ol style="list-style-type: none"> <li>1. Check for loose pins on the connector and check the colors of the lead wires visually</li> <li>2. Disconnect the control board's connector and conduct a continuity check using a tester.</li> </ol>	Check the continuity at the points where an error occurs.	BU AU

### (3) LEV coil removal procedure

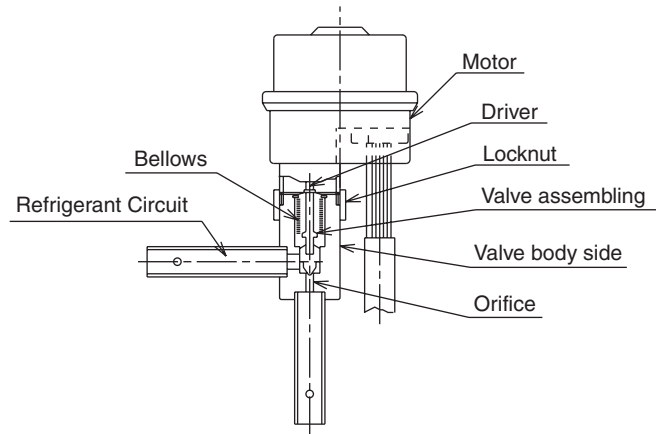

#### Notes on the procedure

- 1) Do not put undue pressure on the motor.
- 2) Do not use motors if dropped.
- 3) Do not remove the cap until immediately before the procedure.
- 4) Do not wipe off any molybdenum.
- 5) Do not remove the packing.
- 6) Do not apply any other than specified liquid such as screw lock agent, grease and etc.

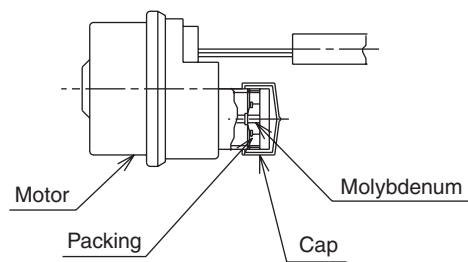

### Replacement procedure

- 1) Stop all the indoor and outdoor units. Check that all the units are stopped, and turn off the power to the outdoor unit.
- 2) Prepare two spanners. Hold the valve body with one spanner and loosen the locknut with another one.  
Turning the locknut counter-clockwise from motor side view can loosen it.  
Two spanners must be used.  
Do not hold the motor with one hand and loosen the locknut with only one spanner.
- 3) Turning the locknut several times. The locknut will come off and then the motor can be removed.
- 4) Prepare a motor replacement. Use only factory settings, which the head part of the driver does not come out. **Use of other than factory settings may result in malfunction and failure of valve flow rate control.**
- 5) Keep dust, contaminants, and water out of the space between the motor and the valve body during replacement. (The space is the mechanical section of the valve.) Do not damage the junction with tools.  
After removing the motor, **blow N<sub>2</sub> gas or etc. into bellows in order to blow off water from inside.**
- 6) Remove the cap of the motor replacement. Joint the axis of the motor and the one of the valve body with the locknut to stick precisely. **Apply screw lock agent to whole part of the screw. Do not introduce screw lock agent into the motor.**  
**Use new motors if problems are found on the motor during the replacement.**
- 7) After rotating the locknut 2~3 times by hands, hold the valve body with the spanner, and tighten the locknut with the specified torque with a torque wrench. Apply the tightening torque of 15N · m (150kgf · cm) (administration value 15 ± 1 N · m (150 ± 10kgf · cm)).  
Note that undue tightening may cause breaking a flare nut.
- 8) When tightening the locknut, hold the motor with hands so that undue rotary torque and load can not be applied.
- 9) The differences of relative position after assembling the motor and the valve body do not affect the valve control and the switching function.  
Do not relocate the motor and the valve body after tightening the locknut. Even the relative position is different from before and after assembling.

Difference in rotational direction is acceptable.

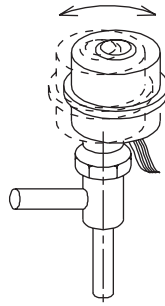

The motor may not be fixed with clamp because of the changing of the motor configuration. However, the fixing is not necessary due to the pipe fixing.

- 10) Connect the connector. Do not pull hard on the lead wire. Make sure that the connector is securely inserted into the specified position, and check that the connector does not come off easily.
- 11) Turn on the indoor unit, and operate the air conditioner. Check that no problems are found.

#### (4) LEV2W

The valve opening changes according to the number of pulses.

##### 1) Connections between the control board and LEV2W

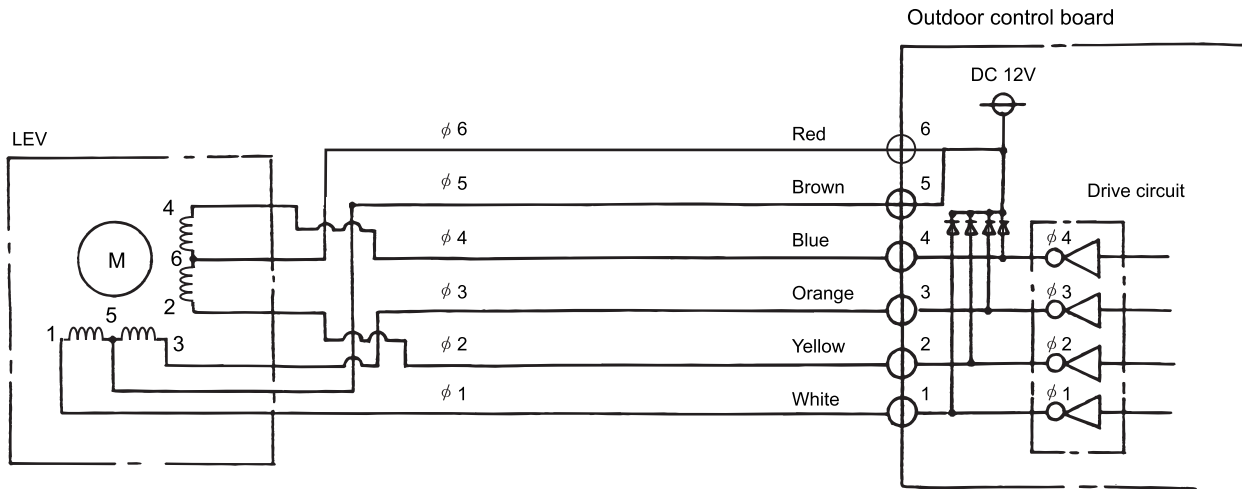

##### 2) Pulse signal output and valve operation

Output (phase) number	Output state							
	1	2	3	4	5	6	7	8
$\phi 1$	ON	OFF	OFF	OFF	OFF	OFF	ON	ON
$\phi 2$	ON	ON	ON	OFF	OFF	OFF	OFF	OFF
$\phi 3$	OFF	OFF	ON	ON	ON	OFF	OFF	OFF
$\phi 4$	OFF	OFF	OFF	OFF	ON	ON	ON	OFF

Output pulses change in the following orders when the

Valve is open; 1 → 2 → 3 → 4 → 5 → 6 → 7 → 8 → 1

Valve is closed; 8 → 7 → 6 → 5 → 4 → 3 → 2 → 1 → 8

\*1. When the LEV opening angle does not change, all the output phases will be off.

\*2. When the output is open phase or remains ON, the motor cannot run smoothly, and rattles and vibrates.

##### 3) LEV valve closing and opening operation

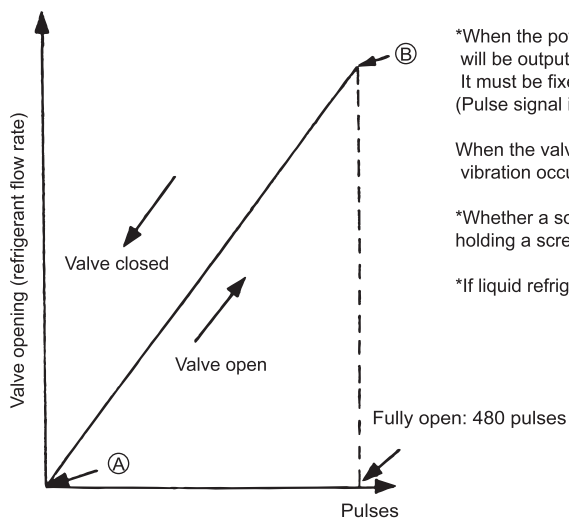

\*When the power is turned on, the valve closing signal of 520 pulses will be output from the indoor board to LEV to fix the valve position. It must be fixed at point (A). (Pulse signal is output for approximately 17 seconds.)

When the valve operates smoothly, there is no sound from the LEV and no vibration occurs, but when the valve is locked, noise is generated.

\*Whether a sound is generated or not can be determined by holding a screwdriver against it, then placing your ear against the handle.

\*If liquid refrigerant flows inside the LEV, the sound may become smaller.

**(5) LEV (LEV2W) coil removal procedure**

1) LEV component

As shown in the figure, the outdoor LEV is made in such a way that the coils and the body can be separated.

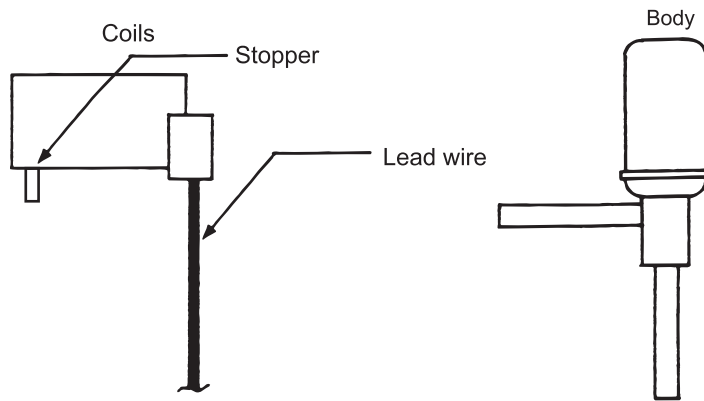

2) Removing the coils

Fasten the body tightly at the bottom (Part A in the figure) so that the body will not move, then pull out the coils toward the top. If the coils are pulled out without the body gripped, undue force will be applied and the pipe will be bent.

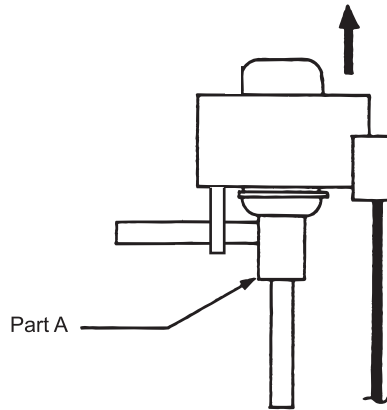

3) Installing the coils

Fix the body tightly at the bottom (Part A in the figure) so that the body will not move, then insert the coils from the top, and insert the coil stopper securely in the pipe on the body. Hold the body when pulling out the coils to prevent so that the pipe will not be bent.

If the coils are pushed without the body gripped, undue force will be applied and the pipe will be bent. Hold the body when pulling out the coils to prevent so that the pipe will not be bent.

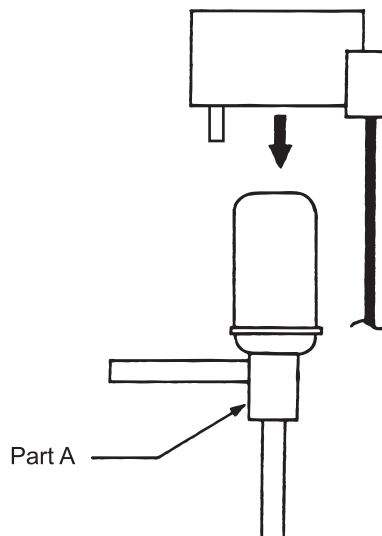



## -5- Inverter

- ♦ Replace only the compressor if only the compressor is found to be defective.
- ♦ Replace the defective components if the inverter is found to be defective.
- ♦ If both the compressor and the inverter are found to be defective, replace the defective component(s) of both devices.

### (1) Inverter-related problems: Troubleshooting and remedies

- 1) The inverter board has a large-capacity electrolytic capacitor, in which residual voltage remains even after the main power is turned off, posing a risk of electric shock. Before inspecting the inside of the control box, turn off the power, leave the unit turned off for at least 10 minutes, and check that the voltage between the pins of CN631 has dropped to 20V or less. (It takes about 10 minutes to discharge electricity after the power supply is turn off.)
- 2) If cables are not inserted properly to the Faston terminals or connectors are not connected properly, inverter parts will be damaged. If a problem occurs after replacing some of the parts, mixed up wiring is often the cause of the problem. Check for proper connection of the wiring, screws, connectors, and Faston terminals.
- 3) To avoid damage to the circuit board, do not connect or disconnect the inverter-related connectors with the main power turned on.
- 4) Faston terminals have a locking function. Make sure the terminals are securely locked in place after insertion. Press the tab in the middle of the terminals to remove them.

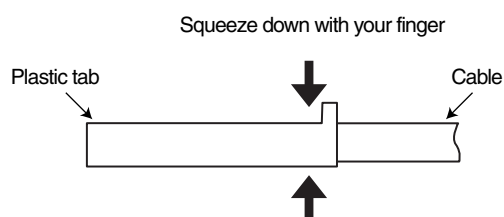

- 5) When replacing the INV (inverter) board, apply a thin layer of grease (supplied with the service parts) evenly to the radiation plate. Wipe off any grease that may get on the wiring terminal to avoid terminal contact failure.
- 6) Faulty wiring to the compressor damages the compressor. Connect the wiring in the correct phase sequence.

	Error display/failure condition	Measure/inspection item
[1]	Inverter related errors 4102, 4115, 4220, 4230, 4250, 5110, 5301, 0403	Check the details of the inverter error in the error log at [10]. [1] LED Monitor Display. Take appropriate measures to the error code and the error details in accordance with [9]. [1] Check Code List
[2]	Main power breaker trip	Refer to "(3) Trouble treatment when the main power breaker is tripped".(page 73)
[3]	Main power earth leakage breaker trip	Refer to "(4) Trouble treatment when the main power earth leakage breaker is tripped".(page 73)
[4]	Only the compressor does not operate.	Check the inverter frequency on the LED monitor and proceed to (2) - [4] if the compressor is in operation.(page 72)
[5]	The compressor vibrates violently at all times or makes an abnormal sound.	See (2)-[4].(page 72)
[6]	Noise is picked up by the peripheral device	<p>&lt;1&gt; Check that power supply wiring of the peripheral device does not run close to the power supply wiring of the outdoor unit.</p> <p>&lt;2&gt; Check if the inverter output wiring is not running parallel to the power supply wiring and the transmission lines.</p> <p>&lt;3&gt; Check that the shielded wire is used as the transmission line when it is required, and check that the grounding work is performed properly on the shielded wire.</p> <p>&lt;4&gt; Meg failure for electrical system other than the inverter</p> <p>&lt;5&gt; Attach a ferrite core to the inverter output wiring. (Contact the factory for details of the service part settings.)</p> <p>&lt;6&gt; Provide separate power supply to the air conditioner and other electric appliances.</p> <p>&lt;7&gt; If the error occurred suddenly, a ground fault of the inverter output can be considered. See (2)-[4].(page 72)</p> <p>*Contact the factory for cases other than those listed above.</p>
[7]	Sudden malfunction (as a result of external noise.)	<p>&lt;1&gt; Check that the grounding work is performed properly.</p> <p>&lt;2&gt; Check that the shielded wire is used as the transmission line when it is required, and check that the grounding work is performed properly on the shielded wire.</p> <p>&lt;3&gt; Check that neither the transmission line nor the external connection wiring does not run close to another power supply system or does not run through the same conduit pipe.</p> <p>* Contact the factory for cases other than those listed above.</p>

**(2) Inverter output related troubles**

	Items to be checked	Phenomena	Remedy
[1] Check the INV board error detection circuit.	(1) Terminals on the inverter board Remove the inverter output cable from U, V, and W terminals.	1) Overcurrent error (4250 Detail code No. 101, 102)	Replace the INV board.
	(2) Operate the units.	2) Converter-related errors (4220 Detail code No. 01, 108, 109, 121)	Replace the INV board.
		3) ACCT sensor circuit failure (5300 Detail code No.115)	Replace the INV board.
		4) IPM open (5300 Detail code No. [-] None)	Normal
		5) Power-supply-related problems occur. Error code : 4115, 4102 Detail code : 01, [-] None	Replace the INV board.
[2] Check for compressor ground fault or coil error.	Disconnect the compressor wiring, and check the compressor Meg, and coil resistance.	1) Compressor Meg failure Error if less than 1 Mohm.	Check that there is no liquid refrigerant in the compressor. If there is none, replace the compressor.
		2) Compressor coil resistance failure Coil resistance value of 1 ohm (20°C [68°F]): BU, AU	Replace the compressor.
[3] Check whether the inverter is damaged. (No load)	(1) Remove the inverter output cable from U, V, and W-W terminals.	1) Inverter-related problems are detected.	Turn SW5-1 to OFF, and see item "1."
	(2) Turn SW5-1 on the control board to ON.	2) Inverter voltage is not output at the terminals	Replace the INV board.
	(3) Operate the units. Check the inverter output voltage after the inverter output frequency has stabilized.	3) There is a voltage imbalance between the wires. Greater than 5% imbalance or 5V	Replace the INV board.
		4) There is no voltage imbalance between the wires.	Normal *Turn SW5-1 to OFF.
[4] Check whether the inverter is damaged. (During compressor operation)	Operate the units. Check the inverter output voltage after the inverter output frequency has stabilized.	1) There is a voltage imbalance between the wires. Greater than 5% imbalance or 5V	Replace the INV board.

**(3) Trouble treatment when the main power breaker is tripped**

	Items to be checked	Phenomena	Remedy
[1]	Check the breaker capacity.	Use of a non-specified breaker	Replace it with a specified breaker.
[2]	Perform Meg check between the terminals on the power terminal block TB1.	Zero to several ohm, or Meg failure	Check each part and wiring. *Refer to (5) "Simple checking procedures for individual components of main inverter circuit".(page 74)
[3]	Turn on the power again and check again.	1) Main power breaker trip 2) No remote control display	•INV board •Noise filter board •AC reactor
[4]	Turn on the outdoor unit and check that it operates normally.	1) Operates normally without tripping the main breaker. 2) Main power breaker trip	a) The wiring may have been short-circuited. Search for the wire that short-circuited, and repair it. b) If item a) above is not the cause of the problem, refer to (2)-[1].

**(4) Trouble treatment when the main power earth leakage breaker is tripped**

	Items to be checked	Phenomena	Remedy
[1]	Check the earth leakage breaker capacity and the sensitivity current.	Use of a non-specified earth leakage breaker	Replace with a regulation earth leakage breaker.
[2]	Check the resistance at the power supply terminal block (TB1) with a megger.	Failure resistance value	Check each part and wiring. *Refer to (5) "Simple checking procedures for individual components of main inverter circuit".(page 74) •INV board •Noise filter board •AC reactor
[3]	Disconnect the compressor wirings and check the resistance of the compressor with a megger.	Failure compressor if the insulating resistance value is not in specified range. Failure when the insulating resistance value is 1 Mohm or less.	Check that there is no liquid refrigerant in the compressor. If there is none, replace the compressor.

**Note**

The insulation resistance could go down to close to 1Mohm after installation or when the power is kept off for an extended period of time because of the accumulation of refrigerant in the compressor. If the earth leakage breaker is triggered, please use the following procedure to take care of this.

- Disconnect the wires from the compressor's terminal block.
- If the resistance is less than 1 Mohm, switch on the power for the outdoor unit with the wires still disconnected.
- Leave the power on for at least 12 hours.
- Check that the resistance has recovered to 1 Mohm or greater.

**Earth leakage current measurement method**

- For easy on-site measurement of the earth leakage current, enable the filter with a measurement instrument that has filter functions as below, clamp all the power supply wires, and measure.  
Recommended measurement instrument: CLAMP ON LEAK HiTESTER 3283 made by HIOKI E.E. CORPORATION
- When measuring one device alone, measure near the device's power supply terminal block.

**(5) Simple checking procedure for individual components of main inverter circuit**

**Note**

Leave the power turned off for 10 minutes, check that the voltage between pins 1 and 3 of CN631 on the control board is 20V or below, and remove the circuit board or the parts from the control box. When any problem is found with the circuit board or other parts, replace them.

Part name	Judgment method									
INV board	See " Inverter output related troubles "( 9 [3] - 5 - (2) )(page 72)									
Noise filter board (Inrush current limiting resistor)	Measure the resistance between terminal RS: 20 ohm $\pm$ 10%									
Noise filter board (Electromagnetic relay 52C)	<p>This electromagnetic relay is rated at DC12V and is driven by a coil. Check the resistance between terminals (52C on the noise filter board)</p> <table border="1"> <thead> <tr> <th>Parts</th> <th>Checkpoints</th> <th>Criterion value</th> </tr> </thead> <tbody> <tr> <td>Coil</td> <td>Between pins 1 and 2 of CN52C</td> <td>Not to be short-circuited (Center value 16 ohm)</td> </tr> <tr> <td>Contact</td> <td>Both ends of RS</td> <td>20 ohm <math>\pm</math> 10%</td> </tr> </tbody> </table>	Parts	Checkpoints	Criterion value	Coil	Between pins 1 and 2 of CN52C	Not to be short-circuited (Center value 16 ohm)	Contact	Both ends of RS	20 ohm $\pm$ 10%
Parts	Checkpoints	Criterion value								
Coil	Between pins 1 and 2 of CN52C	Not to be short-circuited (Center value 16 ohm)								
Contact	Both ends of RS	20 ohm $\pm$ 10%								
DC reactor ACL	<p>Measure the resistance between terminals: 1ohm or lower (almost 0 ohm)</p> <p>Measure the resistance between terminals and the chassis: <math>\infty</math></p>									

## [4] Maintenance

- Section 1 Recovering and charging refrigerant from the R134a side  
Before replacing the parts on PWFY-P100VM-E-BU (compressor, LEV, strainer (ST2), PHEX), be sure to take the following steps.

### [Recovering the refrigerant]

- Stop all indoor and outdoor units, and turn off all power supplies to the units.
  - Check that all indoor and outdoor units are stopped.
- Recover all refrigerant remaining inside the unit through the check joint.  
Do not release the extracted refrigerant into the atmosphere.

### [Charging refrigerant]

- Evacuate air from the unit through the check joint.  
Refer to section 1-[8] "Vacuum Drying" for detailed procedures.
- Charge 1.1 kg of R134a through the check joint.

Check the Service Manual that came with the outdoor unit for how to recover refrigerant from or charge refrigerant into the outdoor units.

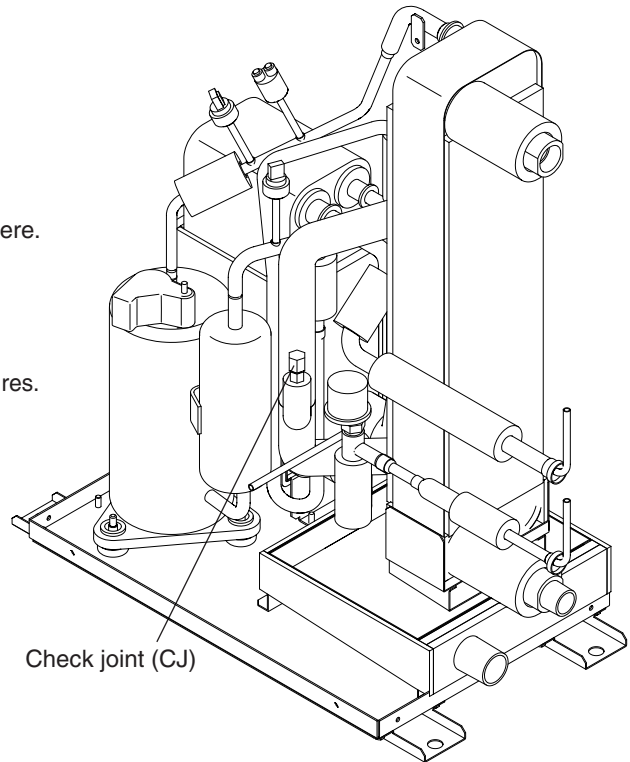

### [Cleaning the water strainer]

- Remove the caulking used to fill the space between the insulation material and the unit.
- Peel off the tape that is holding insulation material together.
- Remove the strainer, take the net out, and clean it with a brush.  
To remove the strainer, hold part A with a pipe wrench so that the strainer will not move, and loosen part B with a spanner.  
**Use two spanners to tighten or loosen the strainer.**
- When cleaning is finished, replace the parts in the reverse order as they were removed.

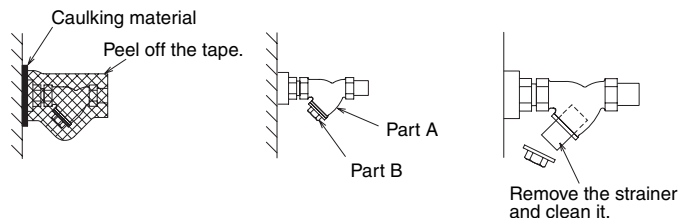

### [Replacing the strainer]

- Remove the caulking used to fill the space between the insulation material and the unit.
- Peel off the tape that is holding insulation material together.
- Hold part A with a spanner, and loosen part B with a spanner by turning it counterclockwise, and remove the strainer.  
**Use two spanners to tighten or loosen the strainer.**
- Replace the parts in the reverse order as they were removed.

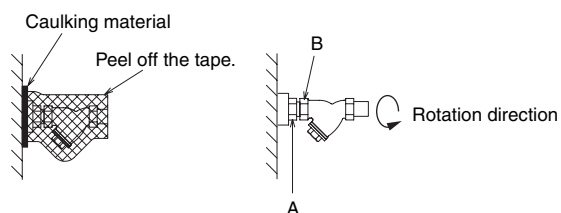

**[Replacing the parts on PWFY-P100VM-E-BU]**

Recover the refrigerant before replacing the parts.  
Refer to section 1 "Recovering the refrigerant"  
for how to recover the refrigerant.

1. Stop all indoor and outdoor units, and turn off all power supplies to the units.
  - 1) Check that all indoor and outdoor units are stopped.
2. Recover all refrigerant remaining inside the unit through the check joint.  
Do not release the extracted refrigerant into the atmosphere.

**[Replacing the compressor]**

1. Debraze the parts on the pipe that are marked with an arrow, and replace the compressor.
2. After replacement is complete, securely connect the cables, and place the cover (A) back on.

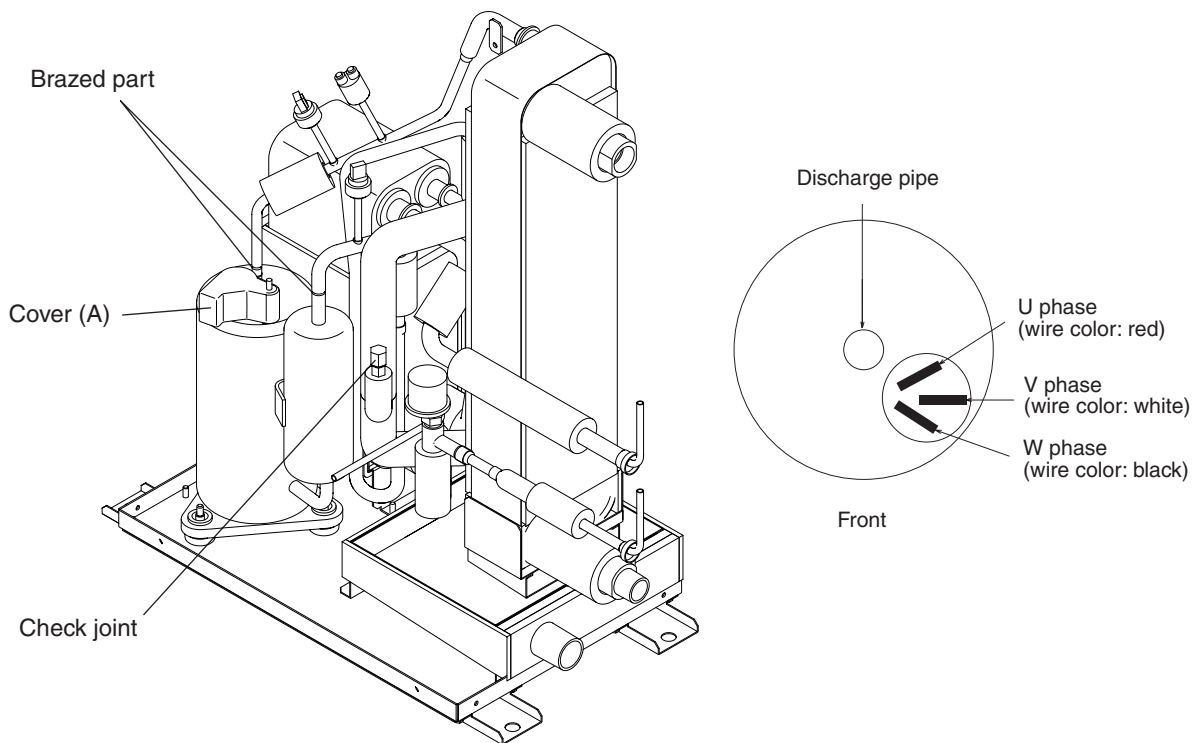

**[Replacing the LEV]**

Replacing LEV1

1. Debraze the parts on the pipe that are indicated in the figure, and replace LEV1.
2. Connect the connector to CNLVC on the circuit board.

In the case of PWFY-P200VM-E/E1/E2-AU, connect the connectors to CNLVB and CNLVC on the circuit board.

Replacing LEV2

1. Debraze the parts on the pipe that are indicated in the figure, and replace LEV1.
2. Connect the connector to CNLVA on the circuit board after installation is complete.

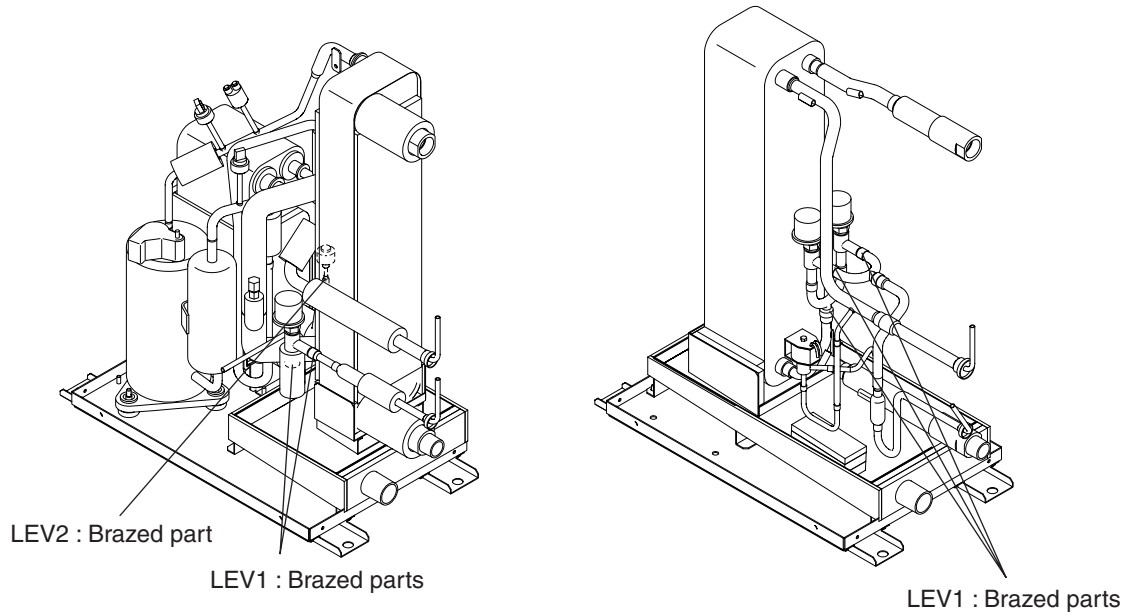

\*PWFY-P100VM-E/E1/E2-AU only has one LEV.

**[Replacing the heat exchanger]**

Replacing the refrigerant-refrigerant heat exchanger

1. Cut the part that is indicated in the figure.
2. Debraze the parts on the pipe that are indicated in the figure.
3. Rebraze the debrazed parts after replacement.

Replacing the water-refrigerant heat exchanger

1. Debraze the parts on the pipe that are indicated in the figure.
2. Rebraze the debrazed parts after replacement.

Refrigerant-refrigerant heat exchanger

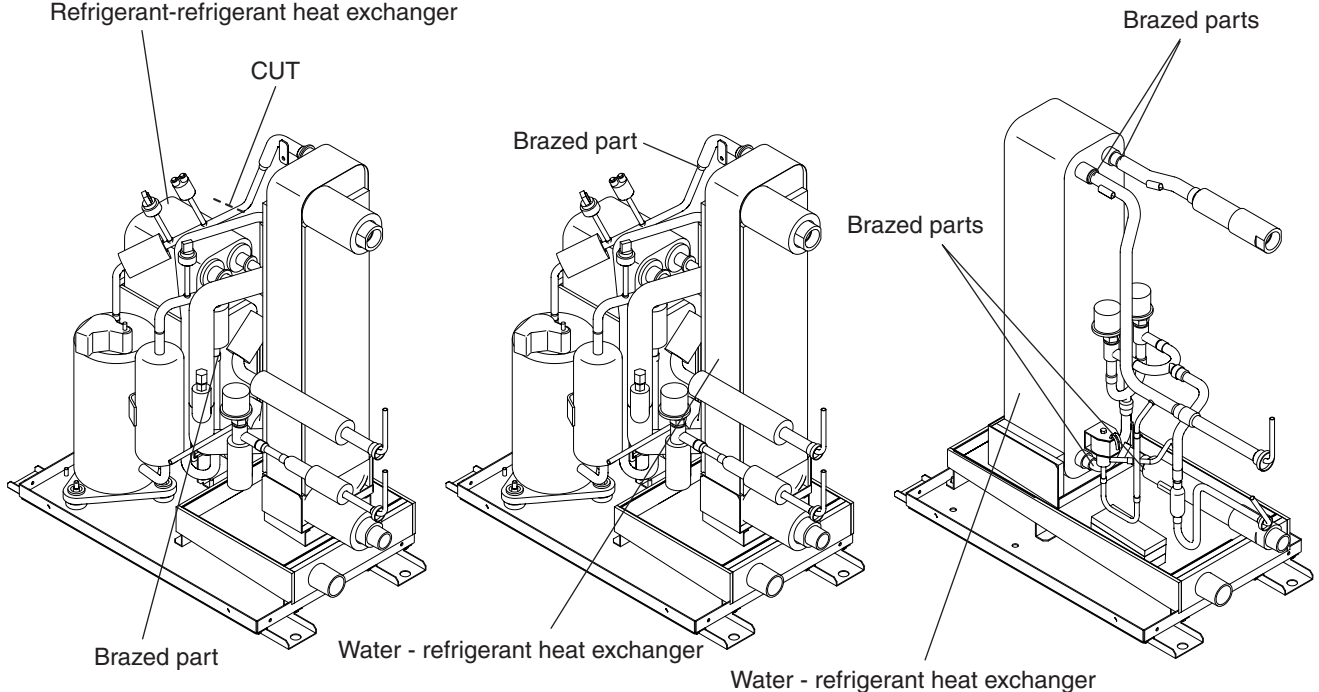

\*Common to PWFY-P100/P200VM-E/E1/E2-AU



**[Replacing the strainer]**

1. Debraze the parts on the pipe that are indicated in the figure.
2. Rebraze the debrazed parts after replacement.

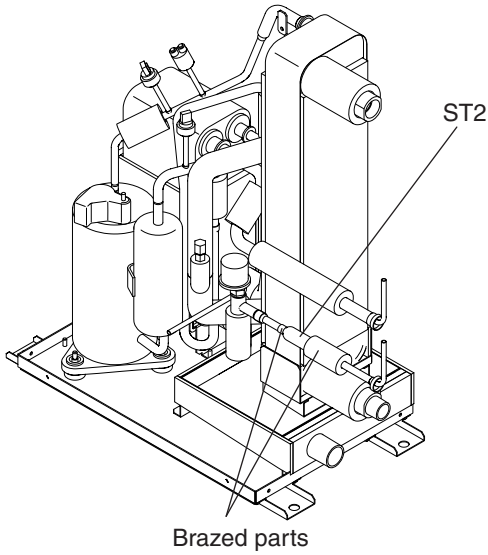

**[Replacing the solenoid valve]**

1. Unscrew the screws.
2. Debraze the parts on the pipe that are indicated in the figure.
3. Rebraze the debrazed parts after replacement.
4. Connect the connector to CN502 on the circuit board.

<PWFY-P100/P200VM-E/E1-AU>

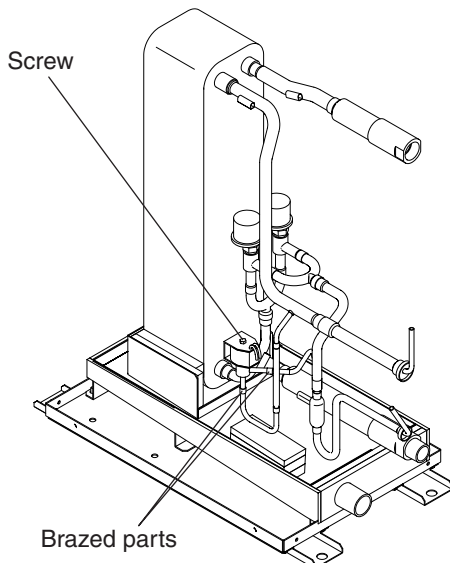

<PWFY-P100/P200VM-E2-AU>

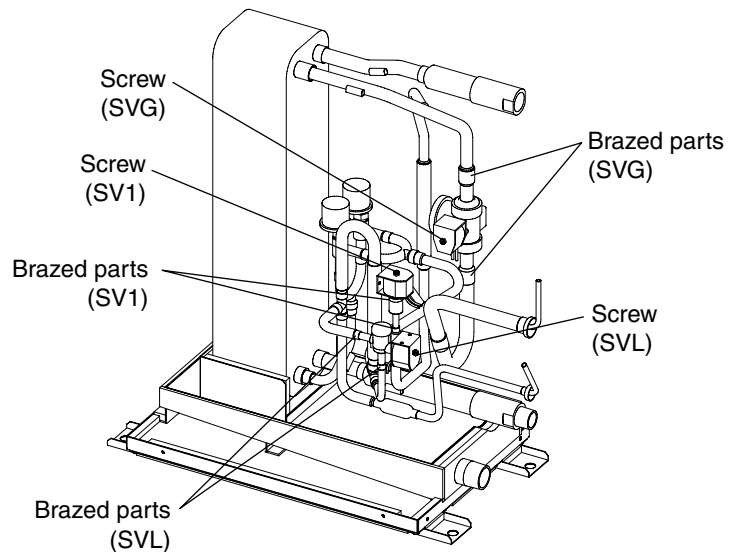

\*Common to PWFY-P100/P200VM-E1/E2-AU

**[Replacing the check valve]**

1. Debraze the parts on the pipe that are indicated in the figure.
2. Rebraze the debrazed parts after replacement.

<PWFY-P100/P200VM-E/E1-AU>

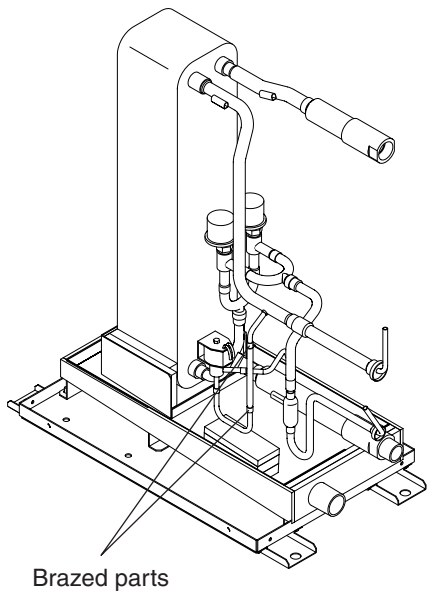

<PWFY-P100/P200VM-E2-AU>

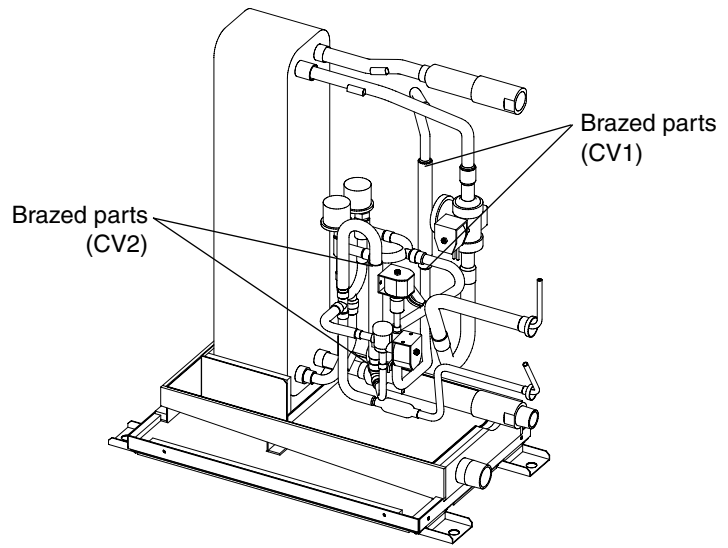

**[Replacing the strainer ST3, ST4]**

1. Debraze the parts on the pipe that are indicated in the figure.
2. Rebraze the debrazed parts after replacement.

<PWFY-P100/P200VM-E/E1-AU>

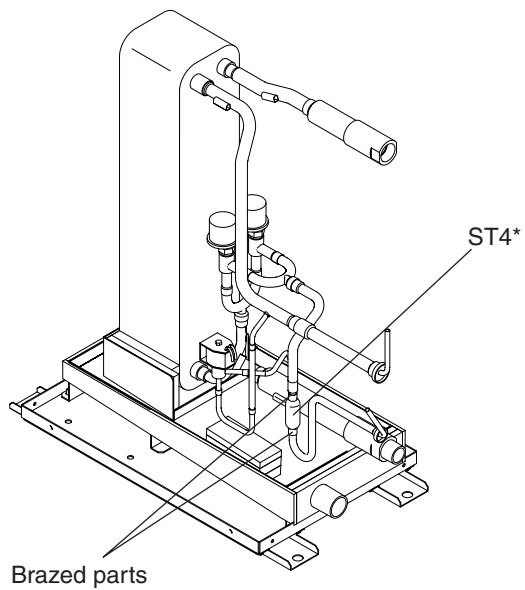

<PWFY-P100/P200VM-E2-AU>

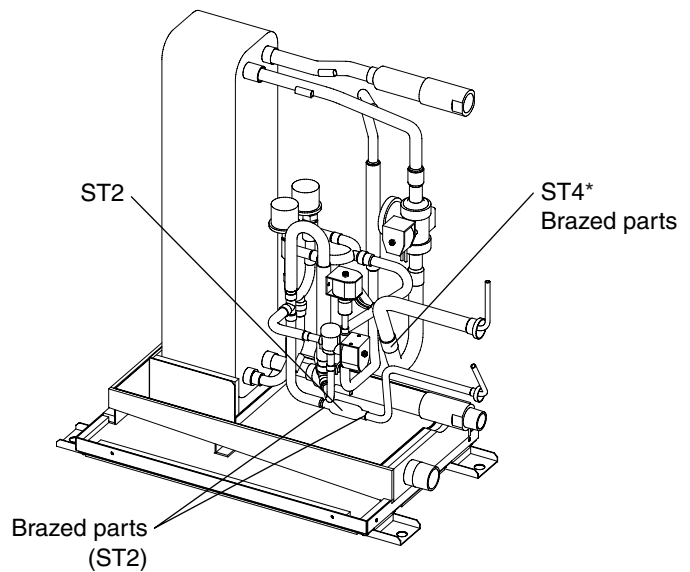

\*ST3 in the case of P100VM-E/E1/E2-AU

## 10 LED display

### [1] LED Monitor Display

#### 1. How to Read the LED on the Service Monitor

##### (1) How to read the LED

By setting the DIP SW 2-1 through 2-10 (Switch number 10 is represented by 0), the operating condition of the unit can be monitored on the service monitor. (Refer to the table on the following pages for DIP SW settings.)  
The service monitor uses 4-digit 7-segment LED to display numerical values and other types of information.

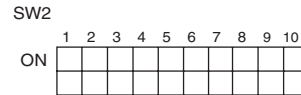
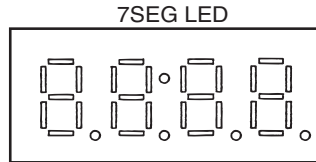

SW1-10 is represented as "0" in the table.

Pressure and temperature are examples of numerical values, and operating conditions and the on-off status of solenoid valve are examples of flag display.

##### 1) Display of numerical values

Example: When the pressure data sensor reads 18.8kg/cm<sup>2</sup> (Item No. 55)

- The unit of pressure is in kg/cm<sup>2</sup>
- Use the following conversion formula to convert the displayed value into a value in SI unit.

$$\text{Value in SI unit (MPa)} = \text{Displayed value (kg/cm}^2\text{)} \times 0.098$$

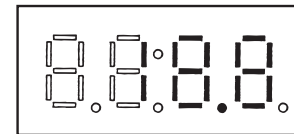

##### 2) Flag display

Example: Pump interlock

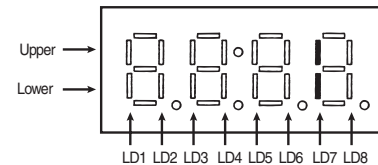

##### (2) LED display at initial setting

From power on until the completion of initial settings, the following information will be displayed on the monitor screen. (Displays No. 1 through No. 4 in order repeatedly.)

No	Item	Display	Remarks
1	Software version	0104	[0104] : Version 1.04
2	Refrigerant type	[ 134]	[ 134] : R134A
3	Model and capacity	A08	[A-04] : PWFY-P100VM-E-AU [A-08] : PWFY-P200VM-E-AU [b-04] : PWFY-P100VM-E-BU
4	Communication address	01	[ 01] : Address 1

After the initial settings have been completed, the information on these items can be checked by making the switch setting that corresponds to No. 261 in the LED display table.

##### Note

Only item No. 1 "Software Version" appears on the display if there is a wiring failure between the control board and the transmission line power supply board or if the circuit board has failed.

### (3) Time data storage function

If an error (including a preliminary error) occurs, the error history data and the error detection time are stored into the service memory.

The error detection time stored in the service memory and the current time can be seen on the service LED.

**Note**

- 1) Use the time displayed on the service LED as a reference.
- 2) The date and the time are set to "00" by default.
- 3) The time is not updated while the power of the indoor unit is turned off. When the power is turned off and then on again, the count will resume from the time before the power was turned off. Thus, the time that differs the actual time will be displayed. (This also applies when a power failure occurs.)

#### (3)-1 Reading the time data:

- 1) Time display

Example: 12 past 9

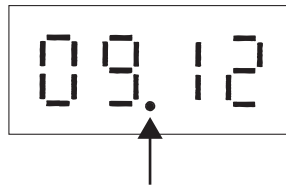

\* Disappears if the time data is deviated due to a power failure, or if a system controller that sets the time is not connected.

- 2) Date display

•When the main controller that can set the time is connected

Example: May 10, 2003

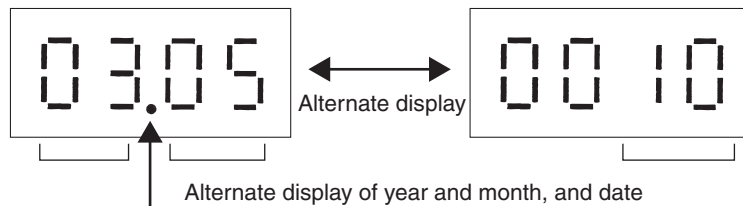

Alternate display of year and month, and date

\* Appears between the year and the month, and nothing appears when the date is displayed.

•When the main controller that can set the time is not connected

Example: 52 days after power was turned on

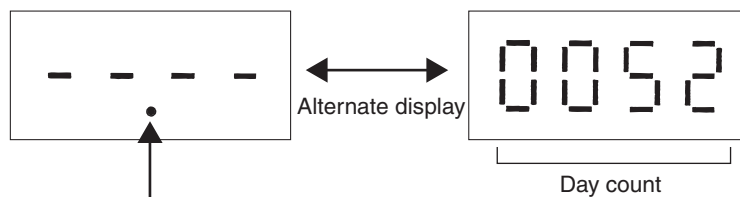

\* Appears between the year and the month, and nothing appears when the date is displayed.

## LED monitor display

### Current data

No.	SW1 1234567890	Item	Display								Remarks	
			LD1	LD2	LD3	LD4	LD5	LD6	LD7	LD8		
0	0000000000	Relay output display 1 Lighting	Comp in operation		SV1			52C		BU	CPU in operation	
		Error code display 1 BU/WH error	0000 to 9999									
1	1000000000	Error code display 2 Preliminary BU/WH error	0000 to 9999 (Address and error codes highlighted)								Display of the latest preliminary error If no preliminary errors are detected, "----" appears on the display.	
2	0100000000											
3	1100000000											
4	0010000000											
5	1010000000											
6	0110000000	Preset temperature	-99.9 to 999.9									
7	1110000000											
8	0001000000	TH0	Inlet	Outlet								
9	1001000000	Communication demand capacity	0000 to 9999								If not demanded controlled, "----" [ % ] appears on the display.	
10	0101000000	Contact point demand capacity	0000 to 9999								If not demanded controlled, "----" [ % ] appears on the display.	
11	1101000000	External signal	Contact point demand							Pump interlock (Contact: open)		
12	0011000000	External signal										
13	1011000000											
14	0111000000	Operation status			3-minutes re-start mode	Compressor in operation	Preliminary error	Error		3-minutes re-start after instantaneous power failure		
15	1111000000											
16	0000100000											

**Current data**

No.	SW1	Item	Display								Remarks
			LD1	LD2	LD3	LD4	LD5	LD6	LD7	LD8	
17	1000100000										
18	0100100000										
19	1100100000										
20	0010100000										
21	1010100000										
22	0110100000										
23	1110100000										
24	0001100000										
25	1001100000										
26	0101100000										
27	1101100000										
28	0011100000										
29	1011100000										
30	0111100000										
31	1111100000										
32	0000010000										
33	1000010000										
34	0100010000										
35	1100010000										
36	0010010000										
37	1010010000	Operation mode	Cooling ON	Cooling OFF	Heating ON	Heating OFF					Stop
38	0110010000		Hot Water	Heating	Heating ECO	Anti-freeze	Cooling				
39	1110010000	BC controller operation mode	Permit	Standby	Prohibit	Defrost					
40	0001010000										
41	1001010000										
42	0101010000	Control mode	Stop		Abnormal stop	Scheduled control	Defrost	High frequency oil recovery	Low frequency oil recovery		

**Current data**

No.	SW1	Item	Display								Remarks	
			LD1	LD2 Refrigerant re-covery	LD3 Anti-freeze	LD4 Power failure	LD5 Test-run mode	LD6	LD7	LD8		
43	1101010000	Control mod										
44	0011010000											
45	1011010000	TH11				-99.9 to 999.9						The unit is [°C]
46	0111010000	TH13/TH23				-99.9 to 999.9						
47	1111010000	TH22				-99.9 to 999.9						
48	0000110000	TH6				-99.9 to 999.9						
49	1000110000	TH8				-99.9 to 999.9						
50	0100110000											
51	1100110000											
52	0010110000											
53	1010110000	THHS1				-99.9 to 999.9						The unit is [°C]
54	0110110000											
55	1110110000	High-pressure sensor data				-99.9 to 999.9						The unit is [kgf/cm <sup>2</sup> ]
56	0001110000	Low-pressure sensor data				-99.9 to 999.9						
57	1001110000											
58	0101110000	LEV1				0000 to 9999						
59	1101110000	LEV2				0 to 480						LEV opening (Fully open : 480)
60	0011110000											
61	1011110000											
62	0111110000	COMP control frequency				0000 to 9999						The unit is [rps]
63	1111110000	COMP output frequency				0000 to 9999						Compressor operating frequency (*1) The unit is [rps]
64	0000001000	COMP 1 primary current				-99.9 to 999.9						The unit is [A rms]
65	1000001000	COMP operating current				-99.9 to 999.9						The unit is [A rms]

\*1 Output frequency of the inverter depends on the type of compressor and equals the integer multiples of the operating frequency of the compressor.

**Current data**

No.	SW1	Item	Display								Remarks
			LD1	LD2	LD3	LD4	LD5	LD6	LD7	LD8	
66	0100001000	COMP bus voltage	0000 to 9999								The unit is [ V ]
67	1100001000										
68	0010001000										
69	1010001000										
70	0110001000										
71	1110001000	Tc	-99.9 to 999.9								
72	0001001000	Te	-99.9 to 999.9								
73	1001001000										
74	0101001000	Target SH	-99.9 to 999.9								The unit is [ °C ]
75	1101001000	Target SC	-99.9 to 999.9								
76	0011001000	SH	-99.9 to 999.9								
77	1011001000	SC	-99.9 to 999.9								
78	0111001000	Td*	-99.9 to 999.9								
79	1111001000	Upper 4 digits of COMP operation time	0000 to 9999								The unit is [ h ]
80	0000101000	Lower 4 digits of COMP operation time	0000 to 9999								
81	1000101000	Upper 4 digits of the number of COMP start-stops	0000 to 9999								
82	0100101000	Lower 4 digits of the number of COMP start-stops	0000 to 9999								
83	1100101000	Upper 4 digits of operation time (excluding stoppage time)	0000 to 9999								
84	0010101000	Lower 4 digits of operation time (excluding stoppage time)	0000 to 9999								Circulating water replacement indicator timer
85	1010101000	Backup	High-pressure rise		Low-pressure drop		Td rise				
86	0110101000										
87	1110101000										



**Current data**

No.	SW1	Item	Display								Remarks	
	1234567890		LD1	LD2	LD3	LD4	LD5	LD6	LD7	LD8		
88	0001101000											
89	1001101000											
90	0101101000											
91	1101101000											
92	0011101000											
93	1011101000											
94	0111101000											
95	1111101000											
96	0000011000											
97	1000011000											
98	0100011000											
99	1100011000											
100	0010011000											
101	1010011000											
102	0110011000											
103	1110011000											
104	0001011000											
105	1001011000											
106	0101011000											
107	1101011000											
108	0011011000											
109	1011011000											
110	0111011000											
111	1111011000											
112	0000111000											
113	1000111000											
114	0100111000											
115	1100111000											
116	0010111000											

**Current data**

No.	SW1	Item	Display								Remarks	
			LD1	LD2	LD3	LD4	LD5	LD6	LD7	LD8		
117	1234567890											
118	1010111000											
119	0110111000											
120	1110111000											
121	0001111000											
122	1001111000											
123	0101111000											
124	1101111000											
125	0011111000											
126	1011111000											
127	0111111000											
128	1111111000											
129	000000100											
129	100000100											
130	010000100											
131	110000100											
132	001000100											
133	101000100											
134	011000100											
135	111000100											
136	0001000100											
137	1001000100											
138	0101000100											
139	1101000100											
140	0011000100											
141	1011000100											
142	0111000100											
143	1111000100											
144	0000100100											
145	1000100100											

**Current data**

No.	SW1	Item	Display								Remarks	
	1234567890		LD1	LD2	LD3	LD4	LD5	LD6	LD7	LD8		
146	0100100100											
147	1100100100											
148	0010100100											
149	1010100100											
150	0110100100											
151	1110100100											
152	0001100100											
153	1001100100											
154	0101100100											
155	1101100100											
156	0011100100											
157	1011100100											
158	0111100100											
159	1111100100											
160	0000010100											
161	1000010100											
162	0100010100											
163	1100010100											
164	0010010100											
165	1010010100											
166	0110010100											
167	1110010100											
168	0001010100											
169	1001010100											
170	0101010100											
171	1101010100											
172	0011010100											
173	1011010100											
174	0111010100											

**Current data**

No.	SW1	Item	Display								Remarks	
	1234567890		LD1	LD2	LD3	LD4	LD5	LD6	LD7	LD8		
175	1111010100											
176	0000110100											
177	1000110100											

**Error history**

No.	SW1	Item	Display								Remarks	
			LD1	LD2	LD3	LD4	LD5	LD6	LD7	LD8		
178	0100110100	Error history 1				0000 to 9999						Address and error codes highlighted If no errors are detected, "----" appears on the display.
179	1100110100	Error details of inverter				Error details of inverter (0001-0120)						
180	0010110100	Error history 2				0000 to 9999						
181	1010110100	Error details of inverter				Error details of inverter (0001-0120)						
182	0110110100	Error history 3				0000 to 9999						
183	1110110100	Error details of inverter				Error details of inverter (0001-0120)						
184	0001110100	Error history 4				0000 to 9999						
185	1001110100	Error details of inverter				Error details of inverter (0001-0120)						
186	0101110100	Error history 5				0000 to 9999						
187	1101110100	Error details of inverter				Error details of inverter (0001-0120)						
188	0011110100	Error history 6				0000 to 9999						
189	1011110100	Error details of inverter				Error details of inverter (0001-0120)						
190	0111110100	Error history 7				0000 to 9999						
191	1111110100	Error details of inverter				Error details of inverter (0001-0120)						
192	000001100	Error history 8				0000 to 9999						
193	100001100	Error details of inverter				Error details of inverter (0001-0120)						
194	010001100	Error history 9				0000 to 9999						
195	110001100	Error details of inverter				Error details of inverter (0001-0120)						
196	0010001100	Error history 10				0000 to 9999						
197	1010001100	Error details of inverter				Error details of inverter (0001-0120)						
198	0110001100	Error history of inverter (At the time of last data backup before error)				0000 to 9999						
199	1110001100	Error details of inverter				Error details of inverter (0001-0120)						
200	0001001100											

Data before error

No.	SW1	Item	Display								Remarks
			LD1	LD2	LD3	LD4	LD5	LD6	LD7	LD8	
201	1001001100	Operation status	BC operation signal		3-minutes re-start mode	Compressor in operation	Preliminary error	Error	3-minutes re-start after instantaneous power failure	Preliminary/low pressure error	Items No. 201 through No. 255 indicate abnormal unit stoppage or preliminary error data.
202	0101001100										
203	1101001100	Operation mode	Cooling ON	Cooling OFF	Heating ON	Heating OFF				Stop	
204	0011001100		Hot Water	Heating	Heating ECO	Anti-freeze	Cooling				
205	1011001100	BC controller operation mode	Permit	Standby	Prohibit	Defrost					
206	0111001100										
207	1111001100										
208	0000101100	Control mode	Stop		Abnormal stop	Scheduled control		Defrost	High frequency oil recovery	Low frequency oil recovery	
209	1000101100			Refrigerant recovery	Anti-freeze	Power failure	Test-run mode				
210	0100101100										
211	1100101100	Relay output display 1 Lighting	Comp in operation		SV1	52C			BU	Always lit	
212	0010101100										
213	1010101100										
214	0110101100										
215	1110101100	Preset temperature									
216	0001101100	TH11									The unit is [°C]
217	1001101100	TH13/TH23									
218	0101101100	TH22									
219	1101101100	TH6									
220	0011101100	TH8									
221	1011101100										
222	0111101100										
223	1111101100										

Data before error

No.	SW1	Item	Display								Remarks		
			LD1	LD2	LD3	LD4	LD5	LD6	LD7	LD8			
224	0000011100	THHS1											
225	1000011100												
226	0100011100	High-pressure sensor data											The unit is [kgf/cm <sup>2</sup> ]
227	1100011100	Low-pressure sensor data											
228	0010011100												
229	1010011100	LEV1											
230	0110011100	LEV2											LEV opening (Fully open : 480)
231	1110011100												
232	0001011100												
233	1001011100	COMP control frequency											The unit is [ rps]
234	0101011100	COMP output frequency											Compressor operating frequency The unit is [ rps]
235	1101011100	COMP 1 primary current											The unit is [ Arms]
236	0011011100	COMP operating current											The unit is [ Arms]
237	1011011100	COMP bus voltage											The unit is [ V]
238	0111011100												
239	1111011100												
240	0000111100												
241	1000111100												
242	0100111100	Tc											
243	1100111100	Te											
244	0010111100												
245	1010111100	Target SH											The unit is [°C]
246	0110111100	Target SC											
247	1110111100	SH											

Data before error

No.	SW1		Item	Display								Remarks		
	1234567890	000111100		LD1	LD2	LD3	LD4	LD5	LD6	LD7	LD8			
248	000111100		SC											
249	100111100													
250	010111100		Upper 4 digits of COMP operation time											The unit is [ h ]
251	110111100		Lower 4 digits of COMP operation time											
252	001111100		Upper 4 digits of the number of COMP start-stops											
253	101111100		Lower 4 digits of the number of COMP start-stops											
254	011111100													
255	111111100													
256	000000010		Unit address											
257	100000010													
258	010000010		RC address											
259	110000010		BC address											
260	001000010													
261	101000010		Version / capacity											
262	011000010		OC address											
263	111000010													
264	000100010													
265	100100010		INV version 1											
266	010100010													
267	110100010													
268	001100010													
269	101100010													
270	011100010													
271	111100010													
272	000010010													



Data before error

No.	SW1	Item	Display								Remarks	
	1234567890		LD1	LD2	LD3	LD4	LD5	LD6	LD7	LD8		
273	1000100010											
274	0100100010											
275	1100100010											
276	0010100010											
277	1010100010											
278	0110100010											
279	1110100010											
280	0001100010											
281	1001100010											
282	0101100010											
283	1101100010											
284	0011100010											
285	1011100010											
286	0111100010											
287	1111100010											
288	0000010010											
289	1000010010											
290	0100010010											
291	1100010010											
292	0010010010											
293	1010010010											
294	0110010010											
295	1110010010											
296	0001010010											
297	1001010010											
298	0101010010											
299	1101010010											
300	0011010010											

**Current data**

No.	SW1	Item	Display								Remarks	
			LD1	LD2	LD3	LD4	LD5	LD6	LD7	LD8		
301	1234567890											
302	1011010010											
303	0111010010											
304	1111010010											
305	0000110010											
306	1000110010											
307	0100110010											
308	1100110010											
309	0010110010											
310	1010110010											
311	0110110010											
312	1110110010											
313	0001110010											
314	1001110010											
315	0101110010											
316	1101110010											
317	0011110010											
318	1011110010											
319	0111110010											
320	1111110010											
321	0000001010											
322	1000001010											
323	0100001010											
324	1100001010											
325	0010001010											
326	1010001010											
327	0110001010											
328	1110001010											
329	0001001010											
329	1001001010											

**Current data**

No.	SW1	Item	Display								Remarks	
	1234567890		LD1	LD2	LD3	LD4	LD5	LD6	LD7	LD8		
330	0101001010											
331	1101001010											
332	0011001010											
333	1011001010											
334	0111001010											
335	1111001010											
336	0000101010											
337	1000101010											
338	0100101010											
339	1100101010											
340	0010101010											
341	1010101010											
342	0110101010											
343	1110101010											
344	0001101010											
345	1001101010											
346	0101101010											
347	1101101010											
348	0011101010											
349	1011101010											
350	0111101010											

Data on indoor unit system

No.	SW1	Item	Display								Remarks	
	1234567890		LD1	LD2	LD3	LD4	LD5	LD6	LD7	LD8		
351	1111101010											
352	0000011010											
353	1000011010											
354	0100011010											
355	1100011010											
356	0010011010											
357	1010011010											
358	0110011010											
359	1110011010											
360	0001011010											
361	1001011010											
362	0101011010											
363	1101011010											
364	0011011010											
365	1011011010											
366	0111011010											
367	1111011010											
368	0000111010											
369	1000111010											
370	0100111010											
371	1100111010											
372	0010111010											
373	1010111010											
374	0110111010											
375	1110111010											
376	0001111010											
377	1001111010											
378	0101111010											

Data on indoor unit system

No.	SW1	Item	Display								Remarks
	1234567890		LD1	LD2	LD3	LD4	LD5	LD6	LD7	LD8	
379	1101111010										
380	0011111010										
381	1011111010										
382	0111111010										
383	1111111010										
384	000000110										
385	100000110										
386	010000110										
387	110000110										
388	001000110										
389	101000110										
390	011000110										
391	111000110										
392	000100110										
393	100100110										
394	010100110										
395	110100110										
396	001100110										
397	101100110										
398	011100110										
399	111100110										
400	0000100110										
401	1000100110										
402	0100100110										
403	1100100110										
404	0010100110										
405	1010100110										
406	0110100110										
407	1110100110										

Data on indoor unit system

No.	SW1	Item	Display								Remarks	
	1234567890		LD1	LD2	LD3	LD4	LD5	LD6	LD7	LD8		
408	0001100110											
409	1001100110											
410	0101100110											
411	1101100110											
412	0011100110											
413	1011100110											
414	0111100110											
415	1111100110											
416	0000010110											
417	1000010110											
418	0100010110											
419	1100010110											
420	0010010110											
421	1010010110											
422	0110010110											
423	1110010110											
424	0001010110											
425	1001010110											
426	0101010110											
427	1101010110											
428	0011010110											
429	1011010110											
430	0111010110											
431	1111010110											
432	0000110110	Current time								00:00 to 23:59		Hour: minute
433	1000110110	Current time -2								00.00 to 99.12/1 to 31		Year and month, and date alternate display
434	0100110110	Time of error detection 1								00:00 to 23:59		Hour: minute

**Data on indoor unit system**

No.	SW1	Item	Display								Remarks
			LD1	LD2	LD3	LD4	LD5	LD6	LD7	LD8	
435	1100110110	Time of error detection 1-2				00.00 to 99.12/1 to 31					Year and month, and date alternate display
436	0010110110	Time of error detection 2				00:00 to 23:59					Hour: minute
437	1010110110	Time of error detection 2-2				00.00 to 99.12/1 to 31					Year and month, and date alternate display
438	0110110110	Time of error detection 3				00:00 to 23:59					Hour: minute
439	1110110110	Time of error detection 3-2				00.00 to 99.12/1 to 31					Year and month, and date alternate display
440	0001110110	Time of error detection 4				00:00 to 23:59					Hour: minute
441	1001110110	Time of error detection 4-2				00.00 to 99.12/1 to 31					Year and month, and date alternate display
442	0101110110	Time of error detection 5				00:00 to 23:59					Hour: minute
443	1101110110	Time of error detection 5-2				00.00 to 99.12/1 to 31					Year and month, and date alternate display
444	0011110110	Time of error detection 6				00:00 to 23:59					Hour: minute
445	1011110110	Time of error detection 6-2				00.00 to 99.12/1 to 31					Year and month, and date alternate display
446	0111110110	Time of error detection 7				00:00 to 23:59					Hour: minute
447	1111110110	Time of error detection 7-2				00.00 to 99.12/1 to 31					Year and month, and date alternate display
448	0000001110	Time of error detection 8				00:00 to 23:59					Hour: minute
449	1000001110	Time of error detection 8-2				00.00 to 99.12/1 to 31					Year and month, and date alternate display
450	0100001110	Time of error detection 9				00:00 to 23:59					Hour: minute
451	1100001110	Time of error detection 9-2				00.00 to 99.12/1 to 31					Year and month, and date alternate display
452	0010001110	Time of error detection 10				00:00 to 23:59					Hour: minute
453	1010001110	Time of error detection 10-2				00.00 to 99.12/1 to 31					Year and month, and date alternate display
454	0110001110	Time of last data backup before error				00:00 to 23:59					Hour: minute
455	1110001110	Time of last data backup before error -2				00.00 to 99.12/1 to 31					Year and month, and date alternate display
456	0001001110										

**Data on indoor unit system**

No.	SW1	Item								Display								Remarks			
	1234567890	LD1	LD2	LD3	LD4	LD5	LD6	LD7	LD8	LD9	LD10	LD11	LD12	LD13	LD14	LD15	LD16		LD17	LD18	
457	1001001110																				
458	0101001110																				
459	1101001110																				
460	0011001110																				
461	1011001110																				
462	0111001110																				
463	1111001110																				
464	0000101110																				
465	1000101110																				
466	0100101110																				
467	1100101110																				
468	0010101110																				
469	1010101110																				
470	0110101110																				
471	1110101110																				
472	0001101110																				
473	1001101110																				
474	0101101110																				
475	1101101110																				
476	0011101110																				
477	1011101110																				
478	0111101110																				
479	1111101110																				
480	0000011110																				
481	1000011110																				
482	0100011110																				
483	1100011110																				
484	0010011110																				
485	1010011110																				



Data on indoor unit system

No.	SW1	Item	Display								Remarks	
			LD1	LD2	LD3	LD4	LD5	LD6	LD7	LD8		
486	0110011110											
487	1110011110	Control board WDT Reset counter							0 to 254			
488	0001011110	INV board 1 WDT Reset counter							0 to 254			
489	1001011110											
490	0101011110											
491	1101011110											
492	0011011110											
493	1011011110											
494	0111011110											
495	1111011110											
496	0000111110											
497	1000111110											
498	0100111110											
499	1100111110											
500	0010111110											
501	1010111110											
502	0110111110											
503	1110111110											
504	0001111110											
505	1001111110											
506	0101111110											
507	1101111110											
508	0011111110											
509	1011111110											
510	0111111110											
511	1111111110											

# Service Handbook

## Model

PWFY-P100VM-E-BU

PWFY-P100, P200VM-E-AU

PWFY-P100, P200VM-E1-AU

PWFY-P100, P200VM-E2-AU

**MITSUBISHI ELECTRIC CORPORATION**

<http://Global.MitsubishiElectric.com>