



CITY MULTI

Air-Conditioners For Building Application
OUTDOOR UNIT

PURY-WP-YJM-A (-BS)

CE

For use with R410A

INSTALLATION MANUAL

For safe and correct use, please read this installation manual thoroughly before installing the air-conditioner unit.

GB

[Fig. 6.0.1]

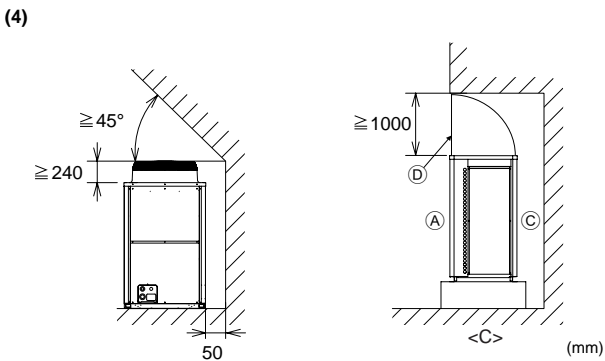
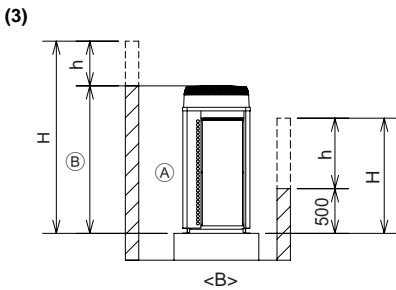
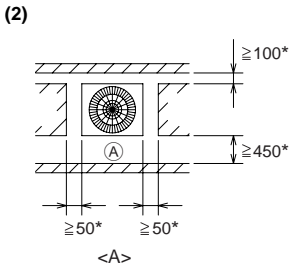
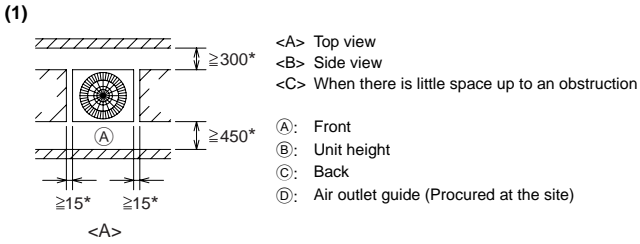

[Fig. 6.0.2]

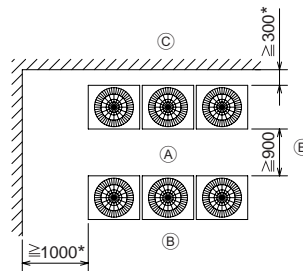
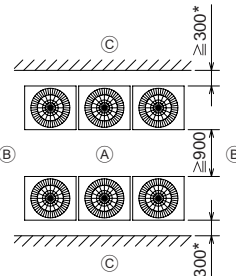
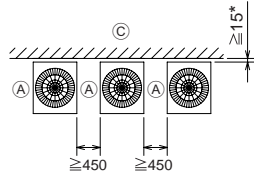
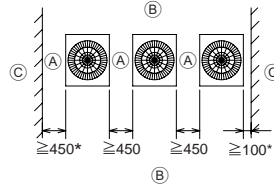
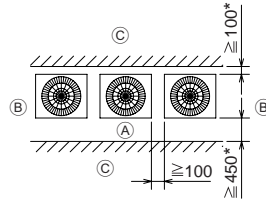
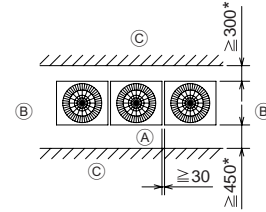

(A): Front
(B): Must be open
(C): Wall height (H)

(mm)

7

[Fig. 7.0.1]
WP200, WP250

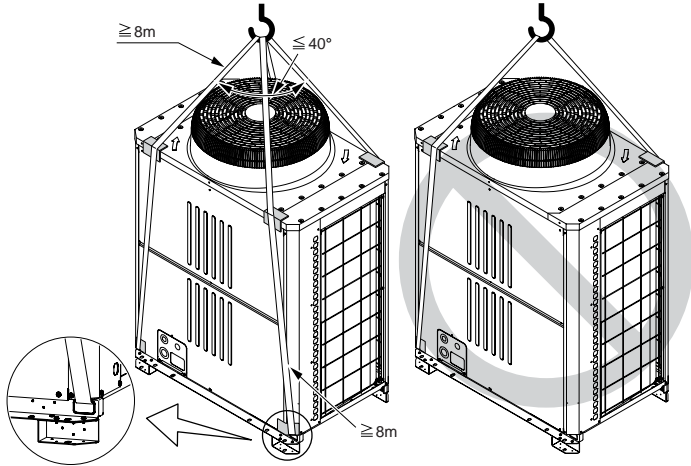

8

8.1

[Fig. 8.1.1]
<A> Without detachable leg

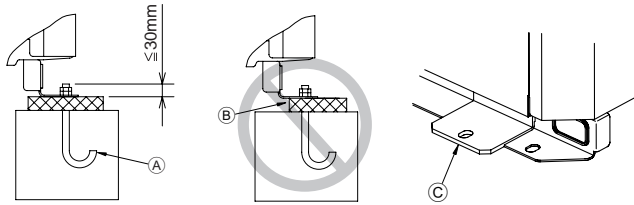

- Ⓐ: M10 anchor bolt procured at the site.
- Ⓑ: Corner is not seated.
- Ⓒ: Fixing bracket for hole-in anchor bolt (3 locations to fix with screws).
- Ⓓ: Detachable leg

 With detachable leg

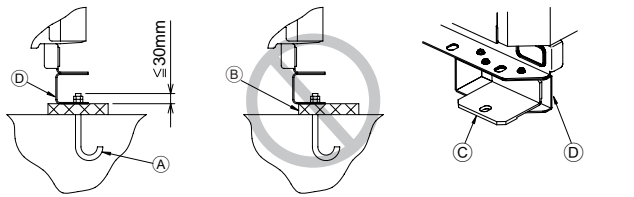

[Fig. 8.1.2]

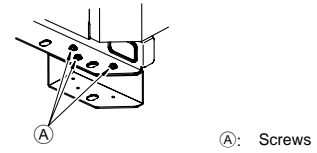

9

9.2

[Fig. 9.2.1]
[WP200, WP250YJM]

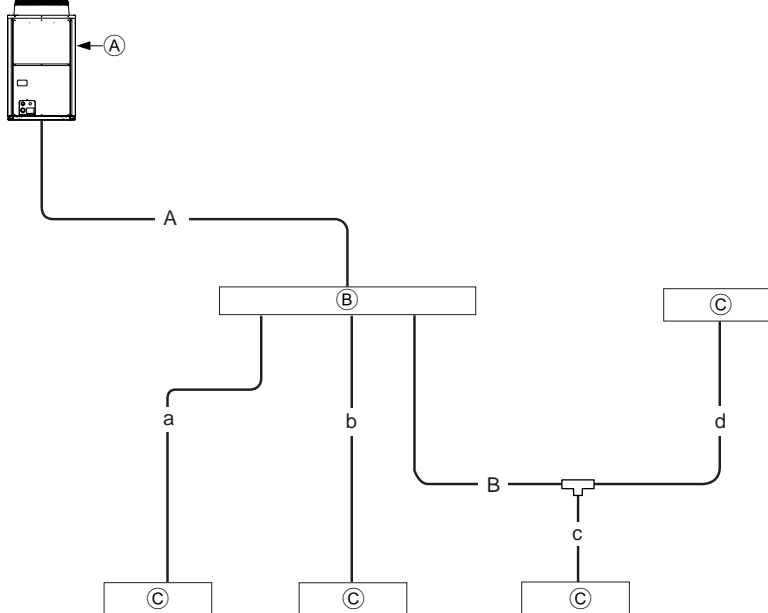

- Ⓐ: Outdoor unit
- Ⓑ: HBC controller
- Ⓒ: Indoor unit (20 ~ 50)

A [Standard] (mm)

A Outdoor model		A	
		B High-pressure side	C Low-pressure side
WP200	YJM-A	ø15.88	ø19.05
WP250	YJM-A	ø19.05	ø22.2

B (mm)

D Total capacity of indoor units	E Water out	F Water return
~ 80	I.D. 20	I.D. 20

a, b, c, d (mm)

G Model number	E Water out	F Water return
20, 25, 32, 40, 50	I.D. 20	I.D. 20

[Fig. 10.2.1]

<A> Refrigerant service valve (High-pressure side/brazed type)

 Refrigerant service valve (Low-pressure side/brazed type)

WP200, WP250

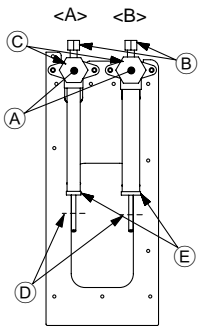

- A: Shaft
- B: Service port
- C: Cap
- D: Pinched connecting pipe severing portion
- E: Pinched connecting pipe brazing portion

[Fig. 10.2.3]

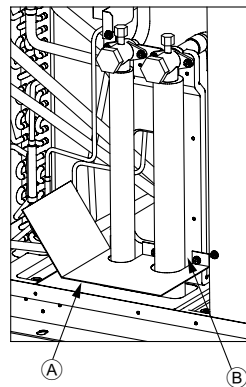

- A: Example of closure materials (field supply)
- B: Fill the gap at the site

[Fig. 10.2.2]

No.	①	②	③	④	⑤
(A) Shape					
WP200YJM	-	1 <C> Low-pressure side	1 <D> High-pressure side	1 <C> Low-pressure side	1 <D> High-pressure side
WP250YJM	1 <C> Low-pressure side	1 <D> High-pressure side	-	1 <D> High-pressure side	-

<A> Front pipe routing

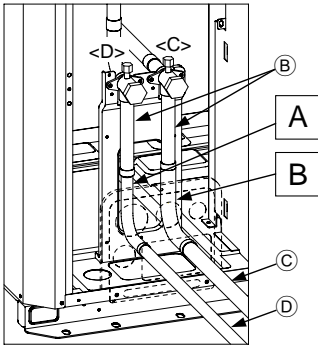

 Bottom pipe routing

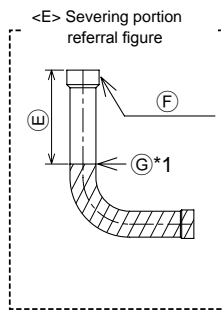
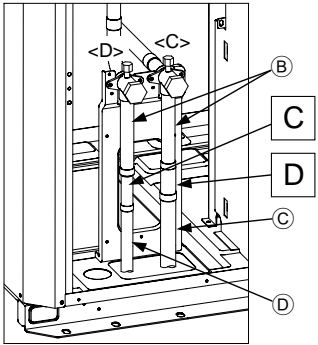

<A> Front pipe routing
<D> High-pressure side

 Bottom pipe routing
<E> Severing portion referral figure

<C> Low-pressure side

- (A): Shape
- (D): On-site piping (high-pressure connecting pipe)
- (G): Severing portion

- (B): Refrigerant service valve piping
- (E): 75 mm (reference measurement)

- (C): On-site piping (low-pressure connecting pipe)
- (F): ID ø25.4 side

*1 Use a pipe cutter to sever.

10.3

[Fig. 10.3.1]

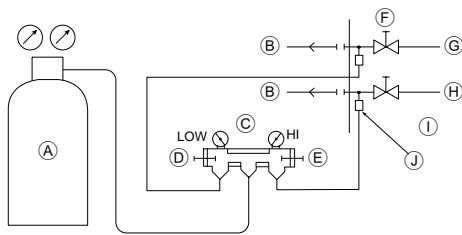

- (A): Nitrogen gas
- (B): To indoor unit
- (C): System analyzer
- (D): Low knob
- (E): Hi knob
- (F): Valve
- (G): Low-pressure pipe
- (H): High-pressure pipe
- (I): Outdoor unit
- (J): Service port

[Fig. 10.3.2]

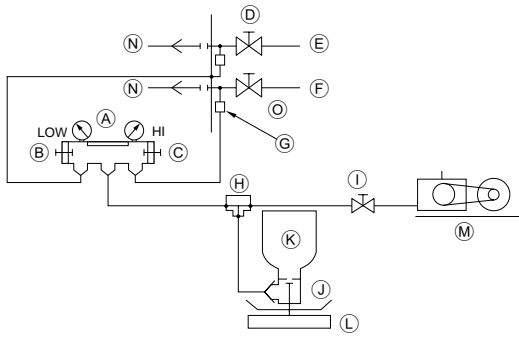

- (A): System analyzer
- (B): Low knob
- (C): Hi knob
- (D): Valve
- (E): Low-pressure pipe
- (F): High-pressure pipe
- (G): Service port
- (H): Three-way joint
- (I): Valve
- (J): Valve
- (K): R410A cylinder
- (L): Scale
- (M): Vacuum pump
- (N): To indoor unit
- (O): Outdoor unit

[Fig. 10.3.3]

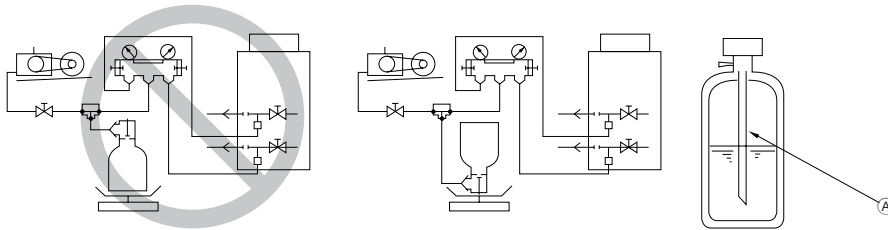

(B): In case of the R410A cylinder having no syphon pipe.

10.4

[Fig. 10.4.1]

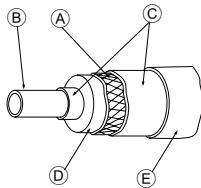

- (A): Steel wire
- (B): Piping
- (C): Asphaltic oily mastic or asphalt
- (D): Heat insulation material A
- (E): Outer covering B

[Fig. 10.4.2]

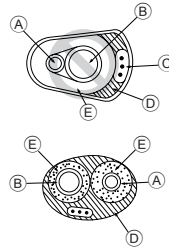

- (A): High-pressure pipe
- (B): Low-pressure pipe
- (C): Electric wire
- (D): Finishing tape
- (E): Insulator

[Fig. 10.4.3]

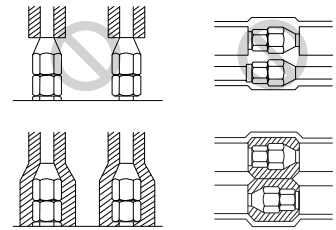

[Fig. 10.4.4]

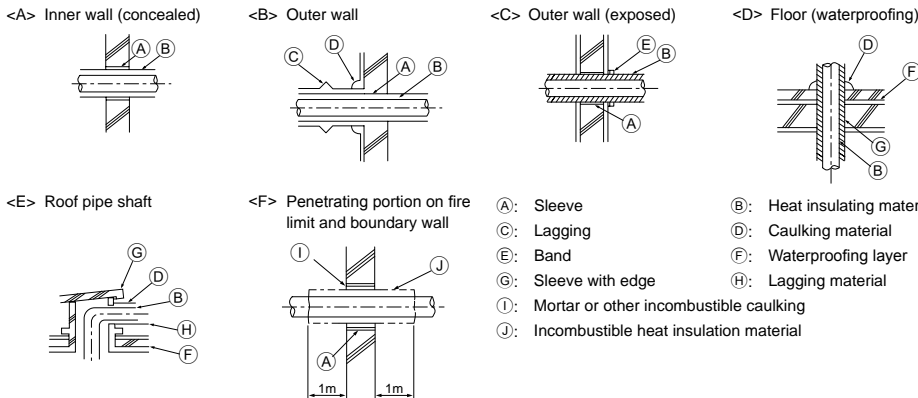

- (A): Sleeve
- (B): Heat insulating material
- (C): Lagging
- (D): Caulking material
- (E): Band
- (F): Waterproofing layer
- (G): Sleeve with edge
- (H): Lagging material
- (I): Mortar or other incombustible caulking
- (J): Incombustible heat insulation material

[Fig. 11.2.1]

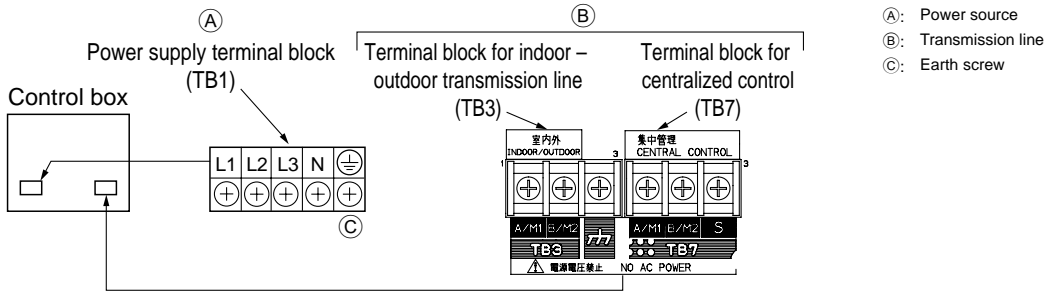

[Fig. 11.2.2]

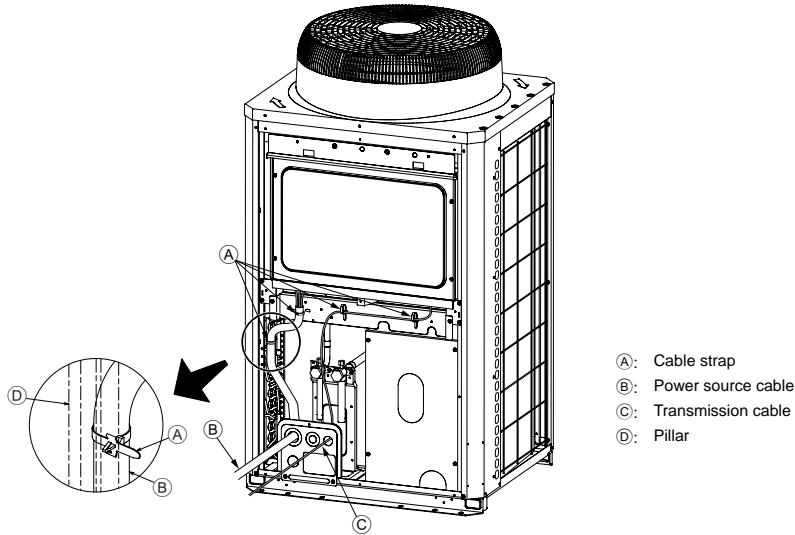

11.3

[Fig. 11.3.1]

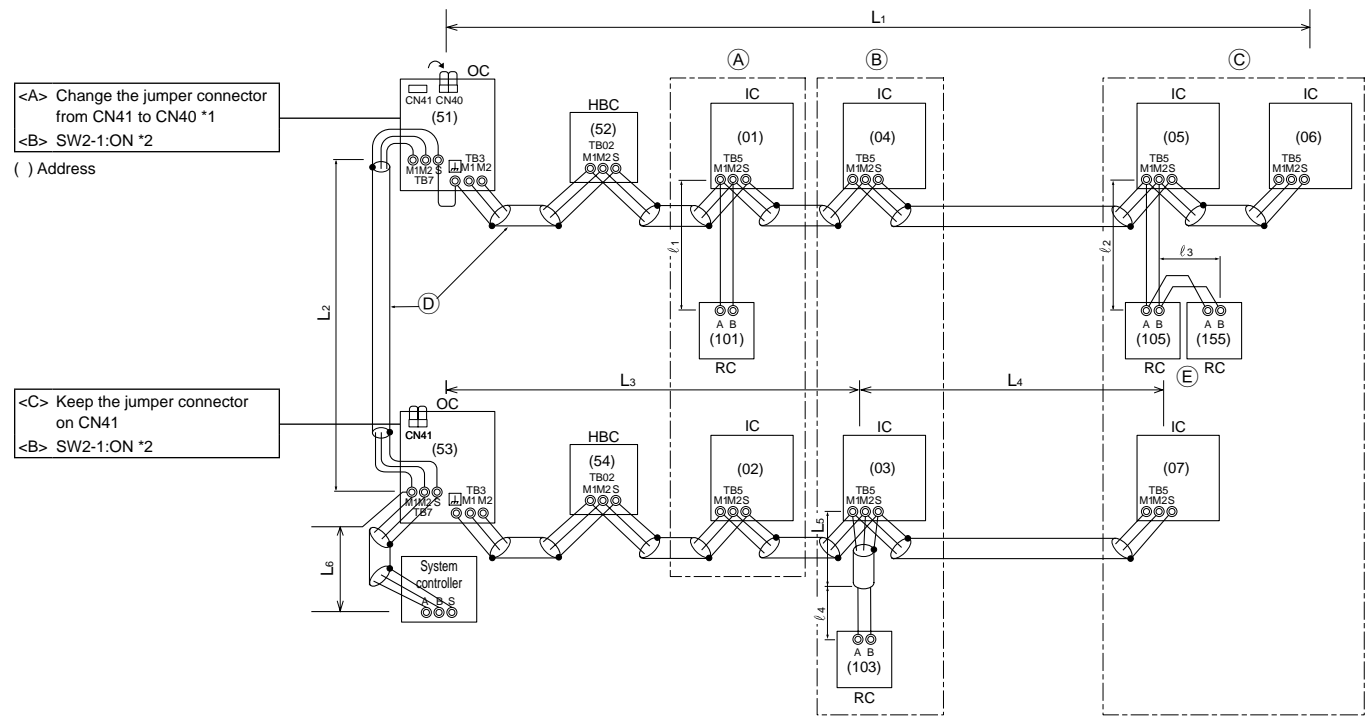

*1 When the power supply unit is not connected to the transmission line for centralized control, disconnect the male power supply connector (CN41) from ONE outdoor unit in the system and connect it to CN40.
 *2 If a system controller is used, set SW2-1 on all of the outdoor units to ON.

[Fig. 11.3.2]

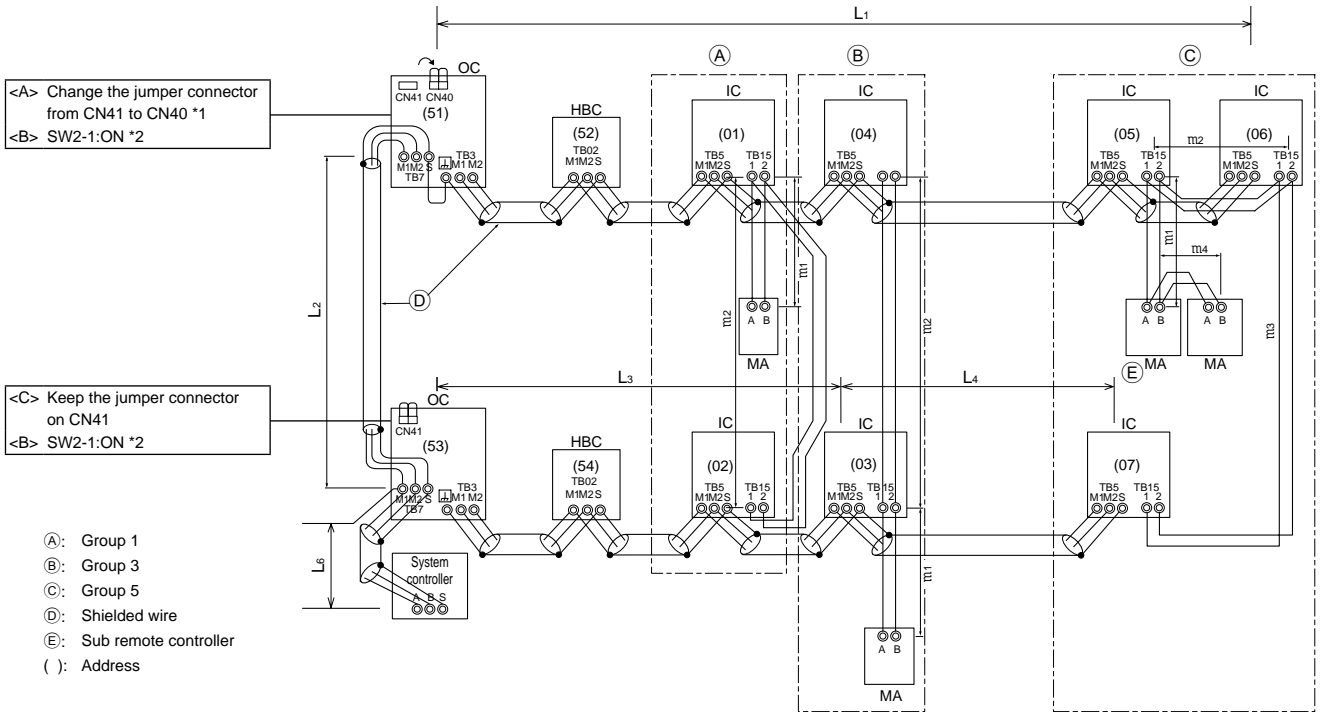

*1 When the power supply unit is not connected to the transmission line for centralized control, disconnect the male power supply connector (CN41) from ONE outdoor unit in the system and connect it to CN40.
*2 If a system controller is used, set SW2-1 on all of the outdoor units to ON.

[Fig. 11.3.3]

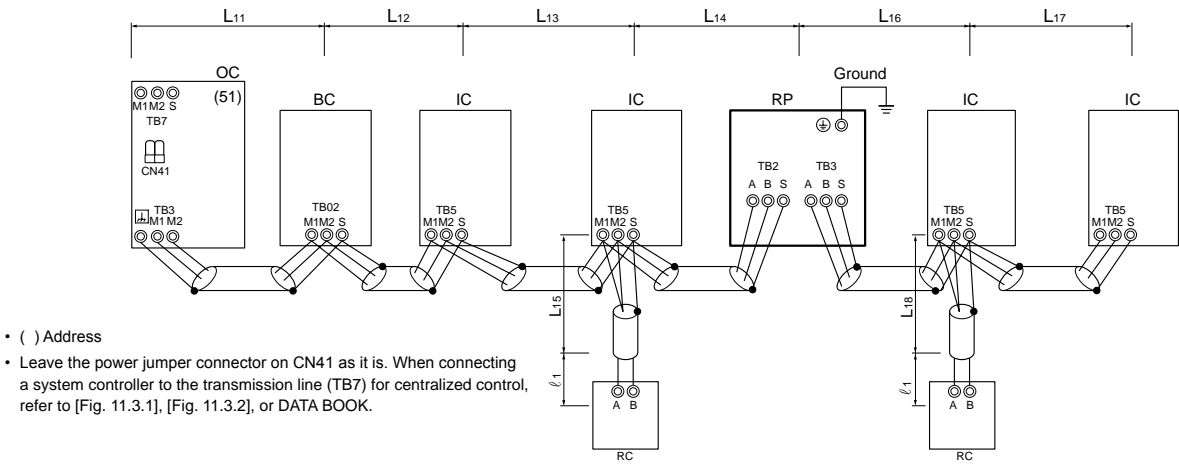

11.4

[Fig. 11.4.1]

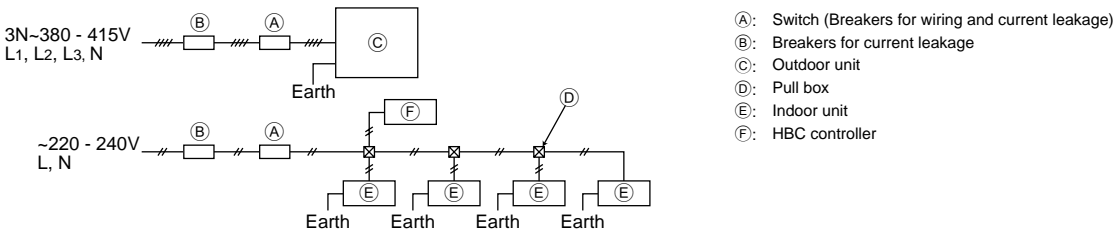

1. Safety precautions	9	10. Additional refrigerant charge	14
1.1. Before installation and electric work	9	10.1. Calculation of additional refrigerant charge	14
1.2. Precautions for devices that use R410A refrigerant	10	10.2. Precautions concerning piping connection and valve operation	15
1.3. Before installation	10	10.3. Airtight test, evacuation, and refrigerant charging	16
1.4. Before installation (relocation) - electrical work	10	10.4. Thermal insulation of refrigerant piping	17
1.5. Before starting the test run	10	11. Wiring (For details, refer to the installation manual of each unit and controller.)	17
2. About the product	11	11.1. Caution	17
3. Outdoor unit model	11	11.2. Control box and connecting position of wiring	17
4. Specifications	11	11.3. Wiring transmission cables	18
5. Confirmation of parts attached	11	11.4. Wiring of main power supply and equipment capacity	19
6. Space required around unit	11	12. Test run	20
7. Lifting method	12	12.1. The following phenomena do not represent faults.	20
8. Installation of unit	12	13. Information on rating plate	20
8.1. Installation	12		
9. Refrigerant piping installation	12		
9.1. Caution	12		
9.2. Refrigerant piping system	13		

1. Safety precautions

1.1. Before installation and electric work





- ▶ Before installing the unit, make sure you read all the "Safety precautions".
- ▶ The "Safety precautions" provide very important points regarding safety. Make sure you follow them.

Symbols used in the text

 **Warning:**
Describes precautions that should be observed to prevent danger of injury or death to the user.

 **Caution:**
Describes precautions that should be observed to prevent damage to the unit.

Symbols used in the illustrations

-  : Indicates an action that must be avoided.
-  : Indicates that important instructions must be followed.
-  : Indicates a part which must be grounded.
-  : Beware of electric shock. (This symbol is displayed on the main unit label.) <Color: yellow>

-  **Warning:**
Carefully read the labels affixed to the main unit.

HIGH VOLTAGE WARNING:

- Control box houses high-voltage parts.
- When opening or closing the front panel of the control box, do not let it come into contact with any of the internal components.
- Before inspecting the inside of the control box, turn off the power, keep the unit off for at least 10 minutes, and confirm that the voltage between FT-P and FT-N on INV Board has dropped to DC20V or less. (It takes about 10 minutes to discharge electricity after the power supply is turned off.)

Warning:

- Do not use refrigerant other than the type indicated in the manuals provided with the unit and on the nameplate.
 - Doing so may cause the unit or pipes to burst, or result in explosion or fire during use, during repair, or at the time of disposal of the unit.
 - It may also be in violation of applicable laws.
 - MITSUBISHI ELECTRIC CORPORATION cannot be held responsible for malfunctions or accidents resulting from the use of the wrong type of refrigerant.
- Ask the dealer or an authorized technician to install the air conditioner.
 - Improper installation by the user may result in water leakage, electric shock, or fire.
- This appliance is not intended for use by persons (including children) with reduced physical, sensory or mental capabilities, or lack of experience and knowledge, unless they have been given supervision or instruction concerning use of the appliance by a person responsible for their safety.
- Install the unit at a place that can withstand its weight.
 - Failure to do so may cause the unit to fall down, resulting in injuries and damage to the unit.
- Use the specified cables for wiring. Make the connections securely so that the outside force of the cable is not applied to the terminals.
 - Inadequate connection and fastening may generate heat and cause a fire.

- Prepare for strong winds and earthquakes and install the unit at the specified place.
 - Improper installation may cause the unit to topple and result in injury and damage to the unit.
- Always use filters and other accessories specified by Mitsubishi Electric.
 - Ask an authorized technician to install the accessories. Improper installation by the user may result in water leakage, electric shock, or fire.
- Never repair the unit. If the air conditioner must be repaired, consult the dealer.
 - If the unit is repaired improperly, water leakage, electric shock, or fire may result.
- If the supply cord is damaged, it must be replaced by the manufacturer, its service agent or similarly qualified persons in order to avoid a hazard.
- Do not touch the heat exchanger fins.
 - Improper handling may result in injury.
- If refrigerant gas leaks during installation work, ventilate the room.
 - If the refrigerant gas comes into contact with a flame, poisonous gases will be released.
- Install the air conditioner according to this Installation Manual.
 - If the unit is installed improperly, water leakage, electric shock, or fire may result.
- Have all electric work done by a licensed electrician according to "Electric Facility Engineering Standard" and "Interior Wire Regulations" and the instructions given in this manual and always use a dedicated power supply.
 - If the power source capacity is inadequate or electric work is performed improperly, electric shock and fire may result.
- Securely install the outdoor unit terminal cover (panel).
 - If the terminal cover (panel) is not installed properly, dust or water may enter the outdoor unit and fire or electric shock may result.
- When installing and moving the air conditioner to another site, do not charge it with a refrigerant different from the refrigerant specified on the unit.
 - If a different refrigerant or air is mixed with the original refrigerant, the refrigerant cycle may malfunction and the unit may be damaged.
- If the air conditioner is installed in a small room, measures must be taken to prevent the refrigerant concentration from exceeding the safety limit if the refrigerant should leak.
 - Consult the dealer regarding the appropriate measures to prevent the safety limit from being exceeded. Should the refrigerant leak and cause the safety limit to be exceeded, hazards due to lack of oxygen in the room could result.
- When moving and reinstalling the air conditioner, consult the dealer or an authorized technician.
 - If the air conditioner is installed improperly, water leakage, electric shock, or fire may result.
- After completing installation work, make sure that refrigerant gas is not leaking.
 - If the refrigerant gas leaks and is exposed to a fan heater, stove, oven, or other heat source, it may generate noxious gases.
- Do not reconstruct or change the settings of the protection devices.
 - If the pressure switch, thermal switch, or other protection device is shorted or operated forcibly, or parts other than those specified by Mitsubishi Electric are used, fire or explosion may result.
- To dispose of this product, consult your dealer.
- The installer and system specialist shall secure safety against leakage according to local regulation or standards.
 - Choose the appropriate wire size and the switch capacities for the main power supply described in this manual if local regulations are not available.
- Pay special attention to the place of installation, such as a basement, etc. where refrigeration gas can accumulate, since refrigerant is heavier than the air.

- For outdoor units that allow fresh air intake to the indoor unit, the installation site must be carefully chosen to ensure only clean air can enter the room.
 - Direct exposure to outdoor air may have harmful effects on people or food.
- Children should be supervised to ensure that they do not play with the appliance.

1.2. Precautions for devices that use R410A refrigerant

⚠ Caution:

- **Do not use existing refrigerant piping.**
 - The old refrigerant and refrigerant oil in the existing piping contains a large amount of chlorine which may cause the refrigerant oil of the new unit to deteriorate.
 - R410A is a high-pressure refrigerant and can cause the existing piping to burst.
- **Use refrigerant piping made of phosphorus deoxidized copper and copper alloy seamless pipes and tubes. In addition, be sure that the inner and outer surfaces of the pipes are clean and free of hazardous sulphur, oxides, dust/dirt, shaving particles, oils, moisture, or any other contaminant.**
 - Contaminants on the inside of the refrigerant piping may cause the refrigerant oil to deteriorate.
- **Store the piping to be used during installation indoors and keep both ends of the piping sealed until just before brazing. (Store elbows and other joints in a plastic bag.)**
 - If dust, dirt, or water enters the refrigerant cycle, deterioration of the oil and compressor failure may result.
- **Apply a small amount of ester oil, ether oil, or alkyl benzene to flares. (for indoor unit)**
 - Infiltration of a large amount of mineral oil may cause the refrigerant oil to deteriorate.
- **Use liquid refrigerant to fill the system.**
 - If gas refrigerant is used to fill the system, the composition of the refrigerant in the cylinder will change and performance may drop.
- **Do not use a refrigerant other than R410A.**
 - If another refrigerant (R22, etc.) is mixed with R410A, the chlorine in the refrigerant may cause the refrigerant oil to deteriorate.
- **Use a vacuum pump with a reverse flow check valve.**
 - The vacuum pump oil may flow back into the refrigerant cycle and cause the refrigerant oil to deteriorate.
- **Do not use the following tools that are used with conventional refrigerants. (Gauge manifold, charge hose, gas leak detector, reverse flow check valve, refrigerant charge base, refrigerant recovery equipment)**
 - If the conventional refrigerant and refrigerant oil are mixed in the R410A, the refrigerant may deteriorate.
 - If water is mixed in the R410A, the refrigerant oil may deteriorate.
 - Since R410A does not contain any chlorine, gas leak detectors for conventional refrigerants will not react to it.
- **Do not use a charging cylinder.**
 - Using a charging cylinder may cause the refrigerant to deteriorate.
- **Be especially careful when managing the tools.**
 - If dust, dirt, or water gets into the refrigerant cycle, the refrigerant may deteriorate.

1.3. Before installation

⚠ Caution:

- **Do not install the unit where combustible gas may leak.**
 - If the gas leaks and accumulates around the unit, an explosion may result.
- **Do not use the air conditioner where food, pets, plants, precision instruments, or artwork are kept.**
 - The quality of the food, etc. may deteriorate.
- **Do not use the air conditioner in special environments.**
 - Oil, steam, sulfuric smoke, etc. can significantly reduce the performance of the air conditioner or damage its parts.
- **When installing the unit in a hospital, communication station, or similar place, provide sufficient protection against noise.**
 - Inverter equipment, private power generator, high-frequency medical equipment, or radio communication equipment may cause the air conditioner to operate erroneously, or fail to operate. On the other hand, the air conditioner may affect such equipment by creating noise that disturbs medical treatment or image broadcasting.
- **Do not install the unit on or over things that are subject to water damage.**
 - When the room humidity exceeds 80% or when the drain pipe is clogged, condensation may drip from the indoor unit. Perform collective drainage work together with the outdoor unit, as required.

1.4. Before installation (relocation) - electrical work

⚠ Caution:

- **Ground the unit.**
 - Do not connect the ground wire to gas or water pipes, lightning rods, or telephone ground lines. Improper grounding may result in electric shock.
- **Never connect in reverse phases.**
 - **Never connect the Power Line L1, L2, and L3 to Terminal N.**
 - If the unit is miss wired, when power is supplied, some electrical parts will be damaged.
- **Install the power cable so that tension is not applied to the cable.**
 - Tension may cause the cable to break and generate heat and cause a fire.
- **Install a leak circuit breaker, as required.**
 - If a leak circuit breaker is not installed, electric shock may result.
- **Use power line cables of sufficient current carrying capacity and rating.**
 - Cables that are too small may leak, generate heat, and cause a fire.
- **Use only a circuit breaker and fuse of the specified capacity.**
 - A fuse or circuit breaker of a larger capacity, or the use of a substitute simple steel or copper wire may result in a general unit failure or fire.
- **Do not wash the air conditioner units.**
 - Washing them may cause an electric shock.
- **Be careful that the installation base is not damaged by long use.**
 - If the damage is left uncorrected, the unit may fall and cause personal injury or property damage.
- **Install the drain piping according to this Installation Manual to ensure proper drainage. Wrap thermal insulation around the pipes to prevent condensation.**
 - Improper drain piping may cause water leakage and damage to furniture and other possessions.
- **Be very careful about transporting the product.**
 - One person should not carry the product. Its weight is in excess of 20kg.
 - Some products use PP bands for packaging. Do not use any PP bands as a means of transportation. It is dangerous.
 - Do not touch the heat exchanger fins. Doing so may cut your fingers.
 - When transporting the outdoor unit, support it at the specified positions on the unit base. Also support the outdoor unit at four points so that it cannot slip sideways.
- **Safely dispose of the packing materials.**
 - Packing materials, such as nails and other metal or wooden parts, may cause stabs or other injuries.
 - Tear apart and throw away plastic packaging bags so that children will not play with them. If children play with a plastic bag which has not been torn apart, they face the risk of suffocation.

1.5. Before starting the test run

⚠ Caution:

- **Turn on the power at least 12 hours before starting operation.**
 - Starting operation immediately after turning on the main power switch can result in irreversible damage to internal parts. Keep the power switch turned on during the operational season. Make sure of the phase order of power supply and voltage between each phase.
- **Do not touch the switches with wet fingers.**
 - Touching a switch with wet fingers can result in an electric shock.
- **Do not touch the refrigerant pipes during and immediately after operation.**
 - During and immediately after operation, the refrigerant pipes may be hot or cold, depending on the condition of the refrigerant flowing through the refrigerant piping, compressor, and other refrigerant cycle parts. Your hands may suffer burns or frostbite if you touch the refrigerant pipes.
- **Do not operate the air conditioner with the panels and guards removed.**
 - Rotating, hot, or high-voltage parts can cause injuries.
- **Do not turn off the power immediately after stopping operation.**
 - Always wait at least 5 minutes before turning off the power. Otherwise, drainage water leakage or mechanical failure of sensitive parts may occur.
- **Do not touch the surface of the compressor during servicing.**
 - If unit is connected to a supply and not running, the crank case heater located at the base of the compressor may still be operating.

2. About the product

- This unit uses R410A-type refrigerant.
- Piping for systems using R410A may be different from that for systems using conventional refrigerant because the design pressure in systems using R410A is higher. Refer to the Data Book for more information.
- Some of the tools and equipment used for installation with systems that use other types of refrigerant cannot be used with the systems using R410A. Refer to the Data Book for more information.

- Do not use the existing piping, as it contains chlorine, which is found in conventional refrigerating machine oil and refrigerant. This chlorine will deteriorate the refrigerant machine oil in the new equipment. The existing piping must not be used as the design pressure in systems using R410A is higher than that in the systems using other types of refrigerant and the existing pipes may burst.

⚠ Caution:

- **Do not vent R410A into the atmosphere.**
- **R410A is a Fluorinated Greenhouse gas, covered by the Kyoto Protocol with a Global Warming Potential (GWP) = 1975.**

3. Outdoor unit model

Outdoor unit model
PURY-WP200YJM-A(-BS)
PURY-WP250YJM-A(-BS)

4. Specifications

Model	PURY-WP200YJM-A	PURY-WP250YJM-A
Noise level (50/60Hz)	60 dB <A>	60 dB <A>
External static pressure	0 Pa *2	
Indoor units	Total capacity	50~150% *1
	Model	20~50
	Quantity	1~20 1~25
Operation temperature	Standard type	Cooling mode: -5°CDB ~ 46°CDB
		Heating mode: -20°CWB ~ 15.5°CWB

* Connectable branch pipe number is max.48.

*1: The total indoor capacity of units run simultaneously is 150% or less.

*2: To enable high static pressure with WP200 and WP250, set the DipSW on the main panel as follows.
SW3-9: ON, SW3-10 60Pa compatible: OFF, 30Pa compatible: ON

5. Confirmation of parts attached

- This unit includes the following parts. Please check.
- For usage methods, refer to item 10.2.

	① Connecting pipe ID ø25.4, ID ø22.2 <Low-pressure side>	② Connecting pipe ID ø25.4, OD ø19.05 <High-pressure side> <Low-pressure side>	③ Connecting pipe ID ø25.4, OD ø15.88 <High-pressure side>	④ Connecting elbow ID ø19.05, OD ø19.05 <High-pressure side> <Low-pressure side>	⑤ Connecting elbow ID ø15.88, ID ø15.88 <High-pressure side>
Model	WP200YJM	1 pc.	1 pc.	1 pc.	1 pc.
	WP250YJM	1 pc.	1 pc.	1 pc.	1 pc.

6. Space required around unit

① In case of single installation

- Secure enough space around the unit as shown in the figure on page 2.

[Fig. 6.0.1] (P.2)

- <A> Top view Side view
<C> When there is little space up to an obstruction
(A) Front (B) Unit height
(C) Back (D) Air outlet guide (Procured at the site)

- (1) If the distance is 300 mm or more between the rear side and the wall
- (2) If the distance is 100 mm or more between the rear side and the wall
- (3) If the wall height (H) of the front, rear or side exceeds the wall height restriction

- When the height of the walls on the front, back or on the sides <H> exceeds the wall height limit as defined here, add the height that exceeds the height limit <h> to the figures that are marked with an asterisk.
- If the unit cannot be kept clear of the wall, please change the direction of the air outlet of the unit to blow against the wall to avoid air short cycle.

<Wall height limit> Front: Up to the unit height
Back: Up to 500 mm from the unit bottom
Side: Up to the unit height

(4) If there are obstacles at the upper part of the unit

② In case of collective installation

[Fig. 6.0.2] (P.2)

- (A) Front (B) Must be open
(C) Wall height (H)

- When multiple units are installed adjacent to each other, secure enough space to allow for air circulation and walkway between groups of units as shown in the figures on page 2.
- At least two sides must be left open.
- As with the single installation, add the height that exceeds the height limit <h> to the figures that are marked with an asterisk.
- If there is a wall at both the front and the rear of the unit. Install up to six units consecutively in the side direction and provide a space of 1000 mm or more as inlet space/passage space for each six units.

7. Lifting method

[Fig. 7.0.1] (P.3)

- Use suspension ropes that will withstand the weight of the unit.
- When moving the unit, use a **4-point suspension**, and avoid giving impacts to the unit (Do not use **2-point suspension**).
- Place protective pads on the unit where it comes in contact with the ropes to protect the unit from being scratched.
- Set the angle of roping at 40° or less.
- Use 2 ropes that are each longer than 8 meters.

- Place protective padding at the corners of the product to protect the product from scratches or dents that might be caused by the rope.

⚠ Caution:

Be very careful when carrying/moving the product.

- When installing the outdoor unit, suspend the unit at the specified location of the unit base. Stabilize as necessary so that it does not move to the side and support it at 4 points. If the unit is installed or suspended with 3-point support, the unit may become unstable and fall.

8. Installation of unit

8.1. Installation

[Fig. 8.1.1] (P.3)

- | | |
|--|-------------------------|
| <A> Without detachable leg | With detachable leg |
| Ⓐ M10 anchor bolt procured at the site. | Ⓑ Corner is not seated. |
| Ⓒ Fixing bracket for the hole-in anchor bolt (3 locations to fix with screws). | Ⓓ Detachable leg |

- Fix unit tightly with bolts so that unit will not fall down due to earthquakes or strong winds.
- Use concrete or an angle bracket for the foundation of unit.
- Vibration may be transmitted to the installation section and noise and vibration may be generated from the floor and walls, depending on the installation conditions. Therefore, provide ample vibrationproofing (cushion pads, cushion frame, etc.).
- Be sure that the corners are firmly seated. If the corners are not firmly seated, the installation feet may be bent.
- When using cushion pads, be sure that the full width of the unit is covered.
- The projecting length of the anchor bolt should be less than 30 mm.
- Hole-in anchor bolts are not compatible with this product. However, if fixing brackets are mounted on the 4 locations of the unit attachment part, hole-in anchor bolts can be used.

[Fig. 8.1.2]

- Ⓐ Screws

- The detachable leg can be removed at the site.
- Detaching the detachable leg
Loosen the three screws to detach the detachable leg (Two each in the front and back).
If the base leg finish is damaged when detaching, be sure to repair at the site.

⚠ Warning:

- **Be sure to install unit in a place strong enough to withstand its weight. Any lack of strength may cause unit to fall down, resulting in a personal injury.**
- **Have installation work in order to protect against strong winds and earthquakes. Any installation deficiency may cause unit to fall down, resulting in a personal injury.**

When building the foundation, give full attention to the floor strength, drain water disposal <during operation, drain water flows out of the unit>, and piping and wiring routes.

Precautions when routing the pipes and wires below the unit (Without detachable leg)

When routing the pipes and wires below the unit, be sure that the foundation and base work do not block the base through-holes. Also make sure the foundation is at least 100 mm high so that the piping can pass under the unit.

9. Refrigerant piping installation

The pipe is connected via a terminal-branch type connection in which refrigerant piping from the outdoor unit is branched at the terminal and is connected to each of the indoor units.

The method of pipe connection is as follows: brazed connection, low-pressure pipes and high-pressure pipes for outdoor unit.

⚠ Warning:

- **Do not use refrigerant other than the type indicated in the manuals provided with the unit and on the nameplate.**
 - Doing so may cause the unit or pipes to burst, or result in explosion or fire during use, during repair, or at the time of disposal of the unit.
 - It may also be in violation of applicable laws.
 - MITSUBISHI ELECTRIC CORPORATION cannot be held responsible for malfunctions or accidents resulting from the use of the wrong type of refrigerant.

Always use extreme care to prevent the refrigerant gas from leaking while using fire or flame. If the refrigerant gas comes in to contact with a flame from any source, such as a gas stove, it breaks down and generates a poisonous gas which can cause gas poisoning. Never weld in an unventilated room. Always conduct an inspection for gas leakage after installation of the refrigerant piping has been completed.

⚠ Caution:

- **Do not vent R410A into the atmosphere.**
- **R410A is a Fluorinated Greenhouse gas, covered by the Kyoto Protocol with a Global Warming Potential (GWP) = 1975.**

9.1. Caution

This unit uses refrigerant R410A. Follow the local regulations on materials and pipe thickness when selecting pipes. (Refer to the table below.)

- ① Use the following materials for refrigeration piping.
 - Material: Use copper alloy seamless pipes made of phosphorus deoxidized copper. Ensure the inner and outer surfaces of the pipes are clean and free from hazardous sulfur, oxide, dusts, shaving particles, oils, and moisture (contamination).
 - Size: Refer to item 9.2. for detailed information on refrigerant piping system.
- ② Commercially available piping often contains dust and other materials. Always blow it clean with a dry inert gas.
- ③ Use care to prevent dust, water or other contaminants from entering the piping during installation.
- ④ Reduce the number of bending portions as much as possible, and make bending radii as big as possible.

Copper pipe size and radial thickness for R410A CITY MULTI.

Size (mm)	Size (inch)	Radial thickness (mm)	Pipe type
ø6.35	ø1/4"	0.8	Type-O
ø9.52	ø3/8"	0.8	Type-O
ø12.7	ø1/2"	0.8	Type-O
ø15.88	ø5/8"	1.0	Type-O
*ø19.05	ø3/4"	1.2	Type-O
*ø19.05	ø3/4"	1.0	Type-1/2H or H
ø22.2	ø7/8"	1.0	Type-1/2H or H
ø25.4	ø1"	1.0	Type-1/2H or H
ø28.58	ø1-1/8"	1.0	Type-1/2H or H
ø31.75	ø1-1/4"	1.1	Type-1/2H or H
ø34.93	ø1-3/8"	1.2	Type-1/2H or H
ø41.28	ø1-5/8"	1.4	Type-1/2H or H

* Both pipe types can be used for pipe size ø19.05 (3/4 inch) for R410A air conditioner.

- ⑥ Use a fitting if a specified refrigerant pipe has a different diameter from that of a branching pipe.
- ⑦ Always observe the restrictions on the refrigerant piping (such as rated length, height difference, and piping diameter) to prevent equipment failure or a decline in heating/cooling performance.
- ⑧ Either a lack or an excess of refrigerant causes the unit to make an emergency stop. Charge the system with an appropriate amount of refrigerant. When servicing, always check the notes concerning pipe length and amount of additional refrigerant at both locations, the refrigerant volume calculation table on the back of the service panel and the additional refrigerant section on the labels for the combined number of indoor units (Refer to item 9.2. for detailed information on refrigerant piping system).
- ⑨ **Be sure to charge the system using liquid refrigerant.**
- ⑩ **Never use refrigerant to perform an air purge.** Always evacuate using a vacuum pump.
- ⑪ Always insulate the piping properly. Insufficient insulation will result in a decline in heating/cooling performance, water drops from condensation and other such problems (Refer to item 10.4 for thermal insulation of refrigerant piping).
- ⑫ When connecting the refrigerant piping, make sure the valve of the outdoor unit is completely closed (the factory setting) and do not operate it until the refrigerant piping for the outdoor units and HBC controller has been connected, a refrigerant leakage test has been performed and the evacuation process has been completed.
- ⑬ **Braze only with non-oxide brazing material for piping. Failure to do so may damage the compressor. Be sure to perform the non-oxidation brazing with a nitrogen purge.**
Do not use any commercially available anti-oxidizing agent since it may cause pipe corrosion and degrading of the refrigerant oil.
Please contact Mitsubishi Electric for more details.
 (Refer to item 10.2. for details of the piping connection and valve operation)
- ⑭ **Never perform outdoor unit piping connection work when it is raining.**

⚠ Warning:

When installing and moving the unit, do not charge the system with any other refrigerant other than the refrigerant specified on the unit.

- Mixing of a different refrigerant, air, etc. may cause the refrigerant cycle to malfunction and may result in severe damage.

⚠ Caution:

- **Use a vacuum pump with a reverse flow check valve.**
 - If the vacuum pump does not have a reverse flow check valve, the vacuum pump oil may flow back into the refrigerant cycle and cause deterioration of the refrigerant oil.
- **Do not use the tools shown below used with conventional refrigerant. (Gauge manifold, charge hose, gas leak detector, check valve, refrigerant charge base, vacuum gauge, refrigerant recovery equipment)**
 - Mixing of conventional refrigerant and refrigerant oil may cause the refrigerant oil to deteriorate.
 - Mixing of water will cause the refrigerant oil to deteriorate.
 - R410A refrigerant does not contain any chlorine. Therefore, gas leak detectors for conventional refrigerants will not react to it.
- **Manage the tools used for R410A more carefully than normal.**
 - If dust, dirt, or water gets in the refrigerant cycle, the refrigerant oil will deteriorate.
- **Never use existing refrigerant piping.**
 - The large amount of chlorine in conventional refrigerant and refrigerant oil in the existing piping will cause the new refrigerant to deteriorate.
- **Store the piping to be used during installation indoors and keep both ends of the piping sealed until just before brazing.**
 - If dust, dirt, or water gets into the refrigerant cycle, the oil will deteriorate and the compressor may fail.
- **Do not use a charging cylinder.**
 - Using a charging cylinder may cause the refrigerant to deteriorate.
- **Do not use special detergents for washing piping.**

9.2. Refrigerant piping system

Connection example

[Fig. 9.2.1] (P.3)

- | | |
|------------------------|----------------------------------|
| Ⓐ Outdoor model | Ⓑ High-pressure side |
| Ⓒ Low-pressure side | Ⓓ Total capacity of indoor units |
| Ⓔ Water out | Ⓔ Water return |
| Ⓖ Model number | |
| Ⓐ Outdoor unit | Ⓑ HBC controller |
| Ⓒ Indoor unit (20- 50) | |

⚠ Caution:

- **Do not install solenoid valves to prevent oil backflow and compressor start-up failure.**
- **Do not install a sight glass because it may show improper refrigerant flow.**

If a sight glass is installed, inexperienced technicians that use the glass may overcharge the refrigerant.

10. Additional refrigerant charge

At the time of shipping, the outdoor unit is charged with refrigerant. This charge does not include the amount needed for extended piping and additional charging of each refrigerant line will be required on site. In order that future servicing may be properly provided, always keep a record of the size and length of each refrigerant line and the amount of additional charge by writing it in the space provided on the outdoor unit.

10.1. Calculation of additional refrigerant charge

- Calculate the amount of additional charge based on the length of the piping extension and the size of the refrigerant line.
- Use the table below as a guide for calculating the amount of additional charging and then charge the system accordingly.
- If the calculation results in a fraction of less than 0.1 kg, round up to the next 0.1 kg. For example, if the result of the calculation was 6.72 kg, round the result up to 6.8 kg.

<Additional charge>

Additional refrigerant charge (kg)	=	High-pressure pipe size Total length of ø28.58 x0.36 (m)x0.36 (kg/m)	+	High-pressure pipe size Total length of ø22.2 x0.23 (m)x0.23 (kg/m)	+	High-pressure pipe size Total length of ø19.05 x0.16 (m)x0.16 (kg/m)	+	High-pressure pipe size Total length of ø15.88 x0.11 (m)x0.11 (kg/m)	+	Liquid Piping Size Total length of ø15.88 x0.2 (m)x0.2 (kg/m)	
	+	Liquid Piping Size Total length of ø12.7 x0.12 (m)x0.12 (kg/m)	+	Liquid Piping Size Total length of ø9.52 x0.06 (m)x0.06 (kg/m)	+	Liquid Piping Size Total length of ø6.35 x0.024 (m)x0.024 (kg/m)					
	+	Total Outdoor Unit Model Name WP200, 250									HBC controller 3.0 kg

<Example>

Indoor	1: 50	A: ø19.05	42 m	a: ø20	10 m	} At the conditions below:
	2: 50	B: ø20	10 m	b: ø20	5 m	
	3: 50			c: ø20	5 m	
	4: 40			d: ø20	10 m	
Outdoor	WP250					

The total length of each liquid line is as follows:

ø19.05: A = 42 m

Therefore,

<Calculation example>

Additional refrigerant charge

= 42 x 0.16

= 6.72 kg

* All pipe work except A is water pipe work.

⚠ Caution:

Make sure to seal-off the openings for the pipe and wire retrieval.

- **Small animals, rainwater, or snow entering through the openings may cause damage to the device.**

[Fig. 10.3.1] (P.5)

- (A) Nitrogen gas (B) To indoor unit (C) System analyzer
- (D) Low knob (E) Hi knob (F) Valve
- (G) Low-pressure pipe (H) High-pressure pipe (I) Outdoor unit
- (J) Service port

Observe the following restrictions when conducting an air tightness test to prevent negative effects on the refrigerating machine oil. Also, with nonazeotropic refrigerant (R410A), gas leakage causes the composition to change and affects performance. Therefore, perform the airtightness test cautiously.

10.3. Airtight test, evacuation, and refrigerant charging

① **Airtight test**

Perform with the valve of the outdoor unit closed, and pressurize the connection piping and the indoor unit from the service port provided on the valve of the outdoor unit. (Always pressurize from both the high-pressure pipe and the low-pressure pipe service ports.)

Airtight test procedure	Restriction
<p>(1) After pressurizing to the design pressure (4.15 MPa) using nitrogen gas, allow it to stand for about one day. If the pressure does not drop, airtightness is good. However, if the pressure drops, since the leaking point is unknown, the following bubble test may also be performed.</p> <p>(2) After the pressurization described above, spray the flare connection parts, brazed parts, and other parts that may leak with a bubbling agent (Gupoflex, etc.) and visually check for bubbles.</p> <p>(3) After the airtight test, wipe off the bubbling agent.</p>	<ul style="list-style-type: none"> • If a flammable gas or air (oxygen) is used as the pressurization gas, it may catch fire or explode.

⚠ Caution:

Only use refrigerant R410A.

- The use of other refrigerants such as R22 or R407C, which contains chlorine, will deteriorate the refrigerating machine oil or cause the compressor to malfunction.

② **Evacuation**

Evacuate with the valve of the outdoor unit closed and evacuate both the connection piping and the indoor unit from the service port provided on the valve of the outdoor unit using a vacuum pump. (Always evacuate from the service port of both the high-pressure pipe and the low-pressure pipe.) After the vacuum reaches 650 Pa [abs], continue evacuation for at least one hour or more. Then, stop the vacuum pump and leave it for 1 hour. Ensure the degree of vacuum has not increased. **(If the degree of vacuum increase is larger than 130 Pa, water might have entered. Apply pressure to dry nitrogen gas up to 0.05 MPa and vacuum again.)** Finally, seal in with the liquid refrigerant through the high-pressure pipe, and adjust the low-pressure piping to obtain an appropriate amount of the refrigerant during operation.
* Never perform air purging using refrigerant.

[Fig. 10.3.2] (P.6)

- (A) System analyzer (B) Low knob (C) Hi knob
- (D) Valve (E) Low-pressure pipe (F) High-pressure pipe
- (G) Service port (H) Three-way joint (I) Valve
- (J) Valve (K) R410A cylinder (L) Scale
- (M) Vacuum pump (N) To indoor unit (O) Outdoor unit

Note:

- **Always add an appropriate amount of refrigerant. Also always charge the system with liquid refrigerant.**
- **Use a gauge manifold, charging hose, and other parts for the refrigerant indicated on the unit.**
- **Use a gravimeter. (One that can measure down to 0.1 kg.)**
- **Use a vacuum pump with a reverse flow check valve. (Recommended vacuum gauge: ROBINAIR 14830A Thermistor Vacuum Gauge) Also use a vacuum gauge that reaches 65 Pa [abs] or below after operating for five minutes.**

③ **Refrigerant Charging**

- **Do not use refrigerant other than the type indicated in the manuals provided with the unit and on the nameplate.**
 - Doing so may cause the unit or pipes to burst, or result in explosion or fire during use, during repair, or at the time of disposal of the unit.
 - It may also be in violation of applicable laws.
 - MITSUBISHI ELECTRIC CORPORATION cannot be held responsible for malfunctions or accidents resulting from the use of the wrong type of refrigerant.

Since the refrigerant used with the unit is nonazeotropic, it must be charged in the liquid state. Consequently, when charging the unit with refrigerant from a cylinder, if the cylinder does not have a syphon pipe, charge the liquid refrigerant by turning the cylinder upside-down as shown in Fig.10.3.3. If the cylinder has a syphon pipe like that shown in the picture on the right, the liquid refrigerant can be charged with the cylinder standing upright. Therefore, give careful attention to the cylinder specifications. If the unit should be charged with gas refrigerant, replace all the refrigerant with new refrigerant. Do not use the refrigerant remaining in the cylinder.

[Fig. 10.3.3] (P.6)

- (A) Syphon pipe (B) In case of the R410A cylinder having no syphon pipe.

10.4. Thermal insulation of refrigerant piping

Be sure to add insulation work to refrigerant piping by covering high-pressure pipe and low-pressure pipe separately with enough thickness heat-resistant polyethylene, so that no gap is observed in the joint between HBC controller and insulating material, and insulating materials themselves. When insulation work is insufficient, there is a possibility of condensation drip, etc. Pay special attention to insulation work in the ceiling plenum.

[Fig. 10.4.1] (P.6)

- (A) Steel wire
- (B) Piping
- (C) Asphaltic oily mastic or asphalt
- (D) Heat insulation material A
- (E) Outer covering B

Heat insulation material A	Glass fiber + Steel wire	
	Adhesive + Heat - resistant polyethylene foam + Adhesive tape	
Outer covering B	Indoor	Vinyl tape
	Floor exposed	Water-proof hemp cloth + Bronze asphalt
	Outdoor	Water-proof hemp cloth + Zinc plate + Oily paint

Note:

- When using polyethylene as a covering material, asphalt roofing shall not be required.
- No heat insulation must be provided to electric wires.

[Fig. 10.4.2] (P.6)

- (A) High-pressure pipe
- (B) Low-pressure pipe
- (C) Electric wire
- (D) Finishing tape
- (E) Insulator

[Fig. 10.4.3] (P.6)

Penetrations

[Fig. 10.4.4] (P.6)

- <A> Inner wall (concealed)
- Outer wall
- <C> Outer wall (exposed)
- <D> Floor (waterproofing)
- <E> Roof pipe shaft
- <F> Penetrating portion on fire limit and boundary wall
- (A) Sleeve
- (B) Heat insulating material
- (C) Lagging
- (D) Caulking material
- (E) Band
- (F) Waterproofing layer
- (G) Sleeve with edge
- (H) Lagging material
- (I) Mortar or other incombustible caulking
- (J) Incombustible heat insulation material

When filling a gap with mortar, cover the penetration part with steel plate so that the insulation material will not be caved in. For this part, use incombustible materials for both insulation and covering. (Vinyl covering should not be used.)

- Insulation materials for the pipes to be added on site must meet the following specifications:

Outdoor unit	High-pressure pipe	10 mm or more
-HBC controller	Low-pressure pipe	20 mm or more

- * Installation of pipes in a high-temperature high-humidity environment, such as the top floor of a building, may require the use of insulation materials thicker than the ones specified in the chart above.
- * When certain specifications presented by the client must be met, ensure that they also meet the specifications on the chart above.

11. Wiring (For details, refer to the installation manual of each unit and controller.)

11.1. Caution

- ① Follow ordinance of your governmental organization for technical standard related to electrical equipment, wiring regulations and guidance of each electric power company.
- ② Wiring for control (hereinafter referred to as transmission line) shall be (5 cm or more) apart from power source wiring so that it is not influenced by electric noise from power source wiring (Do not insert transmission line and power source wire in the same conduit).
- ③ Be sure to provide designated grounding work to the outdoor unit.
- ④ Give some allowance to wiring for the electrical control box on the indoor and outdoor units, because these boxes are sometimes removed at the time of service work.
- ⑤ Never connect the main power source to the terminal block of the transmission line. If connected, electrical parts will burn out.
- ⑥ Use 2-core shield cable for the transmission line. If transmission lines of different systems are wired with the same multiple-core cable, the resultant poor transmitting and receiving will cause erroneous operations.
- ⑦ Only the transmission line specified should be connected to the terminal block for outdoor unit transmission. Erroneous connection does not allow the system to operate.
- ⑧ In the case of connecting with an upper class controller or to conduct group operation in different refrigerant systems, the control line for transmission is required between the outdoor units in different refrigerant systems. Connect this control line between the terminal blocks for centralized control (2-wire line with no polarity).
- ⑨ Grouping is set by operating the remote controller.

11.2. Control box and connecting position of wiring

① Outdoor unit

1. Remove the front panel of the control box by removing the 4 screws and pushing it up a little before pulling it out.
2. Connect the indoor - outdoor transmission line to the terminal block (TB3) for the indoor - outdoor transmission line. If multiple outdoor units are connected in the same refrigerant system, daisy-chain TB3 (M1, M2, ↗ Terminal) on the outdoor units. Connect the indoor - outdoor transmission line for the outdoor units to TB3 (M1, M2, ↗ Terminal) of only one of the outdoor units.

3. Connect the transmission lines for centralized control (between the centralized control system and the outdoor unit of different refrigerant systems) to the terminal block for centralized control (TB7). If the multiple outdoor units are connected to the same refrigerant system, daisy-chain TB7 (M1, M2, S Terminal) on the outdoor units in the same refrigerant system. (*1)
 - *1: If TB7 on the outdoor unit in the same refrigerant system is not daisy-chained, connect the transmission line for centralized control to TB7 on the OC (*2). If the OC is out of order, or if the centralized control is being conducted during the power supply shut-off, daisy-chain TB7 on the OC and OS (In the case that the outdoor unit whose power supply connector CN41 on the control board has been replaced with CN40 is out of order or the power is shut-off, centralized control will not be conducted even when TB7 is daisy-chained).
 - *2: OC and OS of the outdoor units in the same refrigerant system are automatically identified. They are identified as OC and OS in descending order of capacity (If the capacity is the same, they will be in ascending order of their address number).
4. In the case of indoor-outdoor transmission line, connect the shield ground to the grounding terminal (↗). In the case of transmission lines for centralized control, connect it to the shield terminal (S) on the terminal block for centralized control (TB7). Furthermore, in the case of the outdoor units whose power supply connector CN41 is replaced with CN40, short circuit the shield terminal (S) and the grounding terminal (↗) in addition to the above.
5. Fix the connected wires securely in place with the cable strap at the bottom of the terminal block. External force applied to the terminal block may damage it resulting in a short circuit, ground fault, or a fire.

[Fig. 11.2.1] (P.7)

- (A) Power source
- (B) Transmission line
- (C) Earth screw

[Fig. 11.2.2] (P.7)

- (A) Cable strap
- (B) Power source cable
- (C) Transmission cable
- (D) Pillar

② Conduit tube installation

- Open by hammering the knockout holes for the conduit tube located on the base and the bottom part of the front panel.
- When installing the conduit tube directly through the knockout holes, remove the burr and protect the tube with masking tape.
- Use the conduit tube to narrow down the opening if there is a possibility of small animals entering the unit.
- When taking the conduit tube out from the bottom part of the unit, caulk around the tube opening to prevent water penetration.

11.3. Wiring transmission cables

① Types of control cables

1. Wiring transmission cables

- Types of transmission cables: Shielding wire CVVS, CPEVS or MVVS
- Cable diameter: More than 1.25 mm²
- Maximum wiring length: Within 200 m
- Maximum length of transmission lines for centralized control and indoor/outdoor transmission lines (Maximum length via outdoor units): 500 m MAX
The maximum length of the wiring between power supply unit for transmission lines (on the transmission lines for centralized control) and each outdoor unit and system controller is 200 m.

2. Remote control cables

• ME Remote Controller

Kind of remote control cable	Sheathed 2-core cable (unshielded) CVV
Cable diameter	0.3 to 1.25 mm ² (0.75 to 1.25 mm ²)*
Remarks	When 10 m is exceeded, use cable with the same specifications as 1. Wiring transmission cables.

• MA Remote Controller

Kind of remote control cable	Sheathed 2-core cable (unshielded) CVV
Cable diameter	0.3 to 1.25 mm ² (0.75 to 1.25 mm ²)*
Remarks	Within 200 m

* Connected with simple remote controller.

② Wiring examples

- Controller name, symbol and allowable number of controllers.

Name	Code	Possible unit connections
Outdoor unit	OC	–
HBC controller	HBC	One controller for one OC
Indoor unit	IC	1 to 50 units per 1 OC (*1)
Remote controller	RC	2 units maximum per group
Other	RP	0 to 2 units per 1 OC (*1)

*1 A transmission booster (RP) may be required depending on the number of connected indoor unit controllers.

Example of a group operation system with multiple outdoor units (Shielding wires and address setting are necessary.)

<Examples of transmission cable wiring>

[Fig. 11.3.1] ME Remote Controller (P.7)

*1: When the power supply unit is not connected to the transmission line for centralized control, disconnect the male power supply connector (CN41) from ONE outdoor unit in the system and connect it to CN40.

*2: If a system controller is used, set SW2-1 on all of the outdoor units to ON.

[Fig. 11.3.2] MA Remote Controller (P.8)

<A> Change the jumper connector from CN41 to CN40

 SW2-1:ON

<C> Keep the jumper connector on CN41

(A) Group 1

(B) Group 3

(C) Group 5

(D) Shielded wire

(E) Sub remote controller

() Address

[Fig. 11.3.3] Combination of outdoor units and transmission booster unit (P.8)

• () Address

- Leave the power jumper connector on CN41 as it is. When connecting a system controller to the transmission line (TB7) for centralized control, refer to [Fig. 11.3.1], [Fig. 11.3.2], or DATA BOOK.

<Wiring Method and Address Settings>

- Always use shielded wire when making connections between the outdoor unit (OC) and the indoor unit (IC), as well for all OC-OC and IC-IC wiring intervals.
- Use feed wiring to connect terminals M1 and M2 and the earth terminal \rightarrow on the transmission line terminal block (TB3) of each outdoor unit (OC) to terminals M1, M2 and terminal S on the transmission line block of the indoor unit (IC).
- Connect terminals 1 (M1) and 2 (M2) on the transmission line terminal block of the indoor unit (IC) that has the most recent address within the same group to the terminal block on the remote controller (RC).
- Connect together terminals M1, M2 and terminal S on the terminal block for central control (TB7) for the outdoor unit in a different refrigerant system (OC).
- When the power supply unit is not installed on the central control transmission line, change the jumper connector on the control board from CN41 to CN40 on only one outdoor unit in the system.
- Connect the terminal S on the terminal block for central control (TB7) for the outdoor unit (OC) for the unit into which the jumper connector was inserted into CN40 in the step above to the earth terminal \rightarrow in the electrical component box.
- Set the address setting switch as follows.

* To set the outdoor unit address to 100, the outdoor address setting switch must be set to 50.

Unit	Range	Setting Method
Indoor unit (Main)	01 to 50	Use the most recent address within the same group of indoor units. With an R2 system, set the indoor unit address in the following order: ① Indoor units connected to the HBC controller
Indoor unit (Sub)	01 to 50	Use an address, other than that of the IC (Main) from among the units within the same group of indoor units. This must be in sequence with the IC (Main)
Outdoor Unit (OC)	51 to 100	Set the addresses of the outdoor units in the same refrigerant system in the order of sequential number.
HBC controller	51 to 100	Outdoor unit address plus 1. When the set indoor unit address duplicates the address of another indoor unit, set the new address to a vacant address within the setting range.
ME R/C (Main)	101 to 150	Set at an IC (Main) address within the same group plus 100
ME R/C (Sub)	151 to 200	Set at an IC (Main) address within the same group plus 150
MA R/C	-	Unnecessary address setting (Necessary main/sub setting)

- h. The group setting operations among the multiple indoor units is done by the remote controller (RC) after the electrical power has been turned on.
i. When the centralized remote controller is connected to the system, set centralized control switches (SW2-1) on control boards in all outdoor units (OC) to "ON".

<Permissible Lengths>

① **ME Remote controller [Fig. 11.3.1] (P.7)**

- Max length via outdoor units: L₁+L₂+L₃+L₄ and L₁+L₂+L₃+L₅ and L₁+L₂+L₆ ≤ 500 m (1.25 mm² or more)
- Max transmission cable length: L₁ and L₃+L₄ and L₃+L₅ and L₆ and L₂+L₆ ≤ 200 m (1.25 mm² or more)
- Remote controller cable length: ℓ₁, ℓ₂, ℓ₃, ℓ₄ ≤ 10 m (0.3 to 1.25 mm²)
If the length exceeds 10 m, use a 1.25 mm² shielded wire. The length of this section (L_a) should be included in the calculation of the maximum length and overall length.

② **MA Remote controller [Fig. 11.3.2] (P.8)**

- Max length via outdoor unit (M-NET cable): L₁+L₂+L₃+L₄ and L₁+L₂+L₆ ≤ 500 m (1.25 mm² or more)
- Max transmission cable length (M-NET cable): L₁ and L₃+L₄ and L₆ and L₂+L₆ ≤ 200 m (1.25 mm² or more)
- Remote controller cable length: m₁+m₂ and m₁+m₂+m₃+m₄ ≤ 200 m (0.3 to 1.25 mm²)

③ **Transmission booster [Fig. 11.3.3] (P.8)**

- Max transmission cable length (M-NET cable): ① L₁₁ + L₁₂ + L₁₃ + L₁₄ + L₁₆ + L₁₇ ≤ 200 m (1.25 mm²)
② L₁₁ + L₁₂ + L₁₃ + L₁₄ + L₁₆ + L₁₈ ≤ 200 m (1.25 mm²)
③ L₁₁ + L₁₂ + L₁₃ + L₁₅ ≤ 200 m (1.25 mm²)
④ L₁₇ + L₁₆ + L₁₄ + L₁₅, L₁₅ + L₁₄ + L₁₆ + L₁₈ ≤ 200 m (1.25 mm²)
- Remote controller cable length: ℓ₁, ℓ₂ ≤ 10 m (0.3 to 1.25 mm²)
If the length exceeds 10 m, use 1.25 mm² shielded cable and calculate the length of that portion (L₁₅ and L₁₈) as within the total extended length and the longest remote length.

11.4. Wiring of main power supply and equipment capacity

Schematic Drawing of Wiring (Example)

[Fig. 11.4.1] (P.8)

- Ⓐ Switch (Breakers for wiring and current leakage) Ⓑ Breakers for current leakage Ⓒ Outdoor unit
Ⓓ Pull box Ⓔ Indoor unit Ⓕ HBC controller

Thickness of wire for main power supply, capacities of the switch and system impedance

	Model	Minimum wire thickness (mm ²)			Breaker for current leakage	Local switch (A)		Breaker for wiring (NFB) (A)	Max. Permissible System Impedance
		Main cable	Branch	Ground		Capacity	Fuse		
Outdoor unit	WP200YJM	4.0	-	4.0	30A 100mA 0.1sec. or less	25	25	30	*1
	WP250YJM	4.0	-	4.0	30A 100mA 0.1sec. or less	32	32	30	*1

*1: Meets technical requirements of IEC61000-3-3

1. Use dedicated power supplies for the outdoor unit and indoor unit.
2. Bear in mind ambient conditions (ambient temperature, direct sunlight, rain water, etc.) when proceeding with the wiring and connections.
3. The wire size is the minimum value for metal conduit wiring. If the voltage drops, use a wire that is one rank thicker in diameter.
Make sure the power-supply voltage does not drop more than 10%.
4. Specific wiring requirements should adhere to the wiring regulations of the region.
5. Power supply cords of parts of appliances for outdoor use shall not be lighter than polychloroprene sheathed flexible cord (design 245 IEC57).
6. A switch with at least 3 mm contact separation in each pole shall be provided by the Air Conditioner installer.

Warning:

- Be sure to use specified wires for connections and ensure no external force is imparted to terminal connections. If connections are not fixed firmly, heating or fire may result.
- Be sure to use the appropriate type of overcurrent protection switch. Note that generated overcurrent may include some amount of direct current.

Caution:

- Some installation sites may require attachment of an earth leakage breaker for the inverter. If no earth leakage breaker is installed, there is a danger of electric shock.
- Do not use anything other than a breaker and fuse with the correct capacity. Using a fuse or wire of too large capacity may cause malfunction or fire.

Note:

- This device is intended for the connection to a power supply system with a maximum permissible system impedance shown in the above table at the interface point (power service box) of the user's supply.
- The user must ensure that this device is connected only to a power supply system which fulfils the requirement above.
If necessary, the user can ask the public power supply company for the system impedance at the interface point.
- This equipment complies with IEC 61000-3-12 provided that the short-circuit power S_{sc} is greater than or equal to S_{sc}(*2) at the interface point between the user's supply and the public system. It is the responsibility of the installer or user of the equipment to ensure, by consultation with the distribution network operator if necessary, that the equipment is connected only to a supply with a short-circuit power S_{sc} greater than or equal to S_{sc}(*2).

S_{sc}(*2)

Model	S _{sc} (MVA)
PURY-WP200YJM	1.24
PURY-WP250YJM	1.28

12. Test run

12.1. The following phenomena do not represent faults.

Phenomenon	Display of remote controller	Cause
Indoor unit does not perform cooling (heating) operation.	"Cooling (heating)" flashes	When another indoor unit is performing the heating (cooling) operation, the cooling (heating) operation is not performed.
The auto vane rotates and begins to blow air horizontally.	Normal display	If air has been blowing downward for 1 hour during cooling, the unit may automatically change to horizontal blowing with the control operation of the auto vane. During defrosting or immediately after heating start-up/shut-down, the auto vane automatically rotates to blow air horizontally for a short period of time.
Fan setting changes during heating.	Normal display	Ultra-low speed operation is commenced at thermostat OFF. Light air automatically changes over to set value by time or piping temperature at thermostat ON.
Fan stops during heating operation.	Defrost display	The fan is set to stop during defrosting.
Fan does not stop while operation has been stopped.	No lighting	The fan is set to run for 1 minute after stopping to exhaust residual heat (only in heating).
No setting of fan while start SW has been turned on.	Heat ready	Ultra low-speed operation for 5 minutes after SW ON or until piping temperature becomes 35°C, low speed operation for 2 minutes thereafter, and then set notch is commenced (Hot adjust control).
Indoor unit remote controller shows "H0" or "PLEASE WAIT" indicator for about five minutes when turning ON universal power supply.	"H0" or "PLEASE WAIT" flashes	The system is being started up. Operate remote controller again after "H0" or "PLEASE WAIT" disappears.
Drain pump does not stop when unit is stopped.	Light out	After cooling operation stops, the unit continues to operate drain pump for three minutes and then stops it.
Drain pump continues to operate while unit has been stopped.		Unit continues to operate drain pump if drainage is generated, even after the unit has been stopped.
Indoor unit emits noise when switching from heating to cooling and vice versa.	Normal display	This is a switching sound of the refrigerant circuit and does not imply a problem.
Immediately after startup, the indoor unit emits the sound of the refrigerant flow.	Normal display	Unstable flow of the refrigerant emits a sound. This is temporary and does not imply a problem.
Warm air comes from an indoor unit that is not performing a heating operation.	Normal display	The LEV is slightly open to prevent refrigerant, of the indoor unit that is not performing the heating operation, from being liquefied. This does not imply a problem.

13. Information on rating plate

Model	WP200YJM-A	WP250YJM-A
Refrigerant (R410A)	11.8 kg	11.8 kg
Allowable pressure (Ps)	HP: 4.15 MPa, LP: 2.21 MPa	
Net weight	270 kg	270 kg

MANUFACTURER: MITSUBISHI ELECTRIC CORPORATION
AIR-CONDITIONING & REFRIGERATION SYSTEMS WORKS 5-66, TEBIRA, 6-CHOME, WAKAYAMA CITY, JAPAN

This product is designed and intended for use in the residential,
commercial and light-industrial environment.

The product at hand is
based on the following
EU regulations:

- Low Voltage Directive 2006/95/EC
- Electromagnetic Compatibility Directive 2004/108/EC
- Pressure Equipment Directive 97/23/EC
- Machinery Directive 2006/42/EC

Please be sure to put the contact address/telephone number on
this manual before handing it to the customer.

mitsubishi electric corporation

HEAD OFFICE: TOKYO BLDG., 2-7-3, MARUNOUCHI, CHIYODA-KU, TOKYO 100-8310, JAPAN
Authorized representative in EU: MITSUBISHI ELECTRIC EUROPE B.V.

HARMAN HOUSE, 1 GEORGE STREET, UXBRIDGE, MIDDLESEX UB8 1QQ, U.K.