

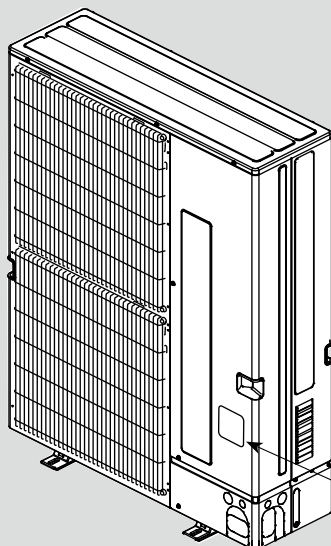

PARTS CATALOG

<Outdoor unit>
[Model Name]
PUMY-P112VKM1
PUMY-P125VKM1
PUMY-P140VKM1
PUMY-P112YKM1
PUMY-P125YKM1
PUMY-P140YKM1
Salt proof model
PUMY-P112VKM1-BS
PUMY-P125VKM1-BS
PUMY-P140VKM1-BS
PUMY-P112YKM1-BS
PUMY-P125YKM1-BS
PUMY-P140YKM1-BS
[Service Ref.]
PUMY-P112VKM1
PUMY-P125VKM1
PUMY-P140VKM1
PUMY-P112YKM1
PUMY-P125YKM1
PUMY-P140YKM1
PUMY-P112VKM1-BS
PUMY-P125VKM1-BS
PUMY-P140VKM1-BS
PUMY-P112YKM1-BS
PUMY-P125YKM1-BS
PUMY-P140YKM1-BS
Note:

- ROHS compliant products have <G> mark on spec name plate.

 Model name
indication

OUTDOOR UNIT
CONTENTS

- | | |
|-------------------------|---|
| 1. RoHS PARTS LIST..... | 3 |
| 2. OPTIONAL PARTS..... | 8 |

SERVICE MANUAL (OCH576)

1-1. STRUCTURAL PARTS

PUMY-P112VKM1

PUMY-P112VKM1-BS

PUMY-P125VKM1

PUMY-P125VKM1-BS

PUMY-P140VKM1

PUMY-P140VKM1-BS

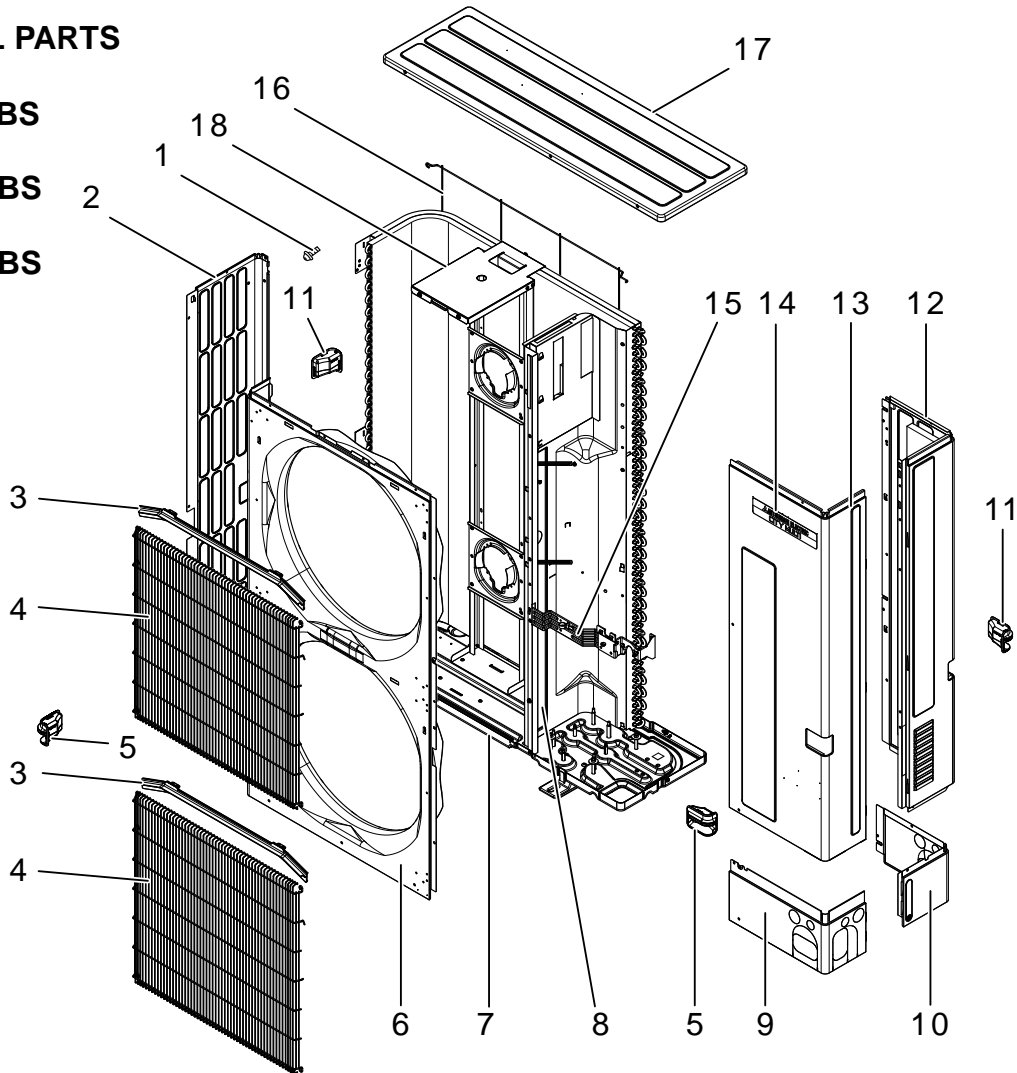

No.	RoHS	Parts No.	Parts Name	Specification	Q'ty/unit						Remarks (Drawing No.)	Wiring Diagram Symbol
					PUMY-P112VKM1	PUMY-P112VKM1-BS	PUMY-P125VKM1	PUMY-P125VKM1-BS	PUMY-P140VKM1	PUMY-P140VKM1-BS		
1	G	—	F. ST SCREW	(5x12)	40	40	40	40	40	40	(DG12F536H12)	
2	G	R01 E30 662	SIDE PANEL(L)		1	1	1	1	1	1		
3	G	R01 E02 631	ICE GUARD		2	2	2	2	2	2		
4	G	R01 E73 691	WIRE GRILLE		2	2	2	2	2	2		
5	G	R01 E05 655	HANDLE(FRONT)		2	2	2	2	2	2		
6	G	R01 E23 668	FRONT PANEL		1	1	1	1	1	1		
7	G	R01 E53 686	BASE ASSY		1	1	1	1	1	1		
8	G	—	SEPARATOR		1	1	1	1	1	1	(BK00B817GH9)	
9	G	R01 E41 658	COVER PANEL(FRONT)		1	1	1	1	1	1		
10	G	R01 E34 658	COVER PANEL(REAR)		1	1	1	1	1	1		
11	G	R01 E06 655	HANDLE(REAR)		2	2	2	2	2	2		
12	G	R01 E55 661	SIDE PANEL(R)		1	1	1	1	1	1		
13	G	T7W E20 668	SERVICE PANEL		1	1	1	1	1	1		
14	G	—	LABEL(CITY MULTI)		1	1	1	1	1	1	(BH79T094H02)	
15	G	—	VALVE BED		1	1	1	1	1	1	(BK00C375G10)	
16	G	R01 E10 698	REAR GUARD		1	1	1	1	1	1		
17	G	R01 E36 641	TOP PANEL		1	1	1	1	1	1		
18	G	R01 E56 130	MOTOR SUPPORT		1	1	1	1	1	1		

RoHS PARTS LIST

STRUCTURAL PARTS
PUMY-P112YKM1
PUMY-P112YKM1-BS
PUMY-P125YKM1
PUMY-P125YKM1-BS
PUMY-P140YKM1
PUMY-P140YKM1-BS

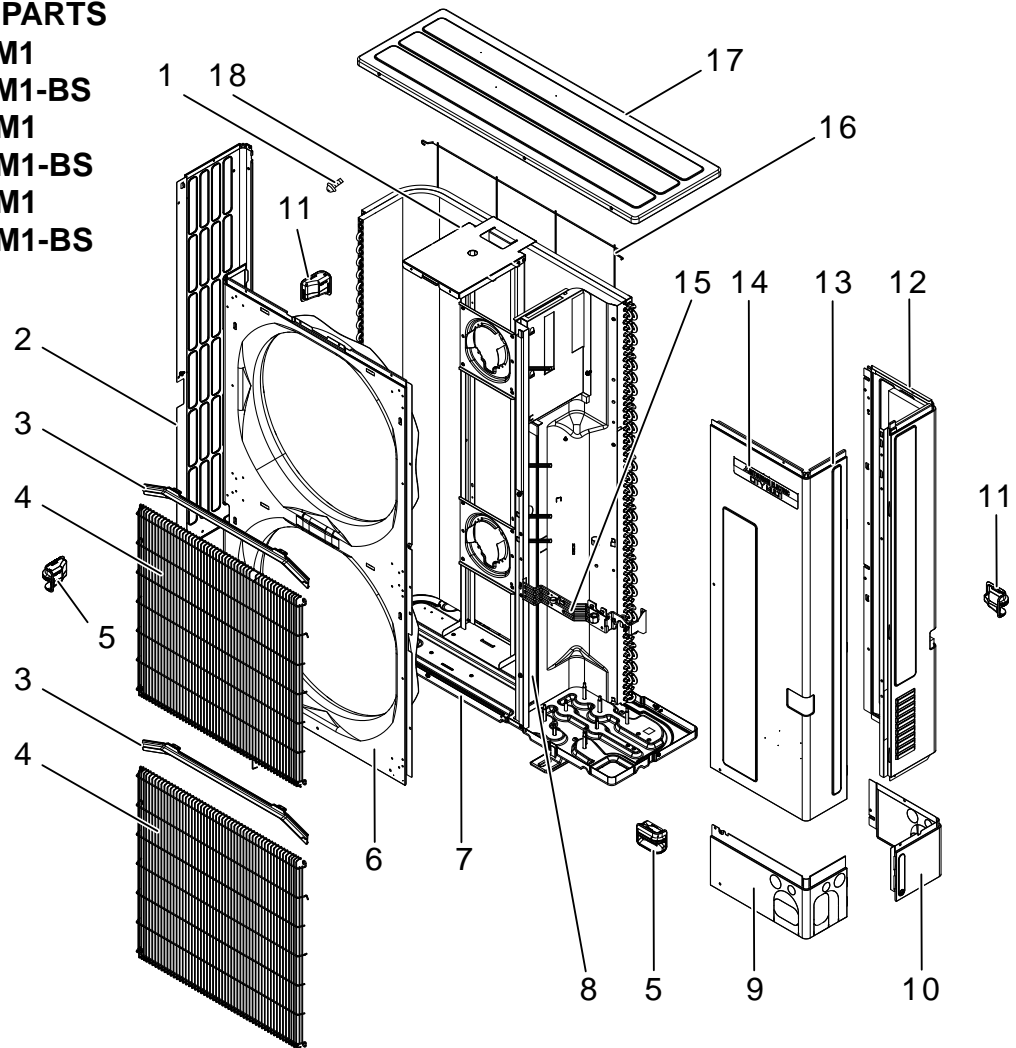

No.	RoHS	Parts No.	Parts Name	Specification	Q'ty/unit						Remarks (Drawing No.)	Wiring Diagram Symbol
					PUMY-P112YKM1	PUMY-P112YKM1-BS	PUMY-P125YKM1	PUMY-P125YKM1-BS	PUMY-P140YKM1	PUMY-P140YKM1-BS		
1	G	—	F. ST SCREW	(5X12)	40	40	40	40	40	40	(DG12F536H12)	
2	G	R01 E30 662	SIDE PANEL(L)		1	1	1	1	1	1		
3	G	R01 E02 631	ICE GUARD		2	2	2	2	2	2		
4	G	R01 E73 691	WIRE GRILLE		2	2	2	2	2	2		
5	G	R01 E05 655	HANDLE(FRONT)		2	2	2	2	2	2		
6	G	R01 E23 668	FRONT PANEL		1	1	1	1	1	1		
7	G	R01 E53 686	BASE ASSY		1	1	1	1	1	1		
8	G	—	SEPARATOR		1	1	1	1	1	1	(BK00B817GH7)	
9	G	R01 E41 658	COVER PANEL(FRONT)		1	1	1	1	1	1		
10	G	R01 E34 658	COVER PANEL(REAR)		1	1	1	1	1	1		
11	G	R01 E06 655	HANDLE(REAR)		2	2	2	2	2	2		
12	G	T7W E37 661	SIDE PANEL(R)		1	1	1	1	1	1		
13	G	T7W E21 667	SERVICE PANEL		1	1	1	1	1	1		
14	G	—	LABEL(CITY MULTI)		1	1	1	1	1	1	(BH79T094H02)	
15	G	—	VALVE BED		1	1	1	1	1	1	(BK00C375G10)	
16	G	R01 E10 698	REAR GUARD		1	1	1	1	1	1		
17	G	R01 E36 641	TOP PANEL		1	1	1	1	1	1		
18	G	R01 E56 130	MOTOR SUPPORT		1	1	1	1	1	1		

RoHS PARTS LIST

1-2. FUNCTIONAL PARTS

PUMY-P112VKM1
 PUMY-P112VKM1-BS
 PUMY-P125VKM1
 PUMY-P125VKM1-BS
 PUMY-P140VKM1
 PUMY-P140VKM1-BS

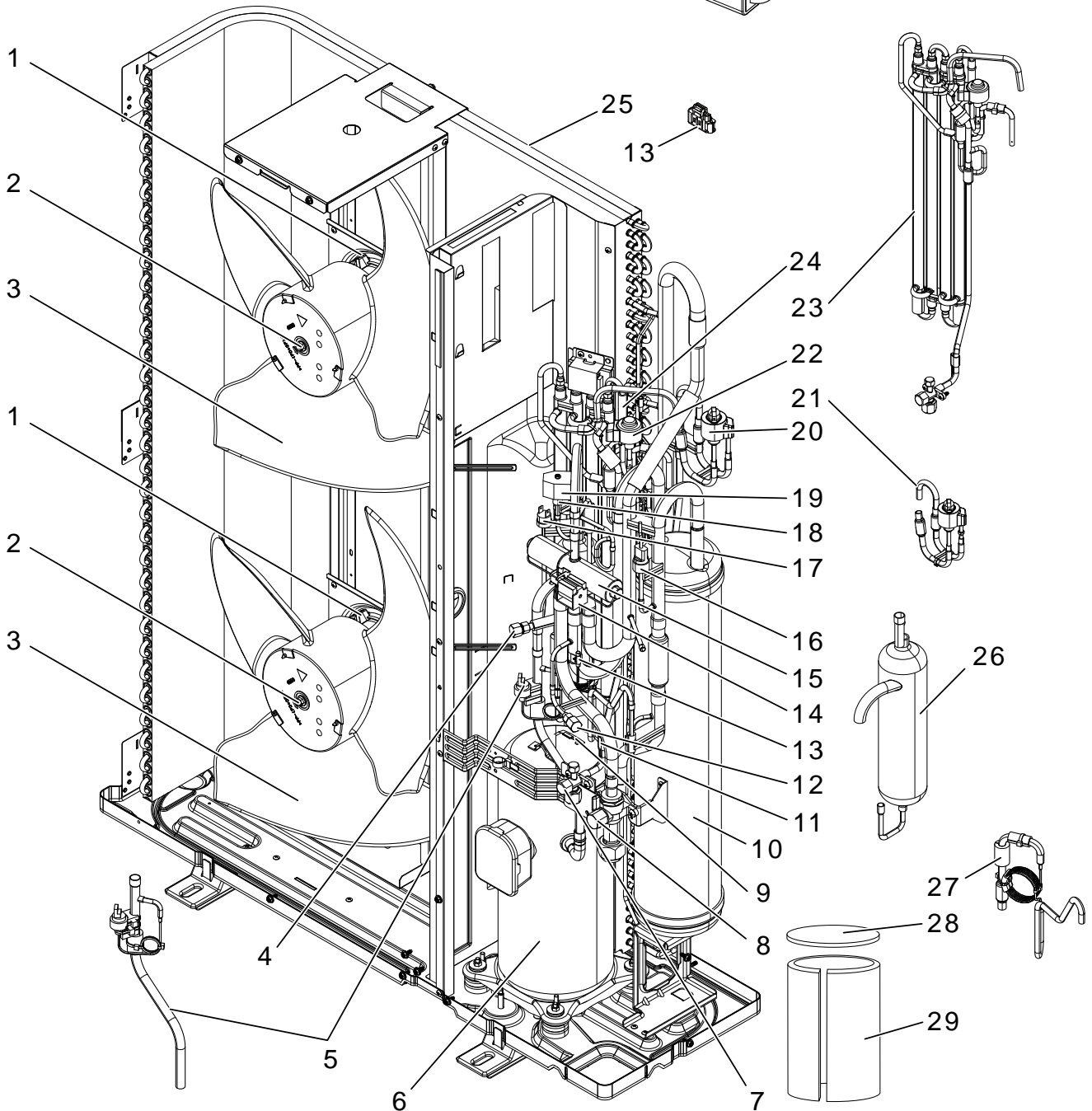
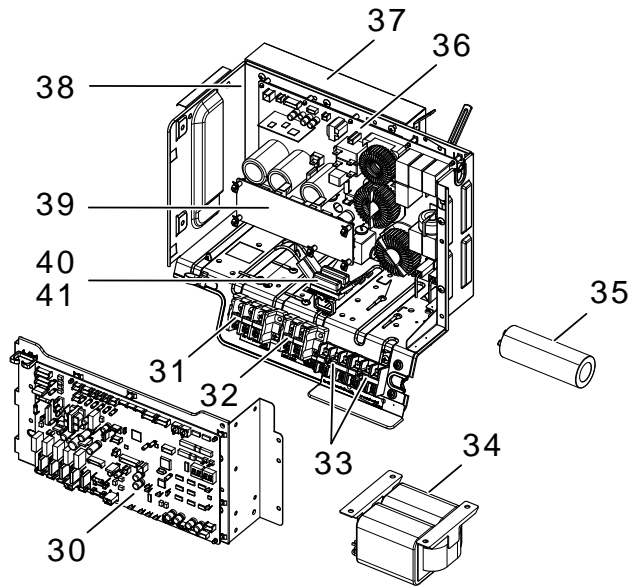

RoHS PARTS LIST

Part numbers that are circled are not shown in the figure.

No.	RoHS	Parts No.	Parts Name	Specification	Q'ty/unit						Remarks (Drawing No.)	Wiring Diagram Symbol
					PUMY-P112VKM1	PUMY-P112VKM1-BS	PUMY-P125VKM1	PUMY-P125VKM1-BS	PUMY-P140VKM1	PUMY-P140VKM1-BS		
1	G	R01 E59 221	FAN MOTOR		2	2	2	2	2	2		MF1, MF2
2	G	R01 E09 097	NUT		2	2	2	2	2	2		
3	G	R01 E14 115	PROPELLER FAN		2	2	2	2	2	2		
4	G	R01 E18 413	CHARGE PLUG		1	1	1	1	1	1		
5	G	R01 E11 208	HIGH PRESSURE SENSOR ASSY		1	1	1	1	1	1		63HS
6	G	T97 435 077	COMPRESSOR	ANB33FNHMT	1	1	1	1	1	1	Including RUBBERMOUNT	MC
7	G	R01 E25 410	STOP VALVE 3/8F	3/8	1	1	1	1	1	1		
8	G	R01 E11 411	BALL VALVE 5/8F	5/8	1	1	1	1	1	1		
9	G	R01 E30 201	THERMISTOR	Compressor	1	1	1	1	1	1		TH4
10	G	R01 E73 440	ACCUMULATOR		1	1	1	1	1	1		
11	G	R01 H97 202	THERMISTOR	HIC Pipe	1	1	1	1	1	1		TH2
12	G	R01 E24 413	CHARGE PLUG		1	1	1	1	1	1		
13	G	R01 H99 202	THERMISTOR	Suction Pipe, Ambient	1	1	1	1	1	1	Combined Port	TH6, TH7
14	G	T7W E66 242	SOLENOID COIL		1	1	1	1	1	1		21S4
15	G	R01 E39 403	4 WAY VALVE		1	1	1	1	1	1		
16	G	R01 E03 209	LOW PRESSURE SENSOR		1	1	1	1	1	1		63LS
17	G	R01 E06 208	HIGH PRESSURE SWITCH		1	1	1	1	1	1		63H
18	G	R01 E14 428	SOLENOID VALVE	Bypass Valve (SV1)	1	1	1	1	1	1		
19	G	T7W E67 242	SOLENOID COIL		1	1	1	1	1	1	GRAY	SV1
20	G	R01 H21 242	LEV COIL	UKV type	1	1	1	1	1	1	WHITE	LEV-A
21	G	R01H63 401	LEV-A ASSY		1	1	1	1	1	1	Including LEV COIL	
22	G	R01 H22 242	LEV COIL	CAM type	1	1	1	1	1	1	RED	LEV-B
23	G	R01 H64 401	LEV-B ASSY		1	1	1	1	1	1	Including LEV COIL and STOP VALVE	
24	G	R01 H87 202	THERMISTOR	Outdoor Liquid Pipe	1	1	1	1	1	1		TH3
25	G	R01 H48 408	HEAT EXCHANGER		1	1	1	1	1	1		
26	G	R01E15 490	OIL SEPARATOR		1	1	1	1	1	1		
27	G	R01 E00 426	CT ASSY		1	1	1	1	1	1		
28	G	R01 A57 602	COMP FELT(TOP)		1	1	1	1	1	1		
29	G	R01 A71 602	COMP FELT(BODY)		1	1	1	1	1	1		
30	G	R01 AM2 350	OUTDOOR MULTI CONTROLLER CIRCUIT BOARD		1	1	1	1	1	1		MULTI.B.
31	G	T7W A15 716	TERMINAL BLOCK	3P(L,N,⊕)	1	1	1	1	1	1		TB1
32	G	T7W E57 716	TERMINAL BLOCK	2P(B1,B2)	1	1	1	1	1	1		TB1B
33	G	R01 E27 246	TERMINAL BLOCK	3P(M1,M2,S)	2	2	2	2	2	2		TB3, TB7
34	G	R01 E51 259	REACTOR		1	1	1	1	1	1		DCL
35	G	R01 E20 254	MAIN SMOOTHING CAPACITOR		1	1	1	1	1	1		CB
36	G	R01 A40 353	POWER CIRCUIT BOARD		1	1	1	1	1	1		P.B.
37	G	R01 A10 371	HEAT SINK		1	1	1	1	1	1		
38	G	—	ELECTRICAL PARTS BOX		1	1	1	1	1	1	(BK00L626G10)	
39	G	R01 E06 311	M-NET POWER CIRCUIT BOARD		1	1	1	1	1	1		M-NET P.B.
40	G	R01 E20 239	FUSE	20A 250V	2	2	2	2	2	2		FUSE1, FUSE2
41	G	R01 30L 241	FUSE HOLDER		2	2	2	2	2	2		
42	G	R01 E30 510	LEAD ASSY COMP		1	1	1	1	1	1		
43	G	R01 E14 239	FUSE	6.3A 250V	2	2	2	2	2	2		F1, F2

RoHS PARTS LIST

FUNCTIONAL PARTS
PUMY-P112YKM1
PUMY-P112YKM1-BS
PUMY-P125YKM1
PUMY-P125YKM1-BS
PUMY-P140YKM1
PUMY-P140YKM1-BS

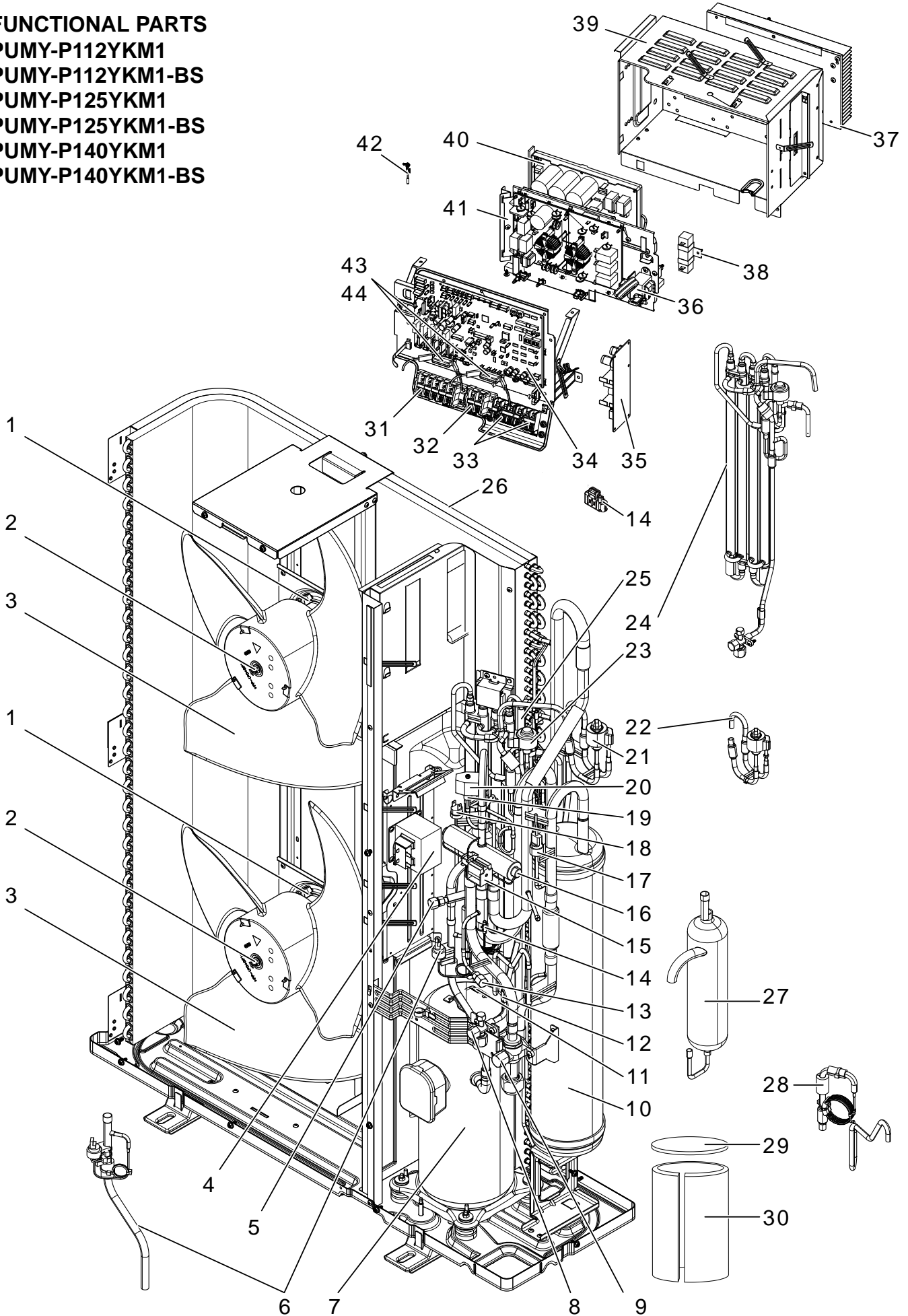

RoHS PARTS LIST

Parts numbers that are circled are not shown in the figure.

No.	ROHS	Parts No.	Parts Name	Specification	Q'ty/unit						Remarks (Drawing No.)	Wiring Diagram Symbol
					PJMY-P112YKM1	PJMY-P112YKM1-BS	PJMY-P125YKM1	PJMY-P125YKM1-BS	PJMY-P140YKM1	PJMY-P140YKM1-BS		
1	G	R01 E59 221	FAN MOTOR		2	2	2	2	2	2		MF1,MF2
2	G	R01 E09 097	NUT		2	2	2	2	2	2		
3	G	R01 E14 115	PROPELLER FAN		2	2	2	2	2	2		
4	G	R01 E50 259	REACTOR		1	1	1	1	1	1		DCL
5	G	R01 E18 413	CHARGE PLUG		1	1	1	1	1	1		
6	G	R01 E11 208	HIGH PRESSURE SENSOR ASSY		1	1	1	1	1	1		63HS
7	G	T97 434 077	COMPRESSOR	ANB33FNGMT	1	1	1	1	1	1	Including RUBBERMOUNT	MC
8	G	R01 E25 410	STOP VALVE 3/8F	3/8	1	1	1	1	1	1		
9	G	R01 E11 411	BALL VALVE 5/8F	5/8	1	1	1	1	1	1		
10	G	R01 E73 440	ACCUMULATOR		1	1	1	1	1	1		
11	G	R01 E30 201	THERMISTOR	Compressor	1	1	1	1	1	1		TH4
12	G	R01 H97 202	THERMISTOR	HIC Pipe	1	1	1	1	1	1		TH2
13	G	R01 E24 413	CHARGE PLUG		1	1	1	1	1	1		
14	G	R01 H98 202	THERMISTOR	Suction Pipe, Ambient	1	1	1	1	1	1	Combined Port	TH6,TH7
15	G	T7W E68 242	SOLENOID COIL		1	1	1	1	1	1		21S4
16	G	R01 E39 403	4WAY VALVE		1	1	1	1	1	1		
17	G	R01 E03 209	LOW PRESSURE SENSOR		1	1	1	1	1	1		63LS
18	G	R01 E06 208	HIGH PRESSURE SWITCH		1	1	1	1	1	1		63H
19	G	R01 E14 428	SOLENOID VALVE	Bypass Valve(SV1)	1	1	1	1	1	1		
20	G	T7W E67 242	SOLENOID COIL		1	1	1	1	1	1	GRAY	SV1
21	G	R01 H21 242	LEV COIL	UKV type	1	1	1	1	1	1	WHITE	LEV-A
22	G	R01 H63 401	LEV-A ASSY		1	1	1	1	1	1	Including LEV COIL	
23	G	R01 H22 242	LEV COIL	CAM type	1	1	1	1	1	1	RED	LEV-B
24	G	R01 H64 401	LEV-B ASSY		1	1	1	1	1	1	Including LEV COIL and STOP VALVE	
25	G	R01 H87 202	THERMISTOR	Outdoor Liquid Pipe	1	1	1	1	1	1		TH3
26	G	R01 H48 408	HEAT EXCHANGER		1	1	1	1	1	1		
27	G	R01 E15 490	OIL SEPARATOR		1	1	1	1	1	1		
28	G	R01 E00 426	CT ASSY		1	1	1	1	1	1		
29	G	R01 A57 602	COMP FELT(TOP)		1	1	1	1	1	1		
30	G	R01 A71 602	COMP FELT(BODY)		1	1	1	1	1	1		
31	G	T7W E30 716	TERMINAL BLOCK	5P(L1,L2,L3,N,⊕)	1	1	1	1	1	1		TB1
32	G	T7W E57 716	TERMINAL BLOCK	2P(B1,B2)	1	1	1	1	1	1		TB1B
33	G	R01 E27 246	TERMINAL BLOCK	3P(M1,M2,S)	2	2	2	2	2	2		TB3,TB7
34	G	R01 AM2 350	OUTDOOR MULTI CONTROLLER CIRCUIT BOARD		1	1	1	1	1	1		MULTI.B.
35	G	R01 E06 311	M-NET POWER CIRCUIT BOARD		1	1	1	1	1	1		M-NET P.B.
36	G	R01 E31 259	REACTOR		1	1	1	1	1	1		ACL4
37	G	R01 A11 371	HEAT SINK		1	1	1	1	1	1		
38	G	R01 E10 233	RESISTOR		1	1	1	1	1	1		RS
39	G	—	ELECTRICAL PARTS BOX		1	1	1	1	1	1	(BK00C410G20)	
40	G	T7W A60 323	POWER CIRCUIT BOARD		1	1	1	1	1	1		P.B.
41	G	T7W E31 346	NOISE FILTER CIRCUIT BOARD		1	1	1	1	1	1		N.F.
42	G	R01 H93 202	THERMISTOR	Heat sink	1	1	1	1	1	1		TH8
43	G	R01 E20 239	FUSE	20A 250V	2	2	2	2	2	2		FUSE1, FUSE2
44	G	R01 30L 241	FUSE HOLDER		2	2	2	2	2	2		
45	G	R01 E31 510	LEAD ASSY COMP		1	1	1	1	1	1		
46	G	R01 E14 239	FUSE	6.3A 250V	2	2	2	2	2	2		F1, F2

2

OPTIONAL PARTS

DRAIN SOCKET

Parts No.	PAC-SG61DS-E
-----------	--------------

AIR OUTLET GUIDE

Parts No.	PAC-SH96SG-E
-----------	--------------

Note: Need 2 pieces.

AIR GUIDE

Parts No.	PAC-SH95AG-E
-----------	--------------

Note: Need 2 pieces.

DRAIN PAN

Parts No.	PAC-SH97DP-E
-----------	--------------

BRANCH PIPE (Joint)

Parts No.	NUMBER OF BRANCHING POINTS
CMY-Y62-G-E	2
CMY-Y64-G-E	4
CMY-Y68-G-E	8

JOINT PIPE (Unit→Extension pipe)

Parts No.	PAC-SG73RJ-E ($\phi 9.52 \rightarrow \phi 12.7$)
	PAC-SG75RJ-E ($\phi 15.88 \rightarrow \phi 19.05$)

Base Heater

Parts No.	PAC-SJ20BH-E
-----------	--------------

CONNECTION KIT

Parts No.	PAC-LV11M-J
-----------	-------------

BRANCH BOX

Parts No.	PAC-MK30BC
	PAC-MK50BC

MITSUBISHI ELECTRIC CORPORATION

HEAD OFFICE : TOKYO BLDG., 2-7-3, MARUNOUCHI, CHIYODA-KU, TOKYO 100-8310, JAPAN