

SERVICE PARTS LIST FOR MITSUBISHI ELECTRIC PACKAGED AIR-CONDITIONERS

Series : PUHY-(E)P•Y(S)JM-A(-BS)

For use with the R410A

REVISED

July 2013

BWE1010B

INDEX

PUHY-P200YJM-A(-BS)

PUHY-P250YJM-A(-BS)

PUHY-P300YJM-A(-BS)

PUHY-P350YJM-A(-BS)

PUHY-P400YJM-A(-BS)

PUHY-P450YJM-A(-BS)

PUHY-EP200YJM-A(-BS)

PUHY-EP250YJM-A(-BS)

PUHY-EP300YJM-A(-BS)

Refer to the next page for the package names.

Part information update day : **2013/07/25**

Please change the old catalog (issued Apr. 2013, No.BWE1010A) to this new catalog.
Content of revision : Some of parts are changed.



The Package name list

PUHY-P500YSJM-A(-BS)	[PUHY-P250YJM-A(-BS)+PUHY-P250YJM-A(-BS)]
PUHY-P500YSJM-A1(-BS)	[PUHY-P300YJM-A(-BS)+PUHY-P200YJM-A(-BS)]
PUHY-P550YSJM-A(-BS)	[PUHY-P300YJM-A(-BS)+PUHY-P250YJM-A(-BS)]
PUHY-P600YSJM-A(-BS)	[PUHY-P350YJM-A(-BS)+PUHY-P250YJM-A(-BS)]
PUHY-P600YSJM-A1(-BS)	[PUHY-P300YJM-A(-BS)+PUHY-P300YJM-A(-BS)]
PUHY-P650YSJM-A(-BS)	[PUHY-P350YJM-A(-BS)+PUHY-P300YJM-A(-BS)]
PUHY-P700YSJM-A(-BS)	[PUHY-P350YJM-A(-BS)+PUHY-P350YJM-A(-BS)]
PUHY-P700YSJM-A1(-BS)	[PUHY-P400YJM-A(-BS)+PUHY-P300YJM-A(-BS)]
PUHY-P750YSJM-A(-BS)	[PUHY-P400YJM-A(-BS)+PUHY-P350YJM-A(-BS)]
PUHY-P800YSJM-A(-BS)	[PUHY-P450YJM-A(-BS)+PUHY-P350YJM-A(-BS)]
PUHY-P800YSJM-A1(-BS)	[PUHY-P400YJM-A(-BS)+PUHY-P400YJM-A(-BS)]
PUHY-P850YSJM-A(-BS)	[PUHY-P450YJM-A(-BS)+PUHY-P400YJM-A(-BS)]
PUHY-P900YSJM-A(-BS)	[PUHY-P450YJM-A(-BS)+PUHY-P450YJM-A(-BS)]
PUHY-P950YSJM-A(-BS)	[PUHY-P400YJM-A(-BS)+PUHY-P300YJM-A(-BS)+PUHY-P250YJM-A(-BS)]
PUHY-P1000YSJM-A(-BS)	[PUHY-P400YJM-A(-BS)+PUHY-P300YJM-A(-BS)+PUHY-P300YJM-A(-BS)]
PUHY-P1050YSJM-A(-BS)	[PUHY-P400YJM-A(-BS)+PUHY-P350YJM-A(-BS)+PUHY-P300YJM-A(-BS)]
PUHY-P1100YSJM-A(-BS)	[PUHY-P400YJM-A(-BS)+PUHY-P350YJM-A(-BS)+PUHY-P350YJM-A(-BS)]
PUHY-P1150YSJM-A(-BS)	[PUHY-P450YJM-A(-BS)+PUHY-P350YJM-A(-BS)+PUHY-P350YJM-A(-BS)]
PUHY-P1200YSJM-A(-BS)	[PUHY-P450YJM-A(-BS)+PUHY-P400YJM-A(-BS)+PUHY-P350YJM-A(-BS)]
PUHY-P1250YSJM-A(-BS)	[PUHY-P450YJM-A(-BS)+PUHY-P450YJM-A(-BS)+PUHY-P350YJM-A(-BS)]
PUHY-EP400YSJM-A(-BS)	[PUHY-EP200YJM-A(-BS)+PUHY-EP200YJM-A(-BS)]
PUHY-EP450YSJM-A(-BS)	[PUHY-EP250YJM-A(-BS)+PUHY-EP200YJM-A(-BS)]
PUHY-EP500YSJM-A(-BS)	[PUHY-EP300YJM-A(-BS)+PUHY-EP200YJM-A(-BS)]
PUHY-EP500YSJM-A1(-BS)	[PUHY-EP250YJM-A(-BS)+PUHY-EP250YJM-A(-BS)]
PUHY-EP550YSJM-A(-BS)	[PUHY-EP300YJM-A(-BS)+PUHY-EP250YJM-A(-BS)]
PUHY-EP600YSJM-A(-BS)	[PUHY-EP300YJM-A(-BS)+PUHY-EP300YJM-A(-BS)]
PUHY-EP650YSJM-A(-BS)	[PUHY-EP250YJM-A(-BS)+PUHY-EP200YJM-A(-BS)+PUHY-EP200YJM-A(-BS)]
PUHY-EP700YSJM-A(-BS)	[PUHY-EP300YJM-A(-BS)+PUHY-EP200YJM-A(-BS)+PUHY-EP200YJM-A(-BS)]
PUHY-EP700YSJM-A1(-BS)	[PUHY-EP250YJM-A(-BS)+PUHY-EP250YJM-A(-BS)+PUHY-EP200YJM-A(-BS)]
PUHY-EP750YSJM-A(-BS)	[PUHY-EP300YJM-A(-BS)+PUHY-EP250YJM-A(-BS)+PUHY-EP200YJM-A(-BS)]
PUHY-EP750YSJM-A1(-BS)	[PUHY-EP250YJM-A(-BS)+PUHY-EP250YJM-A(-BS)+PUHY-EP250YJM-A(-BS)]
PUHY-EP800YSJM-A(-BS)	[PUHY-EP300YJM-A(-BS)+PUHY-EP300YJM-A(-BS)+PUHY-EP200YJM-A(-BS)]
PUHY-EP800YSJM-A1(-BS)	[PUHY-EP300YJM-A(-BS)+PUHY-EP250YJM-A(-BS)+PUHY-EP250YJM-A(-BS)]
PUHY-EP850YSJM-A(-BS)	[PUHY-EP300YJM-A(-BS)+PUHY-EP300YJM-A(-BS)+PUHY-EP250YJM-A(-BS)]
PUHY-EP900YSJM-A(-BS)	[PUHY-EP300YJM-A(-BS)+PUHY-EP300YJM-A(-BS)+PUHY-EP300YJM-A(-BS)]

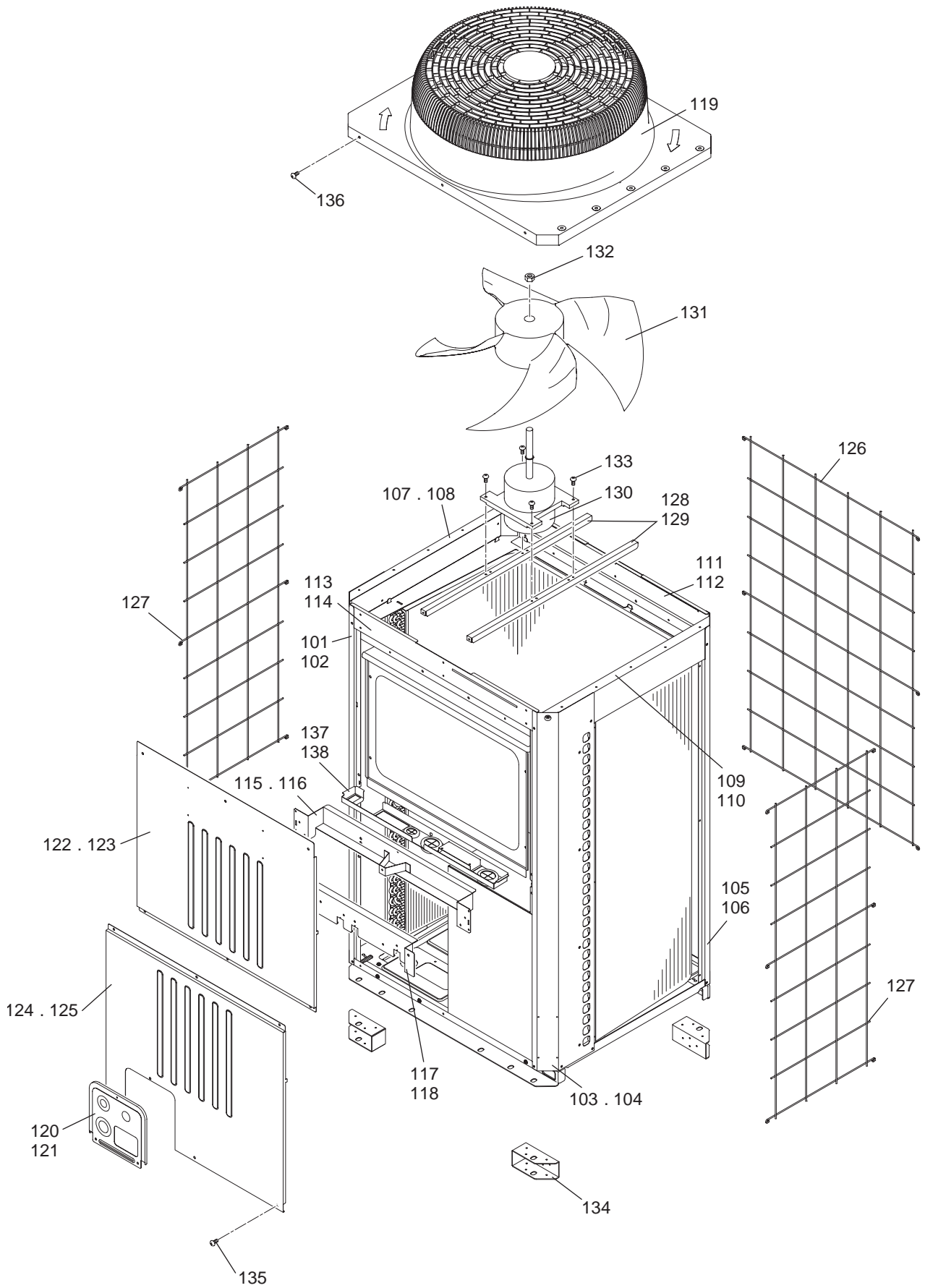

**PUHY-P350,P400YJM-A(-BS)
PUHY-EP250YJM-A(-BS)**

EXTERNAL PARTS & BLOWER PARTS (2)

No.	Part No.	G : RoHS Apply Only W : RoHS Apply by Running Change	Part Name	Spec.	PUHY-P350YJM-A	PUHY-P350YJM-A-BS	PUHY-P400YJM-A	PUHY-P400YJM-A-BS	PUHY-EP250YJM-A	PUHY-EP250YJM-A-BS	Dwg. No.	Notes for the models	Revision info.
202	R11 020 626	G	Pillar LF	BS		1	1		1		KB02A011G08		
203	R11 014 626	G	Pillar RF		1		1		1		KB02A012G07		
204	R11 015 626	G	Pillar RF	BS		1	1		1		KB02A012G08		
205	R63 002 627	G	Pillar B		2		2		2		KB02A013G07		
206	R63 003 627	G	Pillar B	BS		2	2		2		KB02A013G08		
207	R63 038 162	G	Frame assy L		1		1		1		KD00G100G01		
208	R63 040 162	G	Frame assy L	BS		1	1		1		KD00G100G02		
209	R63 039 162	G	Frame assy R		1		1		1		KD00G101G01		
210	R63 041 162	G	Frame assy R	BS		1	1		1		KD00G101G02		
211	R63 019 111	G	Frame assy B	18	1		1		1		KB00C464G03		
212	R63 020 111	G	Frame assy B	18 BS		1	1		1		KB00C464G04		
213	R63 021 111	G	Frame F	18HP	1		1		1		KB02B093H03		
214	R63 022 111	G	Frame FB	18HP BS		1	1		1		KB02B093G05		
215	R61 031 162	G	Frame assy MU	18	1		1		1		KB00T829G01		
216	R61 033 162	G	Frame assy MU	18 BS		1	1		1		KB00T829G03		
217	R61 006 162	G	Frame assy MB	18	1		1		1		KB00L186G01		
218	R61 008 162	G	Frame assy MB	18 BS		1	1		1		KB00L186G07		
219	R63 4H6 118	G	Fan guard		1	1	1	1	1	1	KB25A008H07		
220	R11 003 077	G	Piping cover		1		1		1		KB02C040G06		
221	R11 004 077	G	Piping cover	BS		1	1		1		KB02C040G07		
222	R61 051 651	G	Panel FU	18HP	1		1		1		KB02B402H02		
223	R63 7H8 651	G	Panel FU	18HP BS		1	1		1		KB02B402G04		
224	R61 005 652	G	Panel FB	18HP YHM-A	1		1		1		KB02B403H02		
225	R61 006 652	G	Panel FB	18HP YHM BS		1	1		1		KB02B403G03		
226	R61 003 118	G	Fin guard B	18HP	1	1	1	1	1	1	KB07T209G01		
227	R61 007 611	G	Fin guard LR		2	2	2	2	2	2	KB07C043G03		
228	R63 7H6 118	G	Fan guard cover		2	2	2	2	2	2	KB25B086H03		
229	R63 4H6 140	G	Base fan		2		2		2		KB02D050H01		
230	R63 4H7 140	G	Base fan	BS		2	2		2		KB02D050G03		
231	R61 122 220	G	Motor	YC920IA	1	1	1	1	1	1	P780109X03		
232	R63 4H6 300	G	Fan		1	1	1	1	1	1	KB25A009H03		
233	R63 4H6 122	G	Box nut	M12 CH	1	1	1	1	1	1	P552000X01		
234	R63 014 087	G	Upset screw	6 x 10	4	4	4	4	4	4	P516047X01		
235	R61 016 130	G	Attachment leg		4	4	4	4	4	4	KD02T773G01		
236	R63 007 087	G	H Screw	5 x 10 KNURLED (30 pcs)	4	4	4	4	4	4	KB00H418G14		
237	R63 006 087	G	WFT Screw	5 x 12 (30 pcs)	2	2	2	2	2	2	KB00H418G01		
238	R61 001 261	G	Snow guard assy		1		1		1		KB00M950G11		
239	R61 T01 012	G	Snow guard assy	BS		1	1		1		KB00M950G12		

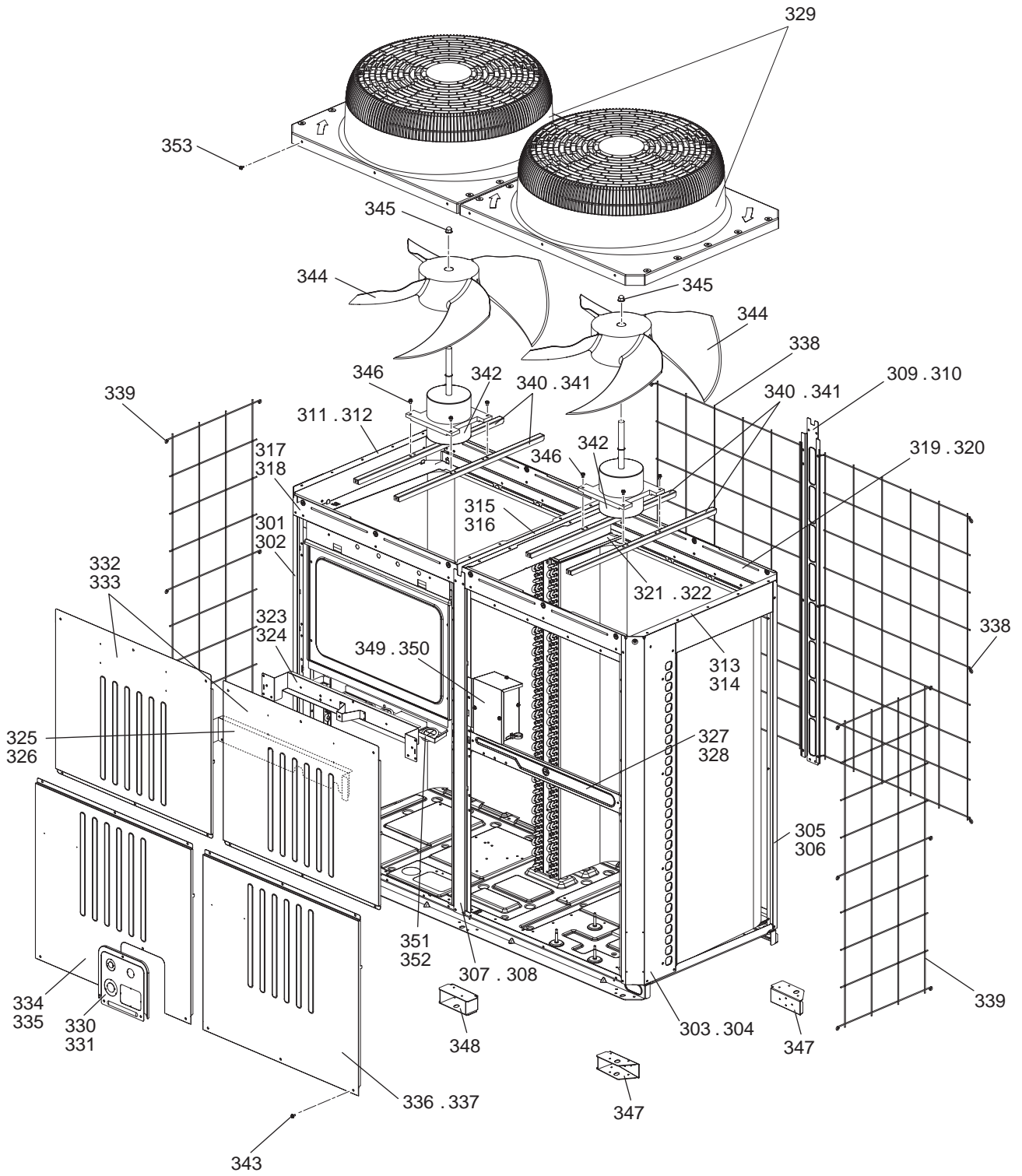

No.	Part No.	G : RoHS Apply Only W : RoHS Apply by Running Change	Part Name	Spec.	PUHY-P450YJM-A	PUHY-P460YJM-A-BS	PUHY-EP300YJM-A	PUHY-EP300YJM-A-BS		Dwg. No.	Notes for the models	Revision info.
302	R61 010 626	G	Pillar LF	XL BS		1	1			KB02A011G10		
303	R11 014 626	G	Pillar RF		1	1				KB02A012G07		
304	R11 015 626	G	Pillar RF	BS		1	1			KB02A012G08		
305	R63 002 627	G	Pillar B		2	2				KB02A013G07		
306	R63 003 627	G	Pillar B	BS		2	2			KB02A013G08		
307	R61 015 626	G	Pillar assy MF		1	1				KD00C356G05		
308	R61 016 626	G	Pillar assy MF	BS		1	1			KD00C356G06		
309	R61 011 626	G	Pillar MB		1	1				KB02A263G01		
310	R61 012 626	G	Pillar MB	BS		1	1			KB02A263G02		
311	R63 038 162	G	Frame assy L		1	1				KD00G100G01		
312	R63 040 162	G	Frame assy L	BS		1	1			KD00G100G02		
313	R63 039 162	G	Frame assy R		1	1				KD00G101G01		
314	R63 041 162	G	Frame assy R	BS		1	1			KD00G101G02		
315	R61 054 162	G	Frame M		1	1				KD00G287G01		
316	R61 055 162	G	Frame M	BS		1	1			KD00G287G02		
317	R61 048 162	G	Frame F	XL	1	1				KB02A264H01		
318	R61 049 162	G	Frame FB	XL BS		1	1			KB02A264G03		
319	R61 042 162	G	Frame assy B	XL	1	1				KD00C265G01		
320	R61 043 162	G	Frame assy B	XL BS		1	1			KD00C265G04		
321	R61 003 499	G	Plate HEX assy	XL	1	1				KB00T714G01		
322	R61 004 499	G	Plate HEX assy	XL BS		1	1			KB00T714G02		
323	R63 013 111	G	Frame assy MU		1	1				KB00C887G01		
324	R63 014 162	G	Frame assy MU	BS		1	1			KB00C887G07		
325	R63 016 111	G	Frame assy MB		1	1				KB00L774G01		
326	R63 015 162	G	Frame assy MB	BS		1	1			KB00L774G07		
327	R61 050 162	G	Frame MR	XL	1	1				KB02J307H01		
328	R61 051 162	G	Frame MR	XL BS		1	1			KB02J307G01		
329	R61 004 118	G	Fan guard		2	2	2	2		KB25A241H03		
330	R11 003 077	G	Piping cover		1	1				KB02C040G06		
331	R11 004 077	G	Piping cover	BS		1	1			KB02C040G07		
332	R61 050 651	G	Panel FU		2	2				KB02B379H02		
333	R63 4H8 651	G	Panel FU	BS		2	2			KB02B379G04		
334	R61 157 651	G	Panel FBL	XL	1	1				KB02J308H02		
335	R61 158 651	G	Panel FBL	XL BS		1	1			KB02J308G04		
336	R63 159 651	G	Panel FBR	XL	1	1				KB02J309H03		
337	R61 160 651	G	Panel FBR	XL BS		1	1			KB02J309G04		
338	R63 004 611	G	Fin guard B		2	2	2	2		KB07T208G01		
339	R61 007 611	G	Fin guard LR		2	2	2	2		KB07C043G03		
340	R63 4H6 140	G	Base fan		4	4				KB02D050H01		
341	R63 4H7 140	G	Base fan	BS		4	4			KB02D050G03		
342	R61 128 220	G	Motor	EEOK-IOTV 920W	2	2	2	2		P780194X01		
343	R63 007 087	G	H Screw	5 x 10 KNURLED (30pcs)	5	5	5	5		KB00H418G14		
344	R63 4H6 300	G	Fan		2	2	2	2		KB25A009H03		
345	R63 4H6 122	G	Box nut	M12 CH	2	2	2	2		P552000X01		

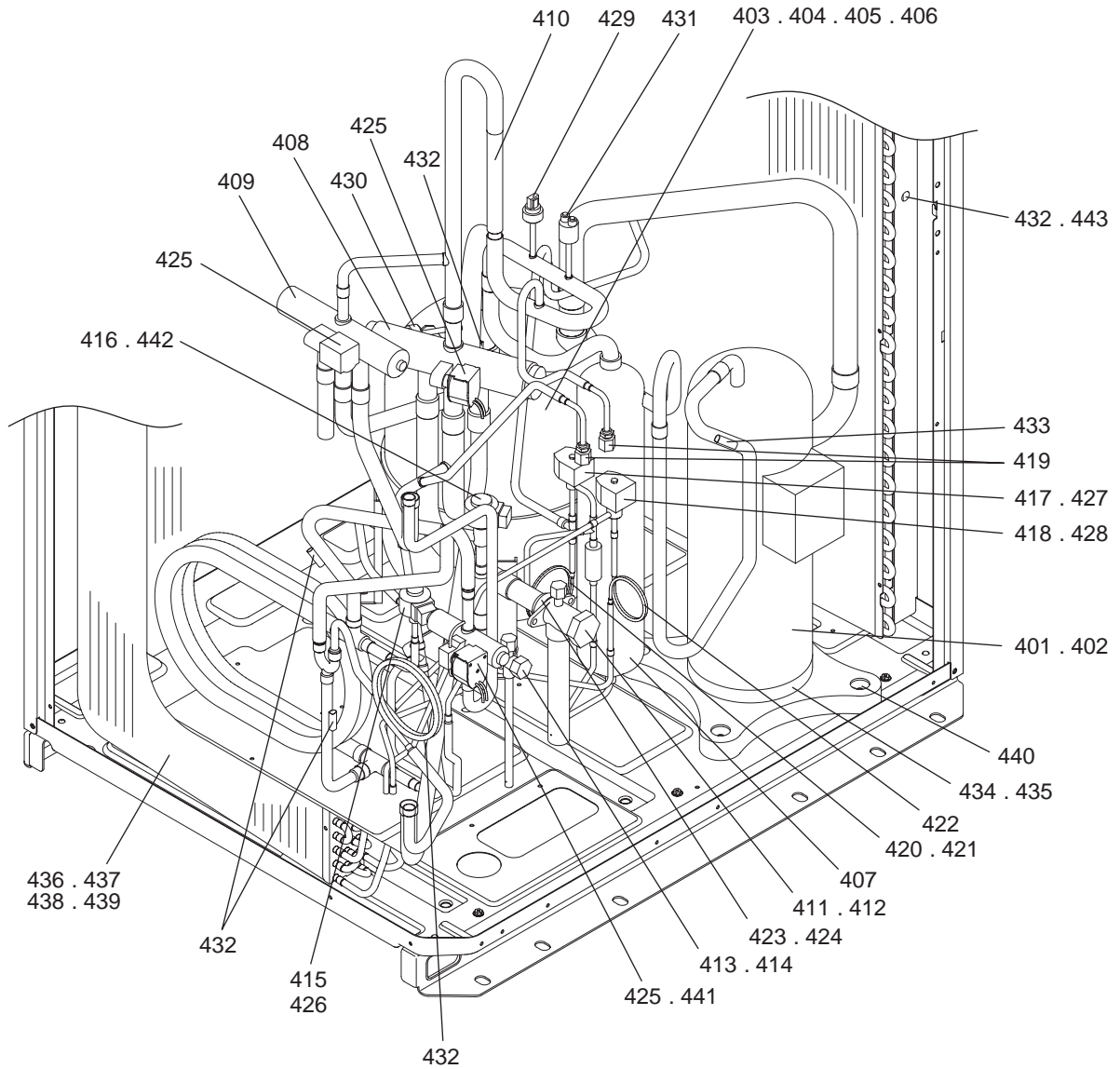

PUHY-P200,P250,P300YJM-A(-BS)
 PUHY-EP200YJM-A(-BS)

FUNCTIONAL PARTS (1)

No.	Part No.	G : RoHS Apply Only W : RoHS Apply by Running Change		Spec.	PUHY-P200YJM-A	PUHY-P200YJM-A-BS	PUHY-P250YJM-A	PUHY-P250YJM-A-BS	PUHY-P300YJM-A	PUHY-P300YJM-A-BS	Dwg. No.	Notes for the models	Revision info.
		Part Name											
401	R69 068 478	G	Scroll compressor	ENB52FC-YE	1	1	1	1			EP10107B08		
402	R69 070 478	G	Scroll compressor	HNB78FC-YE					1	1	EP10109B08		
403	R61 073 484	G	Accumulator assy		1		1				KB54B477G13		
404	R61 074 484	G	Accumulator assy	BS		1		1			KB54B477G14		
405	R61 075 484	G	Accumulator assy						1		KB54B478G13		
406	R61 076 484	G	Accumulator assy	BS						1	KB54B478G14		
407	R61 016 487	G	Oil separator assy		1	1	1	1	1	1	KB00G667G02		
408	R63 Y05 154	G	Four way valve	STF-07	1	1	1	1	1	1	P633119X01	<21S4a>	
409	R63 R55 154	G	Four way valve	STF04	1	1	1	1	1	1	P633118X01	<21S4b>	
410	R63 R43 418	G	Check valve	BCV-1005	1	1	1	1	1	1	P639165X01	<CV1>	
411	R61 001 540	G	Valve	VSAMH7SSCM-A	1	1					P636342X01	<BV1>	
412	R61 002 540	G	Valve	VSAMH8SSCM-A			1	1	1	1	P636343X01	<BV1>	
413	R61 003 540	G	Valve	VSAMH3SSCM-LA1	1	1	1	1			P636346X01	<BV2>	
414	R61 004 540	G	Valve	VSAMH4SSCM-LA1					1	1	P636345X01	<BV2>	
415	R63 4H6 401	G	Linear expansion valve	CAM35-S	1	1	1	1	1	1	P632444X01	<LEV1>	
416	R61 036 401	G	Linear expansion valve	PAM BBO20TON	1	1	1	1	1	1	P632504X01	<LEV2>	
417	R63 P90 232	G	Solenoid valve	VPV-152D	1	1	1	1	1	1	P631277X01	<SV1a>	
418	R63 Y07 232	G	Solenoid valve	ATS-A	1	1	1	1	1	1	P631291X01	<SV9>	
419	R63 R34 413	G	Check joint L	R410A	2	2	2	2	2	2	P666004X02	<(HP)CJ1,(LP)CJ2>	
420	R63 002 425	G	Capillary tube assy		1	1	1	1			KB49F229G01	<CP1>	
421	R63 R34 425	G	Capillary tube assy						1	1	W905625G02	<CP1>	
422	R61 003 425	G	Capillary tube assy		1	1	1	1	1	1	KB49F761G01	<CP2>	
423	R63 4H6 454	G	Strainer	19.05D	1	1					KD48G400G01	<ST1>	
424	R61 008 454	G	Strainer	25.4D			1	1	1	1	KB48K250G01	<ST1>	
425	R63 Y16 243	G	Solenoid coil	STF DV	3	3	3	3	3	3	P472024X01	<21S4a,21S4b,SV5b>	
426	R63 011 401	G	Linear expansion valve coil	CAM L1800 WHITE	1	1	1	1	1	1	P472059X02	<LEV1>	
427	R61 006 243	G	Solenoid coil	VPV Y	1	1	1	1	1	1	P472046X01	<SV1a>	
428	R63 Y18 243	G	Solenoid coil		1	1	1	1	1	1	P472012X01	<SV9>	
429	R61 006 288	G	Pressure sensor	HP D173	1	1	1	1	1	1	KB00H904G09	<63HS1>	
430	R61 007 288	G	Pressure sensor	LP D173	1	1	1	1	1	1	KB00H904G10	<63LS>	
431	R63 Y11 208	G	Pressure switch	ACB1UB28W	1	1	1	1	1	1	P426320X01	<63HS1>	
432	R61 060 200	G	Thermistor		5	5	5	5	5	5	P418065X01	<TH2,TH3,TH5-TH7>	
433	R63 911 202	G	Thermistor		1	1	1	1	1	1	P425416X02	<TH4>	
434	R61 003 237	G	Belt heater	240V 35W	1	1	1	1			P497067X01	<CH11>	
435	R63 Y07 237	G	Belt heater	240V 45W					1	1	P493781X02	<CH11>	
436	R61 452 480	G	Heat exchanger	2L	1						KB01G561G04		
437	R61 453 480	G	Heat exchanger	2L BS		1					KB01G561G05		
438	R61 456 480	G	Heat exchanger	2.5L			1		1		KD01G192G01		
439	R61 457 480	G	Heat exchanger	2.5L BS				1		1	KD01G192G02		
440	R63 852 860	G	Rubber mount	For compressor	4	4	4	4	4	4	W897574H01		
441	R61 004 235	G	Two way valve	MHV-1104	1	1	1	1	1	1	P637048X01	<SV5b>	
442	R61 022 243	G	Linear expansion valve coil	PAM	1	1	1	1	1	1	P472061X02	<LEV2>	
443	R61 001 310	G	Sensor holder		1	1	1	1	1	1	KB25B471H03		

PUHY-P200,P250,P300YJM-A(-BS)
 PUHY-EP200YJM-A(-BS)

FUNCTIONAL PARTS (1)

No.	Part No.	G : RoHS Apply Only W : RoHS Apply by Running Change		Spec.	PUHY-EP200YJM-A	PUHY-EP200YJM-A-BS					Dwg. No.	Notes for the models	Revision info.
			Part Name										
401	R69 068 478	G	Scroll compressor	ENB52FC-YE	1	1					EP10107B08		
402	R69 070 478	G	Scroll compressor	HNB78FC-YE							EP10109B08		
403	R61 073 484	G	Accumulator assy		1						KB54B477G13		
404	R61 074 484	G	Accumulator assy	BS		1					KB54B477G14		
405	R61 075 484	G	Accumulator assy								KB54B478G13		
406	R61 076 484	G	Accumulator assy	BS							KB54B478G14		
407	R61 016 487	G	Oil separator assy		1	1					KB00G667G02		
408	R63 Y05 154	G	Four way valve	STF-07	1	1					P633119X01	<21S4a>	
409	R63 R55 154	G	Four way valve	STF04	1	1					P633118X01	<21S4b>	
410	R63 R43 418	G	Check valve	BCV-1005	1	1					P639165X01	<CV1>	
411	R61 001 540	G	Valve	VSAMH7SSCM-A							P636342X01	<BV1>	
412	R61 002 540	G	Valve	VSAMH8SSCM-A	1	1					P636343X01	<BV1>	
413	R61 003 540	G	Valve	VSAMH3SSCM-LA1	1	1					P636346X01	<BV2>	
414	R61 004 540	G	Valve	VSAMH4SSCM-LA1							P636345X01	<BV2>	
415	R63 4H6 401	G	Linear expansion valve	CAM35-S	1	1					P632444X01	<LEV1>	
416	R61 036 401	G	Linear expansion valve	PAM BBO20TON	1	1					P632504X01	<LEV2>	
417	R63 P90 232	G	Solenoid valve	VPV-152D	1	1					P631277X01	<SV1a>	
418	R63 Y07 232	G	Solenoid valve	ATS-A	1	1					P631291X01	<SV9>	
419	R63 R34 413	G	Check joint L	R410A	2	2					P666004X02	<(HP)CJ1,(LP)CJ2>	
420	R63 002 425	G	Capillary tube assy		1	1					KB49F229G01	<CP1>	
421	R63 R34 425	G	Capillary tube assy								W905625G02	<CP1>	
422	R61 003 425	G	Capillary tube assy		1	1					KB49F761G01	<CP2>	
423	R63 4H6 454	G	Strainer	19.05D							KD48G400G01	<ST1>	
424	R61 008 454	G	Strainer	25.4D	1	1					KB48K250G01	<ST1>	
425	R63 Y16 243	G	Solenoid coil	STF DV	3	3					P472024X01	<21S4a,21S4b,SV5b>	
426	R63 011 401	G	Linear expansion valve coil	CAM L1800 WHITE	1	1					P472059X02	<LEV1>	
427	R61 006 243	G	Solenoid coil	VPV Y	1	1					P472046X01	<SV1a>	
428	R63 Y18 243	G	Solenoid coil		1	1					P472012X01	<SV9>	
429	R61 006 288	G	Pressure sensor	HP D173	1	1					KB00H904G09	<63HS1>	
430	R61 007 288	G	Pressure sensor	LP D173	1	1					KB00H904G10	<63LS>	
431	R63 Y11 208	G	Pressure switch	ACB1UB28W	1	1					P426320X01	<63HS1>	
432	R61 060 200	G	Thermistor		5	5					P418065X01	<TH2,TH3,TH5-TH7>	
433	R63 911 202	G	Thermistor		1	1					P425416X02	<TH4>	
434	R61 003 237	G	Belt heater	240V 35W	1	1					P497067X01	<CH11>	
435	R63 Y07 237	G	Belt heater	240V 45W							P493781X02	<CH11>	
436	R61 452 480	G	Heat exchanger	2L							KB01G561G04		
437	R61 453 480	G	Heat exchanger	2L BS							KB01G561G05		
438	R61 456 480	G	Heat exchanger	2.5L	1						KD01G192G01		
439	R61 457 480	G	Heat exchanger	2.5L BS		1					KD01G192G02		
440	R63 852 860	G	Rubber mount	For compressor	4	4					W897574H01		
441	R61 004 235	G	Two way valve	MHV-1104	1	1					P637048X01	<SV5b>	
442	R61 022 243	G	Linear expansion valve coil	PAM	1	1					P472061X02	<LEV2>	
443	R61 001 310	G	Sensor holder		1	1					KB25B471H03		

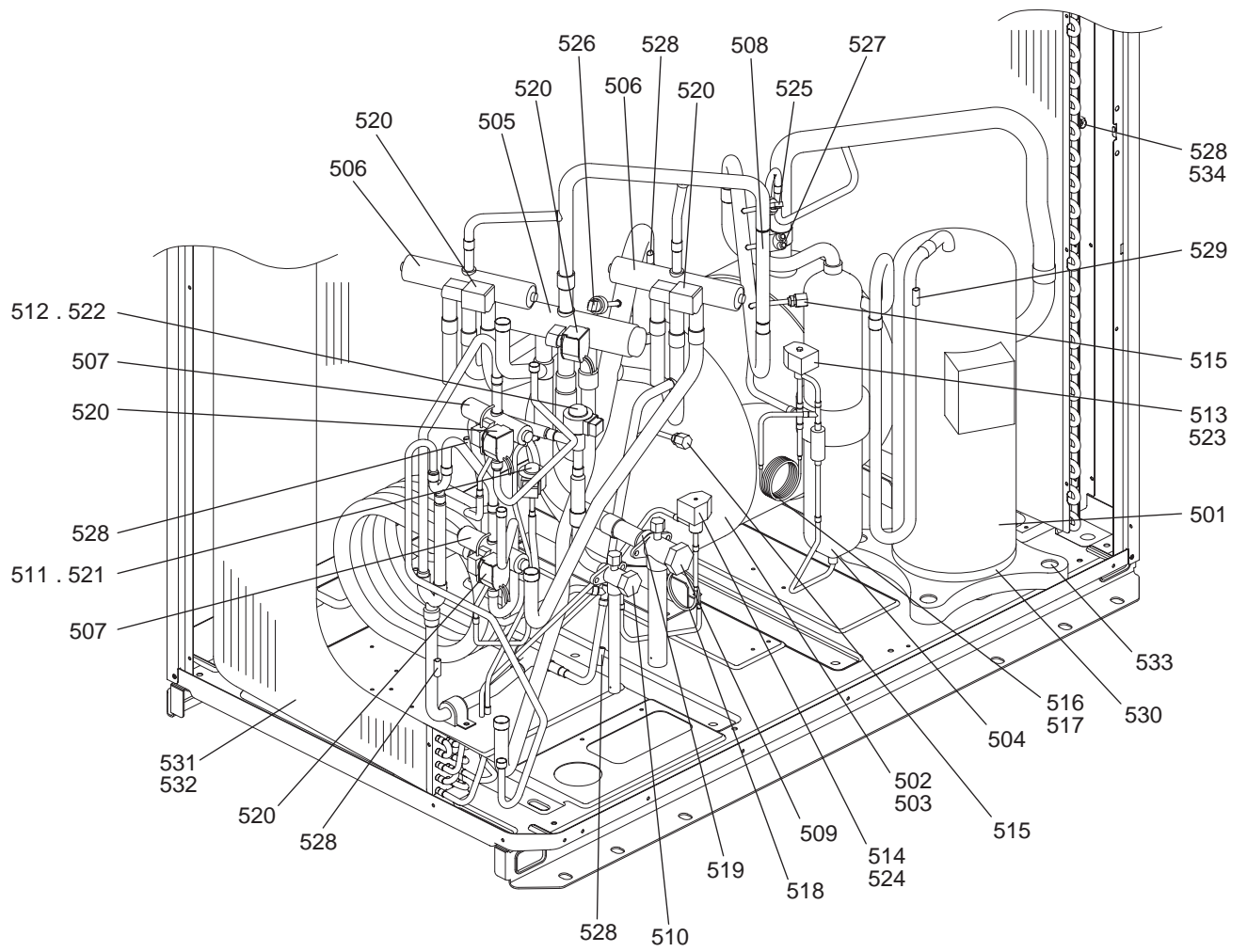

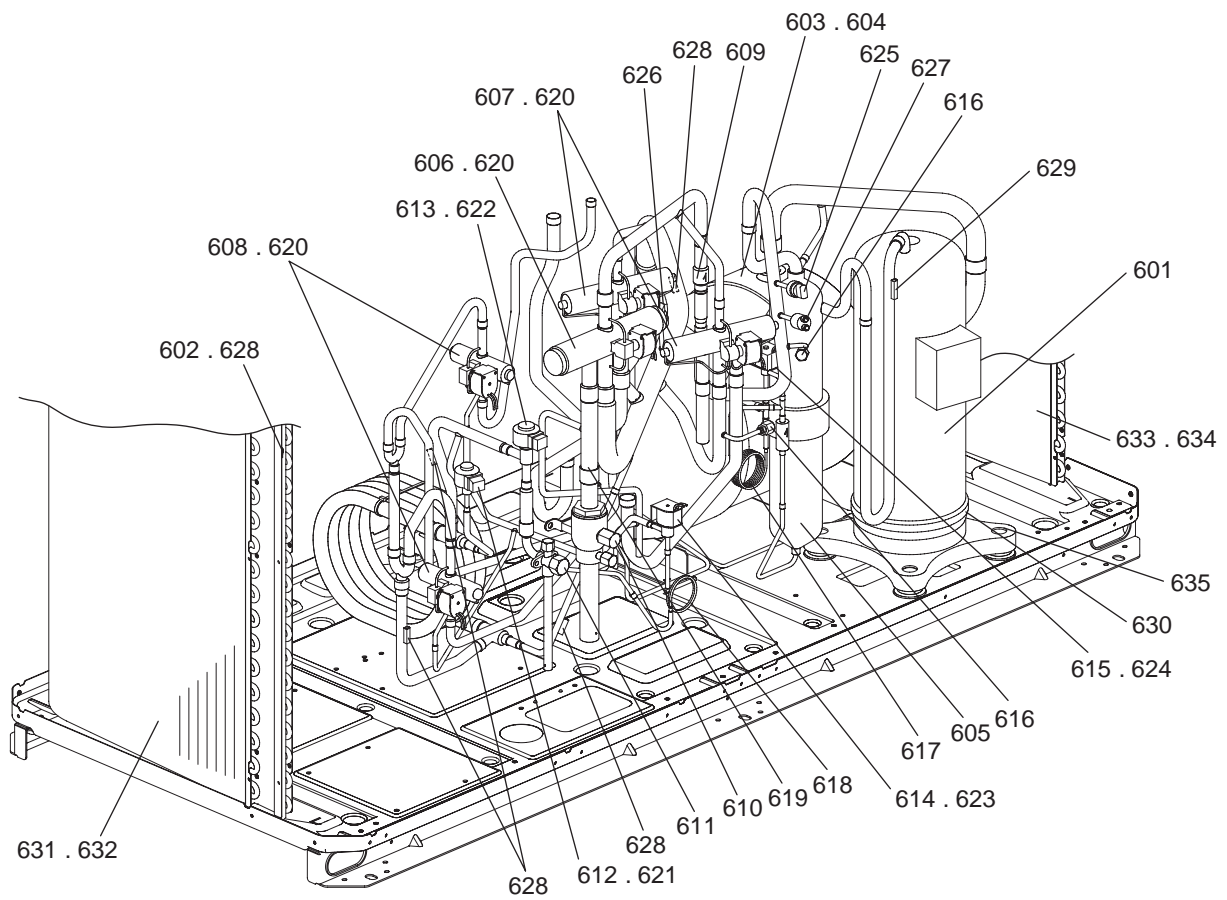

PUHY-P200,P250,P300YJM-A(-BS)
PUHY-P350,P400,P450YJM-A(-BS)
PUHY-EP200,EP250,EP300YJM-A(-BS)

CONTROL BOX PARTS

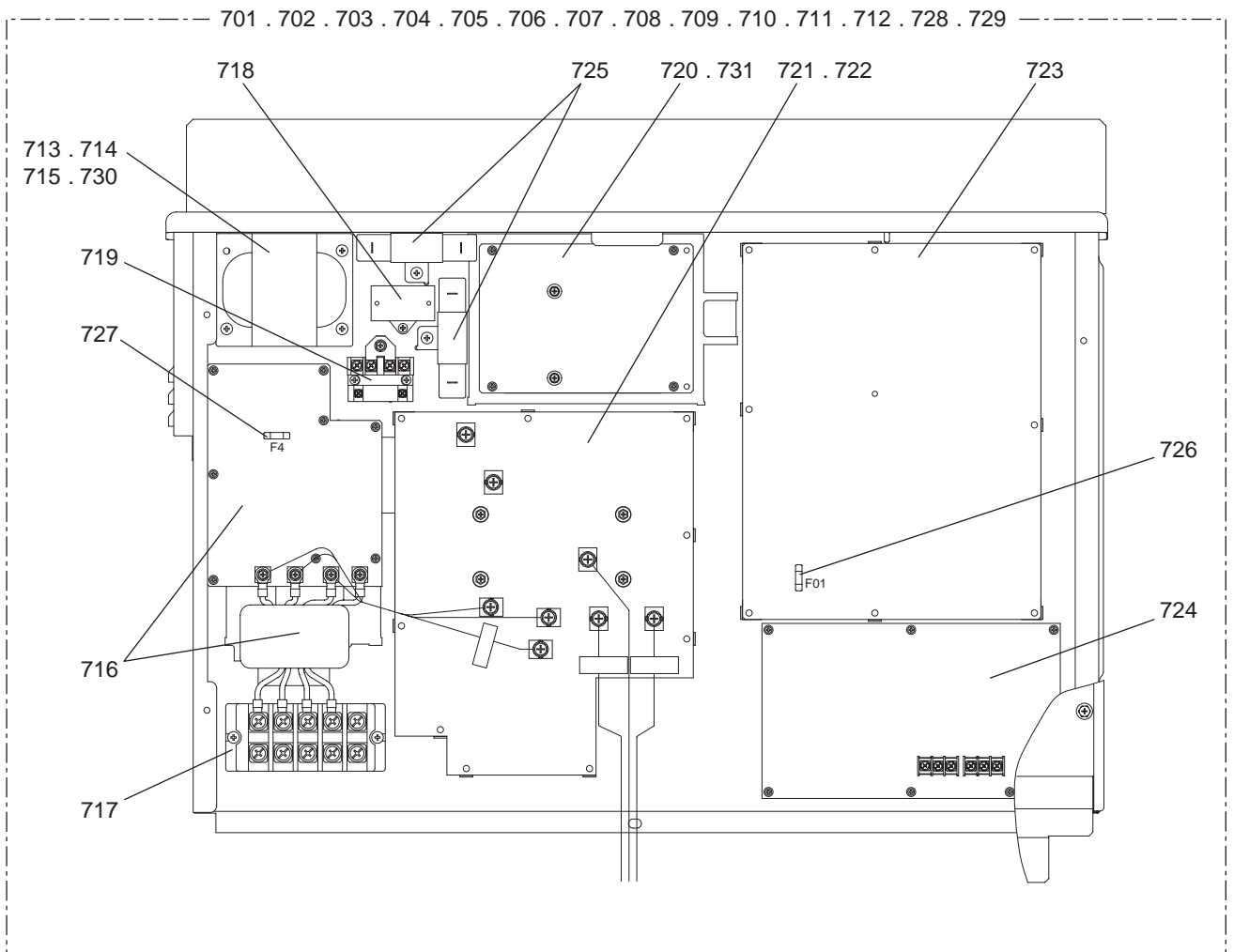

PUHY-P200,P250,P300YJM-A(-BS)
 PUHY-P350,P400,P450YJM-A(-BS)
 PUHY-EP200,EP250,EP300YJM-A(-BS)

CONTROL BOX PARTS

No.	Part No.	G : RoHS Apply Only W : RoHS Apply by Running Change	Part Name	Spec.	PUHY-P200YJM-A	PUHY-P200YJM-A-BS	PUHY-P250YJM-A	PUHY-P250YJM-A-BS	PUHY-P300YJM-A	PUHY-P300YJM-A-BS	Dwg. No.	Notes for the models	Revision info.
702	R61 334 305	G	Control box	P250 BS		1	1				KE80C390G20		
703	R61 337 305	G	Control box	P300YJM					1		KE80C390G23		
704	R61 338 305	G	Control box	P300 BS						1	KE80C390G24		
705	R61 341 305	G	Control box	P350YJM							KE80C390G27		
706	R61 342 305	G	Control box	P350 BS							KE80C390G28		
707	R61 343 305	G	Control box	P450YJM							KE80C390G29		
708	R61 344 305	G	Control box	P450 BS							KE80C390G30		
709	R61 335 305	G	Control box	EP200YJM							KE80C390G21		
710	R61 336 305	G	Control box	EP200 BS							KE80C390G22		
711	R61 345 305	G	Control box	EP300YJM							KE80C390G31		
712	R61 346 305	G	Control box	EP300 BS							KE80C390G32		
713	R61 027 259	G	Reactor		1	1	1	1			P715476X01	<DCL>	
714	R61 028 259	G	Reactor						1	1	P715475X01	<DCL>	
715	R61 012 259	G	Reactor								P715441X02	<DCL>	
716	R61 015 293	G	Noise filter		1	1	1	1	1	1	KE80C155G05	<Noise Filter,L>	
717	R61 007 246	G	Terminal block		1	1	1	1	1	1	S436005H12	<TB1>	
718	R61 001 255	G	Capacitor assy		1	1	1	1	1	1	KE00D263G01	<C100>	
719	R61 003 216	G	Relay		1	1	1	1	1	1	P421295X01	<72C>	
720	R61 037 280	G	FAN board		1	1	1	1	1	1	W652171G07		
721	R61 154 280	G	INV board		1	1	1	1			KE80C154G09		
722	R61 155 280	G	INV board						1	1	KE80C154G10		
723	R61 058 281	G	Control board		1	1	1	1	1	1	KE80C153G67		
724	R61 012 281	G	M-NET board		1	1	1	1	1	1	KE80C055G03		
725	R61 001 234	G	Resistor		2	2	2	2	2	2	P411151X01	<R1,R5>	
726	R61 005 239	G	Fuse	3.15A AC250V T	1	1	1	1	1	1	S423001H39		
727	R61 006 239	G	Fuse	6.3A AC250V T	1	1	1	1	1	1	S423001H42		
728	R61 339 305	G	Control box	EP250YJM							KE80C390G25		
729	R61 340 305	G	Control box	EP250 BS							KE80C390G26		
730	R61 017 259	G	Reactor								P715458X01	<DCL>	
731	R61 084 281	G	FAN board								W652171G16		Chg.

