

SERVICE PARTS LIST FOR MITSUBISHI ELECTRIC PACKAGED AIR-CONDITIONERS

Series : PQHY-P•YLM-A1
PQHY-P•YLM-A2

Apr. 2017
BWE017030

| INDEX |
|---------------------------------|
| PQHY-P200YLM-A1 PQHY-P200YLM-A2 |
| PQHY-P250YLM-A1 PQHY-P250YLM-A2 |
| PQHY-P300YLM-A1 PQHY-P300YLM-A2 |
| PQHY-P350YLM-A1 PQHY-P350YLM-A2 |
| PQHY-P400YLM-A1 PQHY-P400YLM-A2 |
| PQHY-P450YLM-A1 PQHY-P450YLM-A2 |
| PQHY-P500YLM-A1 PQHY-P500YLM-A2 |
| PQHY-P550YLM-A1 PQHY-P550YLM-A2 |
| PQHY-P600YLM-A1 PQHY-P600YLM-A2 |

The Package name list

PQHY-P400YSLM-A1 [PQHY-P200YLM-A1+PQHY-P200YLM-A1]

PQHY-P450YSLM-A1 [PQHY-P200YLM-A1+PQHY-P250YLM-A1]

PQHY-P500YSLM-A1 [PQHY-P250YLM-A1+PQHY-P250YLM-A1]

PQHY-P550YSLM-A1 [PQHY-P250YLM-A1+PQHY-P300YLM-A1]

PQHY-P600YSLM-A1 [PQHY-P300YLM-A1+PQHY-P300YLM-A1]

PQHY-P700YSLM-A1 [PQHY-P350YLM-A1+PQHY-P350YLM-A1]

PQHY-P750YSLM-A1 [PQHY-P350YLM-A1+PQHY-P400YLM-A1]

PQHY-P800YSLM-A1 [PQHY-P400YLM-A1+PQHY-P400YLM-A1]

PQHY-P850YSLM-A1 [PQHY-P400YLM-A1+PQHY-P450YLM-A1]

PQHY-P900YSLM-A1 [PQHY-P450YLM-A1+PQHY-P450YLM-A1]

PQHY-P400YSLM-A2 [PQHY-P200YLM-A2+PQHY-P200YLM-A2]

PQHY-P450YSLM-A2 [PQHY-P200YLM-A2+PQHY-P250YLM-A2]

PQHY-P500YSLM-A2 [PQHY-P250YLM-A2+PQHY-P250YLM-A2]

PQHY-P550YSLM-A2 [PQHY-P250YLM-A2+PQHY-P300YLM-A2]

PQHY-P600YSLM-A2 [PQHY-P300YLM-A2+PQHY-P300YLM-A2]

PQHY-P700YSLM-A2 [PQHY-P350YLM-A2+PQHY-P350YLM-A2]

PQHY-P750YSLM-A2 [PQHY-P350YLM-A2+PQHY-P400YLM-A2]

PQHY-P800YSLM-A2 [PQHY-P400YLM-A2+PQHY-P400YLM-A2]

PQHY-P850YSLM-A2 [PQHY-P400YLM-A2+PQHY-P450YLM-A2]

PQHY-P900YSLM-A2 [PQHY-P450YLM-A2+PQHY-P450YLM-A2]

PQHY-P200YLM-A1,A2
PQHY-P250YLM-A1,A2
PQHY-P300YLM-A1,A2

EXTERNAL PARTS (1)

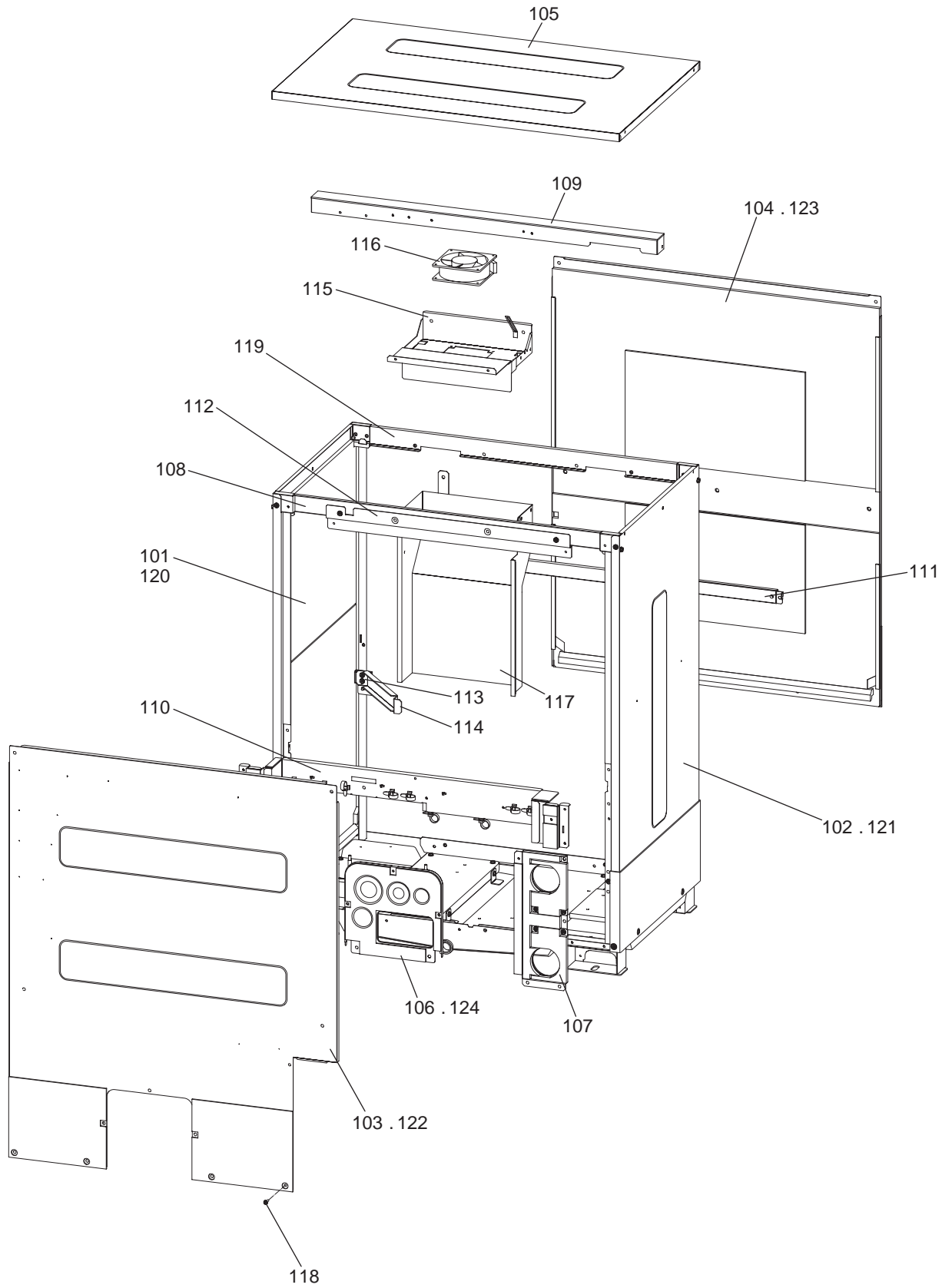

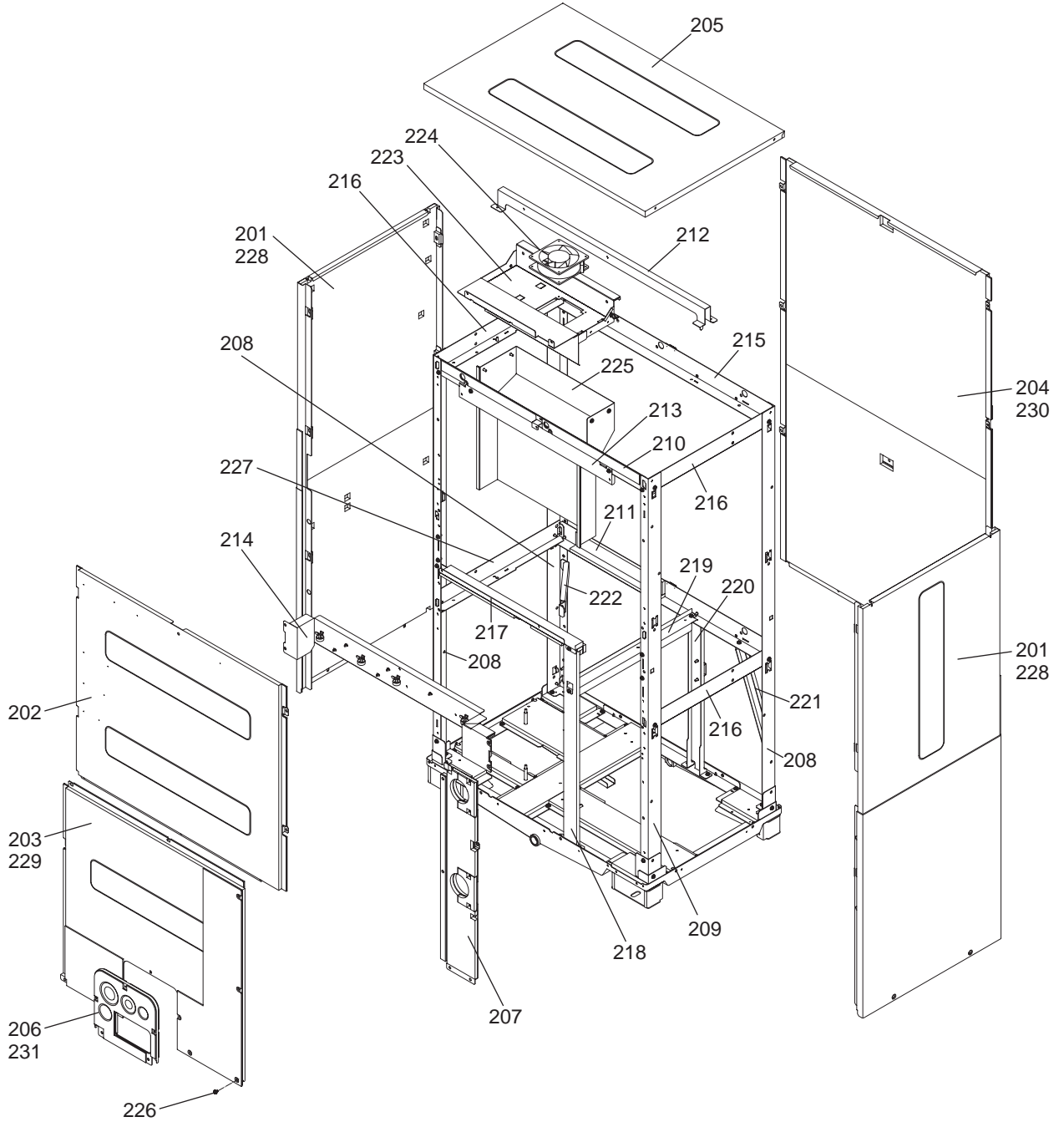

PQHY-P200YLM-A1,A2
PQHY-P250YLM-A1,A2
PQHY-P300YLM-A1,A2

FUNCTIONAL PARTS (1)

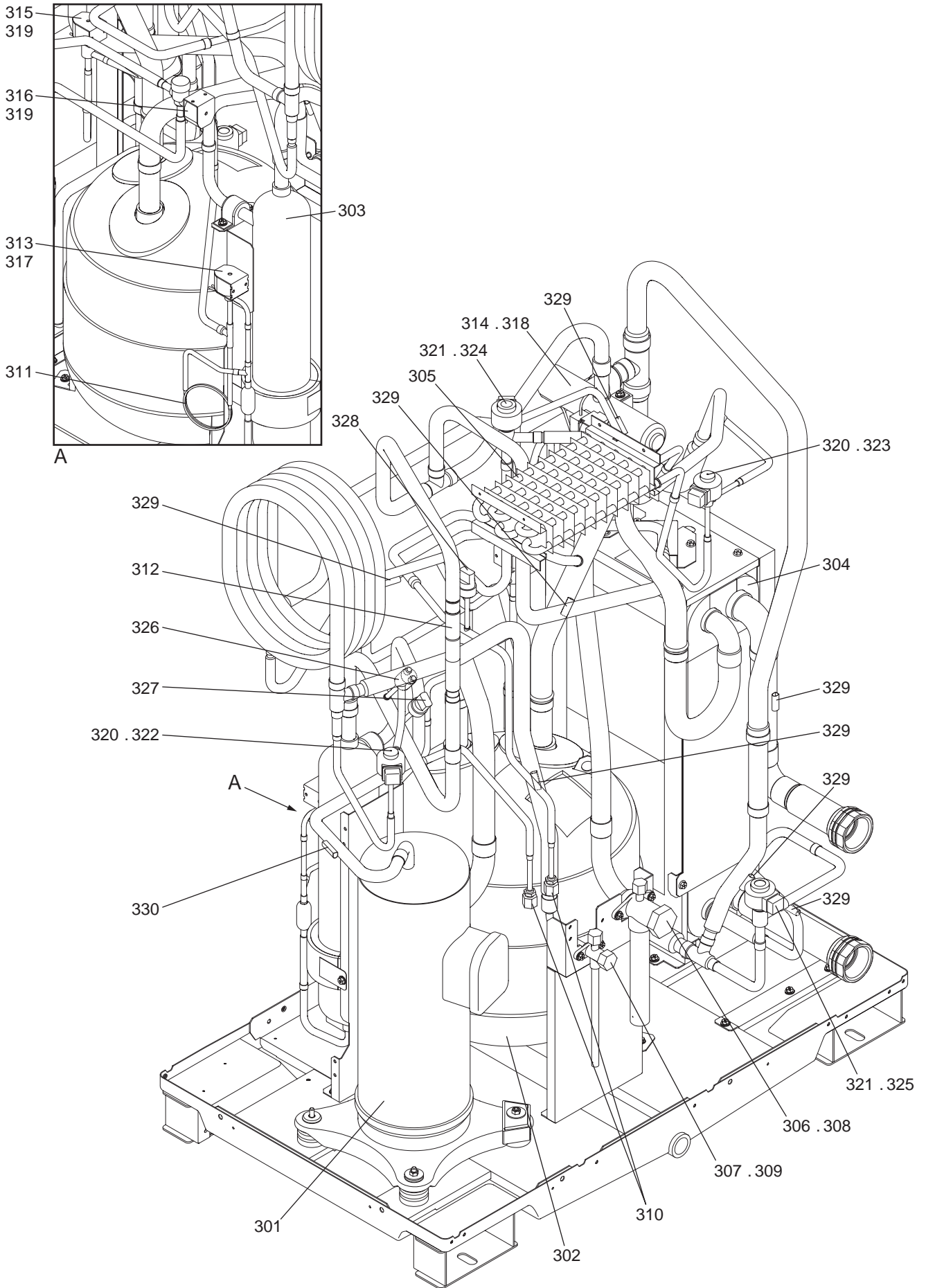

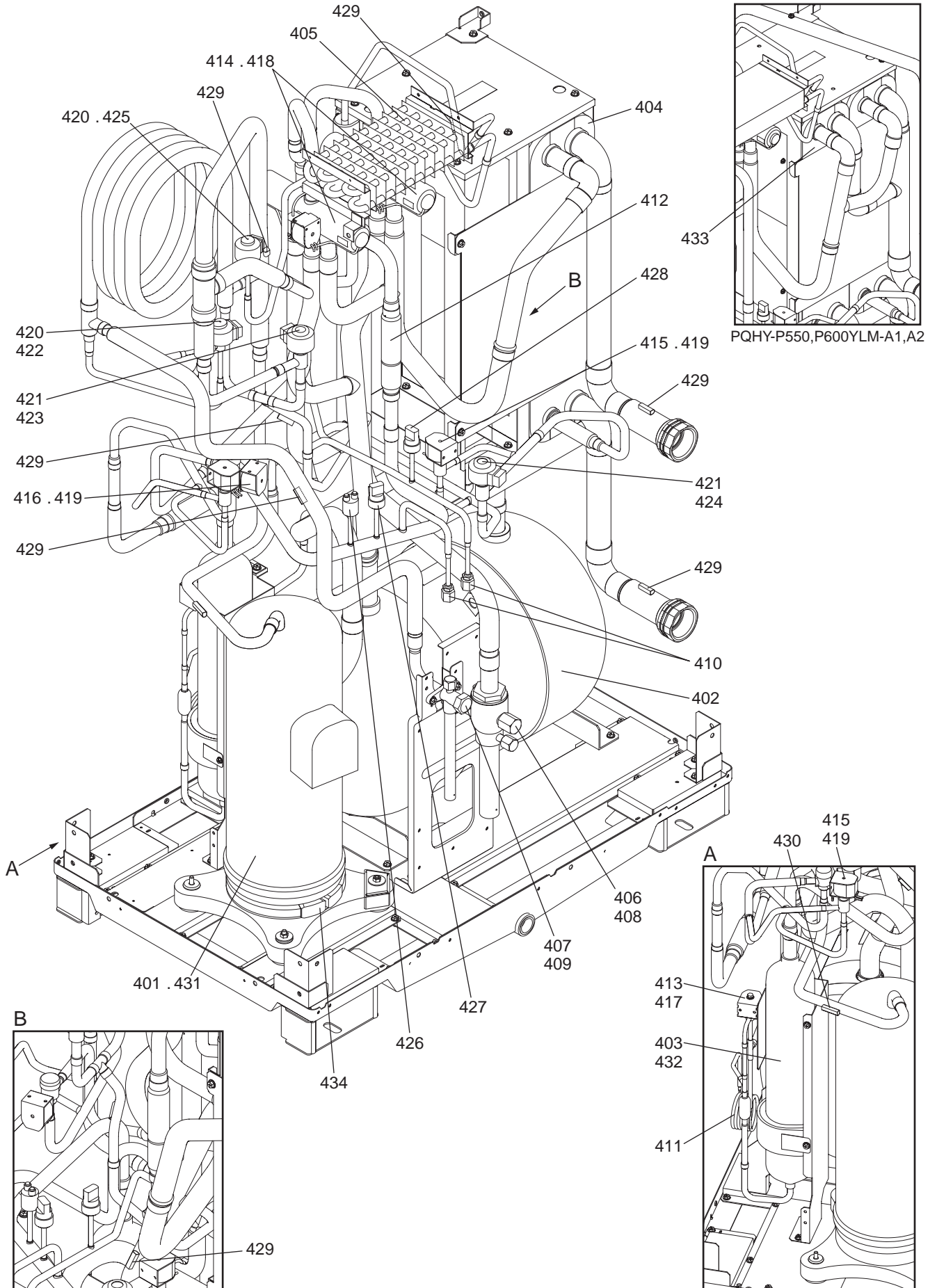

PQHY-P200,P250,P300YLM-A1,A2
PQHY-P350,P400,P450YLM-A1,A2
PQHY-P500,P550,P600YLM-A1,A2

CONTROL BOX PARTS

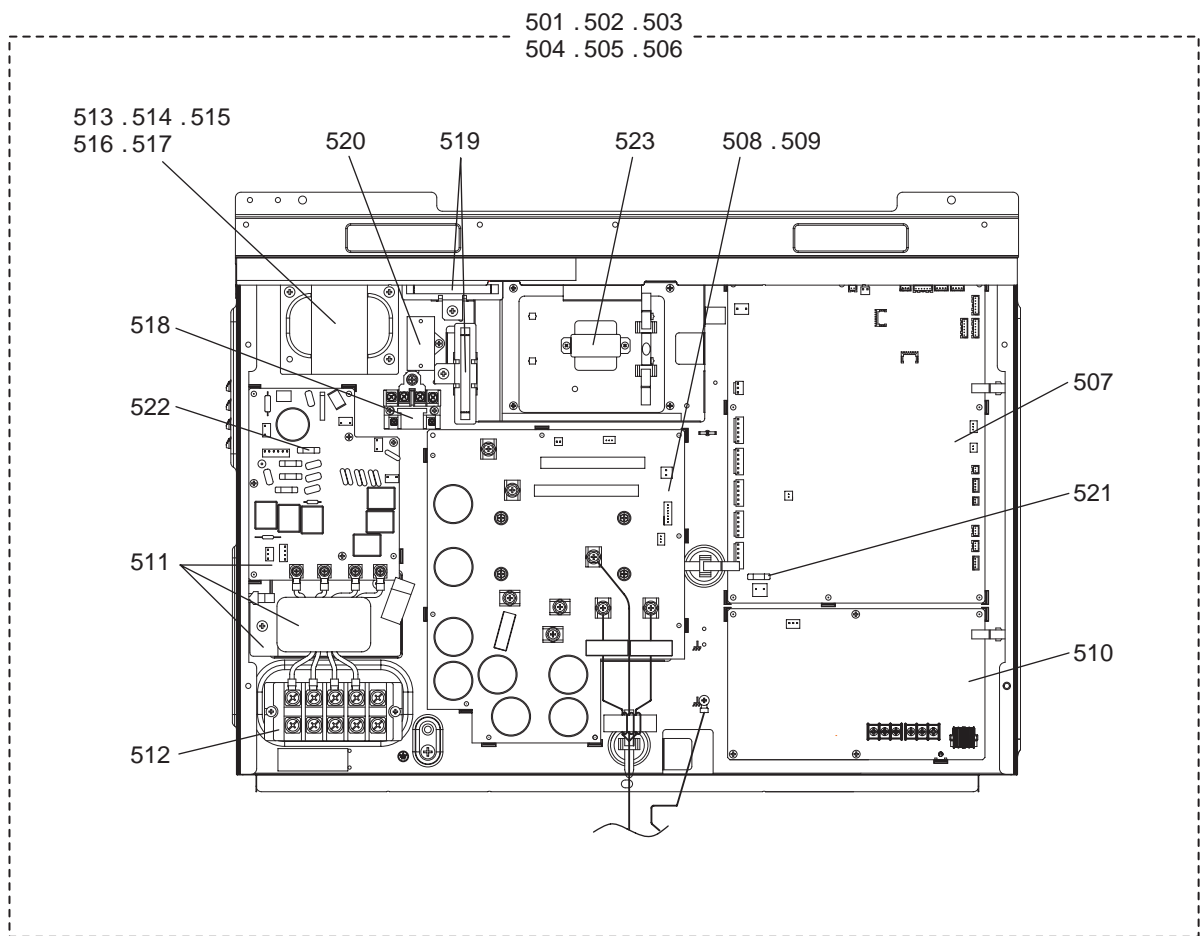

PQHY-P200,P250,P300YLM-A1,A2
PQHY-P350,P400,P450YLM-A1,A2
PQHY-P500,P550,P600YLM-A1,A2

I/O BOX PARTS

