

# Air-Conditioners For Building Application

## INDOOR UNIT

# PMFY-P·VBM-E

For use with the R410A, R407C & R22    Για χρήση με τα R410A, R407C και R22  
Bei Verwendung von R410A, R407C & R22    Para utilização com o R410A, R407C e o R22  
A utiliser avec le R410A, R407C et le R22    R410A, R407C ve R22 ile beraber kullanmak için  
Bij gebruik van R410A, R407C & R22    Для использования с моделями R410A, R407C и R22  
Para utilizar con el R410A, R407C y el R22  
Uso del refrigerante R410A, R407C e R22

### INSTALLATION MANUAL

For safe and correct use, read this manual and the outdoor unit installation manual thoroughly before installing the air-conditioner unit.

**FOR INSTALLER**

### INSTALLATIONSHANDBUCH

Aus Sicherheitsgründen und zur richtigen Anwendung vor Installation der Klimaanlage die vorliegende Bedienungsanleitung und das Installationshandbuch gründlich durchlesen.

**FÜR INSTALLATEURE**

### MANUEL D'INSTALLATION

Avant d'installer le climatiseur, lire attentivement ce manuel, ainsi que le manuel d'installation de l'appareil extérieur pour une utilisation sûre et correcte.

**POUR L'INSTALLATEUR**

### INSTALLATIEHANDLEIDING

Lees deze handleiding en de installatiehandleiding van het buitenapparaat zorgvuldig door voordat u met het installeren van de airconditioner begint.

**VOOR DE INSTALLATEUR**

### MANUAL DE INSTALACIÓN

Para un uso seguro y correcto, lea detalladamente este manual de instalación antes de montar la unidad de aire acondicionado.

**PARA EL INSTALADOR**

### MANUALE DI INSTALLAZIONE

Per un uso sicuro e corretto, prima di installare il condizionatore d'aria leggere attentamente il presente manuale ed il manuale d'installazione dell'unità esterna.

**PER L'INSTALLATORE**

### ΕΓΧΕΙΡΙΔΙΟ ΟΔΗΓΙΩΝ ΕΓΚΑΤΑΣΤΑΣΗΣ

Για σωστή και ασφαλή χρήση, διαβάστε προσεκτικά αυτό το εγχειρίδιο, καθώς και το εγχειρίδιο εγκατάστασης της εξωτερικής μονάδας, πριν από την εγκατάσταση της μονάδας κλιματιστικού.

**ΓΙΑ ΑΥΤΟΝ ΠΟΥ ΚΑΝΕΙ ΤΗΝ ΕΓΚΑΤΑΣΤΑΣΗ**

### MANUAL DE INSTALAÇÃO

Para uma utilização segura e correcta, leia atentamente este manual e o manual de instalação da unidade exterior antes de instalar o aparelho de ar condicionado.

**PARA O INSTALADOR**

### MONTAJ ELKİTABI

Emniyetli ve doğru kullanım için, klima cihazını monte etmeden önce bu kılavuzu ve dış ünite montaj kılavuzunu tamamiyla okuyun.

**MONTÖR İÇİN**

### РУКОВОДСТВО ПО УСТАНОВКЕ

Для обеспечения безопасной и надлежащей эксплуатации внимательно прочтите данное руководство и руководство по установке наружного прибора перед установкой кондиционера.

**ДЛЯ УСТАНОВИТЕЛЯ****English (GB)****Deutsch (D)****Français (F)****Nederlands (NL)****Español (E)****Italiano (I)****Ελληνικά (GR)****Português (P)****Türkçe (TR)****Русский (RU)**

# Contents

1. Safety precautions.....	2	4. Electrical work .....	6
2. Installing the indoor unit.....	2	5. Installing the grille.....	7
3. Refrigerant pipe and drain pipe .....	4	6. Test run.....	9

**Note:**  
The phrase "Wired remote controller" in this installation manual refers only to the PAR-21MAA.  
If you need any information for the other remote controller, please refer to either the installation manual or initial setting manual which are included in these boxes.

## 1. Safety precautions

- ▶ Before installing the unit, make sure you read all the "Safety precautions".
- ▶ Please report to your supply authority or obtain their consent before connecting this equipment to the power supply system.

**Warning:**  
Describes precautions that must be observed to prevent danger of injury or death to the user.

**Caution:**  
Describes precautions that must be observed to prevent damage to the unit.

After installation work has been completed, explain the "Safety Precautions," use, and maintenance of the unit to the customer according to the information in the Operation Manual and perform the test run to ensure normal operation. Both the Installation Manual and Operation Manual must be given to the user for keeping. These manuals must be passed on to subsequent users.

- Warning:**
- Ask the dealer or an authorized technician to install the air conditioner.
  - Install the unit at a place that can withstand its weight.
  - Use only specified cables for wiring. The wiring connections must be made securely with no tension applied on the terminal connections. Also, never splice the cables for wiring (unless otherwise indicated in this document). Failure to observe these instructions may result in overheating or a fire.
  - Use only accessories authorized by Mitsubishi Electric and ask the dealer or an authorized technician to install them.
  - Do not touch the heat exchanger fins.
  - Install the air conditioner according to this Installation Manual.
  - Have all electric work done by a licensed electrician according to local regulations.
  - If the air conditioner is installed in a small room, measures must be taken to prevent the refrigerant concentration from exceeding the safety limit even if the refrigerant should leak.

- Caution:**
- Do not use the existing refrigerant piping, when use R410A or R407C refrigerant.
  - Use ester oil, either oil or alkylbenzene (small amount) as the refrigerator oil to coat flares and flange connections, when use R410A or R407C refrigerant.
  - Do not use the air conditioner where food, pets, plants, precision instruments, or artwork are kept.
  - Do not use the air conditioner in special environments.
  - Ground the unit.

- ⊘ : Indicates an action that must be avoided.
- ⚠ : Indicates that important instructions must be followed.
- ⚡ : Indicates a part which must be grounded.
- ⚠ : Indicates that caution should be taken with rotating parts.
- ⚡ : Indicates that the main switch must be turned off before servicing.
- ⚡ : Beware of electric shock.
- ⚠ : Beware of hot surface.
- ⚡ ELV : At servicing, please shut down the power supply for both the Indoor and Outdoor Unit.

**Warning:**  
Carefully read the labels affixed to the main unit.

- The cut face punched parts may cause injury by cut, etc. The installers are requested to wear protective equipment such as gloves, etc.
- When installing or relocating, or servicing the air conditioner, use only the specified refrigerant (R410A) to charge the refrigerant lines. Do not mix it with any other refrigerant and do not allow air to remain in the lines. If air is mixed with the refrigerant, then it can be the cause of abnormal high pressure in the refrigerant line, and may result in an explosion and other hazards. The use of any refrigerant other than that specified for the system will cause mechanical failure or system malfunction or unit breakdown. In the worst case, this could lead to a serious impediment to securing product safety.

- Install an leak circuit breaker, as required.
- Use power line cables of sufficient current carrying capacity and rating.
- Use only a circuit breaker and fuse of the specified capacity.
- Do not touch the switches with wet fingers.
- Do not touch the refrigerant pipes during and immediately after operation.
- Do not operate the air conditioner with the panels and guards removed.
- Do not turn off the power immediately after stopping operation.

## 2. Installing the indoor unit

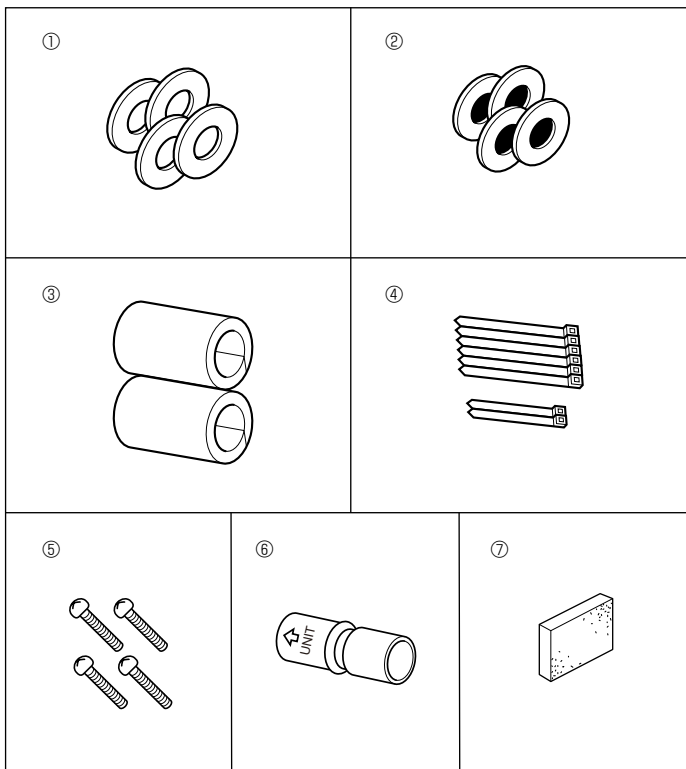

Fig. 2-1

### 2.1. Check the indoor unit accessories (Fig. 2-1)

The indoor unit should be supplied with the following spare parts and accessories (contained in the inside of the intake grille).

	Accessory name	Q'ty
①	Washer	4 pcs
②	Washer (with insulation)	4 pcs
③	Pipe cover	2 pcs
④	Band	large : 6 pcs , small : 2 pcs
⑤	Screw	4 pcs M5 x 0.8 x 30
⑥	Drain socket	1 pc Marked with "UNIT"
⑦	Insulation	1 pc

## 2. Installation location

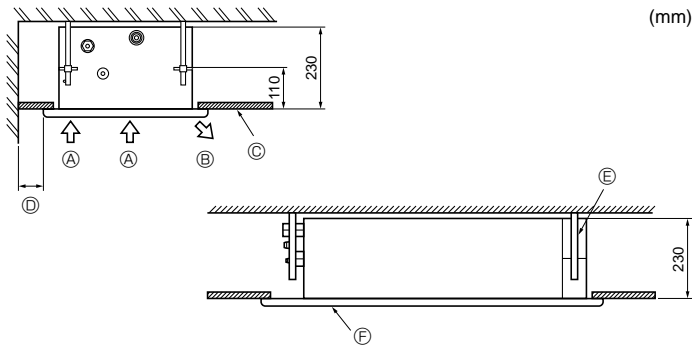

Fig. 2-2

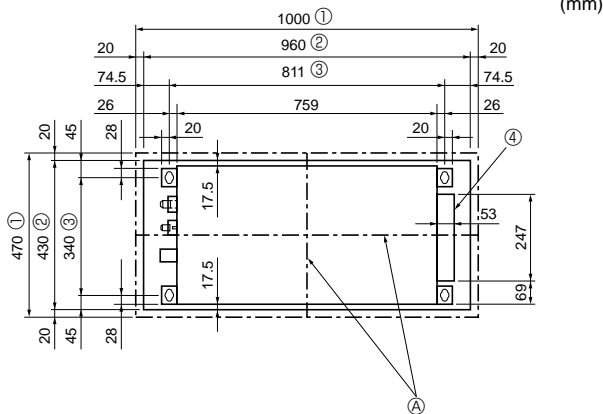

Fig. 2-3

### 2.2. Service space (Fig. 2-2)

The dimensions of ceiling opening can be regulated within the range shown in following diagram; so centre the main unit against the opening of ceiling, ensuring that the respective opposite sides on all sides of the clearance between them becomes identical.

- Ⓐ Air intake
- Ⓑ Air outlet
- Ⓒ Ceiling panel
- Ⓓ Min. 200 mm
- Ⓔ Suspension bolts W3/8 or M10
- Ⓕ Grille

### 2.3. Ceiling openings and suspension bolt installation locations (Fig. 2-3)

Make an opening in the ceiling 430 mm x 960 mm in size. This functions as a check window and will be needed later during servicing.

If the dimensions are not accurate, when the grille is installed there may be gaps between it and the indoor unit. This may result in dripping water or other problems.

When deciding on placement, consider carefully the space around the ceiling and make your measurements generous.

Ceiling types and building construction differ. Therefore you should consult with the builder and decorator.

- Ⓐ The centres of the ceiling opening and the indoor unit should be aligned.
- ① Outer side of grille
- ② Ceiling opening
- ③ Bolt pitch
- ④ Electric box

Using the installation template (top of the package) and the gauge (supplied as an accessory with the grille), make an opening in the ceiling so that the main unit can be installed as shown in the diagram. (The method for using the template and the gauge are shown.)

Use M10 (3/8") suspension bolts.

\*Suspension bolts are to be procured at the field.

After suspending the indoor unit, you will have to connect the pipes and wiring above the ceiling. Once the location has been fixed and the direction of the pipes has been determined, place the refrigerant and drainage pipes, the wiring for the remote controller, and the wiring that connects the indoor and outdoor units in their desired locations before suspending the indoor unit. This is especially important in cases where the ceiling is already in existence.

① Wooden structures (Fig. 2-4)

Use tie beams (single storied houses) or second floor beams (2 story houses) as reinforcing members.

Wooden beams for suspending air conditioners must be sturdy and their sides must be at least 6 cm long if the beams are separated by not more than 90 cm and their sides must be at least 9 cm long if the beams are separated by as much as 180 cm. The size of the suspension bolts should be  $\phi$  10 mm (3/8"). (The bolts do not come with the unit.)

Use channel, duct and other parts procured locally to suspend the indoor unit.

② Ferro-concrete structures (Fig. 2-5)

Secure the suspension bolts using the method shown, or use steel or wooden hangers, etc. to install the suspension bolts.

- Ⓓ Ceiling panel
- Ⓔ Rafters
- Ⓕ Beam
- Ⓖ Roof beam
- Ⓗ Use inserts rated at 100 - 150 kg each
- ① Suspension bolts M10 (3/8") (procure locally)
- Ⓙ Steel reinforcing rod
- Ⓚ C channel
- Ⓛ Channel suspension bracket (procure locally)
- Ⓜ M10 suspension bolt

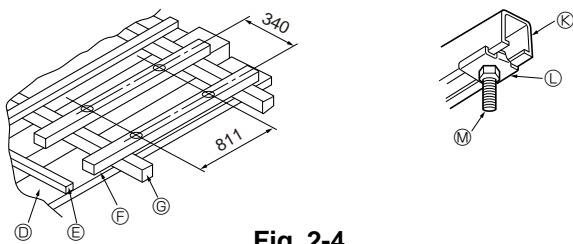

Fig. 2-4

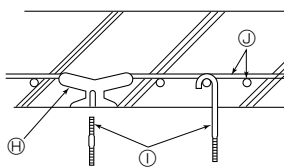

Fig. 2-5

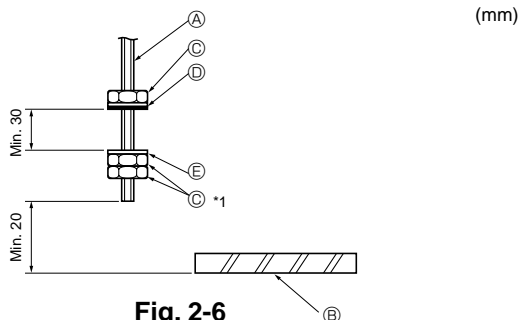

Fig. 2-6

### 2.4. Unit suspension procedures (Fig. 2-6)

Procure 3/8" bolts or M10 bolts locally.

Adjust the length of the bolt's protrusion from the ceiling surface beforehand.

\*1. When using an extra upper nut in suspending the unit, in some cases you may have to add it later.

- Ⓐ Suspension bolt
- Ⓑ Ceiling panel
- Ⓒ Nut
- Ⓓ Washer (with insulation) ②
- Ⓔ Washer (without insulation) ①

## 2. Installing the indoor unit

1. 2. 3.

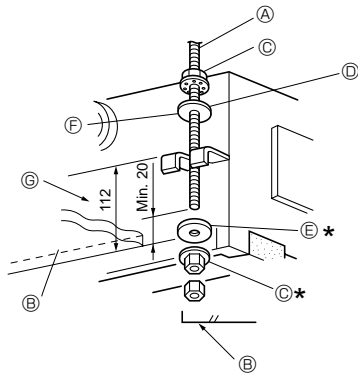

Fig. 2-7

4.

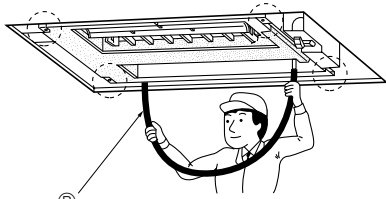

Fig. 2-8

5.

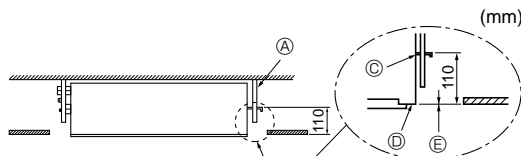

Fig. 2-9

(mm)

Check the pitch of the suspension bolt. (340 mm × 811 mm)

1. Thread washers ① ② (supplied) and their nuts (procured locally) onto the suspension bolt in advance. (Fig. 2-7)

\* Do this in the following order (from the top): nut, insulated washer ②, washer without insulation ①, 2 nuts.

\* Position insulated washer ② with the insulated surface pointing down, as in the figure.

2. Lift the unit into place, aligned properly with the suspension bolt. Pass the bracket between washers ① and ②, which are already in place, and secure it. Do the same in all four places.

\* Make sure the suspension bolt extends 20 mm or more from the surface of the ceiling. Otherwise you will not be able to install the cover panel (option).

3. If the long opening in the bracket and opening in the ceiling do not align, adjust them until they do.

Ⓐ Suspension bolt (3/8" or M10)

Ⓔ Washer ①

Ⓑ Ceiling surface

Ⓕ (Install with insulation facing down)

Ⓒ Nut (3/8" or M10)

Ⓖ Measurement to upper face of bracket

Ⓓ Washer ② (with insulation)

4. Check that the four corners are all level, using a spirit level or clear plastic tubing with water in it. (Fig. 2-8)

\* Make sure that any slant in the unit after installation is less than 0.5 degrees (approx. 6 mm on the long dimension of the unit).

5. Tighten all the nuts. (Fig. 2-9)

Ⓐ Suspension bolt (3/8" or M10)

Ⓑ Clear plastic tubing

Ⓒ Underside of bracket

Ⓓ Secure front panel here.

Ⓔ Make sure these surfaces are flush with each other (0 - 3 mm).

(mm)

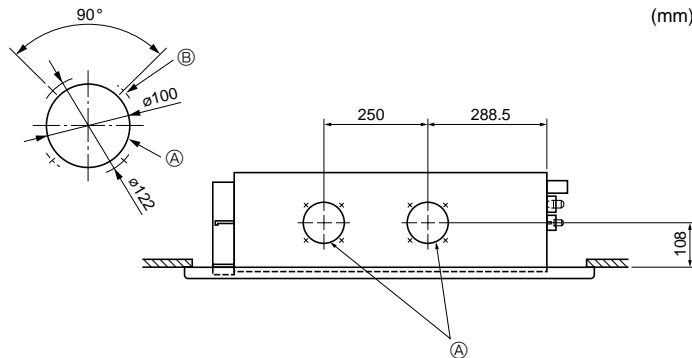

Fig. 2-10

### 2.5. Fresh air intake hole (Fig. 2-10)

At the time of installation, use the hole (knock out) located at the positions shown in following diagram, as and when required.

Ⓐ Fresh air intake hole (Knock out)

Ⓑ 4- $\phi$ 2.8 burring hole

**Note:**

**Make sure that the fresh air intake is no more than 20% of the entire air intake (when the air flow speed is set to its highest setting).**

**⚠ Caution:**

**Linkage of duct fan and air conditioner.**

**If a duct fan is used, be sure to link it with the air conditioner when outside air is taken in.**

**Do not run just the duct fan. Otherwise, condensation may form.**

## 3. Refrigerant pipe and drain pipe

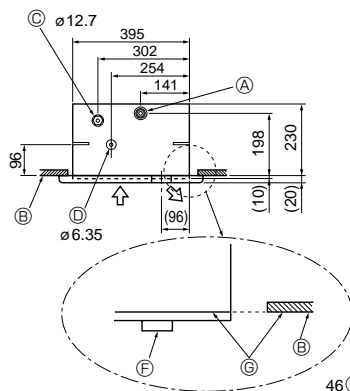

Fig. 3-1

(mm)

### 3.1. Refrigerant and drainage piping locations

Ⓐ Drain pipe (Use PVC pipe O.D.  $\phi$ 26)

Ⓑ Ceiling panel (under side)

Ⓒ Refrigerant pipe (gas)

Ⓓ Refrigerant pipe (liquid)

Ⓔ Electrical box

Ⓕ Drain pan

Ⓖ Make sure these surfaces are flush with each other.

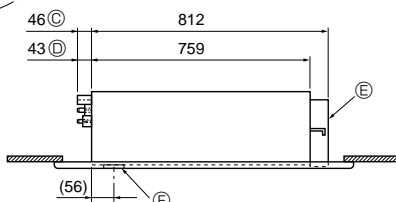

### 3. Refrigerant pipe and drain pipe

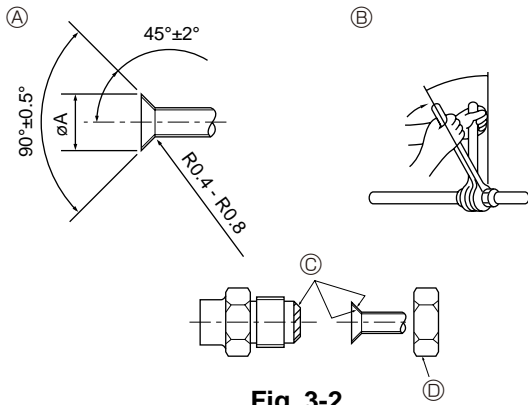

Fig. 3-2

#### 3.2. Connecting pipes (Fig. 3-2)

- When commercially available copper pipes are used, wrap liquid and gas pipes with commercially available insulation materials (heat-resistant to 100 °C or more, thickness of 12 mm or more).
- The indoor parts of the drain pipe should be wrapped with polyethylene foam insulation materials (specific gravity of 0.03, thickness of 9 mm or more).
- Apply thin layer of refrigerant oil to pipe and joint seating surface before tightening flare nut.
- Use 2 wrenches to tighten piping connections.
- Use refrigerant piping insulation provided to insulate indoor unit connections. Insulate carefully.

#### ⚠ Warning:

**When installing the unit, securely connect the refrigerant pipes before starting the compressor.**

Ⓐ Flare cutting dimensions

Copper pipe O.D. (mm)	Flare dimensions øA dimensions (mm)
ø6.35	8.7 - 9.1
ø9.52	12.8 - 13.2
ø12.7	16.2 - 16.6
ø15.88	19.3 - 19.7
ø19.05	23.6 - 24.0

Ⓑ Refrigerant pipe sizes & Flare nut tightening torque

	R407C or R22				R410A				Flare nut O.D.	
	Liquid pipe		Gas pipe		Liquid pipe		Gas pipe		Liquid pipe (mm)	Gas pipe (mm)
	Pipe size (mm)	Tightening torque (N.m)	Pipe size (mm)	Tightening torque (N.m)	Pipe size (mm)	Tightening torque (N.m)	Pipe size (mm)	Tightening torque (N.m)		
P20/25/32/40	O.D. ø6.35 (1/4")	14 - 18	O.D. ø12.7 (1/2")	49 - 61	O.D. ø6.35 (1/4")	14 - 18	O.D. ø12.7 (1/2")	49 - 61	17	26

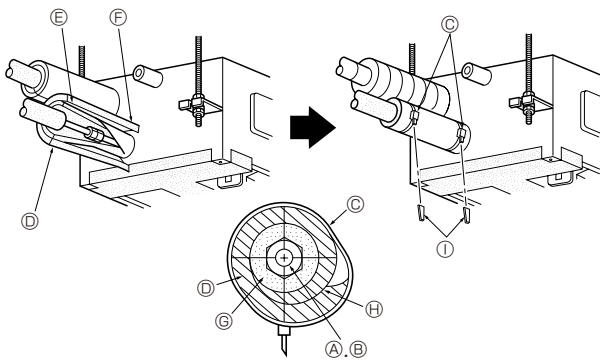

Fig. 3-3

Ⓒ Apply refrigerating machine oil over the entire flare seat surface.

\* Do not apply refrigerating machine oil to the screw portions. (This will make the flare nuts more apt to loosen.)

Ⓓ Be certain to use the flare nuts that are attached to the main unit. (Use of commercially-available products may result in cracking.)

Installing procedures (Fig. 3-3)

1. Remove the flare nuts and caps from the indoor unit.
2. Flare-cut the liquid and gas pipes then apply refrigerating machine oil (to be locally procured) over the flare-cut seat surface.
3. Quickly connect the refrigerant piping.
  - \* Remember to tighten the flare nuts with a double spanner.
4. Slide the supplied pipe cover ③ over the gas piping until it is pressed against the sheet metal inside the unit.
5. Slide the provided pipe cover ③ over the liquid piping until it is pressed against the sheet metal inside the unit.
6. Tighten the pipe cover ③ at the both ends (15 - 20 mm) with the supplied bands ④.
  - Ⓐ Gas piping
  - Ⓑ Liquid piping
  - Ⓒ Band (large) ④
  - Ⓓ Pipe cover ③
  - Ⓔ Turn the seam upward.
  - Ⓕ Press the pipe cover against the sheet metal.
  - Ⓖ Refrigerant piping heat insulating material
  - Ⓗ Wrap tightly.
  - Ⓘ Cut off excess length of band.

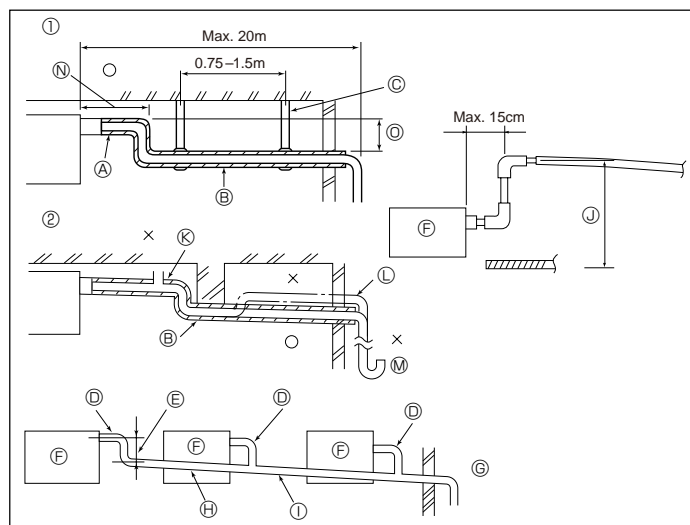

Fig. 3-4

#### 3.3. Drainage piping work (Fig. 3-4)

- Use O.D. ø26 mm PVC TUBE for drain piping and provide 1/100 or more downward slope.
- Be sure to connect the piping joints using adhesive of polyvinyl chloride family.
- Observe the figure for piping work.
- Use attached drain hose to change the pipe extraction direction.
  - ① Correct piping
  - ② Wrong piping
  - Ⓐ Insulation (9 mm or more)
  - Ⓑ Downward slope (1/100 or more)
  - Ⓒ Support metal
  - Ⓓ VP-20 (O.D. ø26 PVC TUBE)
  - Ⓔ Make it as large as possible.
  - Ⓕ Indoor unit
  - Ⓖ Make the piping size large for grouped piping.
  - Ⓚ Air bleeder
  - Ⓛ Raised
  - Ⓜ Odour trap
  - Ⓝ Make as little as possible.
  - Ⓞ Make as great as possible (approx. 10 cm).
  - Ⓢ Downward slope (1/100 or more)
  - Ⓣ O.D. ø38 PVC TUBE for grouped piping (9 mm or more insulation)
  - Ⓤ Up to 50 cm

### 3. Refrigerant pipe and drain pipe

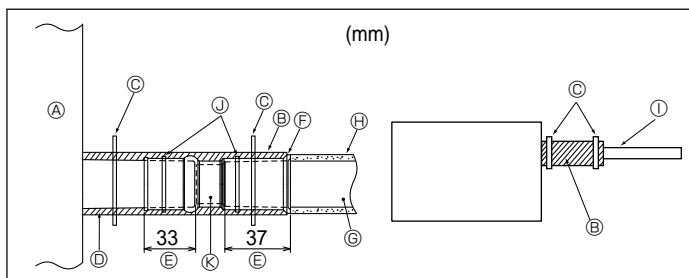

Fig. 3-5

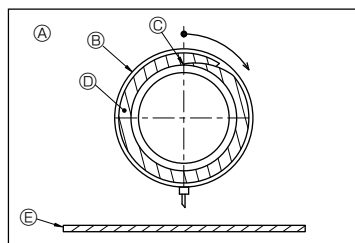

Fig. 3-6

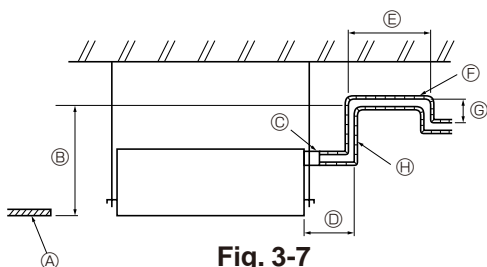

Fig. 3-7

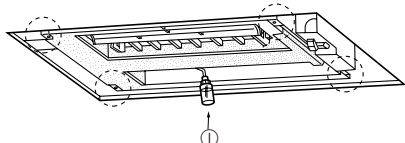

Fig. 3-8

1. Connect the drain socket (supplied with the unit) to the drain port. (Fig. 3-5) (Fix the tube using PVC adhesive then secure it with a band.)
2. Install a locally purchased drain pipe (PVC pipe, O.D.  $\phi 26$ ). (Fix the pipe using PVC adhesive then secure it with a band.)
3. Insulate the pipe. (PVC pipe, O.D.  $\phi 26$ )
4. Check that drain flows smoothly.
5. Insulate the drain port and drain socket with insulating material ⑦, then secure the material with a band. (Both insulating material and band are supplied with the unit.) (Fig. 3-6)

[Fig.3-5]

- ① Unit
- ② Insulating material ⑦
- ③ Band (large) ④
- ④ Drain port (transparent)
- ⑤ Insertion margin
- ⑥ Matching
- ⑦ Drain pipe (O.D.  $\phi 26$  PVC TUBE)
- ⑧ Insulating material (purchased locally)
- ⑨ O.D.  $\phi 26$  PVC TUBE (Slope 1/100 or more)
- ⑩ Band (small) ④
- ⑪ Drain socket

[Fig.3-6]

- ① Drain port sectional view
- ② Band (large) ④
- ③ Insulating material wrapping starting position (Top side)
- ④ Insulating material ⑦
- ⑤ Ceiling panel

#### In cases of upward drainage (Fig. 3-7)

- The largest dimension possible for the vertical section at ⑧ is 60 cm from the lower surface of the ceiling. Make this vertical section as short as possible.

#### Water drainage check (Fig. 3-8)

1. Fill the drainage pan with about 0.5 litres of water. (Do not pour water directly into the drain pump.)
  2. Make a test run of the unit (in Cooling mode).
  3. Check for water drainage at the transparent check window and the outlet of the drainage pipe.
  4. Stop the test run. (Do not forget to turn off the power.)
- ① Ceiling panel
  - ② Max. 60 cm
  - ③ Position of drain outlet
  - ④ Make as short as possible (Max. 15 cm).
  - ⑤ Make as small as possible.
  - ⑥ Downward slope (1/100 or more)
  - ⑦ Make as great as possible (Min. 10 cm).
  - ⑧ Drainage pipe vertical section
  - ⑨ Water bottle (procure locally)

### 4. Electrical work

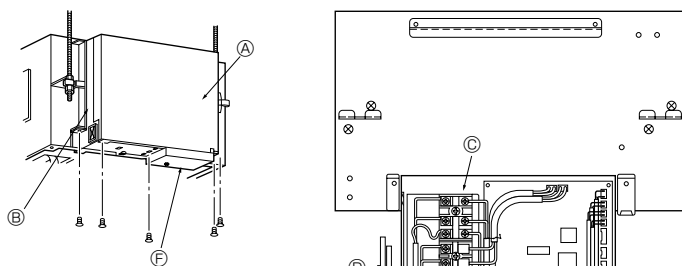

- ① Cover
- ② Electrical box
- ③ Terminal block for power supply
- ④ Terminal block for transmission cable
- ⑤ Control board
- ⑥ Address board
- ⑦ Secure with the wiring clamp.
- ⑧ Terminal block for MA Remote controller

Fig. 4-1

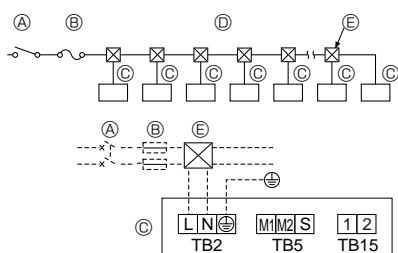

Fig. 4-2

#### 4.1. Electric wiring (Fig. 4-1)

\* Make sure all electrical wiring is complete before installing the cover panel.

1. Install an earth longer than other cables.
2. Remove the cover from the address board (2 bolts).
3. Remove the bolts securing the electrical box and lower the box (2 bolts).
4. Insert the wires into the electrical box.
5. Connect the wires securely to the terminal block.

\* Be sure to make the various wires long enough so the box may be lowered from the unit during servicing.

6. Secure the wires with the wiring clamp on the side of the electrical box.
7. Replace the parts you have removed to their original locations.

#### 4.2. Power supply wiring

- Wiring size must comply with the applicable local and national code.
  - Install an earth longer than other cables.
  - Power supply codes of appliance shall not be lighter than design 60245 IEC 53 or 60227 IEC 53.
  - A switch with at least 3 mm contact separation in each pole shall be provided by the air conditioner installation.
- Power cable size : more than 1.5 mm<sup>2</sup> (3-core)

#### ⚠ Warning:

Never splice the power cable or the indoor-outdoor connection cable, otherwise it may result in a smoke, a fire or communication failure.

#### ▶ Use earth leakage breaker (NV).

For breaker, means shall be provided to ensure disconnection of all active phase conductors of the supply.

[Fig. 4-2]

- ① Switch 16 A
- ② Overcurrent protection 16 A
- ③ Indoor unit
- ④ Total operating current be less than 16 A
- ⑤ Pull box

## 4. Electrical work

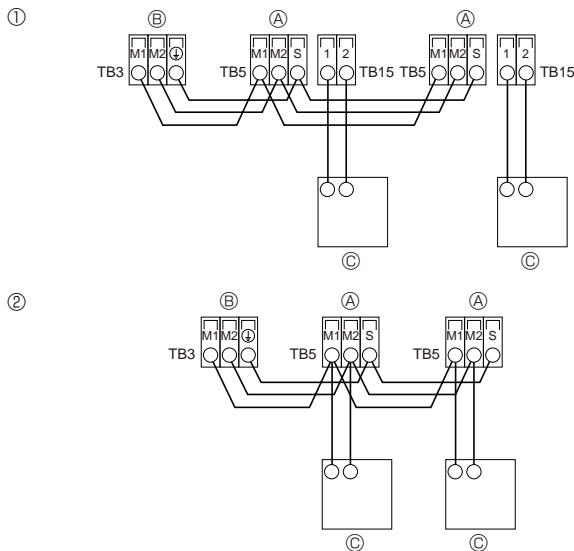

Fig. 4-3

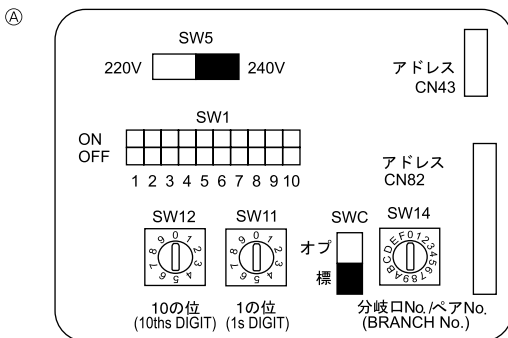

Fig. 4-4

### 4.3. Types of control cables

#### 1. Wiring transmission cables

Types of transmission cable	Shielding wire CVVS or CPEVS
Cable diameter	More than 1.25 mm <sup>2</sup>
Length	Less than 200 m

#### 2. M-NET Remote control cables

Types of remote control cable	Shielding wire MVVS
Cable diameter	0.5 to 1.25 mm <sup>2</sup>
Length	Add any portion in excess of 10 m to within the longest allowable transmission cable length 200 m

#### 3. MA Remote control cables

Types of remote control cable	2-core cable (unshielded)
Cable diameter	0.3 to 1.25 mm <sup>2</sup>
Length	Less than 200 m

### 4.4. Connecting remote controller, indoor and outdoor transmission cables (Fig. 4-3)

- Connect indoor unit TB5 and outdoor unit TB3. (Non-polarized 2-wire)  
The "S" on indoor unit TB5 is a shielding wire connection. For specifications about the connecting cables, refer to the outdoor unit installation manual.
  - Install a remote controller following the manual supplied with the remote controller.
  - Connect the remote controller's transmission cable within 10 m using a 0.75 mm<sup>2</sup> core cable. If the distance is more than 10 m, use a 1.25 mm<sup>2</sup> junction cable.
- ① MA Remote controller
- Connect the "1" and "2" on indoor unit TB15 to a MA remote controller. (Non-polarized 2-wire)
  - DC 9 to 13 V between 1 and 2 (MA remote controller)
- ② M-NET Remote controller
- Connect the "M1" and "M2" on indoor unit TB5 to a M-NET remote controller. (Non-polarized 2-wire)
  - DC 24 to 30 V between M1 and M2 (M-NET remote controller)
- Ⓐ Terminal block for indoor transmission cable  
Ⓑ Terminal block for outdoor transmission cable  
Ⓒ Remote controller

### 4.5. Setting addresses (Fig. 4-4)

(Be sure to operate with the main power turned OFF.)

- There are 2 types of rotary switch setting available: setting addresses 1 to 9 and over 10, and setting branch numbers.
- ① How to set addresses
- Example: If Address is "3", remain SW12 (for over 10) at "0", and match SW11 (for 1 to 9) with "3".
- ② How to set branch numbers SW14 (Series R2 only)
- Match the indoor unit's refrigerant pipe with the BC controller's end connection number.
- Remain other than series R2 at "0".
- The rotary switches are all set to "0" when shipped from the factory. These switches can be used to set unit addresses and branch numbers at will.
  - The determination of indoor unit addresses varies with the system at site. Set them referring to the Data Book.

#### Note:

- Please set the switch SW5 according to the power supply voltage.
  - Set SW5 to 240 V side when the power supply is 230 and 240 volts.
  - When the power supply is 220 volts, set SW5 to 220 V side.
- Ⓐ Address board

### 4.6. Sensing room temperature with the built-in sensor in a remote controller (Fig. 4-4)

If you want to sense room temperature with the built-in sensor in a remote controller, set SW1-1 on the control board to "ON". The setting of SW1-7 and SW1-8 as necessary also makes it possible to adjust the airflow at a time when the heating thermometer is OFF.

## 5. Installing the grille

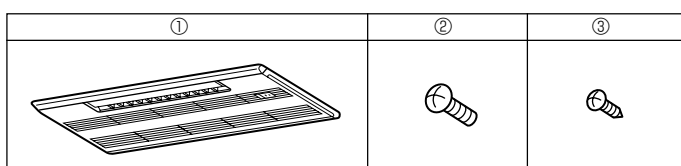

Fig. 5-1

### 5.1. Checking the contents (Fig. 5-1)

- This kit contains the following parts.

	Accessory name	Q'ty	Remark
①	Grille	1	
②	Screw	6	M5 x 0.8 x 16
③	Screw	1	4 x 16

## 5. Installing the grille

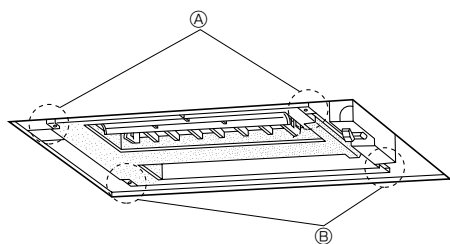

Fig. 5-2

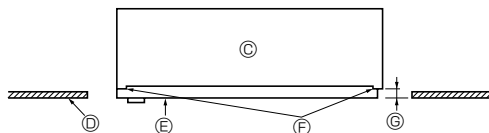

Fig. 5-3

- Ⓐ Points for securing the grille
- Ⓑ Points for securing the grille
- Ⓒ Indoor unit
- Ⓓ Ceiling surface
- Ⓔ Drainage pan
- Ⓕ Places for securing front grille
- Ⓖ Make sure these surfaces are flush with each other (0 - 3 mm).

### 5.2. Checks before setting in place (Fig. 5-2, 3)

- Before installing the front panel, make sure the indoor unit is square with the ceiling opening (or parallel to the angle between the wall and the ceiling).
- Check that the four points where the front panel will be secured are in contact with the ceiling surface.
- Check that the insulation for the refrigerant pipes, drainage pipes, etc. is in place and that wiring connections and arrangements are complete.

### 5.3. Installing the grille (Fig. 5-4)

- Open the intake grille by pressing on the place marked Push, and remove the air filter.
- Remove the screw cover in the middle of the blower.
- Open the upper and lower flaps on the indoor unit completely.
- Hook the temporary holding tabs on the front panel to the hooks on the indoor unit.

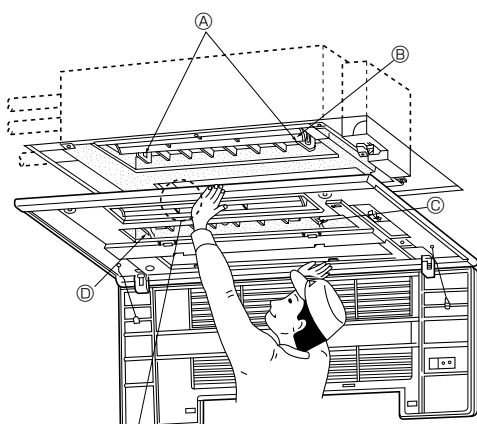
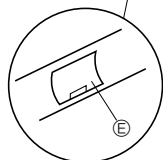

Fig. 5-4



- Ⓐ Hooks
- Ⓑ Open the upper and lower flaps completely.
- Ⓒ Temporary holding tab
- Ⓓ Temporary holding tab
- Ⓔ Screw cover

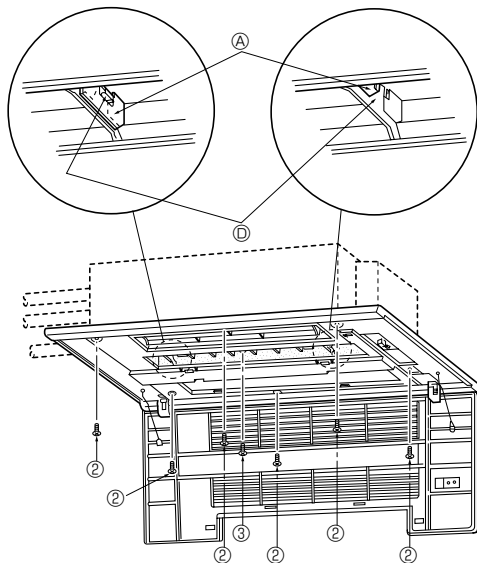

Fig. 5-5

- Adjust the front panel so that it fits properly in the angle between the ceiling and the wall, and install the securing bolts Ⓔ (supplied with this grille) in their four places at left and right, leaving them slightly loose. (Fig. 5-5)
- Next tighten the securing bolts Ⓔ and securing screws Ⓕ in the centre three places.
- Finally tighten the securing bolts Ⓔ in the four places at left and right.
- At this point, make sure there are no gaps between the indoor unit and the front panel, and between the front panel and the ceiling surface. If there are gaps, the wind may come in and it may cause water to drip (Fig. 5-6).
- \* Tighten the securing bolts Ⓔ and securing screws Ⓕ completely.
- Replace the air filter and screw cover, and press the intake grille on the place marked Push until you hear it snap into place.

#### [Fig. 5-5]

- Ⓐ Hooks
- Ⓑ Temporary securing tab



## 5. Installing the grille

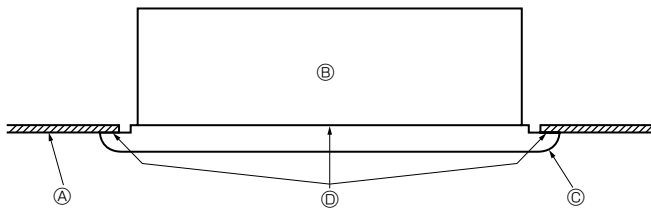

Fig. 5-6

### 5.4. Checks after installing (Fig. 5-6)

- Check that there are no gaps between the indoor unit and the front panel, between the front panel and the ceiling surface. If there are gaps, the wind may come in and condensation may result.
- Check that the air filter is in place.
  - Ⓐ Ceiling surface
  - Ⓑ Indoor unit
  - Ⓒ Grille
  - Ⓓ No gaps here

## 6. Test run

### 6.1. Before test run

- ▶ After completing installation and the wiring and piping of the indoor and outdoor units, check for refrigerant leakage, looseness in the power supply or control wiring, wrong polarity, and no disconnection of 1 phase in the supply.
- ▶ Use a 500-volt megohmmeter to check that the resistance between the power supply terminals and ground is at least 1.0 MΩ.

- ▶ Do not carry out this test on the control wiring (low voltage circuit) terminals.

#### ⚠ Warning:

Do not use the air conditioner if the insulation resistance is less than 1.0 MΩ.

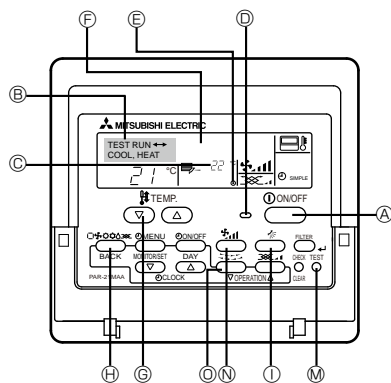

- Ⓐ ON/OFF button
- Ⓑ Test run display
- Ⓒ Liquid pipe (Indoor unit) temperature display
- Ⓓ ON/OFF lamp
- Ⓔ Power display
- Ⓕ Error code display
- Ⓖ Test run remaining time display
- Ⓗ Set temperature button
- Ⓘ Mode selection button
- Ⓚ Air direction button
- Ⓛ TEST button
- Ⓝ Fan Speed button
- Ⓞ Louver button

Fig. 6-1

### 6.2. Test run

#### Using wired remote controller (Fig. 6-1)

- ① Turn on the power at least 12 hours before the test run.
- ② Press the [TEST] button twice. ➡ "TEST RUN" liquid crystal display
- ③ Press the [Mode selection] button and switch to the cooling (or heating) mode. ➡ Make sure that cold (or warm) wind is blown out.
- ④ Press the [Fan speed] button. ➡ Make sure that the wind speed is switched.
- ⑤ Press the [Air direction button] or [Louver button]. ➡ Check operation of the vane or louver.
- ⑥ Check operation of the outdoor unit fan.
- ⑦ Release test run by pressing the [ON/OFF] button. ➡ Stop
- ⑧ Register a telephone number.

The telephone number of the repair shop, sales office, etc., to contact if an error occurs can be registered in the remote controller. The telephone number will be displayed when an error occurs. For registration procedures, refer to the operation manual for the indoor unit.

#### Note:

- If an error code is displayed on the remote controller or if the air conditioner does not operate properly, refer to the outdoor unit installation manual or other technical materials.
- The OFF timer is set for the test run to automatically stop after 2 hours.
- During the test run, the time remaining is shown in the time display.
- During the test run, the temperature of the indoor unit refrigerant pipes is shown in the room temperature display of the remote controller.
- When the VANE or LOUVER button is pressed, the message "NOT AVAILABLE" may appear on the remote controller display depending on the indoor unit model, but this is not a malfunction.

---

This product is designed and intended for use in the residential,  
commercial and light-industrial environment.

The product at hand is  
based on the following  
EU regulations:

- Low Voltage Directive 2006/95/EC
- Electromagnetic Compatibility Directive 2004/108/EC
- Machinery Directive 2006/42/EC
- Energy-related Products Directive 2009/125/EC

Please be sure to put the contact address/telephone number on  
this manual before handing it to the customer.

## **MITSUBISHI ELECTRIC CORPORATION**

HEAD OFFICE: TOKYO BLDG., 2-7-3, MARUNOUCHI, CHIYODA-KU, TOKYO 100-8310, JAPAN  
Authorized representative in EU: MITSUBISHI ELECTRIC EUROPE B.V.

HARMAN HOUSE, 1 GEORGE STREET, UXBRIDGE, MIDDLESEX UB8 1QQ, U.K.