

December 2012

No. OCB413

REVISED EDITION-E

PARTS CATALOG

Series PLFY Ceiling Cassettes

R410A
Indoor unit
[Model names]
[Service Ref.]

PLFY-P32VBM-E

PLFY-P32VBM-E.UK

 PLFY-P32VBM-E₁.UK

PLFY-P32VBM-ER2.UK

PLFY-P32VBM-ER3.UK

PLFY-P40VBM-E

PLFY-P40VBM-E.UK

 PLFY-P40VBM-E₁.UK

PLFY-P40VBM-ER2.UK

PLFY-P40VBM-ER3.UK

PLFY-P50VBM-E

PLFY-P50VBM-E.UK

 PLFY-P50VBM-E₁.UK

PLFY-P50VBM-ER2.UK

PLFY-P50VBM-ER3.UK

PLFY-P63VBM-E

PLFY-P63VBM-E.UK

 PLFY-P63VBM-E₁.UK

PLFY-P63VBM-ER2.UK

PLFY-P63VBM-ER3.UK

PLFY-P80VBM-E

PLFY-P80VBM-E.UK

 PLFY-P80VBM-E₁.UK

PLFY-P80VBM-ER2.UK

PLFY-P80VBM-ER3.UK

PLFY-P100VBM-E

PLFY-P100VBM-E.UK

PLFY-P100VBM-ER2.UK

PLFY-P100VBM-ER3.UK

PLFY-P125VBM-E

PLFY-P125VBM-E.UK

PLFY-P125VBM-ER2.UK

PLFY-P125VBM-ER3.UK

Revision:

- PLFY-P32/40/50/63/80/100/125VBM-ER3 have been added in REVISED EDITION-E.
- Some descriptions have been modified.

- Please void OCB413 REVISED EDITION-D.

Note:

- RoHS compliant products have <G> mark on the spec name plate.

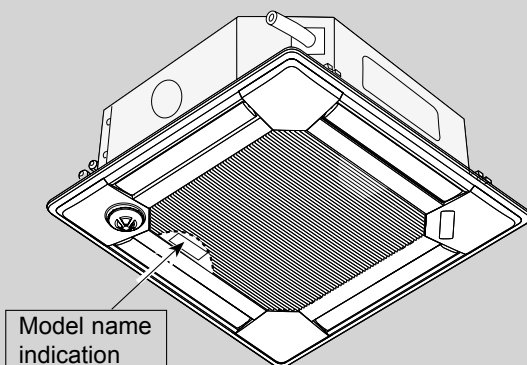

INDOOR UNIT

CONTENTS

1. RoHS PARTS LIST..... 2
2. OPTIONAL PARTS..... 7

SERVICE MANUAL (OCH413)

PANEL PARTS

PLP-6BA (Standard)

PLP-6BAE (i-see sensor)

PLP-6BAJ (Auto descending panel)

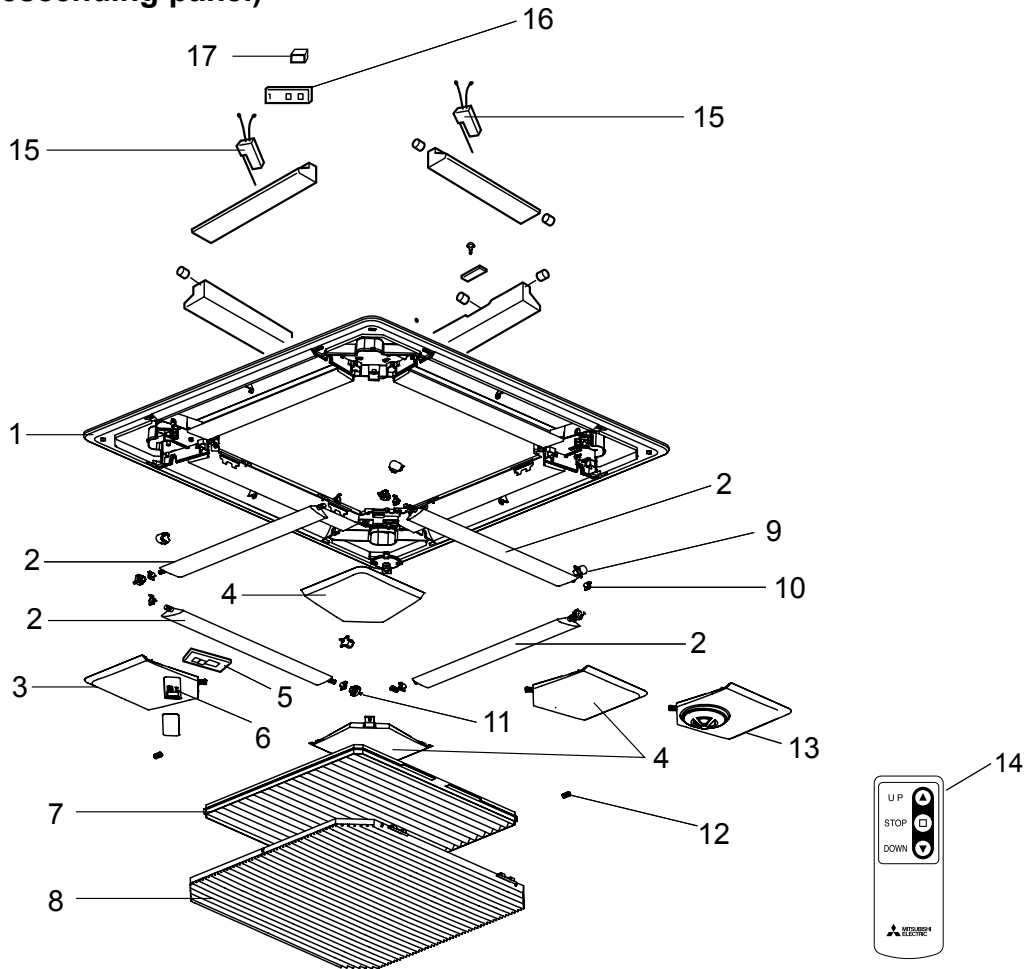

Part numbers that are circled are not shown in the illustration.

No.	RoHS	Parts No.	Parts Name	Specification	Q'ty/unit			Remarks (Drawing No.)	Wiring Diagram Symbol	Recom- mended Q'ty
					BA	BAE	BAJ			
1	G	S70 E20 003	AIR OUTLET GRILLE		1	1	1			
2	G	S70 E20 002	VANE ASSY		4	4	4			
3	G	S70 E31 638	CORNER PANEL (L)		1	1				
	G	S70 E41 638	CORNER PANEL (L)				1			
4	G	S70 E20 638	CORNER PANEL		3	2	3			
5	G	S70 E20 317	WIRELESS ADAPTER				1	W.B		
6	G	S70 E50 658	RECEIVER				1	RU		
7	G	S70 E20 500	L. L. FILTER-A		1	1	1			
8	G	S70 E20 691	GRILLE ASSY		1	1				
	G	S70 E30 691	GRILLE ASSY				1			
9	G	S70 E00 223	STEPPING MOTOR		4	4	4	MV		
10	G	S70 E00 063	VANE BUSH-A		8	8	8			
11	G	S70 E00 040	GEAR (Vane)		4	4	4			
12	G	S70 E01 040	GEAR (S/M)		4	4	4			
13	G	—	I-SEE SENSOR	PAC-SA1ME-E			1			
14	G	S70 E60 714	REMOTE CONTROLLER				1	for Auto Grille		
15	G	S70 0B0 213	MOTOR BOX				2	UK1		
16	G	S70 0B6 310	CONTROLLER BOARD				1	U.B		
17	G	S70 0B0 512	LIMIT SWITCH				1	LS1		
(18)	G	S70 E20 305	CABLE ASSY				1	for W.B.		
(19)	G	S70 E20 673	SCREW ASSY		1	1	1	Accessory		

RoHS PARTS LIST

STRUCTURAL AND FUNCTIONAL PARTS

PLFY-P32VBM-E.UK
 PLFY-P40VBM-E.UK
 PLFY-P50VBM-E.UK
 PLFY-P63VBM-E.UK
 PLFY-P80VBM-E.UK
 PLFY-P100VBM-E.UK
 PLFY-P125VBM-E.UK
 PLFY-P32VBM-E1.UK
 PLFY-P40VBM-E1.UK
 PLFY-P50VBM-E1.UK
 PLFY-P63VBM-E1.UK
 PLFY-P80VBM-E1.UK
 PLFY-P32VBM-ER2.UK
 PLFY-P40VBM-ER2.UK
 PLFY-P50VBM-ER2.UK
 PLFY-P63VBM-ER2.UK
 PLFY-P80VBM-ER2.UK
 PLFY-P100VBM-ER2.UK
 PLFY-P125VBM-ER2.UK

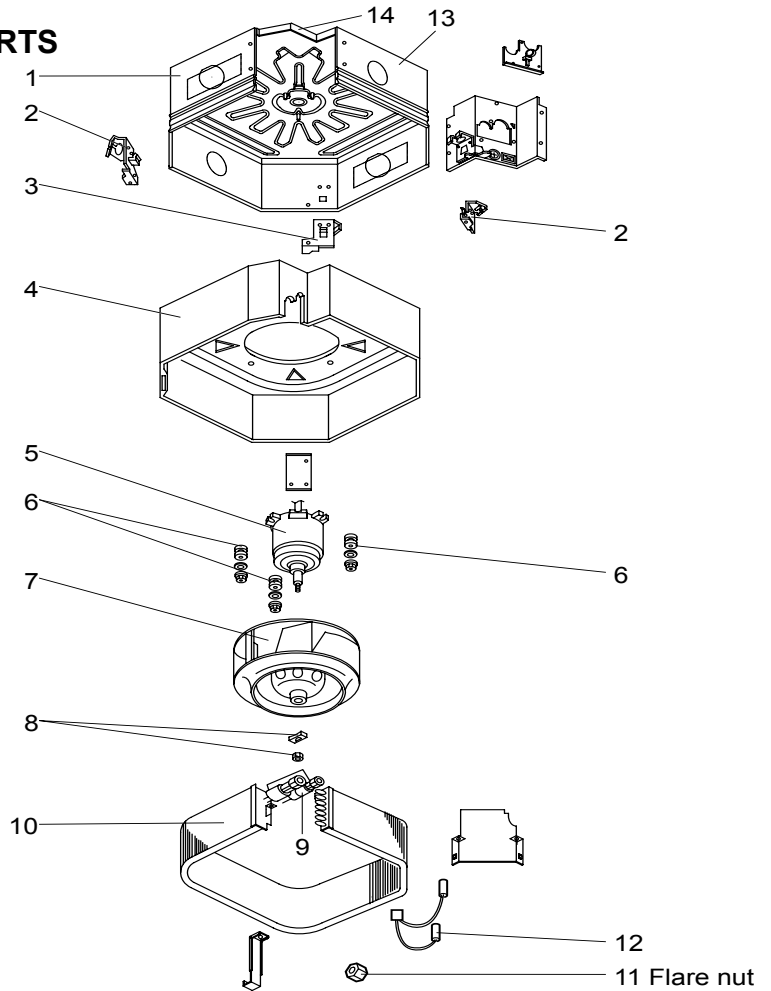

No.	RoHS	Parts No.	Parts Name	Specif- cation	Q'ty/unit															Remarks (Drawing No.)	Wiring Daigram Symbol	Recom- mended Q'ty			
					PLFY-P-VBM-E.UK					PLFY-P-VBM-E1.UK					PLFY-P-VBM-ER2.UK										
					32	40	50	63	80	32	40	50	63	80	32	40	50	63	80						
1	G	S70 0B3 688	DRUM 2 ASSY		1	1	1	1	1	1	1	1	1	1	1	1	1	1	1	1	1	1			
	G	S70 0B4 688	DRUM 2 ASSY						1												1				
2	G	S70 0B2 130	LEG 1A		2	2	2	2	2	2	2	2	2	2	2	2	2	2	2	2	2	2			
3	G	S70 0B1 130	LEG 1B		1	1	1	1	1	1	1	1	1	1	1	1	1	1	1	1	1	1			
4	G	S70 0B1 659	INNER COVER ASSY - S		1	1	1	1	1	1	1	1	1	1	1	1	1	1	1	1	1	1			
	G	S70 0B2 659	INNER COVER ASSY - L						1												1				
5	G	S70 0B1 762	FAN MOTOR		1	1	1	1	1	1															MF
	G	S70 0B2 762	FAN MOTOR						1		1	1	1	1	1	1	1	1	1	1	1	1			MF
	G	S70 0B3 762	FAN MOTOR							1	1	1	1	1	1	1	1	1	1	1	1	1			MF
6	G	S70 0B1 105	MOTOR MOUNT		3	3	3	3	3	3	3	3	3	3	3	3	3	3	3	3	3	3			
7	G	S70 0B1 114	TURBO FAN		1	1	1	1	1	1															
	G	S70 0B2 114	TURBO FAN						1												1				
	G	S70 0B3 114	TURBO FAN							1	1	1	1	1	1	1	1	1	1	1	1	1			
8	G	S70 08K 097	SPL WASHER/NUT	M8	1	1	1	1	1	1											1				
	G	S70 10B 097	SPL WASHER/NUT	M6							1	1	1	1	1	1	1	1	1	1	1				
9	G	S70 0B1 401	LINEAR EXPANSION VALVE		1	1	1	1			1	1	1	1			1	1	1	1					LEV
	G	S70 0B2 401	LINEAR EXPANSION VALVE						1	1					1						1	1			LEV
10	G	S70 0C1 480	HEAT EXCHANGER		1						1						1								
	G	S70 0C2 480	HEAT EXCHANGER			1							1						1						
	G	S70 0C3 480	HEAT EXCHANGER				1							1											
	G	S70 0C4 480	HEAT EXCHANGER					1							1						1				
	G	S70 0C5 480	HEAT EXCHANGER						1							1									
	G	S70 0C6 480	HEAT EXCHANGER							1															
	G	S70 0C7 480	HEAT EXCHANGER																		1				
	G	S70 0C8 480	HEAT EXCHANGER																			1			
11	G	S70 E17 097	FLARE NUT	3/8"				1						1					1	1	1	1			
	G	S70 E15 097	FLARE NUT	5/8"				1						1					1	1	1				
	G	S70 E16 097	FLARE NUT	3/4"					1													1			
12	G	S70 0B2 202	THERMISTOR		1	1	1	1	1	1	1	1	1	1	1	1	1	1	1	1	1	1			TH22/TH23
13	G	S70 0B1 688	DRUM 1 ASSY		1	1	1	1	1	1	1	1	1	1	1	1	1	1	1	1	1	1			
	G	S70 0B2 688	DRUM 1 ASSY						1													1			
14	G	S70 0B1 687	BASE		1	1	1	1	1	1	1	1	1	1	1	1	1	1	1	1	1	1			

RoHS PARTS LIST

STRUCTURAL AND FUNCTIONAL PARTS

PLFY-P32VBM-ER3.UK
 PLY-P40VBM-ER3.UK
 PLY-P50VBM-ER3.UK
 PLY-P63VBM-ER3.UK
 PLY-P80VBM-ER3.UK
 PLY-P100VBM-ER3.UK
 PLY-P125VBM-ER3.UK

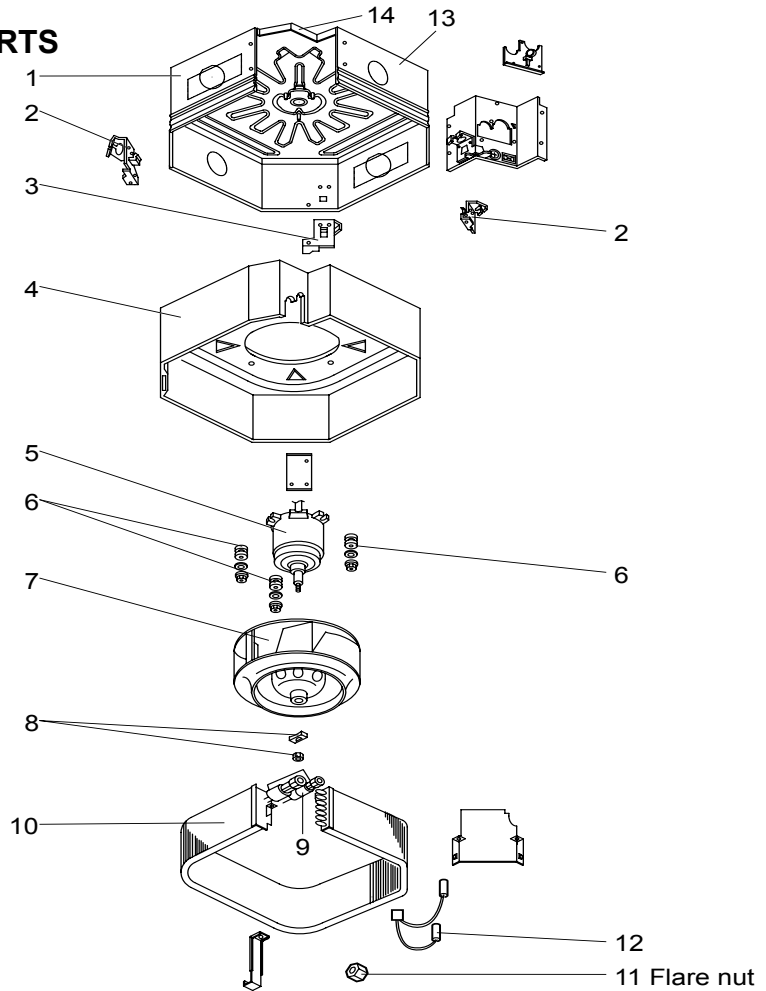

No.	RoHS	Parts No.	Parts Name	Specif cation	Q'ty/unit						Remarks (Drawing No.)	Wiring Daigram Symbol	Recom-mended Q'ty	
					PLFY-P-VBM-ER3.UK									
					32	40	50	63	80	100	125			
1	G	S70 0B3 688	DRUM 2 ASSY		1	1	1	1	1					
	G	S70 0B4 688	DRUM 2 ASSY							1	1			
2	G	S70 0B2 130	LEG 1A		2	2	2	2	2	2	2			
3	G	S70 0B1 130	LEG 1B		1	1	1	1	1	1	1			
4	G	S70 0B1 659	INNER COVER ASSY - S		1	1	1	1	1					
	G	S70 0B2 659	INNER COVER ASSY - L							1	1			
5	G	S70 0B3 762	FAN MOTOR		1	1	1	1	1				MF	
	G	S70 0B2 762	FAN MOTOR							1	1		MF	
6	G	S70 0B1 105	MOTOR MOUNT		3	3	3	3	3	3	3			
7	G	S70 0B3 114	TURBO FAN		1	1	1	1	1					
	G	S70 0B2 114	TURBO FAN							1	1			
8	G	S70 10B 097	SPL WASHER/NUT	M6	1	1	1	1	1					
	G	S70 08K 097	SPL WASHER/NUT	M8						1	1			
9	G	S70 0B1 401	LINEAR EXPANSION VALVE		1	1	1	1					LEV	
	G	S70 0B2 401	LINEAR EXPANSION VALVE						1	1	1		LEV	
10	G	S70 0C1 480	HEAT EXCHANGER		1									
	G	S70 0C2 480	HEAT EXCHANGER			1								
	G	S70 0C7 480	HEAT EXCHANGER				1							
	G	S70 0C4 480	HEAT EXCHANGER					1						
	G	S70 0C5 480	HEAT EXCHANGER						1					
	G	S70 0C8 480	HEAT EXCHANGER							1	1			
11	G	S70 E17 097	FLARE NUT	3/8"				1	1	1	1			
	G	S70 E15 097	FLARE NUT	5/8"				1	1	1	1			
12	G	S70 0B2 202	THERMISTOR		1	1	1	1	1	1	1		TH22/TH23	
13	G	S70 0B1 688	DRUM 1 ASSY		1	1	1	1	1					
	G	S70 0B2 688	DRUM 1 ASSY							1	1			
14	G	S70 0B1 687	BASE		1	1	1	1	1	1	1			

RoHS PARTS LIST

FUNCTIONAL AND ELECTRICAL PARTS

PLFY-P32VBM-E.UK
 PLFY-P40VBM-E.UK
 PLFY-P50VBM-E.UK
 PLFY-P63VBM-E.UK
 PLFY-P80VBM-E.UK
 PLFY-P100VBM-E.UK
 PLFY-P125VBM-E.UK
 PLFY-P32VBM-E₁.UK
 PLFY-P40VBM-E₁.UK
 PLFY-P50VBM-E₁.UK
 PLFY-P63VBM-E₁.UK
 PLFY-P80VBM-E₁.UK
 PLFY-P32VBM-ER2.UK
 PLFY-P40VBM-ER2.UK
 PLFY-P50VBM-ER2.UK
 PLFY-P63VBM-ER2.UK
 PLFY-P80VBM-ER2.UK
 PLFY-P100VBM-ER2.UK
 PLFY-P125VBM-ER2.UK

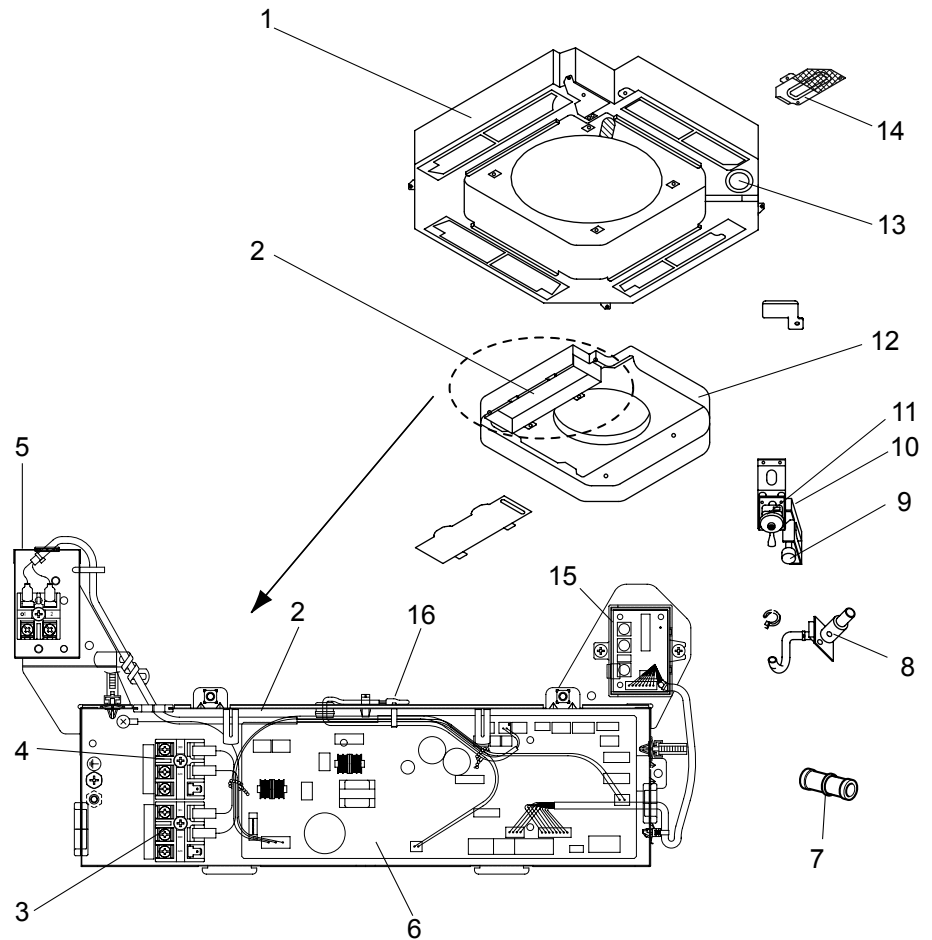

No.	RoHS	Parts No.	Parts Name	Specification	Qty/unit			Remarks (Drawing No.)	Wiring Diagram Symbol
					PLFY-P-VBM-E.UK 32/40/50/63/80/100/125	PLFY-P-VBM-E ₁ .UK 32/40/50/63/80	PLFY-P-VBM-ER2.UK 32/40/50/63/80/100/125		
1	G	S70 0B2 529	DRAIN PAN		1	1	1		
2	G	S70 0B6 501	ELECTRICAL CONTROL BOX		1	1	1		
3	G	S70 B02 716	TERMINAL BLOCK	3P (M1,M2,S)	1	1	1		TB4
4	G	S70 0B4 716	TERMINAL BLOCK	3P (L, N, ⊕)	1	1	1		TB2
5	G	S70 512 716	TERMINAL BLOCK	2P (1,2)	1	1	1		TB15
6	G	S70 0B5 310	INDOOR CONTROLLER BOARD		1	1			I.B
	G	S70 0B4 310	INDOOR CONTROLLER BOARD				1		I.B
7	G	S70 29H 523	DRAIN SOCKET		1	1	1	ACCESSORY	
8	G	S70 0B1 527	DRAIN HOSE ASSY		1	1	1		
9	G	S70 0B1 266	DRAIN SENSOR (Float Switch)		1	1	1		FS
10	G	S70 0B1 533	DRAIN SENSOR HOLDER		1	1	1		
11	G	S70 0B1 355	DRAIN PUMP		1	1	1		DP
12	G	S70 0B2 502	BELLMOUTH		1	1	1		
13	G	S70 A41 524	DRAIN PLUG		1	1	1		
14	G	S70 0B1 663	CORNER COVER		1	1	1		
15	G	S70 0B1 313	ADDRESS BOARD		1	1	1		A.B
16	G	S70 0B1 202	ROOM TEMP. THERMISTOR		1	1	1		TH21

RoHS PARTS LIST

FUNCTIONAL AND ELECTRICAL PARTS

PLFY-P32VBM-ER3.UK
 PLY-P40VBM-ER3.UK
 PLY-P50VBM-ER3.UK
 PLY-P63VBM-ER3.UK
 PLY-P80VBM-ER3.UK
 PLY-P100VBM-ER3.UK
 PLY-P125VBM-ER3.UK

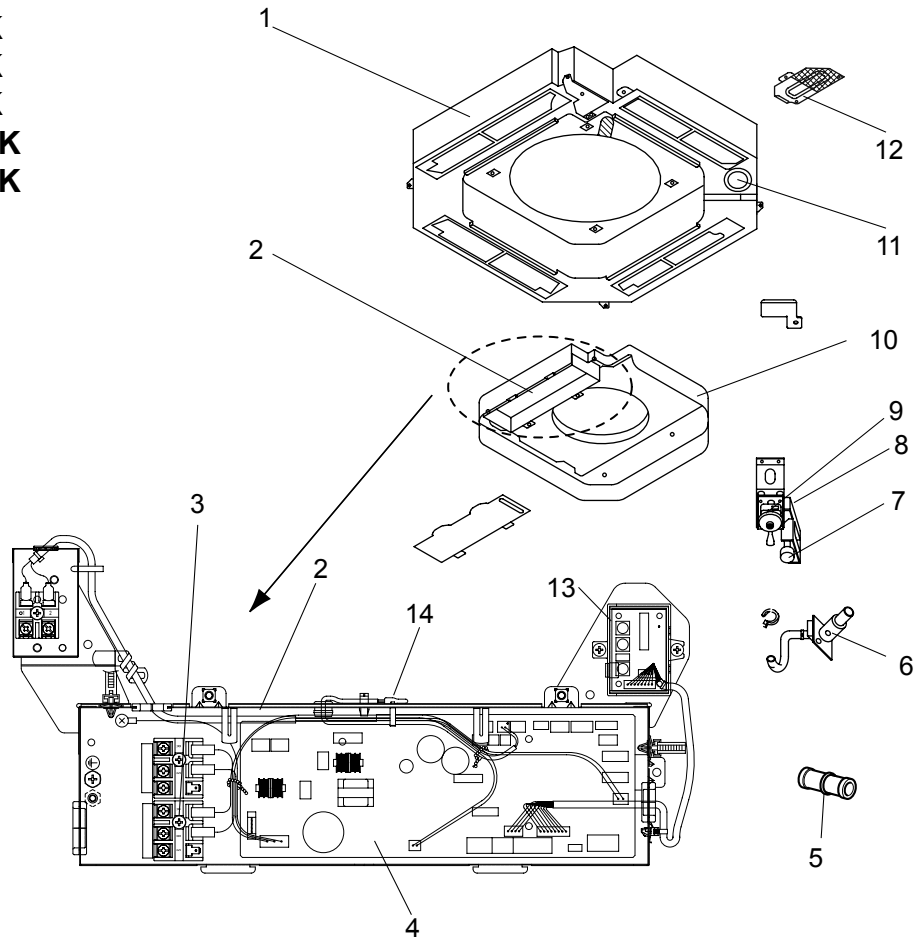

No.	RoHS	Parts No.	Parts Name	Specification	Qty/unit		Remarks (Drawing No.)	Wiring Diagram Symbol
					PLFY-P-VBM-ER3.UK	32/40/50/63/80/100/125		
1	G	S70 0B2 529	DRAIN PAN		1			
2	G	S70 0B6 501	ELECTRICAL CONTROL BOX		1			
3	G	S70 B02 716	TERMINAL BLOCK	3P (M1,M2,S) (L,N,⊕)	2			TB4/TB2
4	G	S70 0B3 310	INDOOR CONTROLLER BOARD		1			I.B
5	G	S70 29H 523	DRAIN SOCKET		1			
6	G	S70 0B1 527	DRAIN HOSE ASSY		1			
7	G	S70 0B1 266	DRAIN SENSOR (Float Switch)		1			FS
8	G	S70 0B1 533	DRAIN SENSOR HOLDER		1		ACCESSORY	
9	G	S70 0B1 355	DRAIN PUMP		1			DP
10	G	S70 0B2 502	BELLMOUTH		1			
11	G	S70 A41 524	DRAIN PLUG		1			
12	G	S70 0B1 663	CORNER COVER		1			
13	G	S70 0B1 313	ADDRESS BOARD		1			A.B
14	G	S70 0B1 202	ROOM TEMP. THERMISTOR		1			TH21

2**OPTIONAL PARTS****2-1. OPTIONAL PARTS LIST****2-1-1. MULTI FUNCTION CASEMENT**

Part No.	PAC-SH53TM-E
----------	--------------

2-1-2. AIR OUTLET SHUTTER PLATE

Part No.	PAC-SH51SP-E
----------	--------------

2-1-3. HIGH EFFICIENCY FILTER (PAC-SH53TM-E is required in using this optional part.)

Part No.	PAC-SH59KF-E
----------	--------------

2-1-4. i-SEE SENSOR CORNER PANEL

Part No.	PAC-SA1ME-E
----------	-------------

2-1-5. AUTOMATIC FILTER ELEVATION PANEL

Part No.	PLP-6BAJ
----------	----------

2-1-6. SPACE PANEL

Part No.	PAC-SH48AS-E
----------	--------------

2-1-7. FLANGE FOR FRESH AIR INTAKE

Part No.	PAC-SH65OF-E
----------	--------------

2-1-8. WIRELESS SIGNAL RECEIVER (CORNER PANEL)

Part No.	PAR-SA9FA-E
----------	-------------

2-1-9. WIRELESS REMOTE CONTROLLER

Part No.	PAR-FL32MA
----------	------------

2-1-10. WIRED REMOTE CONTROLLER (MA REMOTE CONTROLLER)

Part No.	PAR-21MAA PAR-30MAA PAR-31MAA
----------	-------------------------------------

2-1-11. WIRED REMOTE CONTROLLER (ME REMOTE CONTROLLER)

Part No.	PAR-F27MEA
----------	------------

2-1-12. DECORATION PANEL

Part No.	PLP-6BA
----------	---------

CITY MULTI

MITSUBISHI ELECTRIC CORPORATION

HEAD OFFICE : TOKYO BLDG., 2-7-3, MARUNOUCHI, CHIYODA-KU, TOKYO 100-8310, JAPAN

©Copyright 2007 MITSUBISHI ELECTRIC CORPORATION
Distributed in Dec. 2012 No. OCB413 REVISED EDITION-E
Distributed in Jul. 2012 No. OCB413 REVISED EDITION-D
Distributed in Aug. 2009 No. OCB413 REVISED EDITION-C PDF 6
Distributed in Feb. 2009 No. OCB413 REVISED EDITION-B PDF 6
Distributed in Oct. 2007 No. OCB413 REVISED EDITION-A PDF 7
Distributed in Mar. 2007 No. OCB413 PDF 7
Made in Japan

New publication, effective Dec. 2012
Specifications are subject to change without notice.