

# Air-Conditioners For Building Application INDOOR UNIT

## PLFY-P-VBM-E

For use with the R410A, R407C & R22    Uso del refrigerante R410A, R407C e R22  
Bei Verwendung von R410A, R407C & R22    Για χρήση με τα R410A, R407C και R22  
A utiliser avec le R410A, R407C et le R22    Para utilização com o R410A, R407C e o R22  
Bij gebruik van R410A, R407C & R22    R410A, R407C ve R22 ile beraber kullanmak için  
Para utilizar con el R410A, R407C y el R22    Для использования с моделями R410A, R407C и R22

### INSTALLATION MANUAL

For safe and correct use, read this manual and the outdoor unit installation manual thoroughly before installing the air-conditioner unit.

**FOR INSTALLER**

### INSTALLATIONSHANDBUCH

Aus Sicherheitsgründen und zur richtigen Anwendung vor Installation der Klimaanlage die vorliegende Bedienungsanleitung und das Installationshandbuch gründlich durchlesen.

**FÜR INSTALLATEURE**

### MANUEL D'INSTALLATION

Avant d'installer le climatiseur, lire attentivement ce manuel, ainsi que le manuel d'installation de l'appareil extérieur pour une utilisation sûre et correct.

**POUR L'INSTALLATEUR**

### INSTALLATIEHANDLEIDING

Lees deze handleiding en de installatiehandleiding van het buitenapparaat zorgvuldig door voordat u met het installeren van de airconditioner begint.

**VOOR DE INSTALLATEUR**

### MANUAL DE INSTALACIÓN

Para un uso seguro y correcto, lea detalladamente este manual de instalación antes de montar la unidad de aire acondicionado.

**PARA EL INSTALADOR**

### MANUALE DI INSTALLAZIONE

Per un uso sicuro e corretto, prima di installare il condizionatore d'aria leggere attentamente il presente manuale ed il manuale d'installazione dell'unità esterna.

**PER L'INSTALLATORE**

### ΕΓΧΕΙΡΙΔΙΟ ΟΔΗΓΙΩΝ ΕΓΚΑΤΑΣΤΑΣΗΣ

Για σωστή και ασφαλή χρήση, διαβάστε προσεκτικά αυτό το εγχειρίδιο, καθώς και το εγχειρίδιο εγκατάστασης της εξωτερικής μονάδας, πριν από την εγκατάσταση της μονάδας κλιματιστικού.

**ΓΙΑ ΑΥΤΟΝ ΠΟΥ ΚΑΝΕΙ ΤΗΝ ΕΓΚΑΤΑΣΤΑΣΗ**

### MANUAL DE INSTALAÇÃO

Para uma utilização segura e correcta, leia atentamente este manual e o manual de instalação da unidade exterior antes de instalar o aparelho de ar condicionado.

**PARA O INSTALADOR**

### MONTAJ ELKİTABI

Emniyetli ve doğru kullanım için, klima cihazını monte etmeden önce bu kılavuzu ve dış ünite montaj kılavuzunu tamamiyle okuyun.

**MONTÖR İÇİN**

### РУКОВОДСТВО ПО УСТАНОВКЕ

Для обеспечения безопасной и надлежащей эксплуатации внимательно прочтите данное руководство и руководство по установке наружного прибора перед установкой кондиционера.

**ДЛЯ УСТАНОВИТЕЛЯ****English (GB)****Deutsch (D)****Français (F)****Nederlands (NL)****Español (E)****Italiano (I)****Ελληνικά (GR)****Português (P)****Türkçe (TR)****Русский (RU)**

# Contents

1. Safety precautions.....	2	4. Electrical work .....	6
2. Installing the indoor unit .....	2	5. Installing the grille.....	11
3. Refrigerant pipe and drain pipe .....	4	6. Test run (Fig. 6-1).....	13

**Note:**  
The phrase “Wired remote controller” in this installation manual refers only to the PAR-21MAA.  
If you need any information for the other remote controller, please refer to either the installation manual or initial setting manual which are included in these boxes.

## 1. Safety precautions

- ▶ Before installing the unit, make sure you read all the “Safety precautions”.
- ▶ Please report to your supply authority or obtain their consent before connecting this equipment to the power supply system.

**⚠ Warning:**  
Describes precautions that must be observed to prevent danger of injury or death to the user.

**⚠ Caution:**  
Describes precautions that must be observed to prevent damage to the unit.

After installation work has been completed, explain the “Safety Precautions,” use, and maintenance of the unit to the customer according to the information in the Operation Manual and perform the test run to ensure normal operation. Both the Installation Manual and Operation Manual must be given to the user for keeping. These manuals must be passed on to subsequent users.

- ⊘ : Indicates an action that must be avoided.
- ⚠ : Indicates that important instructions must be followed.
- ⚡ : Indicates a part which must be grounded.
- ⚠ : Indicates that caution should be taken with rotating parts.
- ⚡ : Indicates that the main switch must be turned off before servicing.
- ⚡ : Beware of electric shock.
- ⚠ : Beware of hot surface.
- ⚡ ELV : At servicing, please shut down the power supply for both the Indoor and Outdoor Unit.

**⚠ Warning:**  
Carefully read the labels affixed to the main unit.

**⚠ Caution:**  
Appliances not accessible to the general public.  
Install the indoor unit at least 2.5 m above floor or grade level.

- ⚠ Warning:**
- Ask the dealer or an authorized technician to install the air conditioner.
  - The user should never attempt to repair the unit or transfer it to another location.
  - Install the unit at a place that can withstand its weight.
  - Use only specified cables for wiring. The wiring connections must be made securely with no tension applied on the terminal connections. Also, never splice the cables for wiring (unless otherwise indicated in this document). Failure to observe these instructions may result in overheating or a fire.
  - Use only accessories authorized by Mitsubishi Electric and ask the dealer or an authorized technician to install them.
  - Do not touch the heat exchanger fins.
  - Install the air conditioner according to this Installation Manual.
  - Have all electric work done by a licensed electrician according to local regulations.
  - The appliance shall be installed in accordance with national wiring regulations.

- If the air conditioner is installed in a small room, measures must be taken to prevent the refrigerant concentration from exceeding the safety limit even if the refrigerant should leak.
- If the supply cord is damaged, it must be replaced by the manufacturer, its service agent or similarly qualified persons in order to avoid a hazard.
- The cut face punched parts may cause injury by cut, etc. The installers are requested to wear protective equipment such as gloves, etc.
- When installing or relocating, or servicing the air conditioner, use only the specified refrigerant (R410A) to charge the refrigerant lines. Do not mix it with any other refrigerant and do not allow air to remain in the lines. If air is mixed with the refrigerant, then it can be the cause of abnormal high pressure in the refrigerant line, and may result in an explosion and other hazards.  
The use of any refrigerant other than that specified for the system will cause mechanical failure or system malfunction or unit breakdown. In the worst case, this could lead to a serious impediment to securing product safety.

- ⚠ Caution:**
- Do not use the existing refrigerant piping, when use R410A or R407C refrigerant.
  - Use ester oil, either oil or alkylbenzene (small amount) as the refrigerator oil to coat flares and flange connections, when use R410A or R407C refrigerant.
  - Do not use the air conditioner where food, pets, plants, precision instruments, or artwork are kept.
  - Do not use the air conditioner in special environments.

- Ground the unit.
- Install an leak circuit breaker, as required.
- Use power line cables of sufficient current carrying capacity and rating.
- Use only a circuit breaker and fuse of the specified capacity.
- Do not touch the switches with wet fingers.
- Do not touch the refrigerant pipes during and immediately after operation.
- Do not operate the air conditioner with the panels and guards removed.
- Do not turn off the power immediately after stopping operation.

## 2. Installing the indoor unit

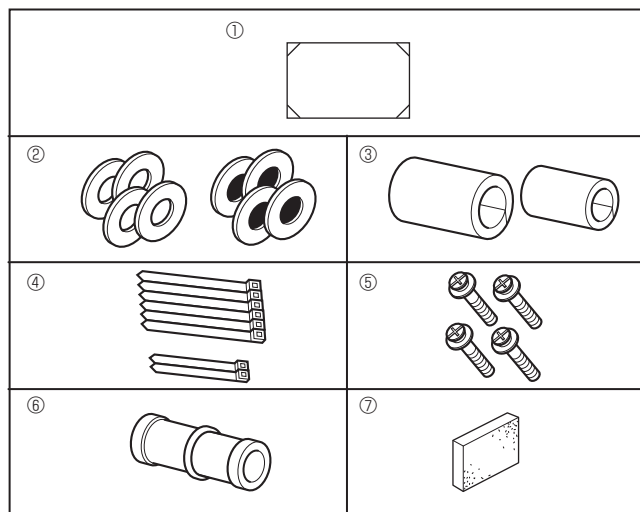

Fig. 2-1

### 2.1. Check the indoor unit accessories (Fig. 2-1)

The indoor unit should be supplied with the following accessories.

	Accessory name	Q'ty
①	Installation template	1
②	Washers (with insulation)	4
	Washers (without insulation)	4
③	Pipe cover (for refrigerant piping joint)	
	Small diameter	1
	Large diameter	1
④	Band (large)	6
	Band (small)	2
⑤	Screw with washer (M5 × 25) for mounting grille	4
⑥	Drain socket	1
⑦	Insulation	1

## 2. Installing the indoor unit

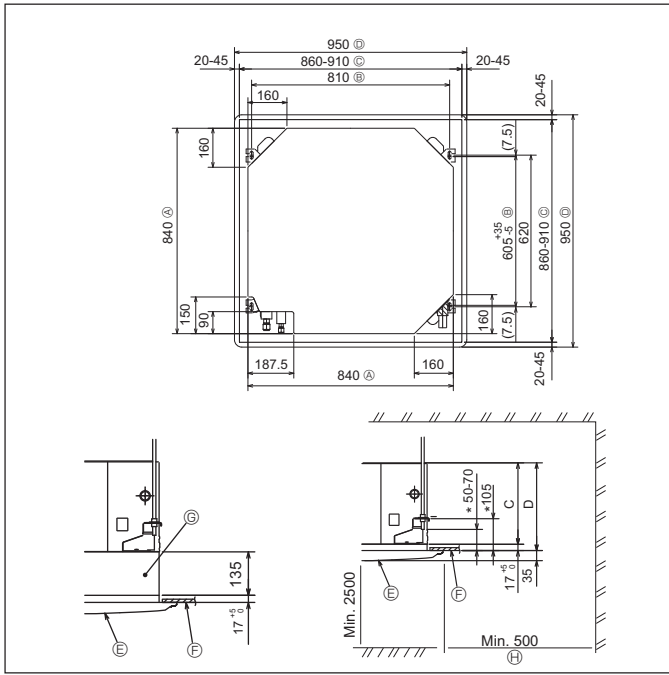

Fig. 2-2

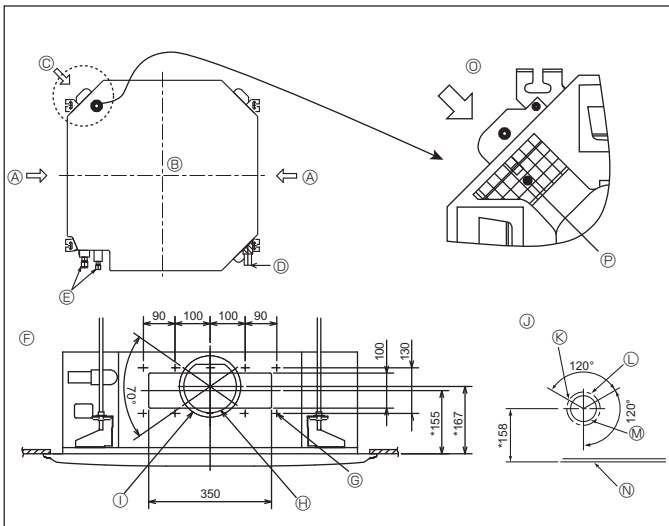

Fig. 2-3

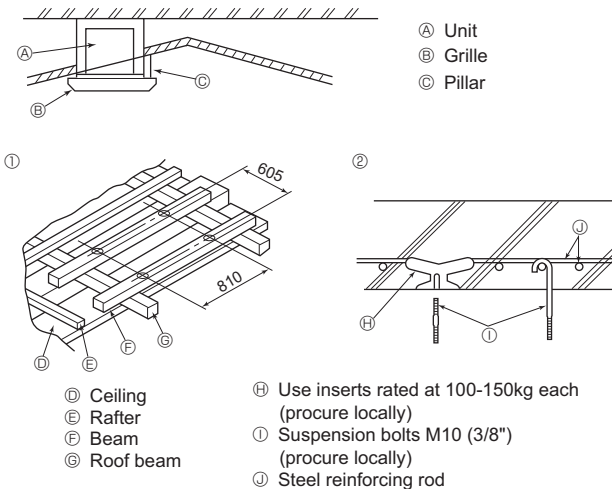

Fig. 2-4

## 2.2. Ceiling openings and suspension bolt installation locations (Fig. 2-2)

**Caution:**  
Install the indoor unit at least 2.5 m above floor or grade level.

- Using the installation template (top of the package) and the gauge (supplied as an accessory with the grille), make an opening in the ceiling so that the main unit can be installed as shown in the diagram. (The method for using the template and the gauge is shown.)
  - Before using, check the dimensions of template and gauge, because they change due to fluctuations of temperature and humidity.
  - The dimensions of ceiling opening can be regulated within the range shown in Fig. 2-2; so center the main unit against the opening of ceiling, ensuring that the respective opposite sides on all sides of the clearance between them becomes identical.
- Use M10 (3/8") suspension bolts.
  - Suspension bolts are to be procured at the field.
- Install securely, ensuring that there is no clearance between the ceiling panel & grille, and between the main unit & grille.
  - Outer side of main unit
  - Bolt pitch
  - Ceiling opening
  - Outer side of Grille
  - Grille
  - Ceiling
  - Multi function casement (option)
  - Entire periphery
- Note that the space between ceiling panel of the unit and ceiling slab and etc must be 10 to 15 mm.
- When the optional multi-functional casement is installed, add 135mm to the dimensions marked on the figure.

Models	C	D
32, 40, 50, 63, 80	241	258
100, 125	281	298

## 2.3. Branch duct hole and fresh air intake hole (Fig. 2-3)

At the time of installation, use the duct holes (cut out) located at the positions shown in Fig. 2-3, as and when required.

- A fresh air intake hole for the optional multi function casement can also be made.
- Note:**
  - The figure marked with \* in the drawing represent the dimensions of the main unit excluding those of the optional multi function casement.
  - When installing the optional multi function casement, add 135 mm to the dimensions marked on the figure.
  - When installing the branch ducts, be sure to insulate adequately. Otherwise condensation and dripping may occur.
  - When installing the fresh air intake hole, be sure to remove the insulator that is pasted on the indoor unit.
- Branch duct hole
- Indoor unit
- Fresh air intake hole
- Drain pipe
- Refrigerant pipe
- Branch duct hole diagram (view from either side)
- 14-ø2.8 burring hole
- ø175 burring hole pitch
- Fresh air intake hole diagram
- 3-ø2.8 burring hole
- ø125 burring hole pitch
- ø100 cut out hole
- Ceiling
- Detailed figure of removing the insulator
- Insulator
- ø150 cut out hole

## 2.4. Suspension structure (Give site of suspension strong structure) (Fig. 2-4)

- The ceiling work differs according to the construction of the building. Building constructors and interior decorators should be consulted for details.
- Extent of ceiling removal: The ceiling must be kept completely horizontal and the ceiling foundation (framework: wooden slats and slat holders) must be reinforced in order to protect the ceiling from vibration.
- Cut and remove the ceiling foundation.
- Reinforce the ends of the ceiling foundation where it has been cut and add ceiling foundation for securing the ends of the ceiling board.
- When installing the indoor unit on a slanted ceiling, attach a pillar between the ceiling and the grille and set so that the unit is installed horizontally.
- Wooden structures
  - Use tie beams (single storied houses) or second floor beams (two story houses) as reinforcing members.
  - Wooden beams for suspending air conditioners must be sturdy and their sides must be at least 6 cm long if the beams are separated by not more than 90 cm and their sides must be at least 9 cm long if the beams are separated by as much as 180 cm. The size of the suspension bolts should be ø10 (3/8"). (The bolts do not come with the unit.)
- Ferro-concrete structures
  - Secure the suspension bolts using the method shown, or use steel or wooden hangers, etc. to install the suspension bolts.

## 2. Installing the indoor unit

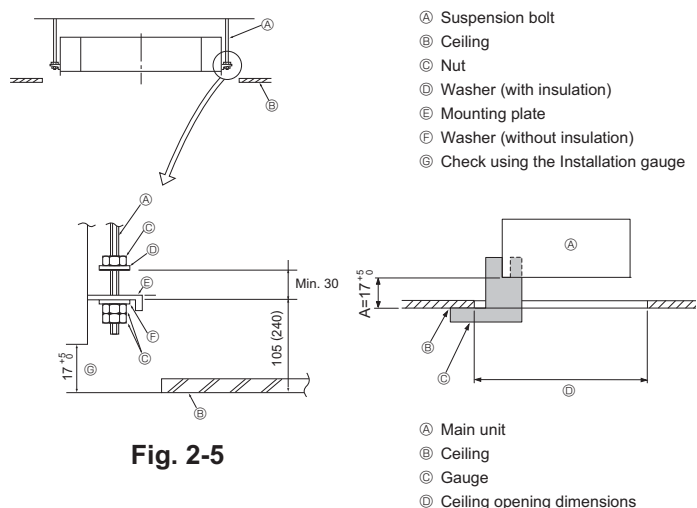

Fig. 2-5

Fig. 2-6

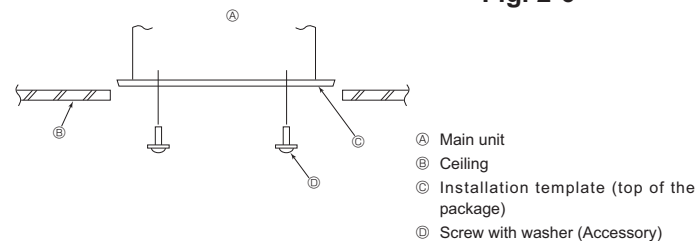

Fig. 2-7

## 3. Refrigerant pipe and drain pipe

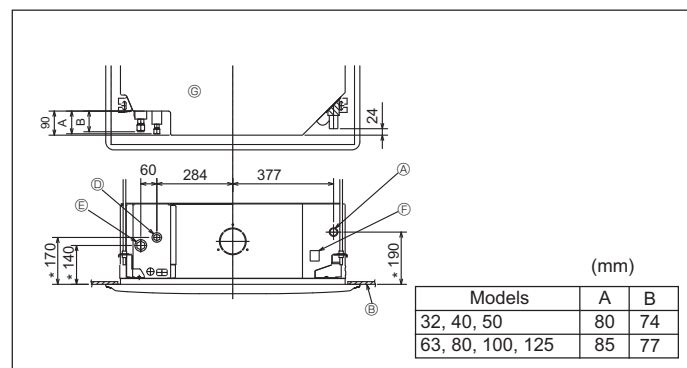

Fig. 3-1

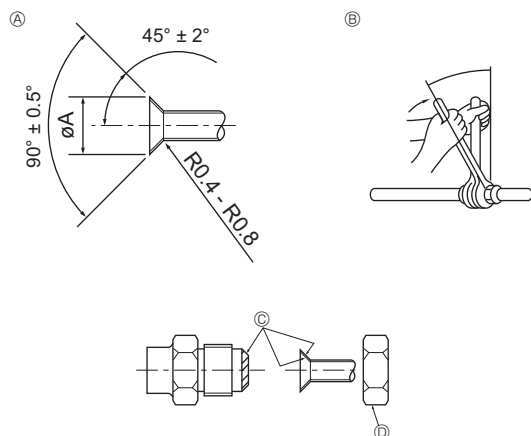

Fig. 3-2

### 2.5. Unit suspension procedures (Fig. 2-5)

Suspend the main unit as shown in the diagram.

Figures given in parentheses represent the dimensions in case of installing optional multi function casement.

- In advance, set the parts onto the suspension bolts in the order of the washers (with insulation), washers (without insulation) and nuts (double).
- Fit the washer with cushion so that the insulation faces downward.
- In case of using upper washers to suspend the main unit, the lower washers (with insulation) and nuts (double) are to be set later.
- Lift the unit to the proper height of the suspension bolts to insert the mounting plate between washers and then fasten it securely.
- When the main unit can not be aligned against the mounting hole on the ceiling, it is adjustable owing to a slot provided on the mounting plate.
- Make sure that A is performed within 17-22 mm. Damage could result by failing to adhere to this range. (Fig. 2-6)

#### ⚠ Caution:

Use the top half of the box as a protective cover to prevent dust or debris from getting inside the unit prior to installation of the decorative cover or when applying ceiling materials.

### 2.6. Confirming the position of main unit and tightening the suspension bolts (Fig. 2-7)

- Using the gauge attached to the grille, ensure that the bottom of the main unit is properly aligned with the opening of the ceiling. Be sure to confirm this, otherwise condensation may form and drip due to air leakage, etc.
- Confirm that the main unit is horizontally levelled, using a level or a vinyl tube filled with water.
- After checking the position of the main unit, tighten the nuts of the suspension bolts securely to fasten the main unit.
- The installation template (top of the package) can be used as a protective sheet to prevent dust from entering the main unit when the grilles are left unattached for a while or when the ceiling materials are to be lined after installation of the unit is finished.
- \* As for the details of fitting, refer to the instructions given on the Installation template.

### 3.1. Refrigerant and drainage piping locations of indoor unit

The figure marked with \* in the drawing represent the dimensions of the main unit excluding those of the optional multi function casement. (Fig. 3-1)

- Ⓐ Drain pipe
- Ⓑ Ceiling
- Ⓒ Grille
- Ⓓ Refrigerant pipe (liquid)
- Ⓔ Refrigerant pipe (gas)
- Ⓕ Water supply inlet
- Ⓖ Main unit

\* When the optional multi-functional casement is installed, add 135 mm to the dimensions marked on the figure.

### 3.2. Connecting pipes (Fig. 3-2)

- When commercially available copper pipes are used, wrap liquid and gas pipes with commercially available insulation materials (heat-resistant to 100 °C or more, thickness of 12 mm or more).
- The indoor parts of the drain pipe should be wrapped with polyethylene foam insulation materials (specific gravity of 0.03, thickness of 9 mm or more).
- Apply thin layer of refrigerant oil to pipe and joint seating surface before tightening flare nut.
- Use two wrenches to tighten piping connections.
- Use refrigerant piping insulation provided to insulate indoor unit connections. Insulate carefully.

#### Ⓐ Flare cutting dimensions

Copper pipe O.D. (mm)	Flare dimensions ⌀A dimensions (mm)
⌀6.35	8.7 - 9.1
⌀9.52	12.8 - 13.2
⌀12.7	16.2 - 16.6
⌀15.88	19.3 - 19.7
⌀19.05	22.9 - 23.3

#### ⚠ Warning:

When installing the unit, securely connect the refrigerant pipes before starting the compressor.

### 3. Refrigerant pipe and drain pipe

#### Ⓑ Refrigerant pipe sizes & Flare nut tightening torque

	R407C or R22				R410A				Flare nut O.D.	
	Liquid pipe		Gas pipe		Liquid pipe		Gas pipe		Liquid pipe (mm)	Gas pipe (mm)
	Pipe size (mm)	Tightening torque (N.m)	Pipe size (mm)	Tightening torque (N.m)	Pipe size (mm)	Tightening torque (N.m)	Pipe size (mm)	Tightening torque (N.m)		
P20/25/32/40	ODø6.35 (1/4")	14 - 18	ODø12.7 (1/2")	49 - 61	ODø6.35 (1/4")	14 - 18	ODø12.7 (1/2")	49 - 61	17	26
P50	ODø9.52 (3/8")	14 - 18*	ODø15.88 (5/8")	49 - 61*	ODø6.35 (1/4")	14 - 18	ODø12.7 (1/2")	49 - 61	17	26
P63/80	ODø9.52 (3/8")	34 - 42	ODø15.88 (5/8")	68 - 82	ODø9.52 (3/8")	34 - 42	ODø15.88 (5/8")	68 - 82	22	29
P100/125	ODø9.52 (3/8")	34 - 42	ODø19.05 (3/4")	68 - 82*	ODø9.52 (3/8")	34 - 42	ODø15.88 (5/8")	68 - 82	22	29

\* Connect the joint with the following pipes: Liquid and gas pipes of P50, gas pipe of P100/P125.

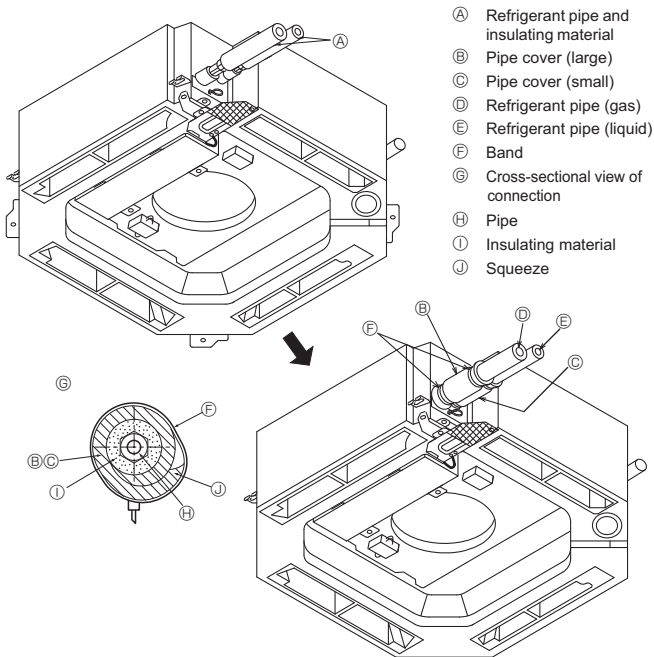

Fig. 3-3

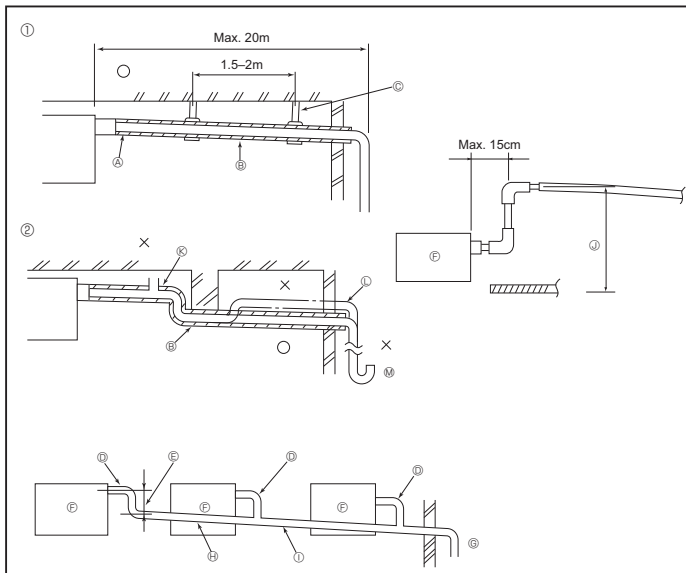

Fig. 3-4

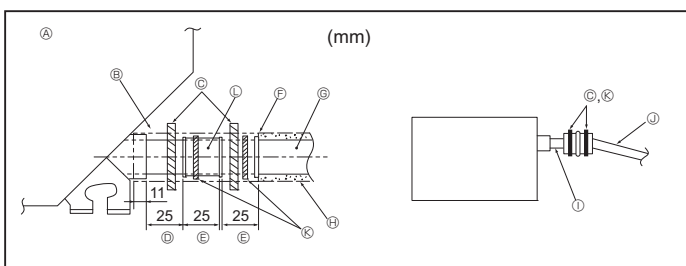

Fig. 3-5

- Ⓒ Apply refrigerating machine oil over the entire flare seat surface.
  - \* Do not apply refrigerating machine oil to the screw portions. (This will make the flare nuts more apt to loosen.)
- Ⓓ Be certain to use the flare nuts that are attached to the main unit. (Use of commercially-available products may result in cracking.)

### 3.3. Indoor unit (Fig. 3-3)

#### Heat insulation for refrigerant pipes:

- 1 Wrap the enclosed large-sized pipe cover around the gas pipe, making sure that the end of the pipe cover touches the side of the unit.
  - 2 Wrap the enclosed small-sized pipe cover around the liquid pipe, making sure that the end of the pipe cover touches the side of the unit.
  - 3 Secure both ends of each pipe cover with the enclosed bands. (Attach the bands 20 mm from the ends of the pipe cover.)
- After connecting the refrigerant piping to the indoor unit, be sure to test the pipe connections for gas leakage with nitrogen gas. (Check that there is no refrigerant leakage from the refrigerant piping to the indoor unit.)

### 3.4. Drainage piping work (Fig. 3-4)

- Use VP25 (O.D. ø32 (1-1/4") PVC TUBE) for drain piping and provide 1/100 or more downward slope.
- Be sure to connect the piping joints using a polyvinyl type adhesive.
- Observe the figure for piping work.
- Use the included drain hose to change the extraction direction.

- ① Correct piping
- ② Wrong piping
- Ⓐ Insulation (9 mm or more)
- Ⓑ Downward slope (1/100 or more)
- Ⓒ Support metal
- ⓧ Air bleeder
- Ⓘ Raised
- Ⓜ Odor trap

#### Grouped piping

- Ⓞ O. D. ø32 PVC TUBE
- Ⓟ Make it as large as possible
- Ⓠ Indoor unit
- Ⓡ Make the piping size large for grouped piping.
- Ⓢ Downward slope (1/100 or more)
- ① O. D. ø38 PVC TUBE for grouped piping. (9 mm or more insulation)
- Ⓣ Up to 85 cm

1. Connect the drain socket (supplied with the unit) to the drain port. (Fig. 3-5) (Fix the tube using PVC adhesive then secure it with a band.)
2. Install a locally purchased drain pipe (PVC pipe, O.D. ø32). (Fix the pipe using PVC adhesive then secure it with a band.)
3. Insulate the tube and pipe. (PVC pipe, O.D. ø32 and socket)
4. Check that drain flows smoothly.
5. Insulate the drain port with insulating material, then secure the material with a band. (Both insulating material and band are supplied with the unit.)

- Ⓐ Unit
- Ⓑ Insulating material
- Ⓒ Band (large)
- Ⓓ Drain port (transparent)
- Ⓔ Insertion margin
- Ⓕ Matching
- Ⓖ Drain pipe (O.D. ø32 PVC TUBE)
- Ⓗ Insulating material (purchased locally)
- ① Transparent PVC pipe
- Ⓣ O. D. ø32 PVC TUBE (Slope 1/100 or more)
- ⓧ Band (small)
- Ⓣ Drain socket



## 4. Electrical work

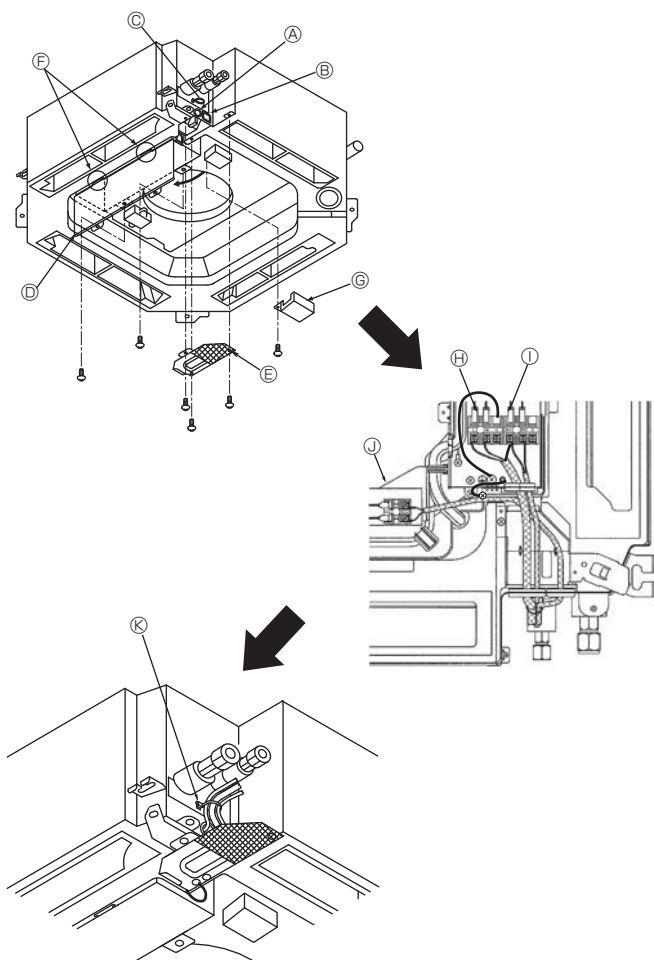

Fig. 4-1

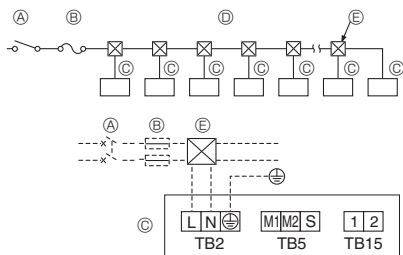

Fig. 4-2

### 4.1. Indoor unit (Fig. 4-1)

1. Remove the electrical wiring service panel.
  2. Remove the electrical box cover.
  3. Remove the MA Remote controller terminal cover.
  4. Wire the power cable and control cable separately through the respective wiring entries given in the diagram.
- Do not allow slackening of the terminal screws.
  - Leave excess cable so that the electrical box cover can be suspended below the unit during servicing. (Approx. 50 to 100 mm)
    - Ⓐ Entry for remote controller cable
    - Ⓑ Entry for power and control cable
    - Ⓒ Clamp
    - Ⓓ Electrical box cover
    - Ⓔ Service panel for electrical wiring
    - Ⓕ Temporary hook for electrical box cover
    - Ⓖ MA Remote controller terminal cover
    - Ⓗ Power supply terminals (with earth terminal) (L, N, ⊕)
    - Ⓘ Transmission terminals (M1, M2, S)
    - Ⓢ MA Remote controller terminal (1, 2)
    - Ⓚ Secure with the clamp

### 4.2. Power supply wiring

- Wiring size must comply with the applicable local and national code.
  - Install an earth longer than other cables.
  - Power supply codes of appliance shall not be lighter than design 60245 IEC 53 or 60227 IEC 53.
  - A switch with at least 3 mm contact separation in each pole shall be provided by the air conditioner installation.
- Power cable size : more than 1.5 mm<sup>2</sup>

#### ⚠ Warning:

**Never splice the power cable or the indoor-outdoor connection cable, otherwise it may result in a smoke, a fire or communication failure.**

#### ► Use earth leakage breaker (NV).

For breaker, means shall be provided to ensure disconnection of all active phase conductors of the supply.

[Fig. 4-2]

- Ⓐ Switch 16 A
- Ⓑ Overcurrent protection 16 A
- Ⓒ Indoor unit
- Ⓓ Total operating current be less than 16 A
- Ⓔ Pull box

### 4.3. Types of control cables

#### 1. Wiring transmission cables

Types of transmission cable	Shielding wire CVVS or CPEVS
Cable diameter	More than 1.25 mm <sup>2</sup>
Length	Less than 200 m

#### 2. M-NET Remote control cables

Types of remote control cable	Shielding wire MVVS
Cable diameter	0.5 to 1.25 mm <sup>2</sup>
Length	Add any portion in excess of 10 m to within the longest allowable transmission cable length 200 m

#### 3. MA Remote control cables

Types of remote control cable	2-core cable (unshielded)
Cable diameter	0.3 to 1.25 mm <sup>2</sup>
Length	Less than 200 m

## 4. Electrical work

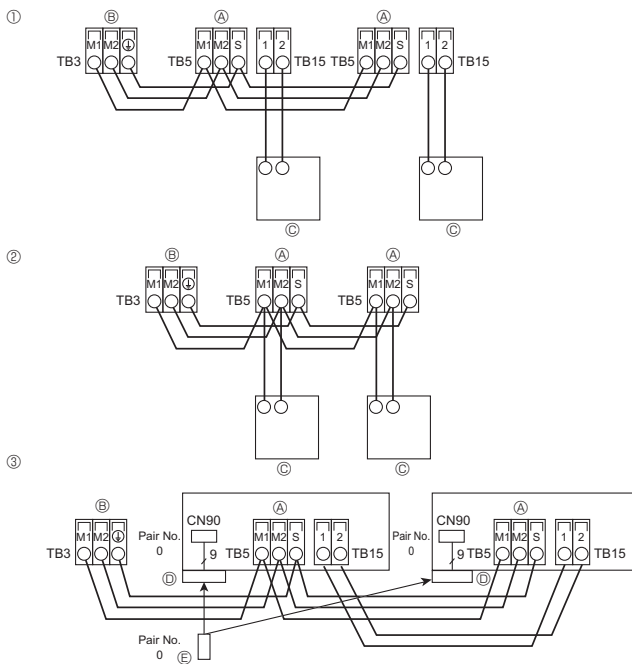

Fig. 4-3

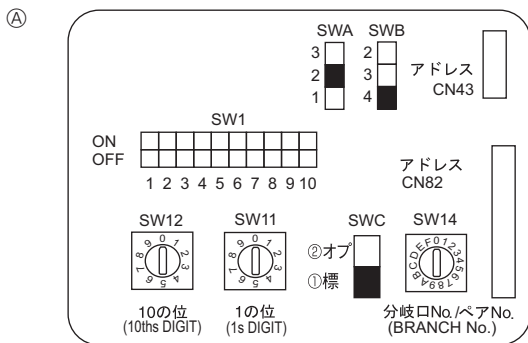

Fig. 4-4

### 4.6. Switch setting for high ceiling or at the time of changing the number of air outlets (Fig. 4-4)

With this unit, the air flow rate and fan speed can be adjusted by setting the SWA and SWB (slide switch). Select a suitable setting from the table below according to the installation location.

\* Make sure the SWA and SWB switch are set, otherwise problems such as not getting cool/warm may occur.

#### ■ PLFY-P32-P80VBM

SWB	SWA	①	②	③
		Silent	Standard	High ceiling
④	4 direction	2.5 m	2.7 m	3.5 m
③	3 direction	2.7 m	3.0 m	3.5 m
②	2 direction	3.0 m	3.3 m	3.5 m

#### ■ PLFY-P100,P125VBM

SWB	SWA	①	②	③
		Silent	Standard	High ceiling
④	4 direction	2.7 m	3.2 m	4.5 m
③	3 direction	3.0 m	3.6 m	4.5 m
②	2 direction	3.3 m	4.0 m	4.5 m

### 4.7. Sensing room temperature with the built-in sensor in a remote controller (Fig. 4-4)

If you want to sense room temperature with the built-in sensor in a remote controller, set SW1-1 on the control board to "ON". The setting of SW1-7 and SW1-8 as necessary also makes it possible to adjust the airflow at a time when the heating thermometer is OFF.

### 4.4. Connecting remote controller, indoor and outdoor transmission cables (Fig. 4-3)

• Connect indoor unit TB5 and outdoor unit TB3. (Non-polarized 2-wire)  
The "S" on indoor unit TB5 is a shielding wire connection. For specifications about the connecting cables, refer to the outdoor unit installation manual.

• Install a remote controller following the manual supplied with the remote controller.

• Connect the remote controller's transmission cable within 10 m using a 0.75 mm<sup>2</sup> core cable. If the distance is more than 10 m, use a 1.25 mm<sup>2</sup> junction cable.

#### ① MA Remote controller

• Connect the "1" and "2" on indoor unit TB15 to a MA remote controller. (Non-polarized 2-wire)

• DC 9 to 13 V between 1 and 2 (MA remote controller)

#### ② M-NET Remote controller

• Connect the "M1" and "M2" on indoor unit TB5 to a M-NET remote controller. (Non-polarized 2-wire)

• DC 24 to 30 V between M1 and M2 (M-NET remote controller)

#### ③ Wireless remote controller (When installing wireless signal receiver)

• Connect the wire of wireless signal receiver (9-pole cable) to CN90 of indoor controller board.

• When more than two units are run under group control using wireless remote controller, connect TB15 each with the same number.

• To change Pair No. setting, refer to installation manual attached to wireless remote controller. (In initial setting of indoor unit and wireless remote controller, Pair No. is 0.)

Ⓐ Terminal block for indoor transmission cable

Ⓑ Terminal block for outdoor transmission cable (M1(A), M2(B), ⊕(S))

Ⓒ Remote controller

Ⓓ wireless signal receiver

Ⓔ wireless remote controller

### 4.5. Setting addresses (Fig. 4-4)

(Be sure to operate with the main power turned OFF.)

• There are 2 types of rotary switch setting available: setting addresses 1 to 9 and over 10, and setting branch numbers.

#### ① How to set addresses

Example: If Address is "3", remain SW12 (for over 10) at "0", and match SW11 (for 1 to 9) with "3".

#### ② How to set branch numbers SW14 (Series R2 only)

Match the indoor unit's refrigerant pipe with the BC controller's end connection number.

Remain other than series R2 at "0".

• The rotary switches are all set to "0" when shipped from the factory. These switches can be used to set unit addresses and branch numbers at will.

• The determination of indoor unit addresses varies with the system at site. Set them referring to the Data Book.

Ⓐ Address board

## 4. Electrical work

### 4.8. How to set the fixed up/down air direction (Only for wired remote controller)

- For PLFY-BM, only the particular outlet can be fixed to certain direction with the procedures below. Once fixed, only the set outlet is fixed every time air conditioner is turned on. (Other outlets follow UP/DOWN air direction setting of the remote controller.)

#### ■ Explanation of word

- "Address No. of indoor unit" is the number given to each air conditioner.
- "Outlet No." is the number given to each outlet of air conditioner. (Refer to the right.)
- "Up/Down air direction" is the direction (angle) to fix.

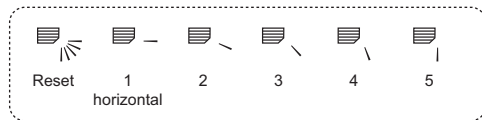

#### Remote controller setting

The airflow direction of this outlet is controlled by the airflow direction setting of remote controller.

#### Fixed setting

The airflow direction of this outlet is fixed in particular direction.

\* When it is cold because of direct airflow, the airflow direction can be fixed horizontally to avoid direct airflow.

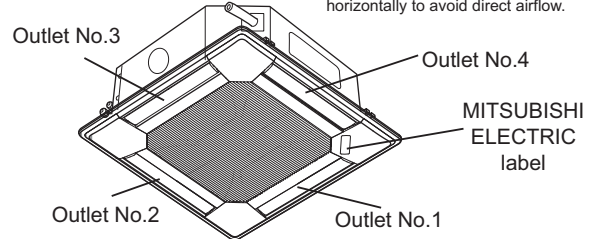

Note: "0" indicates all outlets.

### Operation buttons (During the fixed airflow direction mode)

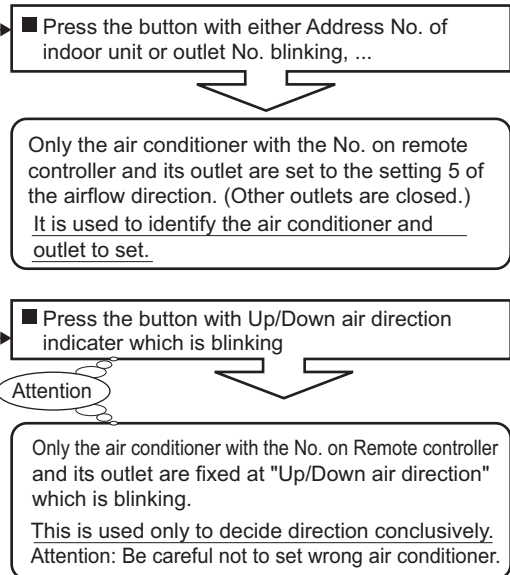
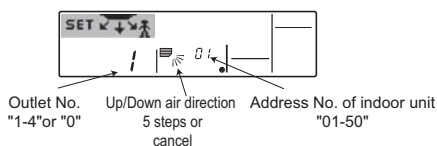
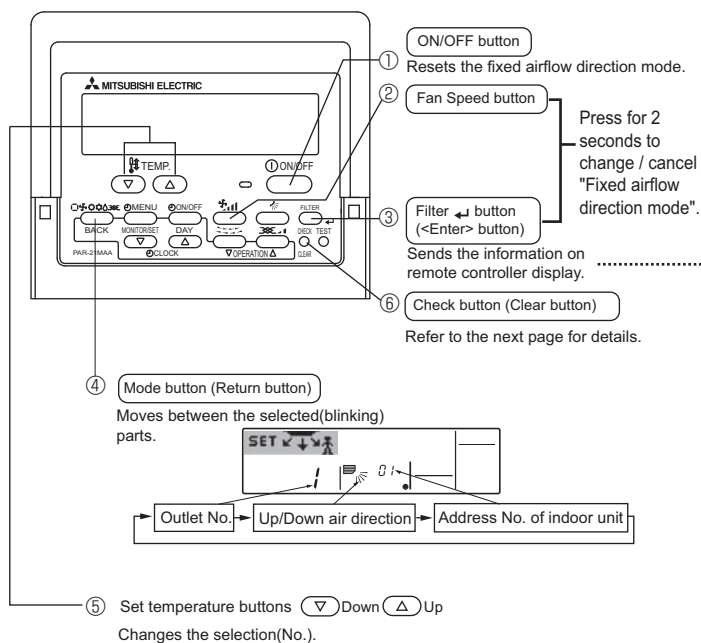



## 4. Electrical work

### < Process for setting >

#### [1] To turn off air conditioner and change the remote controller to "Fixed airflow direction mode"

1. Press ON/OFF button ① to turn off the air conditioner.
2. Press Fan Speed button ② and Filter button ③ for more than 2 seconds simultaneously and it becomes the fixed airflow direction mode after a while.

"Fixed airflow direction mode" display



※ Air blows downward after it becomes "fixed airflow direction mode"

#### [2] To select and identify the outlet to set

1. Press Set Temperature button ⑤ to change number with the outlet No. blinking. Select outlet No. to set.

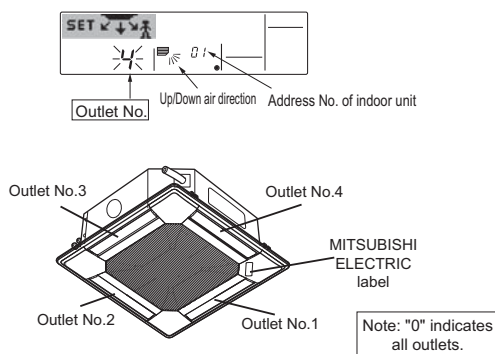

2. Press Filter button ③ to send the information on remote controller.
3. Wait for 15 seconds . How does the air conditioner run?
  - Only the air from the selected outlet blows downward.
    - Go to step[3].
  - Air from the wrong outlet blows downward.
    - Repeat 1 and set again.
  - All outlets are closed.
    - The number of the air conditioner (Address No. of indoor unit) is wrong. Refer to How to find air conditioner No..

#### [3] To fix air direction

1. Press Mode button (Return button) ④ to blink Up/Down air direction indicator.
2. Press Set Temperature button ⑤ until the direction to set is chosen.
3. Press Filter button ③ to send the information on remote controller to air conditioner.
4. Wait for 15 seconds . How does the air conditioner run?
  - Airflow direction is set in the selected direction.
    - The fixed setting completed (Go to step [4].)
  - Airflow direction is set in the wrong direction.
    - Repeat 2. and set again.

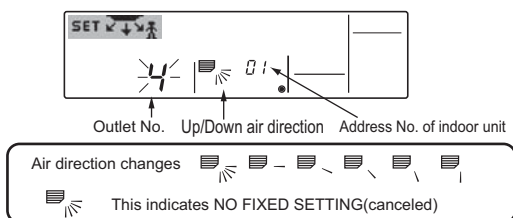

#### [4] To cancel "Fixed airflow direction mode"

1. Press ON/OFF button ① to cancel "Fixed airflow direction mode". It is also canceled by pressing Fan Speed button ② and Filter button ③ for more than 2 seconds simultaneously.
2. Do not operate remote controller for 30 seconds after the "Fixed airflow direction mode" is canceled. It does not accept even if it is operated.

## 4. Electrical work

### ■ How to find air conditioner No.

- Each air conditioner has its own Address No. of indoor unit (Example below).
  - Address No. of indoor unit can be set ranging from "01" to "50".
  - To find air conditioner No. to set, refer to the procedures below.
- Air conditioner No. is found by its airflow direction with Address No. of indoor unit changed one after the other.

Example) Structure of the system

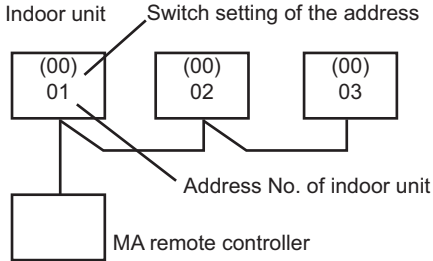

When the Switch setting of the address is "00", address No. of indoor unit is given automatically.

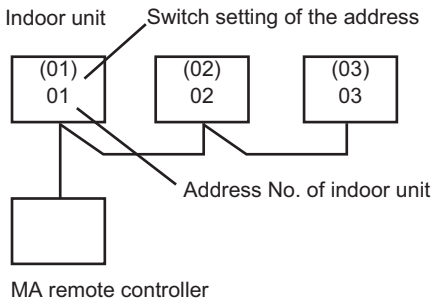

When the Switch setting of the address is not "00", switch setting of the address is also address No. of indoor unit.

### <Process to find air conditioner No.>

#### [1] To check Address No. of indoor unit

1. Press Mode button (Return button) ④ and Address No. of indoor unit blinks.  
Adjust address No. of indoor unit to "01" with Set Temperature button ⑤.

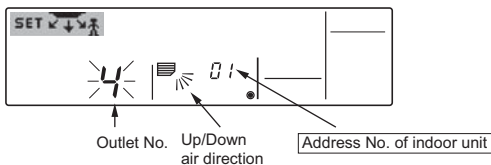

2. Press Filter ③ button to send the information on remote controller.
3. Wait for 15 seconds. How does the air conditioner run?
  - Only air from the outlet which No. displayed on remote controller blows downward.
  - Address No.01 of indoor unit is the air conditioner No..
- All outlets are closed.
- Go to step [2].

#### [2] To check by changing Address No. of indoor unit. one after the other (Maximum unit No. is 50)

1. Press Mode button (Return button) ④ and Address No. of indoor unit blinks.

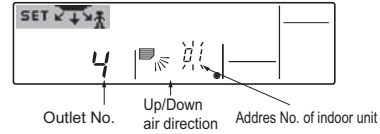

Adjust to the next address No. with Set Temperature button ⑤.

2. Press Filter ③ button to send the information on remote controller.
3. Wait for 15 seconds after sending. How does the air conditioner run?
  - Only the outlet which No. displayed on remote controller blows downward.
  - No. displayed in remote controller is air conditioner No. (Checking completed)
  - All outlets are closed.
  - Repeat [1] and continue this procedure.
  - "Err" is displayed on remote controller.
  - This group does not have this address No. of indoor unit. (Go back to [1] and continue.)



#### To clear fixed setting

To clear all fixed setting (reset to initial setting), press check button (clear button) ⑥ for more than 3 seconds in fixed airflow direction mode. Display of remote controller blinks and the set information is cleared.

#### Note:

**This operation clears the fixed setting information of all air conditioner connected to the remote controller.**

## 5. Installing the grille

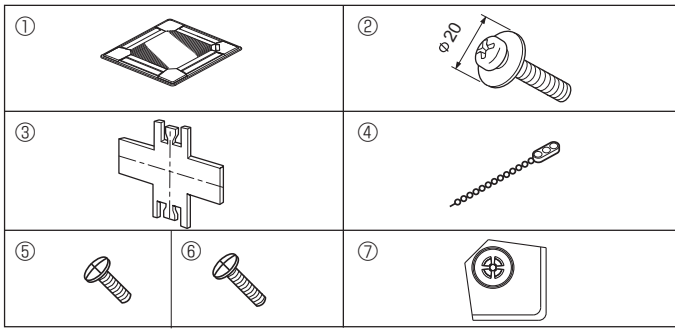

Fig. 5-1

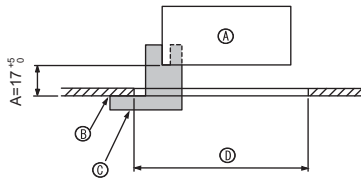

Fig. 5-2

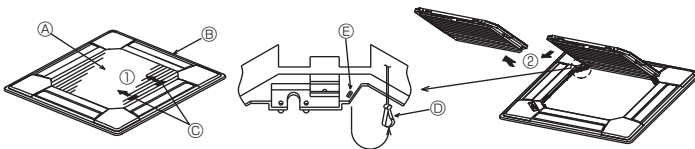

Fig. 5-3

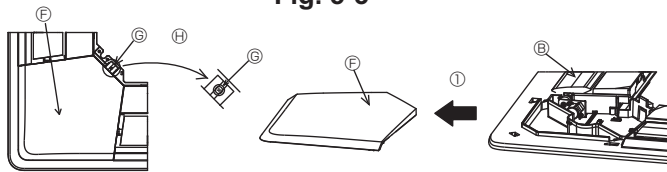

Fig. 5-4

	4-directional	3-directional
Blowout direction patterns	1 pattern: Initial setting 	4 patterns: 1 air outlet fully closed 
	2-directional	
Blowout direction patterns	6 patterns: 2 air outlet fully closed 	

Table 1



Fig. 5-5

### 5.1. Checking the contents (Fig. 5-1)

- This kit contains this manual and the following parts.

	Accessory name	Q'ty	Remark
①	Grille	1	950 × 950 (mm)
②	Screw with captive washer	4	M5 × 0.8 × 25
③	Gauge	1	(Divided into four parts)
④	Fastener	3	
⑤	Screw	4	4 × 8
⑥	Screw	1	4 × 12
⑦	i-see sensor corner panel	1	for PLP-6BAE

### 5.2. Preparing to attach the grille (Fig. 5-2)

- With the gauge ③ supplied with this kit, adjust and check the positioning of the unit relative to the ceiling. If the unit is not properly positioned relative to the ceiling, it may allow air leaks or cause condensation to collect.
- Make sure that the opening in the ceiling is within the following tolerances: 860 × 860 - 910 × 910
- Make sure that A is performed within 17-22 mm. Damage could result by failing to adhere to this range.
  - Ⓐ Main unit
  - Ⓑ Ceiling
  - Ⓒ Gauge ③ (inserted into the unit)
  - Ⓓ Ceiling opening dimensions

#### 5.2.1. Removing the intake grille (Fig. 5-3)

- Slide the levers in the direction indicated by the arrow ① to open the intake grille.
- Unlatch the hook that secures the grille.
  - \* Do not unlatch the hook for the intake grille.
- With the intake grille in the "open" position, remove the hinge of the intake grille from the grille as indicated by the arrow ②.

#### 5.2.2. Removing the corner panel (Fig. 5-4)

- Remove the screw from the corner of the corner panel. Slide the corner panel as indicated by the arrow ① to remove the corner panel.

#### [Fig. 5-3, 5-4]

- Ⓐ Intake grille
- Ⓑ Grille
- Ⓒ Intake grille levers
- Ⓓ Grille hook
- Ⓔ Hole for the grille's hook
- Ⓕ Corner panel
- Ⓖ Screw
- Ⓗ Detail

### 5.3. Selection of the air outlets

For this grille the discharge direction is available in 11 patterns. Also, by setting the remote controller to the appropriate settings, you can adjust the airflow and speed. Select the required settings from the Table 1 according to the location in which you want to install the unit.

- Decide on the discharge direction pattern.
- Be sure to set the remote controller to the appropriate settings, according to the number of air outlets and the height of the ceiling on which the unit will be installed.

#### Note:

For 3- and 2-directional, please use the air outlet shutter plate (option).

### 5.4. Installing the grille

#### 5.4.1. Preparations (Fig. 5-5)

- Install the 2 enclosed screws with washer ② in the main unit (at the corner drain pipe area and at the opposite corner) as shown in the diagram.

## 5. Installing the grille

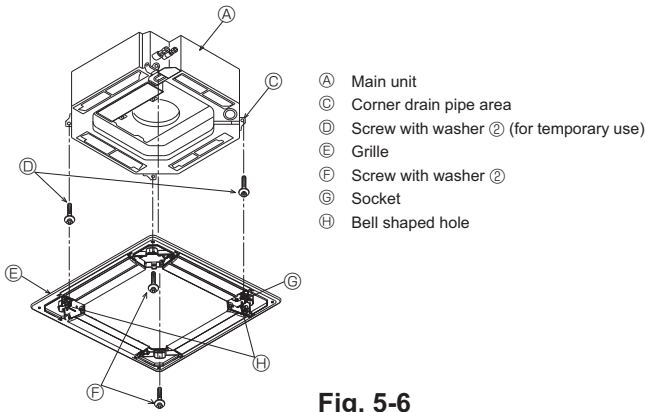

- (A) Main unit
- (C) Corner drain pipe area
- (D) Screw with washer ② (for temporary use)
- (E) Grille
- (F) Screw with washer ②
- (G) Socket
- (H) Bell shaped hole

Fig. 5-6

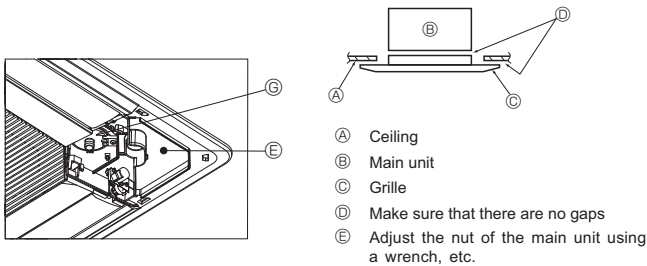

- (A) Ceiling
- (B) Main unit
- (C) Grille
- (D) Make sure that there are no gaps
- (E) Adjust the nut of the main unit using a wrench, etc.

Fig. 5-7

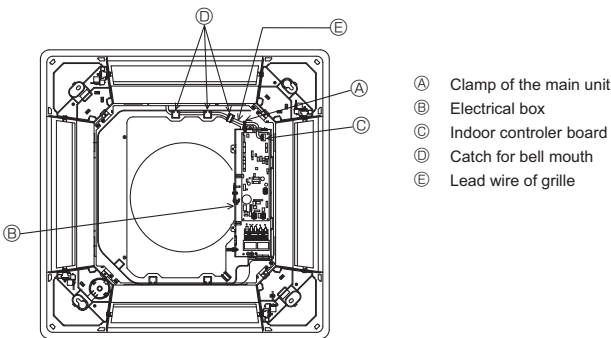

- (A) Clamp of the main unit
- (B) Electrical box
- (C) Indoor controller board
- (D) Catch for bell mouth
- (E) Lead wire of grille

Fig. 5-8

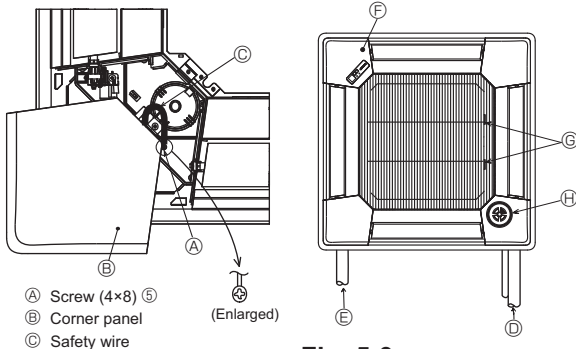

- (A) Screw (4x8) ⑤
- (B) Corner panel
- (C) Safety wire

Fig. 5-9

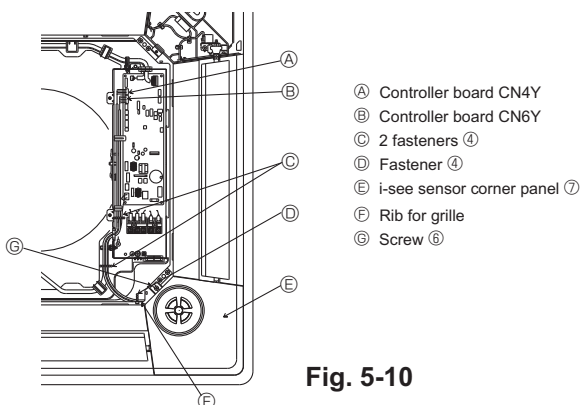

- (A) Controller board CN4Y
- (B) Controller board CN6Y
- (C) 2 fasteners ①
- (D) Fastener ④
- (E) i-see sensor corner panel ⑦
- (F) Rib for grille
- (G) Screw ⑥

Fig. 5-10

### 5.4.2. Temporary installation of the grille (Fig. 5-6)

- Temporarily secure the grille using the bell shaped holes by putting the socket of the grille marked ③ on the corner drain pipe area of the main unit.
  - \* Make sure that the lead wiring of the grille does not get pinched between the grille and the main unit.

### 5.4.3. Securing the grille (Fig. 5-7)

- Secure the grille to the main unit by tightening the previously installed 2 screws (with captive washer) as well as the 2 remaining screws (with captive washer).
  - \* Make sure that there are no gaps between the main unit and the grille or the grille and the ceiling.

### Fixing gaps between the grille and the ceiling

With the grille attached, adjust the height of the main unit to close the gap.

#### ⚠ Caution:

**When tightening the screw with captive washer ②, tighten it at a torque of 4.8 N·m or less. Never use an impact screwdriver.**

- It may result in parts damage.

### 5.4.4. Wire connection (Fig. 5-8)

- Remove the 2 screws fixing the cover of electrical branch box of the unit and open the cover.
  - Be sure to connect the connector (white, 20-pole) for vane motor of the grille to CNV connector of controller board of the unit.
- The lead wire of grille is passed through the catch for bell mouth of the unit perfectly. The remaining lead wire is tied with clamp of the unit and put the cover of the unit again with 2 screws.

#### Note:

**Do not put the remaining lead wire in electrical branch box of the unit.**

## 5.5. Installing the intake grille (Fig. 5-9)

#### Note:

**When reinstalling the corner panels (each with a safety wire attached), connect the other end of each safety wire to the grille using a screw (4 pcs, 4 × 8) as shown in the illustration.**

- \* If the corner panels are not attached, they may fall off while the unit is operating.
- Perform the procedure that is described in "5.2. Preparing to attach the grille" in reverse order to install the intake grille and the corner panel.
- Multiple units can be installed with grille so that the position of the logo on each corner panel is consistent with the other units regardless of the orientation of the intake grille. Align the logo on the panel according to the wishes of the customer as shown in the diagram to the left. (The position of the grille can be changed.)
  - Ⓧ Refrigerant piping of the main unit
  - Ⓨ Drain piping of the main unit
  - Ⓩ Initial position of the corner panel (logo attached)
- \* Installation in any position is possible.
- Ⓩ Initial position of the levers on the intake grille
- \* Although the clips can be installed in any of 4 positions, the configuration shown here is recommended. (It is not necessary to remove the intake grille when maintenance is performed on the electric component box of the main unit.)
- Ⓢ i-see sensor (PLP-6BAE panel)

## 5.6. Installation of i-see sensor corner panel (Fig. 5-10)

For PLP-6BAE panel

- Take the lead wires CN4Y (white) and CN6Y (red) of the i-see sensor corner panel ⑦ from the side of the electrical box on the unit and make sure to connect them to the connector of the controller board.
- Lead wires of the i-see sensor corner panel ⑦ should be fixed at the rib of the grille with the fastener ④ so that there is no slack.
- Lead wires should be held together with the lead wires of the unit and fixed with 2 of the fastener ④ so that there is no slack.
- Put the cover back on the electrical box with 3 screws.
- \* Make sure wires are not caught in the cover of electric box. If they are caught, they will be cut.
- Adverse procedure of "5.2. Preparing to attach the grille" will be taken for installing the i-see sensor corner panel.
- \* The i-see sensor corner panel should be fixed onto the grille ① with screw ⑥.

## 5. Installing the grille

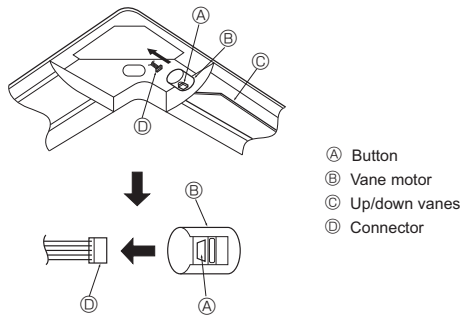

Fig. 5-11

### 5.7. Locking the up/down airflow direction (Fig. 5-11)

The vanes of the unit can be set and locked in up or down orientations depending upon the environment of use.

- Set according to the preference of the customer.

The operation of the fixed up/down vanes and all automatic controls cannot be performed using the remote controller. In addition, the actual position of the vanes may differ from the position indicated on the remote controller.

- ① Turn off the main power switch.  
Injuries or an electrical shock may occur while the fan of the unit is rotating.
- ② Disconnect the connector for the vane motor of the vent that you want to lock. (While pressing the button, remove the connector in the direction indicated by the arrow as shown in the diagram.) After removing the connector, insulate it with tape.

It also can be set by remote controller. Refer to 4.7.

### 5.8. Check

- Make sure that there is no gap between the unit and the grille, or between the grille and the surface of the ceiling. If there is any gap between the unit and the grille, or between the grille and the surface of the ceiling, it may cause dew to collect.
- Make sure that the wires have been securely connected.
- For PLP-6BAE, check the rotating movement of the i-see sensor. If the i-see sensor does not rotate, review the procedure in "5.6. Installation of i-see sensor corner panel".

## 6. Test run (Fig. 6-1)

### 6.1. Before test run

- ▶ After completing installation and the wiring and piping of the indoor and outdoor units, check for refrigerant leakage, looseness in the power supply or control wiring, wrong polarity, and no disconnection of 1 phase in the supply.
- ▶ Use a 500-volt megohmmeter to check that the resistance between the power supply terminals and ground is at least 1.0 MΩ.

- ▶ Do not carry out this test on the control wiring (low voltage circuit) terminals.

⚠ Warning:

Do not use the air conditioner if the insulation resistance is less than 1.0 MΩ.

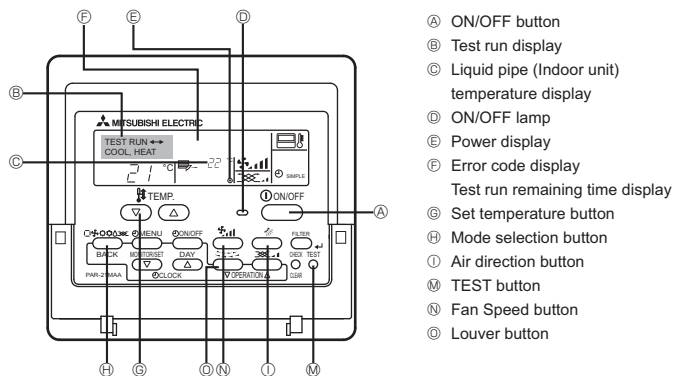

Fig. 6-1

### 6.2. Test run

#### Using wired remote controller (Fig. 6-1)

- ① Turn on the power at least 12 hours before the test run.
- ② Press the [TEST] button twice. ➡ "TEST RUN" liquid crystal display
- ③ Press the [Mode selection] button and switch to the cooling (or heating) mode.  
➡ Make sure that cold (or warm) wind is blown out.
- ④ Press the [Fan speed] button. ➡ Make sure that the wind speed is switched.
- ⑤ Press the [Air direction button] or [Louver button].  
➡ Check operation of the vane or louver.
- ⑥ Check operation of the outdoor unit fan.
- ⑦ Release test run by pressing the [ON/OFF] button. ➡ Stop
- ⑧ Register a telephone number.

The telephone number of the repair shop, sales office, etc., to contact if an error occurs can be registered in the remote controller. The telephone number will be displayed when an error occurs. For registration procedures, refer to the operation manual for the indoor unit.

#### Note:

- If an error code is displayed on the remote controller or if the air conditioner does not operate properly, refer to the outdoor unit installation manual or other technical materials.
- The OFF timer is set for the test run to automatically stop after 2 hours.
- During the test run, the time remaining is shown in the time display.
- During the test run, the temperature of the indoor unit refrigerant pipes is shown in the room temperature display of the remote controller.
- When the VANE or LOUVER button is pressed, the message "NOT AVAILABLE" may appear on the remote controller display depending on the indoor unit model, but this is not a malfunction.

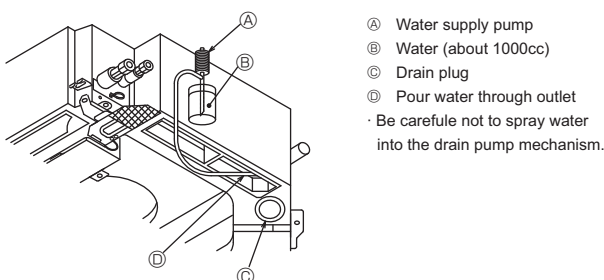

Fig. 6-2

### 6.3. Check of drainage (Fig. 6-2)

- Ensure that the water is being properly drained out and that no water is leaking from joints.

#### When electric work is completed.

- Pour water during cooling operation and check.

#### When electric work is not completed.

- Pour water during emergency operation and check.

\* Drain pan and fan are activated simultaneously when single phase 220-240V is turned on to L and N on terminal block after the connector (SWE) on controller board in the electrical branch box is set to ON.

Be sure to turn it back to the former state after work.

---

This product is designed and intended for use in the residential,  
commercial and light-industrial environment.

The product at hand is based on the following EU regulations:

- Low Voltage Directive 2006/95/EC
- Electromagnetic Compatibility Directive 2004/108/EC
- Machinery Directive 2006/42/EC
- Energy-related Products Directive 2009/125/EC \*
- \* Only P32/40/50/63/80/100
- RoHs Directive 2011/65/EU

Please be sure to put the contact address/telephone number on  
this manual before handing it to the customer.

**mitsubishi** **ELECTRIC CORPORATION**

HEAD OFFICE: TOKYO BLDG., 2-7-3, MARUNOUCHI, CHIYODA-KU, TOKYO 100-8310, JAPAN