

PARTS CATALOG

Series PLA Ceiling Cassettes R410A

Indoor unit
[Model names] [Service Ref.]

PLA-ZRP35BA	PLA-ZRP35BA.UK
PLA-ZRP50BA	PLA-ZRP50BA.UK
PLA-ZRP60BA	PLA-ZRP60BA.UK
PLA-ZRP71BA	PLA-ZRP71BA.UK
PLA-ZRP125BA	PLA-ZRP125BA.UK
PLA-ZRP140BA	PLA-ZRP140BA.UK

NOTE:
• RoHS compliant products
have <G> mark on the
spec name plate.

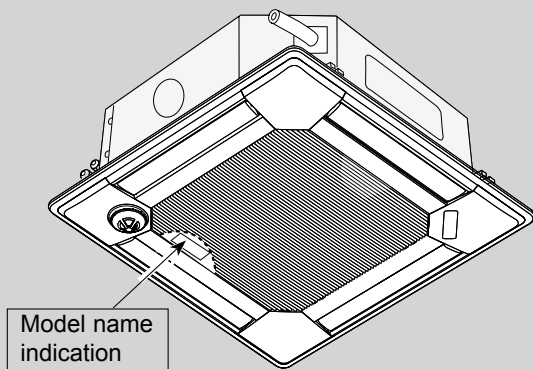

INDOOR UNIT

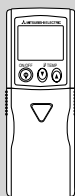

WIRELESS REMOTE
CONTROLLER

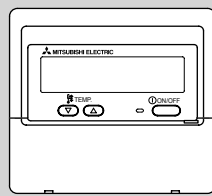

WIRED REMOTE
CONTROLLER

CONTENTS

1. RoHS PARTS LIST..... 2

SERVICE MANUAL (OCH535)

PANEL PARTS

PLP-6BAE (i-see sensor)

PLP-6BALME (i-see sensor with wireless remote controller)

PLP-6BAMDE (i-see sensor with wired remote controller)

PLP-6BAJ (Auto descending panel)

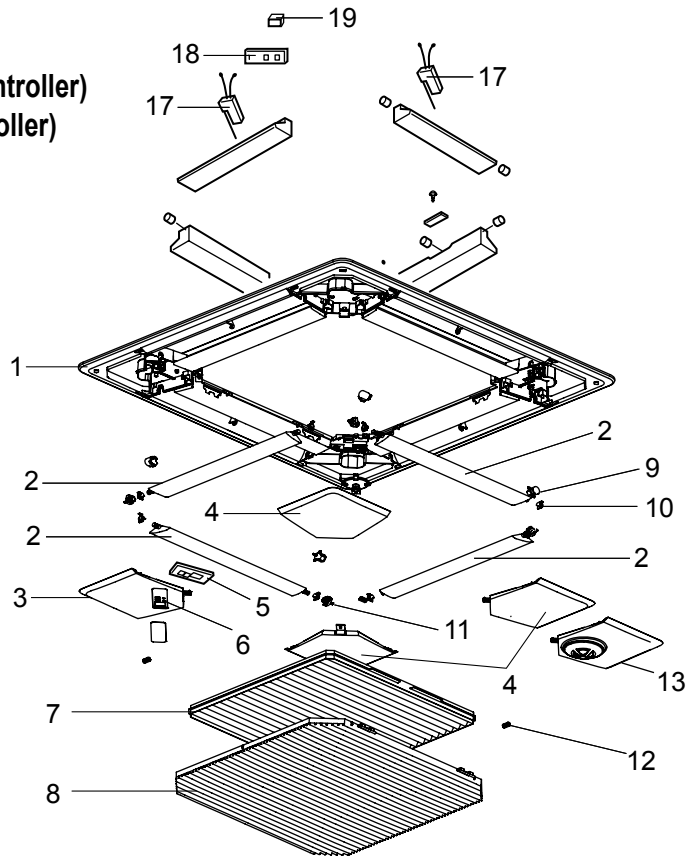
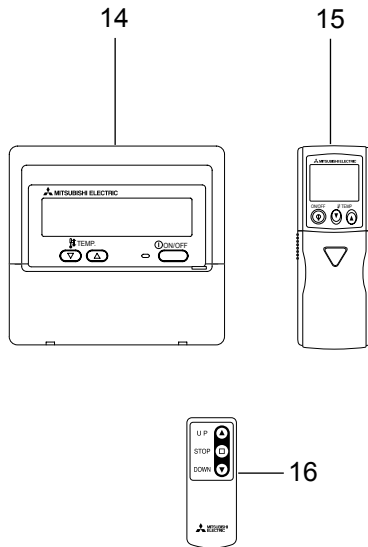

Part numbers that are circled are not shown in the illustration.

No.	RoHS	Part No.	Part Name	Specification	Q'ty/unit				Remarks (Drawing No.)	Wiring Diagram Symbol
					PLP-6					
					BAE	BALME	BAMDE	BAJ		
1	G	S70 E20 003	AIR OUTLET GRILLE		1	1	1	1		
2	G	S70 E20 002	VANE ASSY		4	4	4	4		
3	G	S70 E31 638	CORNER PANEL (L)		1		1			
	G	S70 E41 638	CORNER PANEL (L)			1		1		
4	G	S70 E20 638	CORNER PANEL		3	3	3	3		
5	G	S70 E20 317	WIRELESS ADAPTER			1		1		W.B
6	G	S70 E50 658	RECEIVER			1		1		RU
7	G	S70 E20 500	L.L. FILTER-A		1	1	1	1		
8	G	S70 E20 691	GRILLE ASSY		1	1	1			
	G	S70 E30 691	GRILLE ASSY					1		
9	G	S70 E00 223	STEPPING MOTOR		4	4	4	4		MV
10	G	S70 E00 063	VANE BUSH-A		8	8	8	8		
11	G	S70 E00 040	GEAR (VANE)		4	4	4	4		
12	G	S70 E01 040	GEAR (S/M)		4	4	4	4		
13	G	—	I-SEE SENSOR	PAC-SA1ME-E	1	1	1		Optional part	
14	G	S70 E50 713	REMOTE CONTROLLER	PAR-21MAA-E			1			
15	G	S70 E40 714	REMOTE CONTROLLER	PAR-SL97A-E		1				
16	G	S70 E60 714	REMOTE CONTROLLER					1	for Auto Grille	
17	G	S70 0B0 213	MOTOR BOX					2		UK1
18	G	S70 0B6 310	CONTROLLER BOARD					1		U.B
19	G	S70 0B0 521	LIMIT SWITCH					1		LS1
⑳	G	S70 E20 305	CABLE ASSY			1		1	for W.B.	
㉑	G	S70 E20 673	SCREW ASSY		1		1	1	Accessory	
	G	S70 E30 673	SCREW ASSY			1			Accessory	

RoHS PARTS LIST

STRUCTURAL AND FUNCTIONAL PARTS

PLA-ZRP35BA.UK
 PLA-ZRP50BA.UK
 PLA-ZRP60BA.UK
 PLA-ZRP71BA.UK
 PLA-ZRP125BA.UK
 PLA-ZRP140BA.UK

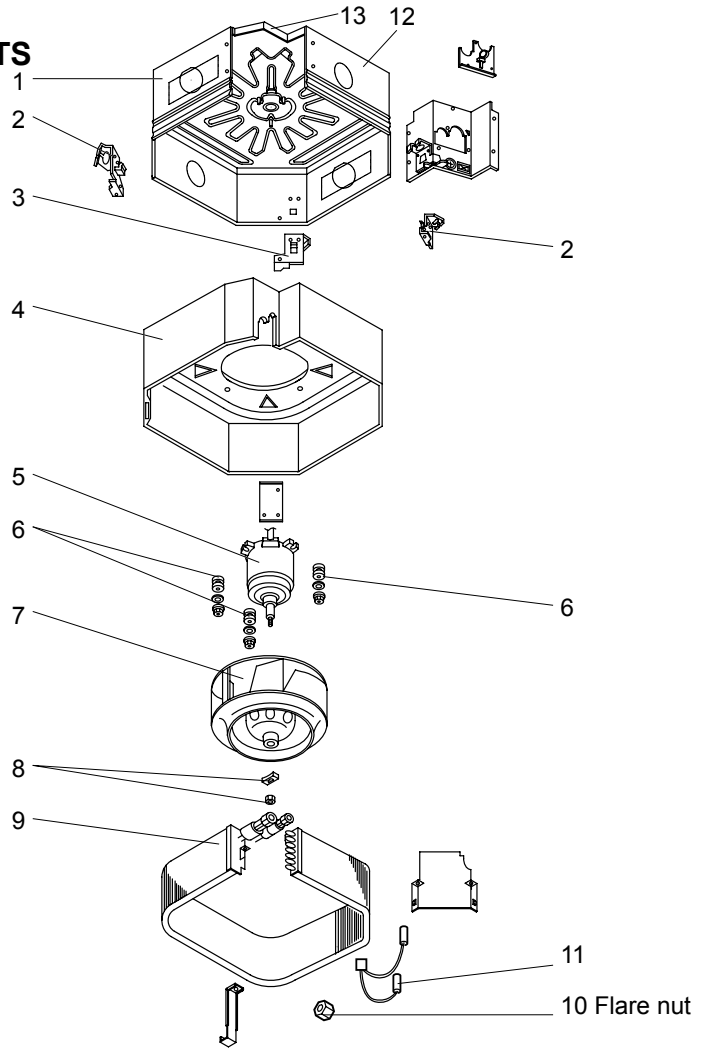

No.	RoHS	Part No.	Part Name	Specif cation	Q'ty/unit						Remarks (Drawing No.)	Wiring Diagram Symbol
					PLA-ZRP-BA.UK							
					35	50	60	71	125	140		
1	G	S70 0B3 688	DRUM 2 ASSY		1	1	1					
	G	S70 0B4 688	DRUM 2 ASSY				1	1	1			
2	G	S70 0B2 130	LEG -1A		2	2	2	2	2	2		
3	G	S70 0B1 130	LEG -1B		1	1	1	1	1	1		
4	G	S70 0B1 659	INNER COVER ASSY-S		1	1	1					
	G	S70 0B2 659	INNER COVER ASSY-L				1	1	1			
5	G	S70 0B3 762	FAN MOTOR		1	1	1					MF
	G	S70 0B2 762	FAN MOTOR				1	1	1			MF
6	G	S70 0B1 105	MOTOR MOUNT		3	3	3	3	3	3		
7	G	S70 0B3 114	TURBO FAN		1	1	1					
	G	S70 0B2 114	TURBO FAN				1	1	1			
8	G	S70 10B 097	SPL WASHER / NUT	M6	1	1	1					
	G	S70 08K 097	SPL WASHER / NUT	M6			1	1	1			
9	G	S70 0B9 480	HEAT EXCHANGER		1	1						
	G	S70 0B6 480	HEAT EXCHANGER				1					
	G	S70 0B4 480	HEAT EXCHANGER				1					
	G	S70 0B8 480	HEAT EXCHANGER					1	1			
10	G	S70 0B1 097	FLARE NUT	1/2"	1	1						
	G	S70 E10 097	FLARE NUT	1/4"	1	1						
	G	S70 E15 097	FLARE NUT	5/8"			1	1	1	1		
	G	S70 E17 097	FLARE NUT	3/8"			1	1	1	1		
11	G	S70 0B2 202	THERMISTOR		1	1	1	1	1	1		TH2/TH5
12	G	S70 0B1 688	DRUM 1 ASSY		1	1	1					
	G	S70 0B2 688	DRUM 1 ASSY				1	1	1			
13	G	S70 0B1 687	BASE		1	1	1	1	1	1		

FUNCTIONAL AND ELECTRICAL PARTS

PLA-ZRP35BA.UK
 PLA-ZRP50BA.UK
 PLA-ZRP60BA.UK
 PLA-ZRP71BA.UK
 PLA-ZRP125BA.UK
 PLA-ZRP140BA.UK

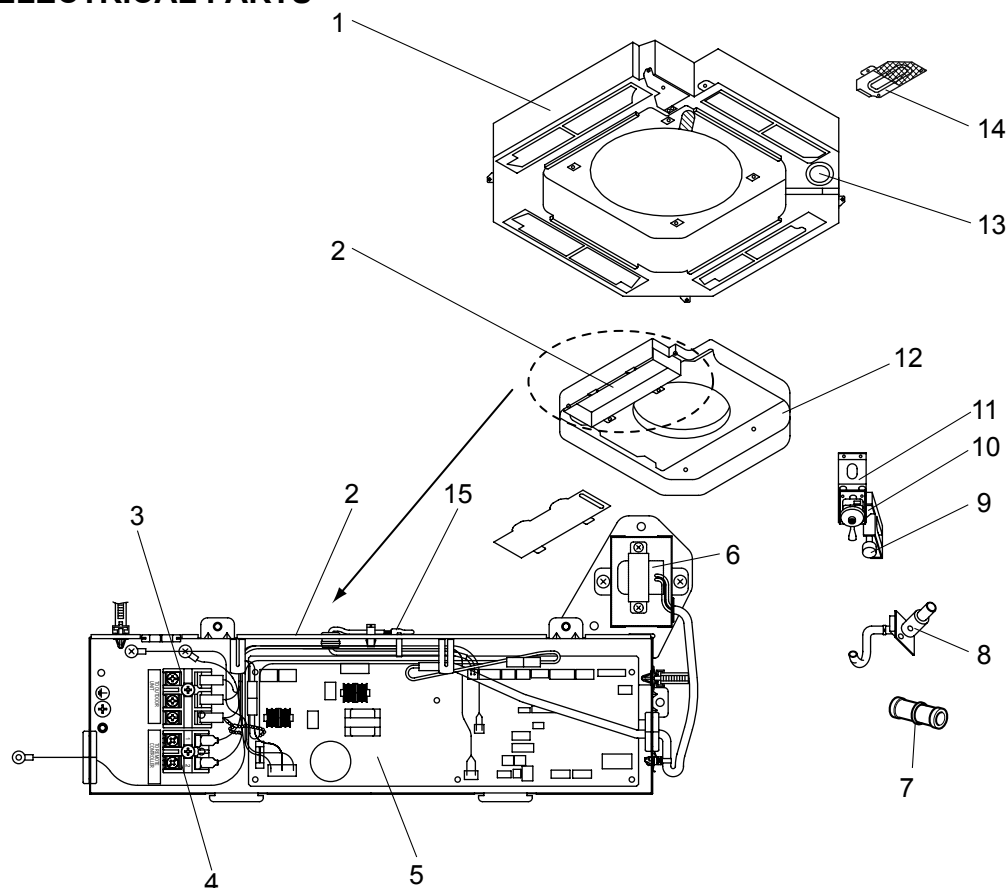

No.	ROHS	Parts No.	Parts Name	Specif cation	Q'ty/unit						Remarks (Drawing No.)	Wiring Diagram Symbol	Recom- mended Q'ty
					PLA-ZRP-BA.UK								
					35	50	60	71	125	140			
1	G	S70 0B1 529	DRAIN PAN		1	1	1	1	1	1			
2	G	S70 0B5 501	ELECTRICAL CONTROL BOX		1	1	1	1	1	1			
3	G	S70 K01 716	TERMINAL BLOCK	3P(S1,S2,S3)	1	1	1	1	1	1		TB4	
4	G	S70 512 716	TERMINAL BLOCK	2P(1,2)	1	1	1	1	1	1		TB5	
5	G	S70 B20 310	INDOOR CONTROLLER BOARD		1	1	1	1	1	1		I.B	
6	G	S70 0B1 259	REACTOR		1	1	1	1	1	1		DCL	
7	G	S70 29H 523	DRAIN SOCKET		1	1	1	1	1	1	Accessory		
8	G	S70 0B1 527	DRAIN HOSE ASSY		1	1	1	1	1	1			
9	G	S70 0B1 266	DRAIN SENSOR (FLOAT SWITCH)		1	1	1	1	1	1		FS	
10	G	S70 0B1 533	DRAIN SENSOR HOLDER		1	1	1	1	1	1			
11	G	S70 0B1 355	DRAIN PUMP		1	1	1	1	1	1		DP	
12	G	S70 0B1 502	BELLMOUTH		1	1	1	1	1	1			
13	G	S70 A41 524	DRAIN PLUG		1	1	1	1	1	1			
14	G	S70 0B1 663	CORNER COVER		1	1	1	1	1	1			
15	G	S70 0B1 202	ROOM TEMP. THERMISTOR		1	1	1	1	1	1		TH1	

MITSUBISHI ELECTRIC CORPORATION

HEAD OFFICE : TOKYO BLDG., 2-7-3, MARUNOUCHI, CHIYODA-KU, TOKYO 100-8310, JAPAN