

Air-Conditioners For Building Application

2001**TECHNICAL & SERVICE MANUAL****Series PFFY Floor Standing Type**

<Indoor unit>

Models

PFFY-P20VLEM-A, PFFY-P20VLRM-A
PFFY-P25VLEM-A, PFFY-P25VLRM-A
PFFY-P32VLEM-A, PFFY-P32VLRM-A
PFFY-P40VLEM-A, PFFY-P40VLRM-A
PFFY-P50VLEM-A, PFFY-P50VLRM-A
PFFY-P63VLEM-A, PFFY-P63VLRM-A

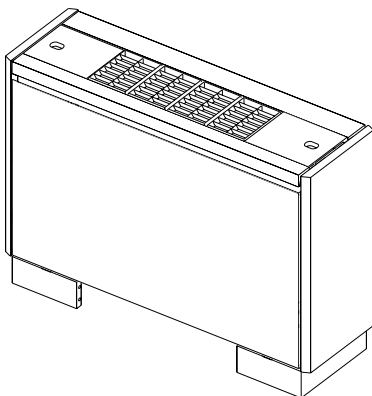

Exposed type

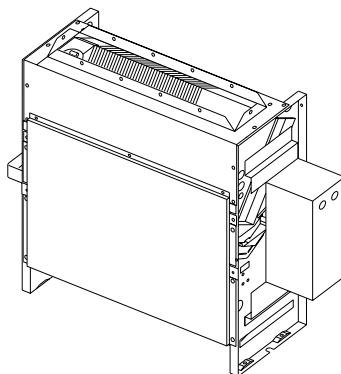

Concealed type

CONTENTS

| | |
|-------------------------------------|----|
| SAFETY PRECAUTIONS | 1 |
| 1. FEATURES | 3 |
| 2. PART NAMES AND FUNCTIONS | 4 |
| 3. SPECIFICATION | 6 |
| 4. OUTLINES AND DIMENSIONS | 8 |
| 5. WIRING DIAGRAM | 10 |
| 6. REFRIGERANT SYSTEM DIAGRAM | 11 |
| 7. TROUBLE SHOOTING | 12 |
| 8. DISASSEMBLY PROCEDURE | 17 |

CITY MULTI**For use with the R407C & R22**

SAFETY PRECAUTIONS

1. Before installation and electric work

- ▶ **Before installing the unit, make sure you read all the “Safety precautions”.**
- ▶ **The “Safety precautions” provide very important points regarding safety. Make sure you follow them.**
- ▶ **This equipment may not be applicable to EN61000-3-2: 1995 and EN61000-3-3: 1995.**
- ▶ **This equipment may have an adverse effect equipment on the same electrical supply system.**
- ▶ **Please report to or take consent by the supply authority before connection to the system.**

Symbols used in the text

Warning:

Describes precautions that should be observed to prevent danger of injury or death to the user.

Caution:

Describes precautions that should be observed to prevent damage to the unit.

Symbols used in the illustrations



: Indicates an action that must be avoided.



: Indicates that important instructions must be followed.



: Indicates a part which must be grounded.



: Indicates that caution should be taken with rotating parts. (This symbol is displayed on the main unit label.) <Color: Yellow>



: Beware of electric shock (This symbol is displayed on the main unit label.) <Color: Yellow>

Warning:

Carefully read the labels affixed to the main unit.

Warning:

- **Ask the dealer or an authorized technician to install the air conditioner.**
 - Improper installation by the user may result in water leakage, electric shock, or fire.
- **Install the air unit at a place that can withstand its weight.**
 - Inadequate strength may cause the unit to fall down, resulting in injuries.
- **Use the specified cables for wiring. Make the connections securely so that the outside force of the cable is not applied to the terminals.**
 - Inadequate connection and fastening may generate heat and cause a fire.
- **Prepare for typhoons and other strong winds and earthquakes and install the unit at the specified place.**
 - Improper installation may cause the unit to topple and result in injury.
- **Always use an air cleaner, humidifier, electric heater, and other accessories specified by Mitsubishi Electric.**
 - Ask an authorized technician to install the accessories. Improper installation by the user may result in water leakage, electric shock, or fire.

- **Never repair the unit. If the air conditioner must be repaired, consult the dealer.**
 - If the unit is repaired improperly, water leakage, electric shock, or fire may result.
- **Do not touch the heat exchanger fins.**
 - Improper handling may result in injury.
- **If refrigerant gas leaks during installation work, ventilate the room.**
 - If the refrigerant gas comes into contact with a flame, poisonous gases will be released.
- **Install the air conditioner according to this Installation Manual.**
 - If the unit is installed improperly, water leakage, electric shock, or fire may result.
- **Have all electric work done by a licensed electrician according to “Electric Facility Engineering Standard” and “Interior Wire Regulations” and the instructions given in this manual and always use a special circuit.**
 - If the power source capacity is inadequate or electric work is performed improperly, electric shock and fire may result.
- **Securely install the cover of control box and the panel.**
 - If the cover and panel are not installed properly, dust or water may enter the outdoor unit and fire or electric shock may result.
- **When installing and moving the air conditioner to another site, do not charge the it with a refrigerant different from the refrigerant (R407C or R22) specified on the unit.**
 - If a different refrigerant or air is mixed with the original refrigerant, the refrigerant cycle may malfunction and the unit may be damaged.
- **If the air conditioner is installed in a small room, measures must be taken to prevent the refrigerant concentration from exceeding the safety limit even if the refrigerant should leak.**
 - Consult the dealer regarding the appropriate measures to prevent the safety limit from being exceeded. Should the refrigerant leak and cause the safety limit to be exceeded, hazards due to lack of oxygen in the room could result.
- **When moving and reinstalling the air conditioner, consult the dealer or an authorized technician.**
 - If the air conditioner is installed improperly, water leakage, electric shock, or fire may result.
- **After completing installation work, make sure that refrigerant gas is not leaking.**
 - If the refrigerant gas leaks and is exposed to a fan heater, stove, oven, or other heat source, it may generate noxious gases.
- **Do not reconstruct or change the settings of the protection devices.**
 - If the pressure switch, thermal switch, or other protection device is shorted and operated forcibly, or parts other than those specified by Mitsubishi Electric are used, fire or explosion may result.

2. Precautions for devices that use R407C refrigerant

⚠ Caution:

- **Do not use the existing refrigerant piping.**
 - The old refrigerant and refrigerator oil in the existing piping contains a large amount of chlorine which may cause the refrigerator oil of the new unit to deteriorate.
 - **Use refrigerant piping made of C1220 (CU-DHP) phosphorus deoxidized copper as specified in the *JIS H3300 "Copper and copper alloy seamless pipes and tubes". In addition, be sure that the inner and outer surfaces of the pipes are clean and free of hazardous sulphur, oxides, dust/dirt, shaving particles, oils, moisture, or any other contaminant.**
 - Contaminants on the inside of the refrigerant piping may cause the refrigerant residual oil to deteriorate.
- *JIS: Japanese Industrial Standard
- **Store the piping to be used during installation indoors and keep both ends of the piping sealed until just before brazing. (Store elbows and other joints in a plastic bag.)**
 - If dust, dirt, or water enters the refrigerant cycle, deterioration of the oil and compressor trouble may result.
 - **Use ester oil, ether oil or alkylbenzene (small amount) as the refrigerator oil to coat flares and flange connections.**
 - The refrigerator oil will degrade if it is mixed with a large amount of mineral oil.
 - **Use liquid refrigerant to fill the system.**
 - If gas refrigerant is used to seal the system, the composition of the refrigerant in the cylinder will change and performance may drop.
 - **Do not use a refrigerant other than R407C.**
 - If another refrigerant (R22, etc.) is used, the chlorine in the refrigerant may cause the refrigerator oil to deteriorate.
 - **Use a vacuum pump with a reverse flow check valve..**
 - The vacuum pump oil may flow back into the refrigerant cycle and cause the refrigerator oil to deteriorate.
 - **Do not use the following tools that are used with conventional refrigerants.**
(Gauge manifold, charge hose, gas leak detector, reverse flow check valve, refrigerant charge base, vacuum gauge, refrigerant recovery equipment)
 - If the conventional refrigerant and refrigerator oil are mixed in the R407C, the refrigerant may deteriorate.
 - If water is mixed in the R407C, the refrigerator oil may deteriorate.
 - Since R407C does not contain any chlorine, gas leak detectors for conventional refrigerants will not react to it.
 - **Do not use a charging cylinder.**
 - Using a charging cylinder may cause the refrigerant to deteriorate.
 - **Be especially careful when managing the tools.**
 - If dust, dirt, or water gets in the refrigerant cycle, the refrigerant may deteriorate.

1

FEATURES

Series PFFY Floor Standing Type

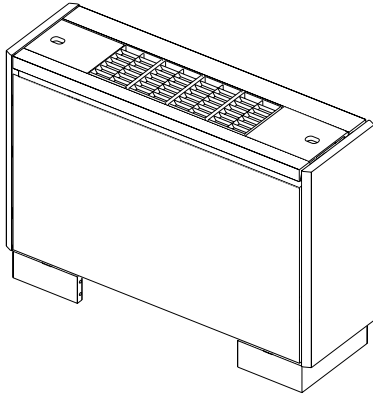

Exposed type

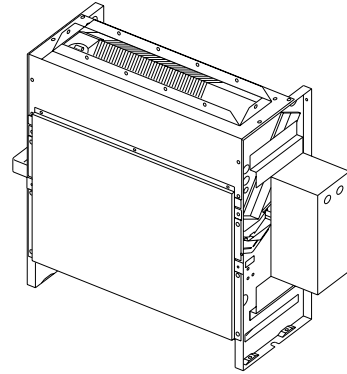

Concealed type

| Models | Cooling capacity/Heating capacity |
|-------------------------------|-----------------------------------|
| | kW |
| PFFY-P20VLEM-A,PFFY-P20VLRM-A | 2.2/ 2.5 |
| PFFY-P25VLEM-A,PFFY-P25VLRM-A | 2.8/ 3.2 |
| PFFY-P32VLEM-A,PFFY-P32VLRM-A | 3.6/ 4.0 |
| PFFY-P40VLEM-A,PFFY-P40VLRM-A | 4.5/ 5.0 |
| PFFY-P50VLEM-A,PFFY-P50VLRM-A | 5.6/ 6.3 |
| PFFY-P63VLEM-A,PFFY-P63VLRM-A | 7.1/ 8.0 |

2

PART NAMES AND FUNCTIONS

Indoor (Main) Unit

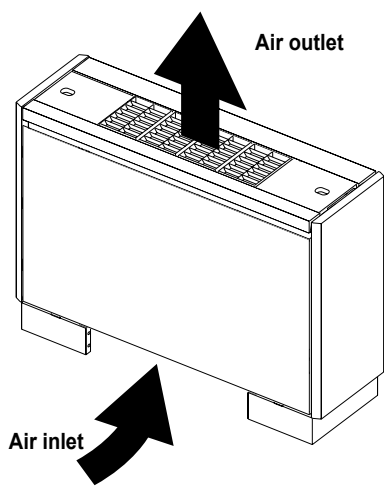

Exposed type

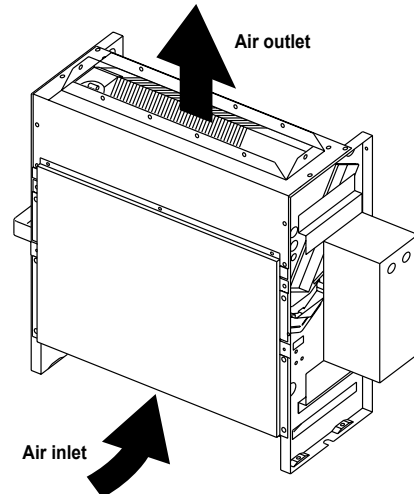

Concealed type

Remote controller [PAR-20MAA]

Once the controls are set, the same operation mode can be repeated by simply pressing the ON/OFF button.

Operation buttons

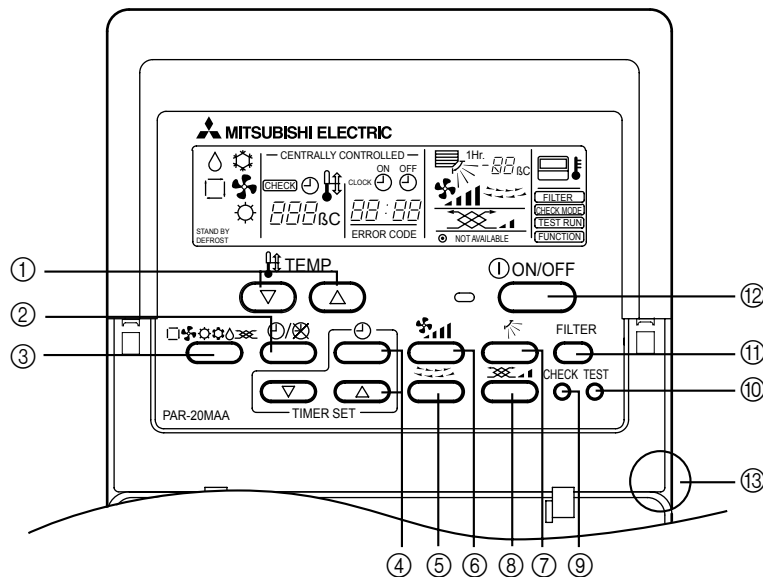

- | | |
|--|---|
| ① [Room temperature adjustment] Button | ⑦ [Up/down airflow direction] Button |
| ② [Timer/continuous] Button | ⑧ [Ventilation] Button |
| ③ [Selecting operation] Button | ⑨ [Checking/built-in] Button |
| ④ [Time selection] Button [Time-setting] Button | ⑩ [Test run] Button |
| ⑤ [Louver] Button | ⑪ [Filter] Button |
| ⑥ [Fan speed adjustment] Button | ⑫ [ON/OFF] Button |
| | ⑬ Position of built-in room temperature |

⚠Never expose the remote controller to direct sunlight. Doing so can result in the erroneous measurement of room temperature.

⚠Never place any obstacle around the lower right-hand section of the remote controller. Doing so can result in the erroneous measurement of room temperature.

Display

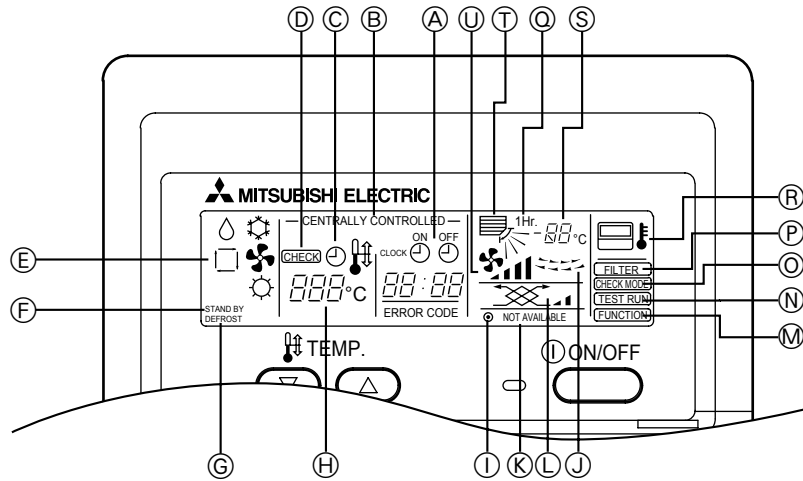

- (A) Current time/Timer
- (B) Centralized control
- (C) Timer ON
- (D) Abnormality occurs
- (E) Operation mode: COOL, DRY, AUTO, FAN, HEAT
- (F) Preparing for Heating mode
- (G) Defrost mode
- (H) Set temperature
- (I) Power ON
- (J) Louver
- (K) Not available function
- (L) Ventilation
- (M) Function setting mode
- (N) Test run mode
- (O) Error check mode
- (P) Filter sign
- (Q) Set effective for 1 hr.
- (R) Sensor position
- (S) Room temperature
- (T) Airflow
- (U) Fan speed

3

SPECIFICATION

3-1. Specification

| Item | | Model | PFFY-P20 VLEM-A | | PFFY-P25 VLEM-A | | PFFY-P32 VLEM-A | | PFFY-P40 VLEM-A | | PFFY-P50 VLEM-A | | PFFY-P63 VLEM-A | | | |
|------------------------------|--------------------------|---------------------|---|---------|--------------------|---------|--------------------|---------|--------------------|---------|--------------------|---------|--------------------|---------|-------|--|
| Power source | Voltage | ~V | 220-240 | 208-230 | 220-240 | 208-230 | 220-240 | 208-230 | 220-240 | 208-230 | 220-240 | 208-230 | 220-240 | 208-230 | | |
| | Frequency | Hz | 50 | 60 | 50 | 60 | 50 | 60 | 50 | 60 | 50 | 60 | 50 | 60 | | |
| Cooling capacity | | kW | 2.2 | | 2.8 | | 3.6 | | 4.5 | | 5.6 | | 7.1 | | | |
| Heating capacity | | kW | 2.5 | | 3.2 | | 4.0 | | 5.0 | | 6.3 | | 8.0 | | | |
| Power consumption | Cooling | kW | 0.04 | 0.06 | 0.04 | 0.06 | 0.06 | 0.07 | 0.065 | 0.075 | 0.085 | 0.09 | 0.10 | 0.11 | | |
| | Heating | kW | 0.04 | 0.06 | 0.04 | 0.06 | 0.06 | 0.07 | 0.065 | 0.075 | 0.085 | 0.09 | 0.10 | 0.11 | | |
| Current | Cooling | A | 0.19 | 0.25 | 0.19 | 0.25 | 0.29 | 0.30 | 0.32 | 0.33 | 0.40 | 0.41 | 0.46 | 0.47 | | |
| | Heating | A | 0.19 | 0.25 | 0.19 | 0.25 | 0.29 | 0.30 | 0.32 | 0.33 | 0.40 | 0.41 | 0.46 | 0.47 | | |
| External finish (Munsel No.) | | | Galvanized steel plate (5Y 8/1) | | | | | | | | | | | | | |
| Dimension | Height | mm | 630 | | | | | | | | | | | | | |
| | Width | mm | 1050 | | | | 1170 | | | | 1410 | | | | | |
| | Depth | mm | 220 | | | | | | | | | | | | | |
| Net weight | | kg | 23 | | 23 | | 25 | | 26 | | 30 | | 32 | | | |
| Heat exchanger | | | Cross fin(Aluminium plate fin and copper tube) | | | | | | | | | | | | | |
| Fan | Type | | Sirocco fanX1 | | | | | | Sirocco fanX2 | | | | | | | |
| | Airflow rate (Low-High) | m ³ /min | 5.5-6.5 | | 5.5-6.5 | | 7.0-9.0 | | 9.0-11.0 | | 12.0-14.0 | | 12.0-15.5 | | | |
| | External static pressure | Pa | 0 | | | | | | | | | | | | | |
| Motor | Type | | Single phase induction motor | | | | | | | | | | | | | |
| | Output | kW | 0.015 | | 0.015 | | 0.018 | | 0.030 | | 0.035 | | 0.050 | | | |
| Air filter | | | PP Honeycomb fabric | | | | | | | | | | | | | |
| Refrigerant pipe dimension | Gas(Flare) | mm | ø 12.7 | | | | | | ø 15.88 | | | | | | | |
| | Liquid(Flare) | mm | ø 6.35 | | | | | | ø 9.52 | | | | | | | |
| Drain pipe dimension | | | Accessory hose (top end:20) | | | | | | | | | | | | | |
| Noise level (Low-High) | | | 34-40 | | | | 35-40 | | | | 38-43 | | | | 40-46 | |

Note:1

Note:1

Note:2

Note:2

| Item | | Model | PFFY-P20 VLRM-A | | PFFY-P25 VLRM-A | | PFFY-P32 VLRM-A | | PFFY-P40 VLRM-A | | PFFY-P50 VLRM-A | | PFFY-P63 VLRM-A | | | |
|------------------------------|--------------------------|---------------------|---|---------|--------------------|---------|--------------------|---------|--------------------|---------|--------------------|---------|--------------------|---------|-------|--|
| Power source | Voltage | ~V | 220-240 | 208-230 | 220-240 | 208-230 | 220-240 | 208-230 | 220-240 | 208-230 | 220-240 | 208-230 | 220-240 | 208-230 | | |
| | Frequency | Hz | 50 | 60 | 50 | 60 | 50 | 60 | 50 | 60 | 50 | 60 | 50 | 60 | | |
| Cooling capacity | | kW | 2.2 | | 2.8 | | 3.6 | | 4.5 | | 5.6 | | 7.1 | | | |
| Heating capacity | | kW | 2.5 | | 3.2 | | 4.0 | | 5.0 | | 6.3 | | 8.0 | | | |
| Power consumption | Cooling | kW | 0.04 | 0.06 | 0.04 | 0.06 | 0.06 | 0.07 | 0.065 | 0.075 | 0.085 | 0.09 | 0.10 | 0.11 | | |
| | Heating | kW | 0.04 | 0.06 | 0.04 | 0.06 | 0.06 | 0.07 | 0.065 | 0.075 | 0.085 | 0.09 | 0.10 | 0.11 | | |
| Current | Cooling | A | 0.19 | 0.25 | 0.19 | 0.25 | 0.29 | 0.30 | 0.32 | 0.33 | 0.40 | 0.41 | 0.46 | 0.47 | | |
| | Heating | A | 0.19 | 0.25 | 0.19 | 0.25 | 0.29 | 0.30 | 0.32 | 0.33 | 0.40 | 0.41 | 0.46 | 0.47 | | |
| External finish (Munsel No.) | | | Galvanized steel plate | | | | | | | | | | | | | |
| Dimension | Height | mm | 639 | | | | | | | | | | | | | |
| | Width | mm | 886 | | | | 1006 | | | | 1246 | | | | | |
| | Depth | mm | 220 | | | | | | | | | | | | | |
| Net weight | | kg | 18.5 | | 18.5 | | 20 | | 21 | | 25 | | 27 | | | |
| Heat exchanger | | | Cross fin(Aluminium plate fin and copper tube) | | | | | | | | | | | | | |
| Fan | Type | | Sirocco fanX1 | | | | | | Sirocco fanX2 | | | | | | | |
| | Airflow rate (Low-High) | m ³ /min | 5.5-6.5 | | 5.5-6.5 | | 7.0-9.0 | | 9.0-11.0 | | 12.0-14.0 | | 12.0-15.5 | | | |
| | External static pressure | Pa | 0 | | | | | | | | | | | | | |
| Motor | Type | | Single phase induction motor | | | | | | | | | | | | | |
| | Output | kW | 0.015 | | 0.015 | | 0.018 | | 0.030 | | 0.035 | | 0.050 | | | |
| Air filter | | | PP Honeycomb fabric | | | | | | | | | | | | | |
| Refrigerant pipe dimension | Gas(Flare) | mm | ø 12.7 | | | | | | ø 15.88 | | | | | | | |
| | Liquid(Flare) | mm | ø 6.35 | | | | | | ø 9.52 | | | | | | | |
| Drain pipe dimension | | | Accessory hose (top end:20) | | | | | | | | | | | | | |
| Noise level (Low-High) | | | 34-40 | | | | 35-40 | | | | 38-43 | | | | 40-46 | |

Note:1

Note:1

Note:2

Note:2

Note: 1.Cooling / Heating capacity indicates the maximum value at operation under the following condition.

Cooling :Indoor 27°CDB/19 °CWB
:Outdoor 35°CDB

Heating :Indoor 20°C
:Outdoor 7°CDB/6°CWB

2.The figures represent a 240V/50Hz or 230V/60Hz unit measured at a point which is 1m away from the front of the unit and at a height of 1m from the floor.

The noise is approximately 1dB(A) less for a 230V/50Hz or 220V/60Hz unit and approximately 2dB(A) less for a 220V/50Hz or 208V/60Hz unit. The noise is approximately 3dB(A) less when the measurement point is 1.5m away from the front of the unit and at a height of 1.5m from the floor.

3-2. Electrical parts specification

| Parts name | Model Symbol | PFFY-P20 (VLEM-A VLRM-A) | PFFY-P25 (VLEM-A VLRM-A) | PFFY-P32 (VLEM-A VLRM-A) | PFFY-P40 (VLEM-A VLRM-A) | PFFY-P50 (VLEM-A VLRM-A) | PFFY-P63 (VLEM-A VLRM-A) |
|--|-----------------|--|------------------------------------|------------------------------------|------------------------------------|-----------------------------------|---|
| Transformer | T | (Primary) 50/60Hz 220-240V (Secondary) (18.4V 1.7A) | | | | | |
| Room temperature thermistor | TH21 | Resistance 0°C/15kΩ,10°C/9.6kΩ,20°C/6.3kΩ,25°C/5.4kΩ,30°C/4.3kΩ,40°C/3.0kΩ | | | | | |
| Liquid pipe thermistor | TH22 | Resistance 0°C/15kΩ,10°C/9.6kΩ,20°C/6.3kΩ,25°C/5.4kΩ,30°C/4.3kΩ,40°C/3.0kΩ | | | | | |
| Gas pipe thermistor | TH23 | Resistance 0°C/15kΩ,10°C/9.6kΩ,20°C/6.3kΩ,25°C/5.4kΩ,30°C/4.3kΩ,40°C/3.0kΩ | | | | | |
| Fuse (Indoor controller board) | FUSE | 250V 6.3A | | | | | |
| Fan motor (with Inner-thermostat) | MF1,2 | 4-pole OUTPUT 15W CU-0206B-A | 4-pole OUTPUT 15W CU-0206B-A | 4-pole OUTPUT 18W CU-0207B-A | 4-pole OUTPUT 30W CU-0303B-A | 4-pole OUTPUT 35W CRC4415AB | 4-pole OUTPUT 50W CU-0507B-A |
| Inner-thermostat/ thermofuse (Fan motor) | | OFF 130°C±5°C ON 90°C±20°C | | | | | FUSE 152°C ₀ ^{+5°C} CUT OFF |
| Fan motor capacitor | C1 | 1.5μF X 440V | | | | 2.0μF X 440V | 2.5μF X 440V |
| Linear expansion valve | LEV | DC12V Stepping motor drive port dimension 3.2Ω (0~2000pulse) EDM-402MD | | | | | |
| Power supply terminal bed | TB2 | (L,N,⊕) 330V 30A | | | | | |
| Transmission terminal bed | TB5 TB15 | (1,2),(M1,M2,S)300V 10A | | | | | |

4 OUTLINES AND DIMENSIONS

Indoor Unit
PFFY-P20-25-32-40-50-63VLEM-A

Unit:mm

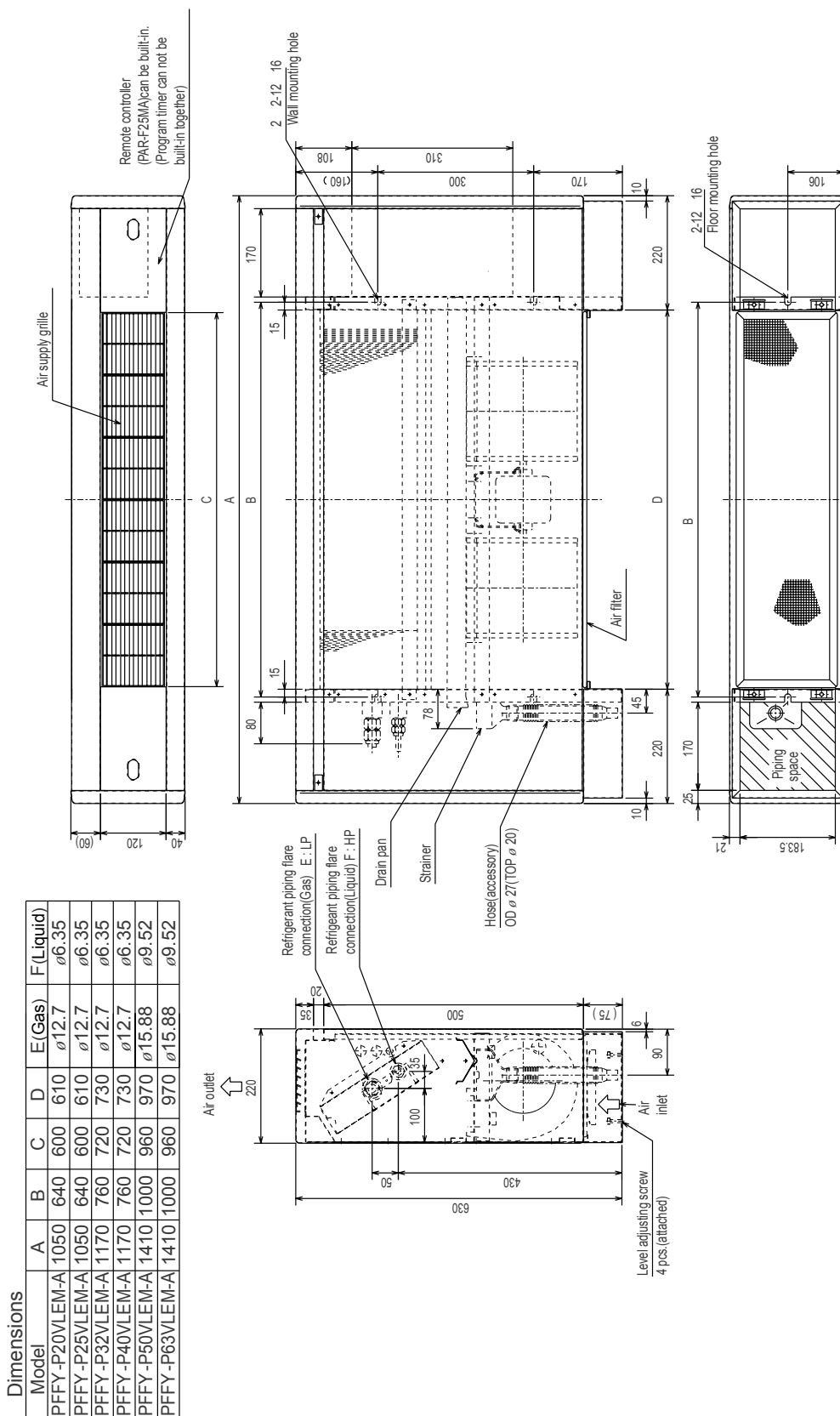

Indoor Unit
PFFY-P20-25-32-40-50-63VLRM-A

Unit:mm

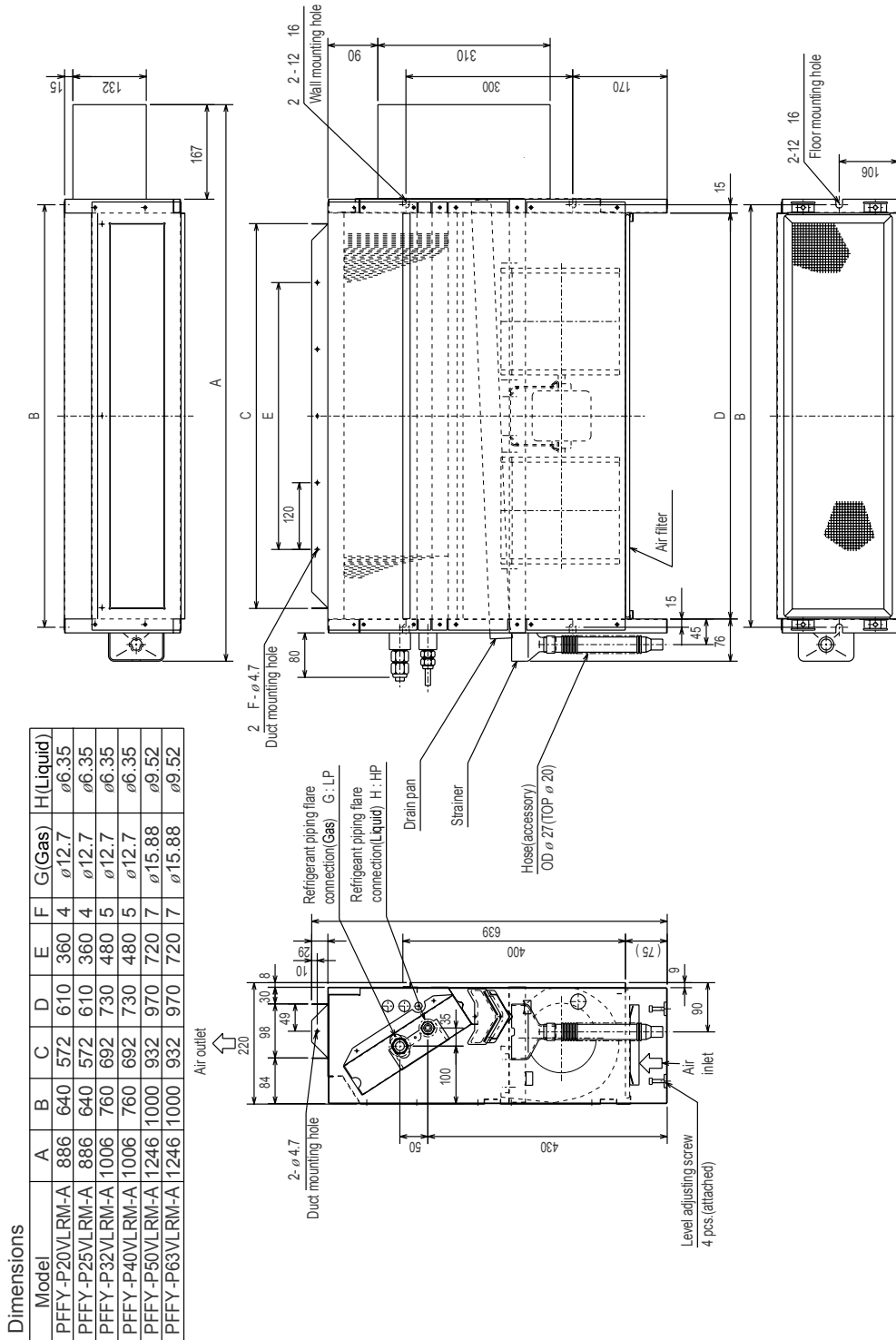

5

WIRING DIAGRAM

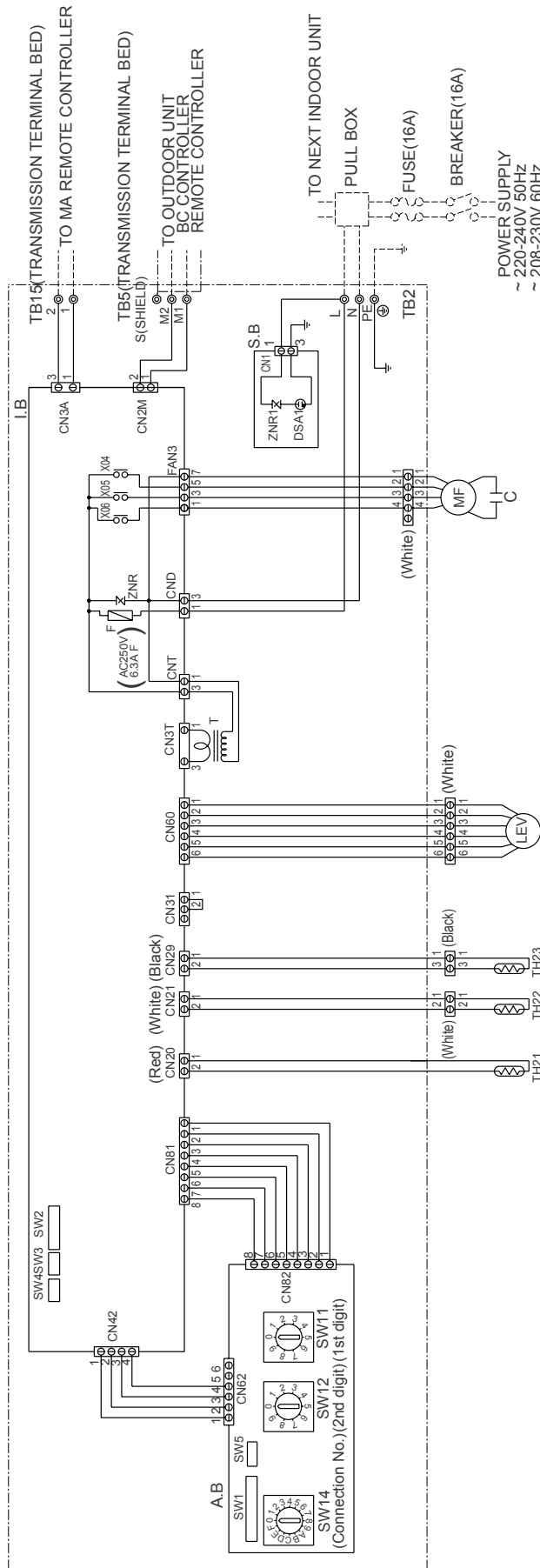

SYMBOL EXPLANATION

| SYMBOL | NAME | SYMBOL | NAME |
|--------|-----------------------------------|---------------|---|
| MF | Fan motor | TH22 | Thermistor (piping temp.detection/liquid) |
| C | Capacitor (for MF) | TH23 | Thermistor (piping temp.detection/gas) |
| I . B | Indoor controller board | SW 11 (A . B) | Switch (1st digit address set) |
| A . B | Address board | SW 12 (A . B) | Switch (2nd digit address set) |
| TB 2 | Power source terminal bed | SW 14 (A . B) | Switch (connection No.set) |
| TB 5 | Transmission terminal bed | SW 1 (A . B) | Switch(for mode selection) |
| TB 15 | Transmission terminal bed | SW 2 (I . B) | Switch(for capacity code) |
| F | Fuse AC250V 6.3A F | SW 3 (I . B) | Switch(for mode selection) |
| T | Transformer | SW 4 (I . B) | Switch(for model selection) |
| LEV | Electronic linear expans. valve | SW 5 (A . B) | Switch(for voltage selection) |
| S . B | Surge absorber board | X 0 4 ~ 0 6 | Aux.relay |
| TH 21 | Thermistor (inlet temp.detection) | | |

Capacitor
 MODELS 20/25/32/40 1.5 F
 MODEL 50 2.0 F
 MODEL 63 2.5 F

6

REFRIGERANT SYSTEM DIAGRAM

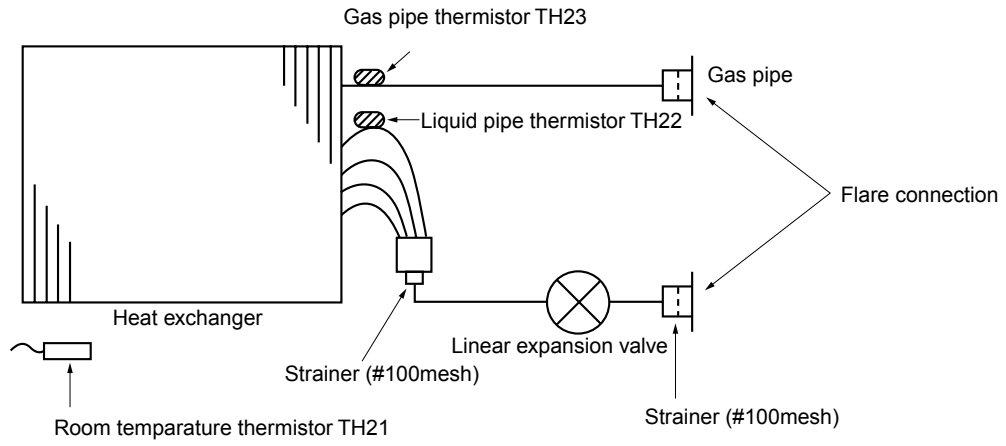

| Item | Capacity | |
|-------------|--|--|
| | PFFY -P20,25,32,40VLEM-A PFFY -P20,25,32,40VLRM-A | PFFY -P50,63VLEM-A PFFY -P50,63VLRM-A |
| Gas pipe | $\phi 12.7 < 1/2F >$ | $\phi 15.88 < 5/8F >$ |
| Liquid pipe | $\phi 6.35 < 1/4F >$ | $\phi 9.52 < 3/8F >$ |

7

TROUBLE SHOOTING

7-1. How to check the parts

| Parts name | Check points | | | | | | | | | | | | | | | | | | | | | | | | | | | | | | | | | | | | |
|---|--|-----------------------------------|-----------------------|---------------|---------------|---------------|----------------------|-------------------------|-----------------------|-----------------------|---------------|---------------|--------------|-------|--------------|-------|---------------|--------------|-------|-------|------|------|---------------|------|------|------|------|--------------|------|------|------|------|--------------|--|--|--|--|
| Room temperature thermistor (TH21) Liquid pipe thermistor (TH22) Gas pipe thermistor (TH23) | Disconnect the connector, then measure the resistance using a tester. (Surrounding temperature 10°C~30°C) <table border="1" style="margin-left: 20px;"> <thead> <tr> <th>Normal</th> <th>Abnormal</th> </tr> </thead> <tbody> <tr> <td>4.3kΩ~9.6kΩ</td> <td>Open or short</td> </tr> </tbody> </table> (Refer to the thermistor characteristic graph on next page.) | Normal | Abnormal | 4.3kΩ~9.6kΩ | Open or short | | | | | | | | | | | | | | | | | | | | | | | | | | | | | | | | |
| Normal | Abnormal | | | | | | | | | | | | | | | | | | | | | | | | | | | | | | | | | | | | |
| 4.3kΩ~9.6kΩ | Open or short | | | | | | | | | | | | | | | | | | | | | | | | | | | | | | | | | | | | |
| Transformer | Disconnect the connector and measure the resistance using a tester. <table border="1" style="margin-left: 20px;"> <thead> <tr> <th></th> <th>Normal</th> <th>Abnormal</th> </tr> </thead> <tbody> <tr> <td>CNT(1)-(3)</td> <td>App.45Ω</td> <td rowspan="2">Open or short</td> </tr> <tr> <td>CN3T(1)-(3)</td> <td>App.1Ω</td> </tr> </tbody> </table> | | Normal | Abnormal | CNT(1)-(3) | App.45Ω | Open or short | CN3T(1)-(3) | App.1Ω | | | | | | | | | | | | | | | | | | | | | | | | | | | | |
| | Normal | Abnormal | | | | | | | | | | | | | | | | | | | | | | | | | | | | | | | | | | | |
| CNT(1)-(3) | App.45Ω | Open or short | | | | | | | | | | | | | | | | | | | | | | | | | | | | | | | | | | | |
| CN3T(1)-(3) | App.1Ω | | | | | | | | | | | | | | | | | | | | | | | | | | | | | | | | | | | | |
| Linear expansion valve | Disconnect the connector then measure the resistance valve using a tester. Refer to the next page for a detail. <table border="1" style="margin-left: 20px;"> <thead> <tr> <th colspan="4">Normal</th> <th>Abnormal</th> </tr> </thead> <tbody> <tr> <td>(1)-(5) White-Red</td> <td>(2)-(6) Yellow-Blown</td> <td>(3)-(5) Orange-Red</td> <td>(4)-(6) Blue-Brown</td> <td rowspan="2">Open or short</td> </tr> <tr> <td colspan="4" style="text-align: center;">150Ω ±10%</td> </tr> </tbody> </table> | Normal | | | | Abnormal | (1)-(5) White-Red | (2)-(6) Yellow-Blown | (3)-(5) Orange-Red | (4)-(6) Blue-Brown | Open or short | 150Ω ±10% | | | | | | | | | | | | | | | | | | | | | | | | | |
| Normal | | | | Abnormal | | | | | | | | | | | | | | | | | | | | | | | | | | | | | | | | | |
| (1)-(5) White-Red | (2)-(6) Yellow-Blown | (3)-(5) Orange-Red | (4)-(6) Blue-Brown | Open or short | | | | | | | | | | | | | | | | | | | | | | | | | | | | | | | | | |
| 150Ω ±10% | | | | | | | | | | | | | | | | | | | | | | | | | | | | | | | | | | | | | |
| Fan motor PFFY-P20~50 VLEM-A/VLRM-A | Measure the resistance between the terminals using a tester. (at 20°C) <table border="1" style="margin-left: 20px;"> <thead> <tr> <th rowspan="2">Motor terminal or Relay connector</th> <th colspan="4">Normal</th> <th rowspan="2">Abnormal</th> </tr> <tr> <th>P20,P25</th> <th>P32</th> <th>P40</th> <th>P50</th> </tr> </thead> <tbody> <tr> <td>Black - White</td> <td>335.0</td> <td>294.0</td> <td>114.0</td> <td>101.4</td> <td rowspan="5">Open or short</td> </tr> <tr> <td>Red - Yellow</td> <td>174.0</td> <td>150.0</td> <td>80.0</td> <td>60.3</td> </tr> <tr> <td>Yellow - Blue</td> <td>56.8</td> <td>52.0</td> <td>30.0</td> <td>15.1</td> </tr> <tr> <td>Blue - Black</td> <td>99.6</td> <td>78.0</td> <td>42.0</td> <td>29.4</td> </tr> <tr> <td>Blue - White</td> <td></td> <td></td> <td></td> <td></td> </tr> </tbody> </table> | Motor terminal or Relay connector | Normal | | | | Abnormal | P20,P25 | P32 | P40 | P50 | Black - White | 335.0 | 294.0 | 114.0 | 101.4 | Open or short | Red - Yellow | 174.0 | 150.0 | 80.0 | 60.3 | Yellow - Blue | 56.8 | 52.0 | 30.0 | 15.1 | Blue - Black | 99.6 | 78.0 | 42.0 | 29.4 | Blue - White | | | | |
| Motor terminal or Relay connector | Normal | | | | Abnormal | | | | | | | | | | | | | | | | | | | | | | | | | | | | | | | | |
| | P20,P25 | P32 | P40 | P50 | | | | | | | | | | | | | | | | | | | | | | | | | | | | | | | | | |
| Black - White | 335.0 | 294.0 | 114.0 | 101.4 | Open or short | | | | | | | | | | | | | | | | | | | | | | | | | | | | | | | | |
| Red - Yellow | 174.0 | 150.0 | 80.0 | 60.3 | | | | | | | | | | | | | | | | | | | | | | | | | | | | | | | | | |
| Yellow - Blue | 56.8 | 52.0 | 30.0 | 15.1 | | | | | | | | | | | | | | | | | | | | | | | | | | | | | | | | | |
| Blue - Black | 99.6 | 78.0 | 42.0 | 29.4 | | | | | | | | | | | | | | | | | | | | | | | | | | | | | | | | | |
| Blue - White | | | | | | | | | | | | | | | | | | | | | | | | | | | | | | | | | | | | | |
| PFFY-P63 VLEM-A/VLRM-A | Measure the resistance between the terminals using a tester. (at 20°C) <table border="1" style="margin-left: 20px;"> <thead> <tr> <th rowspan="2">Motor terminal or Relay connector</th> <th>Normal</th> <th rowspan="2">Abnormal</th> </tr> <tr> <th>P63</th> </tr> </thead> <tbody> <tr> <td>Black - White</td> <td>112.0</td> <td rowspan="5">Open or short</td> </tr> <tr> <td>Red - Yellow</td> <td>78.0</td> </tr> <tr> <td>Yellow - Blue</td> <td>12.7</td> </tr> <tr> <td>Blue - Black</td> <td>50.8</td> </tr> <tr> <td>Blue - White</td> <td></td> </tr> </tbody> </table> | Motor terminal or Relay connector | Normal | Abnormal | P63 | Black - White | 112.0 | Open or short | Red - Yellow | 78.0 | Yellow - Blue | 12.7 | Blue - Black | 50.8 | Blue - White | | | | | | | | | | | | | | | | | | | | | | |
| Motor terminal or Relay connector | Normal | | Abnormal | | | | | | | | | | | | | | | | | | | | | | | | | | | | | | | | | | |
| | P63 | | | | | | | | | | | | | | | | | | | | | | | | | | | | | | | | | | | | |
| Black - White | 112.0 | Open or short | | | | | | | | | | | | | | | | | | | | | | | | | | | | | | | | | | | |
| Red - Yellow | 78.0 | | | | | | | | | | | | | | | | | | | | | | | | | | | | | | | | | | | | |
| Yellow - Blue | 12.7 | | | | | | | | | | | | | | | | | | | | | | | | | | | | | | | | | | | | |
| Blue - Black | 50.8 | | | | | | | | | | | | | | | | | | | | | | | | | | | | | | | | | | | | |
| Blue - White | | | | | | | | | | | | | | | | | | | | | | | | | | | | | | | | | | | | | |

<Thermistor Characteristic graph>

Thermistor for lower temperature

- Room temperature thermistor(TH21)
- Liquid pipe thermistor(TH22)
- Gas pipe temperature thermistor(TH23)
- Drain sensor(DS)

Thermistor $R_0=15k\Omega \pm 3\%$
 Fixed number of $B=3480k\Omega \pm 2\%$

$$R_t=15\exp \left\{ 3480 \left(\frac{1}{273+t} - \frac{1}{273} \right) \right\}$$

| | |
|------|-------|
| 0°C | 15kΩ |
| 10°C | 9.6kΩ |
| 20°C | 6.3kΩ |
| 25°C | 5.2kΩ |
| 30°C | 4.3kΩ |
| 40 | 3.0kΩ |

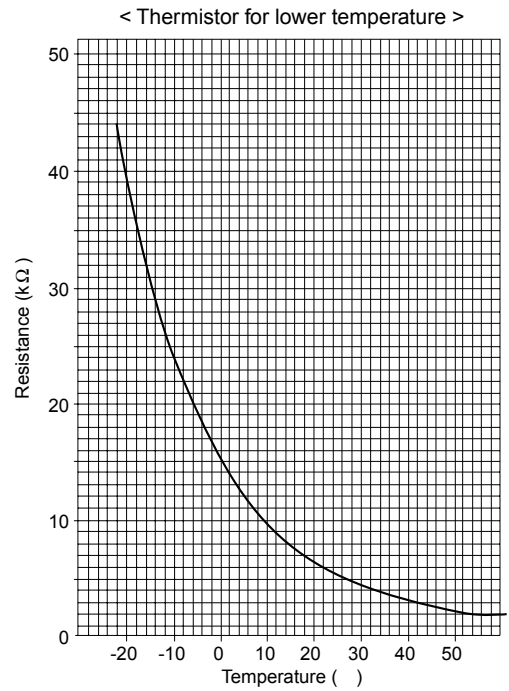

Linear expansion valve

① Operation summary of the linear expansion valve.

- Linear expansion valve open/close through stepping motor after receiving the pulse signal from the indoor controller board.
- Valve position can be changed in proportion to the number of pulse signal.

<Connection between the indoor controller board and the linear expansion valve>

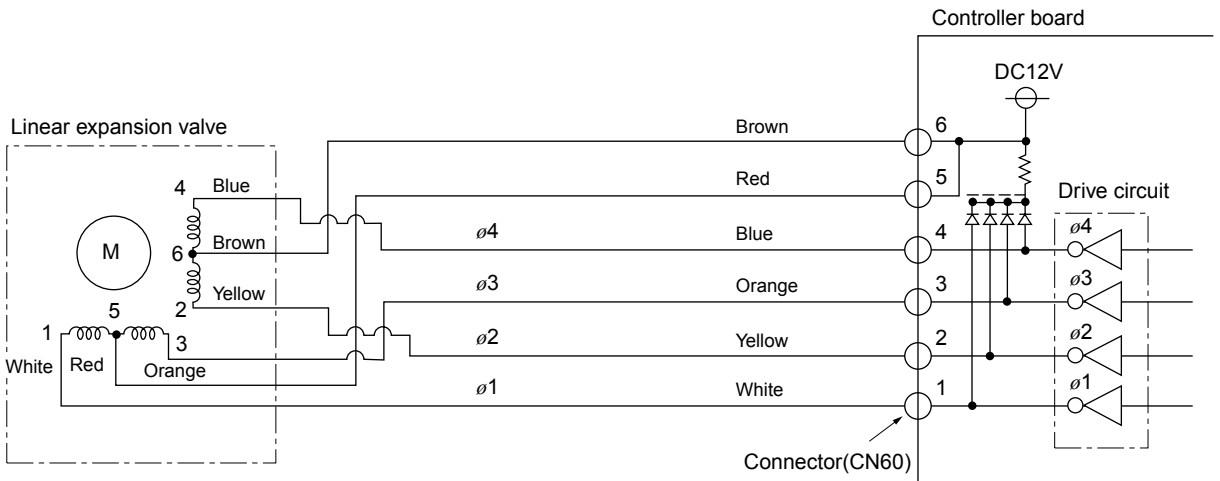

<Output pulse signal and the valve operation>

| Output (Phase) | Output | | | |
|----------------|--------|----------------------------------|-----|-----|
| | 1 | 2 | 3 | 4 |
| ø1 | ON | OFF | OFF | ON |
| ø2 | ON | ON | OFF | OFF |
| ø3 | OFF | ON | ON | OFF |
| ø4 | OFF | OFF </td <td>ON</td> <td>ON</td> | ON | ON |

Closing a valve : 1 \bar{O} 2 \bar{O} 3 \bar{O} 4 \bar{O} 1
 Opening a valve : 4 \bar{O} 3 \bar{O} 2 \bar{O} 1 \bar{O} 4

The output pulse shifts in above order.

1. When linear expansion valve operation stops, all output phase become OFF.
2. At phase interruption or when phase does not shift in order, motor does not rotate smoothly and motor will locks and vibrates.

Linear expansion valve operation

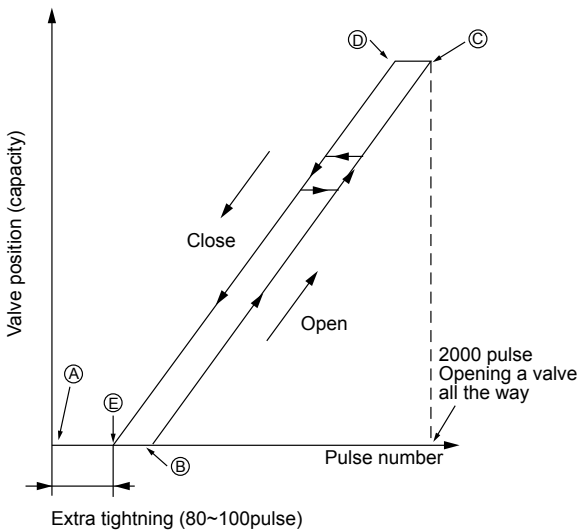

When the switch is turned on, 2200 pulse closing valve signal will be send till it goes to A point in order to define the valve position.

When the valve move smoothly, there is no noise or vibration occurring from the linear expansion valve : however, when the pulse number moves from E to A or when the valve is locked, more noise can be heard than normal situation.

Noise can be detected by placing the ear against the screw driver handle while putting the screw driver to the linear expansion valve.







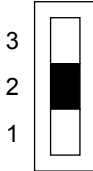
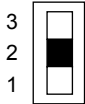
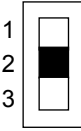
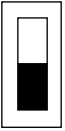

Trouble shooting

| Symptom | Check points | Countermeasures |
|--|--|--|
| Operation circuit failure of the micro processor. | Disconnect the connector on the controller board, then connect LED for checking. Pulse signal will be sent out for 10 seconds as soon as the main switch is turn on. If there is LED with lights on or lights off, it means the operation circuit is abnormal. | Exchange the indoor controller board at drive circuit failure. |
| Linear expansion valve mechanism is locked. | Motor will idle and make ticking noise when motor is operated while the linear expansion valve is locked. This ticking sound is the sign of the abnormality. | Exchange the linear expansion vale. |
| Short or breakage of the motor coil of the linear expansion valve. | Measure the resistance between the each coil (red-white, red-orange, brown-yellow, brown-blue) using a tester. It is normal if the resistance is in the range of $150\Omega \pm 10\%$. | Exchange the linear expansion valve. |
| Valve doesn't close completely (thermistor leaking). | To check the linear expansion valve, operate the indoor unit in fan mode and at the same time operate other indoor units in cooling mode, then check the pipe temperature <liquid pipe temperature> of the indoor unit by the outdoor multi controller board operation monitor. During fan operation, linear expansion valve is closed completely and if there are some leaking, detecting temperature of the thermistor will go lower. If the detected temperature is much lower than the temperature indicated in the remote controller, it means the valve is not closed all the way. It is not necessary to exchange the linear expansion valve, if the leakage is small and not making any trouble. | If large amount of refrigeration is leaked, exchange the linear expansion valve. |
| Wrong connection of the connector or contact failure. | Check the color of lead wire and missing terminal of the connector. | Disconnect the connector at the controller board, then check the continuity. |

7-2. Function of Dip-switch

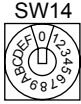
| Switch | Pole | Function | Operation by switch | | Remarks | | | | | | | | | | | | | | | | | | | | | | | | | | | | | |
|------------------------------------|------|--|---|-----------------------------------|---|----------------|--------|-----|----------------|--|----------------|--|----------------|--|----------------|--|----------------|--|----------------|--|----------------|--|----------------|--|----------------|--|----------------|--|----------------|--|----------------|--|--|--|
| | | | ON | OFF | | | | | | | | | | | | | | | | | | | | | | | | | | | | | | |
| SW1 Mode Selection | 1 | Thermistor<Intake temperature detection>position | Built-in remote controller | Indoor unit | <div style="border: 1px solid black; padding: 5px; width: fit-content;">Address board</div> <p><At delivery></p> | | | | | | | | | | | | | | | | | | | | | | | | | | | | | |
| | 2 | Filter crogging detection | Provided | Not provided | | | | | | | | | | | | | | | | | | | | | | | | | | | | | | |
| | 3 | Filter life | 2,500hr | 100hr | | | | | | | | | | | | | | | | | | | | | | | | | | | | | | |
| | 4 | Air intake | Effective | Not effective | | | | | | | | | | | | | | | | | | | | | | | | | | | | | | |
| | 5 | Remote indication switching | Thermostat ON signal indication | Fan output indication | | | | | | | | | | | | | | | | | | | | | | | | | | | | | | |
| | 6 | Humidifier control | Always operated while the heat is ON | Operated depends on the condition | | | | | | | | | | | | | | | | | | | | | | | | | | | | | | |
| | 7 | Air flow st | Low | Extra low | | | | | | | | | | | | | | | | | | | | | | | | | | | | | | |
| | 8 | Heat thermostat OFF | Setting air flow | Reset to SW1-7 | | | | | | | | | | | | | | | | | | | | | | | | | | | | | | |
| | 9 | Auto reset function | Effective | Not effective | | | | | | | | | | | | | | | | | | | | | | | | | | | | | | |
| | 10 | Power ON/OFF | Effective | Not effective | | | | | | | | | | | | | | | | | | | | | | | | | | | | | | |
| SW2 Capacity code setting | 1~6 | <table border="1" style="width: 100%; text-align: center;"> <thead> <tr> <th>MODELS</th> <th>SW2</th> <th>MODELS</th> <th>SW2</th> <th>MODELS</th> <th>SW2</th> </tr> </thead> <tbody> <tr> <td>PFFY-P20VLEM-A</td> <td></td> <td>PFFY-P25VLEM-A</td> <td></td> <td>PFFY-P32VLEM-A</td> <td></td> </tr> <tr> <td>PFFY-P40VLEM-A</td> <td></td> <td>PFFY-P50VLEM-A</td> <td></td> <td>PFFY-P63VLEM-A</td> <td></td> </tr> <tr> <td>PFFY-P20VLRM-A</td> <td></td> <td>PFFY-P25VLRM-A</td> <td></td> <td>PFFY-P32VLRM-A</td> <td></td> </tr> <tr> <td>PFFY-P40VLRM-A</td> <td></td> <td>PFFY-P25VLRM-A</td> <td></td> <td>PFFY-P63VLRM-A</td> <td></td> </tr> </tbody> </table> | MODELS | SW2 | MODELS | SW2 | MODELS | SW2 | PFFY-P20VLEM-A | | PFFY-P25VLEM-A | | PFFY-P32VLEM-A | | PFFY-P40VLEM-A | | PFFY-P50VLEM-A | | PFFY-P63VLEM-A | | PFFY-P20VLRM-A | | PFFY-P25VLRM-A | | PFFY-P32VLRM-A | | PFFY-P40VLRM-A | | PFFY-P25VLRM-A | | PFFY-P63VLRM-A | | <div style="border: 1px solid black; padding: 5px; width: fit-content;">Indoor controller board</div> <p>Set while the unit is off.</p> <p><At delivery></p> <p>Set for each capacity.</p> | |
| | | MODELS | SW2 | MODELS | SW2 | MODELS | SW2 | | | | | | | | | | | | | | | | | | | | | | | | | | | |
| | | PFFY-P20VLEM-A | | PFFY-P25VLEM-A | | PFFY-P32VLEM-A | | | | | | | | | | | | | | | | | | | | | | | | | | | | |
| | | PFFY-P40VLEM-A | | PFFY-P50VLEM-A | | PFFY-P63VLEM-A | | | | | | | | | | | | | | | | | | | | | | | | | | | | |
| | | PFFY-P20VLRM-A | | PFFY-P25VLRM-A | | PFFY-P32VLRM-A | | | | | | | | | | | | | | | | | | | | | | | | | | | | |
| PFFY-P40VLRM-A | | PFFY-P25VLRM-A | | PFFY-P63VLRM-A | | | | | | | | | | | | | | | | | | | | | | | | | | | | | | |
| SW3 Function Selection | 1 | Heat pump/Cool only | Cooling only | Heat pump | <div style="border: 1px solid black; padding: 5px; width: fit-content;">Indoor controller board</div> <p>Set while the unit is off.</p> <p><At delivery></p> <p>(Note) At cooling mode, each angle can be used only 1 hour.</p> | | | | | | | | | | | | | | | | | | | | | | | | | | | | | |
| | 2 | Louver | Available | Not available | | | | | | | | | | | | | | | | | | | | | | | | | | | | | | |
| | 3 | Vane | Available | Not available | | | | | | | | | | | | | | | | | | | | | | | | | | | | | | |
| | 4 | Vane swing function | Available | Not available | | | | | | | | | | | | | | | | | | | | | | | | | | | | | | |
| | 5 | Vane horizontal angle | Second setting | First setting | | | | | | | | | | | | | | | | | | | | | | | | | | | | | | |
| | 6 | Vane cooling limit angle setting | Horizontal angle | Down blow | | | | | | | | | | | | | | | | | | | | | | | | | | | | | | |
| | 7 | — | — | — | | | | | | | | | | | | | | | | | | | | | | | | | | | | | | |
| | 8 | Heating 4deg up | Not effective | Effective | | | | | | | | | | | | | | | | | | | | | | | | | | | | | | |
| SW4 Unit Selection | 1~4 | <p><At delivery></p> | <div style="border: 1px solid black; padding: 5px; width: fit-content;">Indoor controller board</div> <p>Set while the unit is off.</p> | | | | | | | | | | | | | | | | | | | | | | | | | | | | | | | |

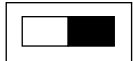
Note :The DipSW setting is effective during unit stopping (remote controller OFF) for SW1,2,3 and 4 commonly and the power source is not required to reset.

| Switch | Pole | Operation by switch | Remarks |
|--|---------------|---|---|
| SWA Option Note:1 | 1~3 |  <p>As this switch is used by interlocking with SWC, refer to the item of SWC for detail</p> | <div style="border: 1px solid black; padding: 2px; text-align: center;">Address board</div> <p><At delivery></p>  |
| SWC Option Note:1 | 2 |  <p>“オプション” (Option)</p>  <p>“標準” (Standard)</p> <p>(SWA) SWC</p> <p>When attach the optional high performance filter elements (filter casement) to the unit, be sure to attach it to the option side in order to prevent the air-flow reducing.</p> | <div style="border: 1px solid black; padding: 2px; text-align: center;">Address board</div> <p><At delivery></p> <p>“オプション” (Option)</p>  <p>“標準” (Standard)</p> |
| SW11 1st digit address setting SW12 2nd digit address setting Note:2 | Rotary switch |  <p>SW12 SW11</p> <p>10 1</p> <p>Address setting should be done when network remote controller (PAR-F25MA) is being used.</p> | <div style="border: 1px solid black; padding: 2px; text-align: center;">Address board</div> <p>Address can be set while the unit is stopped.</p> <p><At delivery></p>   |
| SW14 Connect ion No. setting Note:2 | Rotary switch |  <p>SW14</p> <p>This is the switch to be used when the indoor unit is operated with R2 series outdoor unit as a set.</p> | <div style="border: 1px solid black; padding: 2px; text-align: center;">Address board</div> <p><At delivery></p>  |
| SW5 Voltage Selection Note:2 | 2 |  <p>220V 240V</p> <p>If the unit is used at the 230V or 240V area, set the voltage to 240V. If the unit is used at the 220V, set the voltage to 220V.</p> | <div style="border: 1px solid black; padding: 2px; text-align: center;">Address board</div> <p><At delivery></p> <p>220V 240V</p>  |

Note 1:The DipSW setting is effective always after powering (remote controller ON) for SWA and SWC.
2:The DipSW setting is effective during unit stopping (remote controller OFF) for SW11,12,14 and 5

8

DISASSEMBLY PROCEDURE

8-1 CONTROL BOX (Exposed type PFFY-P-VLEM)

Be careful removing heavy parts.

OPERATING PROCEDURE

1.Removing the front panel (A)

(1)Remove the fixing screws(two) of the front panel(A).(Fig.1)

(2)Hold the bottom of the front panel with your hands,and gently lift it. The front panel should fall down forward.(Fig.2)

2.Removing the control box cover (B)

(1)Remove the fixing screws(two) of the cover(B) and remove the cover.(Fig.3)

PHOTOS

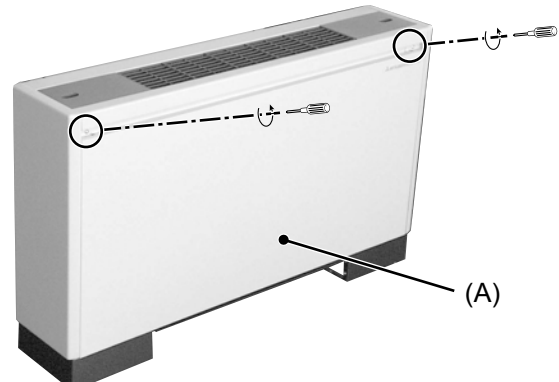

Fig.1

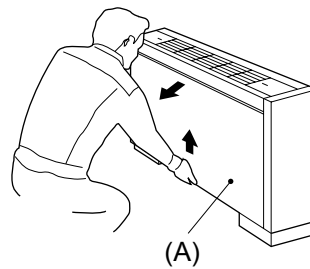

Fig.2

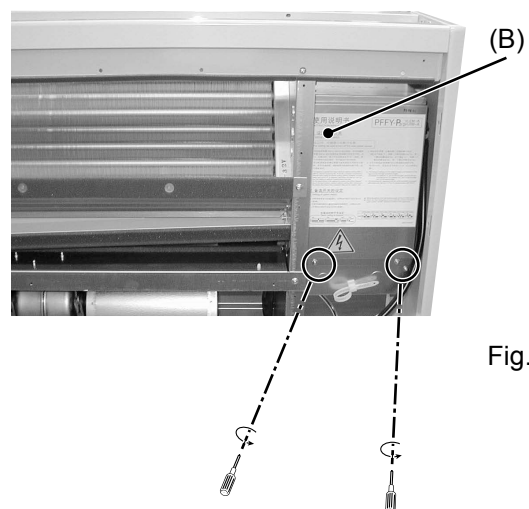
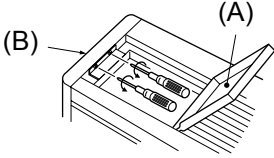
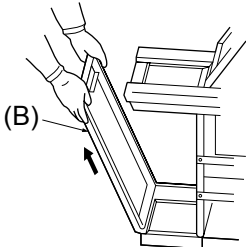
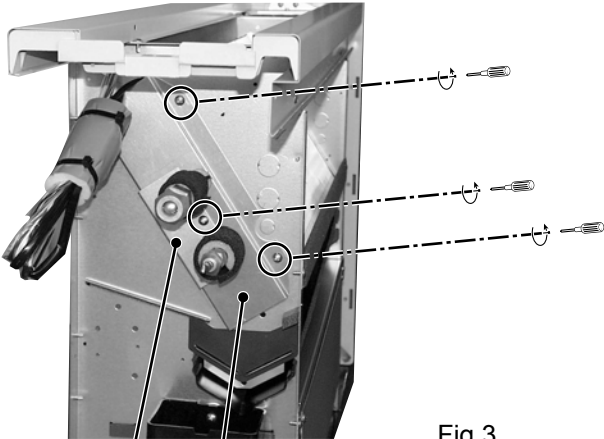
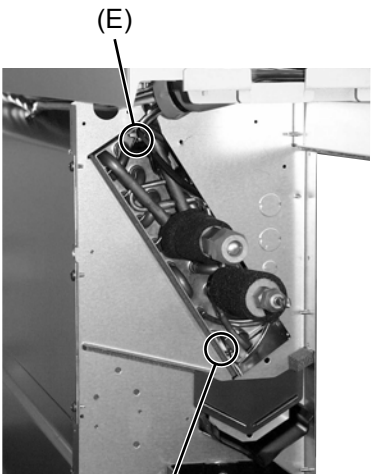



Fig.3

8-2 THERMISTOR (Gus and liquid piping temperature detection)



| OPERATING PROCEDURE | PHOTOS |
|--|--|
| <p>1.Removing the side casing</p> <p>(1)Open the control panel cover(A), remove the fixing screws(two) of the securing cover. (Fig. 1)</p> <p>(2)Pull up the side casing(B). (Fig. 2)</p> |  <p>Fig.1</p>  <p>Fig.2</p> |
| <p>2.Removing the thermistor</p> <p>(1)Remove the fixing screws (three), remove the cover (C) and (D). (Fig. 3)</p> <p>(2)Remove the thermistor (gas)(E) and the thermistor (liquid)(F). (Fig. 4)</p> |  <p>Fig.3</p> <p>(C) (D)</p> |
| |  <p>Fig.4</p> <p>(E) (F)</p> |

8-3 THERMISTOR (Intake air temperature detection)

Be careful

| OPERATING PROCEDURE | PHOTOS |
|---|---|
| <p>1.Removing the thermistor (1)Remove the thermistor under the control box.</p> |  <p>Thermistor</p> <p>Fig.1</p> |

8-4 DRAINPAN

| OPERATING PROCEDURE | PHOTOS |
|--|---|
| <p>1.Removing the drainpan (1)Remove the fixing screw of the side frame by the control box. (Fig. 1) (2)Slide the drainpan in the direction of the arrow A.</p> |  <p>Fig.1</p>  <p>Fig.2</p> |

8-5 FAN and FAN MOTOR

OPERATING PROCEDURE

1.Sliding the fan section (Fig.1)

- (1)Remove the fixing screws(two) (a).
- (2)Slide the fan section in direction of the arrow A.

2.Removing the fan motor (Fig.2)

- (1)Remove the fixing screws (two)(b) of the fan casing(A).
- (2)Remove the fan motor shaft fixing screw and remove the fan casing(A) and sirroco fan.
- (3)Remove the fixing screws(two) (c) of the motor fixtures (two) and remove the motor.

Notice:In case of the Model(PFFY-P32~63) stick out the motor shafts on both side of the motor.

PHOTOS

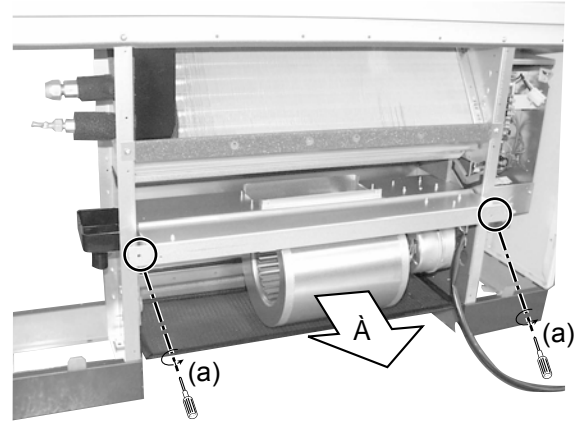

Fig.1

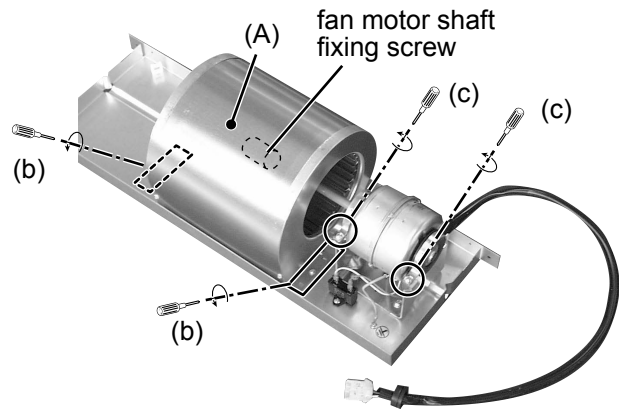

Fig.2

8-6 HEAT EXCHANGER

OPERATING PROCEDURE

1.Removing the casing

(1)Remove the fixing screws(six) and remove the casing. (Fig. 1)

2.Removing the cover1,2 with procedure 8-2

(Fig. 2)

3.Removing the Heat exchanger

(1)Remove the fixing screws(four) and remove the heat exchanger support. (Fig. 3)

(2)Remove the heat exchanger, moving from side to side.

PHOTOS

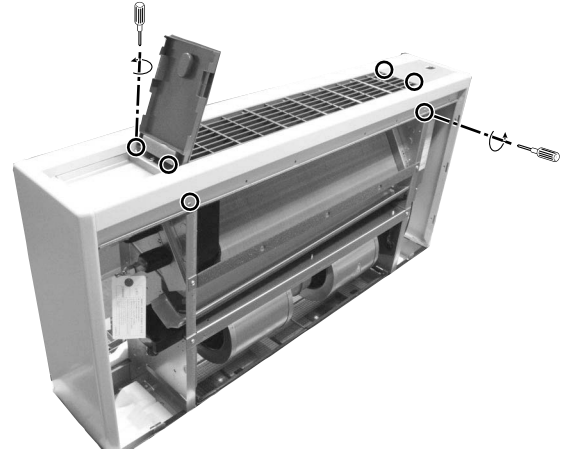

Fig.1

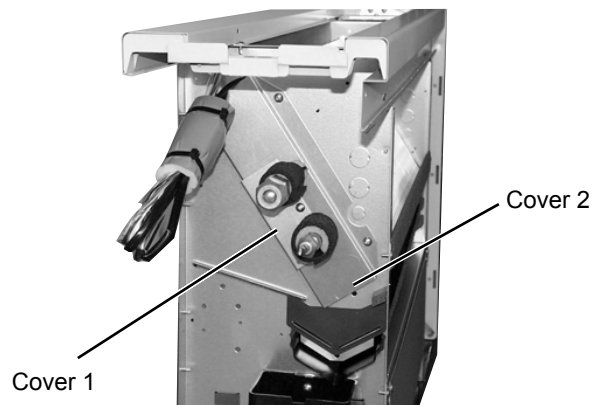

Fig.2

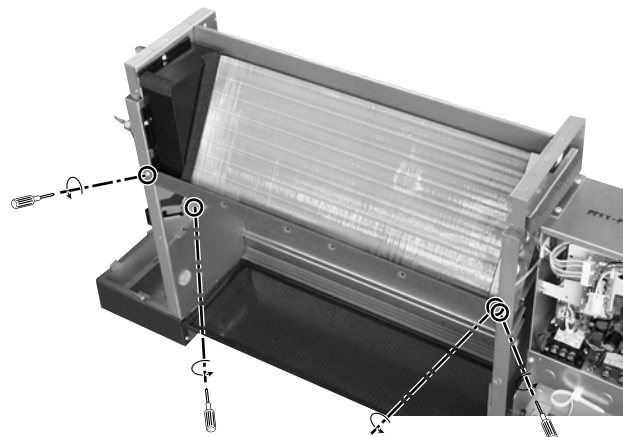

Fig.3

8-7 CASING (Concealed type PFFY-P-VLRM)

OPERATING PROCEDURE

1.Removing the casing ass'y

(1)Remove the fixing screws (nine) of the plate(A) and remove the plate. (Fig. 1)

2.Removing the air diffuser ass'y

(1)Remove the fixing screws (eight) of the air diffuser ass'y(B) and remove it. (Fig. 2)

Note: Without this section, almost the disassembly procedures are same as Exposed type (PFFY-P-VLEM) and Concealed type (PFFY-P-VLRM).

PHOTOS

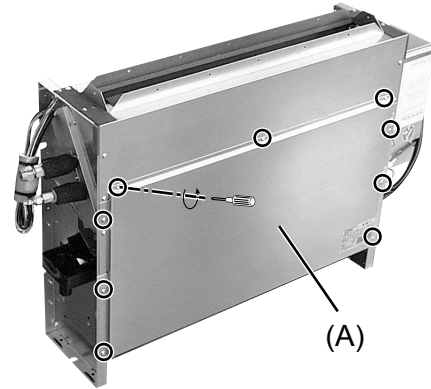

Fig.1

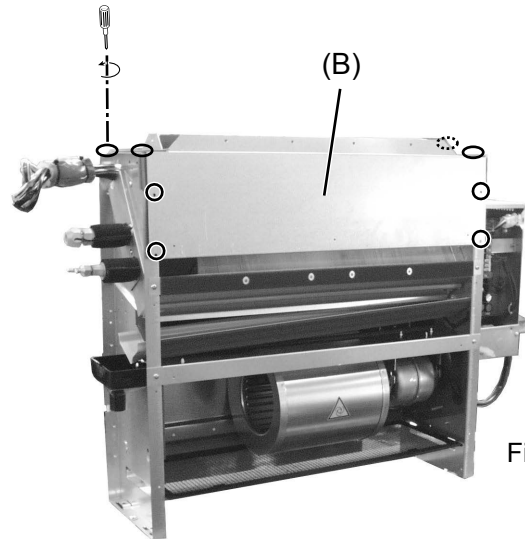

Fig.2

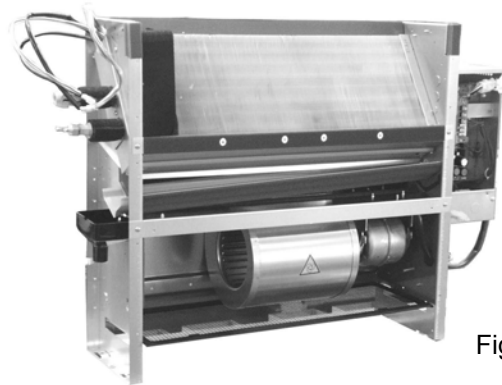

Fig.3



HEAD OFFICE: MITSUBISHI DENKI BLDG., 2-2-3, MARUNOUCHI, CHIYODA-KU, TOKYO 100-8310, JAPAN
