

**2019**

**R410A**

# TECHNICAL & SERVICE MANUAL

**Series PEFY** Ceiling Concealed (Fresh Air Intake type)

Model name

<Indoor unit>

**PEFY-P125VMHS-E-F**

**PEFY-P200VMHS-E-F**

**PEFY-P250VMHS-E-F**

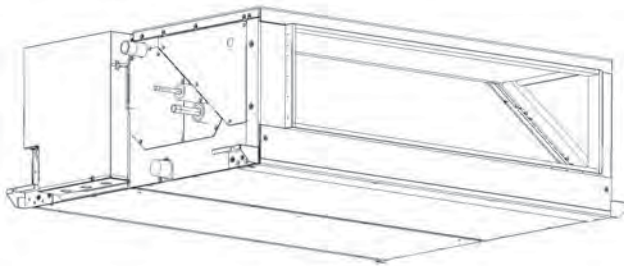

Indoor unit

**3rd edition**

# CITY MULTI

# Safety Precautions

## Read before installation and performing electrical work

- Thoroughly read the following safety precautions prior to installation.
- Observe these safety precautions for your safety.
- This equipment may have adverse effects on the equipment on the same power supply system.
- Contact the local power authority before connecting to the system.

### Symbol explanations

#### WARNING

This symbol indicates that failure to follow the instructions exactly as stated poses the risk of serious injury or death.

#### CAUTION

This symbol indicates that failure to follow the instructions exactly as stated poses the risk of serious injury or damage to the unit.



Indicates an action that must be avoided.



Indicates important instructions.



Indicates a parts that requires grounding.



Indicates that caution must be taken with rotating parts. (This symbol is on the main unit label.) <Color: Yellow>



Indicates that the parts that are marked with this symbol pose a risk of electric shock. (This symbol is on the main unit label.) <Color: Yellow>

#### WARNING

Carefully read the labels affixed to the main unit.

#### WARNING

- Ask your dealer or a qualified technician to install the unit.**
  - Improper installation by the user may result in water leakage, electric shock, or fire.
- Properly install the unit on a surface that can withstand its weight.**
  - Unit installed on an unstable surface may fall and cause injury.
- Only use specified cables. Securely connect each cable so that the terminals do not carry the weight of the cable.**
  - Improperly connected cables may produce heat and start a fire.
- Take appropriate safety measures against wind gusts and earthquakes to prevent the unit from toppling over.**
  - Improper installation may cause the unit to topple over and cause injury or damage to the unit.
- Only use accessories (i.e., air cleaners, humidifiers, electric heaters) recommended by Mitsubishi Electric.**
- Do not make any modifications or alterations to the unit. Consult your dealer for repair.**
  - Improper repair may result in water leakage, electric shock, or fire.
- Do not touch the heat exchanger fins with bare hands.**
  - The fins are sharp and pose a risk of cuts.
- In the event of a refrigerant leak, thoroughly ventilate the room.**
  - If gaseous refrigerant leaks out and comes in contact with an open flame, toxic gases will be generated.
- Properly install the unit according to the instructions in the Installation Manual.**
  - Improper installation may result in water leakage, electric shock, or fire.
- Have all electrical work performed by an authorized electrician according to the local regulations and the instructions in this manual. Use a dedicated circuit.**
  - Insufficient power supply capacity or improper installation of the unit may result in malfunctions of the unit, electric shock, or fire.
- Disconnect all electric power supplies before accessing of electric parts (inner of control box, fan motor, drain pump etc.)**
  - Touching electric parts result in electric shock.
- Keep electrical parts away from water.**
  - Wet electrical parts pose a risk of electric shock, smoke, or fire.

- Securely attach the control box cover.**

- If the cover is not installed properly, dust or water may infiltrate and pose a risk of electric shock, smoke, or fire.

- Only use the type of refrigerant that is indicated on the unit when installing or relocating the unit.**

- Infiltration of any other types of refrigerant or air into the unit may adversely affect the refrigerant cycle and may cause the pipes to burst or explode.

- When installing the unit in a small space, take appropriate precautions to prevent leaked refrigerant from reaching the limiting concentration.**

- Leaked refrigerant gas will displace oxygen and may cause oxygen starvation. Consult your dealer before installing the unit.

- Consult your dealer or a qualified technician when moving or reinstalling the unit.**

- Improper installation may result in water leakage, electric shock, or fire.

- After completing the service work, check for a refrigerant leak.**

- If leaked refrigerant is exposed to a heat source, such as a fan heater, stove, or electric grill, toxic gases will be generated.

- Do not try to defeat the safety features of the unit.**

- Forced operation of the pressure switch or the temperature switch by defeating the safety features for these devices, or the use of accessories other than the ones that are recommended by Mitsubishi Electric may result in smoke, fire, or explosion.

- Consult your dealer for proper disposal method.**

- Do not use a leak detection additive.**

### Precautions for handling units for use with R410A

#### CAUTION

- Do not use the existing refrigerant piping.**

- A large amount of chlorine that may be contained in the residual refrigerant and refrigerator oil in the existing piping may cause the refrigerator oil in the new unit to deteriorate.

- Use refrigerant piping materials made of phosphorus deoxidized copper. Keep the inner and outer surfaces of the pipes clean and free of such contaminants as sulfur, oxides, dust, dirt, shaving particles, oil, and moisture.**

- Contaminants in the refrigerant piping may cause the refrigerator oil to deteriorate.

- Store the piping materials indoors, and keep both ends of the pipes sealed until immediately before brazing. (Keep elbows and other joints wrapped in plastic.)**

- Infiltration of dust, dirt, or water into the refrigerant system may cause the refrigerator oil to deteriorate or cause the compressor to malfunction.

- Use a small amount of ester oil, ether oil, or alkyl benzene to coat flares and flanges.**

- Infiltration of a large amount of mineral oil may cause the refrigerator oil to deteriorate.

- Charge the system with refrigerant in the liquid phase.**

- If gaseous refrigerant is drawn out of the cylinder first, the composition of the remaining refrigerant in the cylinder will change and become unsuitable for use.

- Only use R410A.**

- The use of other types of refrigerant that contain chloride may cause the refrigerator oil to deteriorate.

- Use a vacuum pump with a check valve.**

- If a vacuum pump that is not equipped with a check valve is used, the vacuum pump oil may flow into the refrigerant cycle and cause the refrigerator oil to deteriorate.

- Prepare tools for exclusive use with R410A. Do not use the following tools if they have been used with the conventional refrigerant: gauge manifold, charging hose, gas leak detector, check valve, refrigerant charge base, vacuum gauge, and refrigerant recovery equipment.**

- If the refrigerant or the refrigerator oil that may be left on these tools are mixed in with R410A, it may cause the refrigerator oil in the new system to deteriorate.

- Infiltration of water may cause the refrigerator oil to deteriorate.

- Leak detectors for conventional refrigerants will not detect an R410A leak because R410A is free of chlorine.

---

♦**Do not use a charging cylinder.**

- If a charging cylinder is used, the composition of the refrigerant in the cylinder will change and become unsuitable for use.

♦**Exercise special care when handling tools for use with R410A.**

- Infiltration of dust, dirt, or water into the refrigerant system may cause the refrigerator oil to deteriorate.

# CONTENTS

---

## I Features

[1] Features.....	1
-------------------	---

## II Part Names and Functions

[1] Part Names and Functions .....	2
1. Indoor (main) unit.....	2
2. Remote controller .....	3

## III Specification

[1] Specification .....	5
1. Specification .....	5
2. Electrical parts specifications.....	6

## IV Outlines and Dimensions

[1] Outlines and Dimensions .....	7
-----------------------------------	---

## V Wiring Diagram

[1] Wiring Diagram .....	11
--------------------------	----

## VI Refrigerant System Diagram

[1] Refrigerant System Diagram .....	13
--------------------------------------	----

## VII Troubleshooting

[1] Troubleshooting .....	14
1. Check methods.....	14
2. DC fan motor (fan motor/indoor control board).....	18
3. Setting of address switch.....	19
4. Voltage test points on the control board .....	20
5. Setting of dip-switch (at delivery).....	21
6. Function setting .....	21
7. Selecting the airflow rate mode and external static pressure .....	22
8. Enabling the function to prevent cold draft (during heating operation) .....	23
9. Setting addresses .....	23
10. Function the LED of the indoor unit service board.....	23

## VIII Disassembly Procedure

[1] Disassembly Procedure (PEFY-P125VMHS-E-F) .....	24
1. Control box .....	24
2. Fan and fan motor .....	25
3. LEV, thermistor (Liquid/Gas piping temperature detection).....	26
4. Heat exchanger .....	27
5. Control box inside layout .....	29
6. Sensor position .....	30
[2] Disassembly Procedure (PEFY-P200, 250VMHS-E-F) .....	31
1. Control box .....	31
2. Fan and fan motor .....	32
3. LEV, thermistor (Liquid/Gas piping temperature detection).....	34
4. Heat exchanger .....	35
5. Control box inside layout .....	37
6. Sensor position .....	38



---

**[1] Features**

---

# Series PEFY Ceiling Concealed

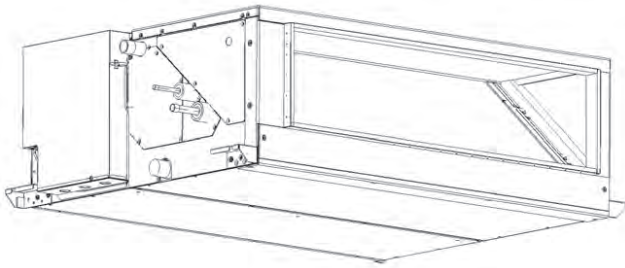

Indoor unit

Model	Cooling capacity/Heating capacity
	kW
PEFY-P125VMHS-E-F	14.0/8.9
PEFY-P200VMHS-E-F	22.4/13.9
PEFY-P250VMHS-E-F	28.0/17.4

---

**[1] Part Names and Functions**

---

**1. Indoor (main) unit**

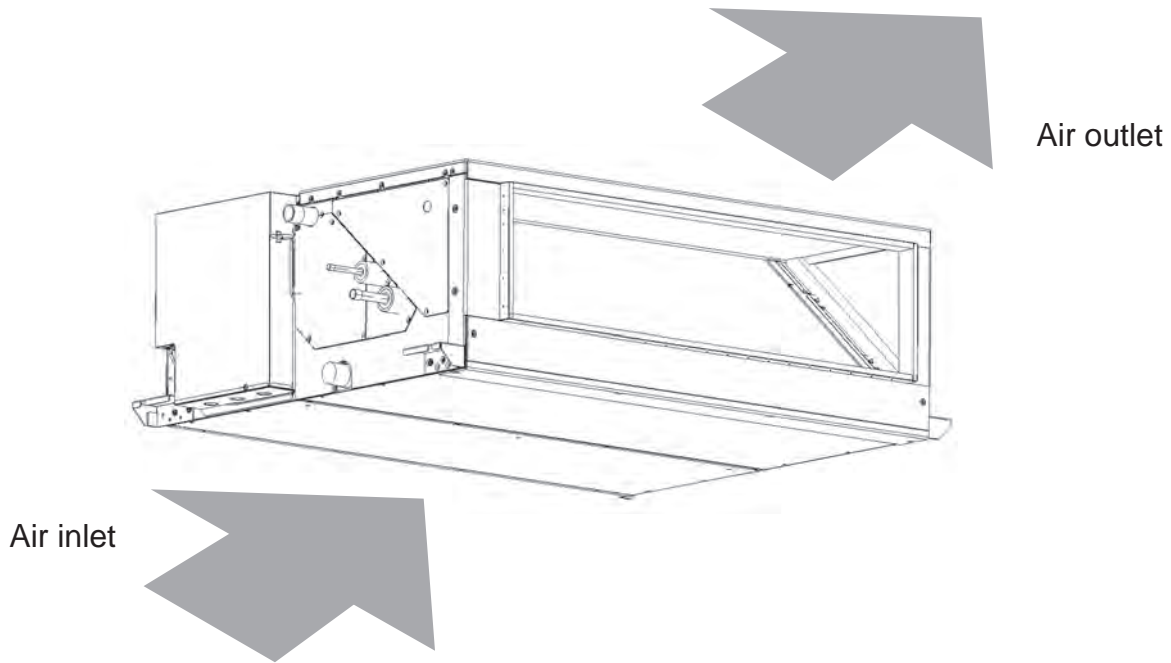

## 2. Remote controller

[PAR-32MAA]

Once the operation mode is selected, the unit will remain in the selected mode until changed.

### (1) Remote Controller Buttons

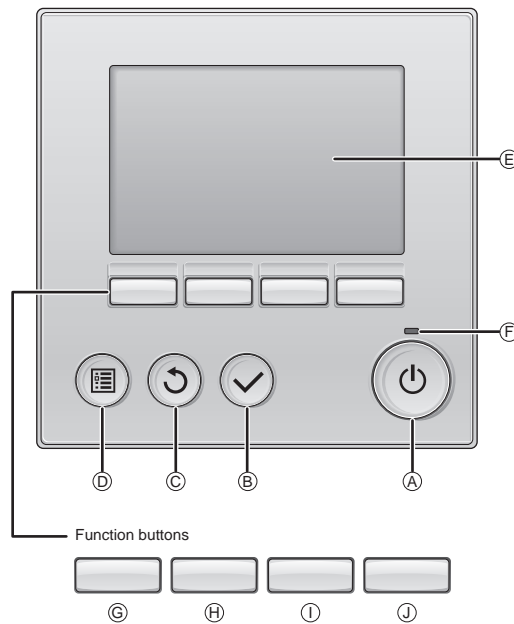

#### (A) [ON/OFF] button

Press to turn ON/OFF the indoor unit.

#### (B) [SELECT] button

Press to save the setting.

#### (C) [RETURN] button

Press to return to the previous screen.

#### (D) [MENU] button

Press to bring up the Main menu.

#### (E) Backlit LCD

Operation settings will appear.

When the backlight is off, pressing any button turns the backlight on and it will stay lit for a certain period of time depending on the screen.

When the backlight is off, pressing any button turns the backlight on and does not perform its function. (except for the [ON/OFF] button)

#### (F) ON/OFF lamp

This lamp lights up in green while the unit is in operation. It blinks while the remote controller is starting up or when there is an error.

The functions of the function buttons change depending on the screen. Refer to the button function guide that appears at the bottom of the LCD for the functions they serve on a given screen.

When the system is centrally controlled, the button function guide that corresponds to the locked button will not appear.

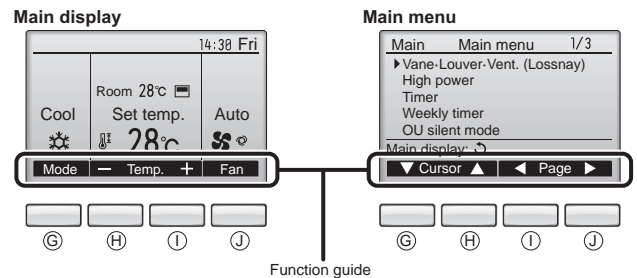

#### (G) Function button [F1]

Main display: Press to change the operation mode.  
Main menu: Press to move the cursor down.

#### (H) Function button [F2]

Main display: Press to decrease temperature.  
Main menu: Press to move the cursor up.

#### (I) Function button [F3]

Main display: Press to increase temperature.  
Main menu: Press to go to the previous page.

#### (J) Function button [F4]

Main display: Press to change the fan speed.  
Main menu: Press to go to the next page.



(2) Remote Controller Display

The main display can be displayed in two different modes: "Full" and "Basic."  
 The factory setting is "Full." To switch to the "Basic" mode, change the setting on the "Main display" setting screen (Main menu > Initial setting > Main display).

**Full mode**

\* All icons are displayed for explanation.

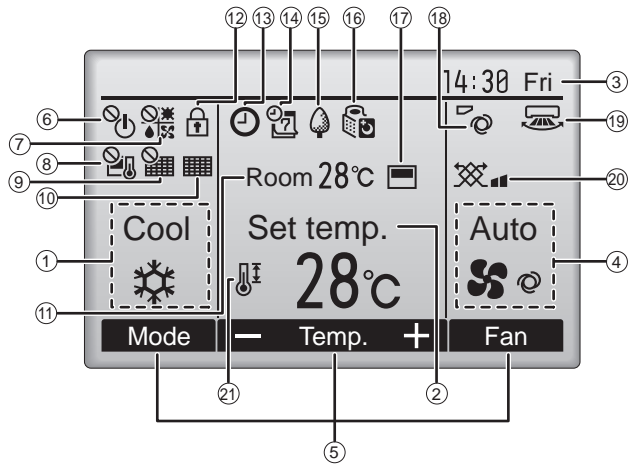

**Basic mode**

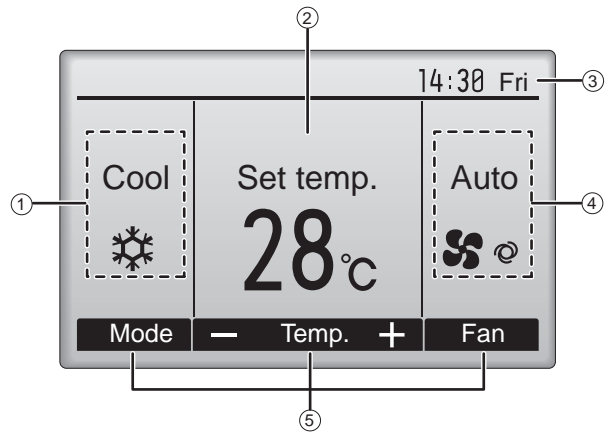

- ① Operation mode**  
Indoor unit operation mode appears here.
- ② Set temperature**  
Set temperature appears here.
- ③ Clock**  
Current time appears here.
- ④ Fan speed**  
Fan speed setting appears here.
- ⑤ Button function guide**  
Functions of the corresponding buttons appear here.
- ⑥**   
Appears when the ON/OFF operation is centrally controlled.
- ⑦**   
Appears when the operation mode is centrally controlled.
- ⑧**   
Appears when the set temperature is centrally controlled.
- ⑨**   
Appears when the filter reset function is centrally controlled.
- ⑩**   
Indicates when filter needs maintenance.
- ⑪ Room temperature**  
Current outlet air temperature appears here.
- ⑫**   
Appears when the buttons are locked.
- ⑬**   
Appears when the On/Off timer, Night setback, or Auto-off timer function is enabled.  
  
 appears when the timer is disabled by the centralized control system.
- ⑭**   
Appears when the Weekly timer is enabled.

- ⑮**   
Appears while the units are operated in the energy-save mode. (Will not appear on some models of indoor units)
- ⑯**   
Appears while the outdoor units are operated in the silent mode.
- ⑰**   
Appears when the built-in thermistor on the remote controller is activated to monitor the room temperature (⑪).
- ⑱**   
Appears when the thermistor on the indoor unit is activated to monitor the room temperature.
- ⑲**   
Indicates the vane setting.
- ⑳**   
Indicates the louver setting.
- ㉑**   
Indicates the ventilation setting.
- ㉒**   
Appears when the set temperature range is restricted.

Most settings (except ON/OFF, mode, fan speed, temperature) can be made from the Main menu.

**[1] Specification****1. Specification**

Model name			PEFY-P125VMHS-E-F	PEFY-P200VMHS-E-F	PEFY-P250VMHS-E-F	
Power source			1-phase 220-240V 50Hz/60Hz			
Cooling capacity <sup>*1</sup>		kW	14.0	22.4	28.0	
Heating capacity <sup>*1</sup>			8.9	13.9	17.4	
Power consumption	Cooling	kW	0.22	0.26	0.35	
	Heating		0.23	0.27	0.36	
Current	Cooling	A	1.43	1.66	2.16	
	Heating		1.52	1.85	2.38	
External finish			Galvanizing			
Dimension	Height	mm	380	470		
	Width		1195	1250		
	Depth		900	1120		
Net weight		kg	49	78	81	
Heat exchanger			Cross fin (aluminum plate fin and copper tube)			
Fan	Type x Quantity		Sirocco fan x 1	Sirocco fan x 2		
	Airflow rate (Lo-Mid-Hi)	High-airflow rate mode	m <sup>3</sup> /min	15.5-18.0-20.0	25.0-28.0-32.0	31.0-35.0-40.0
		Normal-airflow rate mode		14.0-15.5-18.0	22.5-25.0-28.0	28.0-31.0-35.0
External static pressure <sup>*2</sup>		Pa	100/150/200/250			
Motor	Type		DC motor			
	Output		kW	0.244	0.375	
Air filter (option)			Synthetic fiber unwoven cloth filter (long life)			
Refrigerant pipe diameter	Gas (Brazed)	mm	ø 15.88	ø 19.05	ø 22.2	
	Liquid (Brazed)	mm	ø 9.52			
Drain pipe dimension		mm	32 (1-1/4 inch)			
Noise level (Lo-Mid-Hi)	High-airflow rate mode	dB (A)	36-40-42	36-39-42	38-41-45	
	Normal-airflow rate mode		34-37-41	35-38-41	38-40-44	

\*1 Cooling/Heating capacity indicates the maximum value at operation under the following condition.

Cooling: Indoor 33°CDB/28°CWB, Outdoor 33°CDB. The set temperature of the remote controller is 18°C.

Heating: Indoor 0°CDB/-2.9°CWB, Outdoor 0°CDB/-2.9°CWB. The set temperature of the remote controller is 25°C.

\*2 The external static pressure is set to 200Pa at factory shipment.

## 2. Electrical parts specifications

Parts name \ model	Symbol	PEFY-P125VMHS-E-F	PEFY-P200VMHS-E-F	PEFY-P250VMHS-E-F
Outlet air temperature thermistor	TH21	Resistance 0°C/15kΩ, 10°C/9.6kΩ, 20°C/6.3kΩ, 25°C/5.4kΩ, 30°C/4.3kΩ, 40°C/3.0kΩ		
Liquid pipe thermistor	TH22	Resistance 0°C/15kΩ, 10°C/9.6kΩ, 20°C/6.3kΩ, 25°C/5.4kΩ, 30°C/4.3kΩ, 40°C/3.0kΩ		
Gas pipe thermistor	TH23	Resistance 0°C/15kΩ, 10°C/9.6kΩ, 20°C/6.3kΩ, 25°C/5.4kΩ, 30°C/4.3kΩ, 40°C/3.0kΩ		
Inlet air temperature thermistor	TH24	Resistance 0°C/15kΩ, 10°C/9.6kΩ, 20°C/6.3kΩ, 25°C/5.4kΩ, 30°C/4.3kΩ, 40°C/3.0kΩ		
Fuse	FUSE	250 VAC 6.3A		
Fan motor (with inner thermostat)	MF1, 2	8-pole, output 244W SIC-101CW-D8244-4	10-pole, output 375W KMUC4E2MW or KMUC4E3MW	
Linear expansion valve	LEV	12 VDC Stepping motor drive		
Power supply terminal bed	TB2	(L, N, ⊕) 250V 20A		
Transmission terminal bed	TB5 TB15	(M1, M2, S) 250V 20A (1, 2) 250V 15A		

**[1] Outlines and Dimensions**

1. PEFY-P125VMHS-E-F

Unit: mm

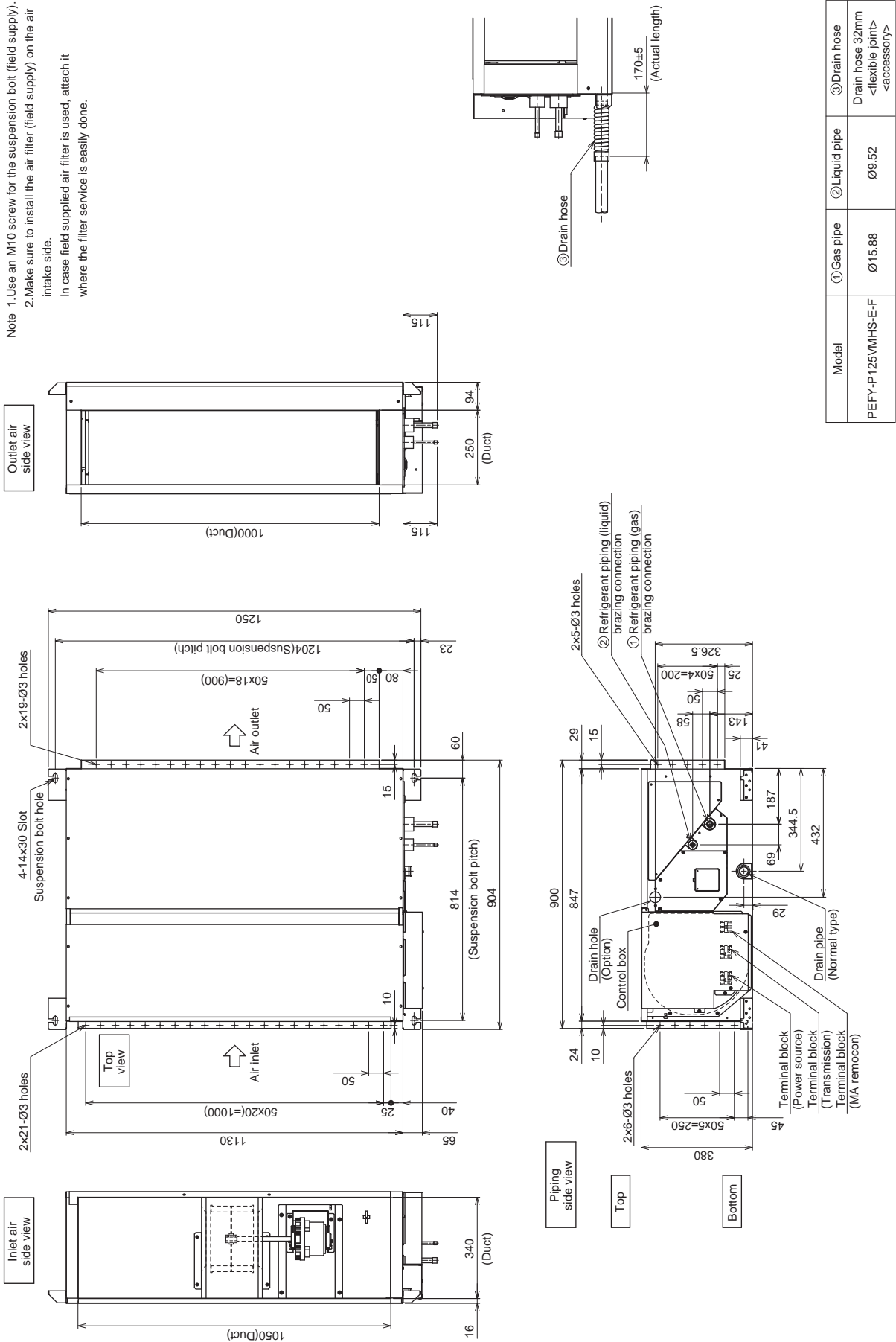

[Maintenance access space]

Secure enough access space to allow for the maintenance, inspection, and replacement of the motor, fan, heat exchanger, drain pan and control box in one of the following ways.

Select an installation site for the indoor unit so that its maintenance access space will not be obstructed by beam or other objects.

Create access door 1 (450x450mm) for the maintenance from the unit side when the thermostat, LEV and control box is exchanged. (Fig.2,4)

(1) When a space of 300mm or more is available below the unit between the unit and the ceiling.

Create access door 2 (600x600mm) for the maintenance from the bottom when the motor, fan, heat exchanger and drain pan is cleaned (exchanged). (Fig.2)

(2) When a space of less than 300mm is available below the unit between the unit and the ceiling.

(At least 20mm of space should be left below the unit as shown in Fig.3.)

Create access door 3 for the maintenance from the bottom when the motor, fan, heat exchanger and drain pan is cleaned (exchanged). (Fig.4)

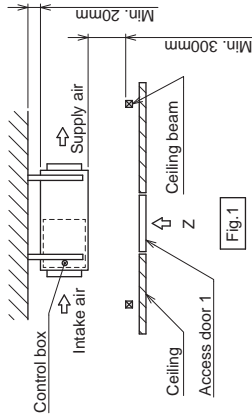

Fig.1

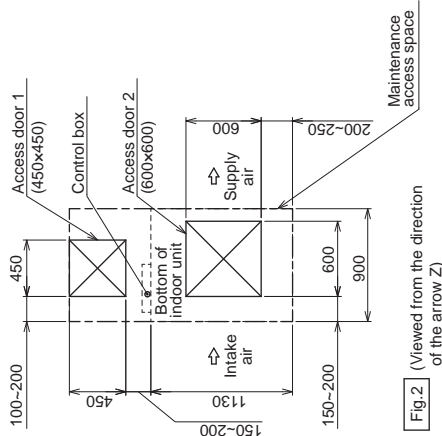

Fig.2 (Viewed from the direction of the arrow Z)

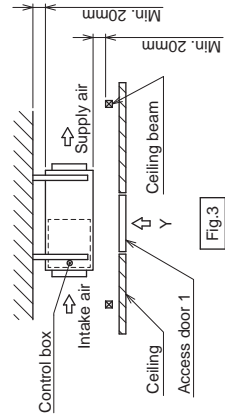

Fig.3

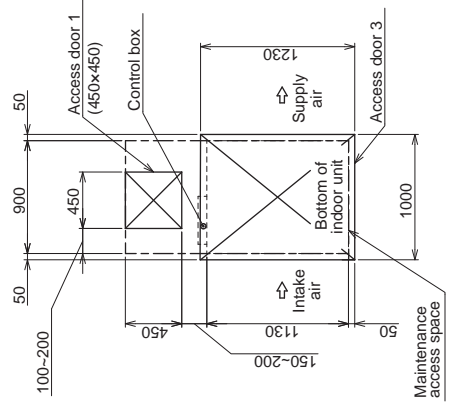
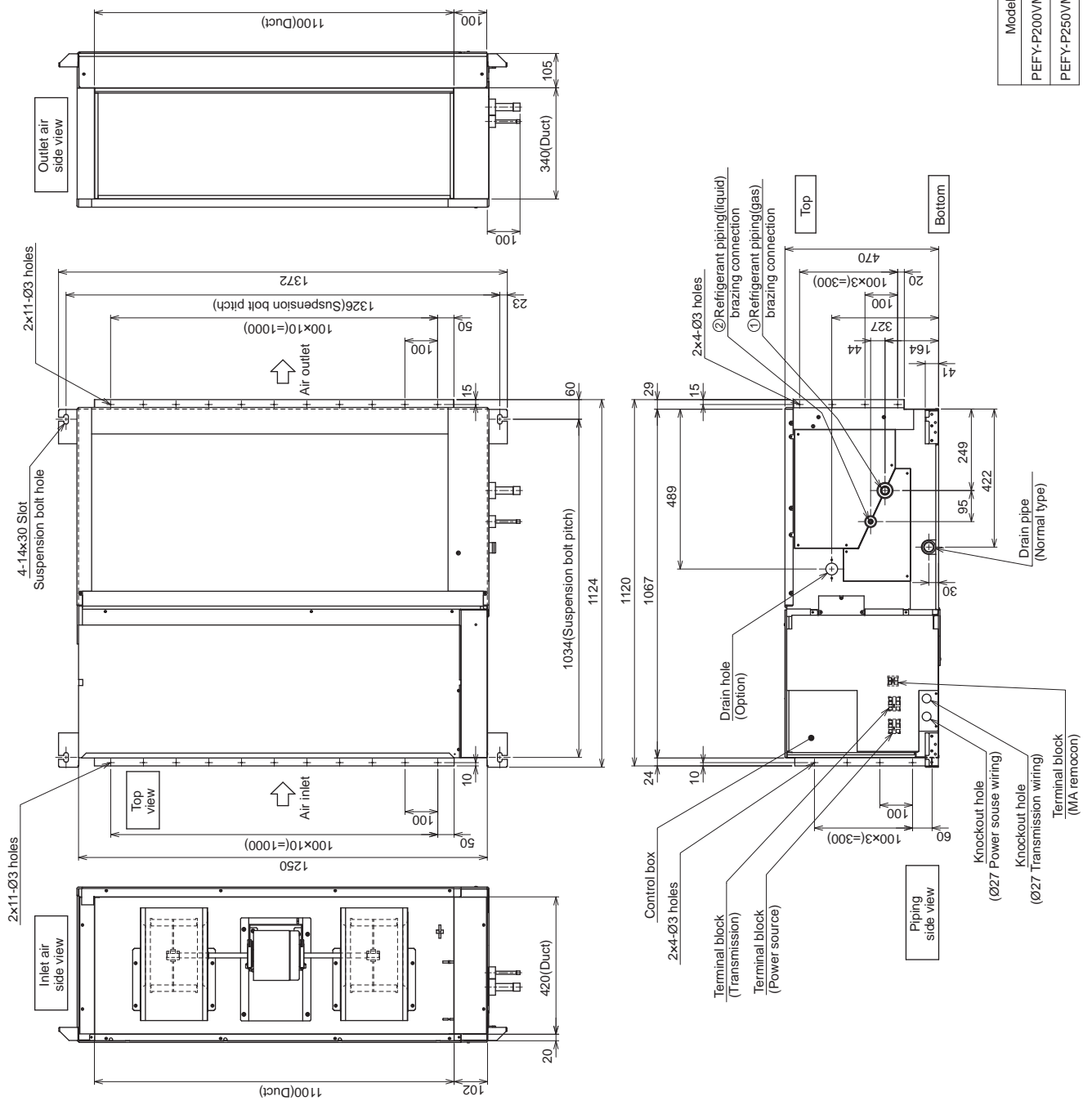

Fig.4 (Viewed from the direction of the arrow Y)

2. PEFY-P200, 250VMHS-E-F

Unit: mm

Note 1. Use an M10 screw for the suspension bolt (field supply).  
 2. Make sure to install the air filter (field supply) on the air intake side.  
 In case field supplied air filter is used, attach it where the filter service is easily done.



Model	① Gas pipe	② Liquid pipe	③ Drain hose
PEFY-P200VMHS-E-F	Ø19.05	Ø9.52	Drain hose 32mm
PEFY-P250VMHS-E-F	Ø22.2		<flexible joints> <accessory>

[Maintenance access space]

Secure enough access space to allow for the maintenance, inspection, and replacement of the motor, fan, heat exchanger, drain pan and control box in one of the following ways.

Select an installation site for the indoor unit so that its maintenance access space will not be obstructed by beam or other objects.

Create access door 1 (450x450mm) for the maintenance from the unit side when the thermostat, LEV and control box is exchanged. (Fig.2.4)

(1) When a space of 500mm or more is available below the unit between the unit and the ceiling.  
Create access door 2 (600x600mm) for the maintenance from the bottom when the motor, fan, heat exchanger and drain pan is cleaned (exchanged). (Fig.2)

(2) When a space of less than 500mm is available below the unit between the unit and the ceiling.  
(At least 20mm of space should be left below the unit as shown in Fig.3)

Create access door 3 for the maintenance from the bottom when the motor, fan, heat exchanger and drain pan is cleaned (exchanged). (Fig.4)

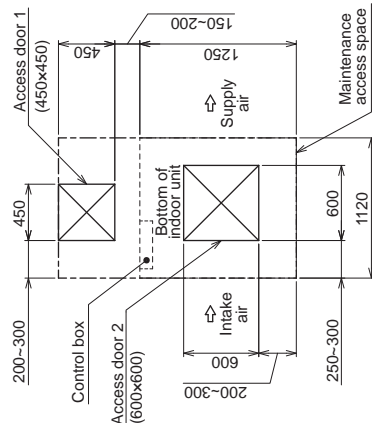

Fig.2 (Viewed from the direction of the arrow Z)

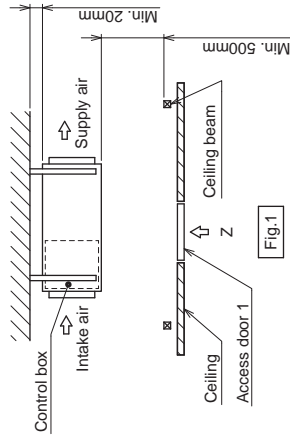

Fig.1

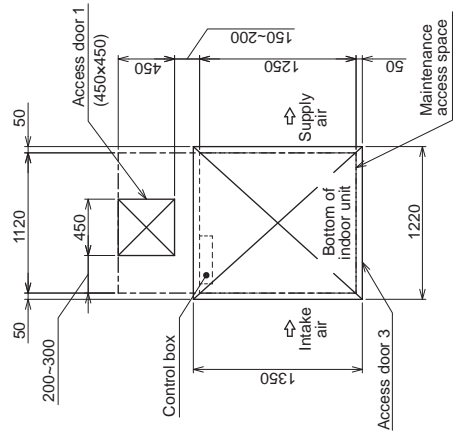

Fig.4 (Viewed from the direction of the arrow Y)

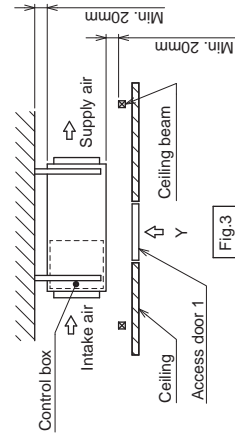
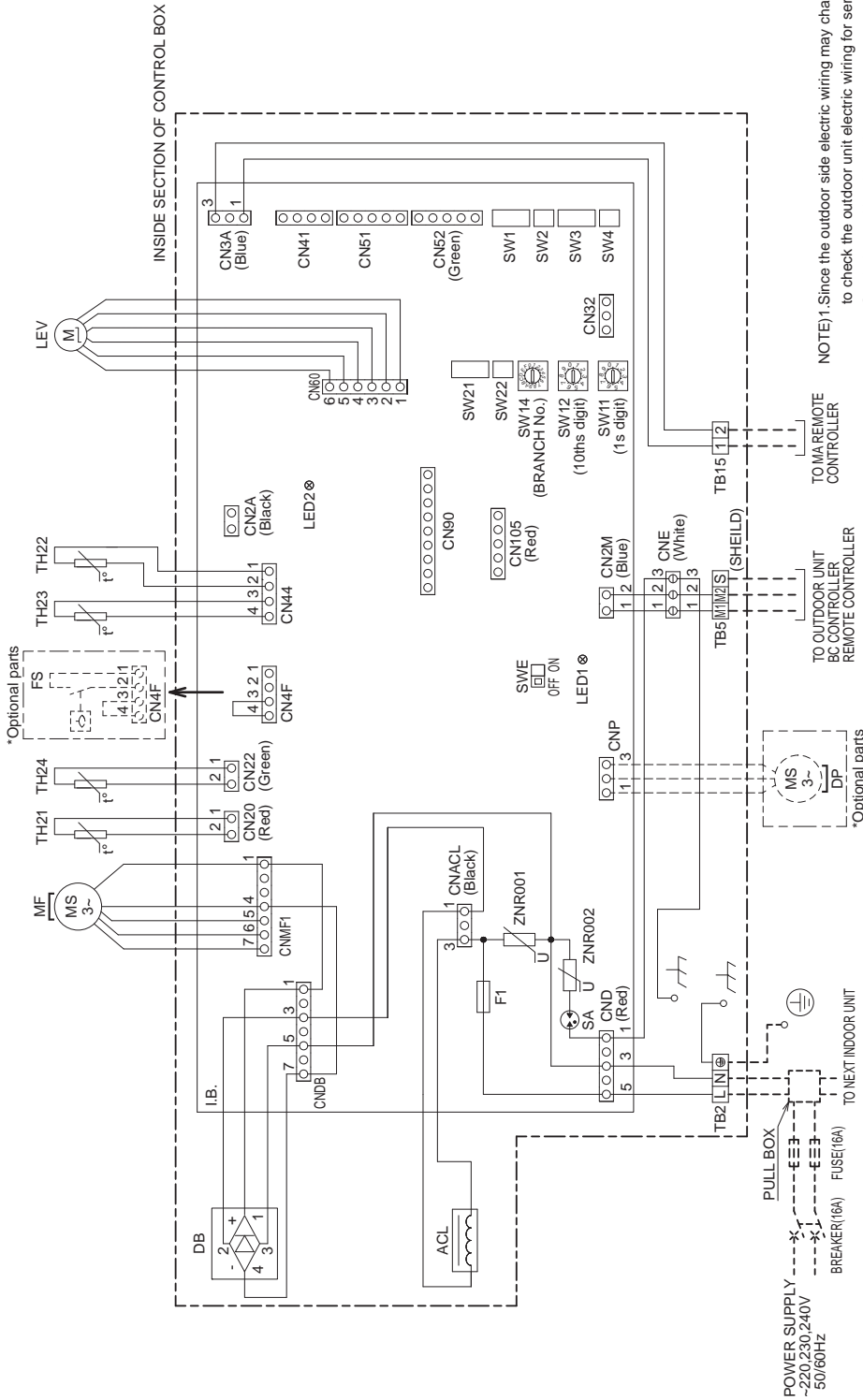

Fig.3

# [1] Wiring Diagram

## 1. PEFY-P125VMHS-E-F



### SYMBOL EXPLANATION

SYMBOL	NAME	SYMBOL	NAME	SYMBOL	NAME
ACL	AC reactor(Power factor improvement)	I.B.	Indoor controller board	SW3	Indoor controller board
DB	Diode Bridge	SA	Arrester	SW4	Switch (for mode selection)
DP	Drain Pump	F1	Fuse AC250V 6.3A	SW11	Switch (1s digit address set)
FS	Float switch	ZNR001,002	Varistor	SW12	Switch (10ths digit address set)
MF	Fan Motor	CN2A	Connector (0-10V Analog input)	SW14	Switch (BRANCH No.)
LEV	Electrical linear expansion valve	CN41	Connector (RHA terminal-A)	SW21	Switch (for static pressure selection)
TB2	Power source terminal block	CN51	Connector (Centrally control)	SW22	Switch (Wireless pair No.)
TB5	Transmission terminal block	CN52	Connector (Remote indication)	SWE	Connector (emergency operation)
TH21	Thermistor (blowing air temp. detection)	CN90	Connector (Wireless)	LED1	LED(Power supply)
TH22	Thermistor (piping temp.detection/liquid)	CN105	Connector (IT terminal)	LED2	LED(Remote controller supply)
TH23	Thermistor (piping temp.detection/gas)	SW1	Switch (for mode selection)		
TH24	Thermistor (outdoor air temp. detection)	SW2	Switch (for capacity code)		



2. PEFY-P200, 250VMHS-E-F

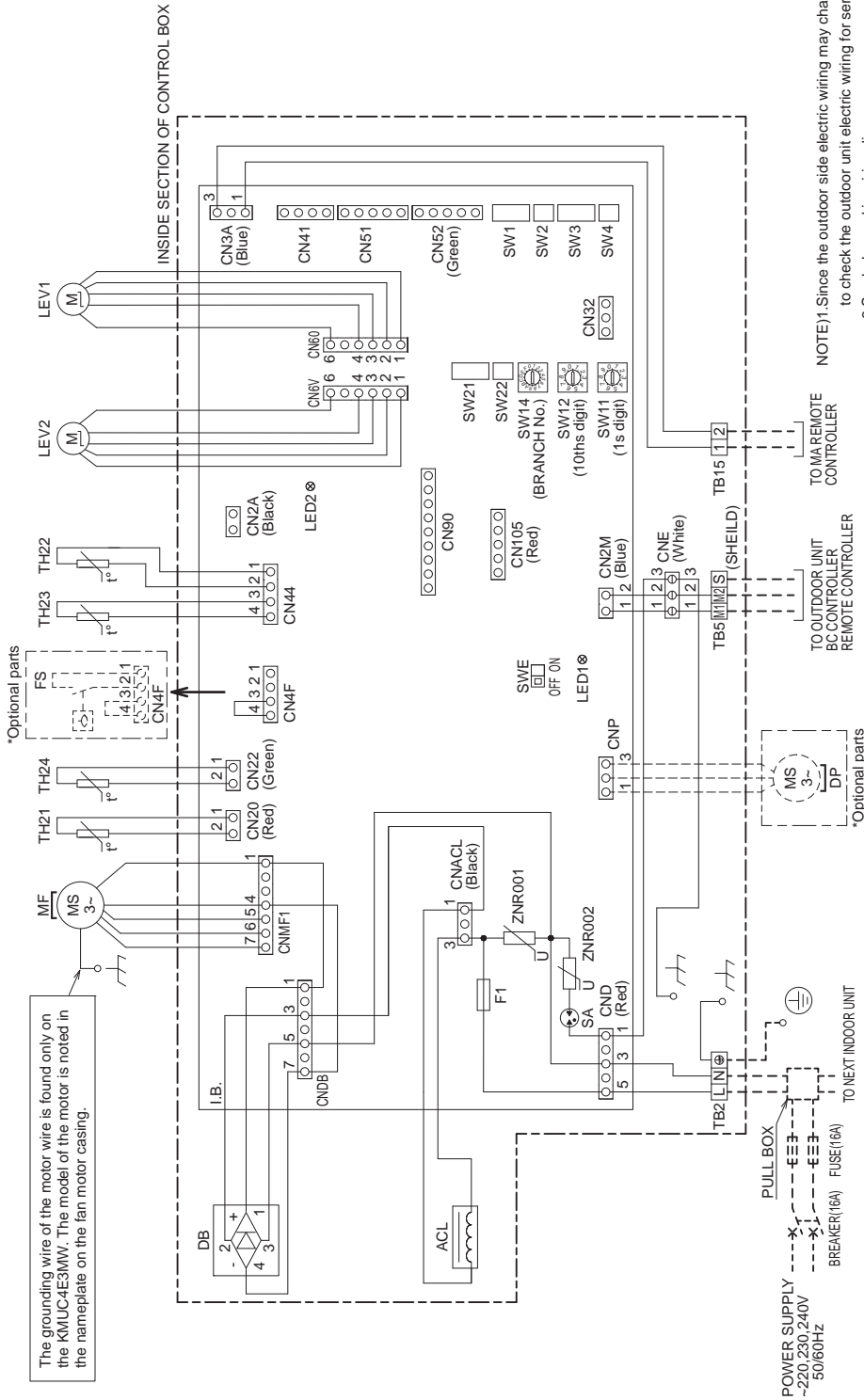

- NOTE)1. Since the outdoor side electric wiring may change be sure to check the outdoor unit electric wiring for servicing.
2. Symbols used in wiring diagram are
- ○ ○ ○ : Connector
  - : Terminal
  - (Heavy dotted line): Field wiring
  - (Thin dotted line): Optional parts
3. Have all electric work done by a licensed electrician according to the local regulations.
4. Earth leakage circuit breaker should be set up on the wiring of the power supply.
5. To perform a drainage test for the drain pump turn on the SWE on the control board while the indoor unit is being powered.
- \*Be sure to turn off the SWE after completing a drainage test or test run.

**SYMBOL EXPLANATION**

SYMBOL	NAME	SYMBOL	NAME	SYMBOL	NAME
ACL	AC reactor(Power factor improvement)	I.B.	Indoor controller board	SW3	Switch (for mode selection)
DB	Diode Bridge	F1	Fuse AC250V 6.3A	SW4	Switch (for model selection)
DP	Drain Pump	ZNR001,002	Varistor	SW11	Switch (1s digit address set)
FS	Float switch	CN2A	Connector (0-10V Analog input)	SW12	Switch (10ths digit address set)
LEV1,LEV2	Fan Motor	CN32	Connector (Remote switch)	SW14	Switch (BRANCH No.)
TB2	Electrical linear expansion valve	CN41	Connector (Remote switch)	SW21	Switch (for static pressure selection)
TB5	Power source terminal block	CN51	Connector (Centrally control)	SW22	Switch (Wireless pair No.)
TB15	Transmission terminal block	CN52	Connector (Centrally control)	SWE	Connector (emergency operation)
TH21	Thermistor (blowing air temp. detection)	CN90	Connector (Wireless)	LED1	LED(Power supply)
TH22	Thermistor (piping temp.detection/liquid)	CN105	Connector (IT terminal)	LED2	LED(Remote controller supply)
TH23	Thermistor (piping temp.detection/gas)	SW1	Switch (for mode selection)		
TH24	Thermistor (outdoor air temp. detection)	SW2	Switch (for capacity code)		

**[1] Refrigerant System Diagram**

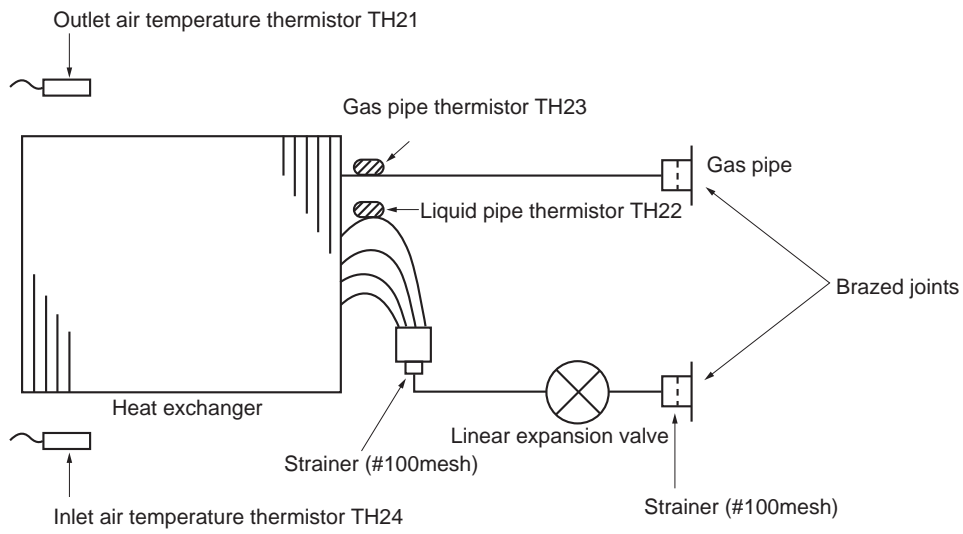

Capacity	PEFY-P125VMHS-E-F	PEFY-P200VMHS-E-F	PEFY-P250VMHS-E-F
Gas pipe	ø15.88 [5/8]	ø19.05 [3/4]	ø22.2 [7/8]
Liquid pipe	ø9.52 [3/8]	ø9.52 [3/8]	ø9.52 [3/8]

**[1] Troubleshooting**

**1. Check methods**

1. Component and check points

(1) Thermistor

- Blowing air temperature thermistor (TH21)
- Liquid pipe thermistor (TH22)
- Gas pipe thermistor (TH23)
- Outdoor air temperature thermistor (TH24)

Disconnect the connector and measure the resistance between terminals with a tester.  
(Ambient temperature 10°C - 30°C)

Normal	Abnormal
4.3kΩ - 9.6kΩ	Open or short

(Refer to the thermistor characteristic graph below.)

1) Thermistor characteristic graph

**Low-temperature thermistor**

- Room temperature thermistor (TH21)
- Liquid pipe thermistor (TH22)
- Gas pipe thermistor (TH23)
- Drain sensor (DS)

- Thermistor  $R_0 = 15\text{ k}\Omega \pm 3\%$
- Multiplier of B =  $3480\text{ k}\Omega \pm 2\%$

$$R_t = 15 \exp \left\{ 3480 \left( \frac{1}{273+t} - \frac{1}{273} \right) \right\}$$

- 0°C 15kΩ
- 10°C 9.6kΩ
- 20°C 6.3kΩ
- 25°C 5.2kΩ
- 30°C 4.3kΩ
- 40°C 3.0kΩ

(A) Temperature (°C)

(B) Resistance (kΩ)

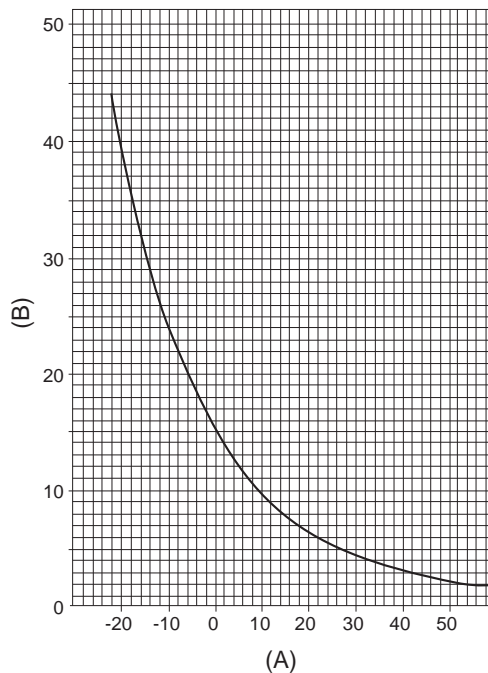

(2) Fan motor (CNMF)

Refer to the page on "DC fan motor (fan motor/indoor control board)."

(3) Linear expansion valve

Disconnect the connector, and measure the resistance between terminals with a tester.  
Refer to the next page for details.

	Normal				Abnormal
	1-6 White-Red	2-6 Yellow-Red	3-6 Orange-Red	4-6 Blue-Red	Open or short
	(150Ω) ± 10%				

- (A) Red
- (B) Blue
- (C) Orange
- (D) Yellow
- (E) White
- (F) White

1) Summary of linear expansion valve (LEV) operation

- The LEV is operated by a stepping motor, which operates by receiving a pulse signal from the indoor control board.
- The LEV position changes in response to the pulse signal.

**Indoor control board and LEV connection**

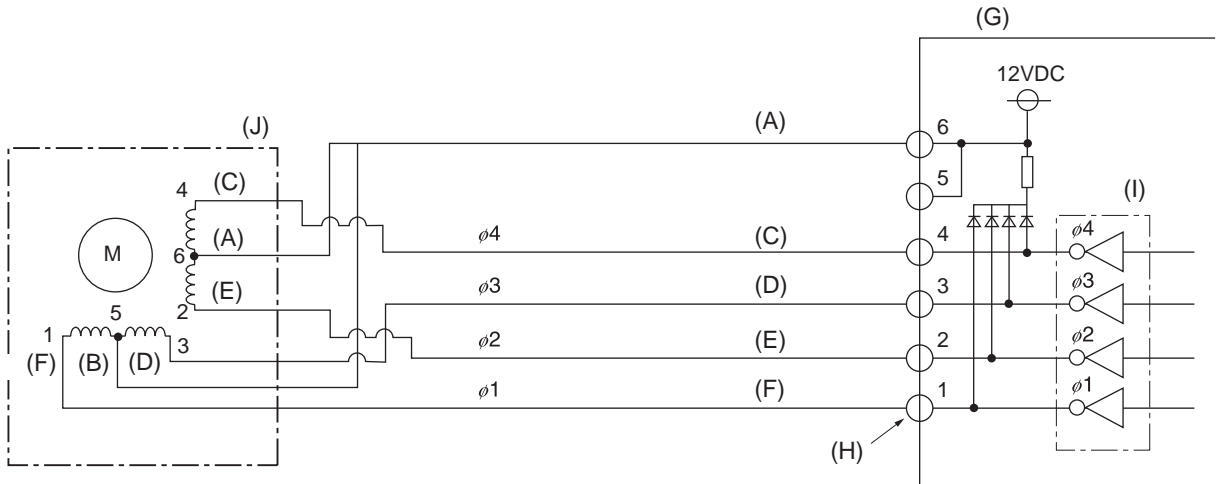

- |            |                            |
|------------|----------------------------|
| (A) Red    | (G) Control board          |
| (C) Blue   | (H) Connection (CN60)      |
| (D) Orange | (I) Drive circuit          |
| (E) Yellow | (J) Linear expansion valve |
| (F) White  |                            |

**Pulse signal output and valve operation**

Phase number	Output pulse			
	1	2	3	4
ø1	ON	OFF	OFF	ON
ø2	ON	ON	OFF	OFF
ø3	OFF	ON	ON	OFF
ø4	OFF	OFF	ON	ON

The output pulse changes in the following order:

When the valve closes 1 -> 2 -> 3 -> 4 -> 1

When the valve opens 4 -> 3 -> 2 -> 1 -> 4

- When the valve position remains the same, all output signals will be OFF.
- If any output signal is missing or if the signal remains ON, the motor vibrates and makes clicking noise.

2) LEV operation

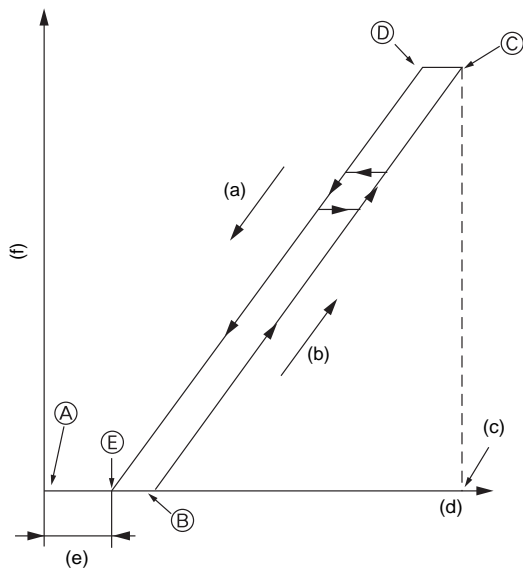

- (a) Close
- (b) Open
- (c) Fully open valve (2000 pulses)
- (d) No. of pulses
- (e) Extra tightening (41 pulses)
- (f) Valve opening degree

- When the power is turned on, a pulse signal of fully open pulse + 10% pulse is output (valve closure signal), to bring the valve to position A.
- When the valve is operating normally, it is free of vibration noise. If the valve locks or when it goes from point E to A in the figure, it makes louder noise than would be heard when there is an open phase.
- Check for abnormal sound/vibration by placing the metal tip of a screwdriver against the valve and the handle side against your ear.

3) Troubleshooting

Symptom	Checking Criteria	Remedy
Circuit failure on the microcomputer	Disconnect the connectors on the control board, and connect LEDs to test the circuit as shown below.    Pulse signals are output for 10 seconds when the main power is turned on. If there are LEDs that do not light up at all or remain lit after the pulses are turned off, there is a problem with the driving circuit.	Replace the indoor control board if driving circuit failure is detected.
Locked LEV	The motor will idle and make small clicking noise if it is run while the LEV is locked. If this clicking noise is heard both when the valve is fully closed and while it is being opened, it indicates a problem.	Replace the LEV.
Disconnected or shorted LEV motor coils	Measure the resistance between the coils with a tester (red-white, red-orange, Red-yellow, Red-blue). The normal range of resistance is $150\Omega \pm 10\%$	Replace the LEV.

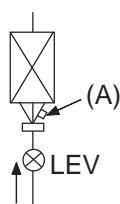
<p>Valve closure failure (leaky valve)</p>	<p>To check the LEV on the indoor unit, check the indoor unit liquid pipe temperature that appears on the operation monitor on the outdoor unit's multi control board while operating the indoor unit in question in the FAN mode and the other indoor units in the cooling mode.</p> <p>(A) Termistor (TH22)</p>  <p>Normally, the LEV is fully closed while the unit is in the FAN mode. If the valve is leaky, liquid pipe thermistor reading will be lower than normal. If it is significantly lower than the inlet temperature on the remote controller, valve closure failure is suspected. If the amount of leakage is insignificant, replacement of LEV is unnecessary unless it is causing a problem.</p>	<p>Replace the LEV if the amount of leakage is great.</p>
<p>Misconnections of connectors or contact failure</p>	<p>Perform a visual check for disconnected connectors. Perform a visual check of lead wire color.</p>	<p>Disconnect the connectors on the control board and perform a continuity test.</p>

(4) Drain pump

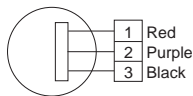

1. Check if the drain float switch works properly.
2. Check if the drain pump works and drains water properly in cooling operation.
3. If no water drains, confirm that the check code 2502 will not be displayed 10 minutes after the operation starts.

Note: The drain pump for this model is driven by the internal DC motor of controller board, so it is not possible to measure the resistance between the terminals.

Normal

Red-Black: Input 13V DC → The fan starts to rotate.

Purple-Black: Abnormal (check code 2502) if it outputs 0-13 V square wave (5 pulses/rotation), and the number of rotation is not normal.

(5) Drain float switch (CN4F)

Disconnect the connector, and measure the resistance between terminals with a tester.

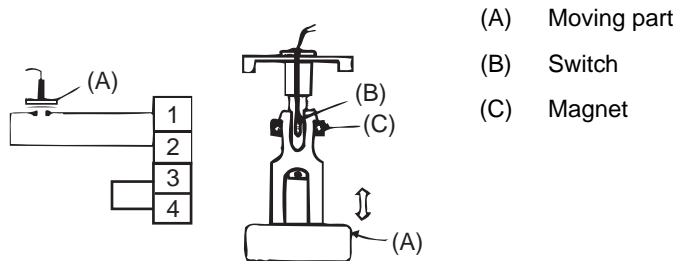

Position of the moving part	Normal	Abnormal
Up	Short	(any position but short)
Down	Open	(any position but open)

## 2. DC fan motor (fan motor/indoor control board)

### 1. CAUTION

- A high voltage is applied to the connector for connection to the fan motor (CNMF1).
- Do not unplug the connector CNMF1 with the unit energized to avoid damage to the indoor control board and fan motor.
- Electric shock hazard. Do not touch the motor when energized.

### 2. Troubleshooting

- Symptom: Indoor unit fan does not run.

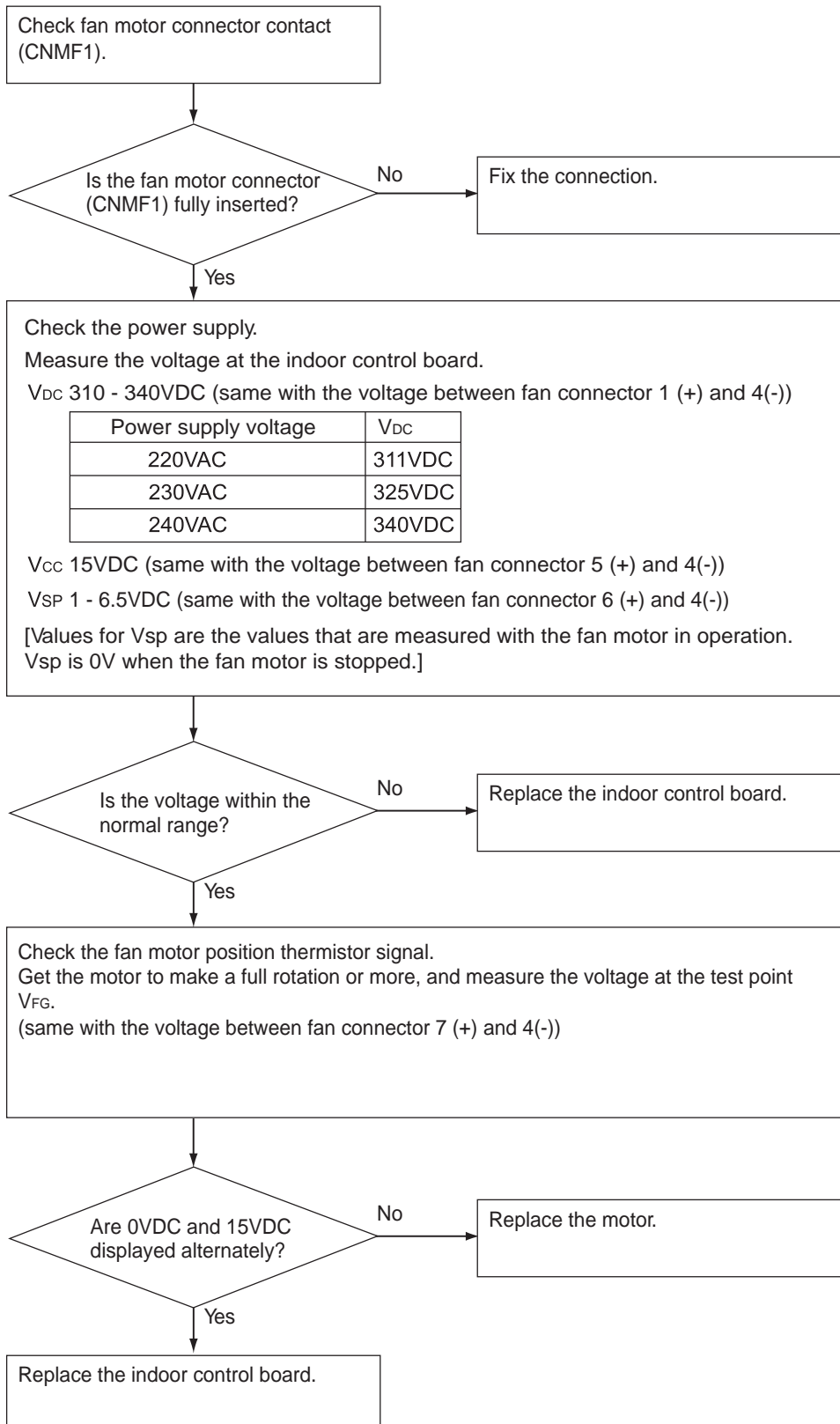

### 3. Setting of address switch

Make sure that power source is turning off.

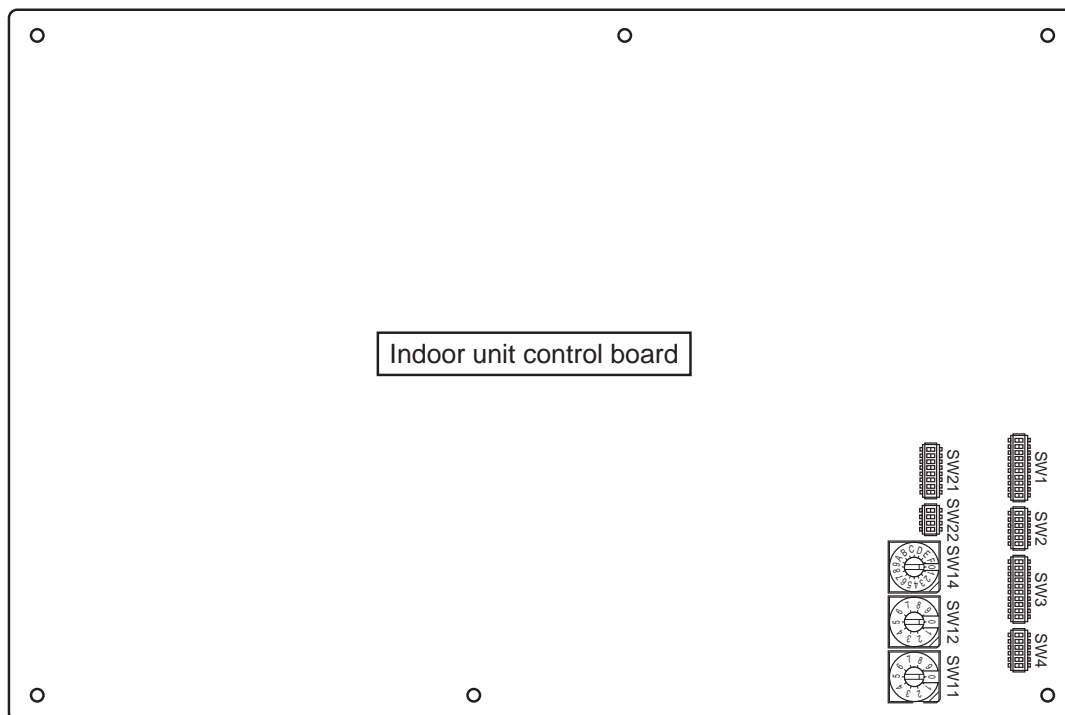

**1) In case using network remote controller, address is set by rotary switches. (SW11,SW12)**

\*It is not necessary setting address in case of using unit remote controller.

**Indoor unit do not run without address setting in field.**

**2) Indoor unit address setting rule is different by each field work.**

Refer to install manual of outdoor unit, operate the address setting.

**3) Setting the address is combination of SW11 (1st digit address setting) and SW12 (2nd digit address setting).**

Address " 3 " setting is composed SW11 " 3 " and SW12 " 0 ".

Address " 25 " setting is composed SW11 " 5 " and SW12 " 2 ".





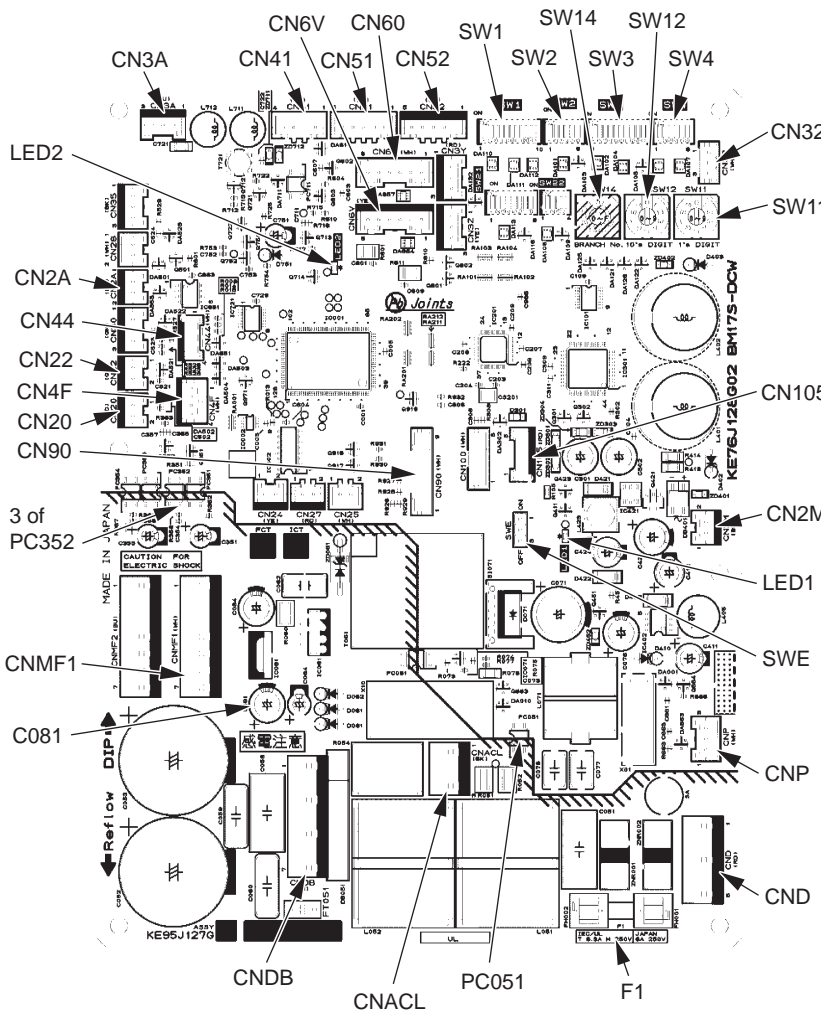





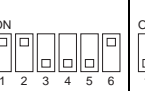
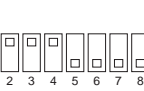

### 4. Voltage test points on the control board

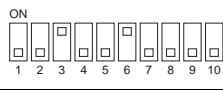
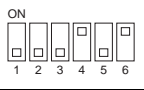
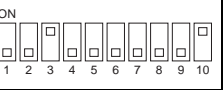
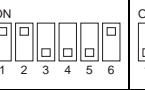
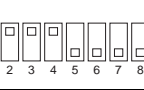

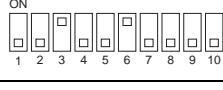
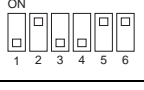
- F1 Fuse (AC 250V 6.3A)
  - CND Power supply voltage (220 - 240VAC)
  - CN2M For M-NET transmission cable connection (24 - 30VDC)
  - SWE Emergency operation
  - SW2 Capacity setting
  - SW4 Function setting
  - SW3 Function setting
  - CN32 Remote start/stop adapter
  - CN105 CN3A For MA remote controller cable connection (10 - 13 VDC (Between 1 and 3.))
  - CN52 Remote display
  - CN51 Centralized control
  - LED1 CN41 JAMA standard HA terminal A
  - CN44 Thermistor (liquid/gas temperature)
  - SWE CN4F Float thermistor
  - CN22 Thermistor (Inlet air temperature)
  - CN20 Thermistor (Outlet temperature)
  - CNMF1 Fan motor output  
 1 - 4: 294 - 340 VDC  
 5 - 4: 15 VDC  
 6 - 4: 0 - 6.5 VDC  
 7 - 4: Stop 0 or 15 VDC  
 Run 7.5 VDC  
 (0 - 15 pulse)
  - CNP Drain-up mechanism output (200VAC)
- (\*1)
- V<sub>FG</sub> Voltage on 3 of PC352 and the (-) side of C081  
 (Same with the voltage between 7 (+) and 4 (-) of CNMF)
  - V<sub>CC</sub> Voltage between the C25 pins  
 15 VDC  
 (Same with the voltage between 5 (+) and 4 (-) of CNMF)
  - V<sub>sp</sub> Voltage between the C53 pins  
 0VDC (with the fan stopped)  
 1 - 6.5VDC (with the fan in operation)  
 (Same with the voltage between 6 (+) and 4 (-) of CNMF)

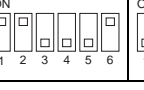
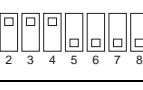
## 5. Setting of dip-switch (at delivery)

Models	SW1	SW2	SW3	SW4	SW21	SW22	SWE
PEFY-P125VMHS-E-F							
PEFY-P200VMHS-E-F							
PEFY-P250VMHS-E-F							

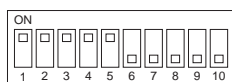

The figure at left shows that the switches 1 through 5 are set to ON and 6 through 10 are set to OFF.

## 6. Function setting

### (1) SW1

Switch position	Function	Switch setting	
		ON	OFF
1	Active Thermistor	-	Indoor unit
2	Filter clogging detection	Available	Unavailable
3	Filter life	2500 hr	100 hr
4	-	-	-
5	Remote display	Thermo-ON signal	Fan output
6	Drain pump	Unavailable	Available
7	-	-	-
8	-	-	-
9	Auto restart after power failure	Enabled	Disabled
10	Power start/stop	Enabled	Disabled

### (2) SW3

Switch position	Function	Switch setting	
		ON	OFF
1	Unit type	Cooling only	Heat pump
2	-	-	-
3	-	-	-
4	-	-	-
5	-	-	-
6	-	-	-
7	-	-	-
8	-	-	-
9	-	-	-
10	Thermo-OFF temperature for cooling	17°C	14°C

## 7. Selecting the airflow rate mode and external static pressure

This indoor unit supports two types of airflow rate modes and four external static pressure settings. The fan speed and the corresponding airflow rate for each mode vary with models as shown in the table below.

Model	Fan speed	Airflow rate [m <sup>3</sup> /min]	
		Normal-airflow rate mode	High-airflow rate mode
PEFY-P125VMHS-E-F	High	18	20
	Medium	15.5	18
	Low	14	15.5
PEFY-P200VMHS-E-F	High	28	32
	Medium	25	28
	Low	22.5	25
PEFY-P250VMHS-E-F	High	35	40
	Medium	31	35
	Low	28	31

Note:

- When the airflow rate mode and the static pressure setting were set from the remote controller, the actual setting and the switch setting on the control board may not match because the latest setting from the remote controller overrides the previous setting. To check the latest airflow rate mode and static pressure setting, check them on the remote controller, not on the switch.

### To set the airflow rate mode and the static pressure setting with the switches on the control board

Airflow rate mode	External static pressure	SW21-1	SW21-2	SW21-5
Normal-airflow rate mode	100 Pa	OFF	OFF	OFF
	150 Pa	ON	OFF	OFF
	200 Pa	OFF	ON	OFF
	250 Pa	ON	ON	OFF
High-airflow rate mode	100 Pa	OFF	OFF	ON
	150 Pa	ON	OFF	ON
	200 Pa	OFF	ON	ON
	250 Pa	ON	ON	ON

Set the switches on the control board (SW21-1, SW21-2, and SW21-5) as shown in the table at left.

### To set the airflow rate mode and the static pressure setting from the function selection screen on the remote controller (Some remote controllers do not support the function selection function. Refer to the Instruction Book of a given remote controller.)

Follow the instructions below and the instructions detailed in the remote controller manual for how to set the switches.

1. Set the function setting No. 32 (Switch setting/Function selection) to "2".
2. Set the function setting No. 115 to appropriate values, according to the airflow rate mode and the static pressure setting.

Selection	Function setting No.	Initial Setting	Current setting
	No. 32		
Switch setting	1	○	
Function selection	2		

Airflow mode	External static pressure setting	Function setting No.	Initial setting	Current setting
		No. 115		
Normal-airflow rate mode	100 Pa	1		
	150 Pa	2		
	200 Pa	3	○	
	250 Pa	4		
High-airflow rate mode	100 Pa	5		
	150 Pa	6		
	200 Pa	7		
	250 Pa	8		

**[Important]**  
Be sure to write down the settings for all functions in the “Current setting” row if any of the initial settings has been changed.

### 8. Enabling the function to prevent cold draft (during heating operation)

This indoor unit features a function that automatically changes the fan speed to Very Low when the outside temperature reaches at or below the preset temperature to reduce the undesired effect of cold outside air to the supply air. This function can be enabled or disabled and the trigger threshold temperature can also be selected by setting the function No. 117 to the desired setting. Refer to the table below for details.

Function setting No.	Setting	Initial setting	Current setting
No. 117			
1	Disabled		
2	Triggered at outside temperature of -5°C or below		
3	Triggered at outside temperature of -6°C or below		
4	Triggered at outside temperature of -7°C or below		
5	Triggered at outside temperature of -8°C or below		
6	Triggered at outside temperature of -9°C or below		
7	Triggered at outside temperature of -10°C or below	○	
15	Initialize the setting		

**[Important]**  
Be sure to write down the settings for all functions in the “Current setting” row if any of the initial settings has been changed.

### 9. Setting addresses

(Be sure to operate with the main power turned OFF.)

• There are two types of rotary switch setting available: setting addresses 1 to 9 and over 10, and setting branch numbers.

#### 1) How to set addresses

Example: If Address is “3”, remain SW12 (for over 10) at “0”, and match SW11 (for 1 to 9) with “3”.

Factory setting

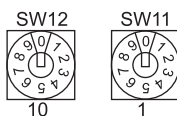

#### 2) How to set branch numbers SW14 (Series R2 only)

The branch number assigned to each indoor unit is the port number of the BC controller to which the indoor unit is connected.

Leave it to “0” on the non-R2 series of units.

Factory setting



- The rotary switches are all set to “0” when shipped from the factory. These switches can be used to set unit addresses and branch numbers at will.
- The determination of indoor unit addresses varies with the system at site. Set them referring to the Data Book.

### 10. Function the LED of the indoor unit service board

Symbol	Silk display	LED operation under normal state
LED1	Main power source	At applying main power source (indoor unit 200V) → Lighting
LED2	Transmission power source	At receiving M-NET transmission power source → Lighting

**[1] Disassembly Procedure (PEFY-P125VMHS-E-F)**

**1. Control box**

Be careful on removing heavy parts.

1. Removing the control box cover

(1) Remove the fixing screws (two) of the control box (A), and remove the cover. (Fig.1)

\*At this stage, the following servicing is possible. (Fig.2)

1) Operation and check of the switches (listed below) which are on the control board.

- Dip switch SW1 ..... Function change
- Dip switch SW2 ..... Capacity code setting
- Dip switch SW3 ..... Function change
- Dip switch SW4 ..... Model code setting
- Dip switch SW21 ..... Static pressure setting
- Dip switch SW22 ..... Function setting
- Rotary switches SW11, 12 .... Address setting
- Rotary switch SW14 ..... Branch port setting

2) Connection check of the lead wires (listed below) which are connected to the controller board.

- Power supply lead wire.
- Network remote controller transmission lead wire.
- Fan motor lead wire.
- LEV lead wire
- Intake air sensor lead wire
- Liquid piping sensor lead wire
- Gas piping sensor lead wire
- (•Drain pump lead wire)
- (•Drain sensor lead wire)

3) Control board exchange

4) Condenser exchange

5) Fuse (Fuse holder) exchange

6) Relay exchange

7) Intake air sensor exchange

8) Power supply terminal bed exchange

9) Transmission terminal bed exchange x 2

( ): Optional parts

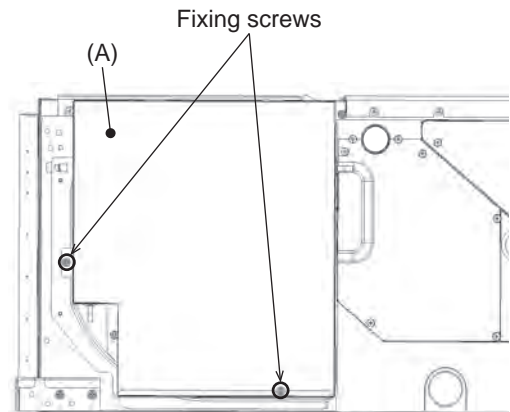

Fig.1

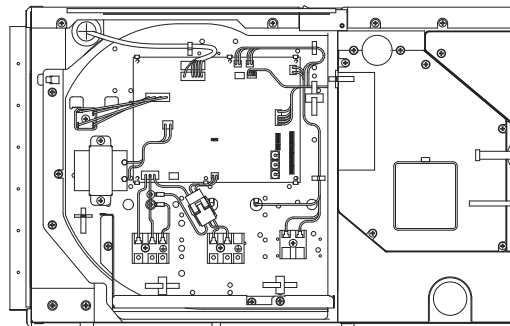

Fig.2

## 2. Fan and fan motor

**Be careful on removing heavy parts.**

**Electric shock hazard. Before performing any work, shut off the power supply.**

1. Remove the control box cover according to the procedure in section [1]-1. Control box.
2. Removing the fan motor cable
  - (1) Disconnect the connector (CNMF1) from the control board.
  - (2) Remove the cable through the rubber bush.
3. Removing the bottom plate
  - (1) Remove the fifteen fixing screws on the bottom plate to remove it.

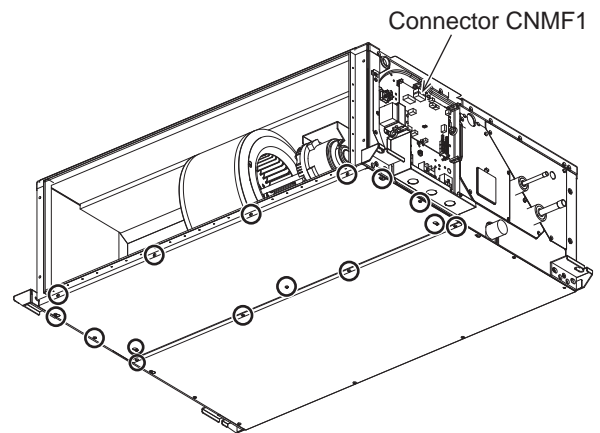

Fig.1

4. Removing the fan case
  - (1) Remove the four fixing screws on the fan case to remove it.

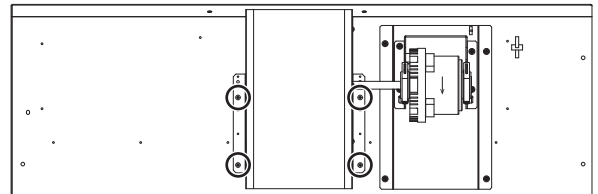

Fig.2

5. Removing the fan and fan motor
  - (1) Remove the two fixing screws and attachment on the fan motor.
  - (2) Pull out the fan motor in the direction of the arrow.

Exercise caution when removing heavy parts.

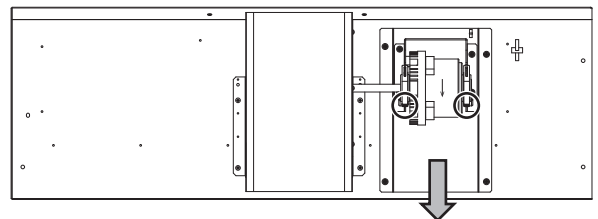

Fig.3

6. Precautions for reinstalling the removed motor in its original position
  - (1) Fix the motor in place so that the heat radiating fins on the motor and the stopper of the motor leg are positioned as shown in Fig. 4.

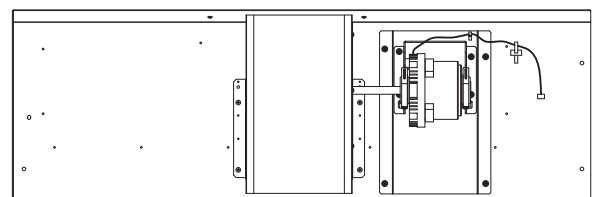
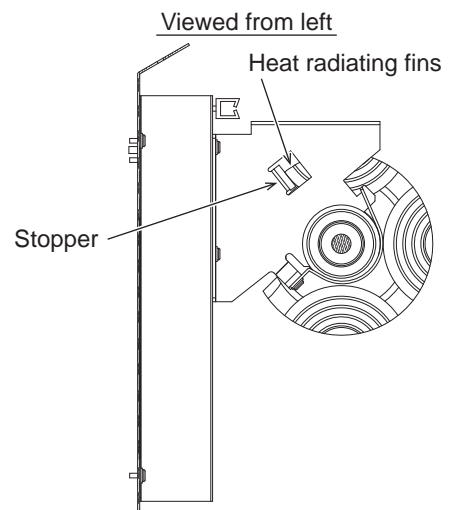

Fig.4



### 3. LEV, thermistor (Liquid/Gas piping temperature detection)

Be careful on removing heavy parts.

1. Removing the LEV.

- (1) Remove the control box cover with procedure [1]-1.
- (2) Remove the fixing screws (five) of the heat exchanger cover (A), and remove the cover (A). (Fig.1)
- (3) Remove the LEV driving motor. (Fig.2)

2. Removing the liquid pipe and gas pipe thermistor.

- (1) Remove the thermistors from the thermistor holders which are installed on the piping. (Fig.3)

3. Removing the outlet air temperature thermistor.

- (1) Remove control box cover with procedure [1]-1.
- (2) Remove the fixing screws (five) of the heat exchanger cover (A), and remove the cover (A). (Fig.1)
- (3) Remove the fixing screws (four) of maintenance cover (B), and remove the cover (B). (Fig.1)
- (4) Remove the cable bush from the panel, and pull the outlet air temperature thermistor through the hole. (Fig.4)

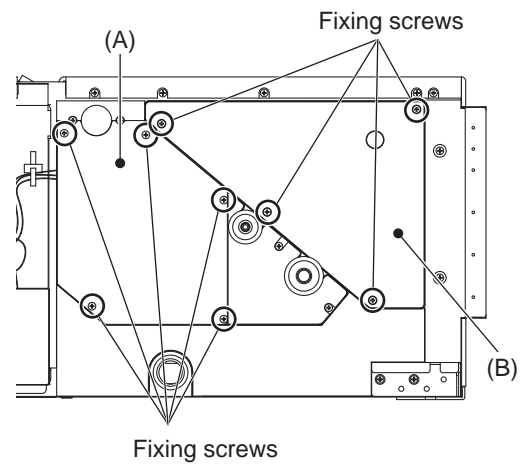

Fig.1

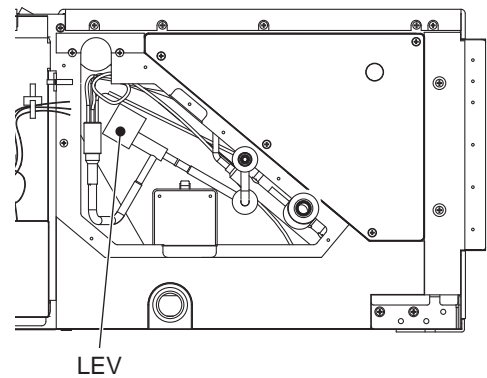

Fig.2

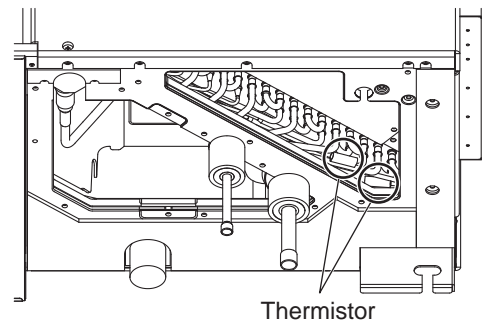

Fig.3

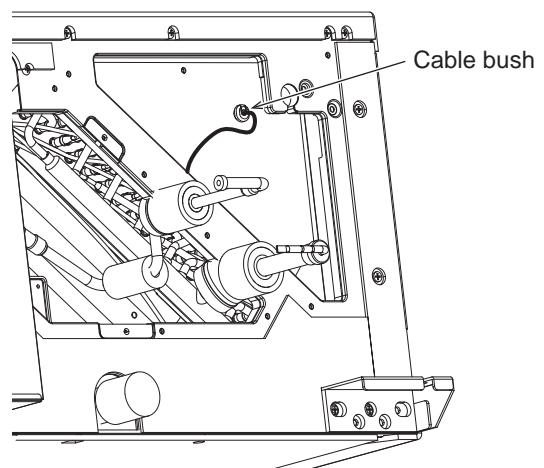

Fig.4

## 4. Heat exchanger

Be careful on removing heavy parts.

1. Removing the heat exchanger.
  - (1) Remove the heat exchanger cover with procedure [1]-3-1.
  - (2) Remove the bottom plate which is air outlet side. (fixing screws: twelve) (Fig.1)
  - (3) Remove the drainpan. (Fig.2)
  - (4) Remove the cover (A), (B). (fixing screws: two x 2) (Fig.3)

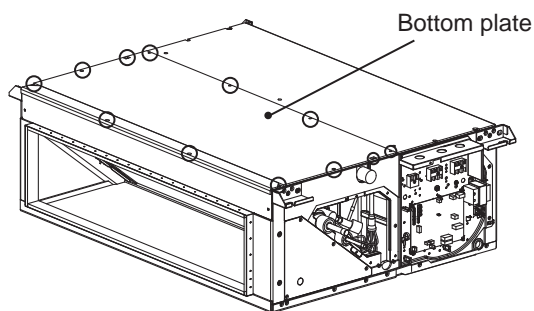

Fig.1

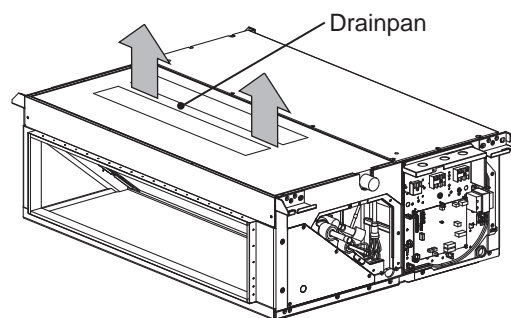

Fig.2

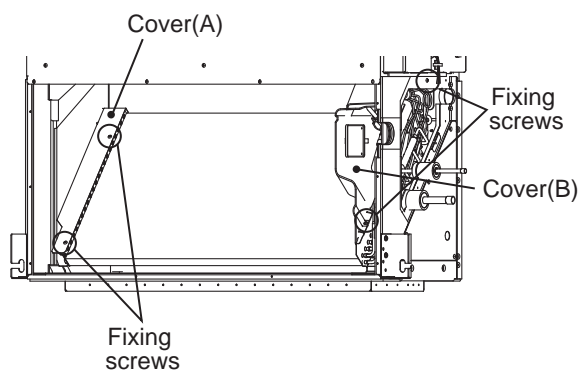

Fig.3



(5) Remove the maintenance cover. (fixing screws: four)  
(Fig.4)

(6) Remove the heat exchanger. (fixing screws: two)  
(Fig.5,6)

\*Removed heat exchanger is as shown in Fig.7

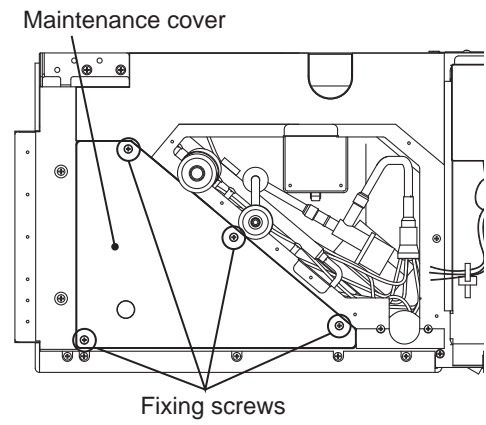

Fig.4

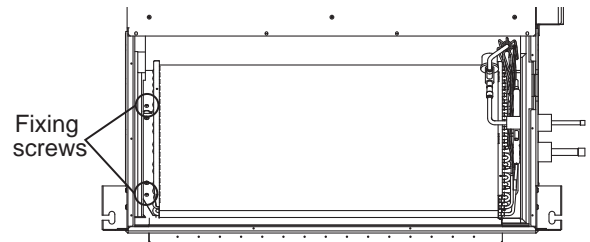

Fig.5

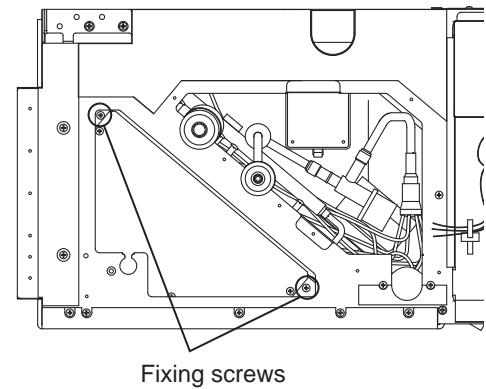

Fig.6

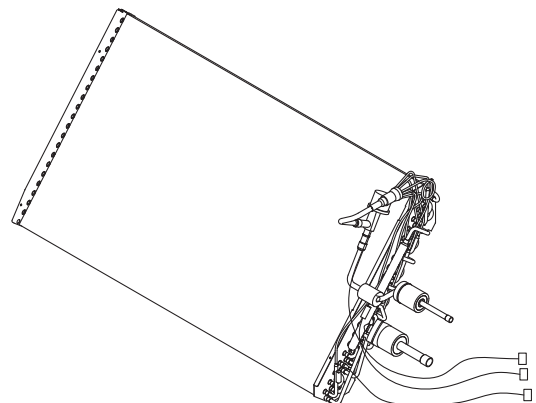
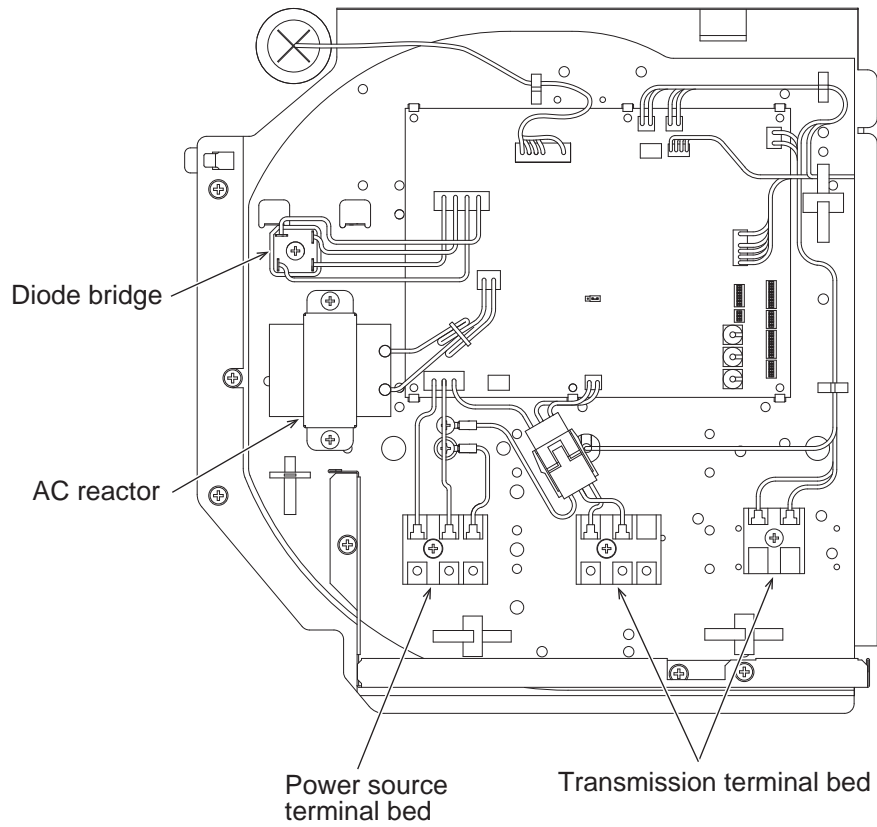

Fig.7

## 5. Control box inside layout



## 6. Sensor position

PEFY-P125VMHS-E-F

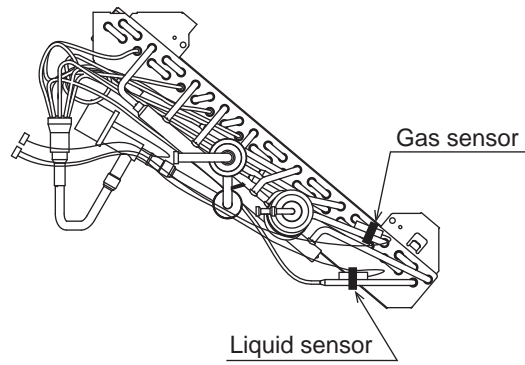

**[2] Disassembly Procedure (PEFY-P200, 250VMHS-E-F)**

**1. Control box**

**Be careful on removing heavy parts.**

1. Removing the control box cover

- (1) Remove the fixing screws (two) of the control box (A), and remove the cover. (Fig.1)

\*At this stage, the following servicing is possible. (Fig.2)

- 1) Operation and check of the switches (listed below) which are on the control board.

- Dip switch SW1 ..... Function change
- Dip switch SW2 ..... Capacity code setting
- Dip switch SW3 ..... Function change
- Dip switch SW4 ..... Model code setting
- Dip switch SW21 ..... Static pressure setting
- Dip switch SW22 ..... Function setting
- Rotary switches SW11, 12 ..... Address setting
- Rotary switch SW14 ..... Branch port setting

- 2) Connection check of the lead wires (listed below) which are connected to the controller board.

- Power supply lead wire.
- Network remote controller transmission lead wire.
- Fan motor lead wire.
- LEV lead wire
- Intake air sensor lead wire
- Liquid piping sensor lead wire
- Gas piping sensor lead wire
- (•Drain pump lead wire)
- (•Drain sensor lead wire)

- 3) Control board exchange
- 4) Intake air sensor exchange
- 5) Power supply terminal bed exchange
- 6) Transmission terminal bed exchange x 2
- 7) Ferrite core exchange

A ferrite core is required only when the model of fan motor is KMUC4E3MW. The model of the motor is noted in the nameplate on the fan motor casing.

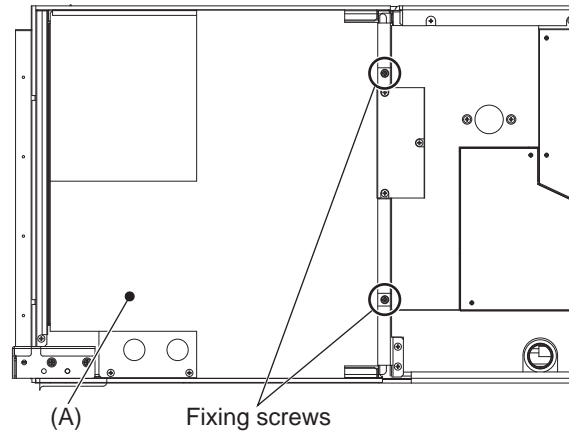

Fig.1

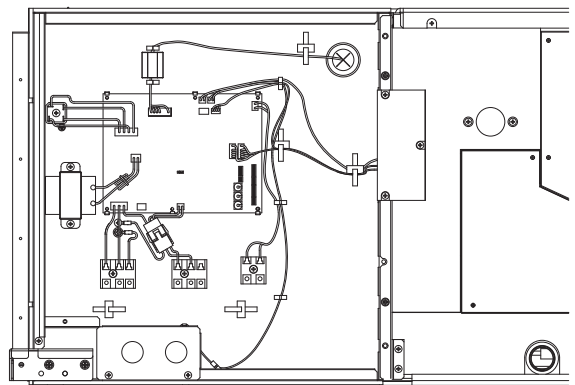

Fig.2

## 2. Fan and fan motor

Be careful on removing heavy parts.

Electric shock hazard. Before performing any work, shut off the power supply.

1. Remove the control box cover according to the procedure in section [2]-1. Control box.

### 2. Removing the fan motor cable

- (1) Disconnect the connector (CNMF1) from the control board and remove the ferrite core from the cable (Fig.2). A ferrite core is attached to the wire only when the model of fan motor is KMUC4E3MW. The model of the motor is noted in the nameplate on the fan motor casing.

- (2) Remove the cable through the rubber bush.

### 3. Removing the bottom plate

- (1) Remove the thirteen fixing screws on the bottom plate to remove it.

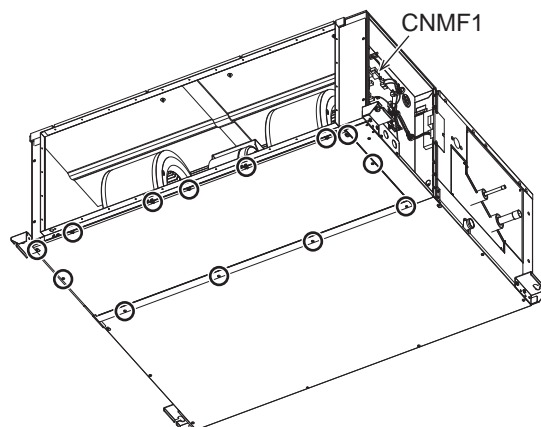

Fig.1

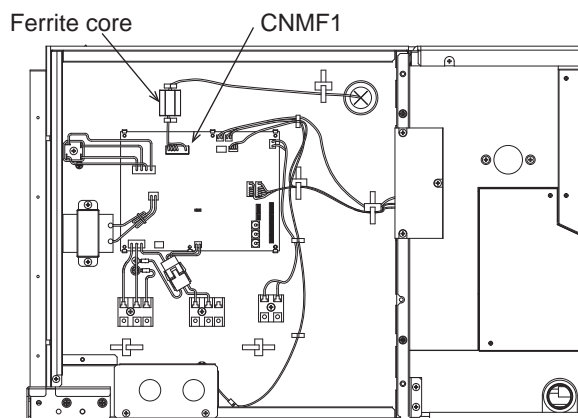

Fig.2

### 4. Removing the fan case

- (1) Remove the eight fixing screws on the fan case to remove it (Fig.3).

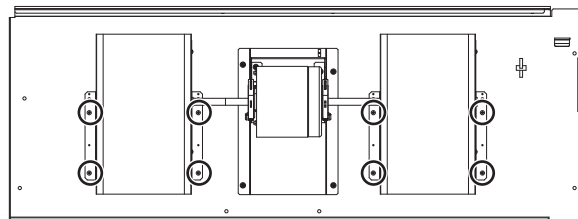

Fig.3

5. Removing the fan and fan motor

- (1) Remove the earth lead of the motor from the motor base. (Fig. 4)

The grounding wire of the motor wire is found only on the KMUC4E3MW. The model of the motor is noted in the nameplate on the fan motor casing.

- (2) Remove the two fixing screws and attachment on the fan motor (Fig. 5).
- (3) Pull out the fan motor in the direction of the arrow (Fig.5).

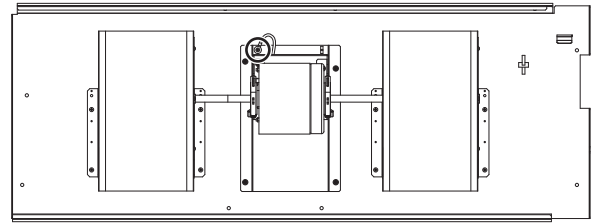

Fig.4

Exercise caution when removing heavy parts.

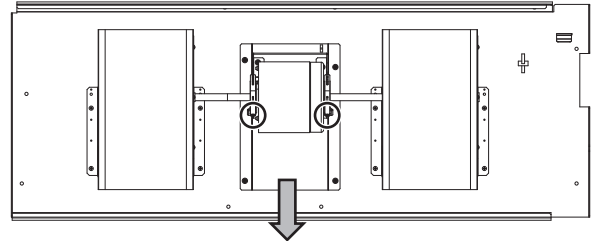

Fig.5

6. Precautions for reinstalling the removed motor in its original position

- (1) Fix the motor in place so that the heat radiating fins on the motor and the stopper of the motor leg are positioned as shown in Fig. 6.

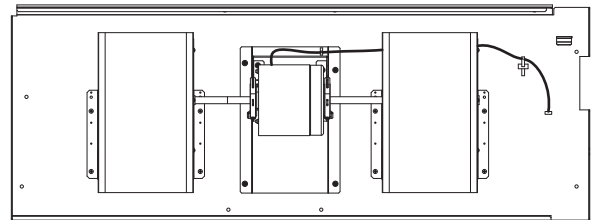
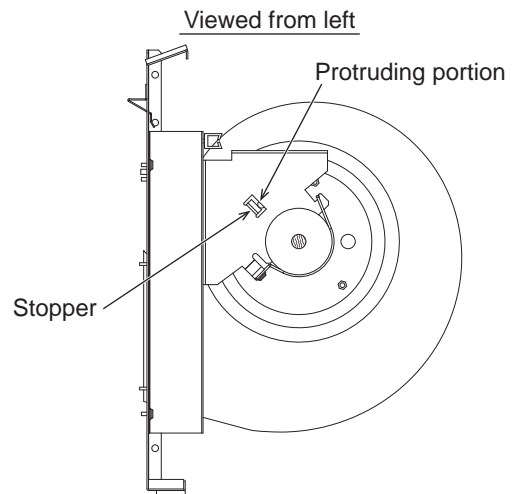

Fig.6



### 3. LEV, thermistor (Liquid/Gas piping temperature detection)

Be careful on removing heavy parts.

1. Removing the LEV.
  - (1) Remove the control box cover with procedure [2]-1.
  - (2) Remove the fixing screws (three) of the heat exchanger cover (A), and remove the cover (A). (Fig.1)
  - (3) Remove the LEV driving motor. (Fig.2)
  
2. Removing the liquid pipe and gas pipe thermistor.
  - (1) Remove the thermistors from the thermistor holders which are installed on the piping. (Fig.3)
  
3. Removing the outlet air temperature thermistor.
  - (1) Remove control box cover with procedure [2]-1.
  - (2) Remove the fixing screws (three) of the heat exchanger cover (A), and remove the cover (A). (Fig.1)
  - (3) Remove the fixing screws (four) of maintenance cover (B), and remove the cover (B). (Fig.1)
  - (4) Remove the cable bush from the panel, and pull the outlet air temperature thermistor through the hole. (Fig.4)

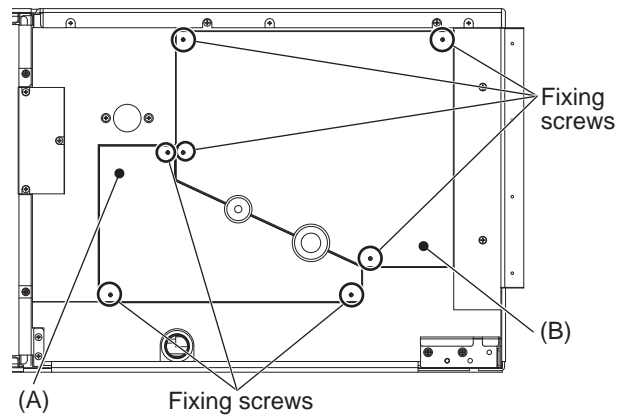

Fig.1

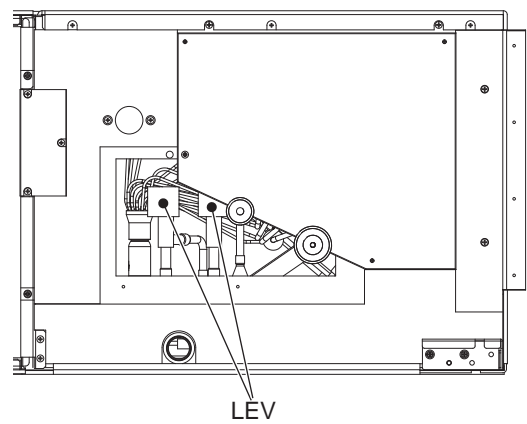

Fig.2

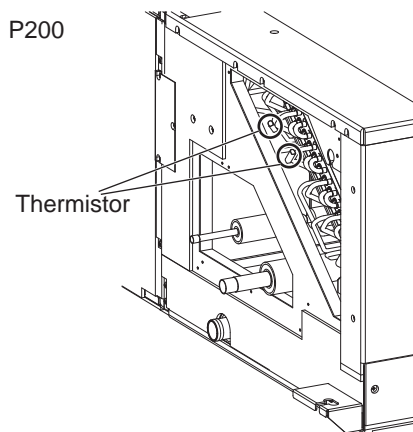

Fig.3

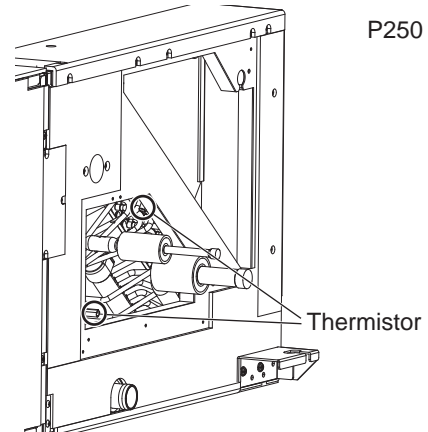

Fig.4

## 4. Heat exchanger

Be careful on removing heavy parts.

1. Removing the heat exchanger.
  - (1) Remove the heat exchanger cover with procedure [2]-3-1.
  - (2) Remove the bottom plate which is air outlet side. (fixing screws: twelve) (Fig.1)
  - (3) Remove the drainpan. (Fig.2)
  - (4) Remove the two fixing screws. (Fig.3)

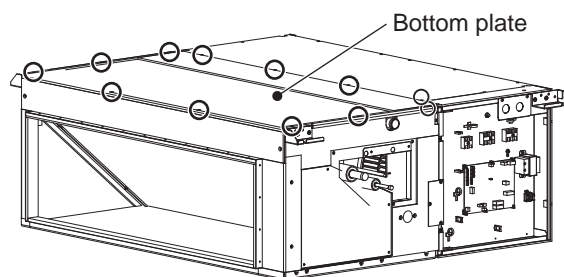

Fig.1

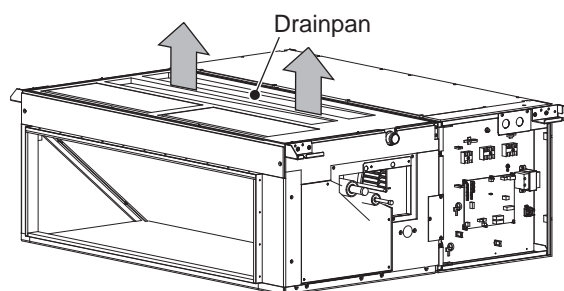

Fig.2

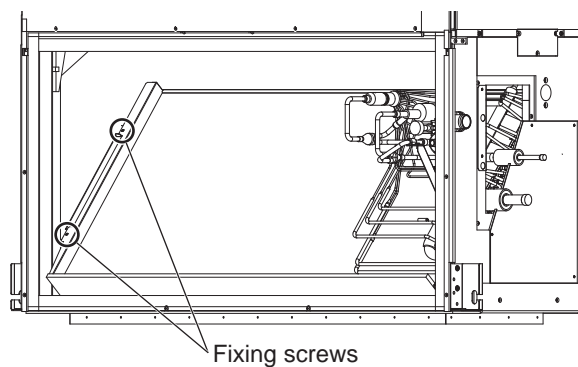

Fig.3



- (5) Remove the maintenance cover. (fixing screws: four) (Fig.4)
- (6) Remove the heat exchanger. (fixing screws: two) (Fig.5)

\*Removed heat exchanger is as shown in Fig.6

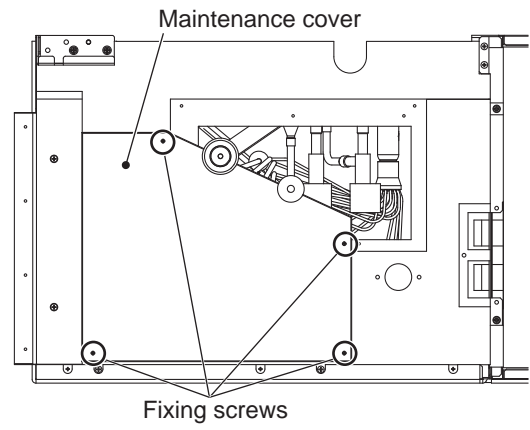

Fig.4

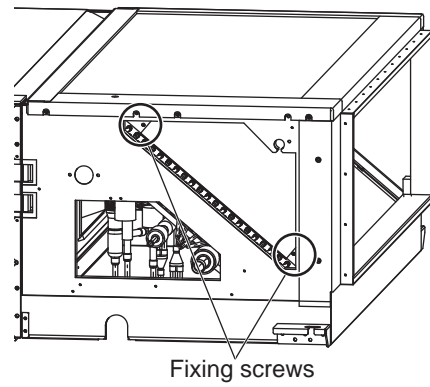

Fig.5

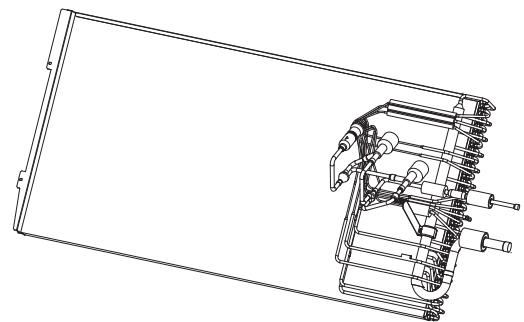
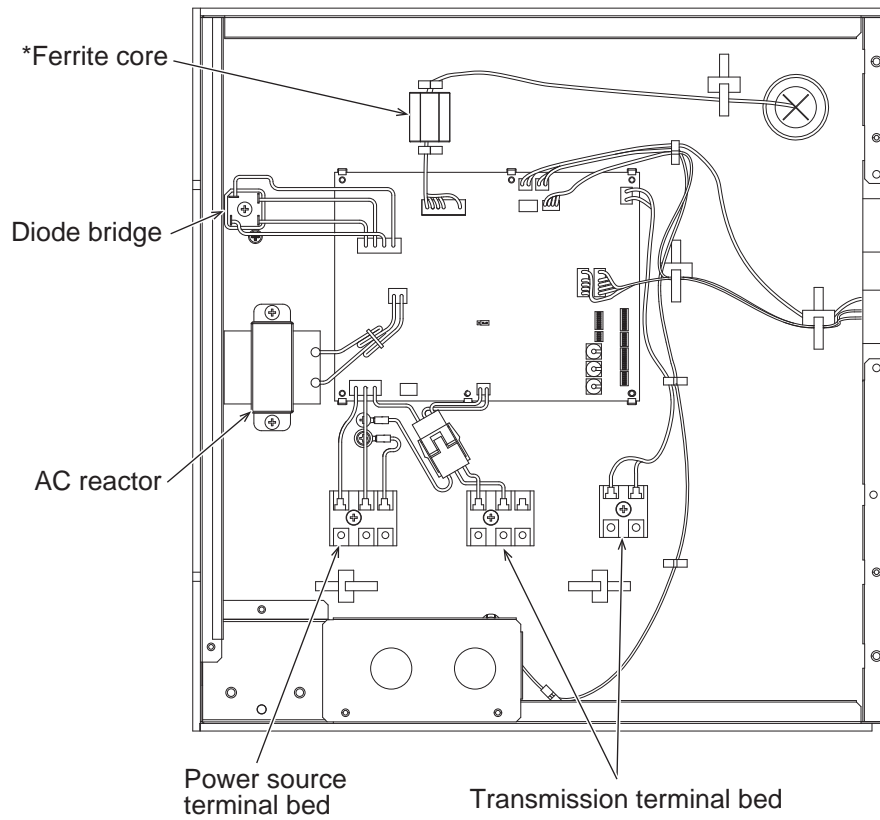

Fig.6

## 5. Control box inside layout



\*A ferrite core is required only when the model of fan motor is KMUC4E3MW. The model of the motor is noted in the nameplate on the fan motor casing.

## 6. Sensor position

PEFY-P200VMHS-E-F

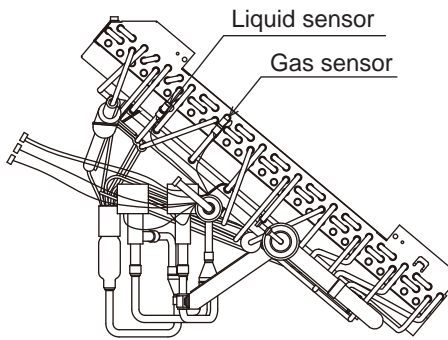

PEFY-P250VMHS-E-F

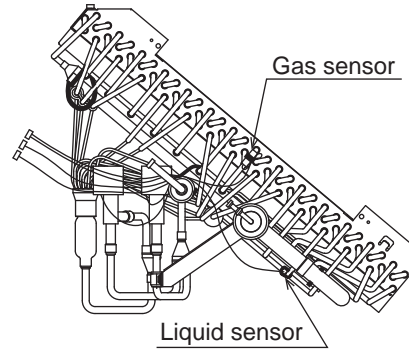

# **mitsubishi electric corporation**

[www.MitsubishiElectric.com](http://www.MitsubishiElectric.com)

---