

Compact Indoor Units

For all models unit height are unified to 250mm. Compared to the previous PEFY-P VMM model, the height size is reduced by 75mm (models 100-140), allowing installation in tight spaces, such as ceiling cavities or drop-ceilings.



**Reduction of
75mm**
(models 100-140)
compared to PEFY-P VMM

Ceiling concealed type

Ceiling concealed PEFY-P VMA(L)-E New



PEFY-P VMA(L)	20	25	32	40	50	63	71	80	100	125	140
Height mm	250										
Width mm	700		900			1,100			1,400		1,600
Depth mm	732										

External static pressure

Five-stage external static pressure settings provide flexibility for duct extension, branching and air outlet configuration and are adjustable to meet different application conditions. Setting ranges to a maximum of 150Pa.

External static pressure setting

Series	20	25	32	40	50	63	71	80	100	125	140	
PEFY-P VMM	30/50/100Pa								50/130Pa			
New PEFY-P VMA(L)	35/50/70/100/150Pa											

PEFY-P20/25/32/40/50/63/71/80/100/125/140VMA(L)

The PEFY-P VMA(L) series are ducted indoor units concealed within the ceiling space to allow unobtrusive air conditioning. With a thin body, they are the perfect answer for the air conditioning needs of buildings with minimum ceiling installation space. The unit precisely controls the indoor temperature while operating with optimum energy usage offering a higher energy-saving efficiency and reduction in electricity consumption.

Drain Pump Option

The line-up consists of two types, models with or without a built-in drain pump allowing more freedom in piping layout design.

- PEFY-P VMA-E
Drain pump built-in
 - PEFY-P VMAL-E
No Drain pump
- *Units with a "L" at the end of the model name are not equipped with a drain pump.

Air volume control

For PEFY-P63-140VMA(L) models, indoor unit air volume can be controlled with an opening-closing of a damper. Either by an analog input or a contact input. For further information, contact your nearest distributor.

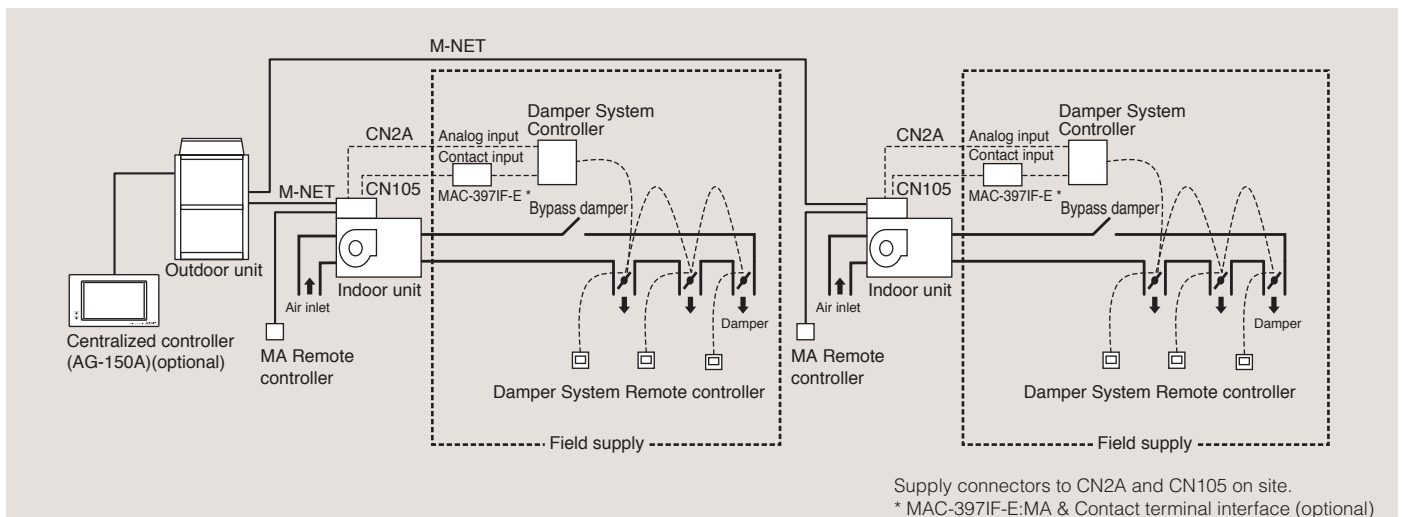

Specification

Model name		PEFY-P20VMA(L)-E	PEFY-P25VMA(L)-E	PEFY-P32VMA(L)-E	PEFY-P40VMA(L)-E	PEFY-P50VMA(L)-E	PEFY-P63VMA(L)-E	PEFY-P71VMA(L)-E	PEFY-P80VMA(L)-E	PEFY-P100VMA(L)-E	PEFY-P125VMA(L)-E	PEFY-P140VMA(L)-E	
Power source		1-phase 220-230-240V 50Hz											
Cooling capacity	*1 kW	2.2	2.8	3.6	4.5	5.6	7.1	8.0	9.0	11.2	14.0	16.0	
	*1 BTU/h	7,500	9,600	12,300	15,400	19,100	24,200	27,300	30,700	38,200	47,800	54,600	
Heating capacity	*3 kW	2.5	3.2	4.0	5.0	6.3	8.0	9.0	10.0	12.5	16.0	18.0	
	*3 BTU/h	8,500	10,900	13,600	17,100	21,500	27,300	30,700	34,100	42,700	54,600	61,400	
Power consumption	*2 Cooling kW	0.06[0.04]		0.07[0.05]	0.09[0.07]	0.11[0.09]	0.12[0.10]	0.14[0.12]		0.24[0.22]	0.34[0.32]	0.36[0.34]	
	*2 Heating kW	0.04[0.04]		0.05[0.05]	0.07[0.07]	0.09[0.09]	0.10[0.10]	0.12[0.12]		0.22[0.22]	0.32[0.32]	0.34[0.34]	
Current	*2 Cooling A	0.53[0.42]		0.55[0.44]	0.64[0.53]	0.74[0.63]	1.01[0.90]	1.15[1.04]		1.47[1.36]	2.05[1.94]	2.21[2.10]	
	*2 Heating A	0.42[0.42]		0.44[0.44]	0.53[0.53]	0.63[0.63]	0.90[0.90]	1.04[1.04]		1.36[1.36]	1.94[1.94]	2.10[2.10]	
External finish		Galvanized steel plate											
Dimension H x W x D		250 x 700 x 732 (9-7/8" x 27-9/16" x 28-7/8")			250 x 900 x 732 (9-7/8" x 35-7/16" x 28-7/8")			250 x 1,100 x 732 (9-7/8" x 43-5/16" x 28-7/8")			250 x 1,400 x 732 (9-7/8" x 55-1/8" x 28-7/8")		250x1,600x732 (9-7/8" x 63" x 28-7/8")
Net weight		23(51) [22(49)]			26(58) [25(56)]			32(71) [31(69)]			42(93) [41(91)]		46(102) [45(100)]
Heat exchanger		Cross fin (Aluminum fin and copper tube)											
Fan	Type x Quantity		Sirocco fan x 1					Sirocco fan x 2					
	Airflow rate (Lo-Mid-Hi)	m ³ /min	6.0 - 7.5 - 8.5		7.5 - 9.0 - 10.5	10.0 - 12.0 - 14.0	12.0 - 14.5 - 17.0	13.5 - 16.0 - 19.0	14.5 - 18.0 - 21.0		23.0 - 28.0 - 33.0	28.0 - 34.0 - 40.0	29.5 - 35.5 - 42.0
		L/s	100 - 125 - 142		125 - 150 - 175	167 - 200 - 233	200 - 242 - 283	225 - 267 - 317	242 - 300 - 350		383 - 467 - 550	467 - 567 - 667	492 - 592 - 700
		cfm	212 - 265 - 300		265 - 318 - 371	353 - 424 - 494	424 - 512 - 600	477 - 565 - 671	512 - 636 - 742		812 - 989 - 1,165	989 - 1,201 - 1,412	1,042 - 1,254 - 1,483
*4 External static pressure	Pa	<35> - 50 - <70> - <100> - <150>											
Motor	Type		DC brushless motor										
	Output		0.085					0.121			0.244		
Air filter		PP honeycomb fabric.											
Refrigerant pipe diameter	Gas R410A	12.7(1/2")Braze				12.7(1/2")Braze		15.88(5/8")Braze			15.88(5/8")Braze		
	Liquid R410A	6.35(1/4")Braze				6.35(1/4")Braze		9.52(3/8")Braze			9.52(3/8")Braze		
Field drain pipe diameter		O.D.32(1-1/4")											
Noise level (Lo-Mid-Hi)		*2 dBA	23-25-26	23-26-29	23-27-30	25-29-32	25-29-33	26-29-34		28-33-37	32-36-40	33-37-42	

- *1. Nominal cooling conditions
Indoor : 27°CDB/19°CWB(81°FDB/66°FWB), Outdoor : 35°CDB(95°FDB)
Pipe length : 7.5m(24-9/16ft.), Level difference : 0m(0ft.)
- *2. The values are measured at the rated external static pressure.
- *3. Nominal heating conditions.
Indoor : 20°CDB(68°FDB), Outdoor : 7°CDB/6°CWB(45°FDB/43°FWB)
Pipe length : 7.5m(24-9/16ft.), Level difference : 0m(0ft.)
- *4. The rated external static pressure is shown without <>. The factory setting is the rated value.
- NOTE: [] is in case of PEFY-P20~140VMA(L)-E

Optional Parts

Description	Model	Remarks
Filter Box	PAC-KE91TB-E	PEFY-P20/ 25/ 32VMA(L)
	PAC-KE92TB-E	PEFY-P40/ 50VMA(L)
	PAC-KE93TB-E	PEFY-P63/ 71/ 80VMA(L)
	PAC-KE94TB-E	PEFY-P100/ 125VMA(L)
	PAC-KE95TB-E	PEFY-P140VMA(L)



FM 33568 / ISO 9001;2000

The Air Conditioning & Refrigeration Systems Works acquired ISO 9001 certification under Series 9000 of the International Standard Organization (ISO) based on a review of Quality, management for the production of refrigeration and air conditioning equipment.

ISO Authorization System

The ISO 9000 series is a plant authorization system relating to quality management as stipulated by the ISO. ISO 9001 certifies quality management based on the "design, development, production, installation and auxiliary services" for products built at an authorized plant.



Certificate Number EC97J1227

The Air Conditioning & Refrigeration Systems Works acquired environmental management system standard ISO 14001 certification.

The ISO 14000 series is a set of standards applying to environmental protection set by the International Standard Organization (ISO).

