

# SERVICE MANUAL

## Series PCA Ceiling Suspended R407C/R410A

Indoor unit  
[Model Name]

PCA-RP71HAQ

PCA-RP125HAQ

[Service Ref.]

**PCA-RP71HAQ**  
**PCA-RP71HAQ-ER**  
**PCA-RP125HAQ**

Revision:

- Added PCA-RP71HAQR-ER in REVISED EDITION-A.
- Some descriptions have been modified.

- Please void OCH492.

Notes:

- This manual describes service data of the indoor units only.
- RoHS compliant products have <G> mark on the spec name plate.

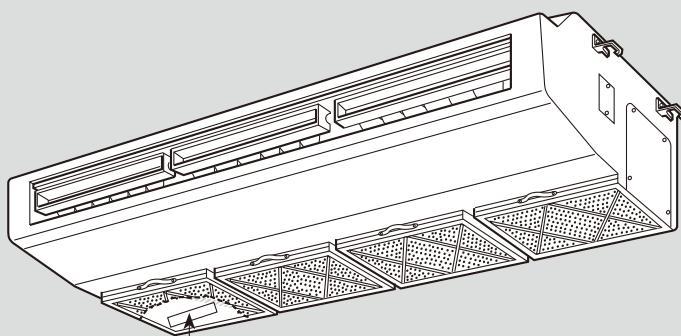

INDOOR UNIT

Model name indication

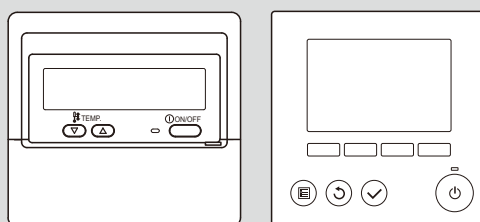

REMOTE CONTROLLER  
(Option)

### CONTENTS

1. REFERENCE MANUAL.....	2
2. SAFETY PRECAUTION.....	3
3. PARTS NAMES AND FUNCTIONS.....	6
4. SPECIFICATIONS.....	10
5. NOISE CRITERION CURVES.....	11
6. OUTLINES AND DIMENSIONS.....	12
7. WIRING DIAGRAM.....	14
8. REFRIGERANT SYSTEM DIAGRAM.....	15
9. TROUBLESHOOTING.....	16
10. SPECIAL FUNCTION.....	27
11. DISASSEMBLY PROCEDURE.....	32

**PARTS CATALOG (OCB492)**

**1-1. OUTDOOR UNIT'S SERVICE MANUAL**

Model Name	Service Ref.	Service Manual No.
PUHZ-RP71VHA4 PUHZ-RP125/140VKA PUHZ-RP125/140/250YKA	PUHZ-RP71VHA4 PUHZ-RP125/140VKA PUHZ-RP125/140/250YKA	OCH451 OCB451
PU(H)-P71VHAR3 PU(H)-P71/125/140YHAR3	PU(H)-P71VHAR3.UK PU(H)-P71/125/140YHAR3.UK	OC379
PUHZ-P125/140VHA3R2 PUHZ-P125/140YHAR1	PUHZ-P125/140VHA3R2.UK PUHZ-P125/140YHAR1.UK	OCH415/OCB415
PUHZ-P250YHA3R2	PUHZ-P250YHA3R2	OCH424/OCB424
PUHZ-ZRP71VHA	PUHZ-ZRP71VHAR1(-ER)	OCH527 OCB527

**1-2. TECHNICAL DATA BOOK**

Series (Outdoor unit)	Manual No.
PUHZ-RP • HA4 PUHZ-RP • KA	OCS16
PUHZ-P • VHA3 PUHZ-P • YHAR3	OCS17
PUHZ-ZRP • VKA	OCS24

**2-1. ALWAYS OBSERVE FOR SAFETY**

**Before obtaining access to terminal, all supply circuits must be disconnected.**

**2-2. CAUTIONS RELATED TO NEW REFRIGERANT**

Caution for units utilising refrigerant R407C

**Do not use the existing refrigerant piping.**

The old refrigerant and lubricant in the existing piping contains a large amount of chlorine which may cause the lubricant deterioration of the new unit.

**Use "low residual oil piping"**

If there is a large amount of residual oil (hydraulic oil, etc.) inside the piping and joints, deterioration of the lubricant will result.

**Store the piping to be used indoors during installation, and keep both ends of the piping sealed until just before brazing. (Leave elbow joints, etc. in their packaging.)**

If dust, dirt, or water enters the refrigerant cycle, deterioration of the oil and compressor trouble may result.

**The refrigerant oil applied to flare and flange connections must be ester oil, ether oil or alkylbenzene oil in a small amount.**

If large amount of mineral oil enter, that can cause deterioration of refrigerant oil, etc.

**Use liquid refrigerant to charge the system.**

If gas refrigerant is used to seal the system, the composition of the refrigerant in the cylinder will change and performance may drop.

**Do not use a refrigerant other than R407C.**

If another refrigerant (R22, etc.) is used, the chlorine in the refrigerant may cause the lubricant deterioration.

**Use a vacuum pump with a reverse flow check valve.**

The vacuum pump oil may flow back into the refrigerant cycle and cause the lubricant deterioration.

**Ventilate the room if refrigerant leaks during operation. If refrigerant comes into contact with a flame, poisonous gases will be released.**

## [1] Cautions for service

- After recovering the all refrigerant in the unit, proceed to working.
- Do not release refrigerant in the air.
- After completing the repair service, recharge the cycle with the specified amount of liquid refrigerant.

## [2] Refrigerant recharging

### (1) Refrigerant recharging process

#### ① Direct charging from the cylinder.

- R407C cylinder available on the market has a syphon pipe.
- Leave the syphon pipe cylinder standing and recharge it.  
(By liquid refrigerant)

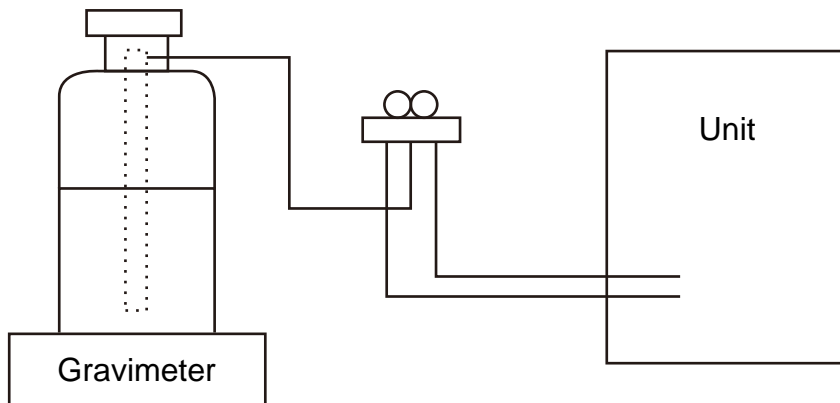

### (2) Recharge in refrigerant leakage case

- After recovering the all refrigerant in the unit, proceed to working.
- Do not release the refrigerant in the air.
- After completing the repair service, recharge the cycle with the specified amount of liquid refrigerant.

## [3] Service tools

Use the below service tools as exclusive tools for R407C refrigerant.

No.	Tool name	Specifications
①	Gauge manifold	<ul style="list-style-type: none"> <li>· Only for R407C</li> <li>· Use the existing fitting SPECIFICATIONS. (UNF7/16)</li> <li>· Use high-tension side pressure of 3.43MPa·G or over.</li> </ul>
②	Charge hose	<ul style="list-style-type: none"> <li>· Only for R407C</li> <li>· Use pressure performance of 5.10MPa·G or over.</li> </ul>
③	Electronic scale	—
④	Gas leak detector	· Use the detector for R134a or R407C.
⑤	Adaptor for reverse flow check	· Attach on vacuum pump.
⑥	Refrigerant charge base	—
⑦	Refrigerant cylinder	<ul style="list-style-type: none"> <li>· For R407C      · Top of cylinder (Brown)</li> <li>· Cylinder with syphon</li> </ul>
⑧	Refrigerant recovery equipment	—

## CAUTIONS RELATED TO NEW REFRIGERANT

### Cautions for units utilising refrigerant R410A

#### Use new refrigerant pipes.

In case of using the existing pipes for R22, be careful with the followings.

- For RP71VHA3 and RP125 be sure to perform replacement operation before test run.
- Change flare nut to the one provided with this product. Use a newly flared pipe.
- Avoid using thin pipes.

**Make sure that the inside and outside of refrigerant piping is clean and it has no contaminants such as sulfur, oxides, dirt, shaving particles, etc, which are hazards to refrigerant cycle. In addition, use pipes with specified thickness.**

Contamination inside refrigerant piping can cause deterioration of refrigerant oil, etc.

**Store the piping to be used during installation indoors, and keep both ends of the piping sealed until just before brazing. (Leave elbow joints, etc. in their packaging.)**

If dirt, dust or moisture enter into refrigerant cycle, that can cause deterioration of refrigerant oil or malfunction of compressor.

**The refrigerant oil applied to flare and flange connections must be ester oil, ether oil or alkylbenzene oil in a small amount.**

If large amount of mineral oil enter, that can cause deterioration of refrigerant oil, etc.

**Charge refrigerant from liquid phase of gas cylinder.**

If the refrigerant is charged from gas phase, composition change may occur in refrigerant and the efficiency will be lowered.

**Do not use refrigerant other than R410A.**

If other refrigerant (R22, etc.) is used, chlorine in refrigerant can cause deterioration of refrigerant oil, etc.

**Use a vacuum pump with a reverse flow check valve.**

Vacuum pump oil may flow back into refrigerant cycle and that can cause deterioration of refrigerant oil, etc.

**Use the following tools specifically designed for use with R410A refrigerant.**

The following tools are necessary to use R410A refrigerant.

Tools for R410A	
Gauge manifold	Flare tool
Charge hose	Size adjustment gauge
Gas leak detector	Vacuum pump adaptor
Torque wrench	Electronic refrigerant charging scale

**Keep the tools with care.**

If dirt, dust or moisture enter into refrigerant cycle, that can cause deterioration of refrigerant oil or malfunction of compressor.

**Do not use a charging cylinder.**

If a charging cylinder is used, the composition of refrigerant will change and the efficiency will be lowered.

**Use the specified refrigerant only.**

**Never use any refrigerant other than that specified.**

Doing so may cause a burst, an explosion, or fire when the unit is being used, serviced, or disposed of.

Correct refrigerant is specified in the manuals and on the spec labels provided with our products.

We will not be held responsible for mechanical failure, system malfunction, unit breakdown or accidents caused by failure to follow the instructions.

**Ventilate the room if refrigerant leaks during operation. If refrigerant comes into contact with a flame, poisonous gases will be released.**

### [1] Cautions for service

- (1) Perform service after collecting the refrigerant left in unit completely.
- (2) Do not release refrigerant in the air.
- (3) After completing service, charge the cycle with specified amount of refrigerant.
- (4) When performing service, install a filter drier simultaneously.  
Be sure to use a filter drier for new refrigerant.

### [2] Additional refrigerant charge

**When charging directly from cylinder**

- Check that cylinder for R410A on the market is syphon type.
- Charging should be performed with the cylinder of syphon stood vertically. (Refrigerant is charged from liquid phase.)

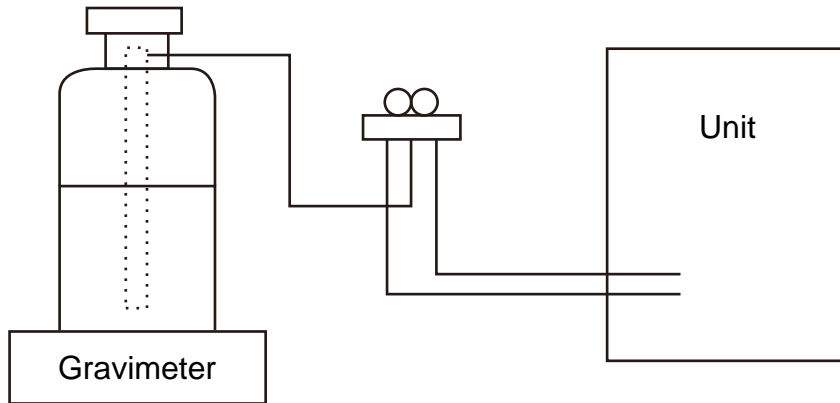

### [3] Service tools

Use the below service tools as exclusive tools for R410A refrigerant.

No.	Tool name	Specifications
①	Gauge manifold	<ul style="list-style-type: none"> <li>· Only for R410A</li> <li>· Use the existing fitting specifications. (UNF1/2)</li> <li>· Use high-tension side pressure of 5.3MPa·G or over.</li> </ul>
②	Charge hose	<ul style="list-style-type: none"> <li>· Only for R410A</li> <li>· Use pressure performance of 5.09MPa·G or over.</li> </ul>
③	Electronic scale	—
④	Gas leak detector	· Use the detector for R134a, R407C or R410A.
⑤	Adaptor for reverse flow check	· Attach on vacuum pump.
⑥	Refrigerant charge base	—
⑦	Refrigerant cylinder	<ul style="list-style-type: none"> <li>· Only for R410A</li> <li>· Top of cylinder (Pink)</li> <li>· Cylinder with syphon</li> </ul>
⑧	Refrigerant recovery equipment	—

## 3

## PARTS NAMES AND FUNCTIONS

### 3-1. Indoor (Main) Unit

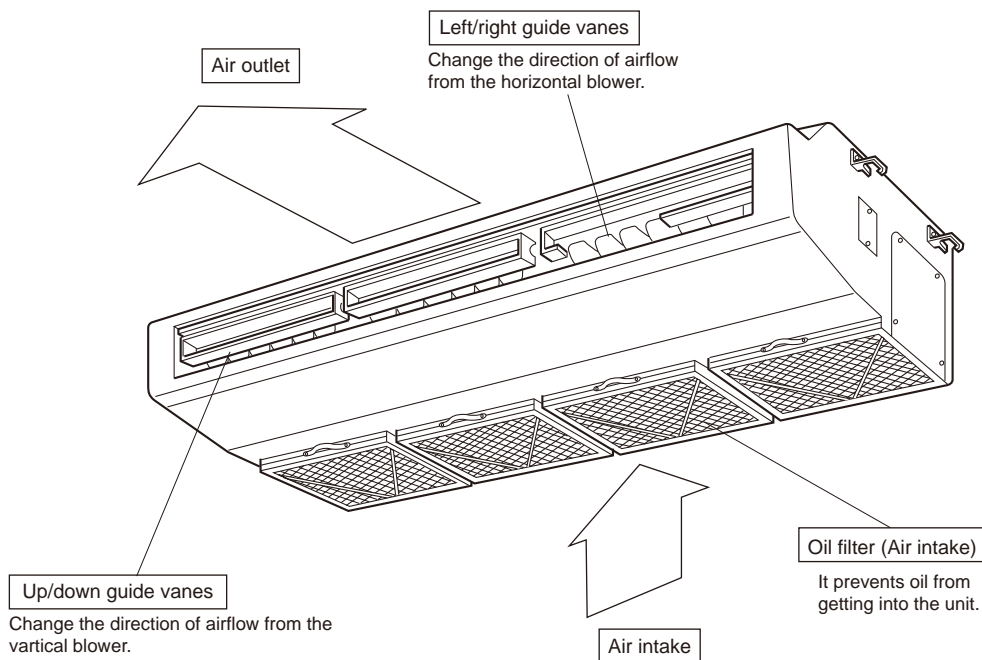

## 3-2. WIRED REMOTE CONTROLLER (OPTION) <PAR-30MAA><PAR-31MAA>

The functions which can be used are restricted according to each model.

### Display

The main display can be displayed in two different modes: "Full" and "Basic."  
The initial setting is "Full."

#### Full mode

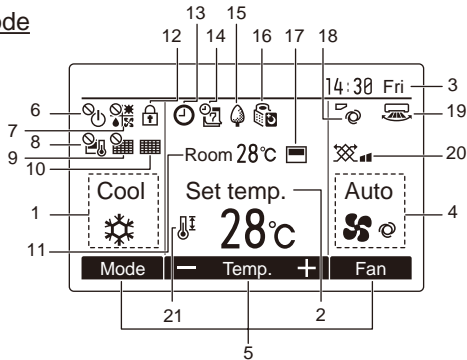

#### Basic mode

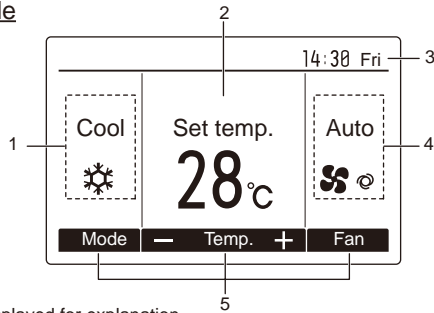

All icons are displayed for explanation.

#### 1 Operation mode

Indoor unit operation mode appears here.

#### 2 Preset temperature

Preset temperature appears here.

#### 3 Clock

(See the Installation Manual.)

Current time appears here.

#### 4 Fan speed

Fan speed setting appears here.

#### 5 Button function guide

Functions of the corresponding buttons appear here.

#### 6

Appears when the ON/OFF operation is centrally controlled.

#### 7

Appears when the operation mode is centrally controlled.

#### 8

Appears when the preset temperature is centrally controlled.

#### 9

Appears when the filter reset function is centrally controlled.

#### 10

Appears when filter needs maintenance.

#### 11 Room temperature

(See the Installation Manual.)

Current room temperature appears here.

#### 12

Appears when the buttons are locked.

#### 13

Appears when the On/Off timer or Night setback function is enabled.

#### 14

Appears when the Weekly timer is enabled.

#### 15

Appears while the units are operated in the energy-save mode.

#### 16

Appears while the outdoor units are operated in the silent mode.

#### 17

Appears when the built-in thermistor on the remote controller is activated to monitor the room temperature.

appears when the thermistor on the indoor unit is activated to monitor the room temperature.

#### 18

Indicates the vane setting.

#### 19

Indicates the louver setting.

#### 20

Indicates the ventilation setting.

#### 21

Appears when the preset temperature range is restricted.

### Controller interface

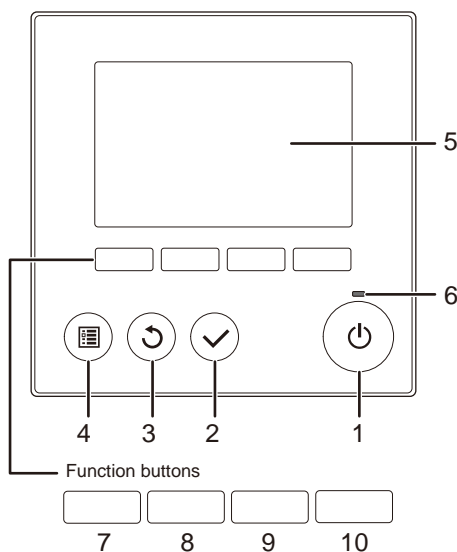

- When the backlight is off, pressing any button turns the backlight on and does not perform its function. (except for the ON/OFF button)
- Most settings (except ON/OFF, mode, fan speed, temperature) can be made from the Menu screen.

#### 1 ON/OFF button

Press to turn ON/OFF the indoor unit.

#### 2 SELECT button

Press to save the setting.

#### 3 RETURN button

Press to return to the previous screen.

#### 4 MENU button

Press to bring up the Main menu.

#### 5 Backlit LCD

Operation settings will appear. When the backlight is off, pressing any button turns the backlight on and it will stay lit for a certain period of time depending on the screen.

#### 6 ON/OFF lamp

This lamp lights up in green while the unit is in operation. It blinks while the remote controller is starting up or when there is an error.

The functions of the function buttons change depending on the screen. Refer to the button function guide that appears at the bottom of the LCD for the functions they serve on a given screen. When the system is centrally controlled, the button function guide that corresponds to the locked button will not appear.

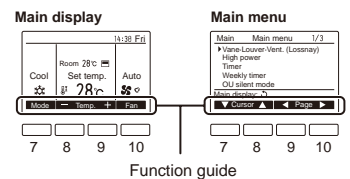

#### 7 Function button F1

Main display: Press to change the operation mode.  
Main menu: Press to move the cursor down.

#### 8 Function button F2

Main display: Press to decrease temperature.  
Main menu: Press to move the cursor up.

#### 9 Function button F3

Main display: Press to increase temperature.  
Main menu: Press to go to the previous page.

#### 10 Function button F4

Main display: Press to change the fan speed.  
Main menu: Press to go to the next page.

## Main menu list

Setting and display items		Setting details
Vane · Louver · Vent. (Lossnay)		<p><b>Use to set the vane angle.</b></p> <ul style="list-style-type: none"> <li>• Select a desired vane setting from five different settings.</li> </ul> <p><b>Use to turn ON / OFF the louver.</b></p> <ul style="list-style-type: none"> <li>• Select a desired setting from "ON" and "OFF."</li> </ul> <p><b>Use to set the amount of ventilation.</b></p> <ul style="list-style-type: none"> <li>• Select a desired setting from "Off," "Low," and "High."</li> </ul>
High power		<p><b>Use to reach the comfortable room temperature quickly.</b></p> <ul style="list-style-type: none"> <li>• Units can be operated in the High-power mode for up to 30 minutes.</li> </ul>
Timer	On/Off timer*	<p><b>Use to set the operation On/Off times.</b></p> <ul style="list-style-type: none"> <li>• Time can be set in 5-minute increments.</li> </ul>
	Auto-Off timer	<p><b>Use to set the Auto-Off time.</b></p> <ul style="list-style-type: none"> <li>• Time can be set to a value from 30 to 240 in 10-minute increments.</li> </ul>
Weekly timer*		<p><b>Use to set the weekly operation On / Off times.</b></p> <ul style="list-style-type: none"> <li>• Up to eight operation patterns can be set for each day. (Not valid when the On/Off timer is enabled.)</li> </ul>
Restriction	Temp. range	<p><b>Use to restrict the preset temperature range.</b></p> <ul style="list-style-type: none"> <li>• Different temperature ranges can be set for different operation modes.</li> </ul>
	Operation lock	<p><b>Use to lock selected functions.</b></p> <ul style="list-style-type: none"> <li>• The locked functions cannot be operated.</li> </ul>
Energy saving	Auto return	<p><b>Use to get the units to operate at the preset temperature after performing energy-save operation for a specified time period.</b></p> <ul style="list-style-type: none"> <li>• Time can be set to a value from 30 and 120 in 10-minute increments. (This function will not be valid when the preset temperature ranges are restricted.)</li> </ul>
	Schedule*	<p><b>Set the start/stop times to operate the units in the energy-save mode for each day of the week, and set the energy-saving rate.</b></p> <ul style="list-style-type: none"> <li>• Up to four energy-save operation patterns can be set for each day.</li> <li>• Time can be set in 5-minute increments.</li> <li>• Energy-saving rate can be set to a value from 0% or 50 to 90% in 10% increments.</li> </ul>
Night setback*		<p><b>Use to make Night setback settings.</b></p> <ul style="list-style-type: none"> <li>• Select "Yes" to enable the setting, and "No" to disable the setting. The temperature range and the start/stop times can be set.</li> </ul>
Filter information		<p><b>Use to check the filter status.</b></p> <ul style="list-style-type: none"> <li>• The filter sign can be reset.</li> </ul>
Error information		<p><b>Use to check error information when an error occurs.</b></p> <ul style="list-style-type: none"> <li>• Check code, error source, refrigerant address, unit model, manufacturing number, contact information (dealer's phone number) can be displayed. (The unit model, manufacturing number, and contact information need to be registered in advance to be displayed.)</li> </ul>
Maintenance	Auto descending panel	Auto descending panel (Optional parts) Up / Down you can do.
	Manual vane angle	Use to set the vane angle for each vane to a fixed position.
Initial setting	Main/Sub	When connecting two remote controllers, one of them needs to be designated as a sub controller.
	Clock	Use to set the current time.
	Main display	Use to switch between "Full" and "Basic" modes for the Main display. • The initial setting is "Full."
	Contrast	Use to adjust screen contrast.
	Display details	<p>Make the settings for the remote controller related items as necessary.</p> <p><b>Clock:</b> The initial settings are "Yes" and "24h" format.  <b>Temperature:</b> Set either Celsius (°C) or Fahrenheit (°F).  <b>Room temp. :</b> Set Show or Hide.  <b>Auto mode:</b> Set the Auto mode display or Only Auto display.</p>
	Auto mode	<p>Whether or not to use the Auto mode can be selected by using the button.</p> <p>This setting is valid only when indoor units with the Auto mode function are connected.</p>
	Administrator password	<p>The administrator password is required to make the settings for the following items.</p> <ul style="list-style-type: none"> <li>• Timer setting</li> <li>• Energy-save setting</li> <li>• Weekly timer setting</li> <li>• Restriction setting</li> <li>• Outdoor unit silent mode setting</li> <li>• Night set back</li> </ul>
	Language selection	Use to select the desired language.
Service	Test run	<p>Select "Test run" from the Service menu to bring up the Test run menu.</p> <ul style="list-style-type: none"> <li>• Test run</li> <li>• Drain pump test run</li> </ul>
	Input maintenance	<p>Select "Input maintenance Info." from the Service menu to bring up the Maintenance information screen. The following settings can be made from the Maintenance Information screen.</p> <ul style="list-style-type: none"> <li>• Model name input</li> <li>• Serial No. input</li> <li>• Dealer information input</li> </ul>
	Function setting	Make the settings for the indoor unit functions via the remote controller as necessary.
	Check	<p><b>Error history:</b> Display the error history and execute "delete error history".</p> <p><b>Refrigerant leak check:</b> Refrigerant leaks can be judged.</p> <p><b>Smooth maintenance:</b> The indoor and outdoor maintenance data can be displayed.</p> <p><b>Request code:</b> Details of the operation data including each thermistor temperature and error history can be checked.</p>
	Self check	Error history of each unit can be checked via the remote controller.
	Maintenance password	Take the following steps to change the maintenance password.
	Remote controller check	When the remote controller does not work properly, use the remote controller checking function to troubleshoot the problem.

\*Clock setting is required.



### 3-3. WIRED REMOTE CONTROLLER (OPTION) <PAR-21MAA>

The functions which can be used are restricted according to each model.

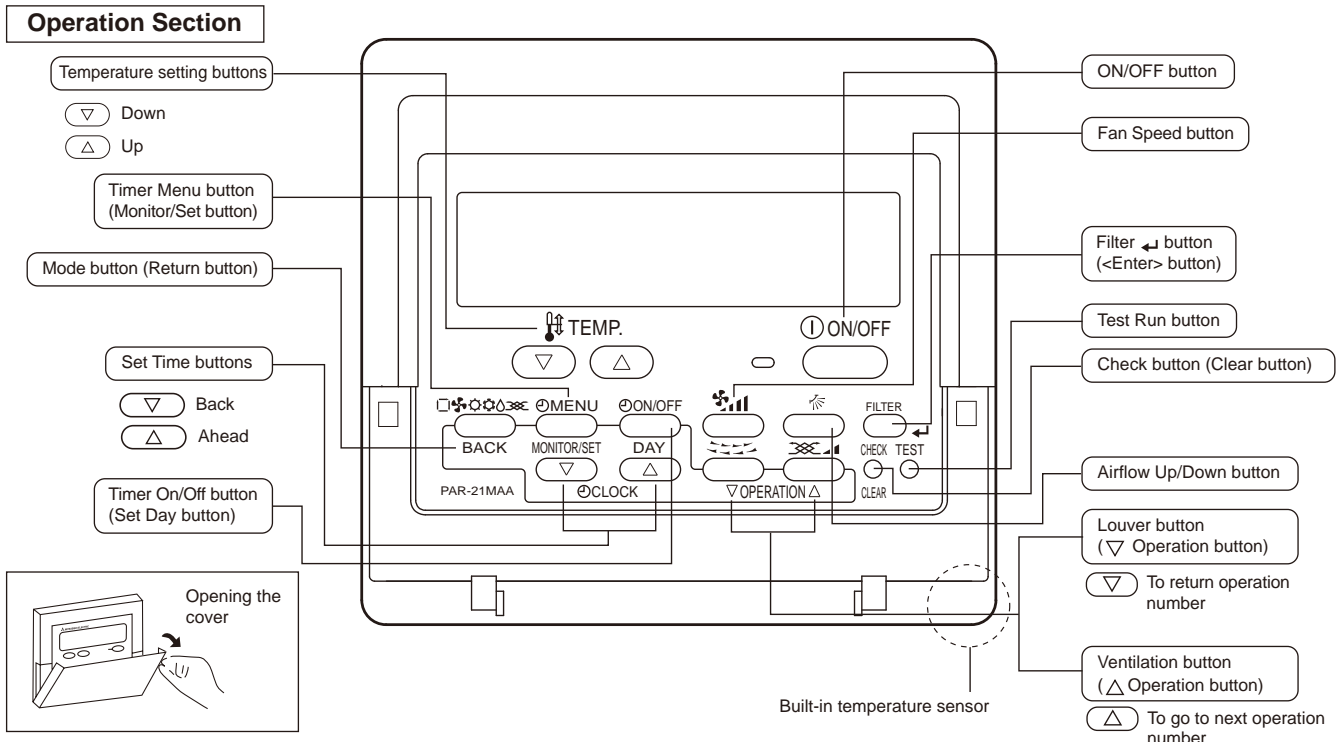
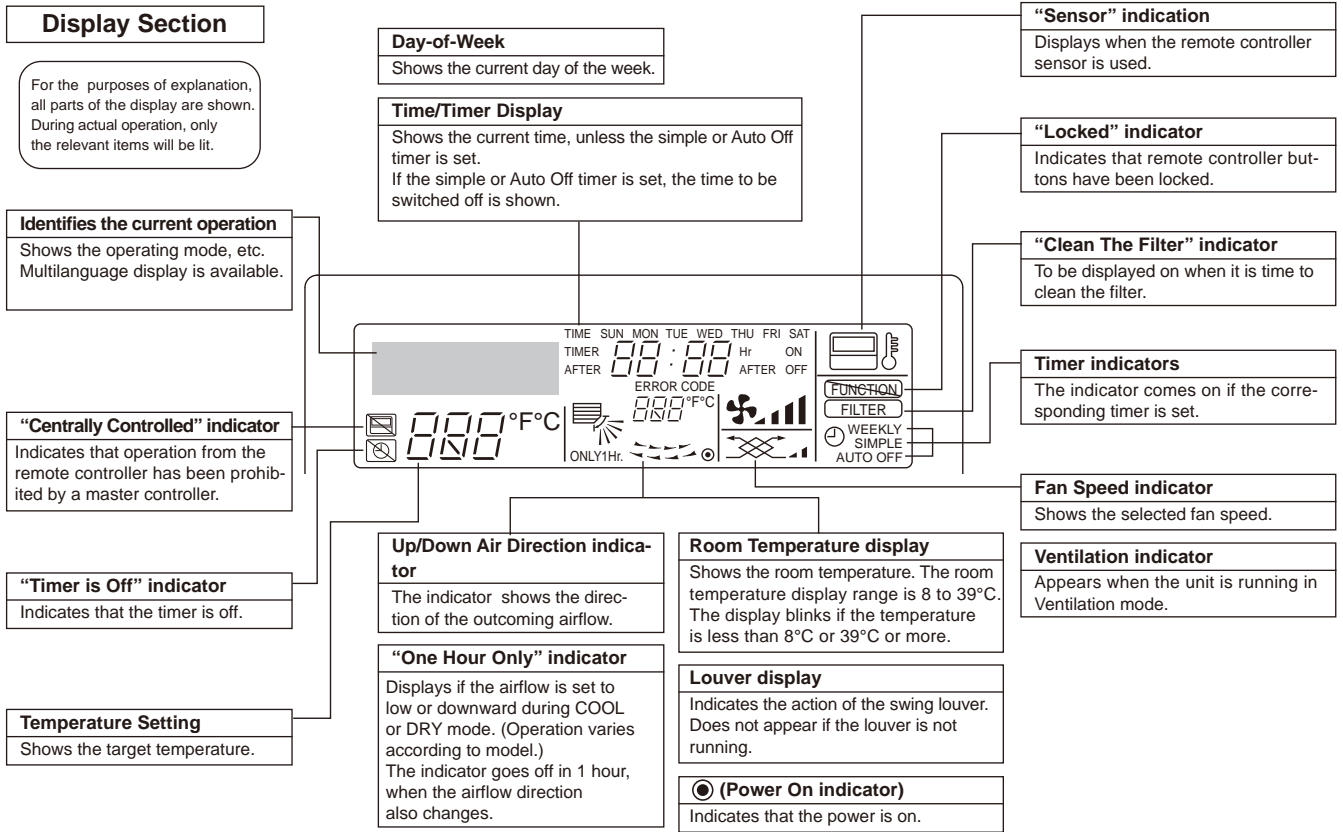

**Caution:**

- Only the Power on indicator lights when the unit is stopped and power supplied to the unit.
- If you press a button for a feature that is not installed at the indoor unit, the remote controller will display the "Not Available" message.  
 If you are using the remote controller to drive multiple indoor units, this message will appear only if the feature is not present at every unit connected.
- When power is turned ON for the first time, it is normal that "PLEASE WAIT" is displayed on the room temperature indication (For max. 2 minutes). Please wait until this "PLEASE WAIT" indication disappears then start the operation.

# 4

# SPECIFICATIONS

Service Ref.			PCA-RP71HAQ	
			PCA-RP71HAQ-ER	
Mode			Cooling	Heating
Power supply (phase, cycle, voltage)			Single phase, 50Hz, 230V	
INDOOR UNIT	Input	kW	0.09	0.09
	Running current	A	0.43	0.43
	Starting current	A	0.86	0.86
External finish			Stainless steel	
Heat exchanger			Plate fin coil	
INDOOR UNIT	Fan	Fan (drive) x No.	Sirocco fan (direct) x 2	
		Fan motor output	kW	
		Airflow (Low-High)	m <sup>3</sup> /min (CFM)	
		External static pressure	Pa (mmAq)	
Operation control & Thermostat			Remote controller & built-in	
Noise level (Low-High)		dB	34-38	
Unit drain pipe I.D.		mm (in)	26 (1)	
Dimensions	W	mm (in)	1,136 (44-3/4)	
	D	mm (in)	650 (25-5/8)	
	H	mm (in)	280 (11)	
Weight		kg (lb)	41 (90)	

Service Ref.			PCA-RP125HAQ	
			Mode	
Power supply (phase, cycle, voltage)			Single phase, 50Hz, 230V	
INDOOR UNIT	Input	kW	0.26	0.26
	Running current	A	1.19	1.19
	Starting current	A	2.38	2.38
External finish			Stainless steel	
Heat exchanger			Plate fin coil	
INDOOR UNIT	Fan	Fan (drive) x No.	Sirocco fan (direct) x 4	
		Fan motor output	kW	
		Airflow (Low-High)	m <sup>3</sup> /min (CFM)	
		External static pressure	Pa(mmAq)	
Operation control & Thermostat			Remote controller & built-in	
Noise level (Low-High)		dB	44-50	
Unit drain pipe I.D.		mm (in)	26 (1)	
Dimensions	W	mm (in)	1,520 (59-7/8)	
	D	mm (in)	650 (25-5/8)	
	H	mm (in)	280 (11)	
Weight		kg (lb)	56 (124)	

# 5

# NOISE CRITERION CURVES

**PCA-RP71HAQ  
PCA-RP71HAQ-ER**

NOTCH	SPL(dB)	LINE
High	38	○—○
Low	34	●—●

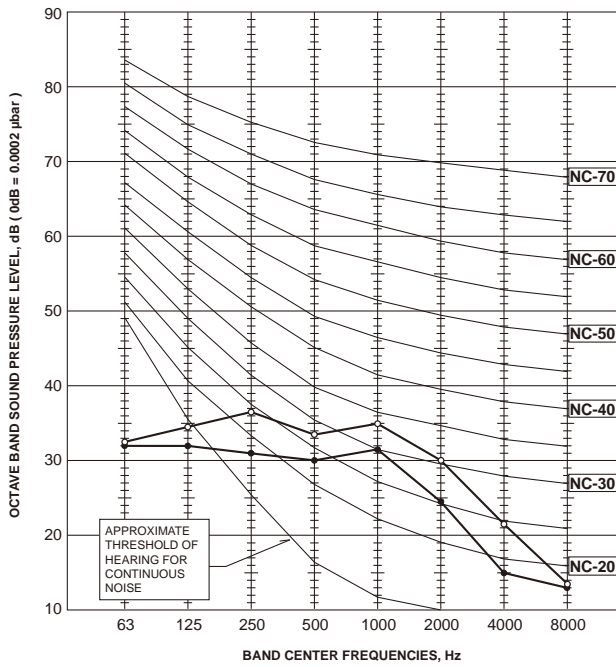

**PCA-RP125HAQ**

NOTCH	SPL(dB)	LINE
High	50	○—○
Low	44	●—●

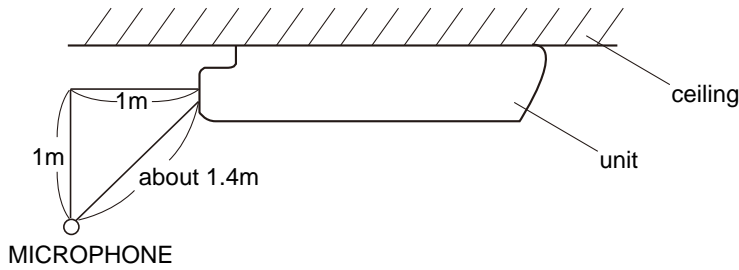
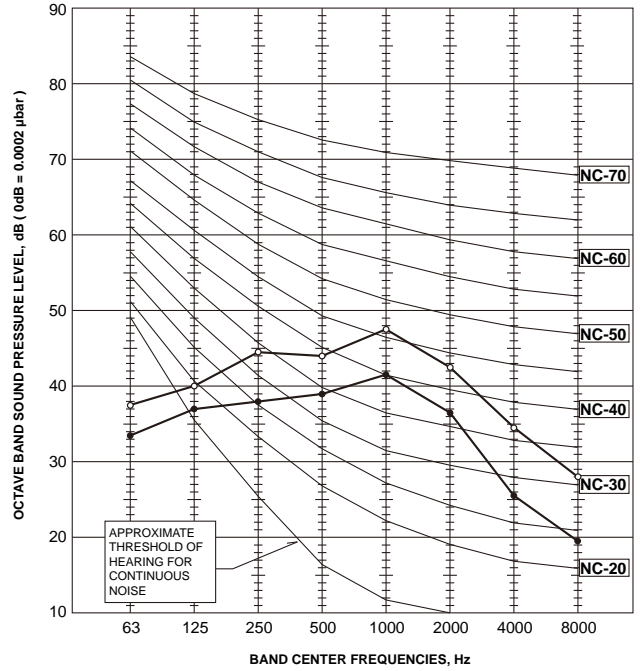



# PCA-RP125HAQ

Unit: mm

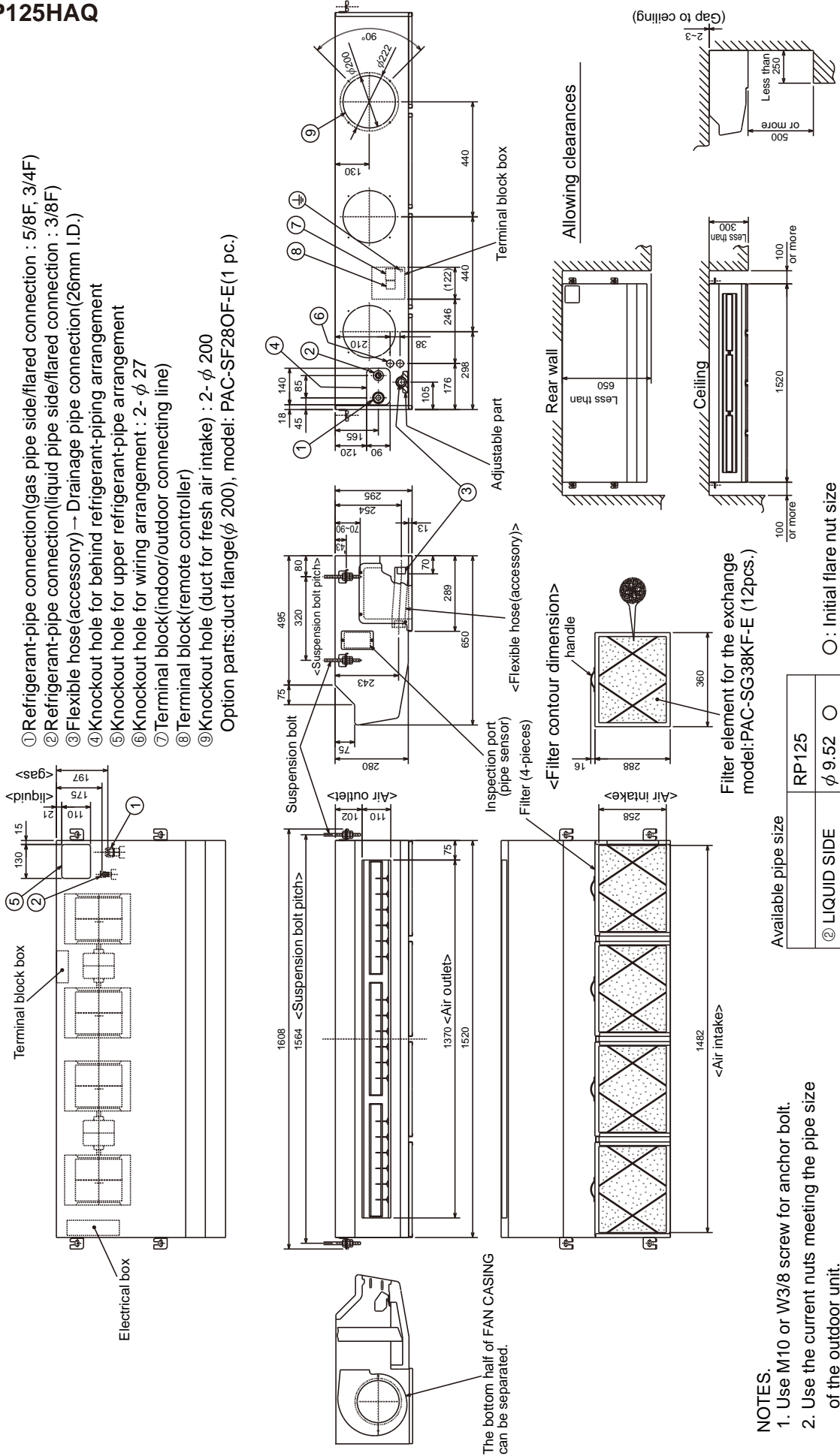

- ① Refrigerant-pipe connection (gas pipe side/flared connection : 5/8F, 3/4F)
  - ② Refrigerant-pipe connection (liquid pipe side/flared connection : 3/8F)
  - ③ Flexible hose (accessory) → Drainage pipe connection (26mm I.D.)
  - ④ Knockout hole for behind refrigerant-piping arrangement
  - ⑤ Knockout hole for upper refrigerant-pipe arrangement
  - ⑥ Knockout hole for wiring arrangement : 2- $\phi$  27
  - ⑦ Terminal block (indoor/outdoor connecting line)
  - ⑧ Terminal block (remote controller)
  - ⑨ Knockout hole (duct for fresh air intake) : 2- $\phi$  200
- Option parts: duct flange ( $\phi$  200), model: PAC-SF28OF-E (1 pc.)

NOTES.  
 1. Use M10 or W3/8 screw for anchor bolt.  
 2. Use the current nuts meeting the pipe size of the outdoor unit.

Available pipe size	RP125
② LIQUID SIDE	$\phi$ 9.52 ○
① GAS SIDE	$\phi$ 15.88 ○
	$\phi$ 19.05

○ : Initial flare nut size

PCA-RP71HAQ  
PCA-RP71HAQ-ER

PCA-RP125HAQ

[LEGEND]

SYMBOL	NAME	SYMBOL	NAME
P. B	INDOOR POWER BOARD	MF1, MF2	FAN MOTOR
I. B	INDOOR CONTROLLER BOARD	C1, C2	CAPACITOR (FAN MOTOR)
	FUSE (T6.3AL250V)	H2	DEW PREVENTION HEATER
	CN2L CONNECTOR (LOSSNAY)	TB2	TERMINAL BLOCK (INDOOR UNIT POWER (OPTION PARTS))
	CN32 CONNECTOR (REMOTE SWITCH)	TB4	TERMINAL BLOCK (INDOOR/OUTDOOR CONNECTING LINE)
	CN41 CONNECTOR (HA TERMINAL-A)	TB5, TB6	TERMINAL BLOCK (REMOTE CONTROLLER TRANSMISSION LINE)
	CN51 CONNECTOR (CENTRALLY CONTROLL)	TH1	ROOM TEMP.THERMISTOR (0°C/15kΩ, 25°C/5.4kΩ DETECT)
	LED1 POWER SUPPLY (L. B)	TH2	PIPE TEMP.THERMISTOR/LIQUID (0°C/15kΩ, 25°C/5.4kΩ DETECT)
	LED2 POWER SUPPLY (R. B)	TH5	COND./EVA.TEMP.THERMISTOR (0°C/15kΩ, 25°C/5.4kΩ DETECT)
	LED3 TRANSMISSION (INDOOR-OUTDOOR)	R. B	WIRED REMOTE CONTROLLER BOARD
	X1 RELAY (DEW PREVENTION HEATER)		
	X4 RELAY (FAN MOTOR)		
	X5 RELAY (FAN MOTOR)		
	X6 RELAY (FAN MOTOR)		
	SW1 SWITCH (MODEL SELECTION) *See Table 1.		
	SW2 SWITCH (CAPACITY CODE) *See Table 2.		
	SWE SWITCH (EMERGENCY OPERATION)		

Check code	Symptom
P1	Abnormality of room temperature thermistor (TH1)
P2	Abnormality of pipe temperature thermistor/Liquid (TH2)
P6	Freezing/overheating protection is working.
P8	Abnormality of pipe temperature
P9	Abnormality of pipe temperature thermistor/Cond.Eva. (TH5)
E0 - E5	Abnormality of the signal transmission between remote controller and indoor unit
E6 - EF	Abnormality of the signal transmission between indoor unit and outdoor unit
Fb	Abnormality of indoor controller board
U*, F*	Abnormality in outdoor unit. Refer to outdoor unit wiring diagram.
----	No trouble generated in the past.
FFFF	No corresponding unit

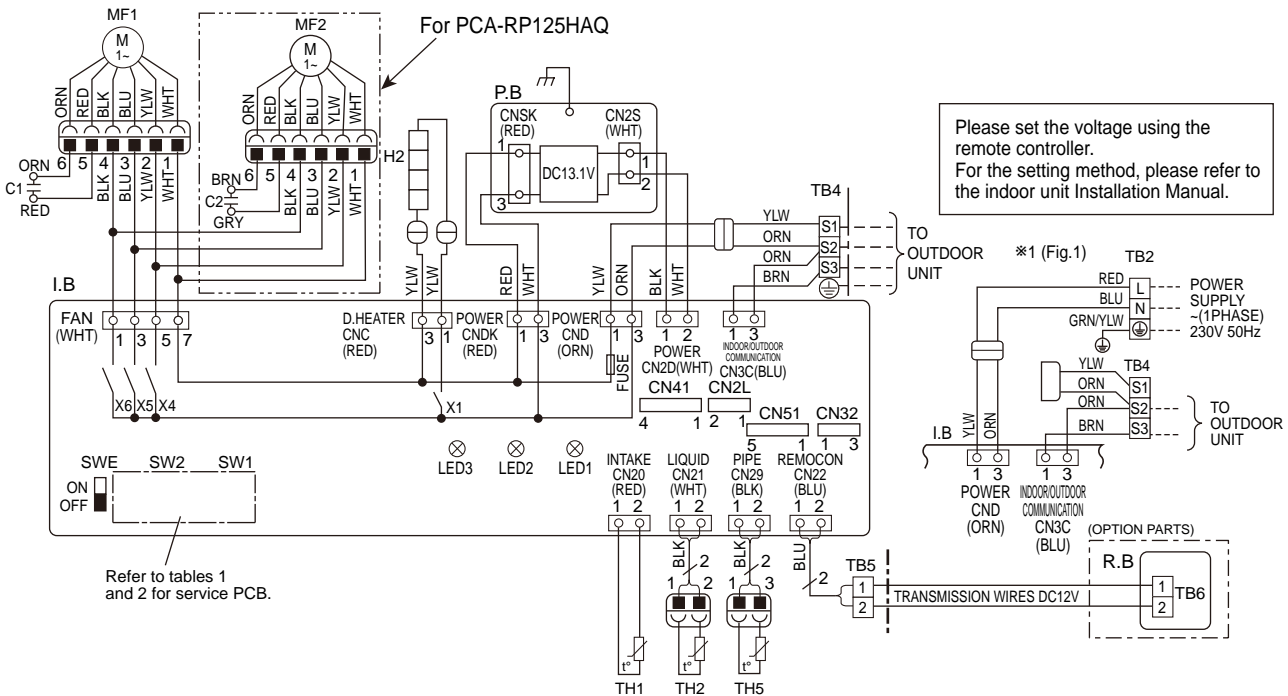

Table 1

SW1				
Service board				
1	2	3	4	5
■	■	■	■	■
				ON
				OFF

Table 2

		SW2						
MODELS	Service board	MODELS	Service board					
PCA-RP71HAQ	1 2 3 4 5	PCA-RP125HAQ	1	2	3	4	5	
	■ ■ ■ ■ ■		■	■	■	■	■	
							ON	
							OFF	

The black square (■) indicates a switch position.

NOTES:

- Since the outdoor side electric wiring may change be sure to check the outdoor unit electric wiring for servicing.
  - Indoor and outdoor connecting wires are made with polarities, make wiring matching terminal numbers (S1,S2,S3).
  - Symbols used in wiring diagram above are, : Connector, : Terminal (block).
- \*1 When work to supply power separately to Indoor and Outdoor unit was applied, refer to Fig1.  
\*2 For power supply system of this unit, refer to the caution label located near this diagram.

# 8

# REFRIGERANT SYSTEM DIAGRAM

PCA-RP71HAQ  
PCA-RP71HAQ-ER

PCA-RP125HAQ

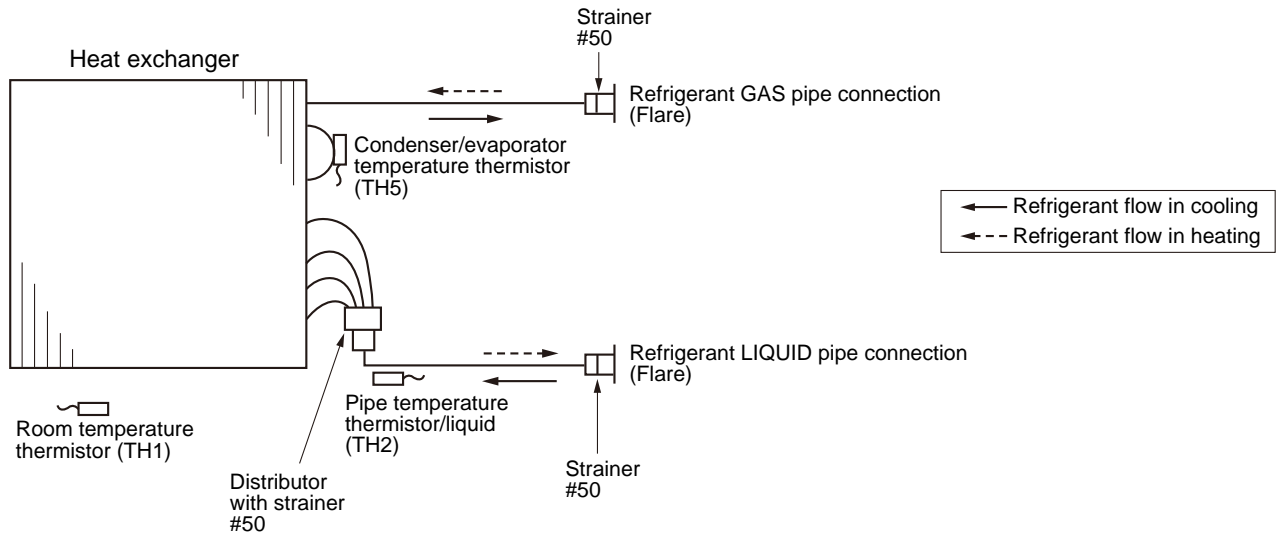

### 9-1. TROUBLESHOOTING

#### <Check code displayed by self-diagnosis and actions to be taken for service (summary)>

Present and past check codes are logged, and they displayed on the wired remote controller or controller board of outdoor unit. Actions to be taken for service, which depends on whether or not the trouble is reoccurring in the field, are summarized in the table below. Check the contents below before investigating details.

Note : Refer to the manual of outdoor unit for malfunction-diagnosis method by remote controller.

Unit conditions at service	Check code	Actions to be taken for service (summary)
The trouble is reoccurring.	Displayed	Judge what is wrong and take a corrective action according to "9-2.SELF-DIAGNOSIS ACTION TABLE".
	Not displayed	Conduct troubleshooting and ascertain the cause of the trouble according to "9-3. TROUBLESHOOTING BY INFERIOR PHENOMENA".
The trouble is not reoccurring.	Logged	①Consider the temporary defects such as the work of protection devices in the refrigerant circuit including compressor, poor connection of wiring, noise, etc. Re-check the symptom, and check the installation environment, refrigerant amount, weather when the trouble occurred, and wiring related. ②Reset check code logs and restart the unit after finishing service. ③There is no abnormality in electrical components, controller boards, and remote controller.
	Not logged	①Recheck the abnormal symptom. ②Identify the cause of the trouble and take a corrective action according to "9-3. TROUBLESHOOTING BY INFERIOR PHENOMENA". ③Continue to operate unit for the time being if the cause is not ascertained. ④There is no abnormality in electrical components, controller boards, remote controller, etc.



Note:

Errors to be detected in outdoor unit, such as codes starting with F, U or E (excluding E0 to E7), are not covered in this document. Please refer to the outdoor unit's service manual for the details.

## 9-2. SELF-DIAGNOSIS ACTION TABLE

Check Code	Abnormal point and detection method	Cause	Countermeasure										
P1	<p><b>Room temperature thermistor (TH1)</b></p> <p>① The unit is in 3-minute resume prevention mode if short/open of thermistor is detected. Abnormal if the unit does not reset normally after 3 minutes. (The unit returns to normal operation, if it has been reset normally.)</p> <p>② Constantly detected during cooling, drying, and heating operation. Short: -90°C or more Open: -40°C or less</p>	<p>① Defective thermistor characteristics</p> <p>② Contact failure of connector (CN20) on the indoor controller board (Insert failure)</p> <p>③ Breaking of wire or contact failure of thermistor wiring</p> <p>④ Defective indoor controller board</p>	<p>①-③ Check resistance value of thermistor.</p> <table border="0"> <tr> <td>0°C</td> <td>15.0 kΩ</td> </tr> <tr> <td>10°C</td> <td>9.6 kΩ</td> </tr> <tr> <td>20°C</td> <td>6.3 kΩ</td> </tr> <tr> <td>30°C</td> <td>4.3 kΩ</td> </tr> <tr> <td>40°C</td> <td>3.0 kΩ</td> </tr> </table> <p>If you put force on (draw or bend) the lead wire with measuring resistance value of thermistor, breaking of wire or contact failure can be detected.</p> <p>② Check contact failure of connector (CN20) on the indoor controller board. Refer to "9-6. TEST POINT DIAGRAM". Turn the power on again and check restart after inserting connector again.</p> <p>④ Check room temperature display on remote controller. Replace indoor controller board if there is abnormal difference with actual room temperature. Turn the power off, and on again to operate after check.</p>	0°C	15.0 kΩ	10°C	9.6 kΩ	20°C	6.3 kΩ	30°C	4.3 kΩ	40°C	3.0 kΩ
0°C	15.0 kΩ												
10°C	9.6 kΩ												
20°C	6.3 kΩ												
30°C	4.3 kΩ												
40°C	3.0 kΩ												
P2	<p><b>Pipe temperature thermistor/Liquid (TH2)</b></p> <p>① The unit is in 3-minute resume prevention mode if short/open of thermistor is detected. Abnormal if the unit does not reset normally after 3 minutes. (The unit returns to normal operation, if it has been reset normally.)</p> <p>② Constantly detected during cooling, drying, and heating (except defrosting) operation. Short: 90°C or more Open: -40°C or less</p>	<p>① Defective thermistor characteristics</p> <p>② Contact failure of connector (CN44) on the indoor controller board (Insert failure)</p> <p>③ Breaking of wire or contact failure of thermistor wiring</p> <p>④ Defective refrigerant circuit is causing thermistor temperature of 90°C or more or 3-40°C or less.</p> <p>⑤ Defective indoor controller board</p>	<p>①-③ Check resistance value of thermistor. For characteristics, refer to (P1) above.</p> <p>② Check contact failure of connector (CN44) on the indoor controller board. Refer to "9-6. TEST POINT DIAGRAM". Turn the power on and check restart after inserting connector again.</p> <p>④ Check pipe &lt;liquid&gt; temperature with remote controller in test run mode. If pipe &lt;liquid&gt; temperature is extremely low (in cooling mode) or high (in heating mode), refrigerant circuit may have defective.</p> <p>⑤ Check pipe &lt;liquid&gt; temperature with remote controller in test run mode. If there is extremely difference with actual pipe &lt;liquid&gt; temperature, replace indoor controller board. Turn the power off, and on again to operate after check.</p>										
P4	<p><b>Drain sensor (DS)</b></p> <p>① Suspensive abnormality, if short/open of thermistor is detected for 30 seconds continuously. Compressor and indoor fan will be turned off</p> <p>② Short/open is detected for 30 seconds continuously during suspensive abnormality. (The unit returns to normal operation, if it has normally reset.)</p> <p>③ Detect the following condition.</p> <ul style="list-style-type: none"> <li>• During cooling and drying operation.</li> <li>• In case that pipe &lt;liquid&gt; temperature - room temperature &lt;-10°C (Except defrosting)</li> <li>• When pipe &lt;liquid&gt; temperature or room temperature is short/open temperature.</li> <li>• During drain pump operation.</li> </ul>	<p>① Defective thermistor characteristics</p> <p>② Contact failure of connector (CN31) on the indoor controller board (Insert failure)</p> <p>③ Breaking of wire or contact failure of drain sensor wiring</p> <p>④ Defective indoor controller board</p>	<p>①-③ Check resistance value of thermistor.</p> <table border="0"> <tr> <td>0°C</td> <td>.....6.0 kΩ</td> </tr> <tr> <td>10°C</td> <td>....3.9 kΩ</td> </tr> <tr> <td>20°C</td> <td>...2.6 kΩ</td> </tr> <tr> <td>30°C</td> <td>...1.8 kΩ</td> </tr> <tr> <td>40°C</td> <td>...1.3 kΩ</td> </tr> </table> <p>② Check contact failure of connector (CN31) on the indoor controller board. Refer to "9-6. TEST POINT DIAGRAM". Turn the power on again and check restart after inserting connector again.</p> <p>④ Replace indoor controller board if drain pump operates with the line of drain sensor connector CN31-① and ② is short-circuited, and abnormality reappears. Turn the power off, and on again to operate after check.</p>	0°C	.....6.0 kΩ	10°C	....3.9 kΩ	20°C	...2.6 kΩ	30°C	...1.8 kΩ	40°C	...1.3 kΩ
0°C	.....6.0 kΩ												
10°C	....3.9 kΩ												
20°C	...2.6 kΩ												
30°C	...1.8 kΩ												
40°C	...1.3 kΩ												
P5	<p><b>Malfunction of drain pump (DP)</b></p> <p>① Suspensive abnormality, if thermistor of drain sensor is let heat itself and temperature rises slightly. Compressor and indoor fan will be turned off.</p> <p>② Drain pump is abnormal if the condition above is detected during suspensive abnormality.</p> <p>③ Constantly detected during drain pump operation.</p>	<p>① Malfunction of drain pump</p> <p>② Defective drain Clogged drain pump Clogged drain pipe</p> <p>③ Attached drop of water at the drain sensor</p> <ul style="list-style-type: none"> <li>• Drops of drain trickles from lead wire</li> <li>• Clogged filter is causing wave of drain.</li> </ul> <p>④ Defective indoor controller board</p>	<p>① Check if drain pump operates.</p> <p>② Check drain function.</p> <p>③ Check the setting of lead wire of drain sensor and check clogs of the filter.</p> <p>④ Replace indoor controller board if drain pump operates with the line of drain sensor connector CN31-① and ② is short-circuited and abnormality reappears. Refer to "9-6. TEST POINT DIAGRAM". Turn the power off, and on again to operate after check.</p>										



Check Code	Abnormal point and detection method	Cause	Countermeasure
P6	<p><b>Freezing/overheating protection is operating</b></p> <p>① Freezing protection (Cooling mode) The unit is in 6-minute resume prevention mode if pipe &lt;liquid or condenser/ evaporator&gt; temperature stays under -15°C for 3 minutes, 3 minutes after the compressor started. Abnormal if it stays under -15°C for 3 minutes again within 16 minutes after 6-minute resume prevention mode.</p> <p>② Overheating protection (Heating mode) The units is in 6-minute resume prevention mode if pipe &lt;condenser / evaporator&gt; temperature is detected as over 70°C after the compressor started. Abnormal if the temperature of over 70°C is detected again within 30 minutes after 6-minute resume prevention mode.</p>	<p>(Cooling or drying mode)</p> <p>① Clogged filter (reduced airflow) ② Short cycle of air path ③ Low-load (low temperature) operation out of the tolerance range ④ Defective indoor fan motor • Fan motor is defective. • Indoor controller board is defective.</p> <p>⑤ Defective outdoor fan control ⑥ Overcharge of refrigerant ⑦ Defective refrigerant circuit (clogs)</p> <p>(Heating mode)</p> <p>① Clogged filter (reduced airflow) ② Short cycle of air path ③ Over-load (high temperature) operation out of the tolerance range ④ Defective indoor fan motor • Fan motor is defective. • Indoor controller board is defective. ⑤ Defective outdoor fan control ⑥ Overcharge of refrigerant ⑦ Defective refrigerant circuit (clogs) ⑧ Bypass circuit of outdoor unit is defective.</p>	<p>(Cooling or drying mode)</p> <p>① Check clogs of the filter. ② Remove blockage.</p> <p>④ Refer to "9-5. HOW TO CHECK THE PARTS".</p> <p>⑤ Check outdoor fan motor. ⑥⑦ Check operating condition of refrigerant circuit.</p> <p>(Heating mode)</p> <p>① Check clogs of the filter. ② Remove blockage.</p> <p>④ Refer to "9-5. HOW TO CHECK THE PARTS".</p> <p>⑤ Check outdoor fan motor. ⑥-⑧ Check operating condition of refrigerant circuit.</p>
P8	<p><b>Pipe temperature</b> &lt;Cooling mode&gt; Detected as abnormal when the pipe temperature is not in the cooling range 3 minutes after compressor start and 6 minutes after the liquid or condenser/evaporator pipe is out of cooling range. Note 1: It takes at least 9 minutes to detect. Note 2: Abnormality P8 is not detected in drying mode. Cooling range : -3 °C ≧ (TH-TH1) TH: Lower temperature between liquid pipe temperature (TH2) and condenser/ evaporator temperature (TH5) TH1: Intake temperature</p> <p>&lt;Heating mode&gt; When 10 seconds have passed after the compressor starts operation and the hot adjustment mode has finished, the unit is detected as abnormal when condenser/ evaporator pipe temperature is not in heating range within 20 minutes.</p> <p>Note 3: It takes at least 27 minutes to detect abnormality. Note 4: It excludes the period of defrosting. (Detection restarts when defrosting mode is over.) Heating range : 3 °C ≦ (TH5-TH1)</p>	<p>① Slight temperature difference between indoor room temperature and pipe &lt;liquid or condenser / evaporator&gt; temperature thermistor • Shortage of refrigerant • Disconnected holder of pipe &lt;liquid or condenser / evaporator&gt; thermistor • Defective refrigerant circuit</p> <p>② Converse connection of extension pipe (on plural units connection)</p> <p>③ Converse wiring of indoor/ outdoor unit connecting wire (on plural units connection)</p> <p>④ Defective detection of indoor room temperature and pipe &lt;condenser / evaporator&gt; temperature thermistor</p> <p>⑤ Stop valve is not opened completely.</p>	<p>①-④ Check pipe &lt;liquid or condenser / evaporator&gt; temperature with room temperature display on remote controller and outdoor controller circuit board. Pipe &lt;liquid or condenser / evaporator&gt; temperature display is indicated by setting SW2 of outdoor controller circuit board as follows.</p> <p>( Conduct temperature check with outdoor controller circuit board after connecting 'A-Control Service Tool(PAC-SK52ST)' )</p> <p>②③ Check converse connection of extension pipe or converse wiring of indoor/outdoor unit connecting wire.</p>

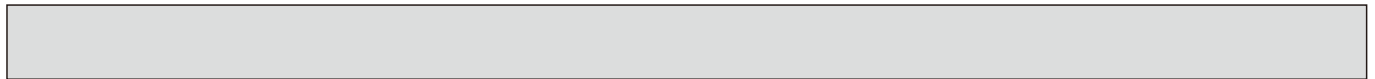

Check Code	Abnormal point and detection method	Cause	Countermeasure
P9	<p><b>Pipe temperature thermistor / Condenser-Evaporator (TH5)</b></p> <p>① The unit is in 3-minute resume protection mode if short/open of thermistor is detected. Abnormal if the unit does not get back to normal within 3 minutes. (The unit returns to normal operation, if it has been reset normally.)</p> <p>② Constantly detected during cooling, drying, and heating operation (except defrosting) Short: 90°C or more Open: -40°C or less</p>	<p>① Defective thermistor characteristics</p> <p>② Contact failure of connector (CN44) on the indoor controller board (Insert failure)</p> <p>③ Breaking of wire or contact failure of thermistor wiring</p> <p>④ Temperature of thermistor is 90°C or more or -40°C or less caused by defective refrigerant circuit.</p> <p>⑤ Defective indoor controller board</p>	<p>①-③ Check resistance value of thermistor. For characteristics, refer to (P1) above.</p> <p>② Check contact failure of connector (CN44) on the indoor controller board. Refer to "9-6. TEST POINT DIAGRAM". Turn the power on and check restart after inserting connector again.</p> <p>④ Operate in test run mode and check pipe &lt;condenser / evaporator&gt; temperature with outdoor controller circuit board. If pipe &lt;condenser / evaporator&gt; temperature is extremely low (in cooling mode) or high (in heating mode), refrigerant circuit may have defect.</p> <p>⑤ Operate in test run mode and check pipe &lt;condenser / evaporator&gt; temperature with outdoor control circuit board. If there is extreme difference with actual pipe &lt;condenser / evaporator&gt; temperature, replace indoor controller board. There is no abnormality if none of above comes within the unit. Turn the power off and on again to operate.</p> <p>( In case of checking pipe temperature with outdoor controller circuit board, be sure to connect A-control service tool (PAC-SK52ST). )</p>
E0 or E4	<p><b>Remote controller transmission error(E0)/signal receiving error(E4)</b></p> <p>① Abnormal if main or sub remote controller cannot receive any transmission normally from indoor unit of refrigerant address "0" for 3 minutes. (Check code : E0)</p> <p>② Abnormal if sub remote controller could not receive any signal for 2 minutes. (Check code: E0)</p> <p>① Abnormal if indoor controller board can not receive any data normally from remote controller board or from other indoor controller board for 3 minutes. (Check code: E4)</p> <p>② Indoor controller board cannot receive any signal from remote controller for 2 minutes. (Check code: E4)</p>	<p>① Contact failure at transmission wire of remote controller</p> <p>② All remote controllers are set as "sub" remote controller. In this case, E0 is displayed on remote controller, and E4 is displayed at LED (LED1, LED2) on the outdoor controller circuit board.</p> <p>③ Miswiring of remote controller</p> <p>④ Defective transmitting receiving circuit of remote controller</p> <p>⑤ Defective transmitting receiving circuit of indoor controller board of refrigerant addresses "0".</p> <p>⑥ Noise has entered into the transmission wire of remote controller.</p>	<p>① Check disconnection or looseness of indoor unit or transmission wire of remote controller.</p> <p>② Set one of the remote controllers "main" if there is no problem with the action above.</p> <p>③ Check wiring of remote controller.</p> <ul style="list-style-type: none"> <li>• Total wiring length: max. 500 m (Do not use cable × 3 or more.)</li> <li>• The number of connecting indoor units: max. 16 units</li> <li>• The number of connecting remote controller: max. 2 units</li> </ul> <p>When it is not the above-mentioned problem of ①-③</p> <p>④ Diagnose remote controllers.</p> <p>a) When "RC OK" is displayed, Remote controllers have no problem. Turn the power off, and on again to check. If abnormality generates again, replace indoor controller board.</p> <p>b) When "RC NG" is displayed, Replace remote controller.</p> <p>c) When "RC E3" or "ERC 00-66" is displayed, noise may be causing abnormality.</p> <p>Note: If the unit is not normal after replacing indoor controller board in group control, indoor controller board of address "0" may be abnormal.</p>
E3 or E5	<p><b>Remote controller transmission error(E3)/signal receiving error(E5)</b></p> <p>① Abnormal if remote controller could not find blank of transmission path for 6 seconds and could not transmit. (Check code: E3)</p> <p>② Remote controller receives transmitted data at the same time and compares the received and transmitted data. Abnormal if these data are judged to be different 30 continuous times. (Check code: E3)</p> <p>① Abnormal if indoor controller board could not find blank of transmission path. (Check code: E5)</p> <p>② Indoor controller board receives transmitted data at the same time and compares the received and transmitted data. Abnormal if these data are judged to be different 30 continuous times. (Check code: E5)</p>	<p>① 2 remote controllers are set as "main." (In case of 2 remote controllers)</p> <p>② Remote controller is connected with 2 indoor units or more.</p> <p>③ Repetition of refrigerant address</p> <p>④ Defective transmitting receiving circuit of remote controller</p> <p>⑤ Defective transmitting receiving circuit of indoor controller board</p> <p>⑥ Noise has entered into transmission wire of remote controller.</p>	<p>① Set a remote controller to main, and the other to sub.</p> <p>② Remote controller is connected with only one indoor unit.</p> <p>③ The address changes to a separate setting.</p> <p>④-⑥ Diagnose remote controller.</p> <p>a) When "RC OK" is displayed, remote controllers have no problem. Turn the power off, and on again to check. When becoming abnormal again, replace indoor controller board.</p> <p>b) When "RC NG" is displayed, replace remote controller.</p> <p>c) When "RC E3" or "ERC 00-66" is displayed, noise may be causing abnormality.</p>



Check Code	Abnormal point and detection method	Cause	Countermeasure
E6	<p><b>Indoor/outdoor unit communication error (Signal receiving error)</b></p> <p>① Abnormal if indoor controller board cannot receive any signal normally for 6 minutes after turning the power on.</p> <p>② Abnormal if indoor controller board cannot receive any signal normally for 3 minutes.</p> <p>③ Consider the unit abnormal under the following condition: When 2 or more indoor units are connected to an outdoor unit, indoor controller board cannot receive a signal for 3 minutes from outdoor controller circuit board, a signal which allows outdoor controller circuit board to transmit signals.</p>	<p>① Contact failure, short circuit or, miswiring (converse wiring) of indoor/outdoor unit connecting wire</p> <p>② Defective transmitting receiving circuit of indoor controller board</p> <p>③ Defective transmitting receiving circuit of indoor controller board</p> <p>④ Noise has entered into indoor/outdoor unit connecting wire.</p>	<p>Note: Check LED display on the outdoor control circuit board. (Connect A-control service tool, PAC-SK52ST.) Refer to outdoor unit service manual.</p> <p>① Check disconnection or looseness of indoor/outdoor unit connecting wire of indoor unit or outdoor unit. Check all the units in case of twin triple indoor unit system.</p> <p>②-④ Turn the power off, and on again to check. If abnormality generates again, replace indoor controller board or outdoor controller circuit board.</p> <p>Note: Other indoor controller board may have defect in the case of twin triple indoor unit system.</p>
E7	<p><b>Indoor/outdoor unit communication error (Transmitting error)</b></p> <p>Abnormal if "1" receiving is detected 30 times continuously though indoor controller board has transmitted "0".</p>	<p>① Defective transmitting receiving circuit of indoor controller board</p> <p>② Noise has entered into power supply.</p> <p>③ Noise has entered into outdoor control wire.</p>	<p>①-③ Turn the power off, and on again to check. If abnormality generates again, replace indoor controller board.</p>
Fb	<p><b>Indoor controller board</b></p> <p>Abnormal if data cannot be read normally from the nonvolatile memory of the indoor controller board.</p>	<p>① Defective indoor controller board</p>	<p>① Replace indoor controller board.</p>
E1 or E2	<p><b>Remote controller control board</b></p> <p>① Abnormal if data cannot be read normally from the nonvolatile memory of the remote controller control board. (Check code: E1)</p> <p>② Abnormal if the clock function of remote controller cannot be operated normally. (Check code: E2)</p>	<p>① Defective remote controller</p>	<p>① Replace remote controller.</p>
PA	<p><b>Forced compressor stop (due to water leakage abnormality)</b></p> <p>① When the intake temperature subtracted with liquid pipe temperature is less than <math>-10^{\circ}\text{C}</math>, drain sensor is detected whether it is soaked in the water or not at the interval of 90 seconds. (Drain pump will start operating when the drain sensor is detected to be soaked in the water.)</p> <p>② The unit has a water leakage abnormality when the following conditions, a and b, are satisfied while the above-mentioned detection is performed.</p> <p>a) The drain sensor is detected to be soaked in the water 10 times in a row.</p> <p>b) The intake temperature subtracted with liquid pipe temperature is detected to be less than <math>-10^{\circ}\text{C}</math> for a total of 30 minutes. (When the drain sensor is detected to be NOT soaked in the water, the detection record of a and b will be cleared.)</p> <p>③ The drain sensor detection is performed in operations other than cooling. (When the unit stops operating, during heating or fan operation, when the unit stops because of some abnormality)</p> <p>Note: Once the water leakage abnormality is detected, abnormality state will not be released until the main power is reset.</p>	<p>① Drain pump trouble</p> <p>② Drain defective · Drain pump clogging · Drain pipe clogging</p> <p>③ Open circuit of drain sensor side heater</p> <p>④ Contact failure of drain sensor connector</p> <p>⑤ Dew condensation on drain sensor · Drain water descends along lead wire. · Drain water is waving due to filter clogging.</p> <p>⑥ Extension piping connection difference at twin, triple or quadruple system</p> <p>⑦ Miswiring of indoor/ outdoor connecting at twin, triple or quadruple system</p> <p>⑧ Room temperature thermistor / liquid pipe temperature thermistor detection is defective.</p>	<p>① Check the drain pump.</p> <p>② Please confirm whether water can be drained.</p> <p>③ Confirm the resistance of the drain sensor.</p> <p>④ Check the connector contact failure.</p> <p>⑤ Check the drain sensor leadwire mounted. Check the filter clogging</p> <p>⑥ Check the piping connection.</p> <p>⑦ Check the indoor/ outdoor connecting wires.</p> <p>⑧ Check the room temperature display of remote controller. Check the indoor liquid pipe temperature display of outdoor controller board.</p>

### 9-3. TROUBLESHOOTING BY INFERIOR PHENOMENA

Note: Refer to the manual of outdoor unit for the detail of remote controller.

Phenomena	Cause	Countermeasure
<p><b>(1)LED2 on indoor controller board is off.</b></p>	<ul style="list-style-type: none"> <li>• When LED1 on indoor controller board is also off.</li> <li>① Power supply of rated voltage is not supplied to outdoor unit.</li> <li>② Defective outdoor controller circuit board</li> <li>③ Power supply of 220–240 V is not supplied to indoor unit</li> <li>④ Defective indoor power board</li> <li>⑤ Defective indoor controller board</li> </ul> <p><b>(For the separate indoor/outdoor unit power supply system)</b></p> <ul style="list-style-type: none"> <li>① Power supply of 220–240 V AC is not supplied to indoor unit.</li> <li>② The connectors of the optional replacement kit are not used.</li> <li>③ Defective indoor controller board</li> <li>④ Defective indoor power board</li> </ul>	<ul style="list-style-type: none"> <li>① Check the voltage of outdoor power supply terminal block (L, N) or (L3, N). <ul style="list-style-type: none"> <li>• When 220–240 V AC is not detected. Check the power wiring to outdoor unit and the breaker.</li> <li>• When 220–240 V AC is detected. —Check ② (below).</li> </ul> </li> <li>② Check the voltage between outdoor terminal block S1 and S2. <ul style="list-style-type: none"> <li>• When 220–240 V AC is not detected. Check the fuse on outdoor controller circuit board.</li> <li>• When 220–240 V AC is detected. Check the wiring connection. —Check ③ (below).</li> </ul> </li> <li>③ Check the voltage between indoor terminal block S1 and S2. <ul style="list-style-type: none"> <li>• When 220–240 V AC is not detected. Check indoor/outdoor unit connecting wire for mis-wiring.</li> <li>• When 220–240 V AC is detected. —Check ④ (below).</li> </ul> </li> <li>④ Check voltage output from CN2S on indoor power board (13.1 V DC). Refer to "9-6-1. Power board". <ul style="list-style-type: none"> <li>• When no voltage is output. Check the wiring connection.</li> <li>• When output voltage is between 12.5 V DC and 13.7 V DC. —Check ⑤ (below).</li> </ul> </li> <li>⑤ Check the wiring connection between indoor controller board and indoor power board. Check the fuse on indoor controller board. If no problems are found, indoor controller board is defective.</li> </ul> <p><b>(For the separate indoor/outdoor unit power supply system)</b></p> <ul style="list-style-type: none"> <li>① Check the voltage of indoor power supply terminal block (L,N). <ul style="list-style-type: none"> <li>• When 220–240 V AC is not detected. Check the power supply wiring.</li> <li>• When 220–240 V AC is detected. —Check ② (below).</li> </ul> </li> <li>② Check that there is no problem in the method of connecting the connectors. <ul style="list-style-type: none"> <li>• When there are problems in the method of connecting the connectors. Connect the connector correctly referring to installation manual of an optional kit.</li> <li>• When there is no problem in the method of connecting the connectors. —Check ③ (below).</li> </ul> </li> <li>③ Check voltage output from CNDK on indoor controller board. <ul style="list-style-type: none"> <li>• When 220–240 V AC is not detected. Check the fuse on indoor controller board. Check the wiring connection between indoor power supply terminal block and CND on indoor controller board.</li> <li>• When 220–240 V AC is detected. —Check ④ (below).</li> </ul> </li> <li>④ Check voltage output from CN2S on indoor power board. <ul style="list-style-type: none"> <li>• When no voltage output. Check the wiring connection between CNDK on indoor controller board and CNSK on indoor power board. If no problem are found, indoor power board is defective.</li> <li>• When 12.5–13.7 V DC is detected. Check the wiring connection between CN2S on indoor power board and CN2D on indoor power board. If no problem is found, indoor controller board is defective.</li> </ul> </li> </ul>
	<ul style="list-style-type: none"> <li>• When LED1 on indoor controller board is lit.</li> <li>① Mis-setting of refrigerant address for outdoor unit (There is no unit corresponding to refrigerant address "0".)</li> </ul>	<ul style="list-style-type: none"> <li>① Reconfirm the setting of refrigerant address for outdoor unit Set the refrigerant address to "0". (For grouping control system under which 2 or more outdoor units are connected, set one of the units to "0".) Set refrigerant address using SW1 (3-6) on outdoor controller circuit board.</li> </ul>

Note: Refer to the outdoor unit's service manual for the detail of remote controller.

Phenomena	Cause	Countermeasure
(2)LED2 on indoor controller board is blinking.	<ul style="list-style-type: none"> <li>• When LED1 on indoor controller board is also blinking. Connection failure of indoor/outdoor unit connecting wire</li> <li>• When LED1 is lit.</li> </ul> <p>① Mis-wiring of remote controller wires Under twin triple indoor unit system, 2 or more indoor units are wired together.</p> <p>② Refrigerant address for outdoor unit is wrong or not set. Under grouping control system, there are some units whose refrigerant address is 0.</p> <p>③ Short-cut of remote controller wires ④ Defective remote controller</p>	<p>Check indoor/outdoor unit connecting wire for connection failure.</p> <p>① Check the connection of remote controller wires in case of twin triple indoor unit system. When 2 or more indoor units are wired in one refrigerant system, connect remote controller wires to one of those units.</p> <p>② Check the setting of refrigerant address in case of grouping control system. If there are some units whose refrigerant address is 0 in one group, set one of the units to 0 using SW1 (3-6) on outdoor controller circuit board.</p> <p>③④ Remove remote controller wires and check LED2 on indoor controller board.</p> <ul style="list-style-type: none"> <li>• When LED2 is blinking, check the short-cut of remote controller wires.</li> <li>• When LED2 is lit, connect remote controller wires again and: if LED2 is blinking, remote controller is defective; if LED2 is lit, connection failure of remote controller terminal block etc. has returned to normal.</li> </ul>
(3)Upward/downward vane performance failure	<p>① The vane is not downward during defrosting and heat preparation and when the thermostat is OFF in HEAT mode. (Working of COOL protection function)</p> <p>② Vane motor does not rotate.</p> <ul style="list-style-type: none"> <li>• Defective vane motor</li> <li>• Breaking of wire or connection failure of connector</li> <li>• Up/down vane setting is "No vanes".</li> </ul> <p>③ Upward/downward vane does not work.</p> <ul style="list-style-type: none"> <li>• The vane is set to fixed position.</li> </ul>	<p>① Normal operation (The vane is set to horizontal regardless of remote control.)</p> <p>② Check ② (left).</p> <ul style="list-style-type: none"> <li>• Check the vane motor. (Refer to "How to check the parts".)</li> <li>• Check for breaking of wire or connection failure of connector.</li> <li>• Check "Up/down vane setting". (Unit function selection by remote controller).</li> </ul> <p>③ Normal operation (Each connector on vane motor side is disconnected.)</p>
(4)Receiver for wireless remote controller	<p>① Weak batteries of wireless remote controller</p> <p>② Contact failure of connector (CNB) on wireless remote controller board. (Insert failure)</p> <p>③ Contact failure of connector (CN90) on indoor controller board. (Insert failure)</p> <p>④ Contact failure of connector between wireless remote controller board and indoor controller board.</p>	<p>① Replace batteries of wireless remote controller.</p> <p>②-④</p> <p>Check contact failure of each connector. If no problems are found of connector, replace indoor controller board. When the same trouble occurs even if indoor controller board is replaced, replace wireless remote controller board.</p>

#### 9-4. WHEN WIRED REMOTE CONTROLLER OR INDOOR UNIT MICROPROCESSOR FAILS

1. When the wired remote control or the indoor unit microprocessor has failed, but all other components work properly, if you set the switch (SWE) on the indoor controller board ON, the indoor unit will begin emergency operation.  
When emergency operation is activated, the indoor unit operates as follows:
  - Indoor fan is running at high speed.
2. When you activate emergency operation of the cooling or heating, you have to set the switch (SWE) on the indoor controller board and activate emergency operation of the outdoor unit.  
For details on how to activate emergency operation of the outdoor unit, refer to the outdoor unit wiring diagram.
3. Before you activate emergency operation, check the following points:
  - (1) Emergency operation cannot be activated when:
    - the outdoor unit malfunctions.
    - the indoor fan malfunctions.
    - it has detected the malfunction of drain pump during self-diagnosing. (Check code: P5)
  - (2) Emergency operation becomes continuous only by switching the power source on/off.  
ON/OFF on the remote control or temperature control, etc. does not function.
  - (3) Avoid operating for a long time when the outdoor unit begins defrosting while emergency operation of the heating is activated because it will start to blow cold air.
  - (4) Emergency cooling should be limited to 10 hours maximum (The indoor unit heat exchanger may freeze).
  - (5) After emergency operation has been deactivated set the switches, etc. to their original positions.
  - (6) Movement of the vanes does not work in emergency operation, therefore you have to slowly set them manually to the appropriate position.

## 9-5. HOW TO CHECK THE PARTS

### PCA-RP71HAQ      PCA-RP125HAQ

### PCA-RP71HAQ-ER

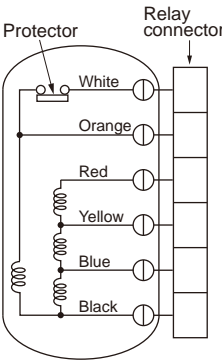
Parts name	Check points																						
Room temperature thermistor (TH1)	Disconnect the connector then measure the resistance with a tester. (At the ambient temperature 10 to 30°C)																						
Pipe temperature thermistor/liquid (TH2)	<table border="1"> <thead> <tr> <th>Normal</th> <th>Abnormal</th> </tr> </thead> <tbody> <tr> <td>4.3 to 9.6kΩ</td> <td>Open or short</td> </tr> </tbody> </table> Refer to the <Thermistor Characteristic Graph> below.	Normal	Abnormal	4.3 to 9.6kΩ	Open or short																		
Normal		Abnormal																					
4.3 to 9.6kΩ	Open or short																						
Condenser/evaporator temperature thermistor (TH5)																							
Fan motor(MF) 	Measure the resistance between the terminals with a tester. (Winding temperature 20°C) <table border="1"> <thead> <tr> <th rowspan="2">Connector</th> <th colspan="2">Normal</th> <th rowspan="2">Abnormal</th> </tr> <tr> <th>PCA-RP71</th> <th>PCA-RP125</th> </tr> </thead> <tbody> <tr> <td>White-Black</td> <td>140.5Ω</td> <td>75.6Ω</td> <td rowspan="5">Open or short</td> </tr> <tr> <td>Black-Blue</td> <td>15.4Ω</td> <td>36.7Ω</td> </tr> <tr> <td>Blue-Yellow</td> <td>28.5Ω</td> <td>23.6Ω</td> </tr> <tr> <td>Yellow-Red</td> <td>80.4Ω</td> <td>47.8Ω</td> </tr> <tr> <td></td> <td></td> <td></td> </tr> </tbody> </table> Protector OPEN : 135±5°C CLOSE : 95±15°C	Connector	Normal		Abnormal	PCA-RP71	PCA-RP125	White-Black	140.5Ω	75.6Ω	Open or short	Black-Blue	15.4Ω	36.7Ω	Blue-Yellow	28.5Ω	23.6Ω	Yellow-Red	80.4Ω	47.8Ω			
Connector	Normal		Abnormal																				
	PCA-RP71	PCA-RP125																					
White-Black	140.5Ω	75.6Ω	Open or short																				
Black-Blue	15.4Ω	36.7Ω																					
Blue-Yellow	28.5Ω	23.6Ω																					
Yellow-Red	80.4Ω	47.8Ω																					

#### <Thermistor Characteristic Graph>

Thermistor for lower temperature

Room temperature thermistor(TH1)  
 Pipe temperature thermistor/ liquid (TH2)  
 Condenser/evaporator temperature thermistor(TH5)

Thermistor  $R_0=15\text{ k}\Omega \pm 3\%$   
 Fixed number of  $B=3480\text{ k}\Omega \pm 2\%$

$$R_t = 15 \exp \left\{ 3480 \left( \frac{1}{273+t} - \frac{1}{273} \right) \right\}$$

0°C	15 kΩ
10°C	9.6 kΩ
20°C	6.3 kΩ
25°C	5.4 kΩ
30°C	4.3 kΩ
40°C	3.0 kΩ

< Thermistor for lower temperature >

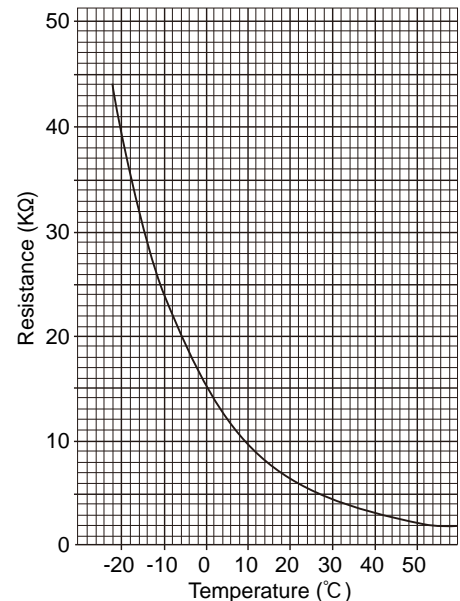

## 9-6. TEST POINT DIAGRAM

### 9-6-1. Power board

PCA-RP71HAQ

PCA-RP125HAQ

PCA-RP71HAQ-ER

CNSK  
Connect to the indoor controller board  
(CNDK)  
Between ① to ③ 220–240 V AC

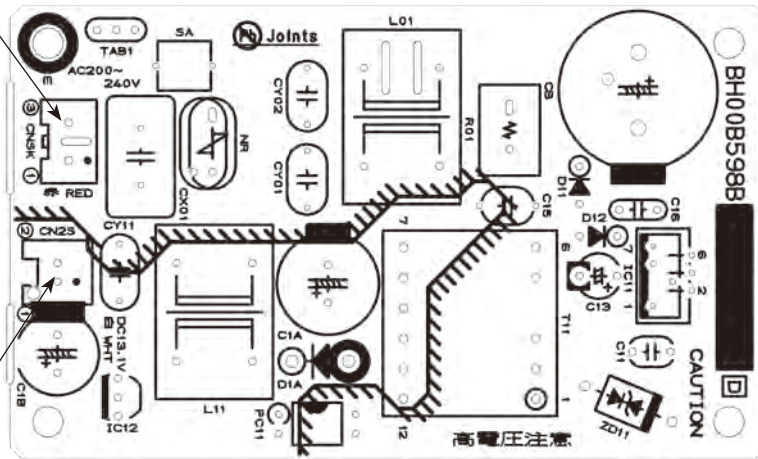

CN2S  
Connect to the indoor controller board (CN2D)  
Between ① to ③ 12.6–13.7 V DC (Pin① (+))



**9-6-2. Indoor controller board**  
**PCA-RP71HAQ      PCA-RP125HAQ**  
**PCA-RP71HAQ-ER**

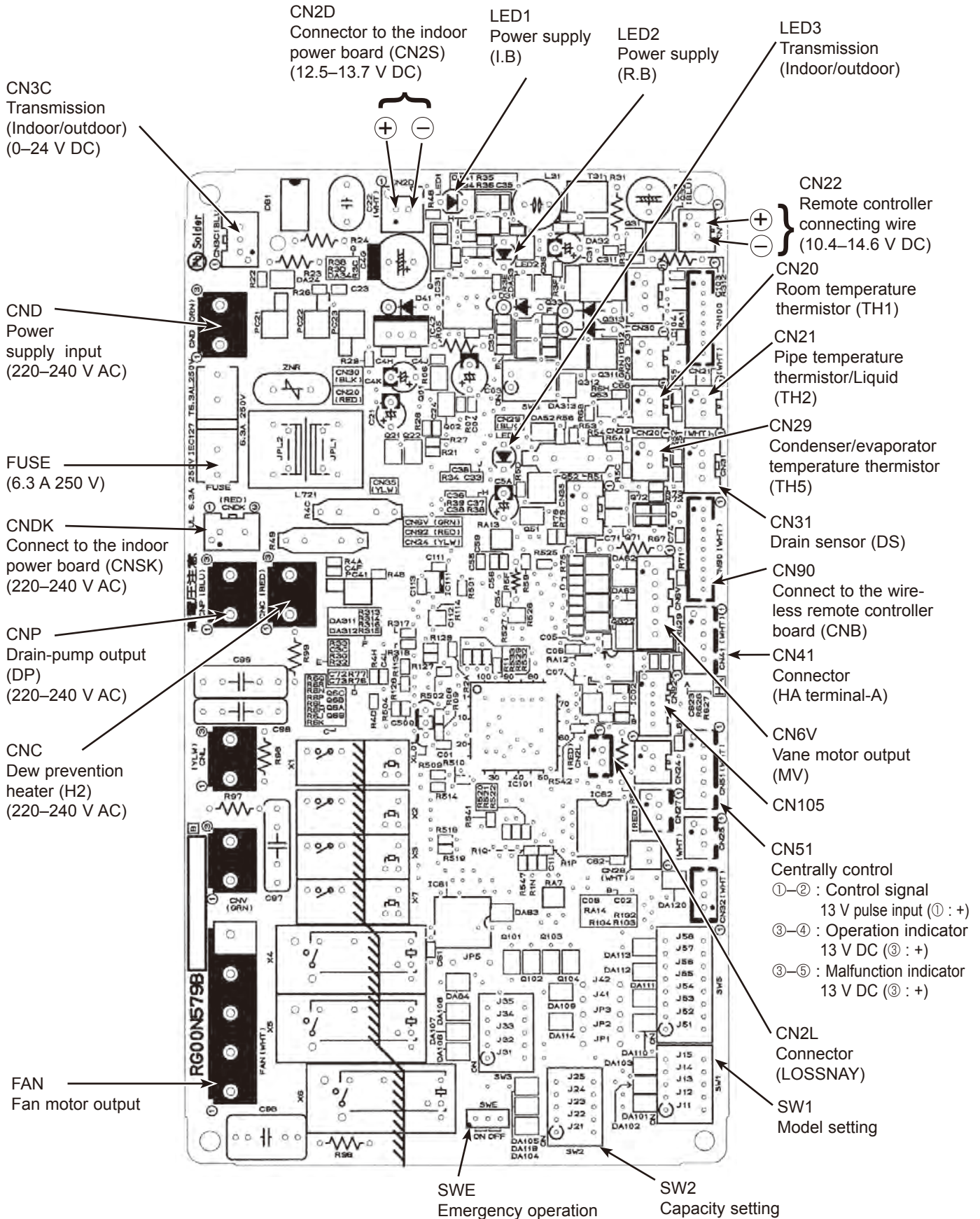

## 9-7. FUNCTIONS OF DIP SWITCH AND JUMPER WIRE

Each function is controlled by the dip switch and the jumper wire on controller board.

SW1 and SW2 are equipped only for service parts.

Model setting and capacity setting are preset in the nonvolatile memory of the controller board of the unit.

The black square (■) indicates a switch position.

(Marks in the table below) Jumper wire (○ : Short × : Open)

Jumper wire	Functions	Setting by the DIP switch and jumper wire	Remarks																														
SW1	Model settings	<table border="1"> <tr> <td>MODEL</td> <td>Service board</td> </tr> <tr> <td>PCA-RP・HAQ</td> <td> <table border="1"> <tr> <td>1</td> <td>2</td> <td>3</td> <td>4</td> <td>5</td> <td>ON</td> </tr> <tr> <td>■</td> <td>■</td> <td>■</td> <td>■</td> <td>■</td> <td>OFF</td> </tr> </table> </td> </tr> </table>	MODEL	Service board	PCA-RP・HAQ	<table border="1"> <tr> <td>1</td> <td>2</td> <td>3</td> <td>4</td> <td>5</td> <td>ON</td> </tr> <tr> <td>■</td> <td>■</td> <td>■</td> <td>■</td> <td>■</td> <td>OFF</td> </tr> </table>	1	2	3	4	5	ON	■	■	■	■	■	OFF															
MODEL	Service board																																
PCA-RP・HAQ	<table border="1"> <tr> <td>1</td> <td>2</td> <td>3</td> <td>4</td> <td>5</td> <td>ON</td> </tr> <tr> <td>■</td> <td>■</td> <td>■</td> <td>■</td> <td>■</td> <td>OFF</td> </tr> </table>	1	2	3	4	5	ON	■	■	■	■	■	OFF																				
1	2	3	4	5	ON																												
■	■	■	■	■	OFF																												
SW2	Capacity settings	<table border="1"> <tr> <td>MODEL</td> <td>Service board</td> </tr> <tr> <td>PCA-RP71HAQ</td> <td> <table border="1"> <tr> <td>1</td> <td>2</td> <td>3</td> <td>4</td> <td>5</td> <td>ON</td> </tr> <tr> <td>■</td> <td>■</td> <td>■</td> <td>■</td> <td>■</td> <td>OFF</td> </tr> </table> </td> </tr> <tr> <td>PCA-RP125HAQ</td> <td> <table border="1"> <tr> <td>1</td> <td>2</td> <td>3</td> <td>4</td> <td>5</td> <td>ON</td> </tr> <tr> <td>■</td> <td>■</td> <td>■</td> <td>■</td> <td>■</td> <td>OFF</td> </tr> </table> </td> </tr> </table>	MODEL	Service board	PCA-RP71HAQ	<table border="1"> <tr> <td>1</td> <td>2</td> <td>3</td> <td>4</td> <td>5</td> <td>ON</td> </tr> <tr> <td>■</td> <td>■</td> <td>■</td> <td>■</td> <td>■</td> <td>OFF</td> </tr> </table>	1	2	3	4	5	ON	■	■	■	■	■	OFF	PCA-RP125HAQ	<table border="1"> <tr> <td>1</td> <td>2</td> <td>3</td> <td>4</td> <td>5</td> <td>ON</td> </tr> <tr> <td>■</td> <td>■</td> <td>■</td> <td>■</td> <td>■</td> <td>OFF</td> </tr> </table>	1	2	3	4	5	ON	■	■	■	■	■	OFF	
MODEL	Service board																																
PCA-RP71HAQ	<table border="1"> <tr> <td>1</td> <td>2</td> <td>3</td> <td>4</td> <td>5</td> <td>ON</td> </tr> <tr> <td>■</td> <td>■</td> <td>■</td> <td>■</td> <td>■</td> <td>OFF</td> </tr> </table>	1	2	3	4	5	ON	■	■	■	■	■	OFF																				
1	2	3	4	5	ON																												
■	■	■	■	■	OFF																												
PCA-RP125HAQ	<table border="1"> <tr> <td>1</td> <td>2</td> <td>3</td> <td>4</td> <td>5</td> <td>ON</td> </tr> <tr> <td>■</td> <td>■</td> <td>■</td> <td>■</td> <td>■</td> <td>OFF</td> </tr> </table>	1	2	3	4	5	ON	■	■	■	■	■	OFF																				
1	2	3	4	5	ON																												
■	■	■	■	■	OFF																												
J41 J42	Pair number setting with wireless remote controller	<table border="1"> <tr> <td>Wireless remote controller setting</td> <td colspan="2">Control PCB setting</td> </tr> <tr> <td></td> <td>J41</td> <td>J42</td> </tr> <tr> <td>0</td> <td>○</td> <td>○</td> </tr> <tr> <td>1</td> <td>×</td> <td>○</td> </tr> <tr> <td>2</td> <td>○</td> <td>×</td> </tr> <tr> <td>3 ~ 9</td> <td>×</td> <td>×</td> </tr> </table>	Wireless remote controller setting	Control PCB setting			J41	J42	0	○	○	1	×	○	2	○	×	3 ~ 9	×	×	<p>&lt;Initial setting&gt;            Wireless remote controller: 0            Control PCB: ○ (for both J41 and J42)            Four pair number settings are supported.            The pair number settings of the wireless remote controller and indoor control PCB (J41/J42) are given in the table on the left.            ('×' in the table indicates the jumper line is disconnected.)</p>												
Wireless remote controller setting	Control PCB setting																																
	J41	J42																															
0	○	○																															
1	×	○																															
2	○	×																															
3 ~ 9	×	×																															
JP1	Unit type setting	<table border="1"> <tr> <td>Model</td> <td>JP1</td> </tr> <tr> <td>Without TH5</td> <td>○</td> </tr> <tr> <td>With TH5</td> <td>×</td> </tr> </table>	Model	JP1	Without TH5	○	With TH5	×	There is no jumper (JP1) because these models have the cond./eva. temperature thermistor (TH5).																								
Model	JP1																																
Without TH5	○																																
With TH5	×																																
JP3	Indoor controller board type setting	<table border="1"> <tr> <td>Indoor controller board type</td> <td>JP3</td> </tr> <tr> <td>For product</td> <td>×</td> </tr> <tr> <td>Service parts</td> <td>○</td> </tr> </table>	Indoor controller board type	JP3	For product	×	Service parts	○																									
Indoor controller board type	JP3																																
For product	×																																
Service parts	○																																

10-1. ROTATION FUNCTION (AND BACK-UP FUNCTION, 2ND STAGE CUT-IN FUNCTION)

10-1-1. Operation

(1) Rotation function (and Back-up function)

• Outline of functions

- Main and sub unit operate alternately according to the interval of rotation setting.
- Main and sub unit should be set by refrigerant address. (Outdoor DIP switch setting)
- Refrigerant address "00" → Main unit
- Refrigerant address "01" → Sub unit
- When an error occurs to one unit, another unit will start operation. (Back-up function)

• System constraint

- This function is available only by the grouping control system (INDOOR UNIT : OUTDOOR UNIT=1:1) of 2 refrigerant groups. (Refer to Fig. 1)
- Main indoor unit should be connected for wired remote controller and the transmission line (TB5) for main and sub unit should also be connected. (Refer to Fig. 1)
- (This function cannot be set by wireless remote controller.)
- Set refrigerant address of each unit. (DIP switch on the outdoor unit→Refrigerant address 00/01)

Operation pattern

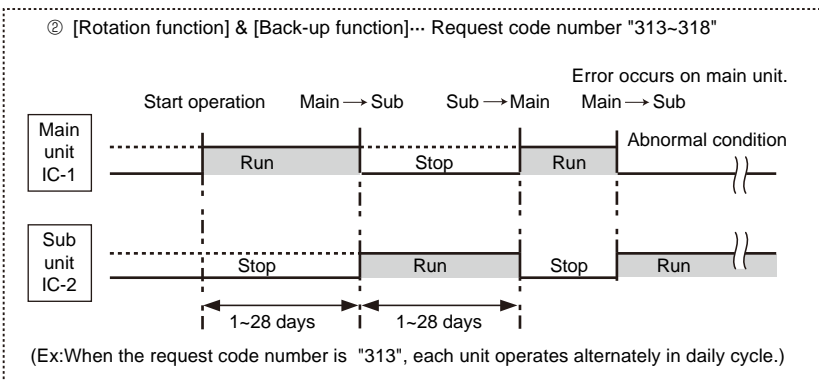
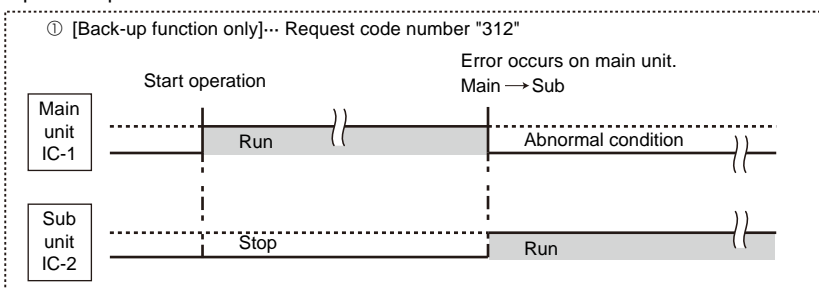

Note:

- When the unit is restarted to operate after turning off the power or OFF operation, the unit which was operating will start operation.
- To operate the main unit, refer to "10-1-2. How to set rotation function (Back-up function, 2nd stage cut-in function)" and set the request code No. which is not the same as the current one, then set again the former request code No.

(2) 2nd stage cut-in function

Outline of functions

- Number of operating units is determined according to the room temperature and set point.
- When room temperature becomes higher than set point, standby unit starts. (2 units operation)
- When room temperature falls below set point -4°C, standby unit stops. (1 unit operation)

System constraint

- This function is available only in rotation operation and back-up function in cooling mode.

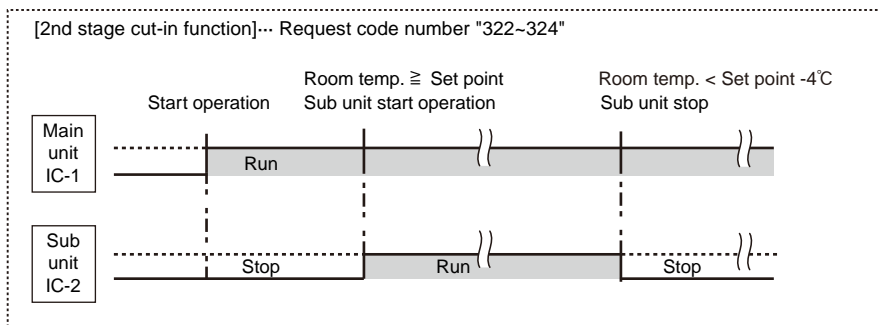
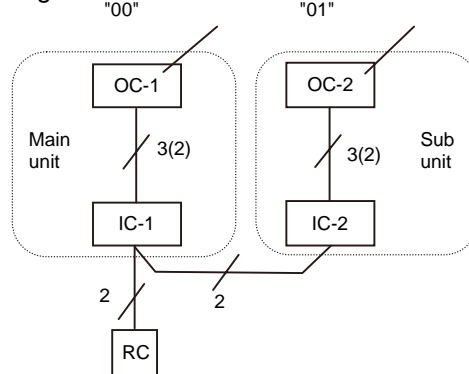

Fig. 1 Refrigerant address "00" Refrigerant address "01"



OC : Outdoor unit  
 IC : Indoor unit  
 RC : Wired remote controller

## 10-1-2. How to set rotation function (Back-up function, 2nd stage cut-in function)

You can set these functions by wired remote controller. (Maintenance monitor)

### NOTICE

Both main and sub unit should be set in same setting.  
Every time replacing indoor controller board for servicing, the function should be set again.

#### (1) Request Code List

##### Rotation setting

Setting No. (Request code)	Setting contents	Initial setting
No.1 (310)	Monitoring the request code of current setting	
No.2 (311)	Rotation and Back-up OFF (Normal group control operation)	☉
No.3 (312)	Back-up function only	
No.4 (313)	Rotation ON (Alternating interval = 1day) and back up function	
No.5 (314)	Rotation ON (Alternating interval = 3day) and back up function	
No.6 (315)	Rotation ON (Alternating interval = 5day) and back up function	
No.7 (316)	Rotation ON (Alternating interval = 7day) and back up function	
No.8 (317)	Rotation ON (Alternating interval = 14day) and back up function	
No.9 (318)	Rotation ON (Alternating interval = 28day) and back up function	

##### 2nd stage cut-in setting

Setting No. (Request code)	Setting contents	Initial setting
No.1 (320)	Monitoring the request code of current setting	
No.2 (321)	Cut-in function OFF	☉
No.3 (322)	Cut-in Function ON(Set point = Set temp.+ 4°C(7.2°F))	
No.4 (323)	Cut-in Function ON(Set point = Set temp.+ 6°C(10.8°F))	
No.5 (324)	Cut-in Function ON(Set point = Set temp.+ 8°C(14.4°F))	

## (2) Setting method of each function by wired remote controller

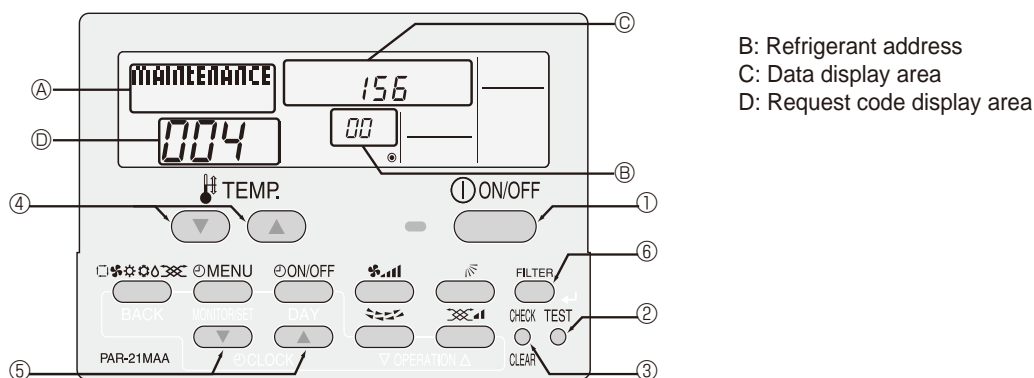

B: Refrigerant address  
C: Data display area  
D: Request code display area

1. Stop operation(①).
2. Press the **TEST** button (②) for 3 seconds so that [Maintenance mode] appears on the screen (A).  
After a while, [00] appears in the refrigerant address number display area.(at B )
3. Press the **CHECK** button (③) for 3 seconds to switch to [Maintenance monitor].  
Note) It is not possible to switch to [Maintenance monitor] during data request in maintenance mode (i.e., while "----" is blinking) since no buttons are operative.

[----] appears on the screen (C) when [Maintenance monitor] is activated.  
(The display (D) now allows you to set a request code No.)

4. Press the [TEMP ( **▽** and **△** )] buttons (④) to select the desired refrigerant address.

[ScreenB]

5. Press the [CLOCK ( **▽** and **△** )] buttons (⑤) to set the desired request code No. ("311~318", "321~324")
6. Press the **FILTER** button (⑥) to perform function setting.

If above setting operations are done correctly, "Request code number will appear in data display area.(C)  
[Example: When the "311" of "Request code number" is set, [311] appears on the screen.(C)]

### [Reference]

You can check current "request code number" setting by setting the "request code number" ("310" or "320") and pressing the **FILTER** button.(⑥)

[Example: When the current setting is "Setting No.2(Request code 311)", [311] appears on the screen.(C)]

7. To return to normal mode, press the **ON/OFF** button (①).

**(3) Setting method of each function by wired remote controller**

**■ PAR-30MAA/PAR-31MAA**

Stop operation (⏻)



Select "Service" from the Main menu, and press the (✓) button.



Select "Check" with the [F1] or [F2] button, and press the (✓) button.



Select "Request code" with the [F1] or [F2] button, and press the (✓) button.

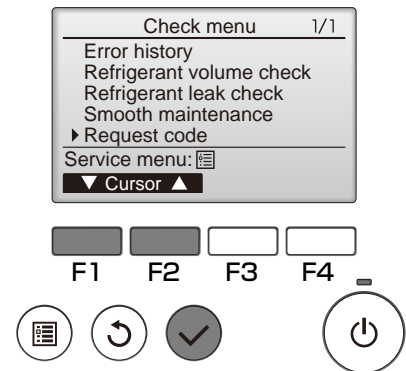

Set the Refrigerant address and Request code.

Select the item to be changed with the [F1] or [F2] button.

Select the required setting with the [F3] or [F4] button.

Select the required code No. (311–318, 321–324) with the [F3] or [F4] button.

- <Ref.address>setting [ 0 ] – [ 15 ]
- <Request code>setting

Press the (✓) button, Data will be collected and displayed.

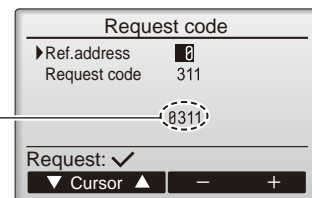
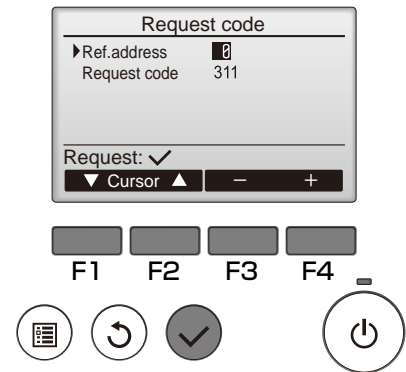

Request code: 311  
Rotation and Back-up OFF: 0311

#### (4) Rotation and back up operation

##### PAR-30MAA/PAR-31MAA

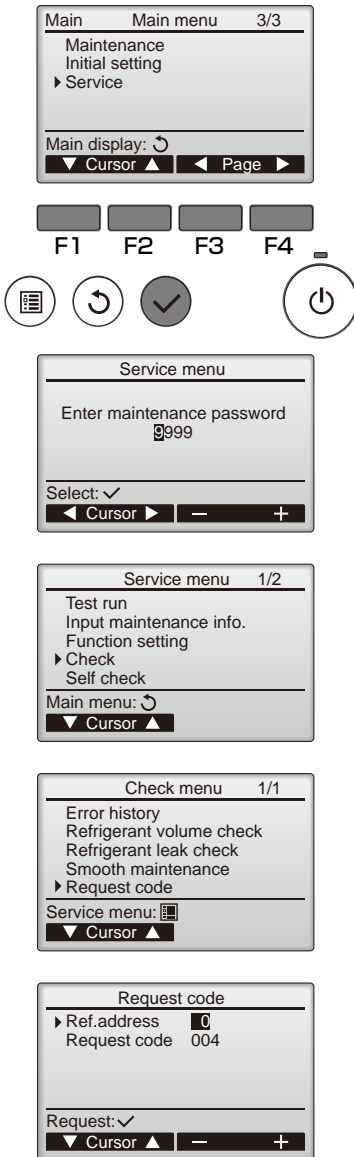

- ① Press the button.
- ② Select "Service" with the [Cursor] buttons ( and ) or the [Page] buttons ( and ), and press the button.
- ③ Enter the current maintenance password (4 numerical digits).
  - Move cursor to the digit you want to change with the or button.
  - Set each number (0 through 9) with the or button. (Note: The initial maintenance password is "9999".)
- ④ Then, press the button.
- ⑤ Select "Check" with the or button, and press the button.
- ⑥ Select "Request code" with the or button, and press the button.
- ⑦ Set the Refrigerant address and Request code.
  - Select the item to be changed with the or button.
  - Select the required setting with the or button.
- ⑧ Press the or button to set the Refrigerant address "0".
- ⑨ Press the or button to set the desired request code No.
  - Rotation & Back up operation: Enter one request code from 311 to 318.
  - 2nd stage cut-in operation: Enter one request code from 321 to 324.
- ⑩ Press the button. Data will be collected and displayed.
- ⑪ Press the or button to set the Refrigerant address "1". Set above ⑨-⑩.
- ⑫ To return to the Main menu, press the button.

##### PAR-21MAA

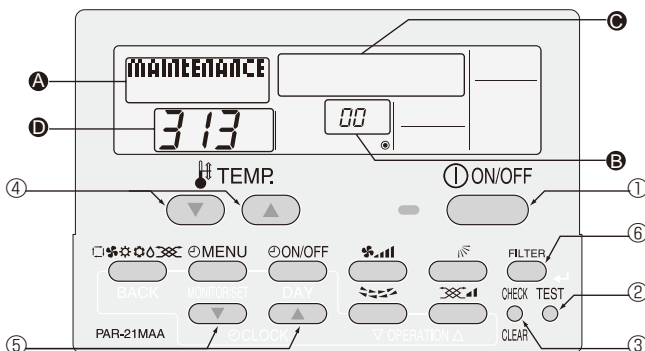

- Ⓑ Refrigerant address
- Ⓒ Data display area
- Ⓓ Request code display area

- ① To stop air conditioner, press the button.
- ② Press the button for 3 seconds so that "Maintenance mode" appears on the screen (at Ⓐ). "00" (Refrigerant address) appears on the screen in a few minutes (at Ⓑ).
- ③ Press the button for 3 seconds to switch to [Maintenance monitor]. "----" appears on the screen (at Ⓓ) when [Maintenance monitor] is activated.
- ④ Press the [CLOCK] buttons ( and ) to set the desired request code No.
  - Rotation & Back up operation: Enter one request code from 311 to 318.
  - 2nd stage cut-in operation: Enter one request code from 321 to 324.
- ⑤ Press the button to perform data request. (The requested data will be displayed at Ⓒ in the same way as in maintenance mode.)
- ⑥ Press the [TEMP] buttons ( and ) to set the Refrigerant address 01. "01" (Refrigerant address) appears on the screen in a few minutes (at Ⓑ). Set above ③-⑤.
- ⑦ To return to normal mode, press the button.

**PCA-RP71HAQ  
PCA-RP71HAQ-ER**

**PCA-RP125HAQ**

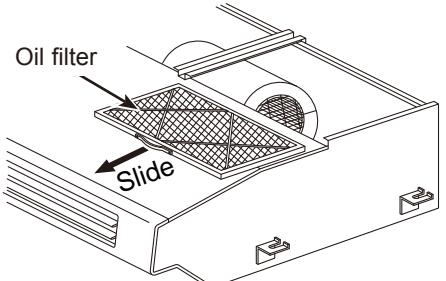
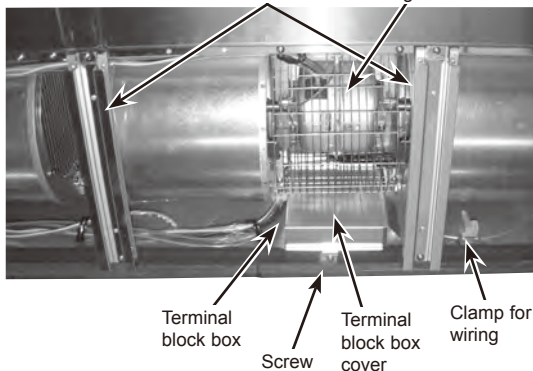
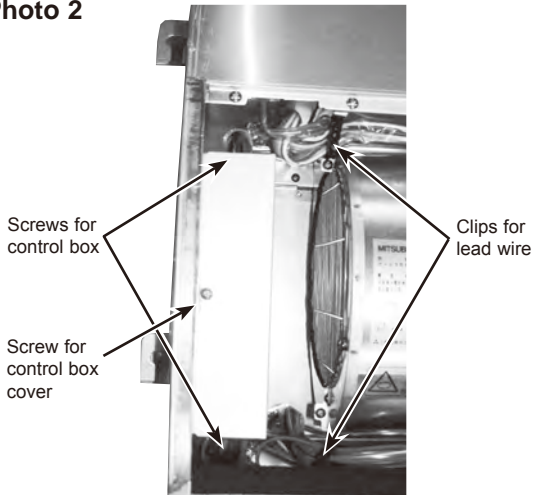
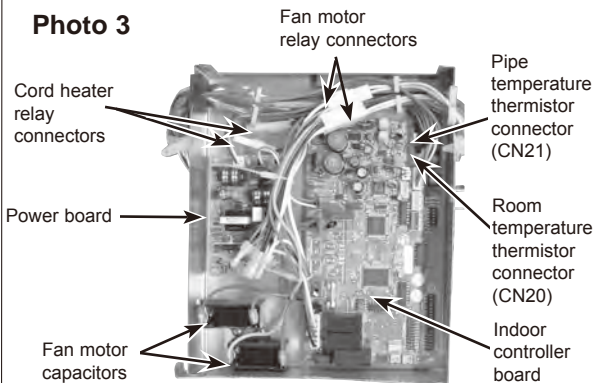
OPERATING PROCEDURE	PHOTOS & ILLUSTRATIONS
<p><b>1. Removing the oil filter</b>                      (1) Slide the oil filter towards you to remove. (See Figure 1)</p>	<p><b>Figure 1</b></p> 
<p><b>2. Removing the terminal block box cover</b>                      (1) Remove the oil filter. (See Figure 1)                      (2) Remove a screw for terminal block box cover, and remove the terminal block box cover. (See Photo 1)</p>	<p><b>Photo 1</b></p> 
<p><b>3. Removing the control box</b>                      (1) Remove the oil filter. (See Figure 1)                      (2) Loosen the screw for control box cover to remove the control box cover. (See Photo 2)                      (3) Remove the lead wire from the 2 clips.                      (4) Remove the 2 white cord heater relay connectors (1P × 2) and 2 fan motor relay connectors (6P × 2) in the control box.                      (5) Remove the 2 screws for control box to slide the control box downward.</p> <p>Electrical parts in the control box</p> <ul style="list-style-type: none"> <li>• Fan motor capacitor</li> <li>• Indoor controller board</li> <li>• Power board</li> </ul>	<p><b>Photo 2</b></p>  <p><b>Photo 3</b></p> 



## OPERATING PROCEDURE

### 4. Removing the fan motor

- (1) Remove the oil filter. (See Figure 1)
- (2) Remove the control box cover. (See Photo 2)
- (3) Remove the room temperature thermistor connector (CN20) on the indoor controller board. (See Photo 3)
- (4) Remove a filter rail that is the nearest to the control box. (See Photo 4)
- (5) Remove the fan guard. (See Photo 5)
- (6) Remove the room temperature thermistor together with the holder at the right side of the casing.

## PHOTOS & ILLUSTRATIONS

Photo 4

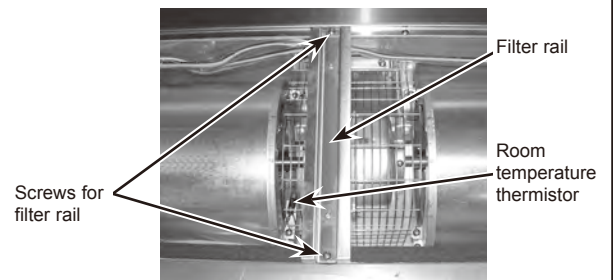
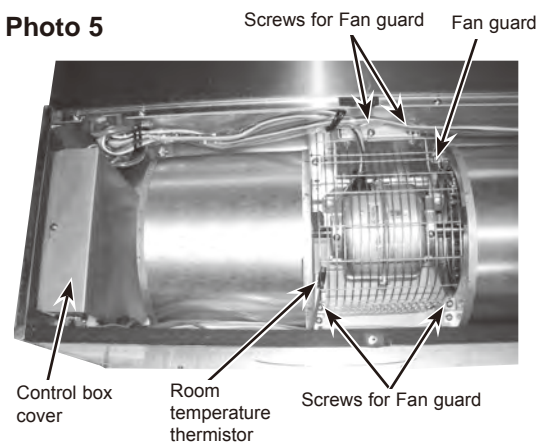

Photo 5



### 5. Removing the fan motor and the sirocco fan

- (1) Remove the oil filter. (See Figure 1)
- (2) Remove the control box cover. (See Photo 2.)
- (3) Remove the fan motor relay connectors (6P) in the control box. (See Photo 3)
- (4) Remove the 3 filter rails. (See Photo 1, 4)
- (5) Remove the fan guard. (See Photo 5)
- (6) Remove the lower casing. (See Photo 6)
- (7) Remove the green earth wire from the motor support. (See Photo 7)
- (8) Remove the 2 screws (M5 × 12) for motor support, and remove the left and right motor supports.
- (9) Remove the fan motor together with the sirocco fan.
- (10) Remove the 2 set screws (M6) to separate the fan motor from the sirocco fan.

Photo 6

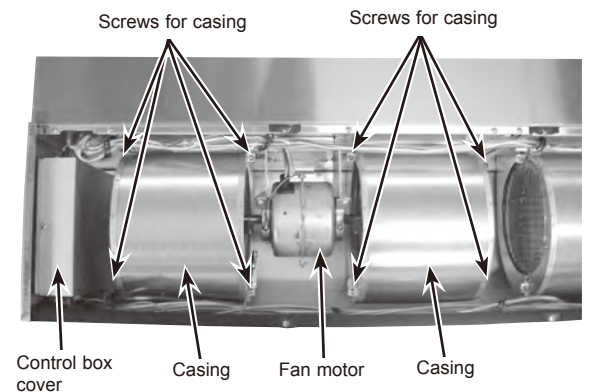
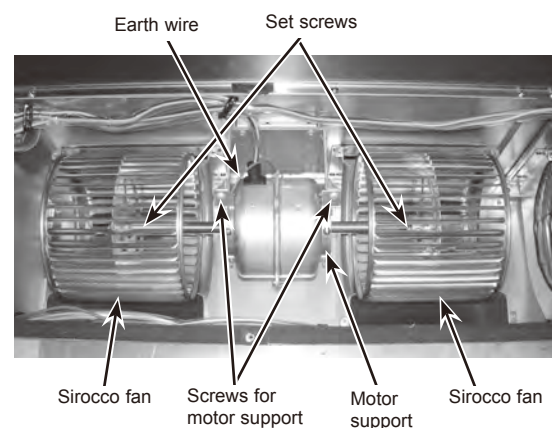

Photo 7



## OPERATING PROCEDURE

### 6. Removing the pipe temperature thermistor

- (1) Remove the oil filter. (See Figure 1)
- (2) Remove the fan guard. (See Photo 1)
- (3) Remove the terminal block box cover.
- (4) Remove the white relay connector (2P) in the terminal block box. (See Photo 8)
- (5) Remove the service panel. (See Photo 9)
- (6) Remove the pipe temperature thermistor from the holder. (See Photo 10)

#### Caution for installation

When installing the pipe temperature thermistor, slack off its lead wire as shown in the photo. Otherwise, water trickled down the lead wire may splash on the connector and this could cause a short circuit of the connector.

## PHOTOS

Photo 8

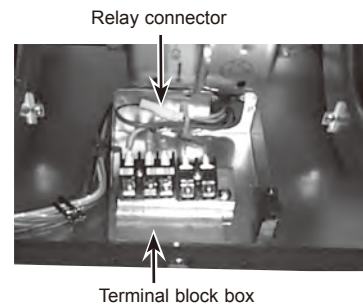

Photo 9

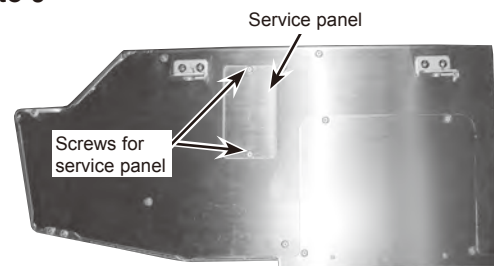
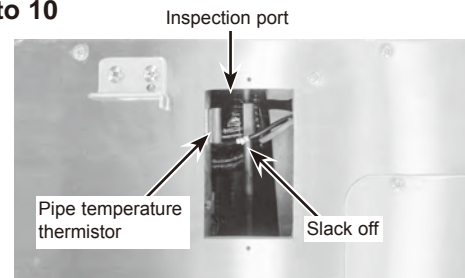

Photo 10



### 7. Removing the under panel

- (1) Remove the oil filter. (See Figure 1)
- (2) Remove the 3 filter rails. (See Photo 1, 4)
- (3) Remove the 12 screws (left: 1, right: 1, bottom: 10) for under panel, and remove the under panel. (See Photo 11)

Photo 11

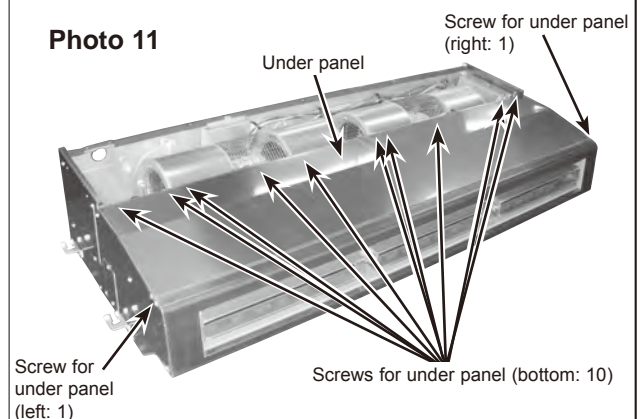

### 8. Removing the drain pan

- (1) Remove the oil filter. (See Figure 1)
- (2) Remove the 3 filter rails. (See Photo 1, 4)
- (3) Remove the under panel. (See Photo 11)
- (4) Pull the blue lead wire for cord heater towards you to slack off. (See Photo 12)
- (5) Remove the 3 screws at the center of the drain pan, and remove the drain pan.

Photo 12

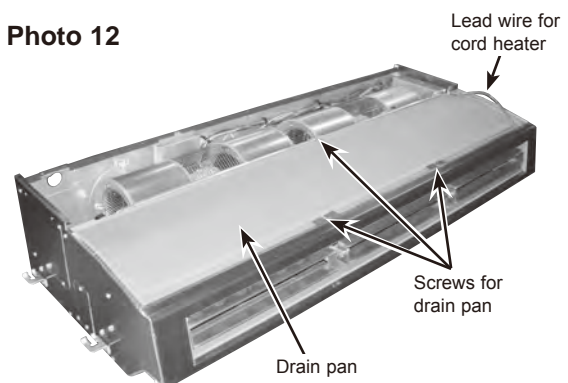

Note: Remove the drain pan carefully since the drain could remain in it.

## OPERATING PROCEDURE

### 9. Removing the guide vane

- (1) Remove the oil filter. (See Figure 1)
- (2) Remove the 3 filter rails. (See Photo 1, 4)
- (3) Remove the under panel. (See Photo 11)
- (4) Remove the drain pan. (See Photo 12)
- (5) Remove the 3 screws (4 × 10) for guide vane, and remove the guide vane. (See Photo 13)

Photo 13

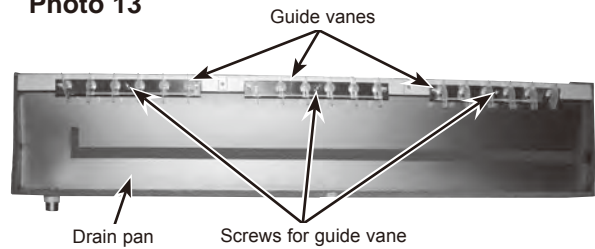

### 10. Removing the vane

- (1) Slide the vane to the center of the unit, and pull it towards you to remove. (See Photo 14)

#### Caution for installation

When installing the vane, check that its projection is on the left-rear side.

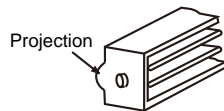
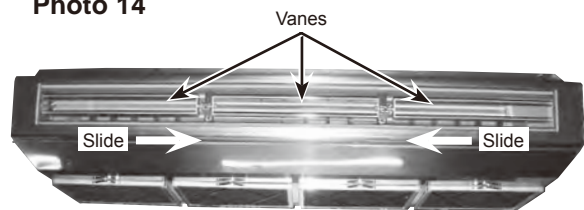

Photo 14



### 11. Removing the heat exchanger

- (1) Remove the oil filter. (See Figure 1)
- (2) Remove the 3 filter rails. (See Photo 1, 4)
- (3) Remove the under panel. (See Photo 11)
- (4) Remove the drain pan. (See Photo 12)
- (5) Remove the 2 screws (4 × 10) for pipe cover, and remove the pipe cover. (See Photo 15)
- (6) Remove the 3 screws (4 × 10, left: 2, right: 1) for heat exchanger. (See Photo 15, 16)
- (7) Remove the 2 screws (4 × 10) for heat exchanger at the top of the unit, and remove the heat exchanger. (See Photo 17)

Photo 15

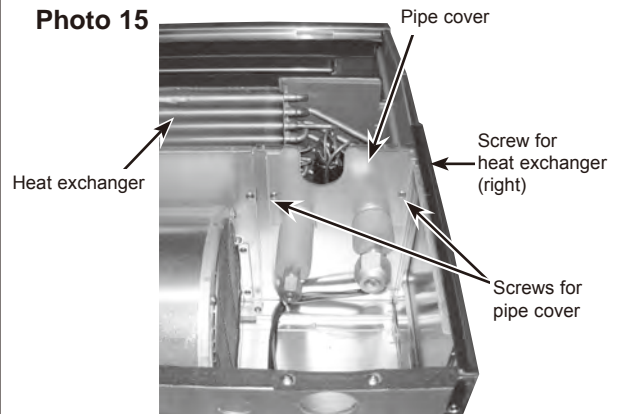

Photo 17

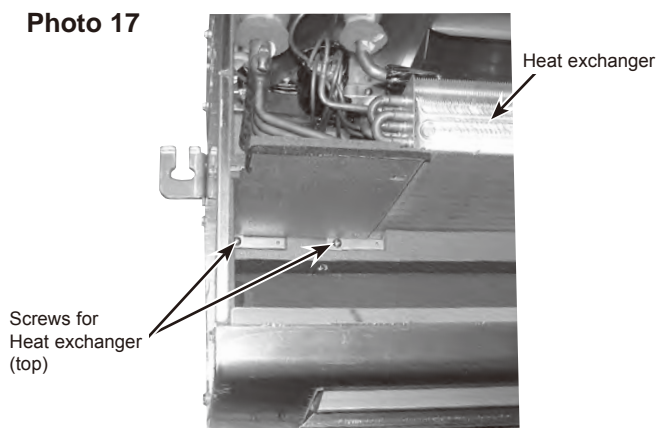
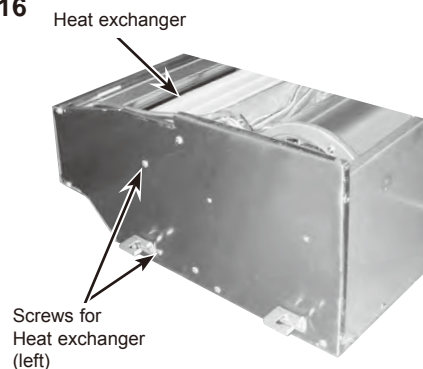

Photo 16



**Mr. SLIM™**

## **mitsubishi electric corporation**

HEAD OFFICE : TOKYO BLDG., 2-7-3, MARUNOUCHI, CHIYODA-KU, TOKYO 100-8310, JAPAN