

CITY MULTI Control System

# Smart ME Controller PAR-U02MEDA

Installation Manual

For distribution to dealers and contractors

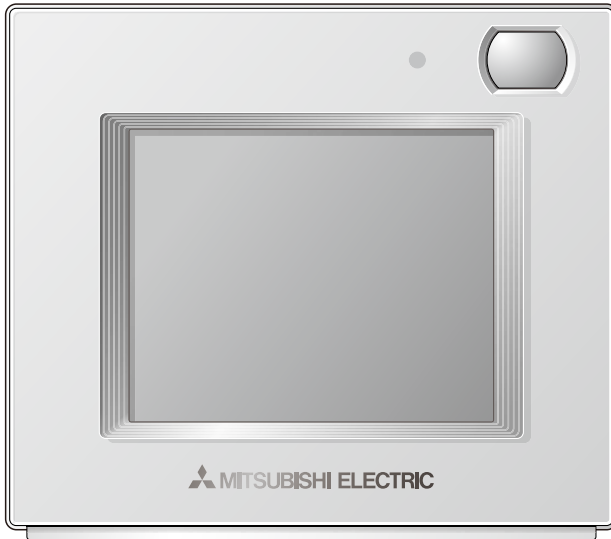

English

Français

Español

Italiano

Português

Ελληνικά

Türkçe

Slovenščina

Hrvatski

Română

Prior to use, thoroughly read the instructions in this manual to use the product correctly.  
Retain this manual for future reference.

Make sure that the CD-ROM, this manual, and Simple Operation Manual are passed on to any future users.

To ensure safety and proper operation of the remote controller, the remote controller should only be installed by qualified personnel.

# Chapter 1. Installation

This installation manual describes how to install the Smart ME Controller for use with Mitsubishi Building Air Conditioning System, direct expansion type CITY MULTI air conditioner indoor units (“-A” type and later).

Please be sure to read this installation manual and Instruction Book that are supplied with the Remote Controller before proceeding with the installation. Failure to follow the instructions may result in equipment damage.



For information on how to wire and install the air conditioning units, refer to the Air Conditioner Installation Manual.

After the installation, hand over this manual to users.

Smart ME Controller is a type of ME Remote Controllers, sometimes simply referred to as ME Remote Controller.

## 1 Safety Precautions

- Read the following safety precautions prior to installation.
- Observe these precautions carefully to ensure safety.

 <b>WARNING</b>	Indicates a risk of death or serious injury.
 <b>CAUTION</b>	Indicates a risk of serious injury or structural damage.

- After reading this manual, pass it on to the end user to retain for future reference.
- Keep this manual for future reference and refer to it as necessary. This manual should be made available to those who repair or relocate the controller. Make sure that the manual is passed on to any future users.

**All electric work must be performed by qualified personnel.**

### General precautions

#### **WARNING**

Do not install the unit in a place where large amounts of oil, steam, organic solvents, or corrosive gases, such as sulfuric gas, are present or where acidic/alkaline solutions or sprays are used frequently. These substances can compromise the performance of the unit or cause certain components of the unit to corrode, which can result in electric shock, malfunctions, smoke, or fire.

To reduce the risk of shorting, current leakage, electric shock, malfunctions, smoke, or fire, do not wash the controller with water or any other liquid.

To reduce the risk of electric shock, malfunctions, smoke or fire, do not operate the switches or touch other electrical parts with wet hands.

To reduce the risk of injury or electric shock, before spraying a chemical around the controller, stop the operation and cover the controller.

To reduce the risk of injury or electric shock, stop the operation and switch off the power supply before cleaning, maintaining, or inspecting the controller.

Properly install all required covers to keep moisture and dust out of the controller. Dust accumulation and water can cause electric shock, smoke, or fire.

To reduce the risk of injury, keep children away while installing, inspecting, or repairing the controller.

**⚠ CAUTION**

To reduce the risk of fire or explosion, do not place flammable materials or use flammable sprays around the controller.

To reduce the risk of damage to the controller, do not directly spray insecticide or other flammable sprays on the controller.

To reduce the risk of electric shock or malfunctions, do not touch the touch panel with a pointy or sharp object.

To reduce the risk of injury and electric shock, avoid contact with sharp edges of certain parts.

To avoid injury from broken glass, do not apply excessive force on the glass parts.

To reduce the risk of injury, wear protective gear when working on the controller.

Do not directly stare at the LED light, as this may damage your eyes.

**Precautions during installation**

**⚠ WARNING**

Do not install the controller where there is a risk of leaking flammable gas. If flammable gas accumulates around the controller, it may ignite and cause a fire or explosion.

Properly dispose of the packing materials. Plastic bags pose suffocation hazard to children.

Take appropriate safety measures against earthquakes to prevent the controller from causing injury.

To prevent injury, install the controller on a flat surface strong enough to support its weight.

**⚠ CAUTION**

To reduce the risk of shorting, current leakage, electric shock, malfunctions, smoke, or fire, do not install the controller in a place exposed to water or in a condensing environment.

Controller must be installed by qualified personnel according to the instructions detailed in the Installation Manual. Improper installation may result in electric shock or fire.

When attaching the cover and the top casing to the bottom casing, push it until it they click into place. If they are not properly locked into place, they may fall, causing personal injury, controller damage, or malfunctions.

**Precautions during wiring**

**⚠ WARNING**

To reduce the risk of damage to the controller, malfunctions, smoke, or fire, do not connect the power cable to the signal terminal block.

Properly secure the cables in place and provide adequate slack in the cables so as not to stress the terminals. Improperly connected cables may break, overheat, and cause smoke or fire.

To reduce the risk of injury or electric shock, switch off the main power before performing electrical work.

All electric work must be performed by a qualified electrician according to the local regulations, standards, and the instructions detailed in the Installation Manual. Capacity shortage to the power supply circuit or improper installation may result in malfunction, electric shock, smoke, or fire.

To reduce the risk of current leakage, overheating, smoke, or fire, use properly rated cables with adequate current carrying capacity.

**⚠ CAUTION**

To reduce the risk of electric shock, shorting, or malfunctions, keep wire pieces and sheath shavings out of the terminal block.

To reduce the risk of shorting, current leakage, electric shock, or malfunctions, keep the cables out of contact with controller edges.

To reduce the risk of electric shock, malfunctions, or fire, seal the gap between the cables and cable access holes with putty.

## Precautions for moving or repairing the controller

### WARNING

The controller should be repaired or moved only by qualified personnel.  
Do not disassemble or modify the controller.  
Improper installation or repair may cause injury, electric shock, or fire.

### CAUTION

To reduce the risk of shorting, electric shock, fire, or malfunction, do not touch the circuit board with tools or with your hands, and do not allow dust to accumulate on the circuit board.

## Additional precautions

To avoid damage to the controller, use appropriate tools to install, inspect, or repair the controller.

This controller is designed for exclusive use with the Building Management System by Mitsubishi Electric. The use of this controller for with other systems or for other purposes may cause malfunctions.

Take appropriate measures against electrical noise interference when installing the air conditioners in hospitals or facilities with radio communication capabilities. Inverter, high-frequency medical, or wireless communication equipment as well as power generators may cause the air conditioning system to malfunction. Air conditioning system may also adversely affect the operation of these types of equipment by creating electrical noise.

To avoid malfunctions, do not bundle power cables and signal cables together, or place them in the same metallic conduit.

To prevent malfunctions, do not remove the protective film or the circuit board from the casing.

To avoid damage to the controller, do not overtighten the screws.

Use a flat-head screwdriver with a blade width of 4-5.5 mm (5/32-7/32 in). The use of a screwdriver with a narrower or wider blade tip may damage the controller casing.

To prevent damage to the controller casing, do not force the driver to turn with its tip inserted in the slot.

To avoid discoloration, do not use benzene, thinner, or chemical rag to clean the controller. To clean the controller, wipe with a soft cloth soaked in water with mild detergent, wipe off the detergent with a wet cloth, and wipe off water with a dry cloth.

To avoid damage to the controller, provide protection against static electricity.

Do not use solderless terminals to connect cables to the terminal block.  
Solderless terminals may come in contact with the circuit board and cause malfunctions or damage the controller cover.

To avoid damage to the controller, do not make holes on the controller cover.

To avoid deformation and malfunction, do not install the remote controller in direct sunlight or where the ambient temperature may exceed 40°C (104°F) or drop below 0°C (32°F).

Do not install the controller on the control panel door. Vibrations or shocks to the controller may damage the controller or cause the controller to fall.

Hold the cables in place with clamps to prevent undue force from being applied to the terminal block and causing cable breakage.

To prevent cable breakage and malfunctions, do not hang the top controller casing hang by the cable.

## The CD-ROM that is supplied with Smart ME Controller

 **WARNING** The CD-ROM can only be played on a CD-drive or a DVD-drive. Do not attempt to play the CD-ROM on an audio CD player as this may damage your ears and/or speakers.

The CD-ROM that is supplied with the Smart ME Controller contains an Installation Manual and Instruction Book.

Each document is in PDF format.

Viewing documents requires a computer with Adobe® Reader® or Adobe® Acrobat® installed.

“Adobe® Reader®” and “Adobe® Acrobat®” are registered trademarks of Adobe Systems Incorporated.

## 2 Component names and supplied parts

The following parts are included in the box.

Parts name	Qty.
Remote controller (front cover) *1	1
Remote controller (top case) *1	1
Remote controller (bottom case)	1
Roundhead cross slot screws M4x30 *2	4
Wood screw 4.1x16 *2 (for direct wall installation)	4
Installation Manual (this manual)	1
Simple Operation Manual	1
CD-ROM (Installation Manual, Instruction Book)	1

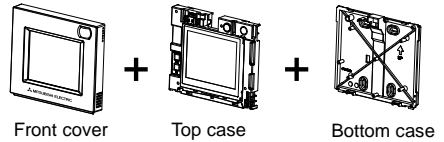

\*1 The front cover is already installed on the top case at factory shipment.

\*2 ISO metric screw thread

\*3 Remote controller cable is not included.

## 3 Field-supplied parts/Required tools

### (1) Field-supplied parts

Parts name	Qty.	Notes
Double switch box	1	Not required for direct wall installation
Thin metal conduit	As needed	
Locknut and bushing	As needed	
Cable cover	As needed	Required for routing remote controller cable along a wall
Putty	As needed	
Molly anchor	As needed	
Remote controller cable (0.3 mm <sup>2</sup> (AWG 22) 2-core sheathed cable)	As needed	If the remote controller cable exceeds 10 m (32 ft), use an electric wire that meets the following specification. CVVS: 1.25 mm <sup>2</sup> (standard AWG 16) or equivalent CPEVS: ø1.2 mm (standard AWG 16) or equivalent

### (2) Required tools

- Flat-tip screwdriver (Width: 4-5.5 mm (5/32-7/32 in))
- Knife or nipper
- Miscellaneous tools

## 4 System diagram

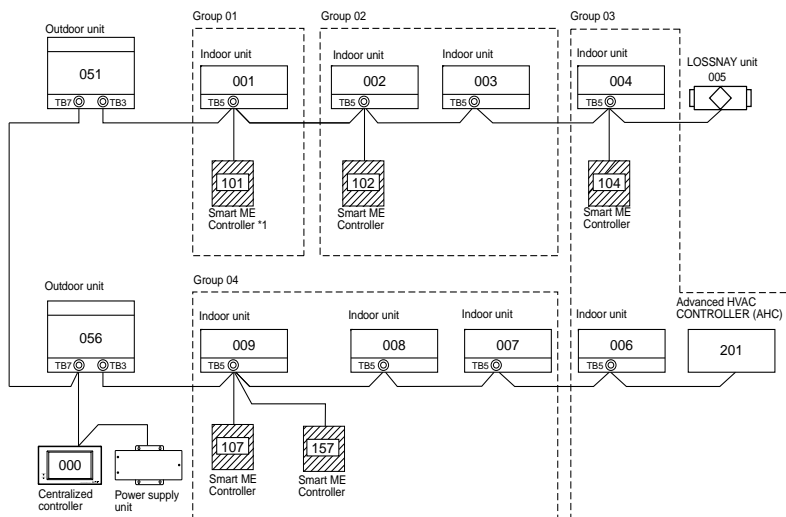

\*1 The power consumption coefficient of the Smart ME Controller is "0.5" and that of a ME Remote Controller (PAR-F27MEA) is "0.25".  
If the number of Smart ME Controllers is high and the total power supply they require exceeds the outdoor unit's ability to supply power, a Transmission booster (PAC-SF46EPA) will be required.

Outdoor unit	Transmission booster	Indoor unit	Smart ME Controller
32	25	1 (*1)	0.5

\*1: "7" for the P200 and P250 models

### (1) Wiring from the remote controller

- Connect to TB5 (terminal block for indoor-outdoor transmission cable) on any indoor unit in same M-NET system.
- The terminal block has no polarity. Connect to the terminals M1 and M2.

### (2) Operating in a group (Groups 01, 02, 03, and 04)

- Assign the lowest address to the main indoor unit in the group.  
The remote controller address should be set to a number that equals the main indoor unit address plus 100.

### (3) Up to two remote controllers (main and sub) can be connected to an indoor unit or a group of indoor units.

- Connect the main and sub remote controllers in the same way as described in (1) above.
- Be sure to set the main and sub remote controller addresses.  
The sub remote controller address should be set to a number that equals the main indoor unit address plus 150.

### ⚠ CAUTION

- Remote controllers cannot be wired together. Only one cable can be connected to the remote controller terminal block.
- The ME remote controller and MA remote controller cannot be connected in the same group.

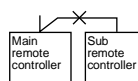

## 5 How To Install

This remote controller is for the wall installation. It can be installed either in the switch box or directly on the wall. When performing direct wall installation, cables can be thread through either back or top of the remote controller.

### (1) Selecting an installation site

Install the remote controller (switch box) on the site where the following conditions are met.

(a) A flat surface

(b) A place where the remote controller can measure the accurate room temperature and humidity  
Sensors to monitor the room temperature are on the indoor unit and on the remote controller.

When the room temperature is monitored with the sensor on the remote controller, the main remote controller monitors the room temperature. When using the sensor on the remote controller, follow the instructions below.

- To monitor the accurate room temperature and humidity, install the remote controller away from direct sunlight, heat sources, and the supply air outlet of the air conditioner.
- Install the remote controller in a location that allows the sensor to measure the representative room temperature and humidity.
- Install the remote controller where no wires are routed around the temperature sensor on the controller or where no obstacles block the air inlet, otherwise the sensor cannot measure accurate room temperature and humidity.
- After the controller has been exposed to high humidity (above 80%RH) for 60 hours, the humidity detection value will be offset by 3%RH. When the ambient humidity drops below 80%RH, the offset will be gradually cancelled.
- Do not install the controller where it is exposed to high concentration of acid, alkaline, or volatile organic compounds.
- If exposed to cigarette smoke for a long time, the humidity detection value will be offset.

(c) Install the remote controller where occupancy and brightness can be properly detected.

The remote controller has an occupancy sensor and a brightness sensor.

Each sensor has a sensor-detection zone.

- Install the remote controller where the coverage area covers the appropriate area in the room. The maximum distance the sensor can detect occupancy is approximately 10 m (32 ft).

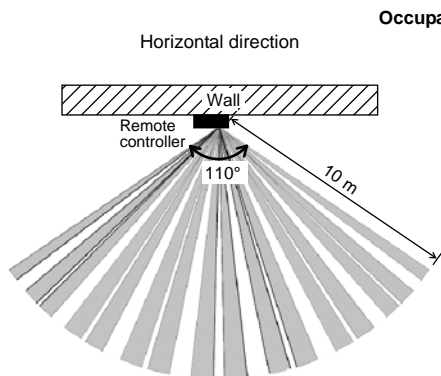

Figure 1

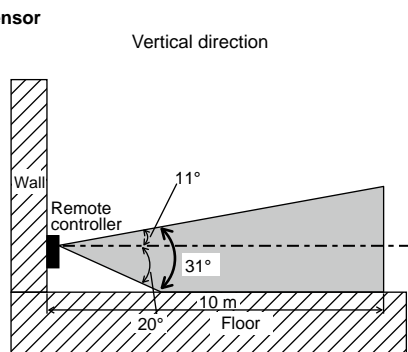

Figure 2

■: Detection area

\* As an inherent characteristic of the occupancy sensor, it is more sensitive to movements across the area indicated by ■ than to movements straight toward the sensor.

Occupancy sensor detects occupancy based on the temperature difference between the occupant and its surroundings.

To be precise, to enhance the sensitivity of the sensor to occupant movements, the occupancy sensor is designed to detect the changes in the amount of infrared light emitted from an object in the detection zone, including human bodies.

The occupancy sensor will not detect occupancy if no movements exist.

The sensor also becomes less sensitive to occupancy when the temperature difference between the occupant and its surroundings is small.

- Select the installation location carefully to avoid false detection.

Factors that contribute to false detection by the occupancy sensor

- Direct sunlight to the remote controller
- Supply air directed straight toward the remote controller
- Fireplace in the detection zone
- Portable heater (e.g., oscillating electric heater) in the detection zone
- Excessive vibrations or large impact inflicted on the remote controller
- Strong electrical noise
- Movements of small animals, such as cats and dogs

### Brightness sensor

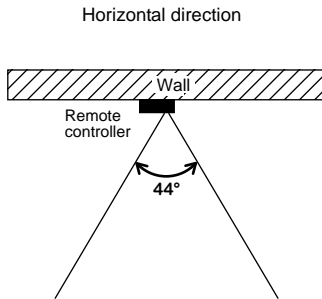

Figure 3

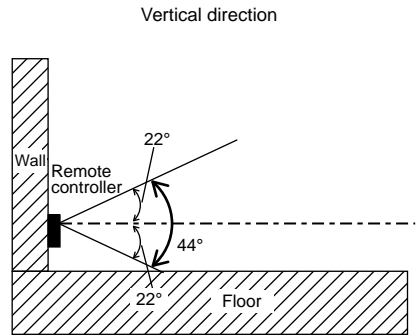

Figure 4

### Handling precautions

- Keep the lens scratch-free.
- Do not place adhesive tape or labels over the lens.
- Use a soft cloth to clean the lens.

### Important

Do not install the controller in a place where the difference between the remote controller surface temperature and the actual room temperature will be great.

If the temperature difference is too high, room temperature may not be adequately controlled.

To avoid deformation and malfunction, do not install the remote controller in direct sunlight, where the ambient temperature may rise above 40°C (104°F) or drop below 0°C (32°F), or where the relative humidity may rise above 90% or drops below 20%.

To reduce the risk of malfunctions, do not install the controller in a place where water or oil may come into contact with the controller, or in a condensing or corrosive environments.

Do not install the remote controller directly onto electrically conductive objects such as metal plate that has not been painted.

To use the Energy Saving Assist function in a system with both main and sub remote controllers, activate the function only on the remote controller whose coverage area is the largest.



## (2) Installation space

Leave a space around the remote controller as shown in the figure below, regardless of whether the controller is installed in the switch box or directly on the wall. Removing the remote controller will not be easy with insufficient space.

Also, leave an operating space in front of the remote controller.

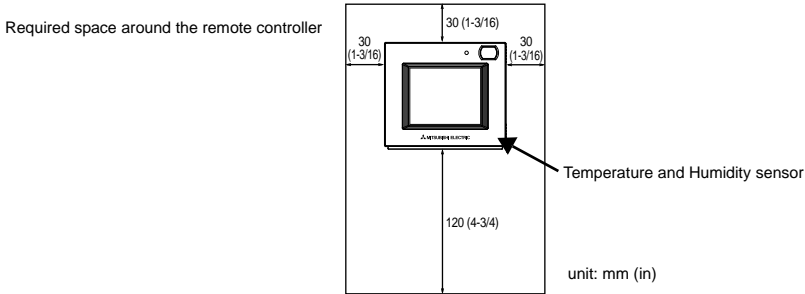

## (3) Installation work

### Important

Use caution when handling circuit boards to prevent damage from static electricity. Although the circuit board is covered with an insulation sheet, part of the circuit board is exposed. Use extra caution not to let your fingers come in contact with the circuit board.

The remote controller can be installed either in the switch box or directly on the wall. Perform the installation properly according to the method.

### ① Drill a hole in the wall.

#### ■ Installation using a switch box

- Drill a hole in the wall, and install the switch box on the wall.
- Connect the switch box to the conduit tube.

#### ■ Direct wall installation

- Drill a hole in the wall, and thread the cable through it.
  - \* No cable access hole is required when running the remote controller cable along the wall.

### ② Seal the cable access hole with putty.

#### ■ Installation using a switch box

- Seal the cable access hole at the connection of switch box and conduit tube with putty.

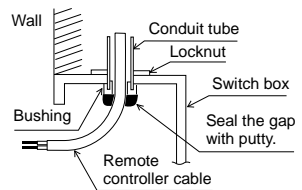

To reduce the risk of electric shock, malfunctions, or fire, seal the gap between the cables and cable access holes with putty.

### ③ Prepare the bottom case of the remote controller.

- \* Take the following procedure only when performing direct wall installation and running the remote controller cable along the wall.

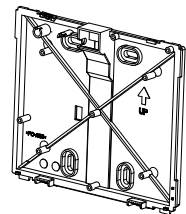

Bottom case

- Cut out the thin-wall part on the cover (indicated with the shaded area in the right figure) with a knife or a nipper.

**Note:**

Make sure that the hole edges are smooth and will not damage the wires.

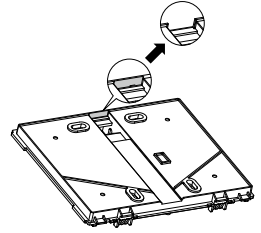

**④ Install the bottom case.**

- Remove the sheath as shown in the figure at right, and route the remote controller cable behind the bottom case. Install the bottom case.

■ Installation using a switch box

- Secure at least two corners of the switch box with screws.

■ Direct wall installation

- Secure at least two corners of the remote controller with screws.
- Be sure to secure top-left and bottom-right corners of the remote controller (viewed from the front) to prevent it from lifting. (Use molly anchor etc.)

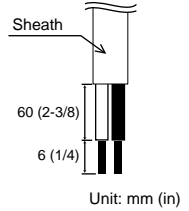

■ Installation using a switch box

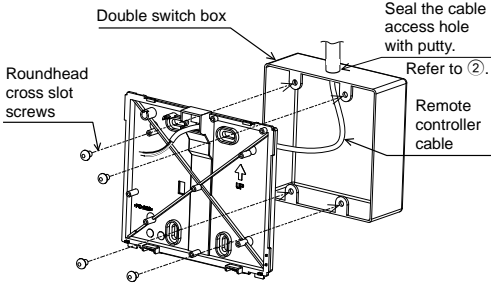

■ Direct wall installation

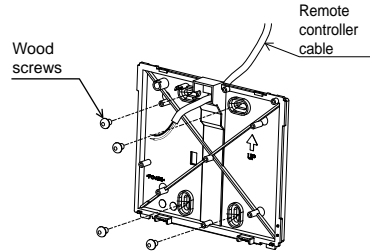

**Important**

To avoid damage to the controller, do not overtighten the screws.

To avoid damage to the controller, do not make holes on the controller cover.

**⑤ Install the top case on the bottom case.**

Two mounting tabs are at the top of the top case. Hook those two tabs onto the bottom case, and click the top case into place. Check that the case is securely installed and not lifted.

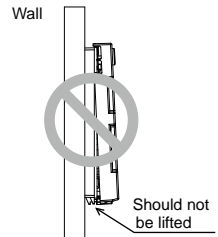
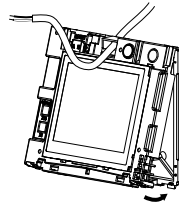

\* The controller is shipped with the front cover mounted to the top case. Remove the front cover from the top case before installing the top case on the wall. Refer to “① Uninstalling the front cover” on page 12.

⑥ **Connect the remote controller cable to the terminal block on the top case.**

Connect the remote controller cable to the terminal block.

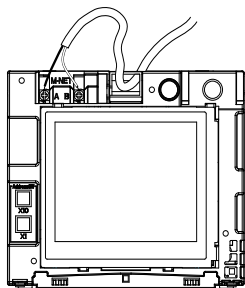

Connect the cable to the terminal block, and insert the cable into the groove.

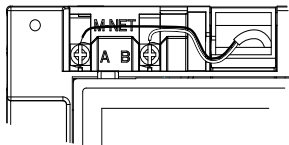
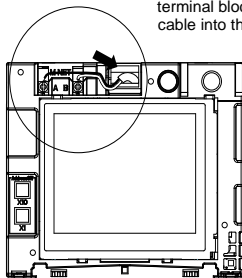

To reduce the risk of electric shock, shorting, or malfunctions, keep wire pieces and sheath shavings out of the terminal block.

**Important**

Do not use solderless terminals to connect cables to the terminal block. Solderless terminals may come in contact with the circuit board and cause malfunctions or damage the controller cover.

Hold the cables in place with clamps to prevent undue force from being applied to the terminal block and causing cable breakage.

- \* Take the following procedure only when performing direct wall installation and drilling a hole in the wall.
- Seal the hole through which the cable is threaded with putty.

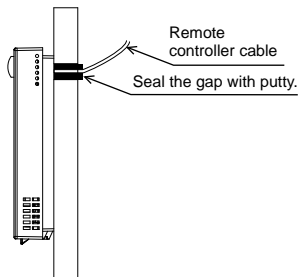

⑦ Set the M-NET addresses.

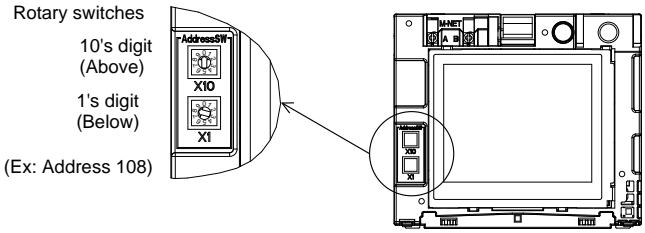

(Ex: Address 108)

	Address range	Address setting method
Main remote controller	101 to 150	Address that equals the lowest address of the group plus 100
Sub remote controller	151 to 200	Address that equals the lowest address of the group plus 150

Rotary switch setting	Address
01 to 99	101-199 with the 100's digit automatically set to 1
00	200

\* The factory setting for the rotary switches is 01.

\*\* M-NET address can be changed with or without the power being applied to the controller. The screen will jump to the [Start-up] screen.

Group information for indoor units and AHC units will be deleted, but the rest of the information will be retained.

**Important**

To set the address, turn the rotary switch with a precision slotted screwdriver [(-), 2.0 mm (1/16 in) (W)] to a torque of less than 19.6 N to avoid the damage to the rotary switches.

⑧ Install the front cover on the top case.

Two mounting tabs are at the top of the front cover.

Hook those two tabs onto the top case, and click the front cover into place. Check that the case is securely installed and not lifted.

**Important**

When attaching the front cover to the top case, push it until it they click into place. If they are not properly locked into place, they may fall, causing personal injury, controller damage, or malfunctions.

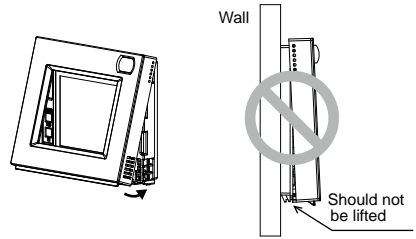

- Direct wall installation (when running the cable along the wall)
  - Thread the cable through the access hole at the top of the remote controller.
  - Seal the cut-out part of the cover with putty.
  - Use a cable cover.

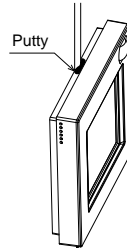

Installation is complete.  
Follow the instructions below when uninstalling them.

## • Uninstalling the front cover and top case

### ① Uninstalling the front cover

Insert a flat-tip screwdriver (with a blade width of 5.5 mm (7/32 in) or less) into either of the two latches at the bottom of the remote controller as shown in the figure at right.

Lightly push the tip of the flat-head screwdriver in the direction of the arrow in the figure to remove the front cover.

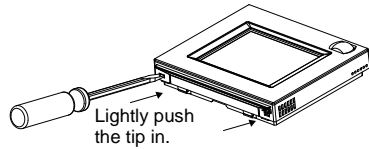

### ② Uninstalling the top case

Insert a flat-tip screwdriver (with a blade width of 5.5 mm (7/32 in) or less) into either of the two latches at the front of the remote controller as shown in the figure at right.

Push the tip of the flat-head screwdriver in the direction of the arrow in the figure to remove the top case.

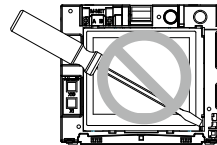
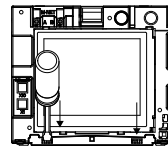

## Important

Use a flat-head screwdriver with a blade width of 4-5.5 mm (5/32-7/32 in). The use of a screwdriver with a narrower or wider blade tip may damage the controller casing.

To prevent damage to the controller casing, do not force the driver to turn with its tip inserted in the slot.

To prevent damage to the control board, do not insert the driver into the slot strongly.

## 6 Important

### ■ Discrepancy between the room temperature measured at the wall and the actual room temperature may occur.

If the following conditions are met, the use of the temperature sensor on the indoor unit is recommended.

- Air distribution in the space is poor.
- There is a great discrepancy between the wall temperature and the actual room temperature.
- The back side of the wall is directly exposed to the outside air.

**NOTE: When temperature changes rapidly, the temperature may not be detected accurately.**

### ■ Refer to the following manual for temperature sensor setting: indoor unit Installation Manual for City Multi.

### ■ At the time of factory shipment, protective sheet is on the operation interface of the front cover.

Peel off the protective sheet on the operation interface prior to use.

# Chapter 2. Initial Setting

This chapter contains information about the settings to be made at the time of installation. Please read the instructions carefully and make the settings accordingly. Refer to Chapter 1 "Installation" for how to install the Remote Controller, and refer to the air conditioning unit installation manuals for how to connect the controller cable to the air conditioning units, or how to install the air conditioning units. Please remember to give all manuals to the end users after installation is complete.

## 1 Initial Settings

### (1) Initial startup settings

Before turning on the controller, first make sure that the controller, indoor units, and outdoor units have been installed properly according to the instructions detailed in the respective manuals. Turn on the controller and the units.

- This manual is intended for the first startup after the unit has been shipped from the factory. If the setting has been changed even once, the popup window or setting screens explained below may not appear.

(a) The Language screen will appear.

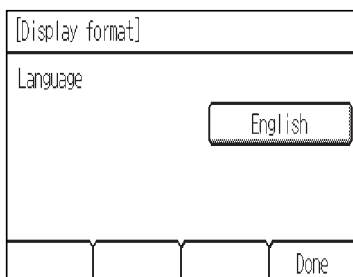

- ① Touch the button to select the language of your choice.
- ② Touch the [Done] button.

(b) The Start-up screen will appear.

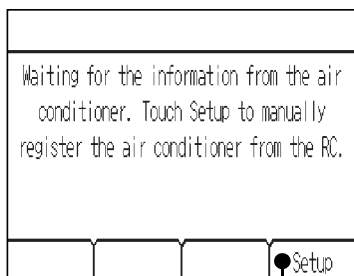

#### [Case 1] Basic setup (including the setup performed at the time of system controller connection)

The screen will automatically jump to the HOME screen after a while.

Change the initial settings information as necessary. (Refer to section 2 "Service Menu.")

\*This screen will not appear if the Basic setup has already been completed.

#### [Case 2] Manual setup from the controller

Touch the [Setup] button to access the [Setup] screen.

When done making the settings for the "Group setting" and "Interlocked LOSSNAY," touch [Back] to startup the system and return to the Home screen. It may take about 7 minutes until the screen [General equipment] becomes accessible.

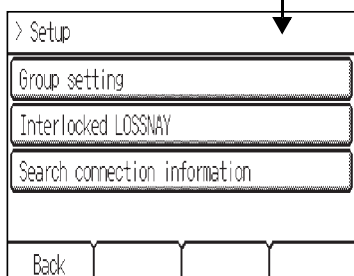

## (2) Setup screen

### (a) Group setting

Use this screen to register the indoor units and the AHC to be controlled from the controller.

[Group setting]			
IC	Address	▼ 001 ▲	▲
001 002 003 004	Unit	IC	
005 006 007 008	Function	Set Del	
009 010 011 012			
013 014 015 016			
AHC 201			
Back			

- ① Select an indoor unit or an AHC address in the [Address] field.

The number of units that can be registered.  
Indoor unit: 16 units maximum  
AHC: 1 unit maximum

\* AHC cannot be controlled from the controller unless indoor units are registered with the system.

- ② Touch the [Set] button to register the address, and [Del] to delete the address.

• Successful address registration/deletion:  
The registered address(es) will appear on the left side of the screen.  
Deleted address will not appear on the screen.

• Error:  
"Request denied." or "Is not to be connected" will appear.

### (b) Interlocked LOSSNAY

Use this function to interlock the operation of indoor units and LOSSNAY units.

[Interlocked LOSSNAY]			
001 IC 007 IC	Add. 1	▼ 001 ▲	▲
002 IC 008 IC	Add. 2	▼ 013 ▲	▲
003 IC 009 IC	Function	Set Conf Del	
004 IC 010 IC			
005 IC 011 IC			
006 IC 012 IC			
Back			

- ① To register LOSSNAY units

Select the indoor unit address in the Add. 1 section.

Select the interlocked LOSSNAY address in the Add. 2 section. Touch the [Set] button to save the setting.

- ② To search for an interlocked setting

Touch the [Conf] button to display in the left column the addresses of the units that are interlocked with the unit whose address was set in the Add. 1 section.

- ③ To delete the interlock settings

After taking Step ② above, select the address to be deleted in the Add. 2 section, and then touch the [Del] button.

When the setting or deletion is successfully completed, "Completed" will appear below [Function] field on the screen.

If setting or deletion fails, "Request denied" will appear below [Function] field on the screen.

### (c) Search connection information

Use this screen to specify a unit and search for the controllers that are connected to the unit.

[Search connection information]			
001 IC	Address	▼ 051 ▲	▲
002 IC			
003 IC	Function	Conf	
004 IC			
005 IC			
006 IC			
Back			

- ① Select an address in the [Address] field.

- ② Touch the [Conf] button to search for the interlocked units.

The results will appear in the left column. (When multiple units are found, the addresses that do not fit on the first page will appear on the successive pages.)

• Search error:  
"Request denied." will appear.

After completing the settings, touch the [Back] button on the [Setup] screen. The message "Collecting the information from the air conditioner." will appear, and then the screen will jump to the HOME screen. This signals the completion of the setup process.

Access the Service Menu from the HOME screen to make the settings for other items as necessary.



## 2 Service Menu

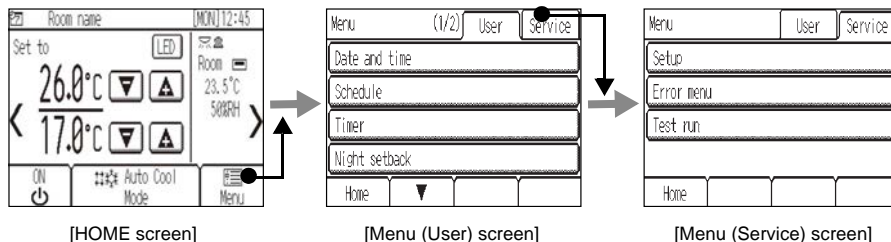

A password is required to access the Menu (Service) screen or some settings under the Menu (User) screen.

- The initial Service password is “9999.” The initial User password is “0000.” Change the password as necessary to prevent unauthorized access.
- Make sure the password is available to the maintenance and other necessary personnel.
- The password can be changed to any four-digit number. On the [Login page], enter the old password, touch the [Change] button, and then enter a new password.
- If you forget your password, log in with the master password.  
Master service and user password: 1056

### ■Service menu items

Item	Detail	Description	Setting	Default	
(1)	Setup	(a) Group setting	Make the group setting for the indoor units, and an AHC	Refer to section 1 "Initial Settings" (2) "Setup screen".	-
		(b) Interlocked LOSSNAY	Enters the interlock settings between indoor and LOSSNAY units		
		(c) Search connection information	Use to search and display the units that are connected to a specified unit.		
		(d) Cool/Heat display	Use to show or hide the operation mode signs (Cool/Heat) on the HOME screen while the units are operated in the Auto mode.	Select between Show/Hide.	Auto: Show
		(e) Temperature sensor offset	Use to offset the reading on the built-in temperature sensor. *1	Set the offset value. (-5°C~+5°C) (-10°F~+10°F)	Offset: 0.0°C (0°F)
		(f) Humidity sensor offset	Use to offset the reading on the built-in humidity sensor.	Set the offset value. (-10%~+10%)	Offset: 0%
		(g) Room name	Use to enter room names (max. 16 characters). The names entered here will appear on the HOME screen.	Use a combination of capital letters, small-case letters, numerical characters and symbols.	Blank
		(h) Telephone number	Use to enter the telephone number of the maintenance personnel (max. 13 numbers). This number will be displayed on the screen that appears when an error occurs.	Use numerical characters and hyphens.	Blank
		(i) IC function setting	Use to make the settings for the indoor units from the controller. * Refer to the indoor unit installation manual for the detailed explanation of the setting items.	To be explained later	-

Item	Detail		Description	Setting	Default	
(1)	Setup	(j)	LED color adjustment	Adjusts the LED indicator color. *2	Sets the R (Red), G (Green), B (Blue) color ratio.	Blue: R, G, B=0, 0, 100 L.Blue: R, G, B=0, 40, 60 Purple: R, G, B=40, 0, 100 Red: R, G, B=100, 0, 0 Pink: R, G, B=80, 20, 40 Orange: R, G, B=100, 40, 0 Yellow: R, G, B=60, 80, 0 Green: R, G, B=0, 100, 0 Lime: R, G, B=40, 100, 0 White: R, G, B=80, 100, 40
		(k)	Reset RC	Use to initialize the memory on the controller. *3	Touch the Reset button.	—
		(l)	AHC port name *4	Use to customize the AHC port names (max. 20 characters). These names can be reset to the default names.	Set button: Jumps the screen to the AHC port renamed screen. Reset button: Changes all the port names to the default names.	Blank
(2)	Error menu	(a)	Self check	Use to check the error history of the desired unit and to reset the error history.	Sets the monitor targets and displays error history. Reset button: Deletes the error history.	—
(3)	Test run		Use to test the air conditioning units. (Except AHC) Liquid pipe temperature of indoor unit will appear during the test run. The test-run will automatically end in two hours.	Test-run Displays the liquid pipe temperature of the indoor unit at the specified address.	—	

\*1 This setting will not become effective if the temperature sensor on the indoor unit is activated.

\*2 The LED indicates the operation status of air conditioning units in colors. Refer to "LED Indicator" in the instructions book.

\*3 All settings information will be cleared to the default.

\*4 AHC port name will not appear if no AHC unit is registered in the group.

#### [Data backup during power failure]

All the data for items except items (1)-(k) Reset RC and (3) Test run are nonvolatile, and will be backed up even during power failure.

Data for items (1)-(a), (b), (c), (i), and (2)-(a) will be backed up on the air conditioning unit side.

## (1) Setup menu

- (a) Group setting  
Refer to section 1 "Initial Settings" (2) "Setup screen".
- (b) LOSSNAY interlock  
Refer to section 1 "Initial Settings" (2) "Setup screen".
- (c) Search connection information  
Refer to section 1 "Initial Settings" (2) "Setup screen".
- (d) Cool/Heat display

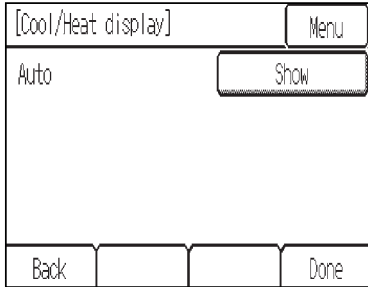

### (e) Temperature sensor offset

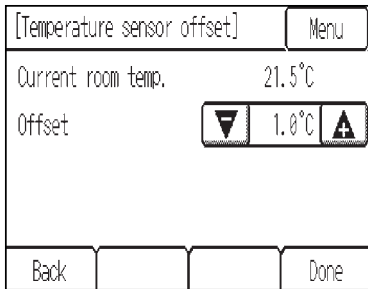

### (f) Humidity sensor offset

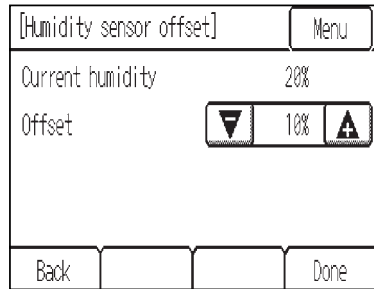

\* The temperature in the [Current room temp.] field indicates the temperature measured by the built-in temperature sensor on the remote controller.

\*\* When the offset value is changed, it may take up to 1 minute until the change is reflected on temperature display on the Home screen.

\* The humidity in the [Current humidity] field indicates the humidity measured by the built-in humidity sensor on the remote controller.

### (g) Room name

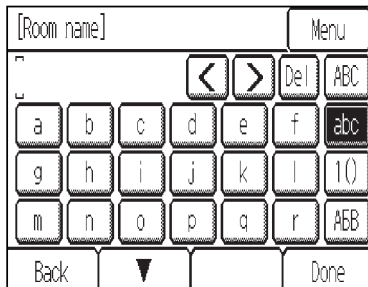

(max. 16 characters)

(h) Telephone number

[Telephone number]			Menu
0-12-345-6789			< > Del
1	2	3	4
5	6	7	8
9	0	-	
Back			Done

(max. 13 numbers)

(i) IC function setting

[IC Function settings]		Menu
M-NET address	▼ 001 ▲	
Function number	▼ 100 ▲	
Function setting	▼ 1 ▲	
Function	Set Conf	
Back		

- ① Select the indoor unit address in the [M-NET address] field. (When [Grp] has been selected, all the indoor units that are controlled from the controller will be selected.)
- ② Select the desired function number in the [Function number] field.
- ③ Touch the [Conf] button to confirm the current settings. Indoor units will acquire the current settings, and the results will appear in the [Function setting] field.
- ④ Select the number\* that corresponds to the desired function to be configured in the [Function setting] field.  
\* Refer to the manuals that came with the indoor unit.
- ⑤ Touch the [Set] button to save the setting to the indoor unit.
  - Successful completion:  
"Completed" will appear.
  - Error:  
"Request denied." will appear.

(j) LED color adjustment

[LED color adjustment]		Menu
Color	White	
Red	▼ 042 ▲	
Green	▼ 070 ▲	
Blue	▼ 028 ▲	
Back		Reset Done

R (Red), G (Green), B (Blue): "+"...Darken, "-"...Lighten  
Reset: Restores the default settings for the display color.

(k) Reset RC

[Reset RC]			Menu
RC settings will be reset.			
Back			Reset

(l) AHC port name

>> AHC port name (1/4)			Menu
D001 Heater 1	Edit		
D002 Heater 2	Edit		
D003 Humidifier	Edit		
D004 Fan	● Edit		
Back	▼		Reset

[AHC Port Name]			Menu
[ ]			< > Del ABC
a	b	c	abc
g	h	i	1()
m	n	o	AEB
Back	▼		Done

(max. 20 characters)

(2) Error Menu

(a) Self check

[Self check]			Menu
M-NET address	▼	001	▲
Back			● Conf

[Self check]			Menu
M-NET address	001		
Error code	1302		
Unit	0C		
Unit address	051		
Back			Reset

### (3) Test Run

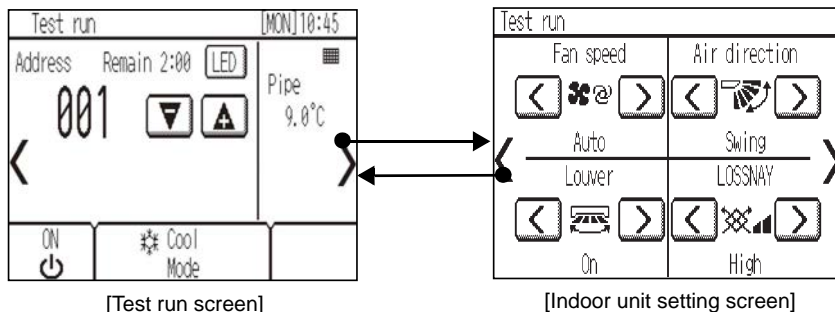

[Test run screen]

[Indoor unit setting screen]

- (a) Read the section about Test run in the indoor unit Installation Manual before performing a test run.
- (b) During the test run, indoor units will be forced to operate in the Thermo-ON status.  
Except the set temperature, normal operation functions are accessible during test run.
- (c) By selecting the address of another indoor unit, the liquid pipe temperature of the selected unit can be monitored.
- (d) The test run will automatically end in two hours.

\* When AHC is controlled from the controller

To monitor the operating status of AHC, touch the [<] button on the [Test run] screen and access the [General equipment] screen.

To set the humidity setting for the humidifier (when one is connected to the AHC), touch the [>] button on the [Indoor unit setting] screen.

Specifications			
Power Source		17-32 VDC *1 (for connection to M-NET only)	Receives power from outdoor units via the M-NET transmission cable. The power consumption coefficient*2 of the Smart ME Controller is "0.5".
Operating conditions	Temperature	Operating temperature range	0°C – +40°C (+32°F – +104°F)
		Storage temperature range	-20°C – +60°C (-4°F – +140°F)
	Humidity	20%–90% RH (Non-condensing)	
Weight		0.3 kg (11/16 lbs)	
External dimensions (W x H x D)		140 x 120 (123) x 25 (28.8) mm 5-17/32 x 4-3/4 (4-27/32) x 1 (1-5/32) in  * The numbers in the parenthesis indicate the dimensions including the protruding parts.	

\*1 Not for use with a generic DC power supply device.

\*2 "Power consumption coefficient" is a coefficient to calculate the relative power consumption of the devices that receive power through the M-NET transmission cable.  
Refer to section 4 "System diagram" in Chapter 1 in this Manual.

**Note:**  
This equipment has been tested and found to comply with the limits for a Class B digital device, pursuant to Part 15 of the FCC Rules. These limits are designed to provide reasonable protection against harmful interference in a residential installation. This equipment generates, uses and can radiate radio frequency energy and, if not installed and used in accordance with the instructions, may cause harmful interference to radio communications. However, there is no guarantee that interference will not occur in a particular installation. If this equipment does cause harmful interference to radio or television reception, which can be determined by turning the equipment off and on, the user is encouraged to try to correct the interference by one or more of the following measures:

- Reorient or relocate the receiving antenna.
- Increase the separation between the equipment and receiver.
- Connect the equipment into an outlet on a circuit different from that to which the receiver is connected.
- Consult the dealer or an experienced radio/TV technician for help.

---

This product is designed and intended for use in the residential, commercial and light-industrial environment.

The product at hand is based on the following EU regulations:

- Electromagnetic Compatibility Directive 2004/108/EC
- Restriction of Hazardous Substances 2011/65/EU

Please be sure to put the contact address/telephone number on this manual before handing it to the customer.

**MITSUBISHI ELECTRIC CORPORATION**

HEAD OFFICE: TOKYO BLDG., 2-7-3, MARUNOUCHI, CHIYODA-KU, TOKYO 100-8310, JAPAN

Authorized representative in EU: MITSUBISHI ELECTRIC EUROPE B.V.

HARMAN HOUSE, 1 GEORGE STREET, UXBRIDGE, MIDDLESEX UB8 1QQ, U.K.