

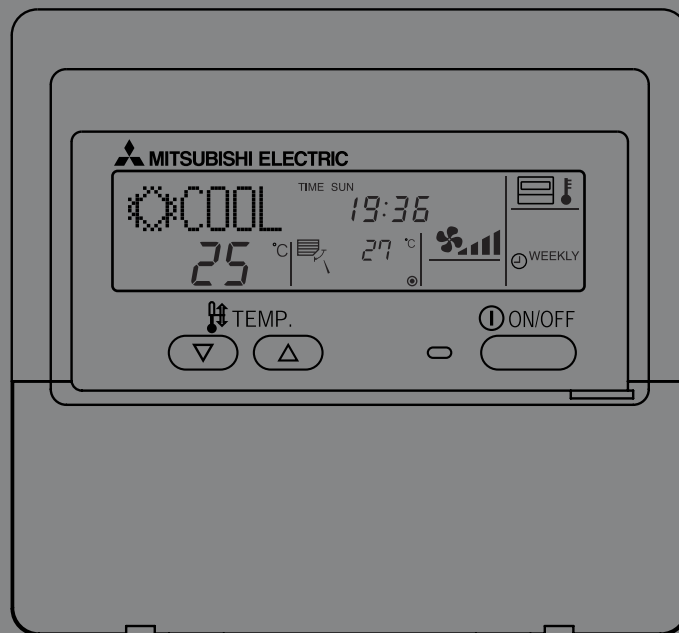

**CITY MULTI and Mr.SLIM
Air Conditioners**

**MA Remote Controller
PAR-21MAA**

TECHNICAL MANUAL



Mr.SLIM

<REVISED>

CONTENTS

| | |
|--|-----------|
| I . Advantage of New MA Remote Controller..... | 2 |
| 1. Weekly Timer | 2 |
| 2. Easy Maintenance Function (Only for PUHZ type)..... | 2 |
| 3. New Display | 3 |
| 3.1 Dot Liquid Crystal Display (LCD)..... | 3 |
| 3.2 Multi-language Display | 3 |
| 4. The Other Functions | 3 |
| 4.1 Temperature Range Limit Setting | 3 |
| 4.2 Auto Off Timer..... | 3 |
| 4.3 Simple Operation Lock | 3 |
| II . New Functions | 4 |
| III . Appearance | 5 |
| 1. Display Section | 5 |
| 2. Operation Section | 5 |
| IV . Easy Maintenance Function (Only for Mr. SLIM PUHZ series)..... | 6 |
| 1. Maintenance Mode Operating Method..... | 6 |
| 2. Guide for Operation Condition | 8 |
| Check Points..... | 8 |
| V . How to Select Functions of remote controller..... | 9 |
| 1. Function Items | 9 |
| 2. Flowchart of Function Setting | 10 |
| 3. Screen Structure for Function Setting | 11 |
| 4. Function Setting Mode | 12 |
| 4.1 Change Language | 12 |
| 4.2 Function Setting..... | 14 |
| 4.2.1 Operation Lock (Operation Function Limit Setting)..... | 14 |
| 4.2.2 Auto Mode Setting..... | 16 |
| 4.2.3 Temperature Range Limit Setting..... | 18 |
| 4.3 Basic Functions Setting | 20 |
| 4.3.1 Remote Controller Main/Sub Setting..... | 20 |
| 4.3.2 Timer function setting (Weekly timer/Auto off timer/Simple timer) | 21 |
| 4.3.3 Contact Number Setting for Error Situation..... | 33 |
| 4.4 Display Change Setting | 35 |
| 4.4.1 Temperature Display °C/°F Setting | 35 |
| 4.4.2 Room Temperature Display Setting | 36 |
| 4.4.3 Automatic Cooling/Heating Display Setting | 37 |
| VI . Unit Function Setting by the Remote Controller (for Mr. SLIM) | 38 |
| VII . Test Run by the Remote Controller (for Mr. SLIM) | 42 |
| 1. Check Points Under Test Run | 42 |
| 2. Test Run using the Wired Remote Controller..... | 42 |
| VIII . Self-Diagnosis by the Remote Controller (for Mr. SLIM)..... | 44 |
| 1. How to Proceed "Self-diagnosis" | 44 |
| 1.1 When a Problem Occurs During Operation | 44 |
| 1.2 Self-Diagnosis During Maintenance or Service | 44 |
| 1.3 Remote Controller Diagnosis..... | 45 |
| 2. Error Code List..... | 46 |
| IX . Monitoring the Operation Data by the remote Controller (for Mr. SLIM)..... | 48 |
| 1. How to "Monitor the Operation Data" | 48 |
| 2. Request Code List | 49 |
| 2.1 Detail Contents in Request Code | 53 |
| X . System Control (for Mr. SLIM) | 58 |
| 1. 1-Remote Controller (Standard) Operation..... | 60 |
| 1.1 1 Wired Remote Controller | 60 |
| 1.2 Wireless Remote Controller | 60 |
| 2. 2-Remote Controller Operation..... | 61 |
| 2.1 2 Wired Remote Controllers | 61 |
| 2.2 2 Wireless Remote Controllers | 61 |
| 2.3 1 Wired and 1 Wireless Remote Controller | 61 |
| 3. Group Control Operation (Collective Operation and Control of Multiple Refrigerant Systems (2 to 16))..... | 62 |
| 4. Rotation function (and back-up function, 2nd stage cut-in function) | 63 |
| 4.1 Operation..... | 63 |
| 4.2 How to set rotation function(back-up function, 2nd stage cut-in function) | 64 |
| XI . External Dimensions | 66 |

I . Advantage of New MA Remote Controller

II . New Functions

III . Appearance

IV . Easy Maintenance Function (For Mr. SLIM PUHZ series)

V . How to Select Functions of remote controller

VI . Unit Function Setting by the Remote Controller (for Mr. SLIM)

VII . Test Run by the Remote Controller (for Mr. SLIM)

VIII . Self-Diagnosis by the Remote Controller (for Mr. SLIM)

IX . Monitoring the Operation Data by the remote Controller (for Mr. SLIM)

X . System Control (for Mr.SLIM)

XI . External Dimensions

I . Advantage of New MA Remote Controller

1. Weekly Timer

The built-in weekly timer enables you not only to make on/off settings but also temperature settings. Up to 8 patterns can be set for each day of the week.

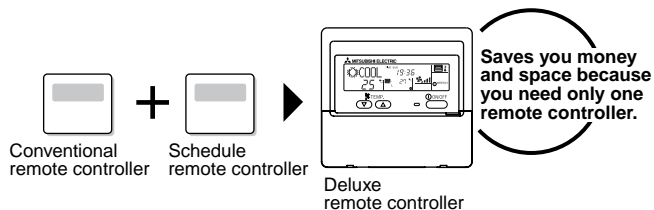

Setting example (Restaurant in summer)

Economical operation according to air conditioner use

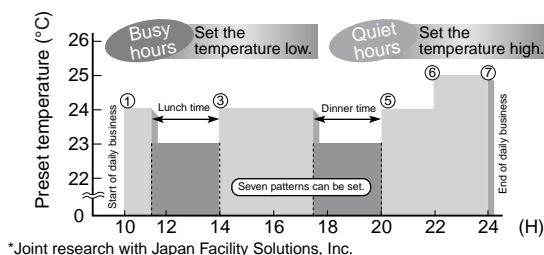

2. Easy Maintenance Function (Only for PUAZ type)

Enables you to check necessary data on site, drastically reducing the time required for maintenance work.

◆ Information useful for maintenance can be displayed on the remote controller.

Outdoor unit information can be checked even from inside a building.

Furthermore, use of maintenance stable-operation control that fixes the operating frequency, allows smooth inspection, even for inverter models.

<Display information> Outputs data for nine items.

| Compressor information | Outdoor unit information | Indoor unit information |
|---|--|---|
| <ul style="list-style-type: none"> Accumulated operating time Number of ON/OFF times Operating current | <ul style="list-style-type: none"> Heat exchanger temperature Discharge temperature Outside air temperature | <ul style="list-style-type: none"> Heat exchanger temperature Room temperature Filter operating time |

◆ The contact telephone number to be called when an error occurs is displayed automatically.

This helps smooth contact with appropriate personnel when an error occurs.

The contact telephone number of the maintenance company to be called when an error occurs can be registered in advance. When an error occurs, the contact telephone number will automatically appear, allowing you to call without difficult .

Displays the contact number in case of abnormality.

CHECK

Displayed alternately

CALL · XXX
XXXXXXX

Telephone number registered in advance

3. New Display

Various information is displayed and conveyed clearly, enabling more accurate operation of the air conditioner.

3.1 Dot Liquid Crystal Display (LCD)

The dot liquid crystal display enables quick understanding of the operation state.

● Display example [Operation mode]

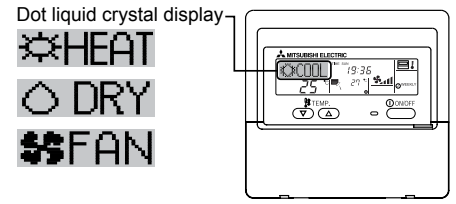

3.2 Multi-language Display

In addition to English, contents can be displayed in 7 other languages.

This function makes the remote controller very useful in facilities where foreigners are present.

● Display example [Cool mode]



4. The Other Functions

4.1 Temperature Range Limit Setting

Enables operation of air conditioner at comfortable temperatures at all times.

Upper and lower limits can be established for the temperature setting. This prevents overcooling or overheating, thereby contributing to energy saving.

4.2 Auto Off Timer

Shuts off wasteful air conditioner operations.

Operation is stopped automatically when the preset time elapses following the start of operation, thereby preventing wasteful operations.

The time can be set from 30 minutes to 4 hours in 30-minute increments.

4.3 Simple Operation Lock

Prevents others from changing settings without permission.

This lets you disable all the buttons or all the buttons except for the [ON/OFF] button, preventing mischief and incorrect operations.

II . New Functions

| Function | Description | Available when connect | | Go to page |
|---|---|------------------------|----------------------------|------------|
| | | PUHZ series | PU(H) SUZ MXZ series | |
| Easy maintenance function | <p>Displays information necessary for maintenance. Below information for easy maintenance of air-conditioner can be displayed.</p> <ul style="list-style-type: none"> • Compressor <ul style="list-style-type: none"> • Accumulated operating time • Number of ON/OFF times • Operating current (A) • Outdoor unit <ul style="list-style-type: none"> • Heat exchanger temperature (°C) • Discharge temperature (°C) • Outside air temperature (°C) • Indoor unit <ul style="list-style-type: none"> • Intake air temperature (°C) • Heat exchanger temperature (°C) • Filter operating time (hours) <p>The operation state of inverter models can be monitored using the maintenance stable-operation control (fixed frequency)</p> | ○ | ✕ | 6 |
| Operation data monitor function | Information necessary for maintenance can be displayed on the remote controller. | | | 48 |
| Error code monitor function | Error code is displayed in the service inspection monitor. | ○ | ○ | 44 |
| Contact number display | Displays the contact telephone number to be called when an error occurs. | ○ | ○ | 33 |
| Multi language display | <p>In addition to English, contents can be displayed in 7 other languages.</p> <ul style="list-style-type: none"> • English, German, Spanish, Russian, Italian, Chinese, French, Japanese | ○ | ○ | 12 |
| Temperature display (°C/°F) setting | Enables you to set the unit (°C/°F) in which temperatures are to be displayed. | ○ | ○ | 35 |
| Room temperature display setting | Enables you to set whether to show or hide the indoor (room) temperature. | ○ | ○ | 36 |
| Auto heat/cool display setting | Enables you to set whether to display or hide "COOL"/"HEAT" in auto mode. | ○ | ○ | 37 |
| Weekly schedule timer | <p>Provides a built-in weekly timer that allows you to make on/off and temperature settings.</p> <p>Up to 8 patterns can be set for each day of the week.</p> | ○ | ○ | 23 |
| "Operation limit function setting (Operation lock)" | Lets you disable all the buttons or all the buttons except for the [ON/OFF] button, preventing mischief and incorrect operations. | ○ | ○ | 14 |
| Temperature range limit function | Enables you to establish upper and lower limits for the temperature setting. This prevents overcooling or overheating, thereby contributing to energy saving. | ○ | ○ | 18 |
| Clock function setting | Enables you to set whether to use the clock function. | ○ | ○ | 21 |
| Auto off timer | <p>Stops operation when the preset time elapses following the start of operation.</p> <p>The time can be set from 30 minutes to 4 hours in 30-minute increments.</p> <p>By default, the weekly timer is selected.</p> <p>To switch to the auto off timer, select it using the remote controller's function selection.</p> | ○ | ○ | 26 |
| Simple timer | Enables you to set on/off settings in 1-hour increments within 72 hours. | ○ | ○ | 29 |
| Remote controller main/sub setting | Enables you to set the remote controller as the main or sub. | ○ | ○ | 20 |

III. Appearance

1. Display Section

For purposes of this explanation, all parts of the display are shown as lit. During actual operation, only the relevant items will be lit.

Identifies the current operation
Shows the operating mode, etc.
* Multilanguage display is supported.

“Centrally Controlled” indicator
Indicates that operation of the remote controller has been prohibited by a master controller.

“Timer is Off” indicator
Indicates that the timer is off.

Temperature setting
Shows the target temperature.

Day-of-Week
Shows the current day of the week.

Time/Timer Display
Shows the current time, unless the simple or Auto Off timer is set.
If the simple or Auto Off timer is set, shows the time remaining.

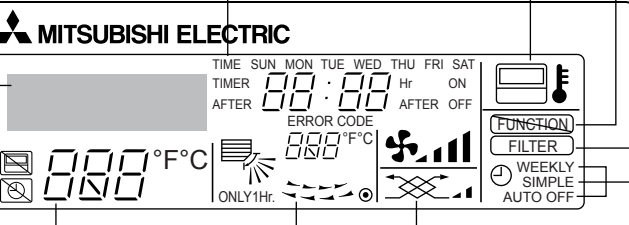

Up/Down Air Direction indicator
The indicator shows the direction of the outgoing airflow.

“One Hour Only” indicator
Displayed if the airflow is set to low and downward during COOL or DRY mode. (Operation varies according to model.)
The indicator goes off after 1 hour, at which time the airflow direction also changes.

Room Temperature display
Shows the room temperature.

Louver display
Indicates the action of the swing louver. Does not appear if the louver is stationary.

(Power On indicator)
Indicates that the power is on.

“Sensor” indication
Displayed when the remote controller sensor is used.

“Locked” indicator
Indicates that remote controller buttons have been locked.

“Clean The Filter” indicator
Comes on when it is time to clean the filter.

Timer indicators
The indicator comes on if the corresponding timer is set.

Fan Speed indicator
Shows the selected fan speed.

Ventilation indicator
Appears when the unit is running in Ventilation mode.

2. Operation Section

Set Temperature buttons



Timer Menu button (Monitor/Set button)

Mode button (Return button)

Set Time buttons
Back Ahead

Timer On/Off button (Set Day button)

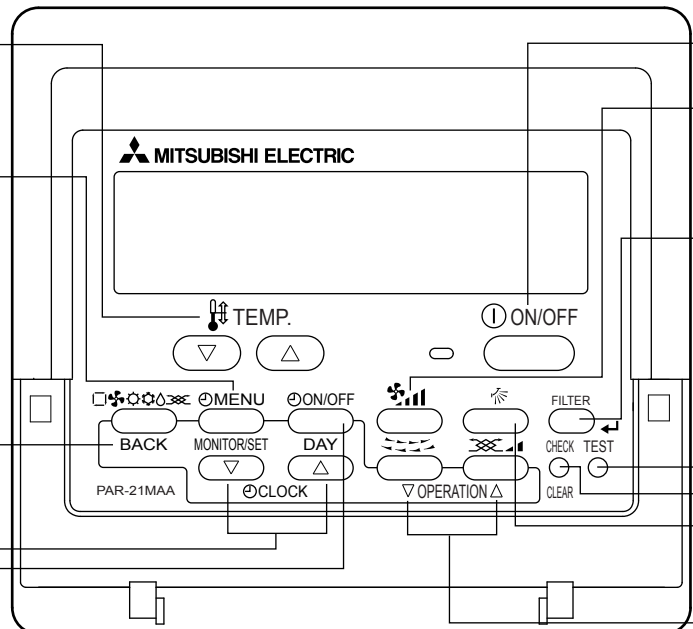
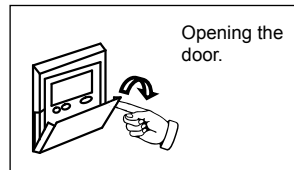

ON/OFF button

Fan Speed button

Filter button (<Enter> button)

Test Run button

Check button (Clear button)

Airflow Up/Down button

Louver button (Operation button)
To preceding operation number.

Ventilation button (Operation button)
To next operation number.

Note:
● If you press a button for a feature that is not installed at the indoor unit, the remote controller will display the “Not Available” message.
If you are using the remote controller to drive multiple indoor units, this message will appear only if the feature is not present at every unit connected.

IV. Easy Maintenance Function (For Mr.SLIM PUAZ series)

- Reduces maintenance work drastically.
 - Enables you to check operation data of the indoor and outdoor units by remote controller.
- Furthermore, use of maintenance stable-operation control that fixes the operating frequency, allows smooth inspection, even for inverter models.

Smooth Maintenance Function

Discharge temperature 64°C

• Conventional inspection work

Easy maintenance information (unit)

| Compressor | Outdoor unit | Indoor unit |
|--|-----------------------------------|-----------------------------------|
| ① Accumulated operating time (×10 hours) | ④ Heat exchanger temperature (°C) | ⑦ Room temperature (°C) |
| ② Number of ON/OFF times (×10 times) | ⑤ Discharge temperature (°C) | ⑧ Heat exchanger temperature (°C) |
| ③ Operating current (A) | ⑥ Outside air temperature (°C) | ⑨ Filter operating time* (Hours) |

* The filter operating time is the time that has elapsed since the filter was reset.

1. Maintenance Mode Operating Method

* If you are going to use the " 2. Guide for Operation Condition ", set the airflow to "High" before activating maintenance mode.

• Switching to maintenance mode

Maintenance mode can be activated either when the air conditioner is operated or stopped. It cannot be activated during test run.

※ Maintenance information can be viewed even if the air conditioner is stopped.

■ Remote controller button information

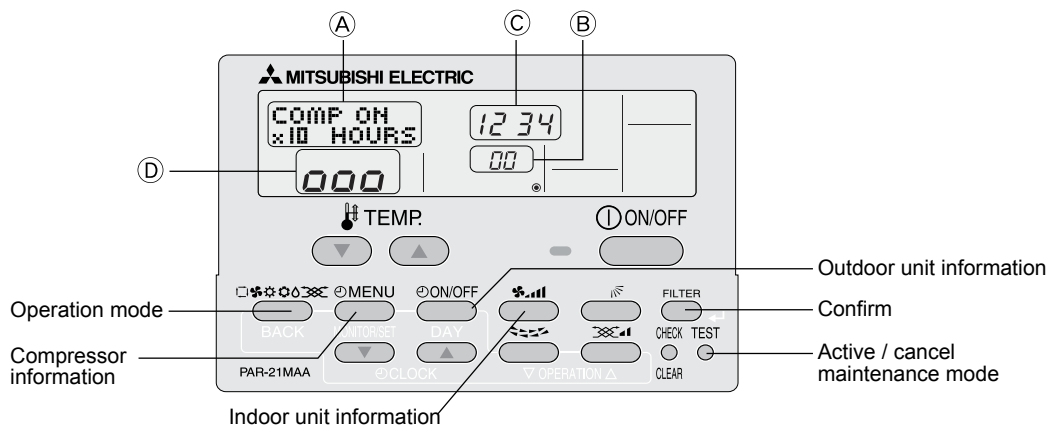

(1) Press the **TEST** button for 3 seconds to switch to maintenance mode.

[Display **A**] MAINTENANCE

If stable operation is unnecessary or if you want to check the data with the air conditioner stopped, skip to step (4).

• Fixed Hz operation

The operating frequency can be fixed to stabilize operation of inverter model. If the air conditioner is currently stopped, start it by this operation.

(2) Press the **MODE** button to select the desired operation mode.

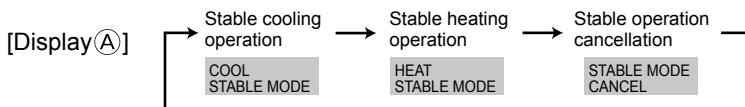

(3) Press the **FILTER** (←) button to confirm the setting.



● **Data measurement**

When the operation is stabilized, measure operation data as explained below.

➔(4) Press the [TEMP] buttons (▽) and (△) to select the desired refrigerant address.



➔(5) Select the type of data to be displayed.

After selecting, go to step (6).

Compressor information

(MENU) button



Outdoor unit information

(ON/OFF) button

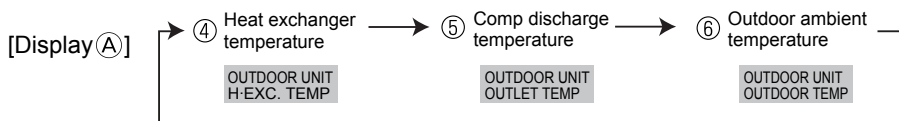

Indoor unit information

(Signal icon) button

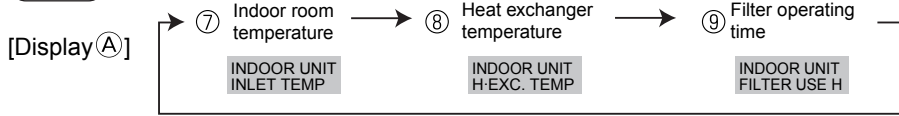

(6) Press the (FILTER) (←) button to confirm the setting.

[Display example for accumulated operating time]

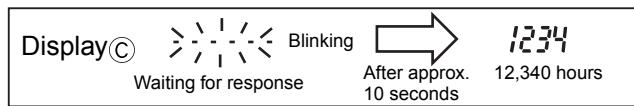

(7) Data is displayed on the display (at (C)).

To check the data for each item, repeat steps (5) to (7).

(8) To cancel maintenance mode, press the (TEST) button for three seconds or press the (ON/OFF) button.

■ **Refrigerant address**

Single refrigerant system

In the case of single refrigerant system, the refrigerant address is "00" and no operation is required.

Simultaneous twin, triple and quad units belong to this category (single refrigerant system).

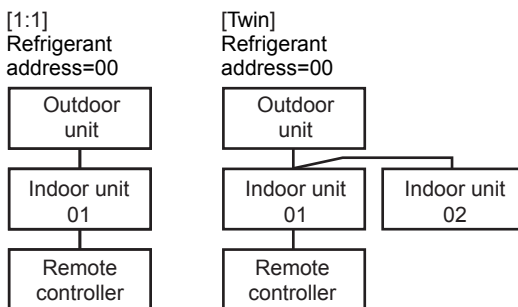

Multi refrigerant system (group control)

Up to 16 refrigerant systems (16 outdoor units) can be connected as a group by one remote controller. To check or set the refrigerant addresses.

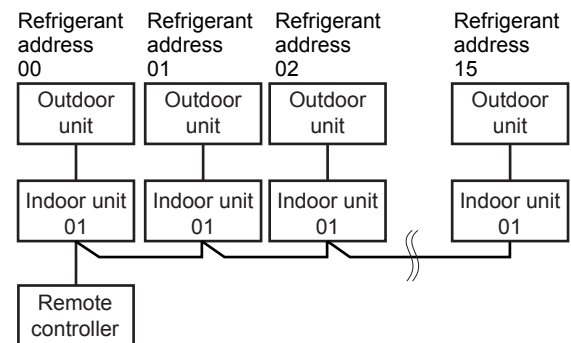

2. Guide for Operation Condition

| | | Inspection item | | Result | |
|-----------------|------------------|--|--------------|-------------------|-------------|
| Power supply | Loose connection | Terminal block | Breaker | Good | Retightened |
| | | | Outdoor Unit | Good | Retightened |
| | | | Indoor Unit | Good | Retightened |
| | | (Insulation resistance) | | MΩ | |
| | (Voltage) | | V | | |
| Compressor | | ① Accumulated operating time | | Time | |
| | | ② Number of ON/OFF times | | Times | |
| | | ③ Current | | A | |
| Outdoor Unit | Temperature | ④ Refrigerant/heat exchanger temperature | COOL °C | HEAT °C | |
| | | ⑤ Refrigerant/discharge temperature | COOL °C | HEAT °C | |
| | | ⑥ Air/outside air temperature | COOL °C | HEAT °C | |
| | | (Air/discharge temperature) | COOL °C | HEAT °C | |
| | Cleanliness | Appearance | Good | Cleaning required | |
| | | Heat exchanger | Good | Cleaning required | |
| Sound/vibration | | None | Present | | |
| Indoor Unit | Temperature | ⑦ Air/Room air temperature | COOL °C | HEAT °C | |
| | | (Air/discharge temperature) | COOL °C | HEAT °C | |
| | | ⑧ Refrigerant/heat exchanger temperature | COOL °C | HEAT °C | |
| | | ⑨ Filter operating time* | | Time | |
| | Cleanliness | Decorative panel | Good | Cleaning required | |
| | | Filter | Good | Cleaning required | |
| | | Fan | Good | Cleaning required | |
| | | Heat exchanger | Good | Cleaning required | |
| | | Sound/vibration | None | Present | |

* The filter operating time is the time that has elapsed since the filter was reset.

| Area | Check item | Judgment | |
|-------------------|--|----------|------|
| | | Cool | Heat |
| Normal | Normal operation state | | |
| Filter inspection | Filter may be clogged. *1 | | |
| Inspection A | Performance has dropped. Detailed inspection is necessary. | | |
| Inspection B | Refrigerant amount is dropping. | | |
| Inspection C | Filter or indoor heat exchanger may be clogged. | | |

* The above judgement is just guide based on Japanese standard conditions.
It may be changed depending on the indoor and outdoor temperature.

*1 If may be judged as "Filter inspection" due to the outdoor and indoor temperature, even though it is not clogged.

Check Points

Enter the temperature differences between ⑤, ④, ⑦ and ⑧ into the graph given below.

Operation state is determined according to the plotted areas on the graph.

For data measurements, set the fan speed to "Hi" before activating maintenance mode.

| Classification | Item | Result | |
|----------------|------------------------|---|-------------------|
| Cool | Inspection | Is "000" displayed stably in Display ④ on the remote controller? | Stable Unstable |
| | Temperature difference | (⑤ Discharge temperature) - (④ Outdoor heat exchanger temperature) (⑦ Indoor room temperature) - (⑧ Indoor heat exchanger temperature) | °C °C |
| Heat | Inspection | Is "000" displayed stably in Display ④ on the remote controller? | Stable Unstable |
| | Temperature difference | (⑤ Discharge temperature) - (⑧ Indoor heat exchanger temperature) (⑧ Indoor heat exchanger temperature) - (⑦ Indoor room temperature) | °C °C |

* Fixed Hz operation may not be possible under the following temperature ranges.

A) In cool mode, outdoor intake air temperature is 40 °C or higher or indoor room temperature is 23 °C or lower

B) In heat mode, outdoor intake air temperature is 20 °C or higher or indoor room temperature is 25 °C or lower

* If the air conditioner is operated at a temperature range other than the ones above but operation is not stabilized after 30 minutes or more have elapsed, carry out inspection.

* In heat mode, the operation state may vary due to frost forming on the outdoor heat exchanger.

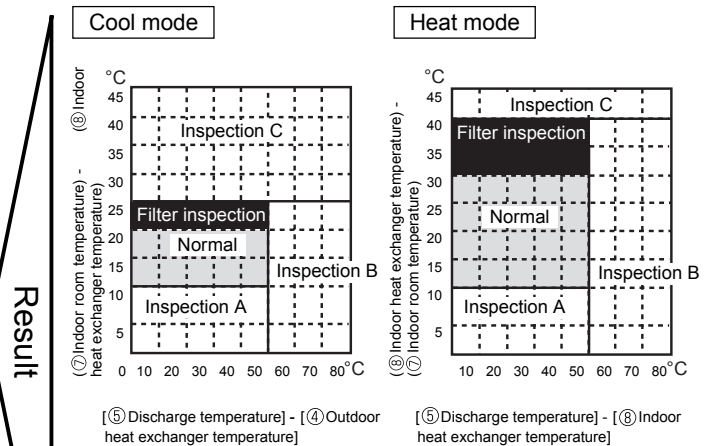

V. How to Select Functions of remote controller

1. Function Items

The setting of the following remote controller functions can be changed using the remote controller function selection mode. Change the setting when needed.

| Item 1 | Item 2 | Item 3 (Setting content) |
|---|--|---|
| 1.Change Language ("CHANGE LANGUAGE") | Language setting to display | • Display in multiple languages is possible. |
| 2.Function limit ("FUNCTION SELECTION") | (1) Operation function limit setting (operation lock) ("LOCKING FUNCTION") | • Setting the range of operation limit (operation lock) |
| | (2) Use of automatic mode setting ("SELECT AUTO MODE") | • Setting the use or non-use of "automatic" operation mode |
| | (3) Temperature range limit setting ("LIMIT TEMP FUNCTION") | • Setting the temperature adjustable range (maximum, minimum) |
| 3.Mode selection ("MODE SELECTION") | (1) Remote controller main/sub setting ("CONTROLLER MAIN/SUB") | • Selecting main or sub remote controller * When 2 remote controllers are connected to 1 group, 1 controller must be set to sub. |
| | (2) Use of clock setting ("CLOCK") | • Setting the use or non-use of clock function |
| | (3) Timer function setting ("WEEKLY TIMER") | • Setting the timer type |
| | (4) Contact number setting for error situation ("CALL.") | • Contact number display in case of error • Setting the telephone number |
| 4.Display change ("DISP MODE SETTING") | (1) Temperature display °C/°F setting ("TEMP MODE °C/°F") | • Setting the temperature unit (°C or °F) to display |
| | (2) Room temperature display setting ("ROOM TEMP DISP SELECT") | • Setting the use or non-use of the display of indoor (suction) air temperature |
| | (3) Automatic cooling/heating display setting ("AUTO MODE DISP C/H") | • Setting the use or non-use of the display of "Cooling" or "Heating" display during operation with automatic mode |

[Function selection flowchart] Refer to next page.

[1] Stop the air conditioner to start remote controller function selection mode. → [2] Select from item1. → [3] Select from item2. → [4] Make the setting. (Details are specified in item3) → [5] Setting completed. → [6] Change the display to the normal one. (End)

[Detailed setting]

[4] -1. CHANGE LANGUAGE setting

The language that appears on the dot display can be selected.

- ① Japanese (JP), ② English (GB), ③ German (D), ④ Spanish (E),
- ⑤ Russian (RU), ⑥ Italian (I), ⑦ Chinese (CH), ⑧ French (F)

[4] -2. Function limit (FUNCTION SELECTION)

(1) Operation function limit setting (operation lock)(LOCKING FUNCTION)

- ① no1 : Operation lock setting is made on all buttons other than the [ON/OFF] button.
 - ② no2 : Operation lock setting is made on all buttons.
 - ③ OFF (Initial setting value) : Operation lock setting is not made
- * To make the operation lock setting valid on the normal screen, it is necessary to press buttons (Press and hold down the [FILTER] and [ON/OFF] buttons at the same time for 2 seconds.) on the normal screen after the above setting is made.

(2) Use of automatic mode setting

When the remote controller is connected to the unit that has automatic operation mode, the following settings can be made.

- ① ON (Initial setting value) : The automatic mode is displayed when the operation mode is selected.
- ② OFF : The automatic mode is not displayed when the operation mode is selected.

(3) Temperature range limit setting (LIMIT TEMP FUNCTION)

After this setting is made, the temperature can be changed within the set range.

- ① LIMIT TEMP COOL MODE :
The temperature range can be changed on cooling/dry mode.
- ② LIMIT TEMP HEAT MODE :
The temperature range can be changed on heating mode.
- ③ LIMIT TEMP AUTO MODE :
The temperature range can be changed on automatic mode.
- ④ OFF (initial setting) : The temperature range limit is not active.

* When the setting, other than OFF, is made, the temperature range limit setting on cooling, heating and automatic mode is made at the same time. However the range cannot be limited when the set temperature range has not changed.

- To increase or decrease the temperature, press the [TEMP (▽) or (△)] button.
- To switch the upper limit setting and the lower limit setting, press the [TEMP (▽) or (△)] button. The selected setting will blink and the temperature can be set.
- Settable range
Cooling/Dry mode : Lower limit: 19°C ~ 30°C , 67°F~87°F
Upper limit: 30°C ~ 19°C , 87°F~67°F
Heating mode : Lower limit: 17°C ~ 28°C , 63°F~83°F
Upper limit: 28°C ~ 17°C , 83°F~63°F
Automatic mode : Lower limit: 19°C ~ 28°C , 67°F~83°F
Upper limit: 28°C ~ 19°C , 83°F~67°F

[4] -3. Mode selection setting (MODE SELECTION)

(1) Remote controller main/sub setting

- ① Main : The controller will be the main controller.
- ② Sub : The controller will be the sub controller.

(2) CLOCK setting

- ① ON : The clock function can be used.
- ② OFF : The clock function cannot be used.

(3) Timer function setting

- ① WEEKLY TIMER (initial setting):
The weekly timer can be used.
- ② AUTO OFF TIMER: The auto off timer can be used.
- ③ SIMPLE TIMER : The simple timer can be used.
- ④ TIMER MODE OFF: The timer mode cannot be used.
- * When CLOCK setting is OFF, the "WEEKLY TIMER" cannot be used.

(4) Contact number setting for error situation

- ① CALL OFF : The set contact numbers are not displayed in case of error.
- ② CALL **** * : The set contact numbers are displayed in case of error.
- ③ CALL_ : The contact number can be set when the display is as shown on the left.

- Setting the contact numbers

To set the contact numbers, follow the following procedures.

Move the blinking cursor to set numbers. Press the [TEMP (▽) and (△)] button to move the cursor to the right (left). Press the [CLOCK (▽) and (△)] button to set the numbers.

[4] -4. Display change setting (DISP MODE SETTING)

(1) Temperature display °C / °F setting

- ① °C : The temperature unit °C is used.
- ② °F : The temperature unit °F is used.

(2) Room temperature display setting (ROOM TEMP DISP SELECTION)

- ① ON : The room temperature is displayed.
- ② OFF : The room temperature is not displayed.

(3) Automatic cooling/heating display setting (AUTO MODE DISP C/H)

- ① ON : One of "Automatic cooling" and "Automatic heating" is displayed under the automatic mode is running.
- ② OFF : Only "Automatic" is displayed under the automatic mode.

2. Flowchart of Function Setting

Setting language (English)

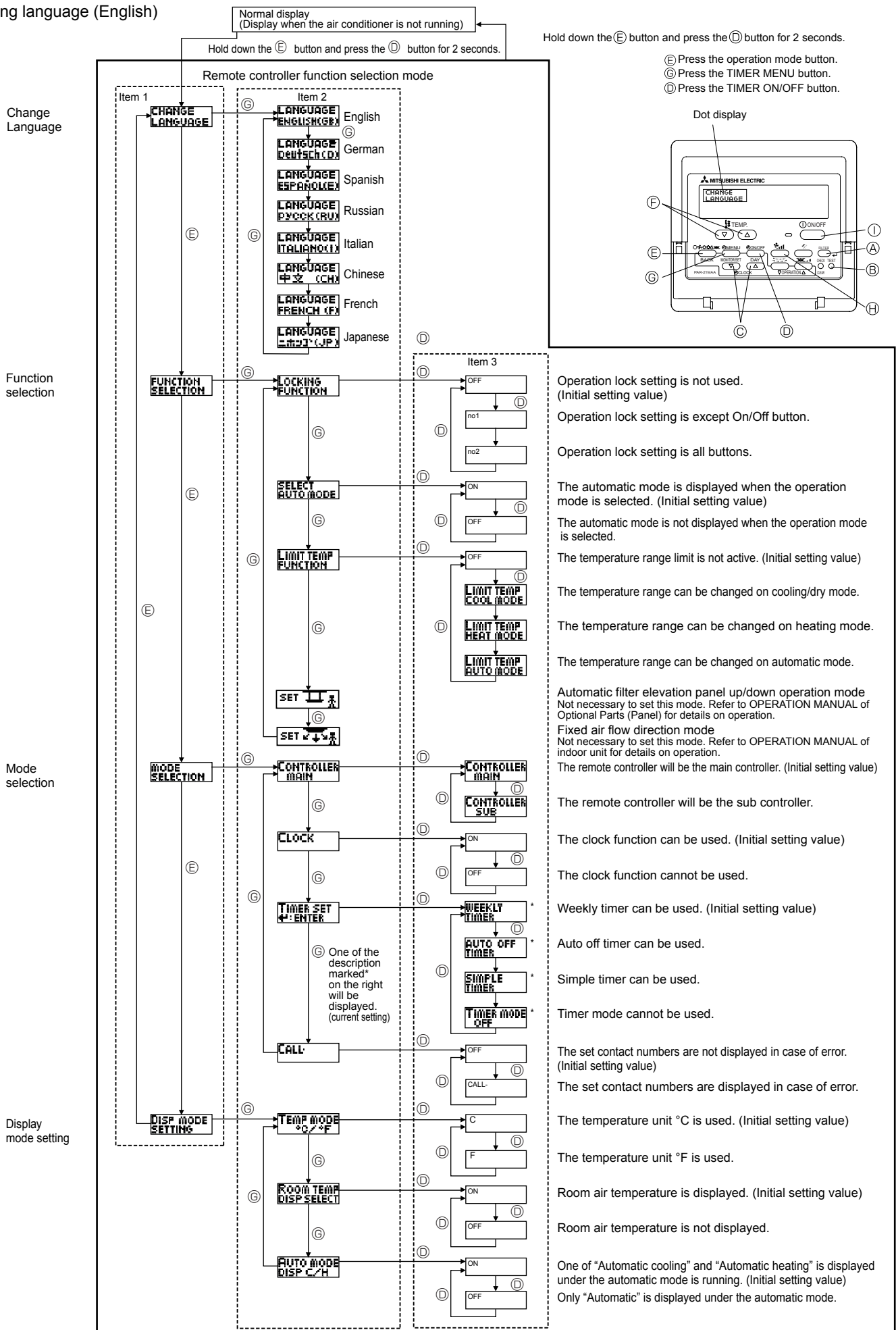

3. Screen Structure for Function Setting

Description of each screen

- Function selection of remote controller : Used to set the timer function and operation limit function, etc.
- Set day time : Used to set the current day of the week and time.
- Standard control screen : Used to set the air conditioner's operating state.
- Timer monitor screen : Used to display the current settings of the timers (weekly, simple, auto off).
- Timer set up screen : Used to set the timers (weekly, simple, auto off).

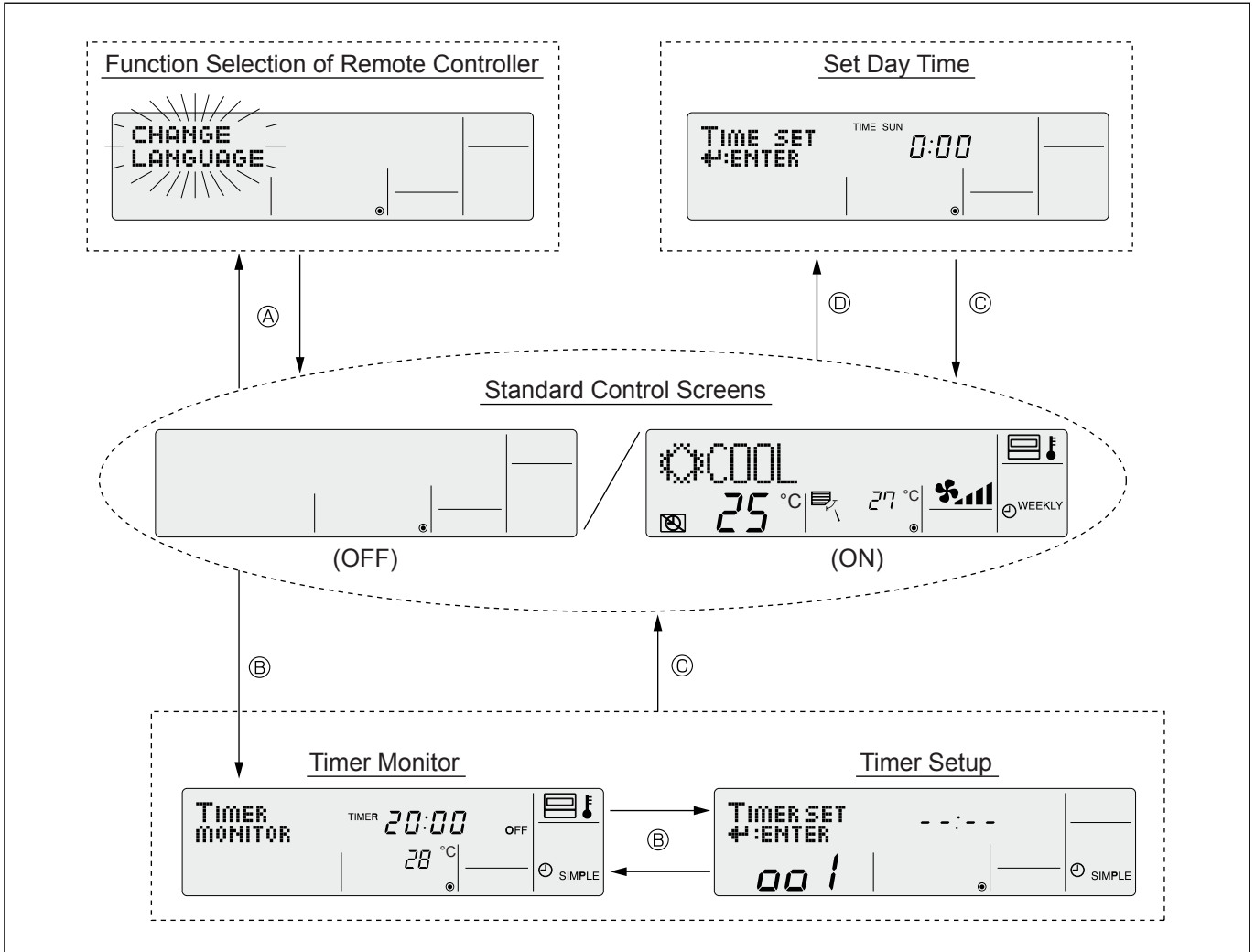

How to change the screen display

- Ⓐ: Press the [ON/OFF] button for two seconds while holding down the [MODE] button.
- Ⓑ: Press the [MENU] button.
- Ⓒ: Press the [MODE] (BACK) button.
- Ⓓ: Press the [CLOCK] buttons (▽ and △).

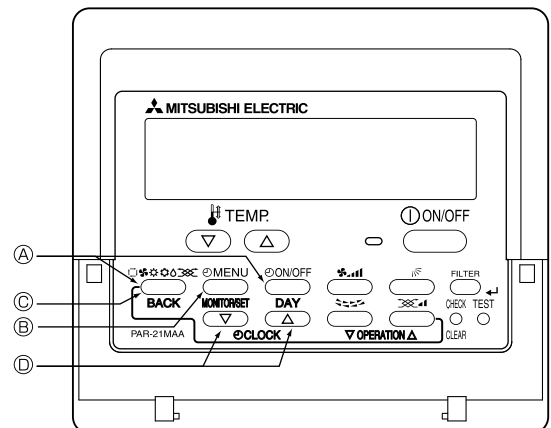

4. Function Setting Mode

4.1 Change Language

The language that appears on the dot display can be selected.

The following languages can be selected.

- ①English (GB) ②German (D) ③Spanish (E) ④Russian (RU)
- ⑤Italian (I) ⑥Chinese (CH) ⑦French (F) ⑧Japanese (JP)

Changing the Display Language

■ Display example

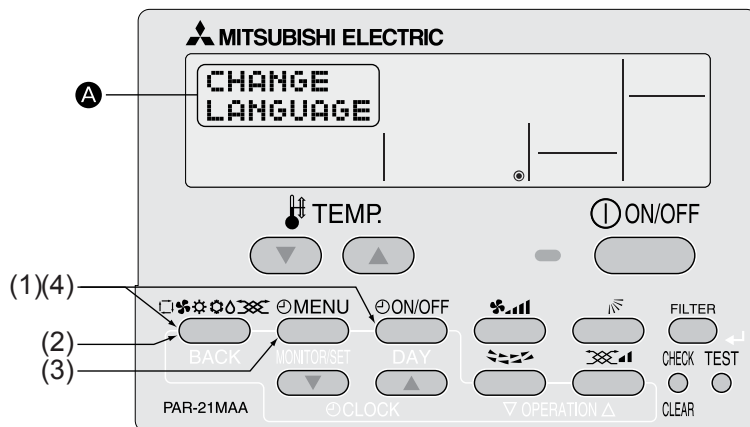

(1) While pressing the **MODE** button, press the **ON/OFF** button for 2 seconds to activate the remote controller's function selection mode.

(2) Press the **MODE** button until **CHANGE LANGUAGE** appears on the screen (at **A**).



(3) Press the **MENU** button to select the desired display language.

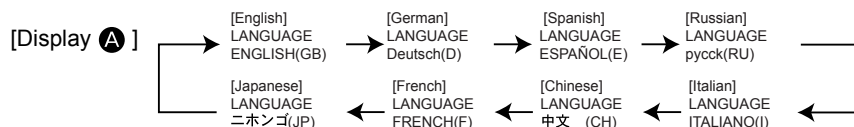

(4) While pressing the **MODE** button, press the **ON/OFF** button for two seconds to return to normal mode. Setting is now complete.

| | | | | | | | | |
|--------------------------------|---------|------|---------|--------|---------|-------|----------|-------|
| Display example (Cool mode) | English | COOL | German | Kühlen | Spanish | FRÍO | Russian | Холод |
| | Italian | COOL | Chinese | 制冷 | French | FROID | Japanese | 冷房 |

Multi Language Display

[Dot display table]

| Selecting language | English | German | Spanish | Russian | Italian | Chinese | French | Japanese | |
|-------------------------|------------------------|-----------------------|----------------------|----------------------|---------------------------|--------------|------------------------|---------------|-----|
| Waiting for start-up | PLEASE WAIT | ← | ← | ← | ← | ← | ← | ← | |
| Operation mode | Cool | COOL | Kühlen | FRÍO | Холод | COOL | 制冷 | FROID | 冷房 |
| | Dry | DRY | Trocknen | DESHUMIDIFICACIÓN | Сушка | DRY | 除湿 | DESHU | ドライ |
| | Heat | HEAT | Heizen | CALOR | Тепло | HEAT | 制热 | CHAUD | 暖房 |
| | Auto | AUTO | AUTO | AUTOMÁTICO | Авто | AUTO | 自动 | AUTO | 自動 |
| | Auto(Cool) | COOL | Kühlen | FRÍO | Холод | COOL | 制冷 | FROID | 冷房 |
| | Auto(Heat) | HEAT | Heizen | CALOR | Тепло | HEAT | 制热 | CHAUD | 暖房 |
| | Fan | FAN | Lüfter | VENTILACIÓN | ВЕНТ | VENTILAZIONE | 送风 | VENTILATION | 送風 |
| | Ventilation | VENTILATION | Gellüftung | VENTILACIÓN | ВЕНТИЛЯЦИЯ | ARIA ESTERNA | 换气 | VENTILATION | 換気 |
| | Stand by (Hot adjust) | STAND BY | STAND BY | CALENTANDO | ОБОГРЕВ: ПАУЗА | STAND BY | 准备中 | PRE CHAUFFAGE | 準備中 |
| Defrost | DEFROST | Alttauen | DESCONGE-LACIÓN | ОТТАИВАНИЕ | SRINA MENTO | 除霜中 | DEGIVRAGE | 霜取中 | |
| Set temperature | SET TEMP | TEMP einstellen | TEMP CONSIGNA | ЦЕЛЕВАЯ ТЕМПЕРАТУРА | IMPOSTAZIONE TEMPERATURA | 设定温度 | REGLAGE TEMPERATURE | 設定温度 | |
| Fan speed | FAN SPEED | Lüftergeschwindigkeit | VELOCIDAD VENTILADOR | СКОРОСТЬ ВЕНТИЛЯТОРА | VELOCITA' VENTILATORE | 风速 | VITESSE DE VENTILATION | 風速 | |
| Not use button | NOT AVAILABLE | Nicht verfügbar | NO DISPONIBLE | НЕ ДОСТУПНО | NON DISPONIBILE | 无效按钮 | NON DISPONIBLE | 無効ボタン | |
| Check (Error) | CHECK | Prüfen | COMPROBAR | ПРОВЕРКА | CHECK | 检查 | CONTROLE | 点検 | |
| Test run | TEST RUN | Testbetrieb | TEST FUNCIONAMIENTO | ТЕСТОВЫЙ ЗАПУСК | TEST RUN | 试运行 | TEST | 試運転 | |
| Self check | SELF CHECK | Selbst-diagnose | AUTO REVISIÓN | САМОДИАГНОСТИКА | SELF CHECK | 自我诊断 | AUTO CONTROLE | 自己診断 | |
| Unit function selection | FUNCTION SELECTION | Funktion auswählen | SELECCIÓN DE FUNCIÓN | ВЫБОР ФУНКЦИИ | SELEZIONE FUNZIONI | 功能选择 | SELECTION FONCTIONS | キョウ選択 | |
| Setting of ventilation | SETTING OF VENTILATION | Lüfterstufen wählen | CONFIG. VENTILACIÓN | НАСТРОЙКА ВЕНТУСТАИ. | IMPOSTAZIONE ARIA ESTERNA | 换气设定 | SELECTION VENTILATION | 換気設定 | |

| Selecting language | English | German | Spanish | Russian | Italian | Chinese | French | Japanese |
|---|--------------------------------|---|---------------------------------------|----------------------------------|-------------------------------|--------------------------|------------------------------------|------------------------------|
| CHANGE LANGUAGE | CHANGE LANGUAGE | ← | ← | ← | ← | ← | ← | ← |
| Function selection | FUNCTION SELECTION | Funktion auswählen | SELECCIÓN DE FUNCIONES | ВЫБОР ФУНКЦИИ | SELEZIONE FUNZIONI | 功能限制 | SELECTION FONCTIONS | キョウ制限 |
| Operation function limit setting | LOCKING FUNCTION | Sperr-Funktion | FUNCIÓN BLOQUEADA | ФУНКЦИЯ БЛОКИРОВКИ | BLOCCO FUNZIONI | 操作限制 | BLOCCAGE FONCTIONS | 操作ロック |
| Use of automatic mode setting | SELECT AUTO MODE | Auswahl auto betrieb | SELECCIÓN MODO AUTO | ВЫБОР РЕЖИМА АВТО | SELEZIONE MODO AUTO | 自动模式 | SELECTION DU MODO AUTO | 自動モード |
| Temperature range limit setting | LIMIT TEMP FUNCTION | Limit Temp Funktion | LIMIT TEMP CONSIGNA | ОГРАНИЧЕННЫЕ УСТ.ТЕМПЕРАТ | LIMITAZIONE TEMPERATURA | 温度限制 | LIMITATION TEMPERATURE | 温度制限 |
| Limit temperature cooling/day mode | LIMIT TEMP COOL MODE | Limit Kühl Temp | LIMIT TEMP MODO FRIO | ОГРАНИЧЕНО ОХЛАЖДЕНИЕ | LIMITAZIONE MODO COOL | 制冷范围 | LIMITE TEMP MODO FROID | 制冷房 |
| Limit temperature heating mode | LIMIT TEMP HEAT MODE | Limit Heiz Temp | LIMIT TEMP MODO CALOR | ОГРАНИЧЕН ОБОГРЕВ | LIMITAZIONE MODO HEAT | 制热范围 | LIMITE TEMP MODO CHAUD | 制热房 |
| Limit temperature auto mode | LIMIT TEMP AUTO MODE | Limit Auto Temp | LIMIT TEMP MODO AUTO | ОГРАНИЧЕН РЕЖИМ АВТО | LIMITAZIONE MODO AUTO | 自动范围 | LIMITE TEMP MODO AUTO | 制自动 |
| Mode selection | MODE SELECTION | Betriebsart wählen | SELECCIÓN DE MODO | ВЫБОР РЕЖИМА | SELEZIONE MODO | 基本模式 | SELECTION DU MODO | 基本キョウ |
| Remote controller setting MAIN | CONTROLLER MAIN | Hauptcontroller | CONTROL PRINCIPAL | ОСНОВНОЙ ПУЛТ | CONTROLLO MAIN | 遥控主 | TELCOMMANDE MAITRE | リモコ主従 |
| Remote controller setting SUB | CONTROLLER SUB | Nebencontroller | CONTROL SECUNDARIO | ДОПОЛНИТЕЛЬНЫЙ ПУЛТ | CONTROLLO SUB | 遥控辅 | TELCOMMANDE ESCLAVE | リモコ主従 |
| Use of clock setting | CLOCK | Uhr | RELOJ | Часы | OROLOGIO | 时钟 | AFFICHAGE HORLOGE | 時計 ヨウウ |
| Setting the day of the week and time | TIME SET \leftarrow : ENTER | Uhr stellen \leftarrow : einstellen | CONFIG RELOJ \leftarrow : CONFIG | Часы: УСТ. \leftarrow : ВВОД | OROLOGIO \leftarrow : ENTER | 时间 \leftarrow : ENTER | HORLOGE \leftarrow : ENTRER | トケイセッテイ \leftarrow : カクテイ |
| Timer set | TIMER SET \leftarrow : ENTER | Zeitschaltuhr \leftarrow : einstellen | TEMPORIZA - DOR \leftarrow : CONFIG | ТАЙМЕР: УСТ. \leftarrow : ВВОД | TIMER \leftarrow : ENTER | 定时器 \leftarrow : ENTER | PROG HORAIRE \leftarrow : ENTRER | タイマーセッテイ \leftarrow : カクテイ |
| Timer monitor | TIMER MONITOR | Uhrzeit Anzeige | VISUALIZAR TEMPORIZAD. | ПРОСМОТР ТАЙМЕРА | VISUALIZ TIMER | 定时器状态 | AFFICHAGE PROG HORAIRE | タイマーモニター |
| Weekly timer | WEEKLY TIMER | Wochenzeit schalt Uhr | TEMPORIZA - DOR SEMANAL | НЕДЕЛЬНЫЙ ТАЙМЕР | TIMER SETTIMANALE | 每周定时器 | PROG HEBDO MADAIRE | タイマー週間 |
| Timer mode off | TIMER MODE OFF | Zeitschaltuhr AUS | TEMPORIZA - DOR APAGADO | ТАЙМЕР ВЫКЛ. | TIMER OFF | 定时器无效 | PROG HORAIRE INACTIF | タイマー無効 |
| Auto off timer | AUTO OFF TIMER | Auto Zeit funktion AUS | APAGADO AUTOMÁTICO | АВТООТКЛЮЧ. ПО ТАЙМЕРУ | AUTO OFF TIMER | 解除定时 | PROG HORAIRE ARRET AUTO | タイマーオフホウジ |
| Simple timer | SIMPLE TIMER | Einfache Zeitfunktion | TEMPORIZA - DOR SIMPLE | ПРОСТЫЙ ТАЙМЕР | TIMER SEMPLIFICATO | 简易定时器 | PROG HORAIRE SIMPLIFE | タイマーカンイ |
| Contact number setting of error situation | CALL | ← | ← | ← | ← | ← | ← | ← |
| Display change | DISP MODE SETTING | Anzeige Betriebsart | MOSTRAR MODO | НАСТРОЙКА ИЛИ РЕЖИМА | IMPOSTAZIONE MODO DISPLAY | 转换表示 | AFFICHAGE SOUS MENU | 表示切替 |
| Temperature display °C/°F setting | TEMP MODE °C/°F | Wechsel °C/°F | TEMP GRADOS °C/°F | ЕДИН.ТЕМП. °C/°F | TEMPERATURA °C/°F | 温度 °C/°F | TEMPERATURE °C/°F | 温度 °C/°F |
| Room air temperature display setting | ROOM TEMP DISP SELECT | Raum Temp seiwählen | MOSTRAR TEMP. | ПОКАЗЫВАТЬ ТЕМП.В КОМН. | TEMPERATURA AMBIENTE | 吸入温度 | TEMPERATURE AMBIANTE | スィコモニョウ |
| Automatic cooling/heating display setting | AUTO MODE DISP C/H | Auto Betrieb C/H | MOSTRAR F/C EN AUTO | Инд. Т/Х в режиме АВТО | AUTO C/H | 自动力表示 | AFFICHAGE AUTO F/C | 自動力表示 |

4.2 Function Setting

4.2.1 Operation Lock (Operation Function Limit Setting)

The following settings can be made.

- ①no1 :All buttons except for the [ON/OFF] button are locked.
- ②no2 :All buttons are locked.
- ③OFF (default) :No buttons are locked.

* To activate this operation lock function on the normal screen, hold down the **ON/OFF** button for 2 seconds while holding down the **FILTER** (\leftarrow) button.

How to Lock the Buttons

■ Display example

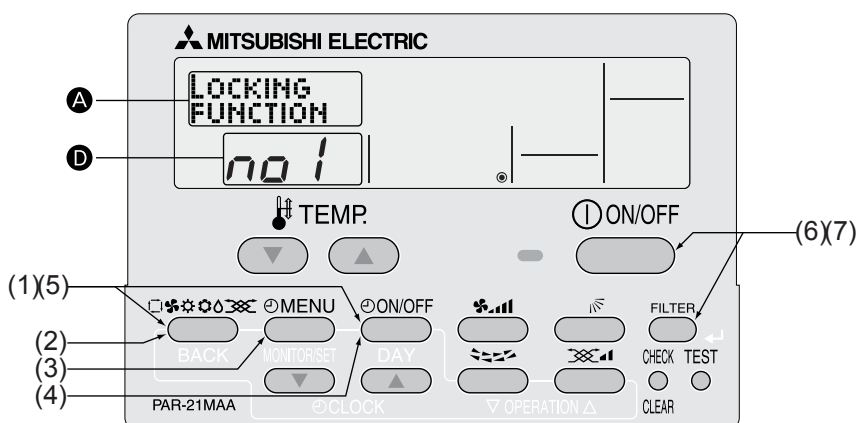

(1) While pressing the **MODE** button, press the **ON/OFF** button for 2 seconds to activate the remote controller's function selection mode.

(2) Press the **MODE** button to select **FUNCTION SELECTION** on the screen (at **A**).



(3) Press the **MENU** button until "LOCKING FUNCTION" appears on the screen (at **A**).

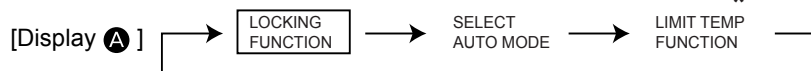

* Displays the mode that is set in "Temperature Range Limit Setting".

(4) Press the **ON/OFF** button until the desired lock mode appears on the screen (at **D**).

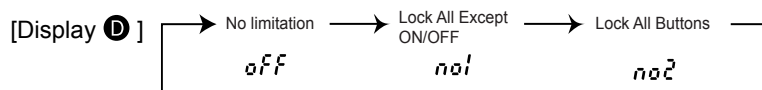

(5) While pressing the **MODE** button, press the **ON/OFF** button for 2 seconds to return to normal mode. Setting is now complete.

Completing steps (1) to (5) allows use of the operation lock function.
To enable the lock function, carry out the following steps.

Enabling the Lock Function

(6) While pressing the **FILTER** () button, press the **ON/OFF** () button for 2 seconds to enable the operation lock function.



FUNCTION appears on the screen (at **E**).

* If a locked button is pressed while the operation lock function is in use, **FUNCTION** will blink on the screen (at **E**).

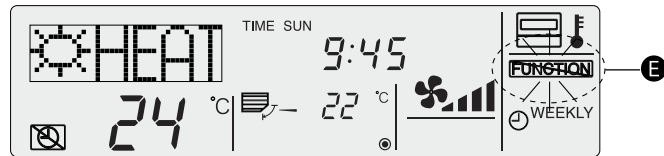
■ Display example when operation lock function is in use



How to Unlock the Buttons

(7) While pressing the **FILTER** () button, press the **ON/OFF** () button for 2 seconds.

FUNCTION disappears from the screen (at **E**).

■ Display example when the operation lock function is not in use

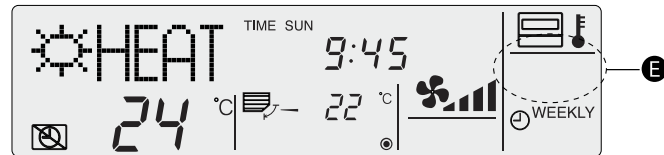

4.2.2 Auto Mode Setting

The following settings can be made.

① ON (default) : Auto mode is displayed when selecting an operation mode only if the unit to be connected supports the auto mode.

However, this does not apply if the unit to be connected does not support the auto mode.

Operation mode can be switched :



② OFF : Even if the unit supports the auto mode, auto mode is not displayed when selecting an operation mode.

Operation mode can be switched :

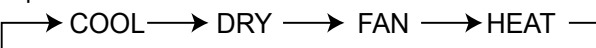

How to Set Auto Mode

■ Display example

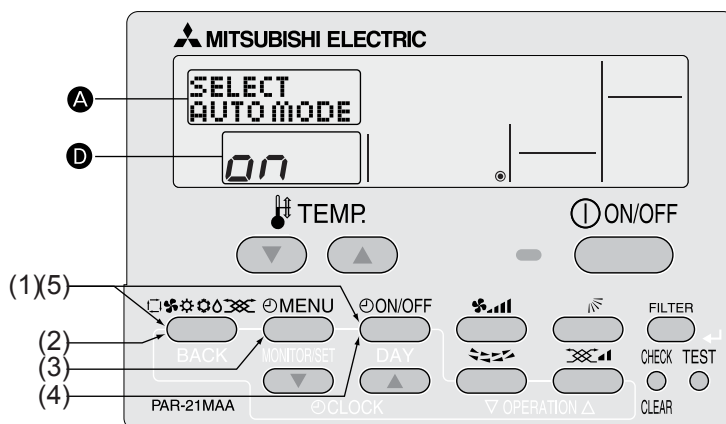

(1) While pressing the **MODE** button, press the **ON/OFF** button for 2 seconds to activate the remote controller's function selection mode.

(2) Press the **MODE** button to select **FUNCTION SELECTION** on the screen (at **A**).



(3) Press the **MENU** button so that **SELECT AUTO MODE** appears on the screen (at **A**).

* The current setting is displayed.

(4) Press the **ON/OFF** button to select whether auto mode is to be used (on) or not (off).



(5) While pressing the **MODE** button, press the **ON/OFF** button for 2 seconds to return to normal mode. Setting is now complete.

* If you press the **ON/OFF** button before the **MODE** button, the settings you have made will be cancelled.

● **Screen display when auto mode is set to ON**

(1) Press the **ON/OFF** button.

The ON lamp lights up and operating contents are displayed on the LCD.

(2) Press the **MODE** button.

Each time the **MODE** button is pressed, the operation mode switches from one to another. "AUTO" is also displayed.



*1: If the remote controller is connected with the unit for cool operation only, "AUTO" and "HEAT" will not be displayed, nor will it be possible to select them.

■ **Display example when auto mode is set to ON**

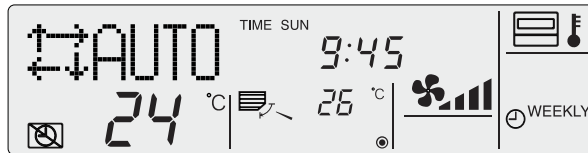

If AUTO MODE DISP C/H is ON (see 4.4.3), it takes about 10 seconds before the display is switched from one mode to another.



● **Screen display when auto mode is set to OFF**

(1) Press the **ON/OFF** button.

The ON lamp lights up and operating contents are displayed on the LCD.

(2) Press the **MODE** button.

Each time the **MODE** button is pressed, the operation mode switches from one to another, but "AUTO" is not displayed.

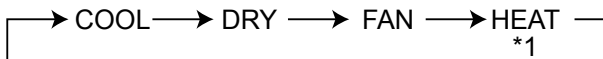

*1: If the remote controller is connected with the unit for cool operation only, "HEAT" will not be displayed.

4.2.3 Temperature Range Limit Setting

The temperature setting range can be limited.
It can be limited for each mode.

- ① Cool mode : The temperature setting range for cool/dry mode can be changed.
- ② Heat mode : The temperature setting range for heat mode can be changed.
- ③ Auto mode : The temperature setting range for auto mode can be changed.
- ④ OFF (default) : The temperature setting range is not limited.

* When a mode other than OFF mode is set, temperature setting range limit setting for cool, heat and auto modes will be made simultaneously.
However, limit setting will not be made unless the range has been changed.

| | Setting range | | Standard setting |
|---------------|---------------|---------------|------------------|
| COOL·DRY Mode | Lower limit | 19 °C – 30 °C | 19 °C – 30 °C |
| | Upper limit | 30 °C – 19 °C | |
| HEAT Mode | Lower limit | 17 °C – 28 °C | 17 °C – 28 °C |
| | Upper limit | 28 °C – 17 °C | |
| AUTO Mode | Lower limit | 19 °C – 28 °C | 19 °C – 28 °C |
| | Upper limit | 28 °C – 19 °C | |

* Temperatures can be set within the range of “upper limit ≥ ” “lower limit”.

Limiting the Temperature Range

■ Display example

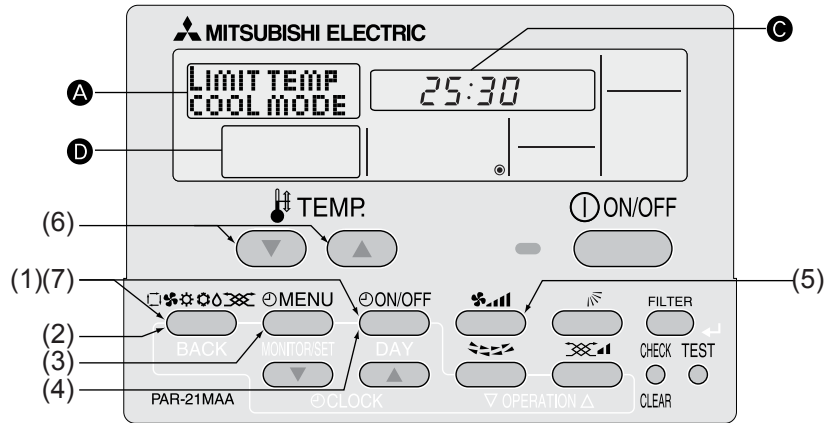

(1) While pressing the **MODE** button, press the **ON/OFF** button for 2 seconds to activate the remote controller's function selection mode.

(2) Press the **MODE** button to select **FUNCTION SELECTION** on the screen (at **A**).

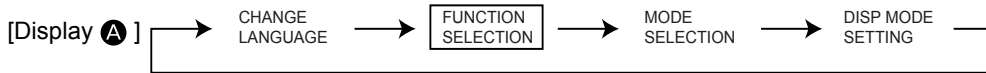

(3) Press the **MENU** button to select **LIMIT TEMP FUNCTION** on the screen (at **A**).

* If a setting change was made previously, the mode that was set (one of the modes shown in step (4)) will be displayed.

(4) Press the **ON/OFF** button to select the mode for which temperature range limit setting is to be made.

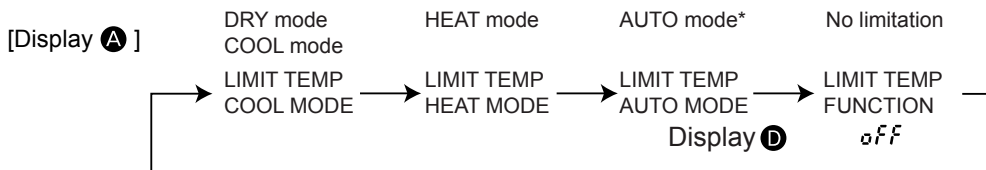

* No operation modes will be displayed if auto mode has been set to OFF.

(5) Press the button to select lower limit or upper limit.

Lower limit blinks. Upper limit blinks.

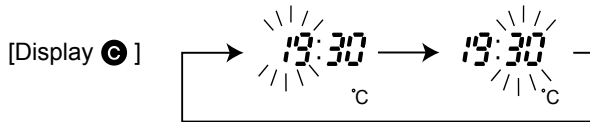

(6) Press the [TEMP] buttons () and () to set the desired temperature setting range.

[Setting example for lower limit]

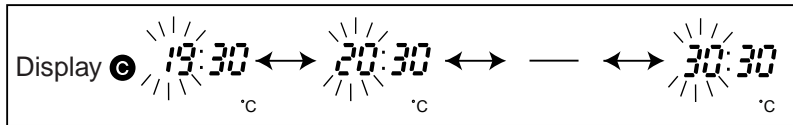

(7) While pressing the **MODE** button, press the button for 2 seconds to return to normal mode. Setting is now complete.

* If you press the button before the **MODE** button, the settings you have made will be cancelled.

* If an attempt is made to set a temperature outside the range when the temperature range limit function is in use, "LIMIT TEMP FUNCTION" will blink.

■ Display example when the temperature range limit function is in use

If employees tend to lower the temperature excessively in the office without permission, set the temperature setting range for cool/dry mode to 25 °C - 30 °C.

Setting

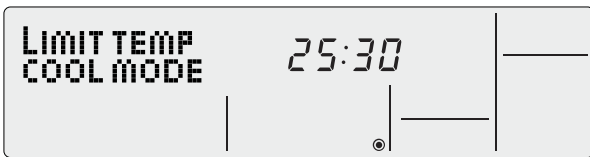

Even if someone who feels hot tries to press remote the controller's buttons to lower the temperature below 24 °C, or lower...

LIMIT TEMP FUNCTION blinks and the command is not accepted.

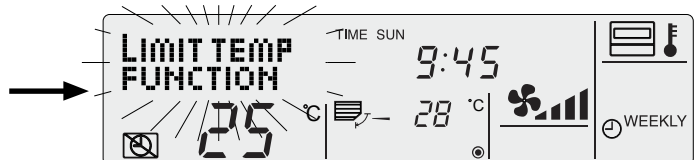
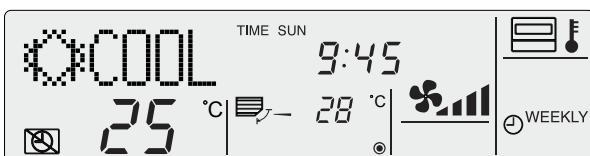

4.3 Basic Functions Setting

4.3.1 Remote Controller Main/Sub Setting

When using 2 remote controllers, they must be designated as the main and sub remote controllers.

The following settings can be made.

①MAIN (default) : The remote controller is set as the main controller.

②SUB : The remote controller is set as the sub controller.

To Change the Main/Sub Setting

■ Display example

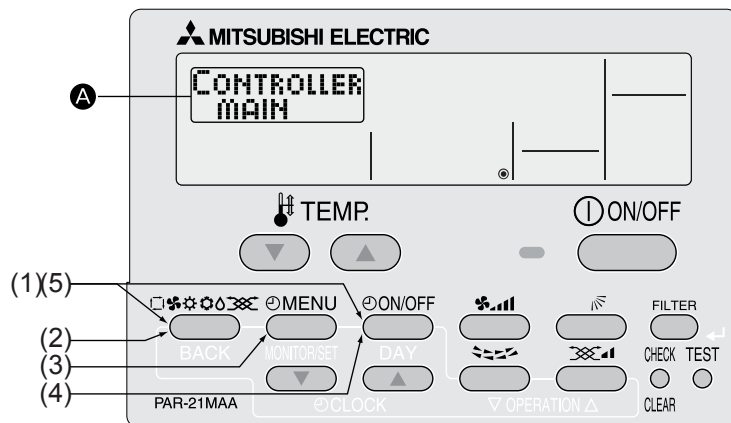

(1) While pressing the **MODE** button, press the **ON/OFF** button for 2 seconds to activate the remote controller's function selection mode.

(2) Press the **MODE** button until **MODE SELECTION** appears on the screen (at **A**).



(3) Press the **MENU** button to select "CONTROLLER" on the screen (at **A**).

(4) Press the **ON/OFF** button to select "CONTROLLER MAIN" or "CONTROLLER SUB" on the screen (at **A**).

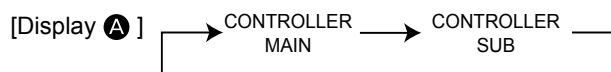

(5) While pressing the **MODE** button, press the **ON/OFF** button for 2 seconds to return to normal mode.

4.3.2 Timer function setting (Weekly timer/Auto off timer/Simple timer)

The following settings can be made.

- ① Weekly Timer (default) : The weekly timer can be used.
 - ② Auto Off Timer : The auto off timer can be used.
 - ③ Simple Timer : The simple timer can be used.
 - ④ Timer Mode Off : Timer mode cannot be used.
- * If the clock function is disabled (OFF), "Weekly Timer" cannot be selected.

■ Clock function setting

The following settings can be made.

- ① ON (default) : The clock function can be used.
 - ② OFF : The clock function cannot be used.
- * If "OFF" is selected to disable the clock function, the weekly timer cannot be used to make day of the week/time settings.
To use the weekly timer to set the day of the week and time, the clock function must be set to "ON" (default).

To Use the Clock

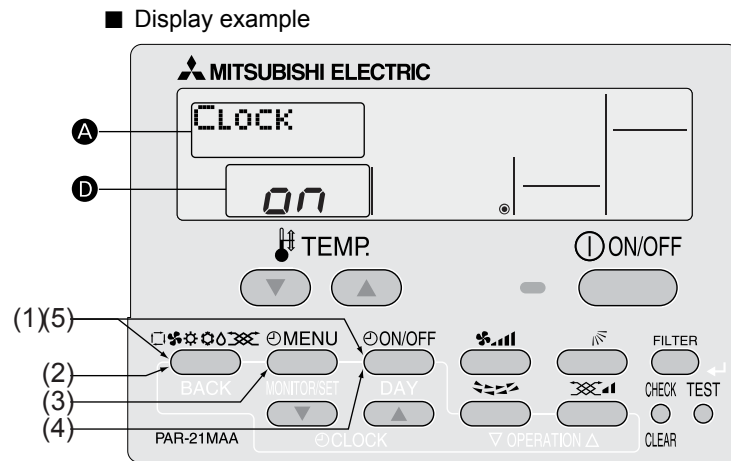

(1) While pressing the **MODE** button, press the **ON/OFF** button for 2 seconds to activate the remote controller's function selection mode.

(2) Press the **MODE** button until **MODE SELECTION** appears on the screen (at **A**)



(3) Press the **MENU** button to select "CLOCK" on the screen (at **A**).

(4) Press the **ON/OFF** button so that "ON" appears on the screen (at **B**).

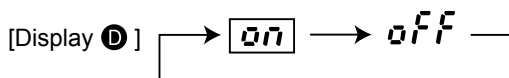

(5) While pressing the **MODE** button, press the **ON/OFF** button for 2 seconds to return to normal mode.

* If you press the **ON/OFF** button before the **MODE** button, the settings you have made will be cancelled.

■ Day of the week and time setting

- The day of the week and time can be set and changed.

[The time can be set in 1-minute increments.]

Notes

- This setting is not possible if the clock function is disabled by the function setting.
- The day of the week and time are not displayed if the clock function is disabled by function selection.
- This setting is not possible if the simple timer or auto off timer has been selected.

Setting the Day of the Week and Time

■ Display example

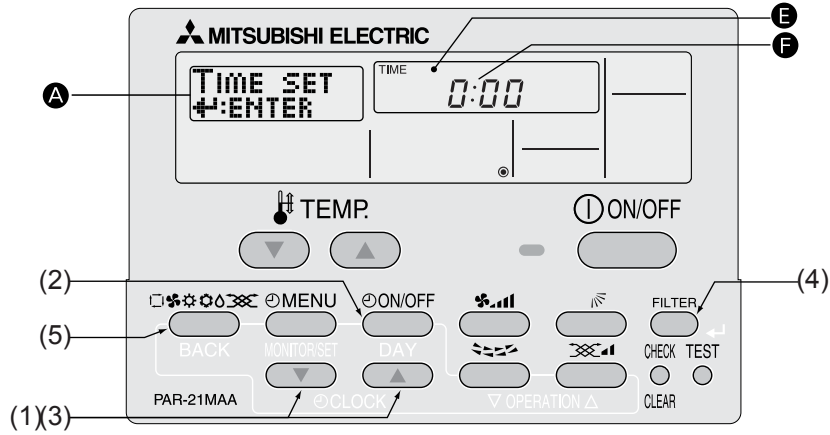

(1) Press the [CLOCK] buttons (and) to display **TIME SET** :ENTER on the screen (at **A**).

(2) Press the button until the desired day of the week appears.

[Display **B**] Sun Mon Tue Wed Thu Fri Sat

(3) Press the [CLOCK] buttons (and) to set the desired time.

Press the [CLOCK] buttons (and) longer will switch the time in 10-minute and 1-hour increments.

[Display **C**] One-minute Ten-minute One hour

(4) Press the () button to confirm the time

Note

The time you have set can be cancelled by pressing the (BACK) button without confirming it

(5) Press the (BACK) button to return to the normal screen and complete the day of the week/time setting.

* The day of the week and time you have set are displayed on the normal screen.

① Weekly Timer

- The weekly timer allows you to set up to 8 operations per day of the week.
 - For each operation, you can set the ON (start) or OFF (stop) timer and temperature. The start timer, stop timer and temperature can also be set individually.
 - The air conditioner is operated at the times you have set and according to the settings you have made.
- The time for the weekly timer can be set in 1-minute increments.
 - * If "OFF" is selected to disable the clock function, the weekly timer cannot be used to make day of the week/time settings. To use the weekly timer to set the day of the week and time, the clock function must be set to "ON" (default). (Refer to 4.3.2)

Note

With the weekly timer, it is not possible to designate an operation mode.
The air conditioner will be operated in the currently selected operation mode. (Cool, Dry, Heat or Auto)

How to set the Weekly Timer

■ Display example (for *no1*)

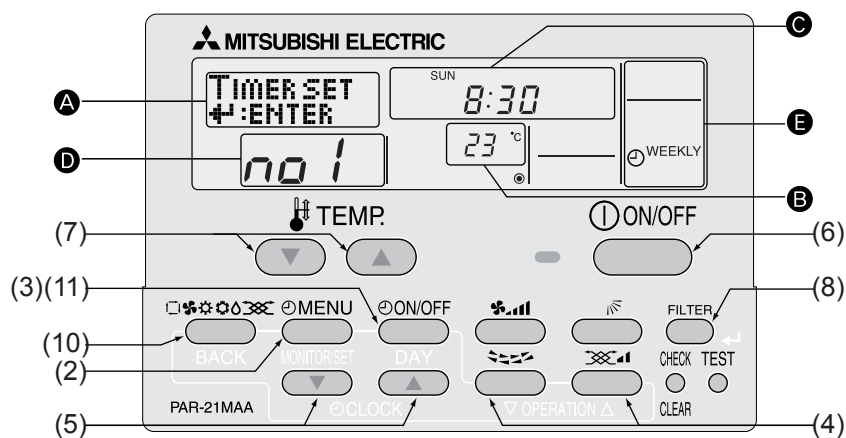

- (1) Make sure that "WEEKLY" is displayed on the screen (at **E**).
- (2) Press the **MENU** button to select **TIME SET** / **ENTER** on the screen (at **A**).



- (3) Press the **ON/OFF** button until the desired day of the week appears.

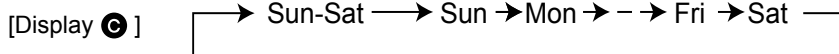

- (4) Press the **OPERATION** and **DAY** buttons to set the desired operation No. (Up to 8 patterns can be set.)

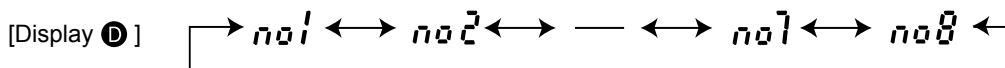

* A cell from the following setup matrix is selected according to the settings you have made in steps (2) and (3).

Set up Matrix

| Op No. | Sunday | Monday | ... | Saturday |
|--------|---------------------------|------------------|------------------|------------------|
| no1 | • 8:30 • ON • 23 °C | | | |
| no2 | • 10:00 • OFF | • 10:00 • OFF | • 10:00 • OFF | • 10:00 • OFF |
| ... | | | | |
| no8 | | | | |

- Setting contents -
Starts the air conditioner at 8:30 with the temperature set to 23 °C.

- Setting contents -
Stops the air conditioner at 10:00.

Note

If "Sun – Sat" is set in step (3), the same pattern can be set for each day of the week.
The same pattern is set in the shaded areas in the above setup matrix.
(Example: Selecting "Sun – Sat" and setting operation No. "no2")

(5) Press the [CLOCK] buttons (∇) and (Δ) to set the desired time. (0:00 to 23:59)

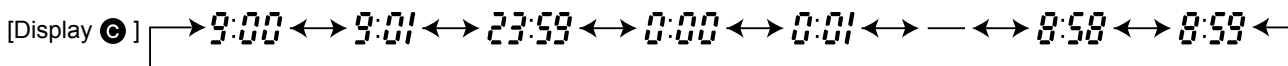

(6) Press the (ON/OFF) button to select whether to start or stop the air conditioner at the time you have set in step (5).

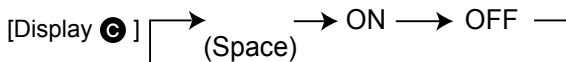

(7) Press the [TEMP] buttons (∇) and (Δ) to set the desired room temperature. (12 °C to 30 °C)

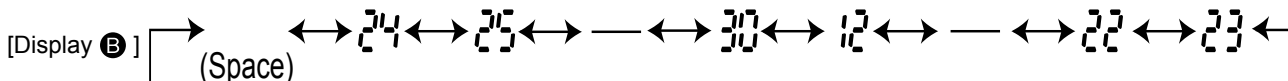

Temperature setting range : The temperature can be set within a range of 12 °C to 30 °C. However, the setting range varies with the type of the air conditioner. (Refer to 4-2-3.)

(8) After completing the settings in steps (4) to (7), press the (FILTER) (\leftarrow) button to confirm them.

To cancel the settings you have made, press the (CHECK) (CLEAR) button once.

* The time setting will change to "- :- -", and the ON/OFF and temperature settings will all disappear.

(To clear all the weekly timer settings you have made, hold down the (CHECK) (CLEAR) button for 2 seconds or more until the settings blink. All of the settings will be cleared.)

Note

The settings you have made can be cancelled by pressing the (MODE) (BACK) button before pressing (FILTER) (\leftarrow) button.

When 2 or more different operations for the same time are set, only the operation with the large operation No. will be effective.

(9) Repeat steps (3) to (8) to set the contents in the setup matrix.

(10) Press the (MODE) (BACK) button to return to the normal screen and complete weekly timer setting.

(11) If you press the (ON/OFF) button, the weekly timer will start and " WEEKLY " will disappear from the screen.

Make sure that " WEEKLY " disappears.

How to Review the Weekly Timer Settings

(1) Make sure that "WEEKLY" is displayed on the screen (at **E**).

(2) Press the (MENU) button to display ^{TIMER} MONITOR on the screen (at **A**).

(3) Press the (ON/OFF) button to select the day of the week you want to check.

(4) Press the (Left Arrow) and (Right Arrow) buttons to switch the settings from one to another, one at a time.

* The settings are displayed in order of time setting.

(5) To close the ^{TIMER} MONITOR and return to the normal screen, press the (MODE) button.

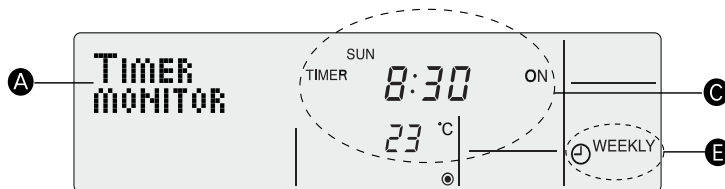

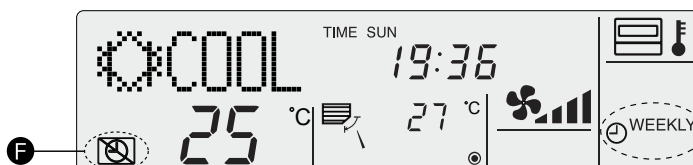

To Turn Off the Weekly Timer

(1) Press the (ON/OFF) button to display " WEEKLY " on the screen (at **F**).



To Turn On the Weekly Timer

(1) Press the  button so that  disappears from the screen (at **F**).

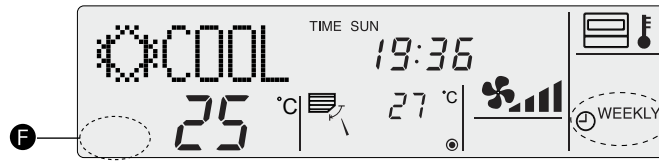

● Weekly timer setting procedure



To facilitate weekly timer setting, it is recommended to input the set up table below with the settings (day of the week, time, operation (on/off)) that you are going to make.

Weekly timer setup table (up to 8 patterns can be set for each day of the week, 56 patterns in total for a week).



| Operation No. | | Sunday | Monday | Tuesday | Wednesday | Thursday | Friday | Saturday |
|---------------|------|----------------|--------|---------|-----------|----------|--------|----------|
| 1 | no 1 | Time setting | | | | | | |
| | | On/off setting | | | | | | |
| | | Temperature | | | | | | |
| 2 | no 2 | Time setting | | | | | | |
| | | On/off setting | | | | | | |
| | | Temperature | | | | | | |
| 3 | no 3 | Time setting | | | | | | |
| | | On/off setting | | | | | | |
| | | Temperature | | | | | | |
| 4 | no 4 | Time setting | | | | | | |
| | | On/off setting | | | | | | |
| | | Temperature | | | | | | |
| 5 | no 5 | Time setting | | | | | | |
| | | On/off setting | | | | | | |
| | | Temperature | | | | | | |
| 6 | no 6 | Time setting | | | | | | |
| | | On/off setting | | | | | | |
| | | Temperature | | | | | | |
| 7 | no 7 | Time setting | | | | | | |
| | | On/off setting | | | | | | |
| | | Temperature | | | | | | |
| 8 | no 8 | Time setting | | | | | | |
| | | On/off setting | | | | | | |
| | | Temperature | | | | | | |

Operation No. : Use the  and  buttons to select the desired operation No.

Day of the week : Use the  button to select the desired day. ("Sun to Sat", "Sun", "Mon", "Tue", "Wed", "Thu", "Fri" or "Sat" can be selected.)

Time : Use the [CLOCK] buttons ( and ) to set the desired time. (The time can be set from 0:00 to 23:59 in 1-minute increments.)

Operation (ON/OFF) : Use the  button to select the desired operation (ON, OFF, _(space)).

Temperature : Press the [TEMP] buttons ( and ) to set the desired temperature.

② Auto Off Timer

- The auto off timer begins counting down when the air conditioner starts, and shuts off the air conditioner when the set time passed.
- The time on the auto off timer can be set in a range of 30 minutes to 4 hours, in 30-minute increments.

* By default, the weekly timer is selected as the remote controller's timer function.

To use the auto off timer, switch the timer function to the auto off timer using the remote controller's function selection.

Note 1 : If the auto off timer is selected, it is not possible to use the weekly and simple timers.

Note 2 : Timer operation is not possible when:

A timer is operating, an error has occurred, the air conditioner is operating, the remote controller is diagnosing a problem, function selection is in progress, timer setting is in progress, or the system is centrally controlled.
(ON/OFF operation is prohibited under the above conditions.)

Selecting the Auto Off Timer

■ Display example

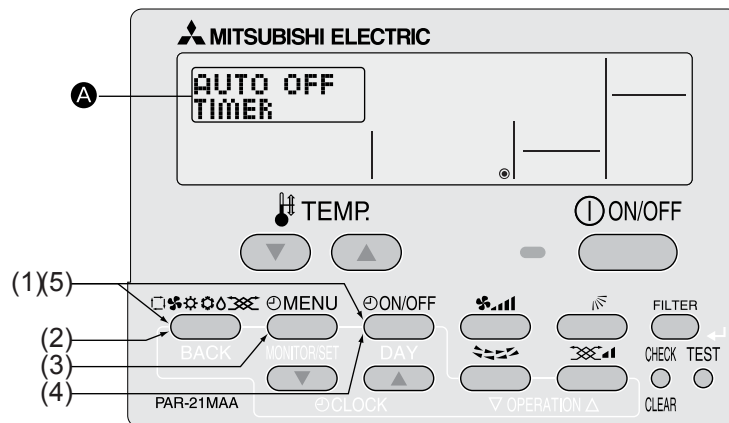

Steps (1) to (5) are necessary when switching the timer function from simple timer, weekly timer and no timer.

(1) While pressing the **MODE** button, press the **ON/OFF** button for 2 seconds to activate the remote controller's function selection mode.

(2) Press the **MODE** button until **MODE SELECTION** appears on the screen (at **A**).



(3) Press the **MENU** button so that "Timer" appears on the screen (at **A**).

(4) Press the **ON/OFF** button until **AUTO OFF TIMER** appears on the screen (at **A**).



(5) While pressing the **MODE** button, press the **ON/OFF** button for 2 seconds to return to normal mode.

* If you press the **ON/OFF** button before the **MODE** button, the settings you have made will be cancelled.

How to Set the Auto Off Timer

■ Display example

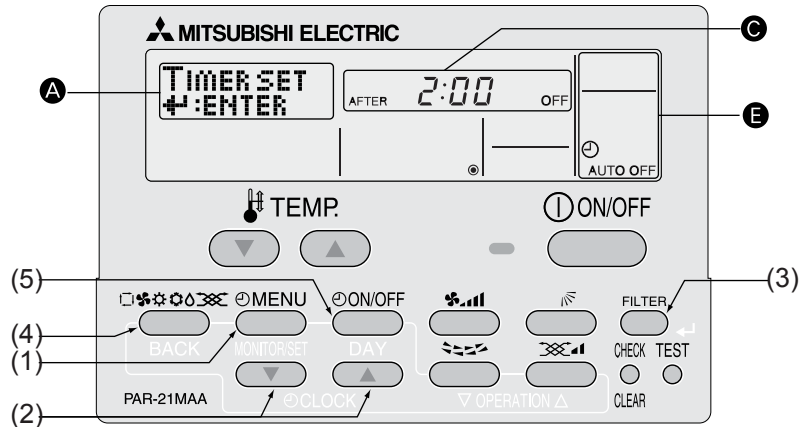

- (1) Press the **[MENU]** button for 3 seconds so that **TIMER SET** **↵:ENTER** appears on the screen (at **A**).

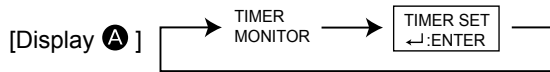

- (2) Press the **[CLOCK]** buttons (**▽** and **△**) to set the desired time.
(The time can be set up to 4 hours in 30-minute increments.)

[Display **C**] **0:30** ↔ **1:00** ↔ — ↔ **3:30** ↔ **4:00**

- (3) Press the **[FILTER]** (**←**) button to confirm the setting
(4) Press the **[MODE]** button to complete the setting procedure.

[Set display example]

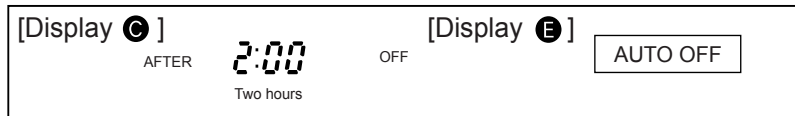

Checking the Current Auto Off Timer Setting

- (1) Make sure that **AUTO OFF** is displayed on the screen (at **E**).
(2) Press the **[MENU]** button for 3 seconds to display **TIMER MONITOR** on the screen (at **A**).
• The time you have set is displayed.
(3) To close the **TIMER MONITOR** and return to the normal screen, press the **[MODE]** button.

■ Display example

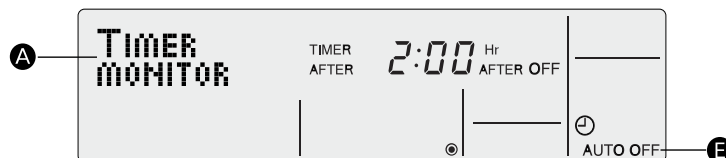

To Turn Off the Auto Timer...

(1) Press the  ON/OFF button for 3 seconds so that the timer execution time disappears from the screen (at **C**).



- If the air conditioner is operated with the auto off timer turned OFF,  will appear on the screen (at **F**).

* The auto off timer will be effective the next time that the air conditioner is operated.

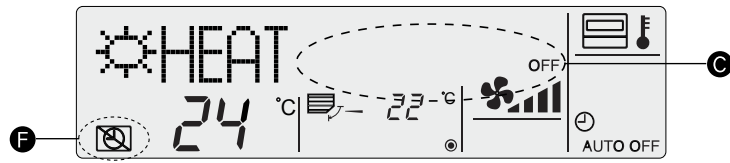
■ Display example (auto off timer is off)



To Turn On the Auto Off Timer...

(1) Press the  ON/OFF button for 3 seconds while the timer is OFF, so that  disappears from the screen (at **F**) and the timer execution time appears on the screen (at **C**).

* The timer execution time that was set previously will be displayed.

■ Display example (auto off timer is on)

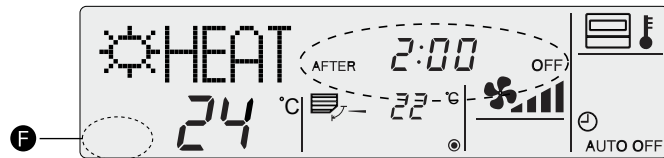

③ Simple Timer

- You can set the simple timer in any of 3 ways.
 - Start time only : The air conditioner starts when the set time has passed.
 - Stop time only : The air conditioner stops when the set time has passed.
 - Start & Stop times : The air conditioner starts and stops at the respective passed times.
- The simple timer (Start and stop) can be set only once within a 72-hour period.
The time setting is made in hour increments.

Note 1: Timer operation is not possible when:

A timer is operating, an error has occurred, the air conditioner is operating, the remote controller is diagnosing a problem, function selection is in progress, timer setting is in progress, or the system is centrally controlled.
(ON/OFF operation is prohibited under the above conditions.)

- If the simple timer is not currently selected, select it and make the necessary changes to the current settings as explained below.

Switching to the simple timer

■ Display example

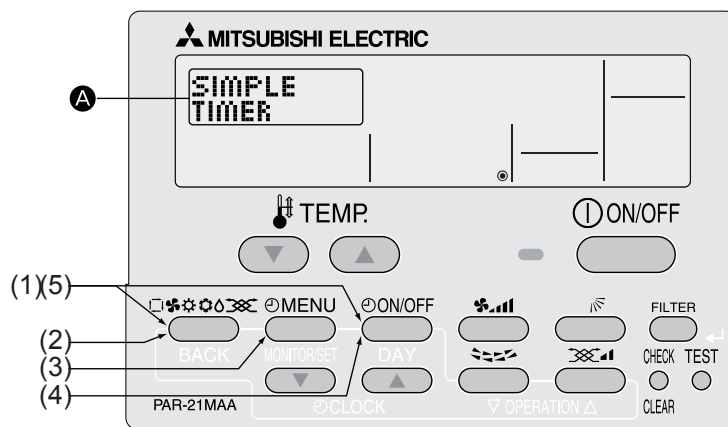

Steps (1) to (5) are necessary when switching the timer function from auto off timer, weekly timer and no timer.

(1) While pressing the **MODE** button, press the **ON/OFF** button for 2 seconds to activate the remote controller's function selection mode.

(2) Press the **MODE** button until **MODE SELECTION** appears on the screen (at **A**).



(3) Press the **MENU** button so that "TIMER" appears on the screen (at **A**).

(4) Press the **ON/OFF** button until "SIMPLE TIMER" appears on the screen (at **A**).

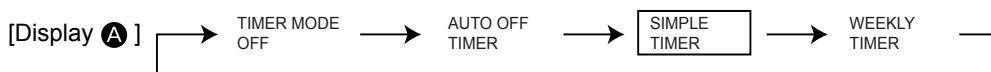

(5) While pressing the **MODE** button, press the **ON/OFF** button for 2 seconds to return to normal mode.

* If you press the **ON/OFF** button before the **MODE** button, the settings you have made will be cancelled.

How to Set the Simple Timer

■ Display example

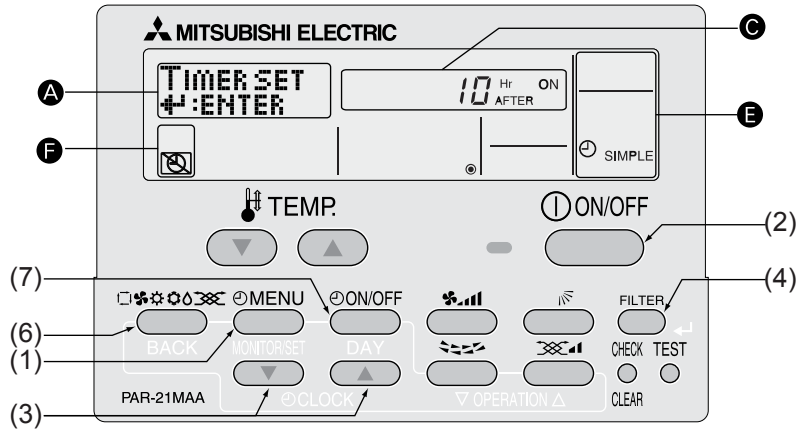

Make sure that “SIMPLE TIMER” is displayed on the screen (at **E**).

(1) Press the **[MENU]** button to select **TIME SET** **↵:ENTER** on the screen (at **A**).



(2) Press the **[ON/OFF]** button to select “Start time only” or “Stop time only”.

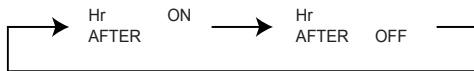

- Start time only (Displays the time at which the air conditioner starts) : “Hr AFTER ON”
- Stop time only (Displays the time at which the air conditioner stops) : “Hr AFTER OFF”

(3) Press the **[CLOCK]** buttons (**▽** and **△**) to set the desired time. (The time can be set up to 72 hours in 1-hour increments.)

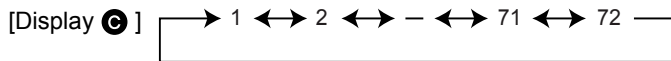

* To cancel the time you have set, press the **[CHECK]** (CLEAR) button.

(4) Press the **[FILTER]** (**↵**) button to confirm the setting

*1. When using only the start timer or stop timer, make sure that “–” is displayed for the timer you are not going to use.

*2. To cancel the time you have set, press the **[CHECK]** (CLEAR) button to display “–”, and then press the **[FILTER]** (**↵**) button to confirm it.

(5) When using both the start and stop timers, carry out steps (2) to (4) to set both the start and stop times.

* It is not possible to set the same time for both the start and stop times.

(6) Press the **[MODE]** button to complete the setting procedure.

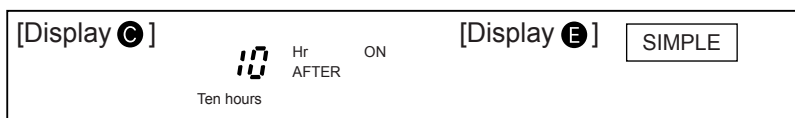

(7) Press the **[ON/OFF]** button. The simple timer will start to operate and the timer execution time you have set will be displayed.

If both start and stop timers are set, whichever time will come first will be displayed

Review the Current Simple Timer Settings

- (1) Be sure that the "SIMPLE" indicator is visible on the screen (at **E**).
- (2) Press the **MENU** button, so that the **TIMER MONITOR** appears on the screen (at **A**).
 - The time you have set to start or stop the timer appears on the screen (at **C**).
- (3) Press the **MODE** button to close the **TIMER MONITOR** display and return to the standard control screen.

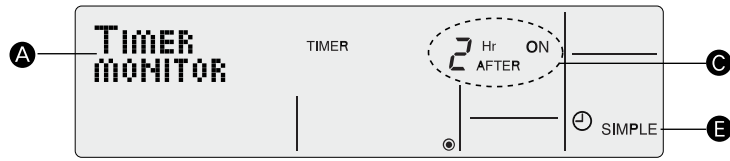

To Turn Off the Simple Timer...

- (1) Press the **ON/OFF** button so that the timer setting no longer appears on the screen (at **C**).

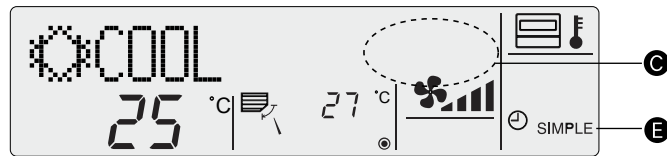

Examples

- 1 Start timer operation : Operation starts after 2 hours.
- 2 Stop timer operation : Operation stops after 10 hours.
- 3 Timer cancelled : Timer setting no longer appears

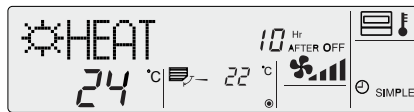
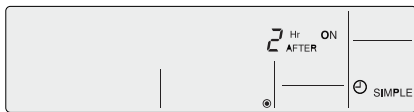

- 4 When both the start and stop timers are set

Example 1 : To activate the on timer first

Time set for the on timer: ON after 3 hours
Time set for the off timer: OFF after 7 hours

Once 7 hours have elapsed, the air conditioner will remain stopped until an operation is performed.

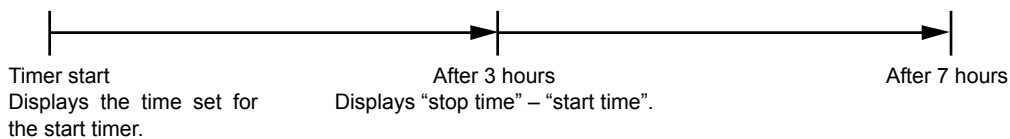
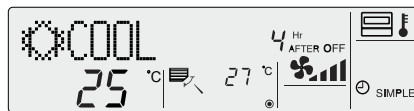
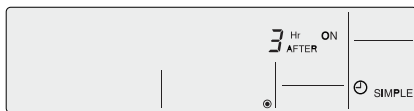

Example 2 : To activate the off timer first

Time set for the off timer: OFF after 2 hours
Time set for the on timer: ON after 5 hours

Once 5 hours have elapsed, the air conditioner will continue operating until an operation is performed.

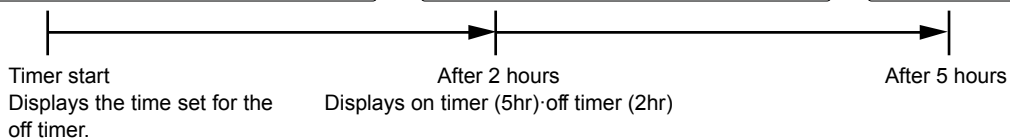
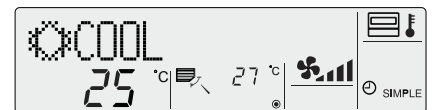
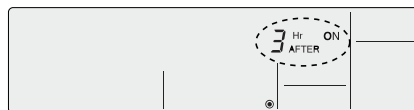
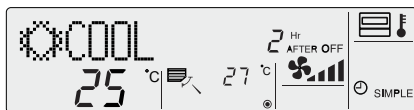

④ Timer Mode Off

Timer mode cannot be used.

■ Display example

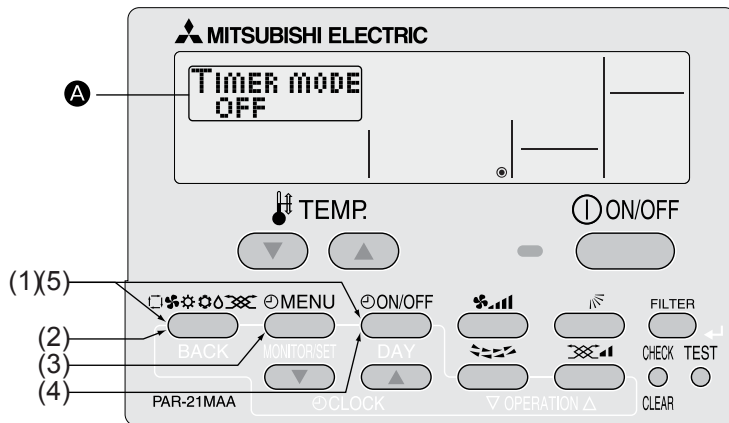

How to set the Timer mode Off

(1) While pressing the **MODE** button, press the **ON/OFF** button for 2 seconds to activate the remote controller's function selection mode.

(2) Press the **MODE** button until **A** appears on the screen (at **A**).



(3) Press the **MENU** button so that "TIMER" appears on the screen (at **A**).

(4) Press the **ON/OFF** button until "TIMER MODE OFF" appears on the screen (at **A**).

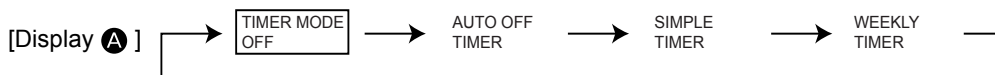

(5) While pressing the **MODE** button, press the **ON/OFF** button for 2 seconds to return to normal mode.

* If you press the **ON/OFF** button before the **MODE** button, the settings you have made will be cancelled.

4.3.3 Contact Number Setting for Error Situation

The following settings can be made.

- ① CALL • OFF (default) : The preset contact number is not displayed even when an error occurs.
- ② CALL • ***** : The preset contact number is displayed when an error occurs. (The contact number can consist of up to 12 digits.)
- CALL • – : The contact number is not set in default setting. It is displayed.

Setting the Contact Numbers

■ Display example

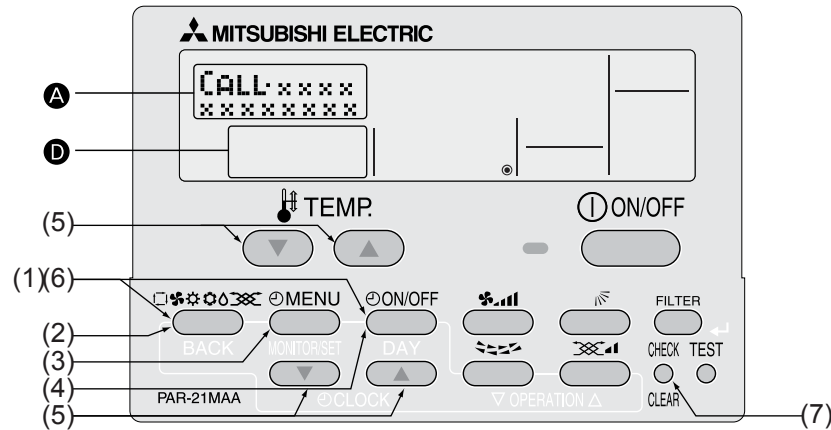

(1) While pressing the **MODE** button, press the **ON/OFF** button for 2 seconds to activate the remote controller's function selection mode.

(2) Press the **MODE** button until appears on the screen (at **A**).



(3) Press the **MENU** button until "CALL" appears on the screen (at **A**).

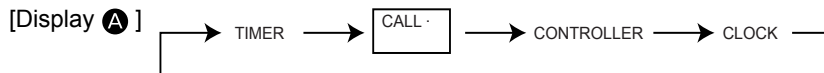

(4) Press the **ON/OFF** button to select whether or not to show the contact number.

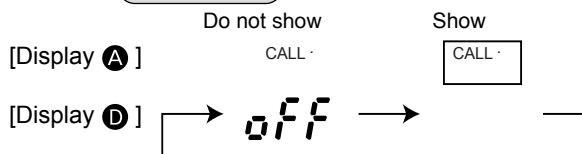

(5) Press the **CLOCK** buttons (**▽** and **△**) to set the desired contact number, one digit at a time. To move the input digit position left or right, press the **TEMP** buttons (**▽** and **△**).

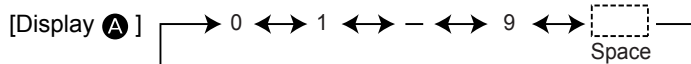

The contact number can contain up to 12 digits.

[When entering "012"]

[Display **A**] CALL • 012_

"0" → Press the **CLOCK** button (**△**) once.

Each time a value is entered, press the **TEMP** button (**△**) to move the cursor to the next digit to the right.

"1" → Press the **CLOCK** button (**△**) twice.

"2" → Press the **CLOCK** button (**△**) 3 times.

(6) While pressing the **MODE** button, press the **ON/OFF** button for 2 seconds to return to normal mode.

* If you press the **ON/OFF** button before the **MODE** button, the settings you have made will be cancelled.

(7) If you press the **CHECK** (CLEAR) button, the contact number will be displayed for 5 seconds.

- Once the contact number has been set, the error code and contact number will be displayed alternately when an error occurs.

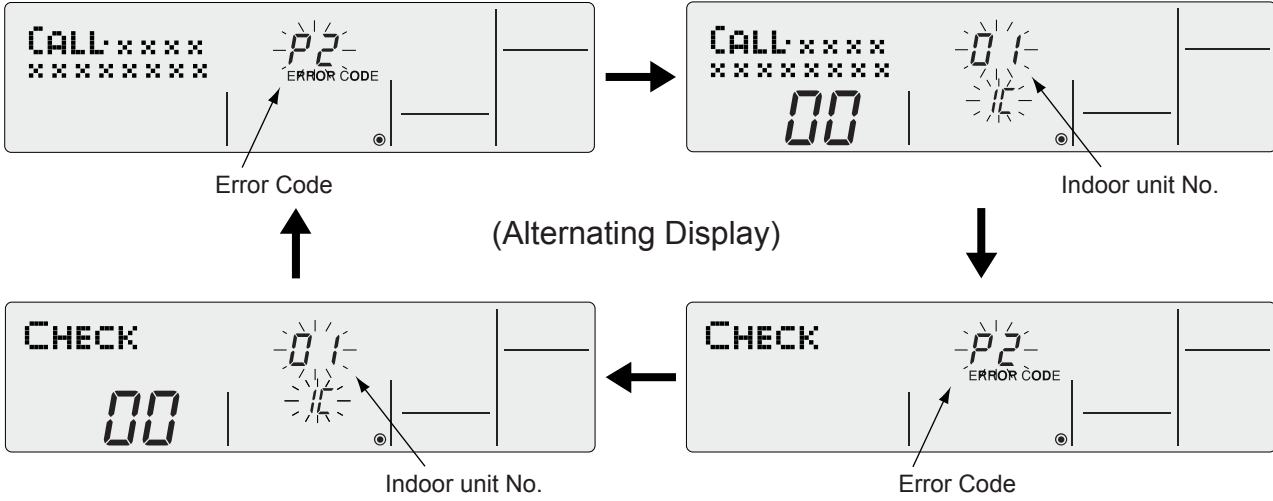

4.4 Display Change Setting

4.4.1 Temperature Display °C/°F Setting

The following settings can be made.

- ① °C(default) : Temperatures are displayed in Celsius.
- ② °F : Temperatures are displayed in Fahrenheit.
(Degrees F = 1.8 × degrees C + 32)

Switching the Temperature Display Unit between °F and °C

■ Display example

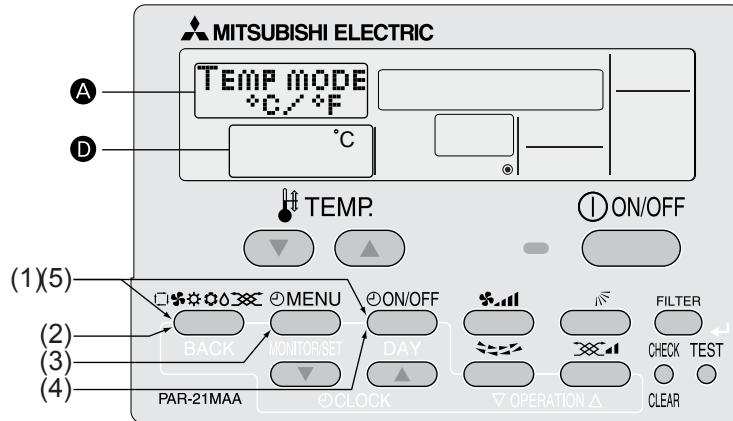

(1) While pressing the **MODE** button, press the **ON/OFF** button for 2 seconds to activate the remote controller's function selection mode.

(2) Press the **MODE** button until **DISP MODE SETTING** appears on the screen (at **A**).

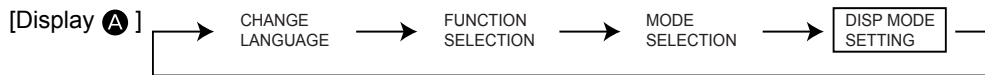

(3) Press the **MENU** button to select "TEMP MODE °C/°F" on the screen (at **A**).

(4) Press the **ON/OFF** button to select "°C" or "°F" on the screen (at **D**).

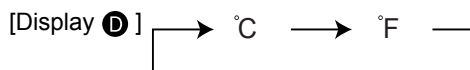

(5) While pressing the **MODE** button, press the **ON/OFF** button for 2 seconds to return to normal mode.

* If you press the **ON/OFF** button before the **MODE** button, the settings you have made will be cancelled.

■ Temperature display example when "°C" is selected

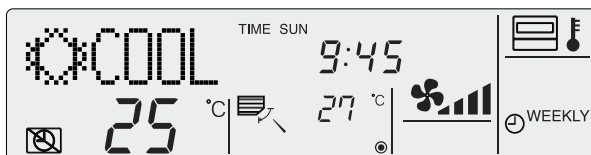

■ Temperature display example when "°F" is selected

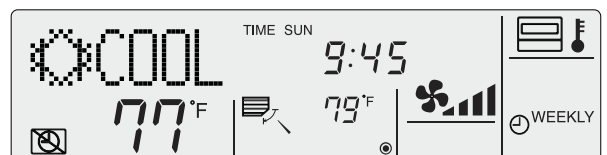

4.4.2 Room Temperature Display Setting

The following settings can be made.

- ① ON (default) : The room temperature is displayed.
- ② OFF : The room temperature is not displayed.

Setting the Room Temperature

■ Display example

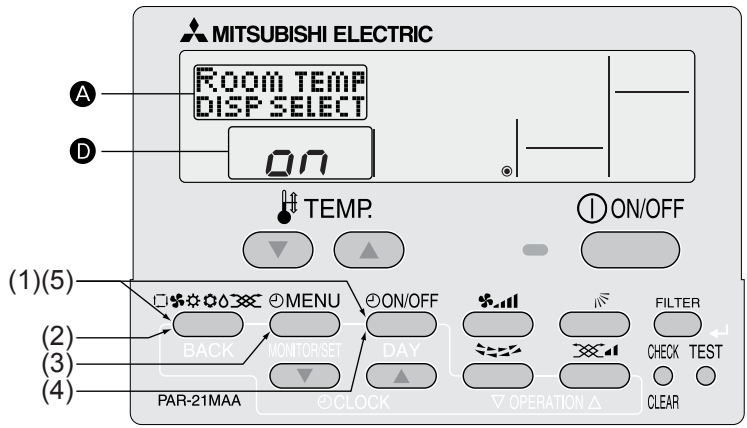

(1) While pressing the **MODE** button, press the **ON/OFF** button for 2 seconds to activate the remote controller's function selection mode.

(2) Press the **MODE** button until **DISP MODE SETTING** appears on the screen (at **A**).



(3) Press the **MENU** button so that "ROOM TEMP DISP SELECT" appears on the screen (at **A**).

(4) Press the **ON/OFF** button to select "on" or "off" on the screen (at **D**).

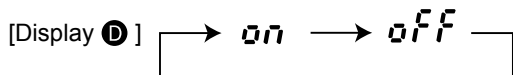

(5) While pressing the **MODE** button, press the **ON/OFF** button for 2 seconds to return to normal mode.

* If you press the **ON/OFF** button before the **MODE** button, the settings you have made will be cancelled.

■ Room temperature display example when "ON" is selected

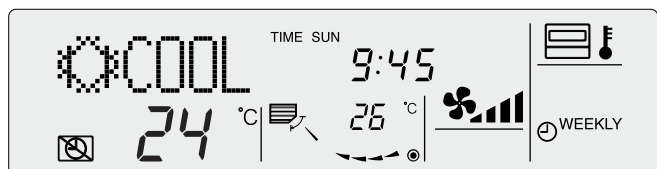

■ Room temperature display example when "OFF" is selected

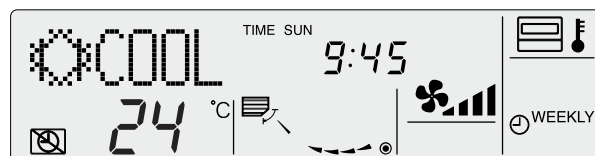

4.4.3 Automatic Cooling/Heating Display Setting

- This section explains how to set whether to display “COOL”/ “HEAT” in auto mode. It will not be displayed if auto mode is set to OFF.
- ① ON (default) : One of “Automatic cooling” and “Automatic heating” is displayed under the automatic mode is displayed.
- ② OFF : Only “Automatic” is displayed under the automatic mode.

Selecting Whether to Display “COOL”/“HEAT” in Auto Mode

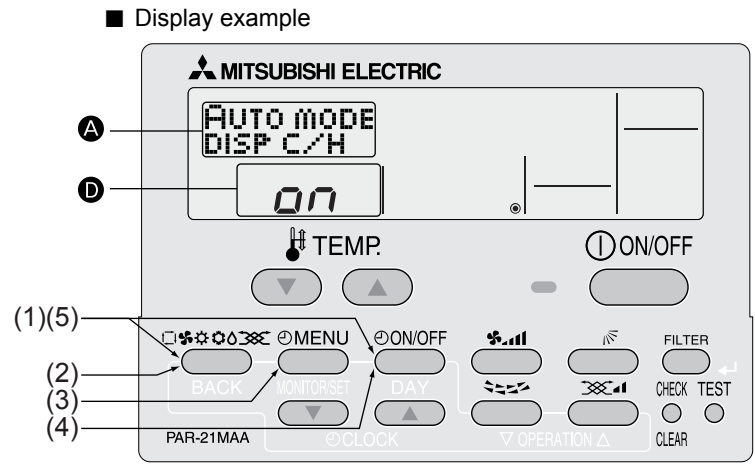

(1) While pressing the **MODE** button, press the **ON/OFF** button for 2 seconds to activate the remote controller’s function selection mode.

(2) Press the **MODE** button until **DISP MODE SETTING** appears on the screen (at **A**).

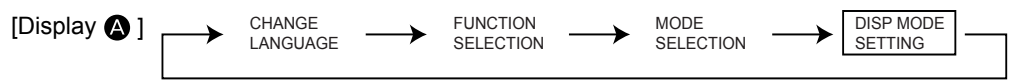

(3) Press the **MENU** button so that “AUTO MODE DISP C/H” appears on the screen (at **A**).

(4) Press the **ON/OFF** button to select “on” or “oFF” on the screen (at **D**).

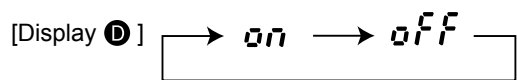

(5) While pressing the **MODE** button, press the **ON/OFF** button for 2 seconds to return to normal mode.

* If you press the **ON/OFF** button before the **MODE** button, the settings you have made will be cancelled.

■ Display example when “AUTO MODE DISP C/H” is set to “ON”

[During auto (cool) mode]



[During auto (heat) mode]

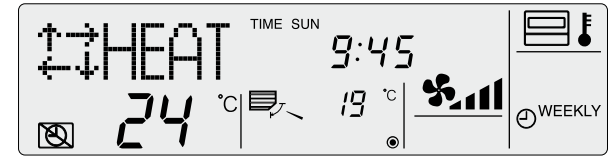

■ Display example when “AUTO MODE DISP C/H” is set to “OFF”

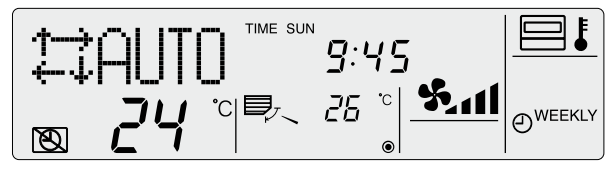

VI. Unit Function Setting by the Remote Controller (for Mr. SLIM)

Perform the following settings only to change the functions for Mr. Slim series.
(This setting is not possible with the City-Multi series.)

Each function can be set according to necessity using the remote controller. The setting of function for each unit can only be done by the remote controller. Select available function from the table. (For details regarding initial settings and operation modes of each unit, refer to the unit installation manual.)

(1) Itemised functions of the entire refrigerant system (select unit number 00)

| Function | Settings | Mode No. | Setting No. | Check | Remarks |
|------------------------------------|---|----------|-------------|-------|---------|
| Power failure automatic recovery | OFF | 1 | 1 | | |
| | ON | | 2 | | |
| Indoor temperature detecting *1 | Average data from each indoor unit | 2 | 1 | | |
| | Data from the indoor unit with remote controller | | 2 | | |
| | Data from main remote controller | | 3 | | |
| LOSSNAY connectivity | Not supported | 3 | 1 | | |
| | Supported (indoor unit does not intake outdoor air through LOSSNAY) | | 2 | | |
| | Supported (indoor unit intakes outdoor air through LOSSNAY) | | 3 | | |
| Power voltage | 240V | 4 | 1 | | |
| | 220V, 230V | | 2 | | |
| Auto operating mode *2 | Auto energy-saving operation ON | 5 | 1 | | |
| | Auto energy-saving operation OFF | | 2 | | |
| Frost prevention temperature | 2°C (Normal) | 15 | 1 | | |
| | 3°C | | 2 | | |
| Defrosting control | Standard | 17 | 1 | | |
| | For high humidity | | 2 | | |
| Refrigerant leakage setting (%) *3 | 70% (RP35, 50) / 80% (RP60-140, HRP) | 21 | 1 | | |
| | 50% (RP35, 50) / 60% (RP60-140, HRP) | | 2 | | |

*1. Can be set only when a wired remote controller is used. This function cannot be set for floor type models.

When using 2 remote controllers (two-remote controller operation), the remote controller with built-in sensor must be set as a main remote controller.

*2. Can be set only when the outdoor unit is an inverter type.

*3. Can be set only when the outdoor unit is (H)RP type.

Meaning of "Function setting"

Mode02 : indoor temperature detecting

| No. | Function | Initial setting | Diagram 1 | Diagram 2 | Diagram 3 | Diagram 4 |
|------|---|-----------------|--------------|--------------|-----------|-----------|
| No | indoor temperature(ta) | | | | | |
| No.1 | Average data of the sensor on all the indoor units | Initial setting | $ta=(A+B)/2$ | $ta=(A+B)/2$ | $ta=A$ | $ta=A$ |
| No.2 | The data of the sensor on the indoor unit that connected with remote controller | | $ta=A$ | $ta=B$ | $ta=A$ | $ta=A$ |
| No.3 | The data of the sensor on main remote controller. | | $ta=C$ | $ta=C$ | $ta=C$ | $ta=C$ |

(2) Itemised functions of the indoor unit

(select unit numbers 01 to 03 or AL [Wired remote controller] / 07 [Wireless remote controller])

| Function | Settings | Mode No. | Setting No. | Check | Remarks |
|--|---|----------|-------------|-------|----------------|
| Filter sign | 100Hr | 07 | 1 | | |
| | 2500Hr | | 2 | | |
| | "Clean the filter" indicator is not displayed | | 3 | | |
| Air flo (Fan speed) *2 | Silent Standard | 08 | 1 | | PLA-RP-AA type |
| | Standard High ceiling① | | 2 | | |
| | High ceiling High ceiling② | | 3 | | |
| No. of air outlets (not for SLZ) | 4 directions | 09 | 1 | | |
| | 3 directions | | 2 | | |
| | 2 directions | | 3 | | |
| Installed options (high performance filter) * | Not supported | 10 | 1 | | |
| | Supported | | 2 | | |
| Vane setting | No vanes (Vane No.3 setting : PLA only) | 11 | 1 | | |
| | Vane No. 1 setting | | 2 | | |
| | Vane No. 2 setting | | 3 | | |
| Swing | Not available Swing | 23 | 1 | | PLA-RP-BA type |
| | Available Wave air flo | | 2 | | |
| Set temperature in heating mode 4deg-up *1 | ON | 24 | 1 | | |
| | OFF | | 2 | | |
| Fan speed when the heat- ing thermostat is OFF *1 | Extra low | 25 | 1 | | |
| | Stop | | 2 | | |
| | Set fan speed | | 3 | | |
| Fan speed when the cool- ing thermostat is OFF | Set fan speed | 27 | 1 | | |
| | Stop | | 2 | | |
| Detection of abnormality (P8) of the pipe temperature | Detect | 28 | 1 | | |
| | Neglect | | 2 | | |

*1 SLZ/SEZ-KC/SEZ-KA type : when SW3-5 (indoor controller board) is ON, the setting of SW3 takes precedence.

| SW3 | Function setting | Dip switch | Function | Action by switch operation | |
|-----|------------------|------------|--|----------------------------|---------------|
| | | | | OFF | ON |
| | | SW3-1 | Power failure automatic recovery | OFF | ON |
| | | SW3-2 | Set temperature in heating mode (4 deg up) | Available | Not available |
| | | SW3-3 | Fan speed when the heating the thermostat is OFF | Extra low | Stop |
| | | SW3-4 | — | — | — |
| | | SW3-5* | SW3 function | Not available | Available |

- Function setting becomes effective, when the Dip switch SW3-5 is ON.
- * Switch off SW3-5 when the function setting is done by wired remote controller.
- SEZ-KD·VA(L) model is excluded.

*2 SEZ-KD · VA(L) MODE No. 08,10

| Function | Settings | Mode No. | Setting No. | Check | Remarks |
|--------------------------|------------------------------------|----------|-------------|-------|---------|
| External static pressure | 15Pa | 08 | 1 | | |
| | 35Pa | | 2 | | |
| | 50Pa | | 3 | | |
| | The same as setting of mode No. 08 | 10 | 1 | | |
| | 5Pa (set made No. 08 to 1) | | 2 | | |

Note

If a function of an indoor unit is changed by function selection after installation is complete, make sure that a "✓" mark, etc., is given in the "Check" column of Table to indicate the change

[Flow of function selection]

First, try to familiarize yourself with the flow of the function selection procedure. In this section, an example of setting the room temperature detection position is given.
For actual operations, refer to steps ① to ⑩.

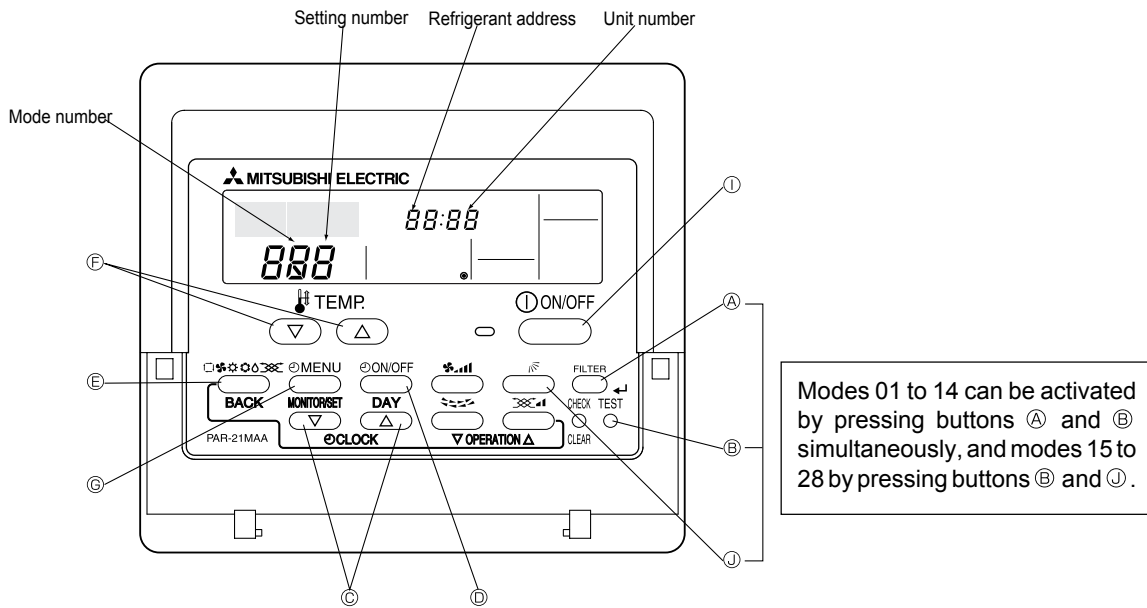

Selecting functions using the wired remote controller

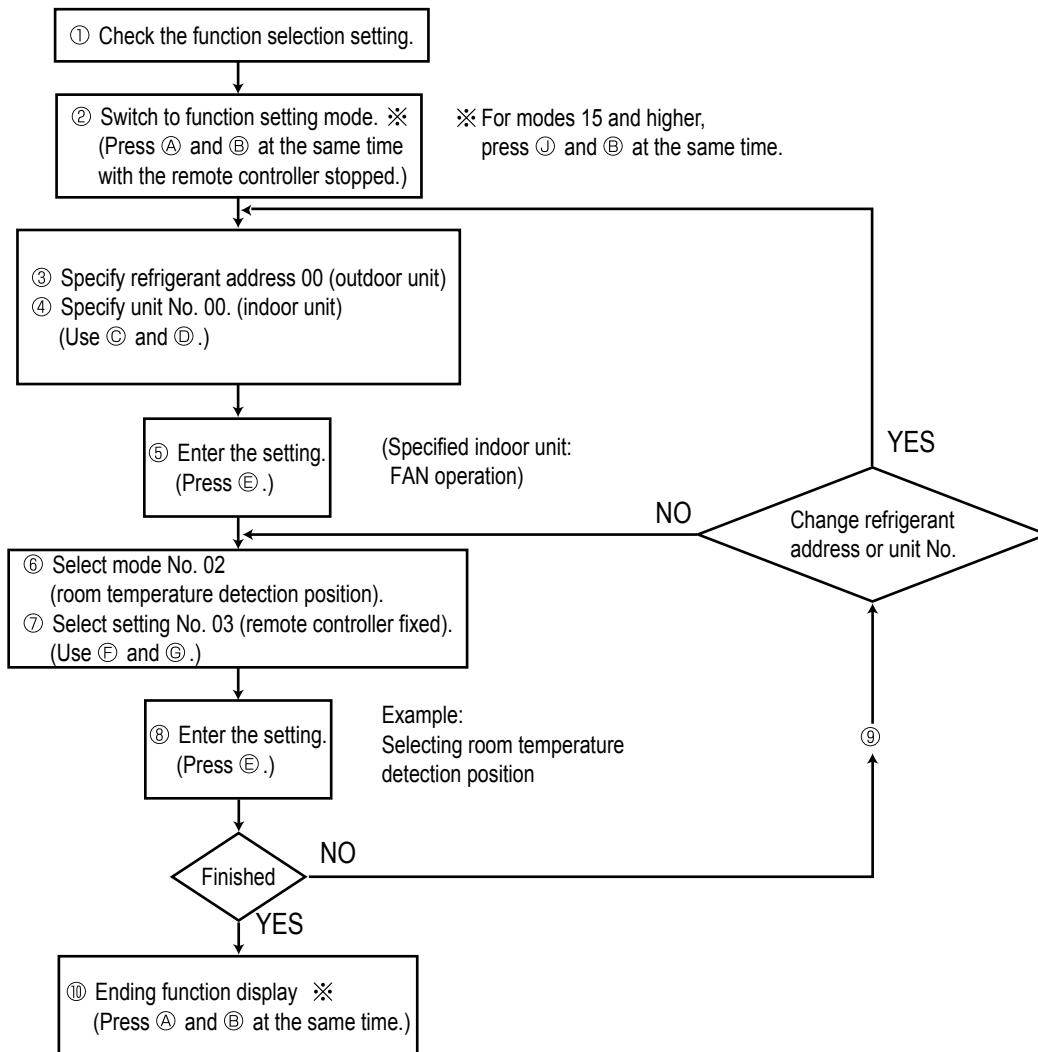

The above procedure must be carried out only if changes are necessary.

[Operating Procedure]

① Check the setting items provided by function selection.
 If settings for a mode are changed by function selection, the functions of that mode will be changed accordingly. Check all the current settings according to steps ② to ⑦, fill in the "Check" column in Table, and then change them as necessary. For initial settings, refer to the indoor unit's installation manual.

② Switch off the remote controller.

Ⓐ Hold down the **[FILTER]** (mode is 15 to 28) and **[TEST]** buttons simultaneously for at least 2 seconds. **FUNCTION SELECTION** will start to blink, and then the remote controller's display content will change as shown below.

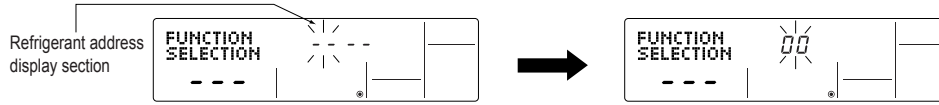

③ Set the outdoor unit's refrigerant address.

Ⓒ Press the **[CLOCK]** buttons (**[DOWN]** and **[UP]**) to select the desired refrigerant address. The refrigerant address changes from "00" to "15". (This operation is not possible for single refrigerant systems.)

* If the unit stops after **FUNCTION SELECTION** blinked for 2 seconds or "88" blinks in the room temperature display area for 2 seconds, a transmission error may have occurred. Check to see if there are any sources of noise or interference near the transmission path.

Note
 If you have made operational mistakes during this procedure, exit function selection (see step ⑩), and then restart from step ②.

④ Set the indoor unit number.

Ⓓ Press the **[ON/OFF]** button so that "-" blinks in the unit number display area.

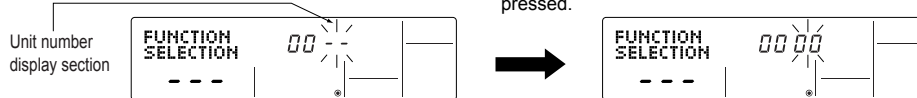

Ⓒ Press the **[CLOCK]** buttons (**[DOWN]** and **[UP]**) to select the unit number of the indoor unit for which you want to perform function selection. The unit number changes to "00", "01", "02", "03", "04" and "AL" each time a button is pressed.

* To set modes 01 to 06 or 15 to 22 select unit number "00".
 * To set modes 07 to 14 or 23 to 28 carry out as follows:
 To set each indoor unit individually, select "01" to "04".
 To set all the indoor units collectively, select "AL".

⑤ Confirm the refrigerant address and unit number.

Ⓔ Press the **[MODE]** button to confirm the refrigerant address and unit number. After a while, "-" will start to blink in the mode number display area.

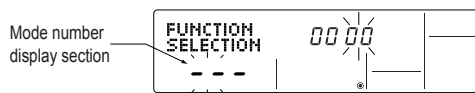

Ⓒ When the refrigerant address and unit number are confirmed by pressing the **[MODE]** button, the corresponding indoor unit will start fan operation. This helps you find the location of the indoor unit for which you want to perform function selection. However, if "00" or "AL" is selected as the unit number, all the indoor units corresponding to the specified refrigerant address will start fan operation.

Example) When the refrigerant address is set to 00 and the unit number is 02.

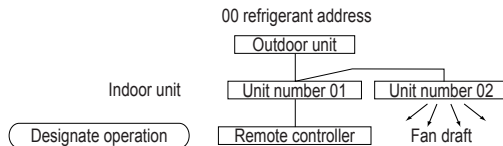

* "88" will blink in the room temperature display area if the selected refrigerant address does not exist in the system. Furthermore, if "F" appears and blinks in the unit number display area and the refrigerant address display area also blinks, there are no units that correspond to the selected unit number. In this case, the refrigerant address and unit number may be incorrect, so repeat steps ② and ③ to set the correct ones.

* When grouping different refrigerant systems, if an indoor unit other than the one to which the refrigerant address has been set performs fan operation, there may be another refrigerant address that is the same as the specified one. In this case, check the DIP switch of the outdoor unit to see whether such a refrigerant address exists.

⑥ Select the mode number.

Ⓕ Press the **[TEMP]** buttons (**[DOWN]** and **[UP]**) to set the desired mode number. (Only the selectable mode numbers can be selected.)

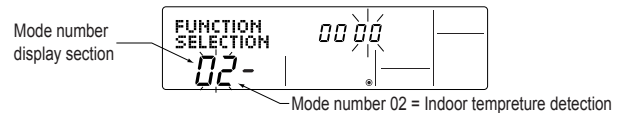

⑦ Select the setting content for the selected mode.

Ⓖ Press the **[MENU]** button. The currently selected setting number will blink, so check the currently set content.

Ⓕ Press the **[TEMP]** buttons (**[DOWN]** and **[UP]**) to select the desired setting number.

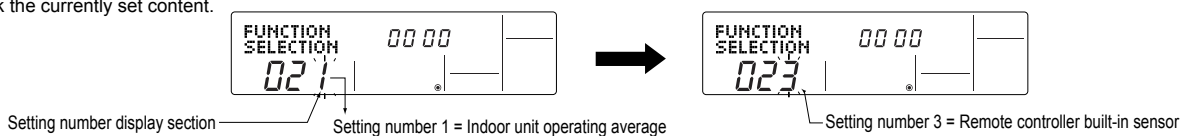

⑧ Register the settings you have made in steps ③ to ⑦.

Ⓗ Press the **[MODE]** button. The mode number and setting number will start to blink and registration starts.

The mode number and setting number will stop blinking and remain lit, indicating the end of registration.

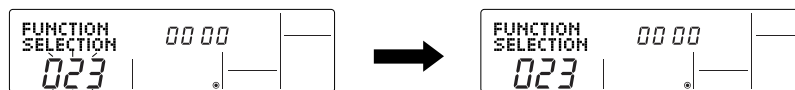

* If "-" is displayed for both the mode number and setting number and "88" blinks in the room temperature display area, a transmission error may have occurred. Check to see if there are any sources of noise or interference near the transmission path.

⑨ If you wish to continue to select other functions, repeat steps ③ to ⑧.

⑩ Complete function selection.

Ⓐ Hold down the **[FILTER]** (mode is 15 to 28) and **[TEST]** buttons simultaneously for at least 2 seconds. After a while, the function selection screen will disappear and the air conditioner OFF screen will reappear.

* Do not operate the remote controller for at least 30 seconds after completing function selection. (No operations will be accepted even if they are made.)

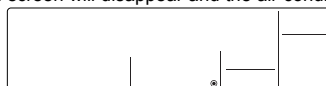

Note
 If a function of an indoor unit is changed by function selection after installation is complete, make sure that a "O" mark, etc., is given in the "Check" column of Table to indicate the change.

VII. Test Run by the Remote Controller (for Mr. SLIM)

1. Check Points Under Test Run

■ Before test run

- After installation of indoor and outdoor units, piping work and electric wiring work, re-check that there is no refrigerant leakage, loosened connections and incorrect polarity.
 - Measure impedance between the ground and the power supply terminal block(L, N) on the outdoor unit by 500V Megger and check that it is 1.0MΩ or over.
 - *Don't use 500V Megger to indoor/outdoor connecting wire terminal block(S1, S2, S3) and remote controller terminal block (1, 2). This may cause malfunction.
 - Make sure that test run switch (SW4) is set to OFF before turning on power supply.
 - Turn on power supply 12 hours before test run in order to protect compressor.
 - For specific models which requires higher ceiling settings or auto-recovery feature from power failure, make proper changes of settings referring to the description of Selection of Functions through Remote Controller.
- Make sure to read operation manual before test run. (Especially items to secure safety.)

2. Test Run using the Wired Remote Controller

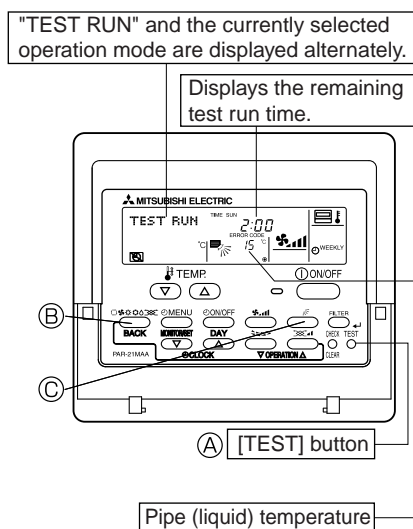

| Operating procedures | |
|---|---|
| 1. Turn on the main power supply. | While the room temperature display on the remote controller is "PLEASE WAIT", the remote controller is disabled. Wait until "PLEASE WAIT" disappears before using remote controller. "PLEASE WAIT" appears for about 2 minutes after power supply is turned on. *1 |
| 2. Press ① [TEST] button twice. | The [TEST RUN] appears on the screen. |
| 3. Press ② [OPERATION SWITCH] button. | Cooling mode: Check if cool air blows and water is drained. Heating mode: Check if warm air blows. (It takes a little while until warm air blows.) |
| 4. Press ③ [AIR DIRECTION] button. | Check for correct motion of auto-vanes. |
| 5. Check the outdoor unit's fan is rotating. | The outdoor unit features automatic capacity control to provide optimum fan speeds. Therefore, the fan keeps running at a low speed to meet the current outside air condition unless it exceeds its available maximum power. Then, in actuality, the fan may stop or run in the reverse direction depending on the outside air, but this does not mean malfunction. |
| 6. Press the ④ [ON/OFF] button to reset the test run in progress. | |
| 7. Register the contact number. (Refer to V.4.3.3.) | |

- In case of test run, the OFF timer will be activated, and the test run will automatically stop after 2 hours.
- The room temperature display section shows the pipe temperature of indoor units during the test run.
- Check that all the indoor units are running properly in case of simultaneous twin and triple operation. Malfunctions may not be displayed regardless of incorrect wiring.
- *1 After turning on the power supply, the system will go into startup mode, "PLEASE WAIT" will blink on the display section of the room temperature, and lamp(green) of the remote controller will blink.
As to INDOOR BOARD LED, LED1 will be lit up, LED2 will either be lit up in case the address is 0 or turned off in case the address is not 0. LED3 will blink.
As to OUTDOOR BOARD LED, LED1(green) and LED2(red) will lit up. (After the startup mode of the system finishes, LED2(red) will be turned off.)
In case OUTDOOR BOARD LED is digital display, [-] and [-] will be displayed alternately every second.
- If one of the above operations doesn't function correctly, the causes written below should be considered. Find causes from the symptoms.
The below symptoms are under test run mode. "start up" in the table means the display status of *1 written above.

| Symptoms in test run mode | | Cause |
|---|--|--|
| Remote Controller Display | OUTDOOR BOARD LED Display < > indicates digital display. | |
| Remote controller displays "PLEASE WAIT", and cannot be operated. | After "startup" is displayed, only green lights up. <00> | • After power is turned on, "PLEASE WAIT" is displayed for 2 minutes during system startup. (Normal) |
| After power is turned on, "PLEASE WAIT" is displayed for 3 minutes, then error code is displayed. | After "startup" is displayed, green(once) and red(once) blink alternately. <F1> | • Incorrect connection of outdoor terminal block (L1, L2, L3 and S1, S2, S3.) |
| No display appears even when remote controller operation switch is turned on. (Operation lamp does not light up.) | After "startup" is displayed, green(once) and red(twice) blink alternately. <F3, F5, F9> | • Outdoor unit's protection device connector is open. |
| | After "startup" is displayed, only green lights up. <00> | • Incorrect wiring between the indoor and outdoor unit (Polarity is wrong for S1, S2, S3.) • Remote controller transmission wire short. |
| Display appears but soon disappears even when remote controller is operated. | After "startup" is displayed, only green lights up. <00> | • There is no outdoor unit of address 0. (Address is other than 0.) • Remote controller transmission wire open. |
| | | • After canceling function selection, operation is not possible for about 30 seconds. (Normal) |

※ Press the remote controller's **CHECK** button twice to perform self-diagnosis. See the table below for the contents of LCD display. For details, please refer to " VIII.2.Error code list "

| LCD | Contents of inferior phenomena |
|------------|---|
| P1~9 | Malfunction outdoor unit |
| Fb | Malfunction indoor unit |
| U1~UP | Malfunction outdoor unit |
| F3~F9 | Malfunction outdoor unit |
| E0~E5 | Remote controller transmitting error |
| E6~EF | Indoor/outdoor unit communication error |
| ---- | No error history |
| FFFF | No applied unit |

See the table below for details of the LED display (LED 1, 2, 3) on the indoor controller board.

| | |
|-------------------------------------|---|
| LED1 (microcomputer power supply) | Lits when power is supplied. |
| LED2 (remote controller) | Lits when power is supplied for wired remote controller. The indoor unit should be connected to the outdoor unit with address "0" setting. |
| LED3 (indoor/outdoor communication) | Blink when indoor and outdoor unit are communicating. |

VIII. Self-Diagnosis by the Remote Controller (for Mr.SLIM)

1. How To Proceed "Self-Diagnosis"

1-1. When a Problem Occurs During Operation

If a problem occurs in the air conditioner, the indoor and outdoor units will stop, and the problem is shown in the remote controller display.

[CHECK] and the refrigerant address are displayed on the temperature display, and the error code and unit number are displayed alternately as shown below.

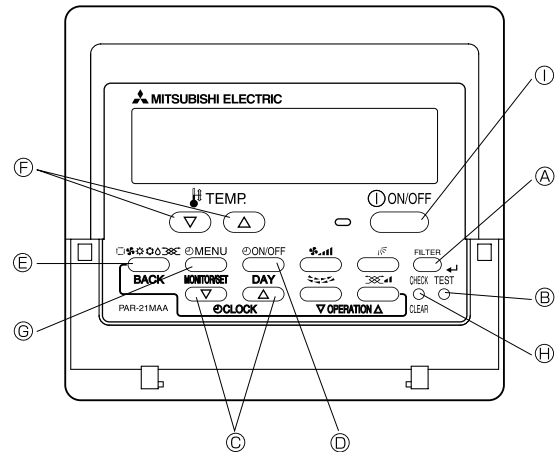

- ① (If the outdoor unit is malfunctioning, the unit number will be "00".)
- ② In the case of group control, for which one remote controller controls multiple refrigerant systems, the refrigerant address and error code of the unit that first experienced trouble (i.e., the unit that transmitted the error code) will be displayed.
- ③ To clear the error code, press the **ON/OFF** button.

(Alternating Display)

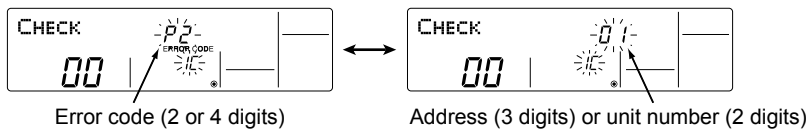

When using remote operation of remote/local combined control, clear the error code by pressing the **ON/OFF** button on remote controller after changing operation from remote to local.
 During central control by a MELANS controller, clear the error code by pressing the **ON/OFF** button on MELANS remote controller.

1-2. Self-Diagnosis During Maintenance or Service

Since each unit has a function that stores error codes, the latest check code can be recalled even if it is cancelled by the remote controller or power is shut off.

Check the error code history for each unit using the remote controller.

- ① Switch to self-diagnosis mode.
 - Ⓜ Press the **CHECK** button twice within 3 seconds. The display content will change as shown below.
- ② Set the unit number or refrigerant address you want to diagnose.
 - Ⓟ Press the [TEMP] buttons (**▽**) and (**△**) to select the desired number or address. The number (address) changes between [01] and [50] or [00] and [15].

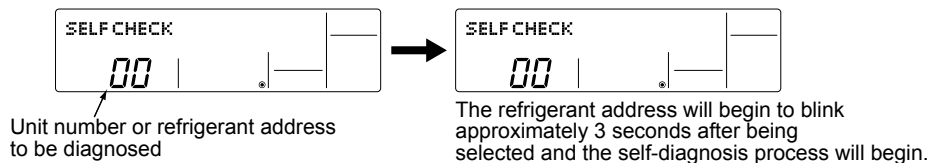

- ③ Display self-diagnosis results.
 - <When there is error code history>
 - (For the definition of each error code, refer to the indoor unit's installation manual or service handbook.)

(Alternating Display)

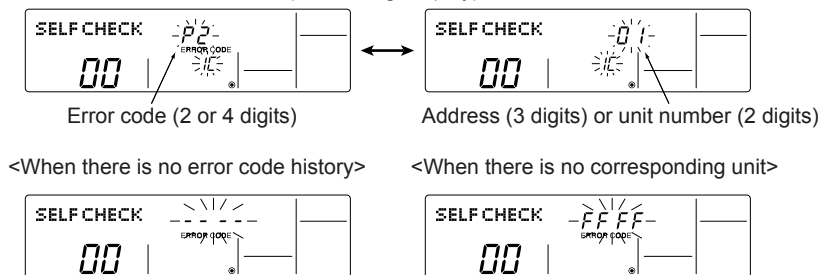

- ④ Reset the error history.
 - Display the error history in the diagnosis result display screen (see step ③).

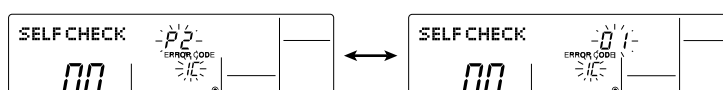

- ④ Press the **ON/OFF** button twice within 3 seconds. The self-diagnosis address or refrigerant address will blink.

When the error history is reset, the display will look like the one shown below. However, if you fail to reset the error history, the error content will be displayed again.

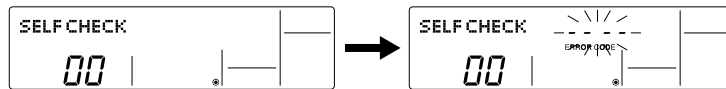

- ⑤ Cancel self-diagnosis.
Self-diagnosis can be cancelled by the following 2 methods.
- ④ Press the **CHECK** button twice within 3 seconds. → Self-diagnosis will be cancelled and the screen will return to the previous state in effect before the start of self-diagnosis.
- ⑤ Press the **ON/OFF** button. → Self-diagnosis will be cancelled and the indoor unit will stop.

1-3. Remote Controller Diagnosis

If the air conditioner cannot be operated from the remote controller, diagnose the remote controller as explained below.

- ① First, check that the power-on indicator is lit.
If the correct voltage (DC12 V) is not supplied to the remote controller, the indicator will not light.
If this occurs, check the remote controller's wiring and the indoor unit.

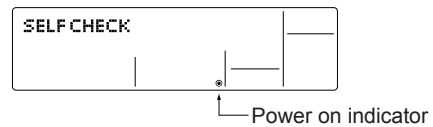

- ② Switch to the remote controller self-diagnosis mode.
- ④ Press the **CHECK** button for 5 seconds or more. The display content will change as shown below.
- ④ Press the **FILTER** button to start self-diagnosis.

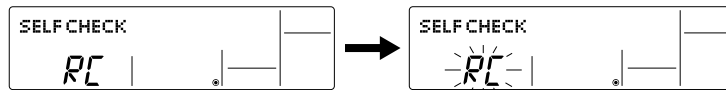

③ Remote controller self-diagnosis result

[When the remote controller is functioning correctly]

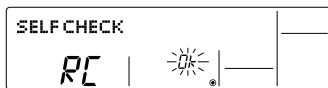

Check for other possible causes, as there is no problem with the remote controller.

[When the remote controller malfunctions]

(Error display 1) "NG" blinks. → The remote controller's transmitting-receiving circuit is defective.

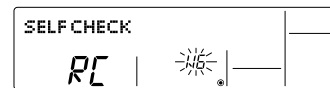

The remote controller must be replaced with a new one.

[Where the remote controller is not defective, but cannot be operated.]
(Error display 2) [E3], [6833] or [6832] blinks. → Transmission is not possible.



There might be noise or interference on the transmission path, or the indoor unit or other remote controllers are defective. Check the transmission path and other controllers.

(Error display 3) "ERC" and the number of data errors are displayed.
→ Data error has occurred.

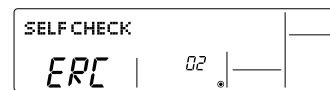

The number of data errors is the difference between the number of bits sent from the remote controller and the number actually transmitted through the transmission path. If such a problem is occurring, the transmitted data is affected by noise, etc. Check the transmission path.

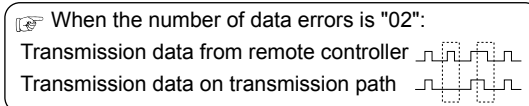

- ④ To cancel remote controller diagnosis
- ④ Press the **CHECK** button for 5 seconds or more. Remote controller diagnosis will be cancelled, "PLEASE WAIT" and operation lamp will blink. After approximately 30 seconds, the state in effect before the diagnosis will be restored.

2.Error Code List (for Mr.SLIM)

<Display function of inspection for outdoor unit>

The blinking patterns of both LED1(green) and LED2(red) indicate the types of abnormality when it occurs. Types of abnormality can be indicated in details by connecting an optional part A-Control Service Tool (PAC-SK52ST) to connector CNM on outdoor controller board.

[Display]

(1)Normal condition

| Unit condition | Outdoor controller board | | A-Control Service Tool | |
|-------------------------------|--------------------------|-------------|------------------------|------------------------------|
| | LED1 (Green) | LED2 (Red) | Error code | Indication of the display |
| When the power is turned on | Lighted | Lighted | — ↔ — | Alternately blinking display |
| When unit stops | Lighted | Not lighted | 00, etc. | Operation mode |
| When compressor is warming up | Lighted | Not lighted | 08, etc. | |
| When unit operates | Lighted | Lighted | C5, H7 etc. | |

(2)Abnormal condition

| Indication | | Error | | |
|--------------------------|------------|---|------------------|--|
| Outdoor controller board | | Contents | Error code *1 | Inspection method |
| LED1 (Green) | LED2 (Red) | | | |
| 1 blinking | 2 blinking | Connector(63L) is open. | F3 | ①Check if connector (63L or 63H) on the outdoor controller board is not disconnected. ②Check continuity of pressure switch (63L or 63H) by tester. |
| | | Connector(63H) is open. | F5 | |
| | | 2 connectors are open. | F9 | |
| 2 blinking | 1 blinking | Miswiring of indoor/outdoor unit connecting wire, excessive number of indoor units (4 units or more) | (EA) | ①Check if indoor/outdoor connecting wire is connected correctly. ②Check if 4 or more indoor units are connected to outdoor unit. ③Check if noise entered into indoor/outdoor connecting wire or power supply. ④Re-check error by turning off power, and on again. |
| | | Miswiring of indoor/outdoor unit connecting wire (converse wiring or disconnection) | (Eb) | |
| | | Startup time over | (EC) | |
| 2 blinking | | Indoor/outdoor unit communication error (signal receiving error) is detected by indoor unit. | E6 | |
| | | Indoor/outdoor unit communication error (transmitting error) is detected by indoor unit. | E7 | |
| | | Indoor/outdoor unit communication error (signal receiving error) is detected by outdoor unit. | (E8) | |
| | | Indoor/outdoor unit communication error (transmitting error) is detected by outdoor unit. | (E9) | |
| 3 blinking | | Remote controller signal receiving error is detected by remote controller. | E0 | ①Check if connecting wire of indoor unit or remote controller is connected correctly. ②Check if noise entered into transmission wire of remote controller. ③Re-check error by turning off power, and on again. |
| | | Remote controller transmitting error is detected by remote controller. | E3 | |
| | | Remote controller signal receiving error is detected by indoor unit. | E4 | |
| | | Remote controller transmitting error is detected by indoor unit. | E5 | |
| 4 blinking | | Error code is not defined. | EF | ①Check if remote controller is MA remote controller(PAR-21MAA). ②Check if noise entered into transmission wire of remote controller. ③Check if noise entered into indoor/outdoor connecting wire. ④Re-check error by turning off power, and on again. |
| 5 blinking | | Serial communication error <Communication between outdoor controller board and outdoor power board> <Communication between outdoor controller board and M-NET P.C. board> | Ed | ①Check if connector (CN4) on outdoor controller board and outdoor power board is not disconnected. ②Check if there is poor connection of connector on outdoor controller board(CNMNT and CNVMNT). ③Check M-NET communication signal. |
| | | Communication error of M-NET system | A0~A8 | |

*1.Error code displayed on remote controller.Error codes given in () are not displayed on remote controller.

| Indication | | Error | | | |
|--------------------------|------------|--|---|---|---|
| Outdoor controller board | | Contents | Error code ※1 | Inspection method | |
| LED1 (Green) | LED2 (Red) | | | | |
| 3 blinking | 1 blinking | Abnormality of shell thermistor (TH32) and discharging temperature (TH4) | U2 | ①Check if stop valves are open. ②Check if connectors (TH4, TH32, LEV-A and LEV-B) on outdoor controller board are not disconnected. ③Check if unit fills with specified amount of refrigerant ④Measure resistance values among terminals on indoor valve and outdoor linear expansion valve with a tester. | |
| | | Abnormality of superheat due to low discharge temperature | U7 | | |
| | 2 blinking | Abnormal high pressure (High pressure switch 63H worked.) | U1 | ①Check if indoor/outdoor units have a short cycle on their air ducts. ②Check if connector (63H) on outdoor controller board is not disconnected. ③Check if heat exchanger and filter is not dirt . ④Measure resistance values among terminals on linear expansion valve with a tester. | |
| | 3 blinking | Abnormality of outdoor fan motor rotational speed | U8 | ①Check the outdoor fan motor. | |
| | | Protection from overheat operation (TH3) | Ud | | |
| | 4 blinking | Compressor over current breaking (Start-up locked) | Compressor over current breaking | UF | ①Check if stop valves are open. ②Check looseness, disconnection, and converse connection of compressor wiring. ③Measure resistance values among terminals on compressor with a tester. ④Check if outdoor unit has a short cycle on its air duct. |
| | | | Abnormality of current sensor (P.B.) | UH | |
| | | | Abnormality of power module | U6 | |
| | | | | | |
| | 5 blinking | Open/short of discharge thermistor (TH4) and shell thermistor (TH32) | Open/short of outdoor thermistors (TH3, TH6, TH7 and TH8) | U3 | ①Check if connectors (TH3, TH4, TH7/6, TH32) on outdoor controller board and connector (CN3) on outdoor power board are not disconnected. ②Measure resistance value of outdoor thermistors |
| | | | | U4 | |
| | 6 blinking | Abnormality of heatsink temperature | U5 | ①Check if indoor/outdoor units have a short cycle on their air ducts. ②Measure resistance value of outdoor thermistor(TH8). | |
| | 7 blinking | Abnormality of voltage | U9 | ①Check looseness, disconnection, and converse connection of compressor wiring. ②Measure resistance value among terminals on compressor using a tester. ③Check the continuity of contactor (52C). ④Check if power supply voltage decreases. ⑤Check the wiring of CN52C. ⑥Check the wiring of CNAF. | |
| 4 blinking | 1 blinking | Abnormality of room temperature thermistor (TH1) | P1 | ①Check if connectors (CN20, CN21, CN29 and CN44) on indoor controller board are not disconnected. ②Measure resistance value of indoor thermistors. | |
| | | Abnormality of pipe temperature thermistor /Liquid (TH2) | P2 | | |
| | | Abnormality of pipe temperature thermistor/Condenser-Evaporator | P9 | | |
| | 2 blinking | Abnormality of drain sensor (DS) Float switch (FS) connector open | P4 | ①Check if connector (CN31,CN4F) on indoor controller board is not disconnected. ②Measure resistance value of indoor thermistors. ③Measure resistance value among terminals on drain-up machine using a tester. ④Check if drain-up machine works. ⑤Check drain function. | |
| | | Indoor drain overflow protectio | P5 | | |
| | 3 blinking | Freezing (cooling)/overheating (heating) protection | P6 | ①Check if indoor unit has a short cycle on its air duct. ②Check if heat exchanger and filter is not dirt . ③Measure resistance value on indoor and outdoor fan motors. ④Check if the inside of refrigerant piping is not clogged. | |
| | 4 blinking | Abnormality of pipe temperature | P8 | ①Check if indoor thermistors (TH2 and TH5) are not disconnected from holder. ②Check if stop valve is open. ③Check converse connection of extension pipe. (on plural units connection) ④Check if indoor/outdoor connecting wire is connected correctly. (on plural units connection) | |
| | 5 blinking | Abnormality of Indoor controller board | Fb | ①Replace indoor controller board. | |
| — | — | Abnormality of remote controller board | E1, E2 | ①Replace the remote controller. | |

※1. Error code displayed on remote controller. Error codes given in () are not displayed on remote controller.

IX. Monitoring the Operation Data by the Remote Controller (for Mr. SLIM PUHZ series)

1. How to "Monitor the Operation Data"

- Turn on the [Monitoring the operation data]

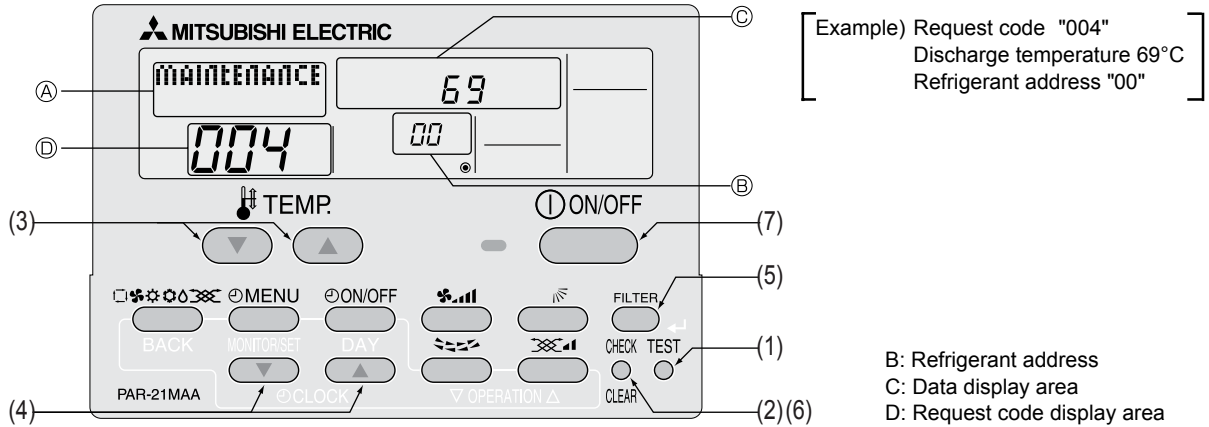

(1) Press the **TEST** button for 3 seconds so that [Maintenance mode] appears on the screen (at ①).

(2) Press the **CHECK** button for 3 seconds to switch to [Maintenance monitor].

Note) It is not possible to switch to [Maintenance monitor] during data request in maintenance mode (i.e., while "----" is blinking), since no buttons are operative.

- Operating the service inspection monitor

[- - -] appears on the screen (at ②) when [Maintenance monitor] is activated.

(The display (at ②) now allows you to set a request code No.)

(3) Press the [TEMP] buttons (**▽** and **△**) to select the desired refrigerant address.



(4) Press the [CLOCK] buttons (**▽** and **△**) to set the desired request code No.

(5) Press the **FILTER** button to perform data request.

(The requested data will be displayed at ③ in the same way as in maintenance mode.)

Data collected during operation of the remote controller will be displayed.

The collected data such as temperature data will not be updated automatically even if the data changes.

To display the updated data, carry out step (4) again.

- Canceling the Monitoring the operation data

(6) While [Maintenance monitor] is displayed, press the **CHECK** button for 3 seconds to return to maintenance mode.

(7) To return to normal mode, press the **ON/OFF** button.

2. Request Code List

* Certain indoor/outdoor combinations do not have the request code function; therefore, no request codes are displayed.

| Request code | Request content | Description (Display range) | Unit | Remarks |
|--------------|---|--|-----------|--|
| 0 | Operation state | Refer to 2-1. Detail Contents in Request Code. | – | |
| 1 | Compressor-Operating current (rms) | 0 – 50 | A | |
| 2 | Compressor-Accumulated operating time | 0 – 9999 | 10 hours | |
| 3 | Compressor-Number of operation times | 0 – 9999 | 100 times | |
| 4 | Discharge temperature (TH4) | 3 – 217 | °C | |
| 5 | Outdoor unit - Liquid pipe 1 temperature (TH3) | -40 – 90 | °C | |
| 6 | Outdoor unit - Liquid pipe 2 temperature | -40 – 90 | °C | |
| 7 | Outdoor unit-2-phase pipe temperature (TH6) | -39 – 88 | °C | |
| 8 | Outdoor unit-Suction pipe temperature (TH32) | -39 – 88 | °C | PUHZ-HRP type |
| 9 | Outdoor unit-Outside air temperature (TH7) | -39 – 88 | °C | |
| 10 | Outdoor unit-Heatsink temperature (TH8) | -40 – 200 | °C | |
| 11 | | | | |
| 12 | Discharge superheat (SHd) | 0 – 255 | °C | |
| 13 | Sub-cool (SC) | 0 – 130 | °C | |
| 14 | | | | |
| 15 | | | | |
| 16 | Compressor-Operating frequency | 0 – 255 | Hz | |
| 17 | Compressor-Target operating frequency | 0 – 255 | Hz | |
| 18 | Outdoor unit-Fan output step | 0 – 10 | Step | |
| 19 | Outdoor unit-Fan 1 speed (Only for air conditioners with DC fan motor) | 0 – 9999 | rpm | |
| 20 | Outdoor unit-Fan 2 speed (Only for air conditioners with DC fan motor) | 0 – 9999 | rpm | "0" is displayed if the air conditioner is a single-fan type. |
| 21 | | | | |
| 22 | LEV (A) opening | 0 – 500 | Pulses | |
| 23 | LEV (B) opening | 0 – 500 | Pulses | |
| 24 | LEV (C) opening | 0 – 500 | Pulses | |
| 25 | Primary current | 0 – 50 | A | |
| 26 | DC bus voltage | 180 – 370 | V | |
| 27 | | | | |
| 28 | | | | |
| 29 | Number of connected indoor units | 0 – 4 | Units | |
| 30 | Indoor unit-Setting temperature | 17 – 30 | °C | |
| 31 | Indoor unit-Intake air temperature <Measured by thermostat> | 8 – 39 | °C | |
| 32 | Indoor unit-Intake air temperature (Unit No. 1) <Heat mode-4-deg correction> | 8 – 39 | °C | "0" is displayed if the target unit is not present. |
| 33 | Indoor unit-Intake air temperature (Unit No. 2) <Heat mode-4-deg correction> | 8 – 39 | °C | ↑ |
| 34 | Indoor unit-Intake air temperature (Unit No. 3) <Heat mode-4-deg correction> | 8 – 39 | °C | ↑ |
| 35 | Indoor unit-Intake air temperature (Unit No. 4) <Heat mode-4-deg correction> | 8 – 39 | °C | ↑ |
| 36 | | | | |
| 37 | Indoor unit - Liquid pipe temperature (Unit No. 1) | -39 – 88 | °C | "0" is displayed if the target unit is not present. |
| 38 | Indoor unit - Liquid pipe temperature (Unit No. 2) | -39 – 88 | °C | ↑ |
| 39 | Indoor unit - Liquid pipe temperature (Unit No. 3) | -39 – 88 | °C | ↑ |
| 40 | Indoor unit - Liquid pipe temperature (Unit No. 4) | -39 – 88 | °C | ↑ |
| 41 | | | | |
| 42 | Indoor unit-Cond./Eva. pipe temperature (Unit No. 1) | -39 – 88 | °C | "0" is displayed if the target unit is not present. |
| 43 | Indoor unit-Cond./Eva. pipe temperature (Unit No. 2) | -39 – 88 | °C | ↑ |
| 44 | Indoor unit-Cond./Eva. pipe temperature (Unit No. 3) | -39 – 88 | °C | ↑ |
| 45 | Indoor unit-Cond./Eva. pipe temperature (Unit No. 4) | -39 – 88 | °C | ↑ |
| 46 | | | | |
| 47 | | | | |
| 48 | Thermostat ON operating time | 0 – 999 | Minutes | |
| 49 | Test run elapsed time | 0 – 120 | Minutes | ← Not possible to activate maintenance mode during the test run. |

| Request code | Request content | Description (Display range) | Unit | Remarks |
|--------------|--|--|------|---------|
| 50 | Indoor unit-Control state | Refer to 2-1.Detail Contents in Request Code. | – | |
| 51 | Outdoor unit-Control state | Refer to 2-1.Detail Contents in Request Code. | – | |
| 52 | Compressor-Frequency control state | Refer to 2-1.Detail Contents in Request Code. | – | |
| 53 | Outdoor unit-Fan control state | Refer to 2-1.Detail Contents in Request Code. | – | |
| 54 | Actuator output state | Refer to 2-1.Detail Contents in Request Code. | – | |
| 55 | Error content (U9) | Refer to 2-1.Detail Contents in Request Code. | – | |
| 56 | | | | |
| 57 | | | | |
| 58 | | | | |
| 59 | | | | |
| 60 | Signal transmission demand capacity | 0 – 255 | % | |
| 61 | Contact demand capacity | Refer to 2-1.Detail Contents in Request Code. | – | |
| 62 | External input state (silent mode, etc.) | Refer to 2-1.Detail Contents in Request Code. | – | |
| 63 | | | | |
| 64 | | | | |
| 65 | | | | |
| 66 | | | | |
| 67 | | | | |
| 68 | | | | |
| 69 | | | | |
| 70 | Outdoor unit-Capacity setting display | Refer to 2-1.Detail Contents in Request Code. | – | |
| 71 | Outdoor unit-Setting information | Refer to 2-1.Detail Contents in Request Code. | – | |
| 72 | | | | |
| 73 | Outdoor unit-SW1 setting information | Refer to 2-1.Detail Contents in Request Code. | – | |
| 74 | Outdoor unit-SW2 setting information | Refer to 2-1.Detail Contents in Request Code. | – | |
| 75 | | | | |
| 76 | Outdoor unit-SW4 setting information | Refer to 2-1.Detail Contents in Request Code. | – | |
| 77 | Outdoor unit-SW5 setting information | Refer to 2-1.Detail Contents in Request Code. | – | |
| 78 | Outdoor unit-SW6 setting information | Refer to 2-1.Detail Contents in Request Code. | – | |
| 79 | Outdoor unit-SW7 setting information | Refer to 2-1.Detail Contents in Request Code. | – | |
| 80 | Outdoor unit-SW8 setting information | Refer to 2-1.Detail Contents in Request Code. | – | |
| 81 | Outdoor unit-SW9 setting information | Refer to 2-1.Detail Contents in Request Code. | – | |
| 82 | Outdoor unit-SW10 setting information | Refer to 2-1.Detail Contents in Request Code. | – | |
| 83 | | | | |
| 84 | M-NET adapter connection (presence/absence) | "0000": Not connected "0001": Connected | – | |
| 85 | | | | |
| 86 | | | | |
| 87 | | | | |
| 88 | | | | |
| 89 | Display of execution of replace/wash operation | "0000": Not washed "0001": Washed | – | |
| 90 | Outdoor unit-Microcomputer version information | Examples) Ver 5.01 → "0501" | Ver | |
| 91 | Outdoor unit-Microcomputer version information (sub No.) | Auxiliary information (displayed after version information) Examples) Ver 5.01 A000 → "A000" | – | |
| 92 | | | | |
| 93 | | | | |
| 94 | | | | |
| 95 | | | | |
| 96 | | | | |
| 97 | | | | |
| 98 | | | | |
| 99 | | | | |
| 100 | Outdoor unit - Error postponement history 1 (latest) | Displays postponement code. (" - " is displayed if no postponement code is present) | Code | |
| 101 | Outdoor unit - Error postponement history 2 (previous) | Displays postponement code. (" - " is displayed if no postponement code is present) | Code | |
| 102 | Outdoor unit - Error postponement history 3 (last but one) | Displays postponement code. (" - " is displayed if no postponement code is present) | Code | |

| Request code | Request content | Description (Display range) | Unit | Remarks |
|--------------|--|--|------------------|--|
| 103 | Error history 1 (latest) | Displays error history. ("-" is displayed if no history is present.) | Code | |
| 104 | Error history 2 (second to last) | Displays error history. ("-" is displayed if no history is present.) | Code | |
| 105 | Error history 3 (third to last) | Displays error history. ("-" is displayed if no history is present.) | Code | |
| 106 | Abnormal thermistor display (TH3/TH6/TH7/TH8) | 3 : TH3 6 : TH6 7 : TH7 8 : TH8 0 : No thermistor error | Sensor number | |
| 107 | Operation mode at time of error | Displayed in the same way as request code "0". | - | |
| 108 | Compressor-Operating current at time of error | 0 – 50 | A | |
| 109 | Compressor-Accumulated operating time at time of error | 0 – 9999 | 10 hours | |
| 110 | Compressor-Number of operation times at time of error | 0 – 9999 | 100 times | |
| 111 | Discharge temperature at time of error | 3 – 217 | ℃ | |
| 112 | Outdoor unit - Liquid pipe 1 temperature (TH3) at time of error | -40 – 90 | ℃ | |
| 113 | Outdoor unit - Liquid pipe 2 temperature at time of error | -40 – 90 | ℃ | |
| 114 | Outdoor unit-2-phase pipe temperature (TH6) at time of error | -39 – 88 | ℃ | |
| 115 | | | | |
| 116 | Outdoor unit-Outside air temperature (TH7) at time of error | -39 – 88 | ℃ | |
| 117 | Outdoor unit-Heatsink temperature (TH8) at time of error | -40 – 200 | ℃ | |
| 118 | Discharge superheat (SHd) at time of error | 0 – 255 | ℃ | |
| 119 | Sub-cool (SC) at time of error | 0 – 130 | ℃ | |
| 120 | Compressor-Operating frequency at time of error | 0 – 255 | Hz | |
| 121 | Outdoor unit at time of error • Fan output step | 0 – 10 | Step | |
| 122 | Outdoor unit at time of error • Fan 1 speed (Only for air conditioners with DC fan) | 0 – 9999 | rpm | |
| 123 | Outdoor unit at time of error • Fan 2 speed (Only for air conditioners with DC fan) | 0 – 9999 | rpm | "0" is displayed if the air conditioner is a single-fan type. |
| 124 | | | | |
| 125 | LEV (A) opening at time of error | 0 – 500 | Pulses | |
| 126 | LEV (B) opening at time of error | 0 – 500 | Pulses | |
| 127 | | | | |
| 128 | | | | |
| 129 | | | | |
| 130 | Thermostat ON time until operation stops due to error | 0 – 999 | Minutes | |
| 131 | | | | |
| 132 | Indoor - Liquid pipe temperature at time of error | -39 – 88 | ℃ | Average value of all indoor units is displayed if the air conditioner consists of two or more indoor units (twin, triple, quad). |
| 133 | Indoor-2-phase pipe temperature at time of error | -39 – 88 | ℃ | Average value of all indoor units is displayed if the air conditioner consists of two or more indoor units (twin, triple, quad). |
| 134 | Indoor at time of error • Intake air temperature <Thermostat judge temperature> | -39 – 88 | ℃ | |
| 135 | | | | |
| 136 | | | | |
| 137 | | | | |
| 138 | | | | |
| 139 | | | | |
| 140 | | | | |
| ~ | | | | |
| 146 | | | | |
| 147 | | | | |
| 148 | | | | |
| 149 | | | | |
| 150 | Indoor-Actual intake air temperature | -39 – 88 | ℃ | |
| 151 | Indoor - Liquid pipe temperature | -39 – 88 | ℃ | |
| 152 | Indoor-2-phase pipe temperature | -39 – 88 | ℃ | |

| Request code | Request content | Description (Display range) | Unit | Remarks |
|--------------|---|---|----------|---------------------------------------|
| 153 | | | | |
| 154 | Indoor-Fan operating time (After filter is reset) | 0 – 9999 | 1 hour | |
| 155 | Indoor-Total operating time (Fan motor ON time) | 0 – 9999 | 10 hours | |
| 156 | | | | |
| 157 | Indoor fan output value (Sj value) | 0 – 255 Fan control data | – | For indoor fan phase control |
| 158 | Indoor fan output value (Pulsation ON/OFF) | "00 *** ****" indicates fan control data. | – | For indoor fan pulsation control |
| 159 | Indoor fan output value (duty value) | "00 *** ****" indicates fan control data. | – | For indoor DC brushless motor control |
| 160 | | | | |
| 161 | | | | |
| 162 | Indoor unit-Model setting information | Refer to 2-1. Detail Contents in Request Code. | – | |
| 163 | Indoor unit-Capacity setting information | Refer to 2-1. Detail Contents in Request Code. | – | |
| 164 | Indoor unit-SW3 information | Undefined | – | |
| 165 | Wireless pair No. (indoor control board side) setting | Refer to 2-1. Detail Contents in Request Code. | – | |
| 166 | Indoor unit-SW5 information | Undefined | – | |
| 167 | | | | |
| ~ | | | | |
| 189 | | | | |
| 190 | Indoor unit-Microcomputer version information | Examples) Ver 5.01 → "0501" | Ver | |
| 191 | Indoor unit-Microcomputer version information (sub No.) | Auxiliary information (displayed after version information) Examples) Ver 5.01 A000 → "A000" | – | |
| 192 | | | | |
| ~ | | | | |
| 764 | | | | |
| 765 | Stable operation (Heat mode) | This request code is not provided to collect data. It is used to fix the operation state. | | |
| 766 | Stable operation (Cool mode) | This request code is not provided to collect data. It is used to fix the operation state. | | |
| 767 | Stable operation cancellation | This request code is not provided to collect data. It is used to cancel the operation state that has been fixed by request codes "765" and "766". | | |

2-1. Detail Contents in Request Code

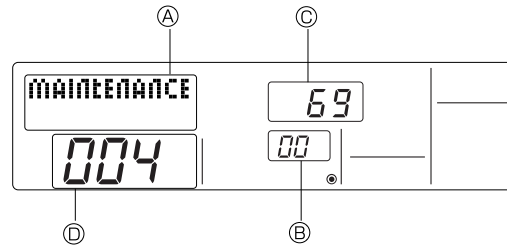

[Example) Request code "004"
Discharge temperature 69°C
Refrigerant address "00"]

B: Refrigerant address
C: Data display area
D: Request code display area

[Operation state] (Request code "0")

Data display

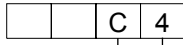

Relay output state
Operation mode

Operation mode

| Display | Operation mode |
|---------|----------------|
| 0 | STOP • FAN |
| C | COOL • DRY |
| H | HEAT |
| d | Defrost |

Relay output state

| Display | Power currently supplied to compressor | Compressor | Four-way valve | Solenoid valve |
|---------|--|------------|----------------|----------------|
| 0 | — | — | — | — |
| 1 | | | | ON |
| 2 | | | ON | |
| 3 | | | ON | ON |
| 4 | | ON | | |
| 5 | | ON | | ON |
| 6 | | ON | ON | |
| 7 | | ON | ON | ON |
| 8 | ON | | | |
| A | ON | | ON | |

[Indoor unit – Control state] (Request code : "50")

Data display

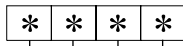

Unit No. 4 state
Unit No. 3 state
Unit No. 2 state
Unit No. 1 state

| Display | State |
|---------|------------------------------------|
| 0 | Normal |
| 1 | Preparing for heat operation. |
| 2 | — |
| 3 | — |
| 4 | Heater is ON. |
| 5 | Anti-freeze protection is ON. |
| 6 | Overheat protection is ON. |
| 7 | Requesting compressor to turn OFF. |
| F | There are no corresponding units. |

[Outdoor unit – Control state] (Request code "51")

| Data display | State |
|--------------|-------------------------------|
| 0 0 0 0 | Normal |
| 0 0 0 1 | Preparing for heat operation. |
| 0 0 0 2 | Defrost |

[Compressor – Frequency control state] (Request code "52")

Data display

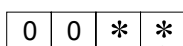

Frequency control state ②
Frequency control state ①

Frequency control state ①

| Display | Current limit control |
|---------|--|
| 0 | No current limit |
| 1 | Primary current limit control is ON. |
| 2 | Secondary current limit control is ON. |

Frequency control state ②

| Display | Discharge temperature overheat prevention | Condensation temperature overheat prevention | Anti-freeze protection control | Heat sink temperature overheat prevention |
|---------|---|--|--------------------------------|---|
| 0 | | | | |
| 1 | Controlled | | | |
| 2 | | Controlled | | |
| 3 | Controlled | Controlled | | |
| 4 | | | Controlled | |
| 5 | Controlled | | Controlled | |
| 6 | | Controlled | Controlled | |
| 7 | Controlled | Controlled | Controlled | |
| 8 | | | | Controlled |
| 9 | Controlled | | | Controlled |
| A | | Controlled | | Controlled |
| b | Controlled | Controlled | | Controlled |
| C | | | Controlled | Controlled |
| d | Controlled | | Controlled | Controlled |
| E | | Controlled | Controlled | Controlled |
| F | Controlled | Controlled | Controlled | Controlled |

[Fan control state] (Request code : "53")

Data display

| | | | |
|---|---|---|---|
| 0 | 0 | * | * |
|---|---|---|---|

— Fan step correction value by heat sink temperature overheat prevention control
 — Fan step correction value by cool condensation temperature overheat prevention control

| Display | Correction value |
|-----------|------------------|
| - (minus) | - 1 |
| 0 | 0 |
| 1 | +1 |
| 2 | +2 |

[Actuator output state] (Request code : "54")

Data display

| | | | |
|---|---|---|---|
| 0 | 0 | * | * |
|---|---|---|---|

— Actuator output state ①
 — Actuator output state ②

Actuator output state ①

| Display | SV1 | Four-way valve | Compressor | Compressor is warming up |
|---------|-----|----------------|------------|--------------------------|
| 0 | | | | |
| 1 | ON | | | |
| 2 | | ON | | |
| 3 | ON | ON | | |
| 4 | | | ON | |
| 5 | ON | | ON | |
| 6 | | ON | ON | |
| 7 | ON | ON | ON | |
| 8 | | | | ON |
| 9 | ON | | | ON |
| A | | ON | | ON |
| b | ON | ON | | ON |
| C | | | ON | ON |
| d | ON | | ON | ON |
| E | | ON | ON | ON |
| F | ON | ON | ON | ON |

Actuator output state ②

| Display | 52C | SV2 | SS |
|---------|-----|-----|----|
| 0 | | | |
| 1 | ON | | |
| 2 | | ON | |
| 3 | ON | ON | |
| 4 | | | ON |
| 5 | ON | | ON |
| 6 | | ON | ON |
| 7 | ON | ON | ON |

[Error content (U9)] (Request code : "55")

Data display

| | | | |
|---|---|---|---|
| 0 | 0 | * | * |
|---|---|---|---|

— Error content ①
 — Error content ②

Error content ①

● : Detected

| Display | Overvoltage error | Undervoltage error | L1-phase open error | Power synchronizing signal error |
|---------|-------------------|--------------------|---------------------|----------------------------------|
| 0 | | | | |
| 1 | ● | | | |
| 2 | | ● | | |
| 3 | ● | ● | | |
| 4 | | | ● | |
| 5 | ● | | ● | |
| 6 | | ● | ● | |
| 7 | ● | ● | ● | |
| 8 | | | | ● |
| 9 | ● | | | ● |
| A | | ● | | ● |
| b | ● | ● | | ● |
| C | | | ● | ● |
| d | ● | | ● | ● |
| E | | ● | ● | ● |
| F | ● | ● | ● | ● |

Error content ②

● : Detected

| Display | Converter Fo error | PAM error |
|---------|--------------------|-----------|
| 0 | | |
| 1 | ● | |
| 2 | | ● |
| 3 | ● | ● |

[Contact demand capacity] (Request code "61")

Data display

| | | | |
|---|---|---|---|
| 0 | 0 | 0 | * |
|---|---|---|---|

 Setting content

Setting content

| Display | Setting value | Setting | |
|---------|---------------|---------|-------|
| | | SW7-1 | SW7-2 |
| 0 | 0% | | |
| 1 | 50% | ON | |
| 2 | 75% | | ON |
| 3 | 100% | ON | ON |

[External input state] (Request code "62")

Data display

| | | | |
|---|---|---|---|
| 0 | 0 | 0 | * |
|---|---|---|---|

 Input state

Input state

● : Input present

| Display | Contact demand input | Silent mode input | Spare 1 input | Spare 2 input |
|---------|----------------------|-------------------|---------------|---------------|
| 0 | | | | |
| 1 | ● | | | |
| 2 | | ● | | |
| 3 | ● | ● | | |
| 4 | | | ● | |
| 5 | ● | | ● | |
| 6 | | ● | ● | |
| 7 | ● | ● | ● | |
| 8 | | | | ● |
| 9 | ● | | | ● |
| A | | ● | | ● |
| b | ● | ● | | ● |
| C | | | ● | ● |
| d | ● | | ● | ● |
| E | | ● | ● | ● |
| F | ● | ● | ● | ● |

[Outdoor unit –Capacity setting display] (Request code : "70")

| Data display | Capacity |
|--------------|----------|
| 9 | 35 |
| 10 | 50 |
| 11 | 60 |
| 14 | 71 |
| 20 | 100 |
| 25 | 125 |
| 28 | 140 |
| 40 | 170/200 |
| 50 | 250 |

[Outdoor unit – Setting information] (Request code "71")

Data display

| | | | |
|---|---|---|---|
| 0 | 0 | * | * |
|---|---|---|---|

 Setting information ①
Setting information ②

Setting information ①

| Display | Defrost mode |
|---------|-------------------|
| 0 | Standard |
| 1 | For high humidity |

Setting information ②

| Display | Single-/ three-phase | Heat pump/ cooling only |
|---------|----------------------|-------------------------|
| 0 | Single-phase | Heat pump |
| 1 | | Cooling only |
| 2 | Three-phase | Heat pump |
| 3 | | Cooling only |

[Outdoor unit switch setting display (SW1 to SW10, except SW3)] Request codes: 73 to 82

0: Switch OFF 1: Switch ON

| SW1, SW2, SW6, SW7 | | | | | | Data display |
|--------------------|---|---|---|---|---|--------------|
| 1 | 2 | 3 | 4 | 5 | 6 | |
| 0 | 0 | 0 | 0 | 0 | 0 | 00 00 |
| 1 | 0 | 0 | 0 | 0 | 0 | 00 01 |
| 0 | 1 | 0 | 0 | 0 | 0 | 00 02 |
| 1 | 1 | 0 | 0 | 0 | 0 | 00 03 |
| 0 | 0 | 1 | 0 | 0 | 0 | 00 04 |
| 1 | 0 | 1 | 0 | 0 | 0 | 00 05 |
| 0 | 1 | 1 | 0 | 0 | 0 | 00 06 |
| 1 | 1 | 1 | 0 | 0 | 0 | 00 07 |
| 0 | 0 | 0 | 1 | 0 | 0 | 00 08 |
| 1 | 0 | 0 | 1 | 0 | 0 | 00 09 |
| 0 | 1 | 0 | 1 | 0 | 0 | 00 0A |
| 1 | 1 | 0 | 1 | 0 | 0 | 00 0b |
| 0 | 0 | 1 | 1 | 0 | 0 | 00 0C |
| 1 | 0 | 1 | 1 | 0 | 0 | 00 0d |
| 0 | 1 | 1 | 1 | 0 | 0 | 00 0E |
| 1 | 1 | 1 | 1 | 0 | 0 | 00 0F |
| 0 | 0 | 0 | 0 | 1 | 0 | 00 10 |
| 1 | 0 | 0 | 0 | 1 | 0 | 00 11 |
| 0 | 1 | 0 | 0 | 1 | 0 | 00 12 |
| 1 | 1 | 0 | 0 | 1 | 0 | 00 13 |
| 0 | 0 | 1 | 0 | 1 | 0 | 00 14 |
| 1 | 0 | 1 | 0 | 1 | 0 | 00 15 |
| 0 | 1 | 1 | 0 | 1 | 0 | 00 16 |
| 1 | 1 | 1 | 0 | 1 | 0 | 00 17 |
| 0 | 0 | 0 | 1 | 1 | 0 | 00 18 |
| 1 | 0 | 0 | 1 | 1 | 0 | 00 19 |
| 0 | 1 | 0 | 1 | 1 | 0 | 00 1A |
| 1 | 1 | 0 | 1 | 1 | 0 | 00 1B |
| 0 | 0 | 1 | 1 | 1 | 0 | 00 1C |
| 1 | 0 | 1 | 1 | 1 | 0 | 00 1D |
| 0 | 1 | 1 | 1 | 1 | 0 | 00 1E |
| 1 | 1 | 1 | 1 | 1 | 0 | 00 1F |
| 0 | 0 | 0 | 0 | 0 | 1 | 00 20 |
| 1 | 0 | 0 | 0 | 0 | 1 | 00 21 |
| 0 | 1 | 0 | 0 | 0 | 1 | 00 22 |
| 1 | 1 | 0 | 0 | 0 | 1 | 00 23 |
| 0 | 0 | 1 | 0 | 0 | 1 | 00 24 |
| 1 | 0 | 1 | 0 | 0 | 1 | 00 25 |
| 0 | 1 | 1 | 0 | 0 | 1 | 00 26 |
| 1 | 1 | 1 | 0 | 0 | 1 | 00 27 |
| 0 | 0 | 0 | 1 | 0 | 1 | 00 28 |
| 1 | 0 | 0 | 1 | 0 | 1 | 00 29 |
| 0 | 1 | 0 | 1 | 0 | 1 | 00 2A |
| 1 | 1 | 0 | 1 | 0 | 1 | 00 2B |
| 0 | 0 | 1 | 1 | 0 | 1 | 00 2C |
| 1 | 0 | 1 | 1 | 0 | 1 | 00 2D |
| 0 | 1 | 1 | 1 | 0 | 1 | 00 2E |
| 1 | 1 | 1 | 1 | 0 | 1 | 00 2F |
| 0 | 0 | 0 | 0 | 1 | 1 | 00 30 |
| 1 | 0 | 0 | 0 | 1 | 1 | 00 31 |
| 0 | 1 | 0 | 0 | 1 | 1 | 00 32 |
| 1 | 1 | 0 | 0 | 1 | 1 | 00 33 |
| 0 | 0 | 1 | 0 | 1 | 1 | 00 34 |
| 1 | 0 | 1 | 0 | 1 | 1 | 00 35 |
| 0 | 1 | 1 | 0 | 1 | 1 | 00 36 |
| 1 | 1 | 1 | 0 | 1 | 1 | 00 37 |
| 0 | 0 | 0 | 1 | 1 | 1 | 00 38 |
| 1 | 0 | 0 | 1 | 1 | 1 | 00 39 |
| 0 | 1 | 0 | 1 | 1 | 1 | 00 3A |
| 1 | 1 | 0 | 1 | 1 | 1 | 00 3B |
| 0 | 0 | 1 | 1 | 1 | 1 | 00 3C |
| 1 | 0 | 1 | 1 | 1 | 1 | 00 3D |
| 0 | 1 | 1 | 1 | 1 | 1 | 00 3E |
| 1 | 1 | 1 | 1 | 1 | 1 | 00 3F |

0: Switch OFF 1: Switch ON

| SW5 | | | | Data display |
|-----|---|---|---|--------------|
| 1 | 2 | 3 | 4 | |
| 0 | 0 | 0 | 0 | 00 00 |
| 1 | 0 | 0 | 0 | 00 01 |
| 0 | 1 | 0 | 0 | 00 02 |
| 1 | 1 | 0 | 0 | 00 03 |
| 0 | 0 | 1 | 0 | 00 04 |
| 1 | 0 | 1 | 0 | 00 05 |
| 0 | 1 | 1 | 0 | 00 06 |
| 1 | 1 | 1 | 0 | 00 07 |
| 0 | 0 | 0 | 1 | 00 08 |
| 1 | 0 | 0 | 1 | 00 09 |
| 0 | 1 | 0 | 1 | 00 0A |
| 1 | 1 | 0 | 1 | 00 0b |
| 0 | 0 | 1 | 1 | 00 0C |
| 1 | 0 | 1 | 1 | 00 0d |
| 0 | 1 | 1 | 1 | 00 0E |
| 1 | 1 | 1 | 1 | 00 0F |

0: Switch OFF 1: Switch ON

| SW8 | | | Data display |
|-----|---|---|--------------|
| 1 | 2 | 3 | |
| 0 | 0 | 0 | 00 00 |
| 1 | 0 | 0 | 00 01 |
| 0 | 1 | 0 | 00 02 |
| 1 | 1 | 0 | 00 03 |
| 0 | 0 | 1 | 00 04 |
| 1 | 0 | 1 | 00 05 |
| 0 | 1 | 1 | 00 06 |
| 1 | 1 | 1 | 00 07 |

0: Switch OFF 1: Switch ON

| SW4, SW9, SW10 | | Data display |
|----------------|---|--------------|
| 1 | 2 | |
| 0 | 0 | 00 00 |
| 1 | 0 | 00 01 |
| 0 | 1 | 00 02 |
| 1 | 1 | 00 03 |

[Indoor unit – Model setting information] (Request code : 162)

Data display

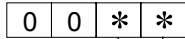

See the table on the right.

| Display | Model setting state | Display | Model setting state |
|---------|------------------------------|---------|---------------------------------------|
| 00 | PSA-RP•GA, PSH-PGAH | 20 | |
| 01 | | 21 | PKA-RP•FAL(2), PKH-P•FALH |
| 02 | PEAD-RP•EA(2)/GA, PEHD-P•EAH | 22 | PCA-RP•GA(2), PCH-P•GAH, PLA-RP•BA(2) |
| 03 | SEZ-KA•VA | 23 | |
| 04 | | 24 | |
| 05 | SLZ-KA•VA(L) | 25 | |
| 06 | PCA-RP•HA | 26 | |
| 07 | | 27 | |
| 08 | | 28 | |
| 09 | PEA-RP400/500GA | 29 | |
| 0A | | 2A | |
| 0b | PEA-RP200/250GA | 2b | PKA-RP•GAL, PKH-P•GALH |
| 0C | | 2C | |
| 0d | | 2d | |
| 0E | | 2E | |
| 0F | | 2F | PLA-RP•AA |
| 10 | | 30 | |
| 11 | PEA-RP•EA | 31 | PLH-P•AAH |
| 12 | MEXZ-GA•VA(L) | 32 | |
| 13 | | 33 | |
| 14 | | 34 | |
| 15 | | 35 | |
| 16 | | 36 | PLA-RP•AA2 |
| 17 | | 37 | |
| 18 | | 38 | |
| 19 | | 39 | |
| 1A | | 3A | |
| 1b | | 3b | |
| 1C | | 3C | |
| 1d | | 3d | |
| 1E | | 3E | |
| 1F | | 3F | |

[Indoor unit – Capacity setting information] (Request code 163)

Data display

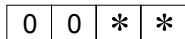

See the table on the right.

| Display | Capacity setting state | Display | Capacity setting state |
|---------|------------------------|---------|------------------------|
| 00 | 12 | 10 | 112 |
| 01 | 16 | 11 | 125 |
| 02 | 22 | 12 | 140 |
| 03 | 25 | 13 | |
| 04 | 28 | 14 | |
| 05 | 32 | 15 | |
| 06 | 35, 36 | 16 | |
| 07 | 40 | 17 | |
| 08 | 45 | 18 | |
| 09 | 50 | 19 | |
| 0A | 56 | 1A | |
| 0b | 63 | 1b | |
| 0C | 71 | 1C | |
| 0d | 80 | 1d | |
| 0E | 90 | 1E | |
| 0F | 100 | 1F | |

[Wireless pair No. (indoor control board side) setting] (Request code 165)

Data display

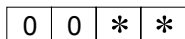



See the table on the right.

| Display | Pair No. setting state |
|---------|-----------------------------|
| 00 | No. 0 |
| 01 | No. 1 J41 disconnected |
| 02 | No. 2 J42 disconnected |
| 03 | No. 3 J41, J42 disconnected |

X. System Control (for Mr. SLIM)

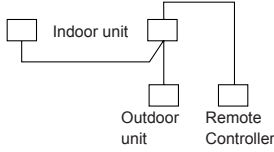
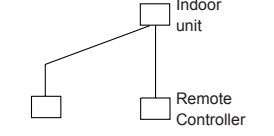
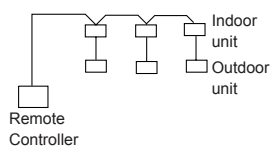
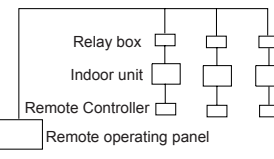
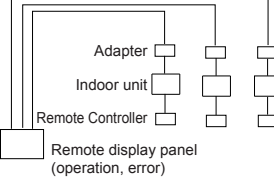
■ VARIETY OF SYSTEM FUNCTION

| System Name | System Diagram | Features | Parts Required in Addition to Standard System Components (Indoor/Outdoor Units, Remote Controller) |
|---|--|--|--|
| A.Remote controller operation (Standard) |  | There are 2 types of remote controllers: wired type and wireless type. Simultaneous twin, triple and quad units are counted as 1 unit, and the indoor units are started or stopped simultaneously. | — |
| B.Remote controller operation Use of 2 controllers enables operation of the air conditioner both from a distance and nearby. |  * One of the wired remote controllers must be set as a sub remote controller. | Up to 2 remote controllers can be connected to one group. Simultaneous twin, triple and quad units are counted as 1 unit. Operation control by the latest command (last entered priority) Wired and wireless remote controllers can be combined as a pair. | Wired remote controller (additional) (PAR-21MAA) For PKA type, use remote controller (PAR-21MAAT-E) * For models equipped with a terminal block. |
| C.Group control operation Use of 1 remote controller to control multiple air conditioners with the same settings simultaneously. * Outdoor unit's refrigerant address needs to be set. |  | One group can consist of up to 16 indoor units, and they can be started sequentially by connecting the remote controller to them and assigning an address to each outdoor unit. Simultaneous twin, triple and quad units are counted as 1 unit. All the units belonging to the same group are operated in the same mode, but thermostats can be turned ON/OFF individually for each outdoor unit. Up to 2 remote controllers can be connected. | For PKA type, use remote controller (PAR-21MAAT-E) * For models equipped with a terminal block. |
| D.Remote/local combined control operation Allows start/stop of the air conditioner from a distance, and prohibits/permits start/stop from remote controllers. |  | All the air conditioners can be turned ON/OFF collectively from a distance. Operation can be switched between the remote operating panel and local controller. Operations (e.g., temperature adjustment, airflow, airflow direction) except for start/stop operations can be performed even if operations from the local remote controller are prohibited. In the case of simultaneous twin, triple, quad units, connect the controller to one indoor unit only. If connected to 2 or more indoor units, an error may occur.(operation stop) Control by an external timer is possible by connecting it. | Remote ON/OFF adapter (PAC-SE55RA-E) Relay box (Part to be provided at your site) Remote operating panel (Part to be provided at your site) |
| E.Operation by external signal | — | Use of optional "remote ON/OFF adapter" enables remote control via relay. (Level signal) | Remote ON/OFF adapter (PAC-SE55RA-E) |
| F.Control by external signal and remote display Enables you to display the operation state and control start/stop from a distance. |  | Extraction of non-voltage contact output Use of optional "remote operation adapter" and "remote display panel" (Part to be provided at your site) provides non-voltage contact outputs of signals (operation, error) and operation/stop input function. | Remote operation adapter (PAC-SF40RM-E) Remote display panel (Part to be provided at your site) |
| | | Extraction of DC12 V contact output Use of optional "Multiple remote controller adapter" and "remote display panel" (Part to be provided at your site) provides DC12 V contact outputs of signals (operation, error) and operation/stop input function. | Multiple remote controller adapter (PAC-SA88HA) Remote display panel (Part to be provided at your site) |

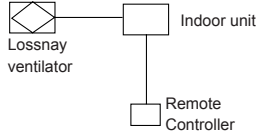
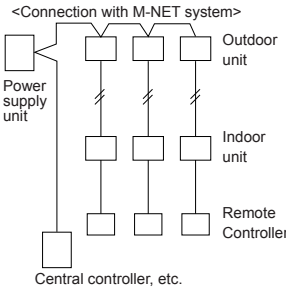
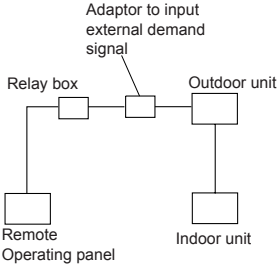
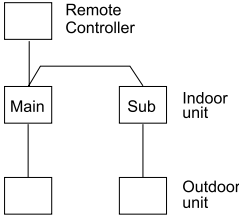
| System Name | System Diagram | Features | Parts Required in Addition to Standard System Components (Indoor/Outdoor Units, Remote Controller) |
|---|--|--|--|
| <p>G. Timer operation</p> <p>Enables control of start and stop.</p> <p>* For control by external timer, refer to Remote/local combined control operation*.</p> |  | <ul style="list-style-type: none"> Weekly timer: In addition to ON/OFF, up to 8 temperature patterns can be set for each day of the week. * Only one timer can be selected; the auto off, simple and weekly timers cannot be combined. Simple timer: Start and stop operations can each be performed once within 72 hours (can be set in 1-hour increments). Auto off timer: Operation is stopped when the preset time elapses following the start of operation. The time can be set from 30 minutes to 4 hours in 30-minute increments. * Only one timer can be selected; the simple and auto off timers cannot be combined. | <p>MA Remote controller (PAR-21MAA)</p> |
| <p>H. Interlock operation with peripheral equipment</p> <p>Enables control of Mitsubishi Lossnay ventilator by remote controller.</p> |  | <ul style="list-style-type: none"> Connecting a Lossnay ventilator and an indoor unit enables control of interlock/solo ventilation operation and airflow. (Only the microcomputer type Lossnay ventilator can be used.) | |
| <p>I. Central control</p> | <p><Connection with M-NET system></p>  | <ul style="list-style-type: none"> Connecting the M-NET connection adapter to outdoor unit enables connection of MELANS system controller (for M-NET). When using A-control operation, the number of indoor units in a MELANS system is limited to the number of outdoor units. (Simultaneous twin, triple and quad units are counted as 1 unit.) Number of controlled outdoor units Central controller: 50 units Group remote controller (PAC-SC30GR): 16 units | <p>M-NET adapter (Option PARTS) Central controller (G-50A) Group remote controller (PAC-SC30GR), etc.</p> |
| <p>J. Demand control</p> |  | <ul style="list-style-type: none"> Demand control is available by external input. In this mode, power consumption is decreased within the range of usual 0-100%. | <p>Adapter to input external demand signals. (PAC-SC36NA)</p> <p>Relay box (Part to be provided at your site)</p> <p>Remote operating panel (Part to be provided at your site)</p> |
| <p>K. Rotation</p> |  | <ul style="list-style-type: none"> Rotation Main and sub unit operate alternately according to the interval of rotation setting. Back-up When abnormality occurs while operation, it changes into operating the backup unit, and operation is continued. 2nd stage cut-in Number of operating units is determined according to the room temperature and set point. When room temperature becomes higher than set point, standby unit starts. (2 units operation) When room temperature falls below set point -4°C, standby unit stops. (1 unit operation) | <ul style="list-style-type: none"> This function is available when only 2 indoor units are connected to each PUHZ type outdoor unit. <p>Application model Indoor unit PLA-RP · BA2/BA#2.UK PCA-RP · GA(2)#1/HA#1 PKA-RP · GAL#1/FAL(2)#1 PSA-RP · GA#1 PEAD-RP · EA(2)#1/GA#1</p> |

1. 1 Remote Controller (Standard) Operation

1-1 1 Wired Remote Controller

(OC: Outdoor unit IC: Indoor unit R: Remote controller (for wireless type: optical receiver adapter))

| Slim Air Conditioners System | | Standard 1:1 | Simultaneous Twin | Simultaneous Triple | Simultaneous Quad |
|---|---------------------------|--|-------------------|---------------------|-------------------|
| System diagram (Wired remote controller) | Outdoor unit OC | Indoor/Outdoor connection cable Remote controller cable | | | |
| | Indoor unit IC | | | | |
| | Wired remote controller R | | | | |

* Numbers given in () apply when power is supplied to the indoor and outdoor units separately.

(Reference)

- ① If simultaneous twin or triple or quad, connect the remote controller to any one of the indoor units. All functions of the indoor unit can be controlled even if different models (different types) are mixed.
- ② Do not use crossover wiring among indoor units with simultaneous twin, triple, quad units. (Prohibited item.)
- ③ Electrical wiring diagram

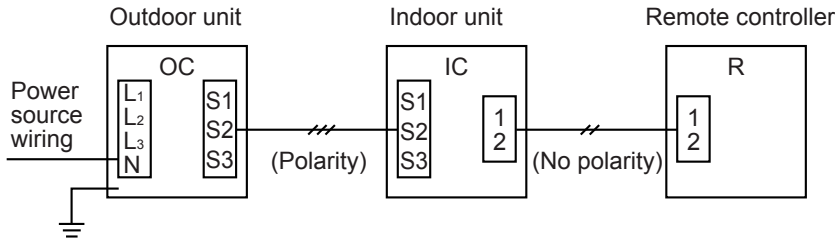

1-2 Wireless remote controller

| Slim Air Conditioners System | | Standard 1:1 | Simultaneous Twin | Simultaneous Triple | Simultaneous Quad |
|---|--|---------------------------------|-------------------|---------------------|-------------------|
| System diagram (Wireless remote controller receiver) | Outdoor unit OC | Indoor/Outdoor connection cable | | | |
| | Indoor unit IC | | | | |
| | Wireless remote controller receiver section R' | | | | |

* Numbers given in () apply when power is supplied to the indoor and outdoor units separately.

(Reference)

- ① If simultaneous twin or triple or quad, connect the remote controller to any one of the indoor units. All functions of the indoor unit can be controlled even if different models (different types) are mixed.
- ② Do not use crossover wiring among indoor units with simultaneous twin, triple, quad units. (Prohibited item.)
- ③ Electrical wiring diagram

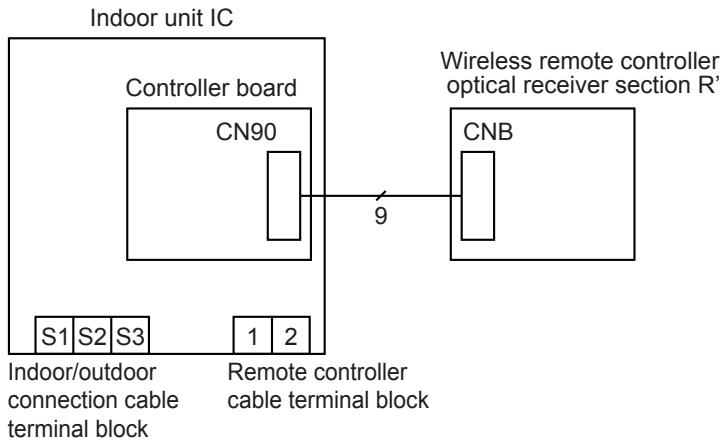

1-3 Wired Remote Controller or Wireless Remote Controller Receiver Built into Indoor Unit

[Floor type (wired remote controller)/4-way ceiling cassette type, ceiling suspended type, wall mounted type (wireless remote controller)]

| Slim Air Conditioner System | | Standard 1:1 | Simultaneous Twin | Simultaneous Triple | Simultaneous Quad |
|--|---------------------------------------|--------------|-------------------|---------------------|-------------------|
| System diagram (Wired remote controller or wireless remote controller receiver) | Outdoor unit OC | | | | |
| | Indoor unit IC | | | | |
| | Wired remote controller or receiver R | | | | |

* Numbers given in () apply when power is supplied to the indoor and outdoor units separately.

[Reference]

- For systems containing built-in wired remote controllers (or built-in wireless receiver adapters) and consisting of simultaneous twin, triple and quad units only, the installed remote controllers (or receiver adapters) must be connected without changing any settings. If the system consists of different models, keep only one of the remote controllers built into the indoor units, or remove all the remote controller cables and connect them to other models according to 1-1 or 1-2.
- Use the wired remote controllers without setting them as the main and sub controllers.

2. 2-remote Controller Operation

2-1 2 Wired Remote Controllers

(R: Wired remote controller)

| Slim Air Conditioner System | | Standard 1:1 | Simultaneous Twin |
|---|---------------------------|---------------------|-------------------|
| System diagram (Wired remote controller) | Outdoor unit OC | | |
| | Indoor unit IC | | |
| | Wired remote controller R | | |
| System diagram (Wired remote controller) | Outdoor unit OC | | |
| | Indoor unit IC | | |
| | Wired remote controller R | | |
| Slim Air Conditioner System | | Simultaneous Triple | Simultaneous Quad |
| System diagram (Wired remote controller) | Outdoor unit OC | | |
| | Indoor unit IC | | |
| | Wired remote controller R | | |
| System diagram (Wired remote controller) | Outdoor unit OC | | |
| | Indoor unit IC | | |
| | Wired remote controller R | | |

* Numbers given in () apply when power is supplied to the indoor and outdoor units separately.

[Reference]

- If simultaneous twin or triple or quad, connect the remote controller to any one of the indoor units. All functions of the indoor unit can be controlled even if different models (different types) are mixed.
- Do not use crossover wiring among indoor units with simultaneous twin, triple, quad units. (Prohibited item.)
- Set one of the remote controllers as the main controller (initial setting) and the other as the sub controller using the remote controller's function selection.

2-2 2 Wireless Remote Controllers

(R': Wireless remote controller receiver)

| Slim Air Conditioner System | | Standard 1:1 | Simultaneous Twin |
|---|--|--------------|-------------------|
| System diagram (Wireless remote controller receiver) | Outdoor unit OC | — | |
| | Indoor unit IC | | |
| | Wireless remote controller receiver section R' | | |

| Slim Air Conditioner System | | Simultaneous Triple | Simultaneous Quad |
|---|--|---------------------|-------------------|
| System diagram (Wireless remote controller receiver) | Outdoor unit OC | | |
| | Indoor unit IC | | |
| | Wireless remote controller receiver section R' | | |

* Numbers given in () apply when power is supplied to the indoor and outdoor units separately.

[Reference]

- ① If simultaneous twin or triple or quad, connect 2 wireless remote controller receivers (one each) to any 2 of the indoor units. All the functions of the indoor unit can be controlled even if different models (different types) are mixed.
- ② Do not use crossover wiring among indoor units with simultaneous twin, triple, quad units. (Prohibited item.)
- ③ In the case of "standard 1:1" connection, it is not possible to connect 2 remote controller receivers to the indoor units. However, with systems consisting of simultaneous twin or triple or quad units, it is possible to connect a remote controller receiver to 2 indoor units. In this case, all the pair numbers will be "0" (initial setting, no change necessary), and all the units will be turned ON/OFF simultaneously.
- ④ When using 2 or more wireless remote controllers, the display contents on the remote controllers may differ from the actual settings, since the operation mode last by any of the remote controllers will be effective.

2-3 1 Wired and 1 Wireless Remote Controller

(R: Wired remote controller, R': Wireless remote controller receiver)

| Slim Air Conditioner System | | Standard 1:1 | Simultaneous Twin |
|---|---------------------------------------|--------------|-------------------|
| System diagram (Wired remote controller and wireless remote controller receiver) | Outdoor unit OC | | |
| | Indoor unit IC | | |
| | Wired remote controller Receiver R-R' | | |

| Slim Air Conditioner System | | Simultaneous Triple | Simultaneous Quad |
|---|---------------------------------------|---------------------|-------------------|
| System diagram (Wired remote controller and wireless remote controller receiver) | Outdoor unit OC | | |
| | Indoor unit IC | | |
| | Wired remote controller Receiver R-R' | | |

* Numbers given in () apply when power is supplied to the indoor and outdoor units separately.

[Reference]

- ① If simultaneous twin or triple or quad, connect both the wired remote controller and wireless remote controller receiver to any one of the indoor units. All the functions of the indoor unit can be controlled even if different models (different types) are mixed.
- ② Do not use crossover wiring among indoor units with simultaneous twin, triple, quad units. (Prohibited item.)
- ③ When using 2 or more remote controllers, the display contents on the remote controllers may differ from the actual settings, since the operation mode last by any of the wireless remote controllers will be effective.

3. Group Control Operation (Collective Operation and Control of Multiple Refrigerant Systems (2 to 16))

- Multiple Mr.Slim air conditioners can be operated with the same settings (e.g., operation mode, preset temperature, etc.) by using 1 remote controller. Each outdoor unit can be turned ON/OFF individually by the intake sensor.
- Up to 16 refrigerant systems can be controlled as a group by 1 remote controller.
- A refrigerant address must be set for each outdoor unit. Addresses "0" to "15" can be set with no duplicates. Address "0" must be set for one of the outdoor units.

* In the case of simultaneous twin, triple and quad units, only 1 refrigerant system is used.

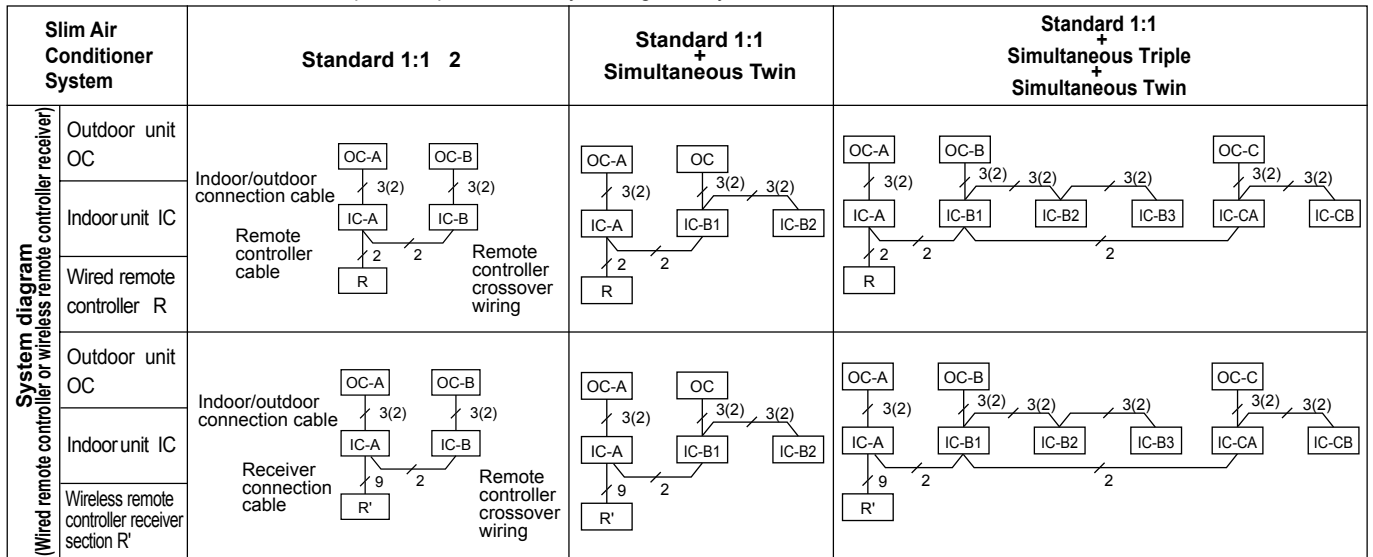

* Numbers given in () apply when power is supplied to the indoor and outdoor units separately.

[Reference]

- ① For 2-remote controller control, refer to "2.2-Remote Controller Operation". However, when using both wired and wireless remote controllers, receivers must be connected to indoor units that are connected by crossover wiring.
- ② Connect an indoor unit having the highest functions among the group to the outdoor unit assigned to refrigerant address "0". <Refer to the example given below> If indoor units with vanes are used with those without vanes, connect the outdoor unit to a unit with vanes.

Function specifications <Example>

| Item | | 4-way ceiling cassette | | | Ceiling suspended | Wall mounted | Floor mounted | Ceiling suspended (suitable for kitchen) | Ceiling concealed | | | | |
|-------------------------|----------------------|-------------------------|--------------|--------------|----------------------------|---------------------------|------------------------------|--|-------------------|-------------------------------------|--------------|--------------|-----------|
| | | PLA-RP.AA PLH-RP.AAH | PLA-RP.BA(2) | SLZ-KA.VA(L) | PCA-RP.GA(2) PCH-RP.GAH | PKA-RP.GAL PKH-RP.GALH | PKA-RP.FAL(2) PKH-RP.FALH | PSA-RP.GA PSH-RP.GAH | PCA-RP.HA | PEAD-RP.EA(2) /GA PEHD-RP.EAH | PEA-RP.EA(2) | SEZ-KA/KC.VA | SEZ-KD.VA |
| Fan | Number of fan speeds | 4 | 4+Auto | 3 | 4 | 4 | 2 | 2 | 2 | 2 | 2 | 2 | 3 |
| Up/down vane | Presence/absence | ○ | ○ | ○ | ○ | ○ | ○ | × | × | × | × | × | × |
| | Swing function | ○ | ○ | ○ | ○ | ○ | ○ | × | × | × | × | × | × |
| Left/right swing/louver | Presence/absence | × | × | × | × | × | ○ | × | × | × | × | × | × |
| Function order | | 1 | 1 | 2 | 1 | 1 | 3 | 4 | 6 | 6 | 6 | 6 | 5 |

- ③ In the case of multi type systems consisting of simultaneous twin, triple and quad units, the indoor units should not be connected by crossover wiring. (Prohibited)

Outdoor unit address setting

- For group control, an address must be set for each outdoor unit.
- To set addresses to outdoor units, use the DIP switch SW1 (3-6) provided on each outdoor control board (initial setting: all are set to "OFF").
- Address setting by SW1 is as follows.

| SW1 Function selection | Function | Operation by switch | |
|------------------------|-----------------------------|---|--------|
| | | ON | OFF |
| 1 | Forced defrosting | Start | Normal |
| 2 | Error history clear | Clear | Normal |
| 3 | Refrigerant address setting | Used to set outdoor unit addresses ("0" to "15"). | |
| 4 | ↑ | | |
| 5 | ↑ | | |
| 6 | ↑ | | |

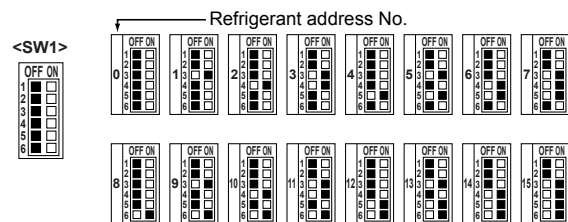

Factory setting: All switches are set to OFF (i.e., refrigerant address "0").

* Checking the outdoor unit refrigerant addresses

To find the location of an outdoor unit with a specific refrigerant address, specify the address in self-diagnosis mode. The outdoor unit will operate intermittently. (For details on using self-diagnosis mode.)

Group operation by multiple remote controllers

- Up to 2 remote controllers can be connected to each group. For details, refer to "2.2-REMOTE CONTROLLER OPERATION".

4. Rotation Function (and back-up function, 2nd stage cut-in function)

4-1. Operation

(1) Rotation function (and Back-up function)

• Outline of functions

- Main and sub units operate alternately according to the interval of rotation setting.
- ※ Main and sub unit should be set by refrigerant address. (Outdoor Dip switch setting)
 - Refrigerant address "00" → Main unit
 - Refrigerant address "01" → Sub unit
- When error occurs to one unit, another unit will start operation. (Back-up function)

• System constraint

- This function is available only by the grouping control system(INDOOR UNIT : OUTDOOR UNIT=1:1) of 2 refrigerant groups. (Refer to Fig. 1)
- Main indoor unit should be connected for wired remote controller and the transmission line(TB5) for main and sub unit should also be connected. (Refer to Fig. 1)
- (This function cannot be set by wireless remote controller.)
- Set refrigerant address of each unit. (Dip switch on the outdoor unit ... Refrigerant address 00/01)

Operation pattern

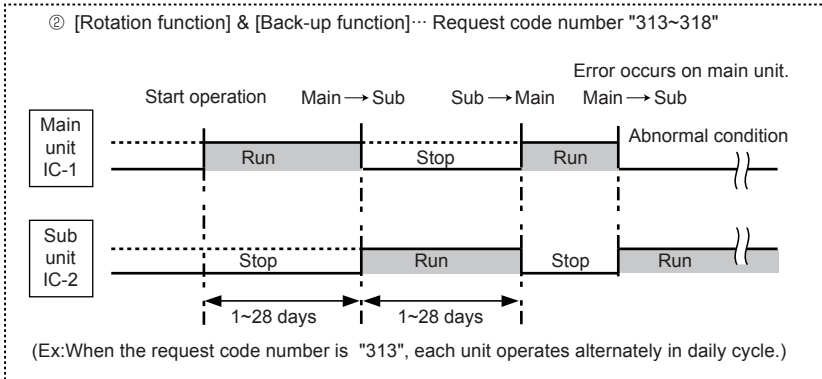
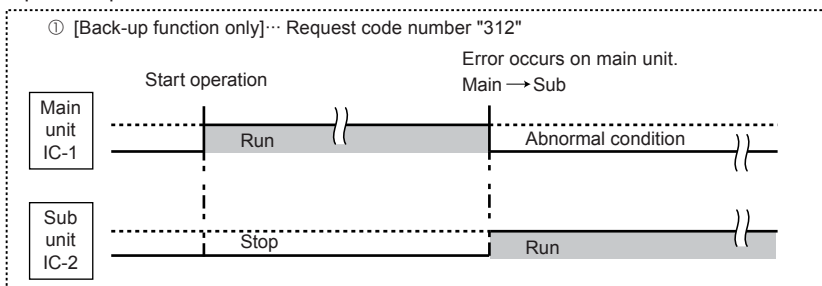
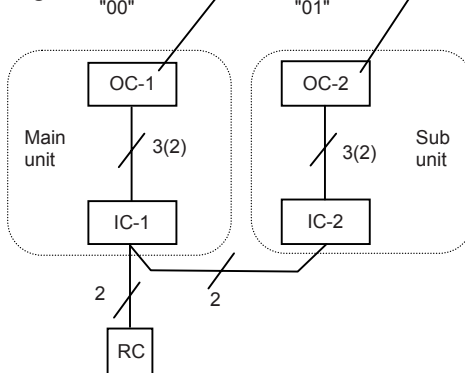

Fig. 1 Refrigerant address "00" Refrigerant address "01"



OC : Outdoor unit
IC : Indoor unit
RC : Wired remote controller

Note:

- When the unit is restarted to operate after turning off the power or OFF operation, the unit which was operating will start operation.
- To operate the main unit, refer to the 4-2. and set the request code No. which is not the same as the current one, and set again the former request code No.

(2) 2nd stage cut-in function

• Outline of functions

- When the 1st unit can NOT supply with sufficient capacity for exceptionally high-demand conditions and the actual room temperature reaches set point *, the 2nd unit starts operation in conjunction with the 1st unit.
- Once the actual room temperature goes down to 4degrees C below set point *, the 2nd unit stops operation automatically. (* set point = set temperature by R/C (remote controller) + 4, 6, 8°C (selectable))
- Number of operating units is determined according to the room temperature and set point.
- When room temperature becomes higher than set point, standby unit starts.(2 units operation)
- When room temperature falls below set point -4°C, standby unit stops.(1 unit operation)

• **System constraint**

· This function is available only in cooling mode.

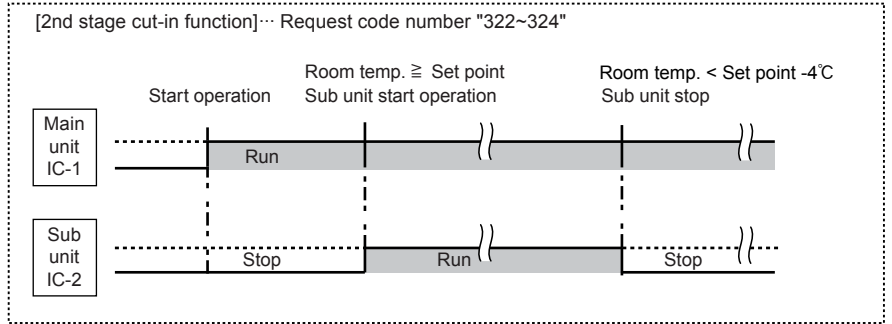
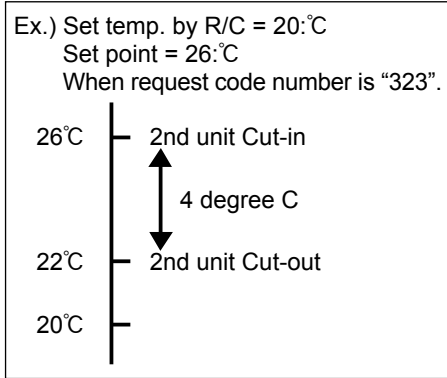

4-2. How to set rotation function(Back-up function, 2nd stage cut-in function)

You can set these functions by wired remote controller.(Maintenance monitor)

NOTICE

Both main and sub unit should be set in same setting.
 Every time replacing indoor controller board for servicing, the function should be set again.

(1) Request Code List

Rotation setting

| Setting No. (Request code) | Setting contents | Initial setting |
|-------------------------------|---|-----------------|
| No.1 (310) | Monitoring the request code of current setting. | |
| No.2 (311) | Rotation and Back-up OFF (Normal group control operation) | ☉ |
| No.3 (312) | Back-up function only | |
| No.4 (313) | Rotation ON (Alternating interval = 1day) and back up function | |
| No.5 (314) | Rotation ON (Alternating interval = 3day) and back up function | |
| No.6 (315) | Rotation ON (Alternating interval = 5day) and back up function | |
| No.7 (316) | Rotation ON (Alternating interval = 7day) and back up function | |
| No.8 (317) | Rotation ON (Alternating interval = 14day) and back up function | |
| No.9 (318) | Rotation ON (Alternating interval = 28day) and back up function | |

2nd stage cut-in setting

| Setting No. (Request code) | Setting contents | Initial setting |
|-------------------------------|--|-----------------|
| No.1 (320) | Monitoring the request code of current setting. | |
| No.2 (321) | Cut-in function OFF | ☉ |
| No.3 (322) | Cut-in Function ON(Set point = Set temp.+ 4°C(7.2°F)) | |
| No.4 (323) | Cut-in Function ON(Set point = Set temp.+ 6°C(10.8°F)) | |
| No.5 (324) | Cut-in Function ON(Set point = Set temp.+ 8°C(14.4°F)) | |

(2) Setting method of each function by wired remote controller

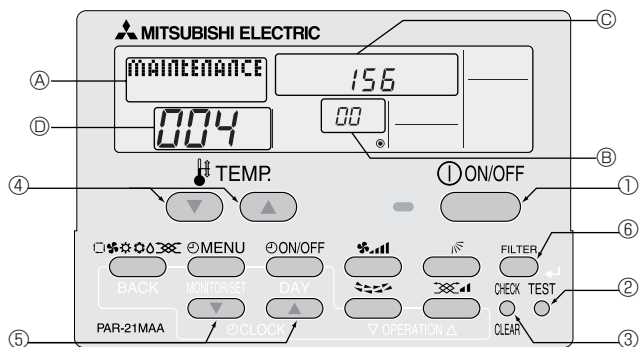

B: Refrigerant address
 C: Data display area
 D: Request code display area

1. Stop operation(①).
2. Press the **TEST** button (②) for 3 seconds so that [Maintenance mode] appears on the screen (A).
 After a while, [00] appears in the refrigerant address number display area.(at B)
3. Press the **CHECK** button (③) for 3 seconds to switch to [Maintenance monitor].
 Note) It is not possible to switch to [Maintenance monitor] during data request in maintenance mode (i.e., while "----" is blinking) since no buttons are operative.

[----] appears on the screen (D) when [Maintenance monitor] is activated.
 (The display (D) now allows you to set a request code No.)

4. Press the [TEMP (▽ and △)] buttons (④) to select the desired refrigerant address.



5. Press the [CLOCK (▽ and △)] buttons (⑤) to set the desired request code No. ("311~318", "321~324")
6. Press the **FILTER** button (⑥) to perform function setting.
 If above setting operations are done correctly, "Request code number" will appear in data display area.(C)
 [Example: When the "311" of "Request code number" is set, [311] appears on the screen.(C)]

[Reference]

You can check current "request code number" setting by setting the "request code number" ("310" or "320") and pressing the **FILTER** button.(⑥)
 [Example: When the current setting is "Setting No.2(Request code 311)", [311] appears on the screen.(C)]

7. To return to normal mode, press the **ON/OFF** button (①).

MEMO

A series of horizontal dotted lines for writing.

**CITY MULTI and Mr.SLIM
Air Conditioners**

**MA Remote Controller
PAR-21MAA**

 **MITSUBISHI ELECTRIC CORPORATION**
HEAD OFFICE: TOKYO BLDG., 2-7-3, MARUNOUCHI, CHIYODA-KU, TOKYO 100-8310, JAPAN