

MITSUBISHI ELECTRIC

Air Conditioning For Building Application

Filter Box PAC-KE91·92·93·94·95TB-E

Installation Manual

This installation manual contains only the description of how to install the Filter box PAC-KE91·92·93·94·95TB-E. For information about how to wire and how to install air conditioning units, see the installation manual for them.
For your safety, first be sure to read "1 Safety Precautions" described below thoroughly and then install the Filter box PAC-KE91·92·93·94·95TB-E correctly.

1 Safety Precautions

- The following two symbols are used to denote dangers that may be caused by incorrect use and their degree:

⚠ WARNING	This symbol denotes what could lead to serious injury or death if you misuse the PAC-KE91·92·93·94·95TB-E.
⚠ CAUTION	This symbol denotes what could lead to a personal injury or damage to your property if you misuse the PAC-KE91·92·93·94·95TB-E.

- After reading this installation manual, keep it in a place where the final user can see it anytime he or she wants to it.
When someone moves, repairs or uses the PAC-KE91·92·93·94·95TB-E, make sure that this manual is forwarded to the final user.

⚠ WARNING

Always have the unit installed by Authorized Mitsubishi Representative or similar professional.
Improper installation by the user could result in problems such as water leakage, electric shock or fire.

Install the unit according to this Installation Manual.
If the unit is installed improperly, water leakage, electric shock or fire may result.

Always use the designated cables and connect them properly. When connecting the terminals, make sure that external forces from the cable is not being conveyed to the terminal and then tighten it securely.
Improper or loose connections could cause excessive heat or fire.

Have all electric work performed by a properly licensed electrician. Electric work should be performed in strict adherence to procedures to this Installation Manual. Always provide a dedicated power supply.
If the capacity of the power supply is inadequate, it could result in problems such as electric shock or fire.

Only use Mitsubishi-approved accessories, such as an air cleaner, humidifier or electric heater.
Always have such accessories installed by an Authorized Mitsubishi Representative or similar professional. Improper installation by the user may result in water leakage, electric shock or fire.

Never modify the unit and always have repairs performed by an Authorized Mitsubishi Representative.
Improper repair could result in problems such as water leakage, electric shock or fire.

⚠ CAUTION

PRECAUTIONS BEFORE INSTALLATION

Never use for special applications such as storing food, plants, precision equipment or art.
The quality of these items may deteriorate.

Always provide adequate signal noise protection when installing in facilities such as hospitals and communication stations.
Equipment at these facilities, such as inverters, in-house generators, high-frequency medical equipment, two-way communication equipment, may cause the air conditioner to operate improperly. Conversely, the signal noise from the air conditioner may affect the operation of medical equipment and two-way communication equipment and this could interfere with the medical treatment being given a patient or cause disturbances or interference in video broadcasting equipment.

Never use the unit in special environments.
Special environments with high concentrations of oil, steam or sulfuric gases will reduce the performance of the air condition and cause its parts to deteriorate.

Never install the unit where run-off could result in damage.
If the humidity in the room exceeds 80% or if the drain becomes clogged, water may drain off of the indoor unit. When the unit is used for heating, there may be drainage from the outdoor unit. If required, provide collector drain for the outdoor unit.

PRECAUTIONS BEFORE REMOVE AND ELECTRIC WORK

Route wiring so that there is no tension.
Tension could cause the wire to break and this could result in excessive heat or fire.

Use care when transporting the unit.
•Always use two or more people for lifting a product weight 20 kg. or more.
•Some products are packaged with plastic wrapping bands. Never use these for lifting or transporting the product.
•Never touch the fins on the heat exchanger. They are sharp and could cause cuts.
•Never allow children to play with the plastic bags used for packaging. Always tear them up when disposing. A child could suffocate in these bags.

Dispose of packing materials properly.

PRECAUTIONS BEFORE TEST RUN

Never touch the switch with wet hands.
Electric shock could occur.

Never operate the air conditioner with the air filter removed.
Particles will enter into the air conditioner and cause damage.

Never operate the air conditioner with the panel or guard removed.
The hand could come in contact with rotating, hot or high-pressure components. They could cause electrical shock or entanglement.

Never turn off the power supply immediately after stopping the unit.
Wait five minutes or more before turning off the power supply. Turning off the power supply before that time could result in water leakage or damage.

2 Confirming the Supplied Parts

1. Model names and applicable models

Model name	Applicable types	Applicable filter	
		Size	Q'ty
PAC-KE91TB-E	PEFY-P20·25·32VMA(L)-E	700×240	1
PAC-KE92TB-E	PEFY-P40·50VMA(L)-E PEAD-RP35·50JA(L)	900×240	1
PAC-KE93TB-E	PEFY-P63·71·80VMA(L)-E PEAD-RP60·71JA(L)	550×240	2
PAC-KE94TB-E	PEFY-P100·125VMA(L)-E PEAD-RP100·125JA(L)	700×240	2
PAC-KE95TB-E	PEFY-P140VMA(L)-E PEAD-RP140JA(L)	700×240	1
		+ 900×240	1

2. Provided parts

Check that the packet includes the following parts in addition to this installation manual.

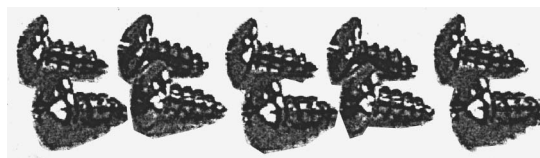
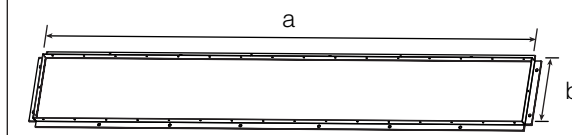
PARTS	SHAPE	Q'ty	Model name	
① SCREW(4×10)		20	PAC-KE91TB-E	
		24	PAC-KE92·93TB-E	
		30	PAC-KE94·95TB-E	
② SUCTION FLANGE		a × b	-	
		657×208	1	PAC-KE91TB-E
		857×208	1	PAC-KE92TB-E
		1057×208	1	PAC-KE93TB-E
		1357×208	1	PAC-KE94TB-E
		1557×208	1	PAC-KE95TB-E

3 Attach the filter box

Attach the filter box before installing the indoor unit.

- Remove the filter on the indoor unit. (Fig. 3-1)

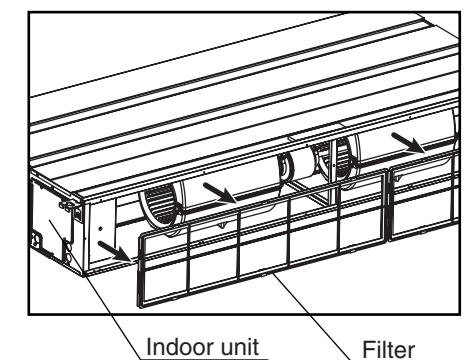
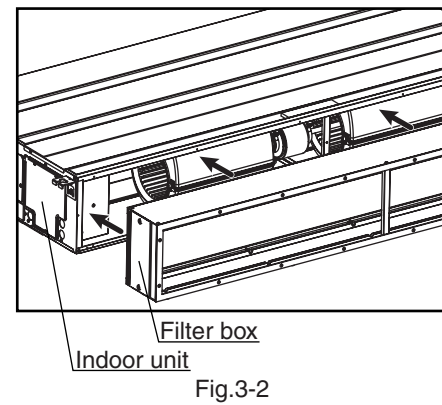

Fig.3-1

2. Install the filter box on the indoor unit with the supplied screws.
(Fig. 3-2)

PAC-KE91·92·93TB-E 10 pcs.
PAC-KE94·95TB-E 12 pcs.

Note) Failure to firmly tightened the screws will cause air leakage. Make sure the screws are firmly tightened.



3. Install the supplied suction flange on the filter box with the supplied screws. (Fig. 3-3)

PAC-KE91TB-E 8 pcs.
PAC-KE92·93TB-E 12 pcs.
PAC-KE94·95TB-E 16 pcs.

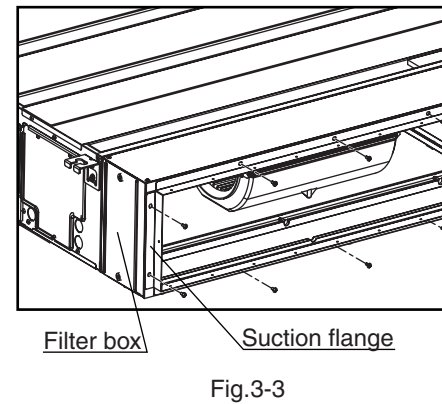

4 Installing the filter

1. Installation that allows for maintenance from the side

(1) Remove the side panel from the filter box. (Fig. 4-1-1)

(2) Insert the filter that was removed in step 3-1 above along the top and bottom rails. (Fig. 4-1-2)
When using the PAC-KE93, 94, or 95TB model, join the two filters before inserting them. (Fig. 4-1-3)

If the two filters are inserted without them being joined together, it will render the one in the back difficult to remove.

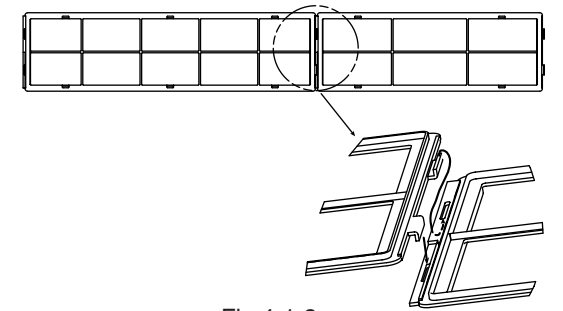
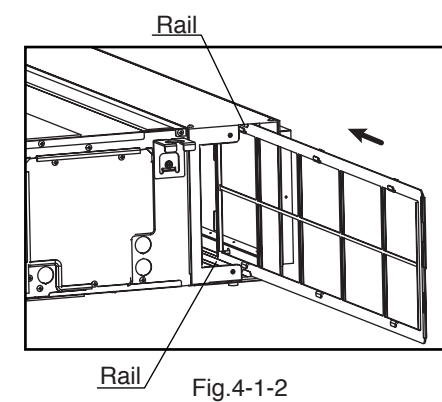
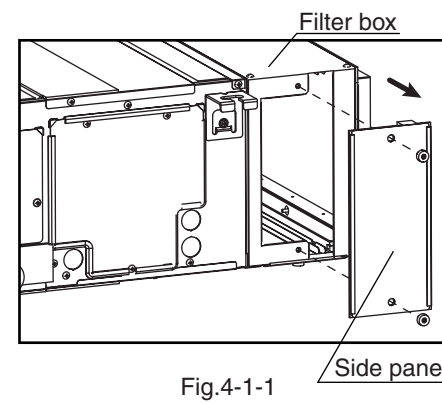

Fig.4-1-3

⚠ CAUTION

Never place your hand inside the filter box during maintenance. If the filter tabs become caught when the filter is removed for maintenance, use a long stick or similar item to remove the remaining filter.

2. Installation that allows for maintenance from the bottom

(1) Remove the under panel from the filter box. (Fig. 4-2-1)

(2) Insert the filter that was removed in step 3-1 above through the bottom of the filter box. (Fig. 4-2-2)

(3) Insert the filter between the insulators on the top plate of the filter box until the filter is completely inside the filter box, and place the filter on the under frame of the filter box. (Fig. 4-2-3)

(4) Install the under panel.

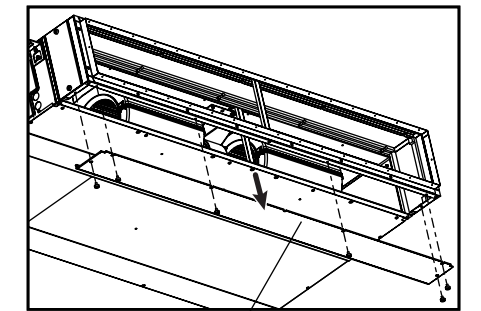

Fig.4-2-1

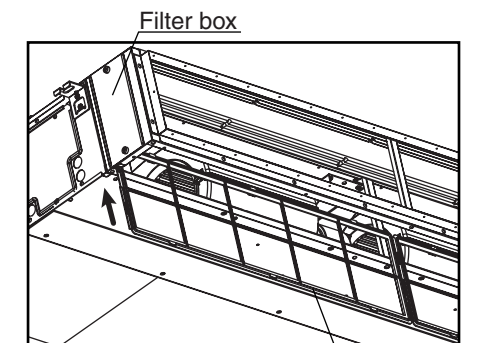

Fig.4-2-2

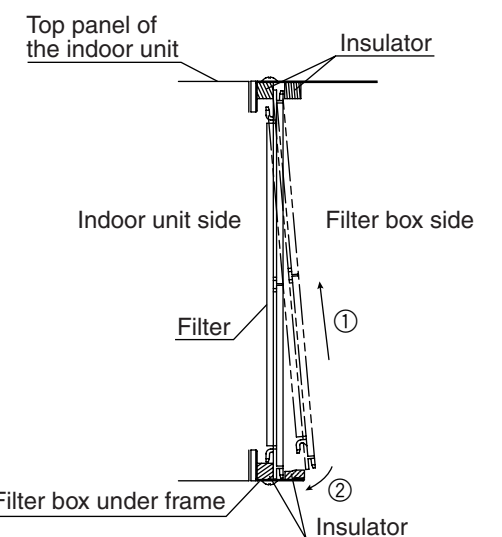

Fig.4-2-3

Final Check

The last step of the procedure is to make sure that nothing has been overlooked during the procedure. In addition, once the filter box has been mounted and the above procedure has been completed, carefully check for air leakage at the connections of the indoor unit.

For more detailed information, please consult your dealer.