

Interface (Cased)

PAC-IF013B-E PAC-SIF013B-E

INSTALLATION MANUAL

For safe and correct use, read this manual thoroughly before installing the interface unit.

FOR INSTALLER**OPERATION MANUAL**

For safe and correct use, please read this operation manual thoroughly before operating the interface unit.

FOR USER**English (EN)****INSTALLATIONSHANDBUCH**

Aus Sicherheitsgründen und zur richtigen Verwendung vor der Installation der Schnittstelleneinheit das vorliegende Handbuch gründlich durchlesen.

FÜR INSTALLATEURE**BEDIENUNGSHANDBUCH**

Aus Sicherheitsgründen und zur richtigen Verwendung vor dem Betrieb der Schnittstelleneinheit das vorliegende Bedienungshandbuch gründlich durchlesen.

FÜR BENUTZER**Deutsch (DE)****MANUEL D'INSTALLATION**

Avant d'installer l'unité d'interface, lire attentivement ce manuel pour une utilisation sûre et correcte.

POUR L'INSTALLATEUR**MANUEL D'UTILISATION**

Avant d'installer l'unité d'interface, lire attentivement ce guide d'utilisation pour une utilisation sûre et correcte.

POUR L'UTILISATEUR**Français (FR)****INSTALLATIEHANDLEIDING**

Lees deze handleiding voor een veilig en juist gebruik goed door voordat u met het installeren van het interface-apparaat begint.

VOOR DE INSTALLATEUR**BEDIENINGSHANDLEIDING**

Lees deze bedieningshandleiding voor een veilig en juist gebruik goed door voordat u het interface-apparaat bedient.

VOOR DE GEBRUIKER**Nederlands (NL)****MANUAL DE INSTALACIÓN**

Para un uso correcto y seguro, lea detalladamente este manual antes de instalar la unidad de interfaz.

PARA EL INSTALADOR**MANUAL DE INSTRUCCIONES**

Para un uso correcto y seguro, lea detalladamente este manual de instrucciones antes de instalar la unidad de interfaz.

PARA EL USUARIO**Español (ES)****MANUALE DI INSTALLAZIONE**

Per un uso sicuro e corretto, leggere attentamente il presente manuale prima di installare l'unità interfaccia.

PER L'INSTALLATORE**ISTRUZIONI DI FUNZIONAMENTO**

Per un uso sicuro e corretto, leggere attentamente le istruzioni di funzionamento prima di utilizzare l'unità interfaccia.

PER L'UTENTE**Italiano (IT)****ΕΓΧΕΙΡΙΔΙΟ ΟΔΗΓΙΩΝ ΕΓΚΑΤΑΣΤΑΣΗΣ**

Για την ασφαλή και σωστή χρήση, διαβάστε προσεκτικά αυτό το εγχειρίδιο προτού εγκαταστήσετε τη μονάδα διασύνδεσης.

ΓΙΑ ΑΥΤΟΝ ΠΟΥ ΚΑΝΕΙ ΤΗΝ ΕΓΚΑΤΑΣΤΑΣΗ**ΕΓΧΕΙΡΙΔΙΟ ΟΔΗΓΙΩΝ ΧΡΗΣΕΩΣ**

Για την ασφαλή και σωστή χρήση, διαβάστε προσεκτικά αυτό το εγχειρίδιο λειτουργίας πριν από τον χειρισμό της μονάδας διασύνδεσης.

ΓΙΑ ΤΟΝ ΧΡΗΣΤΗ**Ελληνικά (GR)****MANUAL DE INSTALAÇÃO**

Para uma utilização segura e correcta, leia atentamente este manual antes de instalar a unidade de interface.

PARA O INSTALADOR**MANUAL DE OPERAÇÃO**

Para uma utilização segura e correcta, leia atentamente este manual de operação antes de instalar a unidade de interface.

PARA O UTILIZADOR**Português (PT)****INSTALLATIONSMANUAL**

For sikker og korrekt brug skal denne manual læses grundigt igennem, inden interfaceenheden installeres.

TIL INSTALLATØREN**BRUGSVEJLEDNING**

For sikker og korrekt brug skal denne brugsanvisning læses grundigt igennem, inden interfaceenheden betjenes.

TIL BRUGER**Dansk (DA)****INSTALLATIONSMANUAL**

Läs igenom denna manual noggrant innan du installerar gränssnittsenheten för en säker och korrekt användning.

FÖR INSTALLATÖREN**ANVÄNDARMANUAL**

För en säker och korrekt användning, vänligen läs igenom denna driftmanual noggrant innan du använder gränssnittsenheten.

FÖR ANVÄNDAREN**Svenska (SV)****MONTAJ ELKİTABI**

Güvenli ve doğru kullanım için arayüz ünitesini monte etmeye başlamadan önce bu kılavuzu dikkatlice okuyun.

MONTÖR İÇİN**İşletme Elkitabı**

Güvenli ve doğru kullanım için arayüz ünitesini kullanmaya başlamadan önce lütfen bu kılavuzu dikkatlice okuyun.

KULLANICI İÇİN**Türkçe (TR)****РУКОВОДСТВО ПО УСТАНОВКЕ**

Чтобы обеспечить безопасную и правильную эксплуатацию устройства, перед установкой интерфейсного блока внимательно прочтите данное руководство.

ДЛЯ УСТАНОВИТЕЛЯ**РУКОВОДСТВО ПО ЭКСПЛУАТАЦИИ**

Чтобы обеспечить безопасную и правильную эксплуатацию устройства, перед эксплуатацией интерфейсного блока внимательно прочтите данное руководство по эксплуатации.

ДЛЯ ПОЛЬЗОВАТЕЛЯ**Русский (RU)**

Contents

1. Safety precautions.....	2	5. Remote controller operation	15
2. Installing the interface unit.....	3	6. Service and Maintenance.....	20
3. System	4	7. Requirement on local design.....	21
4. Electrical work	7		

1. Safety precautions

- ▶ Before installing the interface unit, make sure you read all the “Safety precautions”.
- ▶ Please report to your supply authority or obtain their consent before connecting this equipment to the power supply system.

⚠ Warning:
Precautions that must be observed to prevent injuries or death.

⚠ Caution:
Precautions that must be observed to prevent damages to the unit.

- ⚠ Warning:**
- The unit must not be installed by the user. Ask an installer or an authorised technician to install the unit. If the unit is installed improperly, electric shock, or fire may be caused.
 - For installation work, follow the instructions in the Installation Manual and use tools and pipe components specifically made for use with refrigerant specified in the outdoor unit installation manual.
 - The unit must be installed according to the instructions in order to minimize the risk of damages by earthquakes, typhoons, or strong winds. Improperly installed unit may fall down and cause damage or injury.
 - The unit must be securely installed on a structure that can sustain its weight. If the unit is mounted on an unstable structure, it may fall down and cause damage or injury.
 - All electric work must be performed by a qualified technician according to local regulations and the instructions given in this manual. The unit must be powered by dedicated power lines and the correct voltage and circuit breakers must be used. Power lines with insufficient capacity or incorrect electrical work may result in electric shock or fire.

After installation, perform the test run to ensure normal operation. Then explain your customer the “Safety Precautions,” use, and maintenance of the unit based on the information in the Operation Manual provided by local application manufacturer. Both the Installation Manual and the Operation Manual must be given to the user. These manuals must always be kept by the actual users.

⚡ :Indicates a part which must be grounded.

⚠ Warning:
Carefully read the labels attached to the unit.

- Only the specified cables can be used for wiring. Connections must be made securely without tension on the terminals. If cables are connected or installed improperly, it may result in overheating or fire.
- Terminal block cover panel of the unit must be firmly fixed. If the cover panel is mounted improperly, dust and moisture may enter the unit, and it may cause electric shock or fire.
- Make sure to use accessories authorised by Mitsubishi Electric and ask an installer or an authorised technician to install them. If accessories are improperly installed, it may cause electric shock, or fire.
- Do not remodel the unit. Consult an installer for repairs. If alterations or repairs are not performed correctly, it may cause electric shock or fire.
- The user should never attempt to repair the unit or transfer it to another location. If the unit is installed improperly, it may cause electric shock or fire. If the interface unit needs to be repaired or moved, ask an installer or an authorised technician.
- When installing sensors and parts, do not expose the terminals.

1.1. Before installation (Environment)

- ⚠ Caution:**
- Do not install the interface unit in outdoor location as it is designed for indoor installation only. Otherwise electric shock or breakdown may be caused by water drop, wind or dust.
 - Do not use the unit in an unusual environment. If the interface unit is installed or exposed to steam, volatile oil (including machine oil), or sulfuric gas, or exposed to briny air, the internal parts can be damaged.
 - Do not install the unit where combustible gases may leak, be produced, flow, or accumulate. If combustible gas accumulates around the unit, it may cause fire or explosion.

- When installing the unit in a hospital or in a building where communications equipment are installed, you may need to take measure to noise and electronic interference. Inverters, home appliances, high-frequency medical equipment, and radio communications equipment can cause the interface unit to malfunction or to breakdown. At the same time, the noise and electric interference from the interface unit may disturb the proper operation of medical equipment, and communications equipment.

1.2. Before installation or relocation

- ⚠ Caution:**
- Be very careful when moving the units. Do not hold the packaging bands. Wear protective gloves to unpack and to move it, in order to avoid your hands being injured by parts.

- Be sure to safely dispose of the packaging materials. Packaging materials, such as nails and other metal or wooden parts may cause injury.
- Do not wash the interface unit. You may receive an electric shock.

1.3. Before electric work

- ⚠ Caution:**
- Be sure to install a circuit breaker. If it is not installed, there may be a risk of electric shock.
 - For the power lines, use standard cables of sufficient capacity. Otherwise, it may cause a short circuit, overheating, or fire.
 - When installing the power lines, do not apply tension to the cables. The cables may be cut or overheated resulting in a fire.

- Make sure to ground the unit. Do not connect the ground wire to gas or water pipes, lightning rods, or telephone grounding lines. If the unit is not properly grounded, there may be a risk of electric shock.
- Make sure to use circuit breakers (ground fault interrupter, isolating switch (+B fuse), and molded case circuit breaker) with the specified capacity. If the circuit breaker capacity is larger than the specified capacity, breakdown or fire may result.

1.4. Before starting the test run

- ⚠ Caution:**
- Turn on the main power switch of the outdoor unit more than 12 hours before starting operation. Starting operation immediately after turning on the power switch can severely damage the internal parts. Keep the main power switch turned on during the operation period.

- Before starting operation, check that all protective parts are correctly installed. Make sure not to get injured by touching high voltage parts.
- Do not touch any switch with wet hands. There may be a risk of electric shock.
- After stopping operation, wait at least 5 minutes before turning off the main power. Otherwise, it may cause breakdown.

2. Installing the interface unit

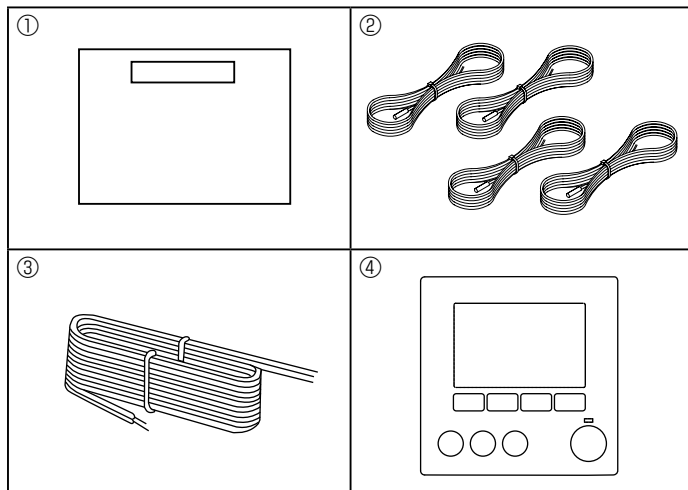

<Fig. 2.1.1>

2.1. Check the parts (Fig. 2.1.1)

The interface unit should be supplied with the following parts.

	Part Name	PAC-IF013B-E	PAC-SIF013B-E
①	Interface unit	1	1
②	Thermistor	4	4
③	Remote controller cable (5m)	1	—
④	Remote controller	1	—

2.2. Choosing the interface unit installation location

- Do not install the interface unit in outdoor location as it is designed for indoor installation only. (The interface board and casing are not waterproof.)
- Avoid locations where the unit is exposed to direct sunlight or other sources of heat.
- Select a location where easy wiring access to the power source is available.
- Avoid locations where combustible gases may leak, be produced, flow, or accumulate.
- Select a level location that can bear the weight and vibration of the unit.
- Avoid locations where the unit is exposed to oil, steam, or sulfuric gas.
- Do not install in location that is hot or humid for long period of time.

2.3. Installing the interface unit (Fig. 2.3.1, 2.3.2, 2.3.3)

1. Remove 2 screws (A) from interface unit and remove the cover by sliding it upward (See Fig. 2.3.1).
2. Install the 4 screws (locally supplied) in 4 holes (C) hole.
* To prevent the unit from falling off the wall, select the appropriate screws (locally supplied) and secure the base horizontally to the appropriate wall location. (See Fig. 2.3.2)

Ⓐ Screw Ⓑ Cover Ⓒ Hole for installation

	PAC-IF013B-E	PAC-SIF013B-E
Weight	2.5 kg + ACCESSORIES 0.8 kg	2.5 kg + ACCESSORIES 0.4 kg
Allowable ambient temperature	0 to 35°C	0 to 35°C
Allowable ambient humidity	80% RH or less	80% RH or less

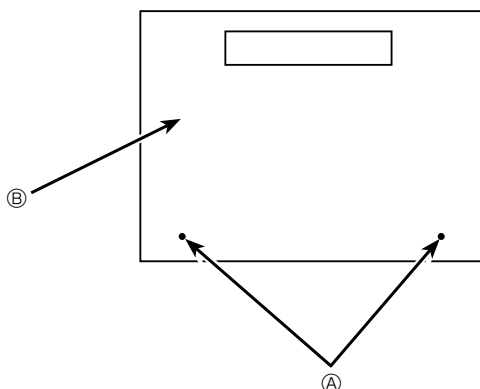

<Fig. 2.3.1>

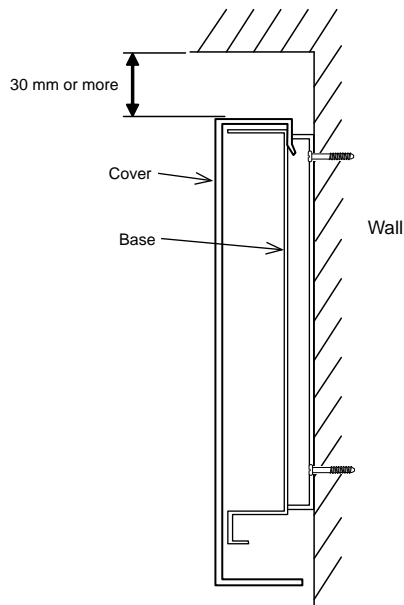

<Fig. 2.3.2>
Service space

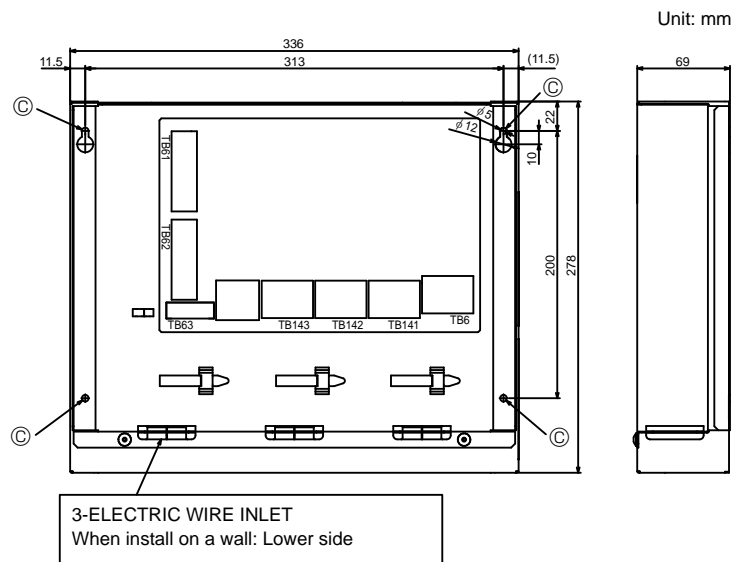

<Fig. 2.3.3>

3. System

Step mode (Input)	Target temperature	Number of outdoor unit	Intelligent multiple outdoor unit control	System
Manual	-	1	Not available	See (1-1) below.
		2-6	Apply	See (2-1) below.
			Not apply	See (1-1) below.*1
Auto	Supply air temp. control	1-5	Not available	See (1-2) below.
	Return air temp. control	1-5	Not available	See (1-3) below.

*1. It is recommended to select Intelligent multiple outdoor unit control.
 Design local AHU controller to make sure the following points.

- Minimum capacity request should be 20% or more of total capacity.
- Operate all outdoor units when outdoor temperature is below -15 °C.

3.1. System configuration (Single outdoor unit)

(1-1) Manual step mode *1

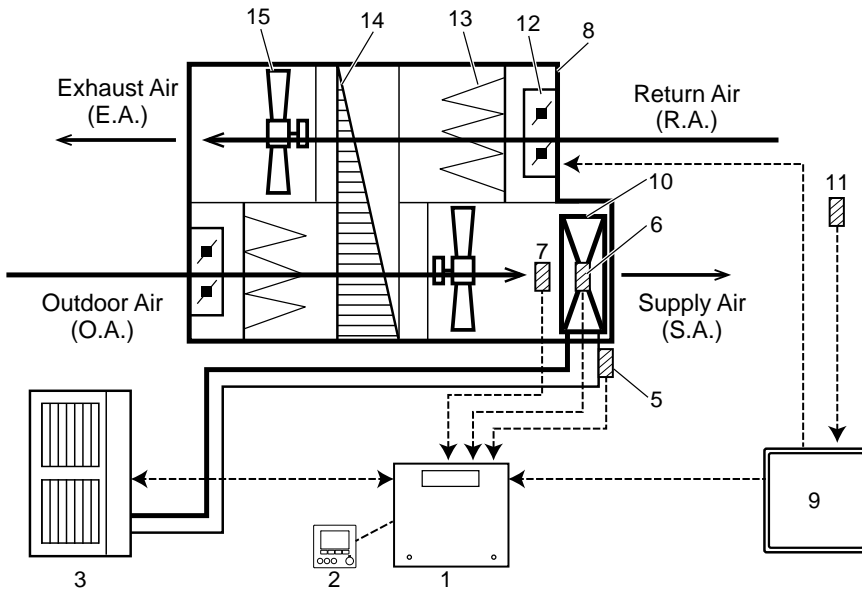

<Fig. 3.1.1>

*1. Manual step mode:

- Variable capacity request signals for heat pump need to be calculated by AHU local controller.
- AHU local controller can send "Capacity steps" by non-voltage contact signals or analog signals to the interface unit.
- Operation mode can be set by remote controller, external input or DIP switch.

Note

- Do NOT select STEP 0 for 3 minutes after compressor is ON. (Keep compressor ON for 3 minutes at least.)
- When changing STEP, make it less than 5 steps in a single request, and keep at least 5 minutes interval between the changes.
- Keep operation range shown at the following section 3.3.
- Do NOT send STEP 0 during defrost operation.
- Do NOT change operation mode frequently.

No.	Part name	System (1-1)
1	Interface unit	✓
2	Remote controller	✓
3	Outdoor unit	✓
4	Target air temp. thermistor (TH1)	- *2
5	Ref. liquid temp. thermistor (TH2)	✓
6	2-Phase temp. thermistor (TH5)	✓ *3
7	HEX inlet (Coil on) temp. thermistor (TH11)	✓
8	Air-Handling Unit (AHU) (Local supply)	✓
9	AHU local controller (Local supply)	✓
10	Heat exchanger of AHU (Local supply)	✓
11	Target air temp. thermistor (Local supply)	✓
12	Louver (Local supply)	✓
13	Air filter (Local supply)	✓
14	Heat recovery (Local supply)	✓
15	Fan (Local supply)	✓

*2. Set the DIP SW 2-8 to ON.
 *3. If outdoor unit is SHW series, It's not needed to install this thermistor, and set the DIP SW 1-5 to ON.

3. System

(1-2) Auto step mode *4 & Supply air temp. control

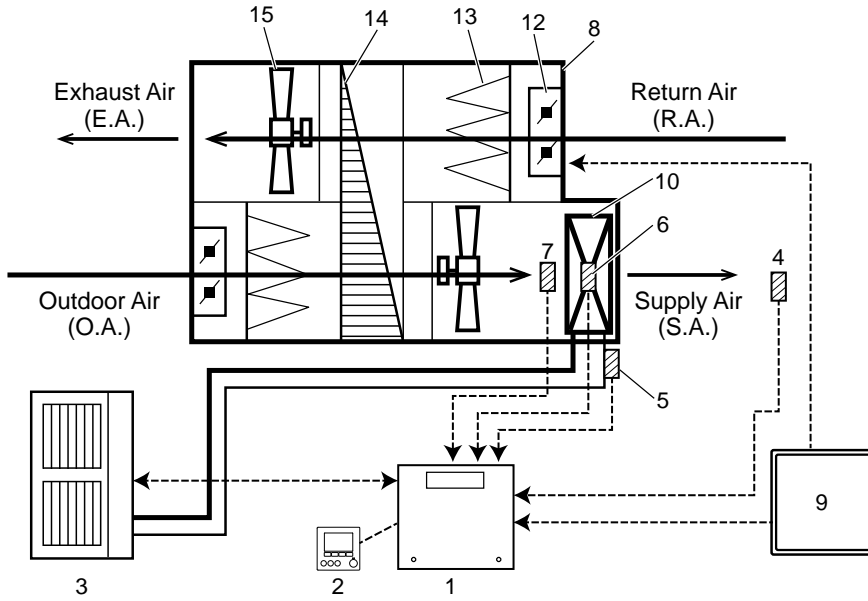

<Fig. 3.1.2>

*4. Auto step mode:

- In this mode, the capacity step of the outdoor unit is controlled automatically to let the target temperature reach the set temperature.

Note

- Auto change over function between cooling and heating mode is NOT available in this system.
- Keep operation range shown at the following section 3.3.
- Standard setting of DIP SW3-4 and SW3-5 is 3°C (SW3-4 : ON , SW3-5 : OFF). (Refer to "4.1.7 Switch setting".)

No.	Part name	System (1-2)
1	Interface unit	✓
2	Remote controller	✓
3	Outdoor unit	✓
4	Target air temp. thermistor (TH1)	✓
5	Ref. liquid temp. thermistor (TH2)	✓
6	2-Phase temp. thermistor (TH5)	✓*5
7	HEX inlet (Coil on) temp. thermistor (TH11)	✓
8	Air-Handling Unit (AHU) (Local supply)	✓
9	AHU local controller (Local supply)	✓
10	Heat exchanger of AHU (Local supply)	✓
11	Target air temp. thermistor (Local supply)	—
12	Louver (Local supply)	✓
13	Air filter (Local supply)	✓
14	Heat recovery (Local supply)	✓
15	Fan (Local supply)	✓

*5. If outdoor unit is SHW series, It's not needed to install this thermistor, and set the DIP SW 1-5 to ON.

(1-3) Auto step mode *6 & Return/ Room air temp. control *7

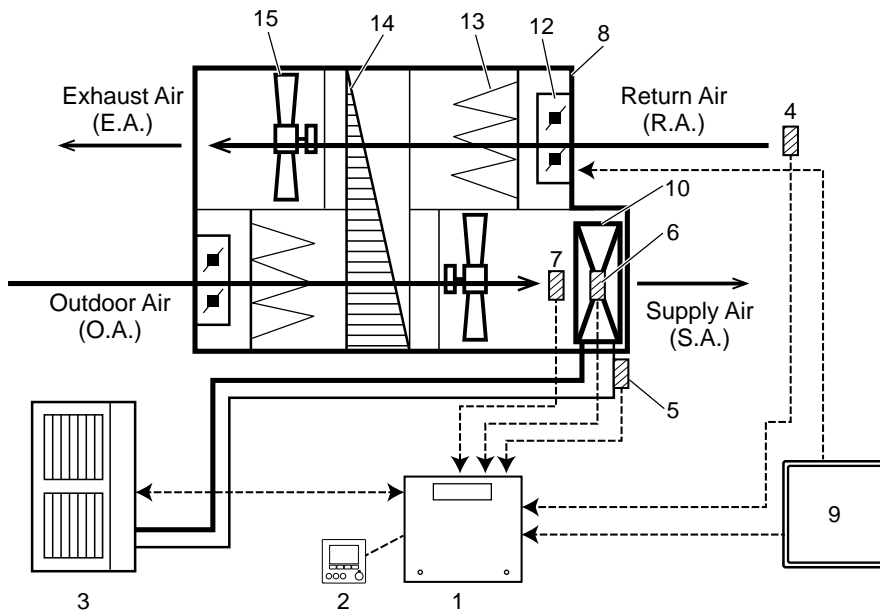

<Fig. 3.1.3>

*6. Auto step mode:

- In this mode, the capacity step of the outdoor unit is controlled automatically to let the target temperature reach the set temperature.

*7. Return/Room air temp. control:

- Set the DIP SW 1-7 to ON.

Note

- Auto change over function between cooling and heating mode is available ONLY when this system is selected and the input selection of capacity setting (DIP SW1 and SW6) is "No input (Auto step mode)".
- Keep operation range shown at the following section 3.3.

No.	Part name	System (1-3)
1	Interface unit	✓
2	Remote controller	✓
3	Outdoor unit	✓
4	Target air temp. thermistor (TH1)	✓
5	Ref. liquid temp. thermistor (TH2)	✓
6	2-Phase temp. thermistor (TH5)	✓*8
7	HEX inlet (Coil on) temp. thermistor (TH11)	✓
8	Air-Handling Unit (AHU) (Local supply)	✓
9	AHU local controller (Local supply)	✓
10	Heat exchanger of AHU (Local supply)	✓
11	Target air temp. thermistor (Local supply)	—
12	Louver (Local supply)	✓
13	Air filter (Local supply)	✓
14	Heat recovery (Local supply)	✓
15	Fan (Local supply)	✓

*8. If outdoor unit is SHW series, It's not needed to install this thermistor, and set the DIP SW 1-5 to ON.

3. System

3.2. System configuration (Intelligent multiple outdoor unit control *1)

(2-1) Manual step mode (example)

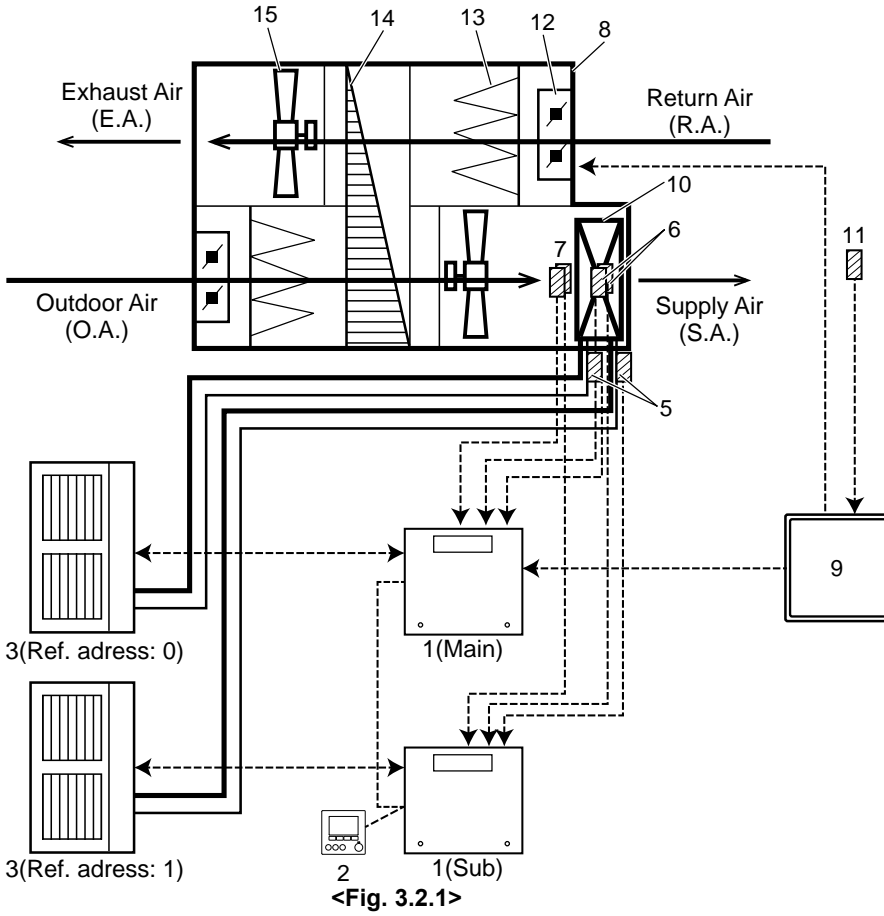

*1. Interface system receives step request signal correspond to total capacity of outdoor units, and calculates necessary capacity for each outdoor unit automatically.

Note

- This intelligent multiple outdoor unit control function is available only when Manual step mode is selected.
- Up to 6 outdoor units can be connected.
- 2 different type of outdoor units (capacity and/or series) can be mixed, but connecting the same capacity outdoor units is highly recommended.
- Ref. address setting on each outdoor unit is needed.
- Interface unit which connects to the Ref. address 0 outdoor unit, becomes main interface unit.
- Connect AHU local controller (Part No. 9) to the main interface unit.
- Connect ONE remote controller (Part No. 2) to the interface unit.
- Connect between the interface units with a remote controller (daisy chain). MAX. : 500m
- When using this function, set the DIP SW 1-8 of all interface unit to ON.
- Do NOT select STEP 0 for 3 minutes after compressor is ON. (Keep compressor ON for 3 minutes at least.)
- When changing STEP, make it less than 5 steps in a single operation, and keep at least 5 minutes interval between the changes.
- Keep operation range shown at the following section 3.3.
- Do NOT send STEP 0 during defrost operation.
- Do NOT change operation mode frequently.

No.	Part name	System (2-1)
1	Interface unit	✓
2	Remote controller	✓
3	Outdoor unit	✓
4	Target air temp. thermistor (TH1)	— ^{*2}
5	Ref. liquid temp. thermistor (TH2)	✓
6	2-Phase temp. thermistor (TH5)	✓ ^{*3}
7	HEX inlet (Coil on) temp. thermistor (TH11)	✓
8	Air-Handling Unit (AHU) (Local supply)	✓
9	AHU local controller (Local supply)	✓
10	Heat exchanger of AHU (Local supply)	✓
11	Target air temp. thermistor (Local supply)	✓
12	Louver (Local supply)	✓
13	Air filter (Local supply)	✓
14	Heat recovery (Local supply)	✓
15	Fan (Local supply)	✓

*2. Set the DIP SW 2-8 to ON.

*3. If outdoor unit is SHW series, It's not needed to install this thermistor, and set the DIP SW 1-5 to ON.

3.3. Indoor operation range

Mode	Number of outdoor unit	HEX inlet air temp. operation range
Cooling	1 or more	15 - 32 °C
Heating	1	0 - 28 °C
	2 or more	5 - 28 °C

4. Electrical work

4.1. Electrical connection

All electrical work should be carried out by a suitably qualified technician. Failure to comply with this could lead to electrocution, fire, and death. All wiring should be according to national wiring regulations.

Connections should be made to the terminals indicated in the following figures.

Use ring terminals and insulate the wires.

Tighten the screw from the bottom terminals first.

Notes:

1. Do not run the low voltage cables through a slot that the high voltage cables go through.
2. Do not bundle power cables together with other cables.
3. Bundle cables as Fig. 4.1.1 by using clamps.

4.1.1. Interface unit power supplied from outdoor unit

The following connection patterns are available.

The outdoor unit power supply patterns vary on models.

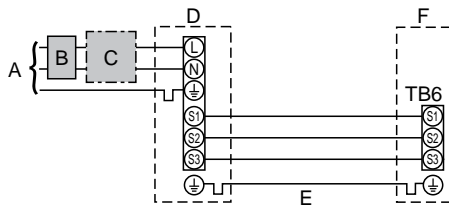

- A Outdoor unit power supply
- B Earth leakage breaker *1, *2
- C Wiring circuit breaker or isolating switch
- D Outdoor unit
- E Interface unit/outdoor unit connecting cables
- F Interface unit

*1 If the installed earth leakage circuit breaker does not have a function to protect over-current, install a breaker with that function along the same power line.

*2. A breaker with at least 3.0 mm contact separation in each pole shall be provided. Use earth leakage breaker (NV).

The breaker shall be provided to ensure disconnection of all active phase conductors of the supply.

Note:

In accordance with IEE regulations the circuit breaker/isolating switch located on the outdoor unit should be installed with lockable devices (health and safety).

Wiring Wire No. x size (mm ²)	Interface unit - Outdoor unit	*3	3 x 1.5 (polar)
	Interface unit - Outdoor unit earth	*3	1 x Min. 1.5
Circuit rating	Interface unit - Outdoor unit S1-S2	*4	230 V AC
	Interface unit - Outdoor unit S2-S3	*4	24 V DC

*3. Max. 45 m

If 2.5 mm² used, Max. 50 m

If 2.5 mm² used and S3 separated, Max. 80 m

*4. The values given in the left table are not always measured against the ground value.

Notes: 1. Wiring size must comply with the applicable local and national code.

2. Interface unit/outdoor unit connecting cords shall not be lighter than polychloroprene sheathed flexible cord. (Design 60245 IEC 57)
Interface unit power supply cords shall not be lighter than polychloroprene sheathed flexible cord. (Design 60227 IEC 53)
3. Install an earth longer than other cables.

4.1.2. Separate interface unit/outdoor unit power supplies

The following connection patterns are available.

The outdoor unit power supply patterns vary on models.

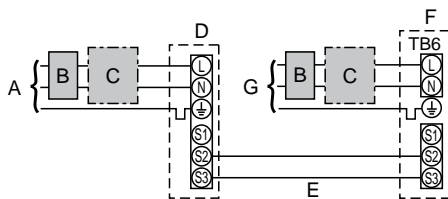

- A Outdoor unit power supply
- B Earth leakage breaker *1, *2
- C Wiring circuit breaker or isolating switch
- D Outdoor unit
- E Interface unit/outdoor unit connecting cables
- F Interface unit
- G Interface unit power supply

*1 If the installed earth leakage circuit breaker does not have a function to protect over-current, install a breaker with that function along the same power line.

Note:

In accordance with IEE regulations the circuit breaker/isolating switch located on the outdoor unit should be installed with lockable devices (health and safety).

If the interface and outdoor units have separate power supplies, refer to the table below.

	Separate power supply specifications			
Interface unit controller connector (CNS2) connection change	Disconnected			
Outdoor unit DIP switch settings (when using separate interface unit/outdoor unit power supplies only)	ON			3
	OFF	1	2	(SW8)
Set the SW8-3 to ON.				

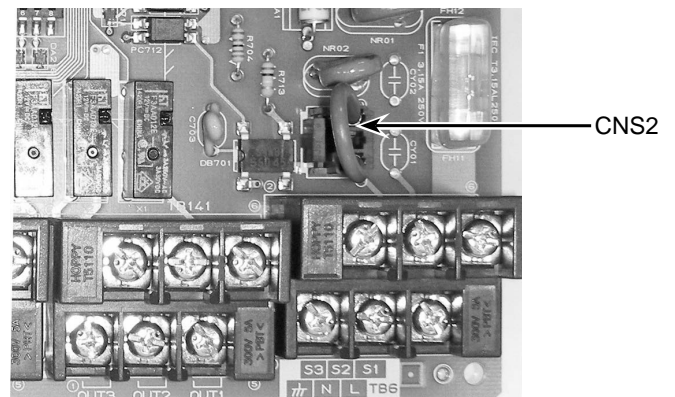

<Photo 4.1.2>

4. Electrical work

Interface unit power supply		~N 230 V 50 Hz
Interface unit input capacity		*2
Main switch (Breaker)		16 A
Wiring Wire No. x size (mm ²)	Interface unit power supply	2 x Min. 1.5
	Interface unit power supply earth	1 x Min. 1.5
	Interface unit-Outdoor unit	*3
	Interface unit-Outdoor unit earth	—
Circuit rating	Interface unit L-N	*4
	Interface unit-Outdoor unit S1-S2	*4
	Interface unit-Outdoor unit S2-S3	*4
		230 V AC
		—
		24 V DC

*2. A breaker with at least 3.0 mm contact separation in each pole shall be provided. Use earth leakage breaker (NV). The breaker shall be provided to ensure disconnection of all active phase conductors of the supply.

*3. Max. 120 m

*4. The values given in the left table are not always measured against the ground value.

Notes: 1. Wiring size must comply with the applicable local and national code.

2. Interface unit/outdoor unit connecting cords shall not be lighter than polychloroprene sheathed flexible cord. (Design 60245 IEC 57)

Interface unit power supply cords shall not be lighter than polychloroprene sheathed flexible cord. (Design 60227 IEC 53)

3. Install an earth longer than other cables.

4.1.3. Connecting thermistor cable

Connect the thermistor ② for the interface controller.

1. Target temp. thermistor (TH1)

Connect the thermistor for the target temp. to 1 and 2 on the terminal block (TB61) on the interface controller.

2. HEX inlet temp. thermistor (TH11)

Connect the thermistor for the HEX inlet temp. to 3 and 4 on the terminal block (TB61) on the interface controller.

3. Ref. liquid temp. thermistor (TH2)

Connect the thermistor for the ref. liquid temp. to 5 and 6 on the terminal block (TB61) on the interface controller.

4. 2-phase temp. thermistor (TH5)

Connect the thermistor for the 2-phase temp. to 7 and 8 on the terminal block (TB61) on the interface controller.

When the thermistor cables are too long, cut it to the appropriate length.

Do not bind it in the interface unit.

The 4 thermistors have the same specification except the color of cables, thus we do not specify which thermistor should be installed to which position.

Notes: When multiple outdoor units are connected, connect thermistors to each interface unit respectively.

⚠ **Caution:**

Do not route the thermistor cables together with power cables.

The sensor part of the thermistor should be installed where user can not access. (It should be separated by the supplementary insulation from areas the user can access.)

4.1.4. Connecting external input

Demand control is available by external input.

Select input type by setting the switch of the interface controller, and it is possible to set capacity request when manual step mode ("Analog input", "Remote switch" or "Modbus") is selected.

Switch1, Switch 6 : Input selection of inverter capacity setting

Input	SW 1-1	SW 1-2	SW 1-3	SW 6-1	SW 6-2	Step for capacity setting
REMOTE SWITCH Type A (4bit-8 setting)	OFF	OFF	OFF	OFF	OFF	See the "Capacity setting" table below.
REMOTE SWITCH Type B (1bit-1 setting)	ON	OFF	OFF	OFF	OFF	
Analog (4-20mA)	ON	ON	OFF	ON	ON	
Analog (1-5V)	ON	ON	OFF	OFF	ON	
Analog (0-10V)	OFF	OFF	ON	OFF	OFF	
Analog (0-10kΩ)	ON	OFF	ON	OFF	OFF	
No input (Auto step mode)	OFF	ON	ON	OFF	OFF	Only Auto step mode
Modbus	ON	ON	ON	OFF	OFF	OFF/Step1/Step2/.../Step11

• Capacity setting

Analog input				Step for capacity setting	Remote switch				Step for capacity setting		Remark
Variable resistor (0-10kΩ)	4-20mA	1-5V	0-10V	Analog input	TB 62 10-11 (COM-IN5)	TB 62 10-12 (COM-IN6)	TB 62 10-13 (COM-IN7)	TB 62 10-14 (COM-IN8)	Remote SW (Type A)	Remote SW (Type B)	
OPEN(12kΩ-)	—	—	—	OFF	—	—	—	—	—	—	Stop
10kΩ	—	—	—	Auto	OFF	OFF	OFF	ON	Auto	Auto	Auto step mode
7.5kΩ	19-20mA	4.75-5V	9.75-10V	Step11 max.	ON	ON	ON	OFF	Step11 max.	—	Hz fixed mode
—	—	—	9.02V	Step10	—	—	—	—	—	—	
5.6kΩ	17mA	4.25V	8.20V	Step9	OFF	ON	ON	OFF	Step9	—	
4.3kΩ	15mA	3.75V	7.38V	Step8	ON	OFF	ON	OFF	Step8	—	
—	—	—	6.56V	Step7	—	—	—	—	—	—	
3.3kΩ	13mA	3.25V	5.75V	Step6	OFF	OFF	ON	OFF	Step6	Step11 max.	
—	—	—	4.93V	Step5	—	—	—	—	—	—	
2kΩ	11mA	2.75V	4.11V	Step4	ON	ON	OFF	OFF	Step4	—	
1kΩ	9mA	2.25V	3.29V	Step3	OFF	ON	OFF	OFF	Step3	Step6	
—	—	—	2.47V	Step2	—	—	—	—	—	—	
510Ω	7mA	1.75V	1.66V	Step1 min.	ON	OFF	OFF	OFF	Step1 min.	Step1 min.	
0-100Ω	4-5mA	0-1.25V	0-0.63V	OFF	OFF	OFF	OFF	OFF	OFF	OFF	Stop

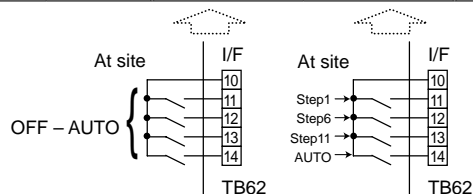

4. Electrical work

• 4-20mA / 1-5V / 0-10V / 0-10kΩ

① Use 4-20mA / 1-5V / 0-10V

Connect the transmission cables to No. 11 and 12 on the terminal block (TB61).
No. 11 on the terminal block(TB62) : Plus side
No. 12 on the terminal block(TB62) : Minus side (Reference side)

② Use variable resistor (0-10kΩ)

Connect the transmission cables to No. 9 and 10 on the terminal block (TB61).

Note:

The values of the "capacity setting" table on the previous page show the center of the input value.

Cable length: Maximum 10m

• Remote switch Type A (4 bit - 8 setting)/Type B (1 bit - 1 setting)

Demand control is available by connecting remote switches with terminal No.10 - 14.

Make sure to use the non-voltage switch (for the remote switch)

Remote switch cable length : Maximum 10m

Remote switch : Minimum applicable load 12V DC, 1mA

Note:

When using intelligent multiple outdoor unit control function, input the capacity request signal to the main interface which connects to the ref. address 0 outdoor unit.

• External function setting

This function is setting operation mode or stopping compressor, by the external signal.

TB62	Item	OFF	ON	Remark
1-2 (IN1)	Forced Comp. OFF *1	Normal	Forced Comp. OFF	
3-4 (IN2)Item	Fixed operation mode	Cooling	Heating	Available when SW2-1 and SW2-2 are ON

*1 The operation continues during defrosting operation.

The "Forced Comp. OFF" signal should not be turned ON frequently. It should only be used if an abnormality occurs.

Cable length : Maximum 10m

Remote switch : Minimum applicable load 12V DC, 1mA

Note:

When using IN1 with intelligent multiple outdoor unit control function, input IN1 to the interface unit respectively. Input IN2 to the main interface which connects to the ref. address 0 outdoor unit.

⚠ Caution:

The external input signals are separated by basic insulation from power supply for the unit.

The external input signals should be separated by supplementary insulation from where user may touch in case that it is installed where user may touch. Connect the terminals by using the ring terminals and also insulate the cables of adjoining terminals when wiring to terminal block.

4.1.5. Connecting External Output

Name	Terminal block	Item	OFF	ON
OUT1	TB141 5-6	Operation Output	OFF	ON
OUT2	TB141 3-4	Error Output	Normal	Error
OUT3	TB141 1-2	Comp. ON Output	OFF(Comp. OFF)	ON(Comp. ON)
OUT4	TB142 5-6	Defrost Output	OFF	ON(Defrosting)
OUT5	TB142 3-4	Mode(Cool) Output	OFF	ON(Cooling)
OUT6	TB142 1-2	Mode(Heat) Output	OFF	ON(Heating)
OUT7	TB143 5-6	Self protection Output	OFF	ON
OUT8	TB143 3-4	Pre-Defrost Output *1	OFF	ON

*1 The output may not be available depending on connected outdoor unit models.

Cable length : Maximum 50m

Output specification : Non-voltage switch 1A, 240V AC/30V DC or less
10 mA, 5 V DC or more

*Connect the surge absorber according to the load at site.

Note:

• External output signals are separated by basic insulation from other circuit of interface.

• When intelligent multiple outdoor unit control function is selected, OUT2, OUT3, OUT4, OUT7 and OUT8 will work individually on each interface.

⚠ Caution: When 2 or more external outputs are used, the power supply on the output side should be the same.

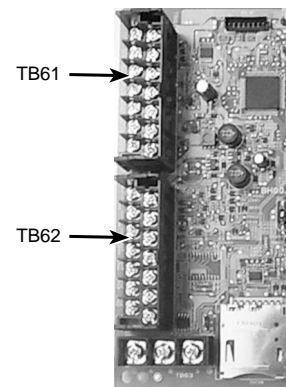

<Photo 4.1.4>

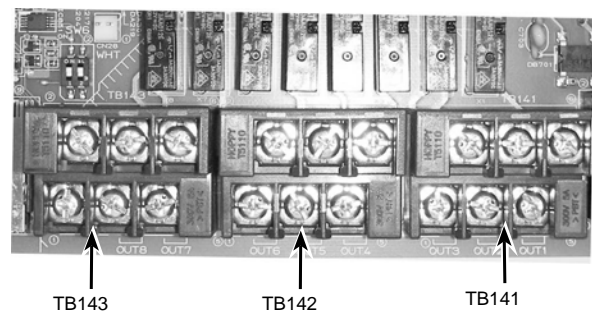
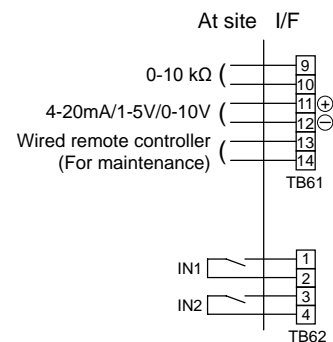

<Photo 4.1.5>

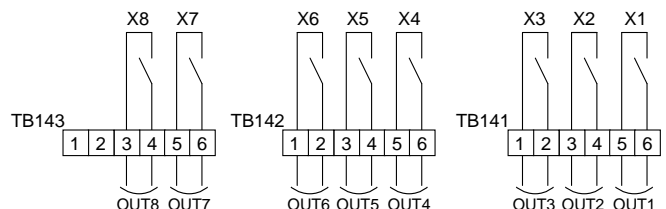

4. Electrical work

4.1.6. Wiring specification External output / External input

Locally supplied parts

Item	Name	Model and specifications
External output function	External output signal wire	Use sheathed vinyl coated cord or cable. Wire type : CV, CVS or equivalent. Wire size : Stranded wire 0.5mm ² to 1.25mm ² Solid wire: ϕ 0.65mm to ϕ 1.2mm
	Display lamp, etc.	Non-voltage Contact 220-240V AC (30V DC), 1A or less 10 mA, 5 V DC or more
External input function	External input signal wire	Use sheathed vinyl coated cord or cable. Wire type : CV, CVS or equivalent. Wire size : Stranded wire 0.5mm ² to 1.25mm ² Solid wire : ϕ 0.65mm to ϕ 1.2mm
	Switch	Non-voltage "a" contact

4.1.7. Switch setting

It is possible to set the following function by setting the switch of the interface controller.

• SW2-1/2-2 : Fixed operation mode

SW2-1	SW2-2	Details
OFF	OFF	Not FIX (Depending on Remote controller setting)
ON	OFF	[Cooling] FIX
OFF	ON	[Heating] FIX
ON	ON	External input (Depending on TB62 3-4)

• SW2-3/2-4/2-5 : Fixed set temperature [For Auto step mode only]

SW2-3	SW2-4	SW2-5	Details
OFF	OFF	OFF	Not fixed (Remote controller setting)
ON	OFF	OFF	Cooling 19°C/Heating 17°C FIX
OFF	ON	OFF	20°C FIX
ON	ON	OFF	22°C FIX
OFF	OFF	ON	24°C FIX
ON	OFF	ON	26°C FIX
OFF	ON	ON	28°C FIX
ON	ON	ON	Cooling 30°C/Heating 28°C FIX

Set switches in case of auto step mode.

• SW3-4/3-5 : Thermo OFF point by HEX inlet air temp.

(difference between target temp. and HEX inlet temp.)

[For Auto step mode and supply air temp. control]

Compressor is forced to stop when HEX inlet temp. is close to target temp. to reduce frequent ON/OFF cycling under low heating/cooling load condition.

SW3-4	SW3-5	Differential
OFF	OFF	1°C
OFF	ON	2°C
ON	OFF	3°C ^{*1}
ON	ON	4°C

*1. Standard setting : 3°C

• Other DIP switch setting

DIP switch	Function	OFF	ON
SW1-4	HEX inlet temp. thermistor (TH11) ^{*2}	WITH	WITHOUT
SW1-5	2-phase temp. thermistor (TH5)	WITH	WITHOUT
SW1-6	Time stamp function on SD card data	Not available	Available ^{*1}
SW1-7	Position of target temp. thermistor (TH1)	Supply Air temp. control	Return Air temp. control
SW1-8	Intelligent multiple outdoor units control	Inactive	Active
SW2-6	LEV self control ^{*2}	OFF	ON
SW2-7	Ref. liquid temp. thermistor (TH2) ^{*2}	WITH	WITHOUT
SW2-8	Target temp. thermistor (TH1)	WITH	WITHOUT

*1. This function is valid only with remote controller.

*2. This SW must be set to "OFF".

4.1.8. Before test run

After completing installation and the wiring and piping of the local application and outdoor units, check for refrigerant leakage, looseness in the power supply or control wiring, wrong polarity, and no disconnection of one phase in the supply.

Use a 500-volt megohmmeter to check that the resistance between the power supply terminals and ground is at least 1.0M Ω .

⚠ Warning:

Do not use the system if the insulation resistance is less than 1.0M Ω .

⚠ Caution:

Do not carry out this test on the control wiring (low voltage circuit) terminals.

4. Electrical work

4.2 Using SD memory card

The interface unit is equipped with an SD memory card interface. Using an SD memory card can store operating logs.

- (a) For insertion, push on the SD memory card until it clicks into place.
 (b) For ejection, push on the SD memory card until it clicks.

Note: To avoid cutting fingers, do not touch sharp edges of the SD memory card connector (CN108) on the interface controller.

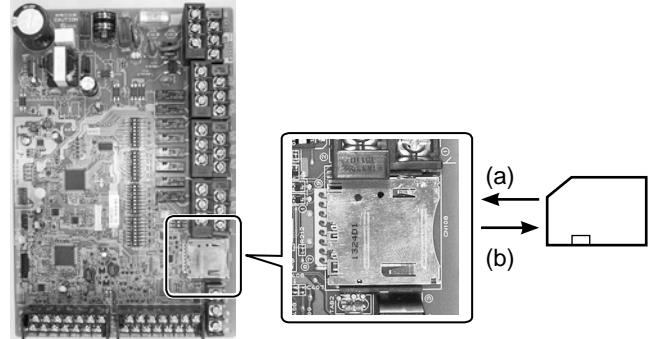

<Handling precautions>

- (1) Use an SD memory card that complies with the SD standards. Check that the SD memory card has a logo on it of those shown to the right.
- (2) SD memory cards to the SD standards include SD, SDHC, miniSD, micro SD, and microSDHC memory cards. The capacities are available up to 32 GB. Choose that with a maximum allowable temperature of 55°C.
- (3) When the SD memory card is a miniSD, miniSDHC, microSD, or micro SDHC memory card, use an SD memory card converter adapter.
- (4) Before writing to the SD memory card, release the write-protect switch.



- (5) Before inserting or ejecting an SD memory card, make sure to power off the system. If an SD memory card is inserted or ejected with the system powered on, the stored data could be corrupted or the SD memory card be damaged. *An SD memory card is live for a short duration after the system is powered off. Before insertion or ejection wait until the LED lamps on the interface control board are all off.
- (6) The read and write operations have been verified using the following SD memory cards, however, these operations are not always guaranteed as the specifications of these SD memory cards could change.

Manufacturer	Model	Tested in
Verbatim	#44015 0912-61	Mar. 2012
SanDisk	SDSDB-002G-B35	Oct. 2011
Panasonic	RP-SDP04GE1K	Oct. 2011
Arvato	2GB PS8032 TSB 24nm MLC	Jun. 2012
Arvato	2GB PS8035 TSB A19nm MLC	Jul. 2014
Lexar	LSD 8GB ABEUCL6 Rev A	Jul. 2014

Before using a new SD memory card, always check that the SD memory card can be safely read and written to by the interface board.

<How to check read and write operations>

- a) Check for correct wiring of power supply to the system. For more details, refer to section 4.1.
 (Do not power on the system at this point.)
 - b) Insert an SD memory card.
 - c) Power on the system.
 - d) The LED6 lamp lights if the read and write operations are successfully completed. If the LED6 lamp continues blinking or does not light, the SD memory card cannot be read or written to by the interface controller.
- (7) Make sure to follow the instruction and the requirement of the SD memory card's manufacturer.
 - (8) Format the SD memory card if determined unreadable in step (6). This could make it readable.
 - (9) Interface board supports FAT file system but not NTFS file system.
 - (10) Mitsubishi Electric is not liable for any damages, in whole or in part, including failure of writing to an SD memory card, and corruption and loss of the saved data, or the like. Back up saved data as necessary.
 - (11) Do not touch any electronic parts on the interface controller when inserting or ejecting an SD memory card, or else the control board could fail.

Logos
Capacities
2 GB to 32 GB *1
SD speed classes
All

- * The SD Logo is a trademark of SD-3C, LLC.
 The miniSD logo is a trademark of SD-3C, LLC.
 The microSD logo is a trademark of SD-3C, LLC.

*1 A 2-GB SD memory card stores up to 30 days of operation logs.

4. Electrical work

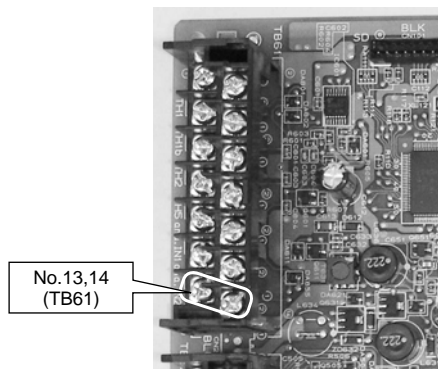

<Fig. 4.3.1>

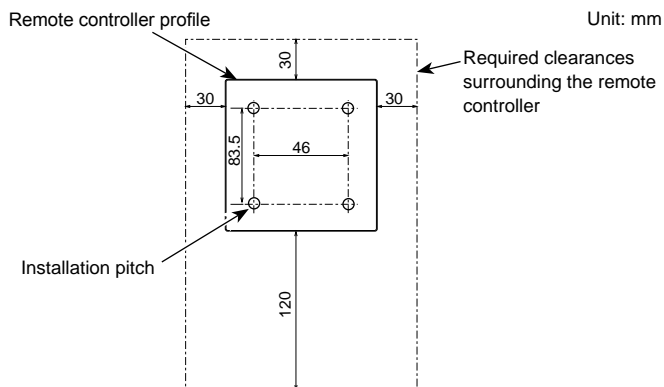

<Fig. 4.3.2>

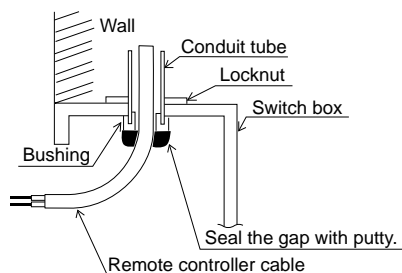

<Fig. 4.3.3>

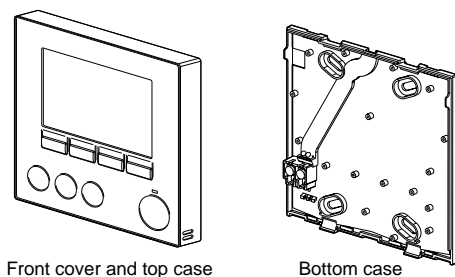

<Fig. 4.3.4>

4.3. Connecting the remote controller

4.3.1. Connect the remote controller cable to Interface unit

Connect the remote controller cable to 13 and 14 on the terminal block (TB61) on the interface controller. <Fig. 4.3.1>

Wiring wire No. x size (mm²): 2 x 0.3 (non polar)

The 5 m wire is attached as an accessory. Max. 500 m

Wiring size must comply with the applicable local and national codes.

Circuit rating: 12V DC

Circuit rating is NOT always against the ground.

Notes:

Wiring for remote controller cable shall be (5 cm or more) apart from power source wiring so that it is not influenced by electric noise from power source wiring. (Do not insert the remote controller cable and power source wiring in the same conduit.) (Refer to Fig. 4.1.1)

When wiring to TB61, use the ring type terminals and insulate them from the cables of adjoining terminals.

4.3.2. Installing the remote controller

1. The remote controller can be installed either in the switch box or directly on the wall. Perform the installation properly according to the method.

(1) Secure clearances shown in <Fig. 4.3.2> regardless of whether installing the remote controller either directly on the wall or in the switch box.

(2) Prepare the following items in the field.

- Double switch box
- Thin metal conduit
- Locknut and bushing
- Cable cover
- Wall plug

2. Drill an installation hole in the wall.

- Installation using a switch box
 - Drill a hole in the wall for the switch box, and install the switch box in the hole.
 - Fit the conduit tube into the switch box.

- Direct wall installation
 - Drill a cable access hole and thread the remote controller cable through it.

⚠ Caution:

To prevent entry of dew, water, and insects, seal the gap between the cable and the hole through which the cable is threaded with putty. Otherwise, electric shock, fire, or failure may result.

3. Have the remote controller ready.

Remove the bottom case from the remote controller.

4. Connect the remote controller cable to the terminal block on the bottom case.

Modify the remote controller cable as shown in <Fig. 4.3.5>, and thread the cable from behind the bottom case.

Completely thread the cable to the front so that the unsheathed part of the cable cannot be seen behind the bottom case.

Connect the remote controller cable to the terminal block on the bottom case.

- Direct wall installation
 - Seal the gap between the cable and the hole through which the cable is threaded.

⚠ Caution

To prevent electric shock or failure, keep the sheath ends or any other foreign objects out of the terminal block.

Do not use ring terminals to connect the wires to the terminal block on the bottom case. The terminals will come in contact with the control board and the front cover and top case, which will result in failure.

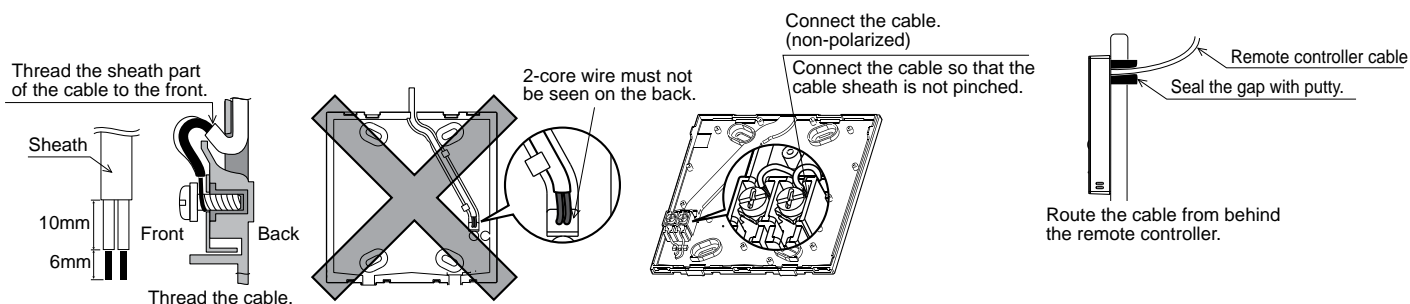

<Fig. 4.3.5>

4. Electrical work

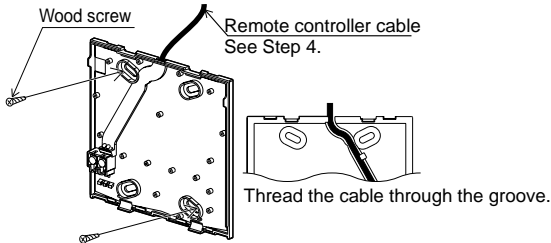
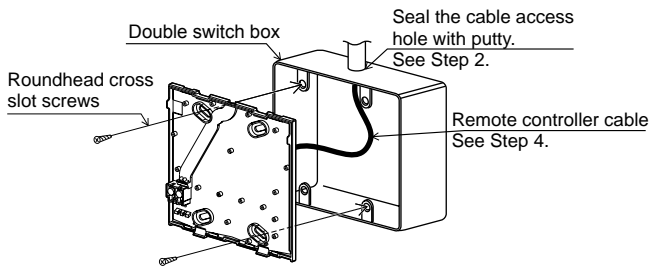

<Fig. 4.3.6>

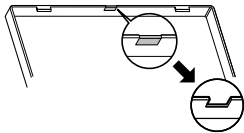

<Fig. 4.3.7>

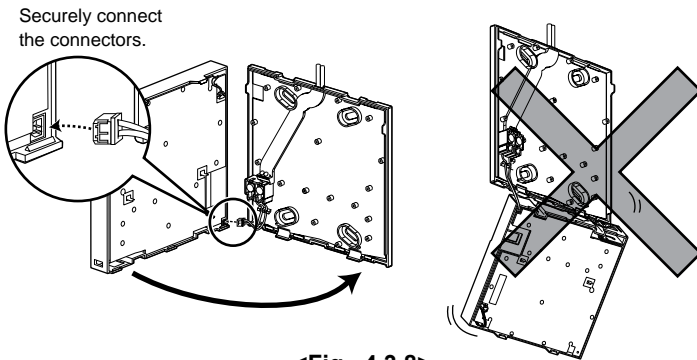

<Fig. 4.3.8>

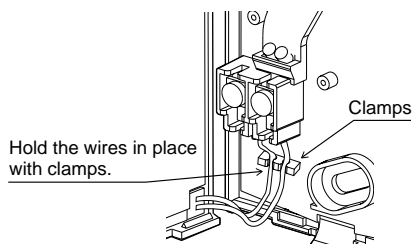

<Fig. 4.3.9>

5. Install the bottom case.

- Installation using a switch box
 - When installing the bottom case in the switch box, secure at least two corners of the switch box with screws.

■ Direct wall installation

- Thread the cable through the slot provided.
- When mounting the bottom case on the wall, secure at least two corners of the remote controller with screws.
- To prevent the bottom case from lifting, use top-left bottom-right corners of the remote controller (viewed from the front) to secure the bottom case to the wall with wall plugs or the like.

⚠ Caution:

To avoid causing deformation or cracks to the remote controller, do not overtighten the screws and make an additional installation hole(s).

6. Cut out the cable access hole.

■ Direct wall installation

- Cut out the knockout hole (indicated with grey in <Fig. 4.3.7>) in the front cover by knife or nipper.
- Thread the remote controller cable from the slot behind the bottom case through this access hole.

7. Plug the lead wire cable into the top case.

- Plug the lead wire cable coming from the bottom case into the top case.

⚠ Caution:

To avoid failures, do not remove the controller board protective sheet and the controller board from the top case.

After the cable is plugged into the top case, do not hang the top case as shown in <Fig. 4.3.8>. Otherwise, the remote controller cable could sever, which could cause malfunction to the remote controller.

8. Fit the lead wires into the clamps.

⚠ Caution:

Hold the wires in place with clamps to prevent excessive strain from being applied on the terminal block and causing cable breakage.

4. Electrical work

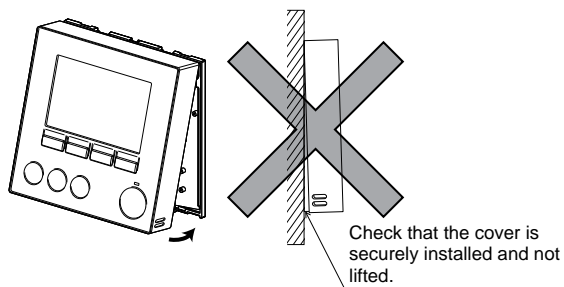

<Fig. 4.3.10>

Seal the gap between the cable and the access hole with putty.

Use a cable cover.

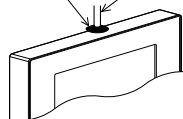

Thread the remote controller cable through the cable access hole at the top of the remote controller.

<Fig. 4.3.11>

9. Fit the top case and the front cover onto the bottom case.

The top case assembly (fitted with the front cover at factory shipment) has two tabs on top. Hook the tabs onto the bottom case and snap the top case onto the bottom case into place. Check that the cover is securely installed.

⚠ Caution:

When the top case is correctly attached to the bottom case a click is heard. If the front cover is not clicked into place it may fall off.

- Direct wall installation (when routing the remote controller cable along the wall surface)
 - Thread the remote controller cable through the cable access hole at the top of the remote controller.
 - Seal the gap between the cable and the access hole with putty.
 - Use a cable cover.

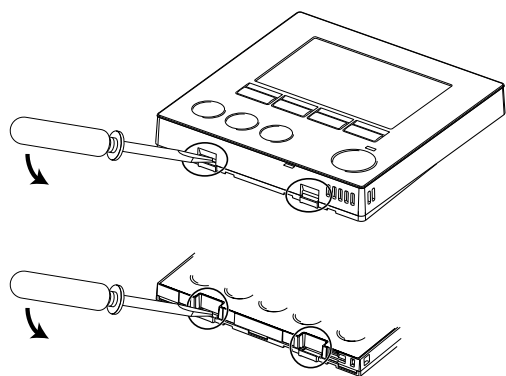

<Fig. 4.3.12>

● Disassembling the top case and the front cover

(1) Remove the front cover.

Insert a flat head screwdriver into either of two open slots at the bottom of the remote controller and move the screwdriver handle downward as shown. The engagement of the tabs will be released. Then pull the front cover toward the front to remove the front cover.

(2) Remove the top case.

Insert a flat head screwdriver into either of two open slots at the bottom of the remote controller. The subsequent procedure is the same as that of the front cover.

⚠ Caution:

Use a 5 mm- flat head screwdriver. Do not turn the screwdriver forcibly while placing the blade in the slots. Doing so could break the covers.

5. Remote controller operation

■ Disposal of the Unit



<Figure 5.1>

Note: This symbol mark is for EU countries only.

This symbol mark is according to the directive 2012/19/EU Article 14 Information for users and Annex IX, and/or to the directive 2006/66/EC Article 20 Information for end-users and Annex II.

Your Mitsubishi Electric heating system products have been manufactured with high quality materials and components which can be recycled and/or reused. The symbol in Figure 5.1 means that electrical and electronic equipment, batteries and accumulators at the end of their life, should be disposed of separately from your household waste.

If a chemical symbol is printed beneath the symbol (Figure 5.1), this chemical symbol means that the battery or accumulator contains a heavy metal at a certain concentration. This is indicated as follows;

Hg: mercury (0.0005%), Cd: (cadmium (0.002%), Pb: lead (0.004%)

In the European Union there are separate collection systems for used electrical and electronic products, batteries and accumulators. Please dispose of this equipment, batteries and accumulators correctly at your local community waste collection/recycling centre.

Contact your local Mitsubishi Electric dealer for country-specific details on disposal.

Please, help us to conserve the environment we live in.

5.1. Safety precautions **FOR USER**

- ▶ Before installing the unit, make sure you read all the "Safety Precautions".
- ▶ The "Safety Precautions" provide very important points regarding safety. Make sure you follow them.
- ▶ Please report to or take consent by the supply authority before connection to the system.

Symbols used in the text

⚠ Warning:

Describes precautions that should be observed to prevent danger of injury or death to the user.

⚠ Caution:

Describes precautions that should be observed to prevent damage to the unit.

Symbols used in the illustrations

⚡ : Indicates a part which must be grounded.

⚠ Warning:

- The unit must not be installed by the user. Ask the dealer or an authorized company to install the unit. If the unit is installed improperly, electric shock or fire may result.
- Do not stand on, or place any items on the unit.
- Do not splash water over the unit and do not touch the unit with wet hands. An electric shock may result.
- Do not spray combustible gas close to the unit. Fire may result.
- Do not place a gas heater or any other open-flame appliance where it will be exposed to the air discharged from the unit. Incomplete combustion may result.
- Do not remove the front panel or the fan guard from the outdoor unit when it is running.
- When you notice exceptionally abnormal noise or vibration, stop operation, turn off the power switch, and contact your dealer.

- Never insert fingers, sticks etc. into the intakes or outlets.
- If you detect odd smells, stop using the unit, turn off the power switch and consult your dealer. Otherwise, a breakdown, electric shock or fire may result.
- If the supply cable is damaged, it must be replaced by the manufacturer, its service agent or similarly qualified persons in order to avoid a hazard.
- This appliance is not intended for use by persons (including children) with reduced physical, sensory or mental capabilities, or lack of experience and knowledge, unless they have been given supervision or instruction concerning use of the appliance by a person responsible for their safety.
- Children should be supervised to ensure that they do not play with the appliance.
- If the refrigeration gas blows out or leaks, stop the operation of the air conditioner, thoroughly ventilate the room, and contact your dealer.
- Do not install in location that is hot or humid for long periods of time.

⚠ Caution:

- Do not use any sharp object to push the buttons, as this may damage the remote controller.
- Never block or cover the interface unit's intakes or outlets.

Disposing of the unit

When you need to dispose of the unit, consult your dealer.

5. Remote controller operation

5.2. Names and functions of controller components

Display

The main display can be displayed in two different modes: "Full" and "Basic."
The factory setting is "Full."

Full mode

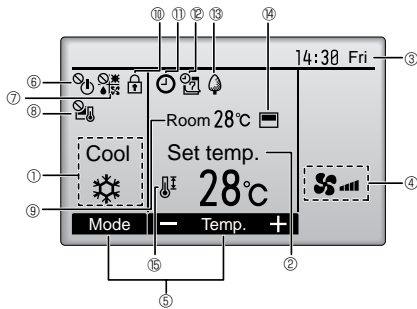

Basic mode

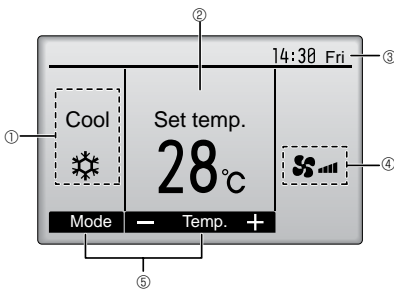

* All icons are displayed for explanation.

- ① Operation mode**
Interface unit operation mode appears here.
- ② Preset temperature**
Preset temperature appears here.
- ③ Clock**
Current time appears here.
- ④ Fan speed**
This function is not available.
- ⑤ Button function guide**
Functions of the corresponding buttons appear here.
- ⑥**
Appears when the ON/OFF operation is centrally controlled.
- ⑦**
Appears when the operation mode is centrally controlled.
- ⑧**
Appears when the preset temperature is centrally controlled.
- ⑨ Room temperature**
Current room temperature appears here.
- ⑩**
Appears when the buttons are locked.
- ⑪**
Appears when the On/Off timer function is enabled.
- ⑫**
Appears when the Weekly timer is enabled.
- ⑬**
Appears while power is ON.
- ⑭**
Appears when the built-in thermistor on the remote controller is activated to monitor the room temperature (⑨).
Appears when the thermistor on the interface unit is activated to monitor the room temperature.
- ⑮**
Appears when the preset temperature range is restricted.

Controller interface

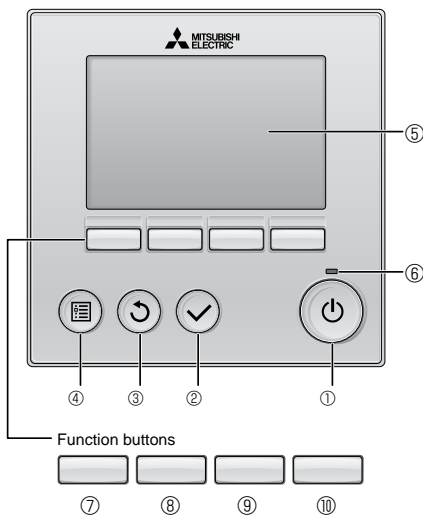

- When the backlight is off, pressing any button turns the backlight on and does not perform its function. (except for the ON/OFF button)
- Most settings (except ON/OFF, mode, fan speed, temperature) can be made from the Menu screen.

- ① ON/OFF button**
Press to turn ON/OFF the interface unit.
 - ② SELECT button**
Press to save the setting.
 - ③ RETURN button**
Press to return to the previous screen.
 - ④ MENU button**
Press to bring up the Main menu.
 - ⑤ Backlit LCD**
Operation settings will appear. When the backlight is off, pressing any button turns the backlight on and it will stay lit for a certain period of time depending on the screen.
 - ⑥ ON/OFF lamp**
This lamp lights up in green while the unit is in operation. It blinks while the remote controller is starting up or when there is an error.
- The functions of the function buttons change depending on the screen. Refer to the button function guide that appears at the bottom of the LCD for the functions they serve on a given screen. When the system is centrally controlled, the button function guide that corresponds to the locked button will not appear.
- Main display**

Main menu
- Function guide
- ⑦ Function button [F1]**
Main display: Press to change the operation mode.
Main menu: Press to move the cursor down.
 - ⑧ Function button [F2]**
Main display: Press to decrease temperature.
Main menu: Press to move the cursor up.
 - ⑨ Function button [F3]**
Main display: Press to increase temperature.
Main menu: Press to go to the previous page.
 - ⑩ Function button [F4]**
Main display: Not available.
Main menu: Press to go to the next page.

5. Remote controller operation

5.3. Initial settings

From the Main display, press "MENU" button, select "Initial setting", and make the remote controller settings on the screen that appears.

- Main/Sub
- Clock
- Main display
- Contrast
- Display details
 - Clock
 - Temperature
 - Room temp.
 - Auto mode (Auto cooling/heating operation)
- Auto mode (Auto cooling/heating operation)
- Administrator password
- Language selection

(1) Main/Sub setting

When connecting two remote controllers, one of them needs to be designated as a sub controller.

(2) Clock setting

Clock setting is necessary for time display, SD card data logging, weekly timer, timer setting and error history.

Make sure to perform clock setting when the unit is used for the first time or has not used for a long time.

(3) Main display setting

Use the F3 or F4 button to select the display mode "Full" or "Basic." (The factory setting is "Full.")

(4) Remote controller display details setting

Make the settings for the remote-controller-related items as necessary.

Press the SELECT button to save the changes.

[1] Clock display

[2] Temperature unit setting

[3] Room temperature display

[4] Auto mode (Auto cooling/heating operation) display setting

(The factory setting is "Yes".)

· Yes: "AUTO COOL" or "AUTO HEAT" is displayed during Auto mode (Auto cooling/heating operation).

· No: Only "AUTO" is displayed during Auto mode (Auto cooling/heating operation).

(5) Auto mode (Auto cooling/heating operation) setting

· Yes: The Auto mode (Auto cooling/heating operation) can be selected in the operation mode setting.

· No: The Auto mode (Auto cooling/heating operation) cannot be selected in the operation mode setting.

(The factory setting is "Yes".)

(6) Administrator password setting

• The initial administrator password is "0000." Change the default password as necessary to prevent unauthorized access. Have the password available for those who need it.

• If you forget your administrator password, you can initialize the password to the default password "0000" by pressing and holding the F1 and F2 buttons simultaneously for three seconds on the administrator password setting screen.

• The administrator password is required to make the settings for the following items.

- Timer setting
- Weekly timer setting
- Restriction setting

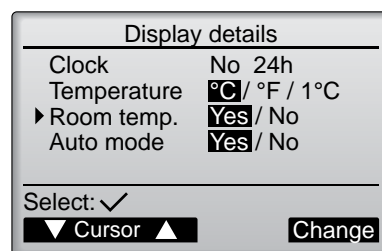

5. Remote controller operation

5.4. Basic operations

■ Operation mode icons

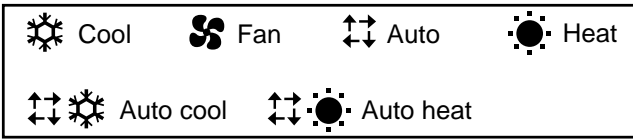

■ Turning ON and selecting operation mode

1 Press button ① ([ON/OFF]).

2 Press button ⑦ ([F1]) to go through the operation modes.



The ON/OFF lamp and the LCD will light up.

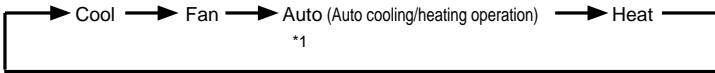

*1 Operation mode is available ONLY when input selection of capacity setting (DIP SW1 and SW6) is "No input (Auto step mode)" and Return air temp. control is selected (DIP SW 1-7 is ON).

■ Preset temperature setting

Press button ⑧ ([F2]) to decrease the preset temperature.

Press button ⑨ ([F3]) to increase the preset temperature.

* Pressing once changes the value by 1°C (1°F).

Operation mode	Preset temperature range
Cool (Supply air temp. control)	12 – 30 °C (54 – 87 °F)
Cool (Return air temp. control)	19 – 30 °C (67 – 87 °F)
Heat	17 – 28 °C (63 – 83 °F)
Auto cooling/heating operation	19 – 28 °C (67 – 83 °F)
Fan	Not settable

* The temperature range restriction setting will be applied preferentially, if any. If the setting value is outside of the range, a message "Temp. range locked" will appear.

■ Automatic cooling/heating operation

1 Press button ① ([ON/OFF]).

2 Press button ⑦ ([F1]) to display the operation mode "Auto".



When the room temperature is higher than the preset temperature, cooling operation starts.
When the room temperature is lower than the preset temperature, heating operation starts.

* The current operation mode ("Auto cool" or "Auto heat") will be displayed after the mode is determined.

If "Display/non-display of COOL/HEAT during AUTO mode" has been set to "Non-display" while making the initial settings, only "Auto" will be displayed.

5.5. Troubleshooting

When an error occurs, the following screen will appear.
Check the error status, stop the operation, and consult your dealer.

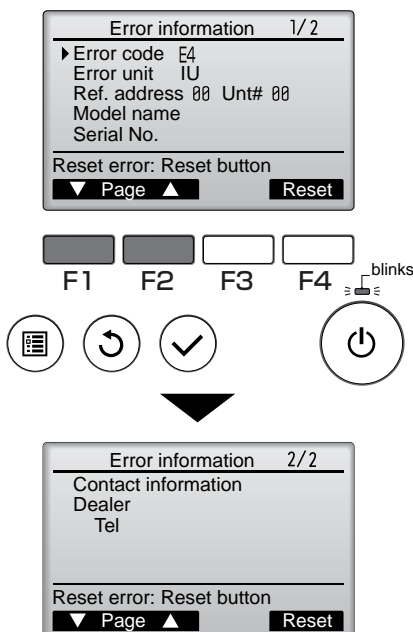

Error code, error unit, refrigerant address, unit model name, and serial number will appear.

The model name and serial number will appear only if the information have been registered.

Press button ⑦ ([F1]) or ⑧ ([F2]) to go to the next page.

Contact information (dealer's phone number) will appear if the information have been registered.

5. Remote controller operation

5.6. Timer and Weekly timer

The settings for Timer and Weekly timer operation can be made from the remote controller.

Press button ④ ([MENU]) to go to the Main menu, and move the cursor to the desired setting with button ⑦ ([F1]) or ⑧ ([F2]).

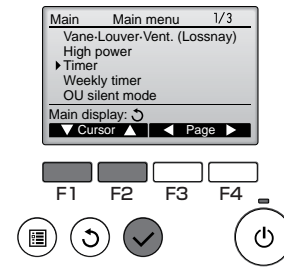

■ Timer

- On/Off timer
Operation On/Off times can be set in 5-minute increments.
- Auto-Off timer
Auto-Off time can be set to a value from 30 to 240 in 10-minute increments.

■ Weekly timer

Operation On/Off times for a week can be set.
Up to eight operation patterns can be set for each day.

5.7. Service

■ Maintenance password setting

- The initial administrator password is "9999". Change the default password as necessary to prevent unauthorized access. Have the password available for those who need it.
- If you forget your administrator password, you can initialize the password to default password "9999" by pressing and holding the F1 and F2 buttons simultaneously for three seconds on the maintenance password setting screen.

5.8. Others

The following functions are NOT available.

(1) In main menu (Press button ④ ([MENU]), main menu appears.)

- "Vane Louver Vent (Lossnay)"
- "High power"
- "OU silent mode"
- In "Energy saving" menu, "schedule" function is NOT available.
- "Filter information"
- "Maintenance"
- In "Service" menu, "Drain pump test run", "Check" functions are NOT available, except for "Request code" in "Check" function.

6. Service and Maintenance

■ Error Codes

Code	Error	Action
P1	Target air temperature thermistor (TH1) failure	<ul style="list-style-type: none"> • Check connection of thermistor. • Check resistance value of thermistor. 0°C 15.0 kΩ 10°C 9.6 kΩ 20°C 6.3 kΩ 30°C 4.3 kΩ
P2	Ref. liquid temperature thermistor (TH2) failure	<ul style="list-style-type: none"> • Check connection of thermistor. • Check resistance value of thermistor. For characteristics, refer to (P1) above.
P6	Freezing/ overheating protection	<ul style="list-style-type: none"> • Check local system if air flow is reduced. • Check outdoor fan motor.
P9	2-Phase temperature thermistor (TH5) failure	<ul style="list-style-type: none"> • Check connection of thermistor. • Check resistance value of thermistor. For characteristics, refer to (P1) above.
E0 - E5	Communication failure between remote controller and interface controller board	<ul style="list-style-type: none"> • Check connection cable for damage or loose connections. • Check system configuration of remote controller. (Refer to "3. System")
E6 - E7	Communication failure between interface unit and outdoor unit	<ul style="list-style-type: none"> • Check that outdoor unit has not been turned off. • Check connection cable for damage or loose connections. • Refer to outdoor unit service manual.
Fb	Interface controller board failure	<ul style="list-style-type: none"> • Replace interface controller board.
PL	Abnormal refrigerant circuit	<ul style="list-style-type: none"> • Replace the 4-way valve. • Check refrigerant pipes for disconnection or leakage. • Refer to outdoor unit service manual.
PU	HEX inlet temperature thermistor (TH11) failure	<ul style="list-style-type: none"> • Check connection of thermistor. • Check resistance value of thermistor. For characteristics, refer to (P1) above.
"EE" or "System error 1"	DIP SW setting error (Intelligent multiple outdoor unit controll)	<ul style="list-style-type: none"> • Set DIP SW 1-8 to "OFF", if system is single outdoor unit control. • Connect between interface units and set Ref. address of each outdoor unit. (See "3. System".)
System error 2	Controller board is incompatible with this model.	<ul style="list-style-type: none"> • Install interface controller board that is compatible with PAC-IF013B-E or PAC-SIF013B-E.
System error 3	Incompatible controller board is mixed when multiple interface units are connected.	<ul style="list-style-type: none"> • Check all interface controller boards are compatible with PAC-IF013B-E or PAC-SIF013B-E.
System error 4	DIP SW 1-8 of some interface units are ON and those of the other interface units are OFF.	<ul style="list-style-type: none"> • Set DIP SW 1-8 of all interface units to ON, or SW1-8 of all interface units to OFF.
"System error 5" or "System error 6"	2 or more Interface units are connected with one remote controller and manual step mode is selected, but DIP SW1-8 are OFF.	<ul style="list-style-type: none"> • Set SW1-8 of all interface units to ON if system is intelligent multiple outdoor unit controll. • Disconnect between interface units and connect remote controllers separately to each interface unit, if manual step mode is selected and intelligent multiple outdoor unit control is not selected.
System error 11	7 or more interface units are connected. (Up to 6 interface units can be connected.)	<ul style="list-style-type: none"> • Connect 6 or less interface units in one system.
"6831" or "Please wait" remains displayed on the remote controller for more than 6 minutes.	Remote controller is incompatible with this model.	<ul style="list-style-type: none"> • Remote controller included in the package of PAC-IF013B-E is exclusive for PAC-IF013B-E or PAC-SIF013B-E. Use the remote controller that has a drawing number "BH00J360" on the bottom.

7. Requirement on local design

- This interface is to connect Mr. Slim inverter outdoor unit of MITSUBISHI ELECTRIC to local applications. Please check the following when designing the local system.
- MITSUBISHI ELECTRIC does not take any responsibility on the local system design. Therefore, MITSUBISHI ELECTRIC does NOT take any responsibility on the failure (including outdoor unit) caused by local AHU and system design.
- Conformity of regulations and laws must be confirmed on the system on your side.

7.1. Air flow volume

Standard air flow volume

Model capacity of outdoor unit	ZRP	35	50	60	71	100	125	140	200	250
	P	–	–	–	–	–	–	–	200	250
	SHW	–	–	–	80	112	140	–	230	–
Maximum air volume	[m ³ /min]	12.3	18	21	24	33.6	42	48	67.2	81
	[m ³ /h]	738	1080	1260	1440	2016	2520	2880	4032	4860
Minimum air volume	[m ³ /min]	6.2	8.6	10.5	12.2	16.3	21.5	23.0	32.6	37.8
	[m ³ /h]	372	516	630	732	978	1290	1380	1956	2268

Make sure to keep the air flow volume within the limits of maximum and minimum below.

(1) Maximum air volume

Step mode	Number of outdoor unit	Capacities of the connected outdoor units	Maximum air volume
Manual	2-6	The same	500% of selected outdoor unit's maximum standard air volume ^{*1}
		Different	If smaller capacity outdoor unit's rated heating capacity is under 20% of total heating capacity, 500% of bigger capacity outdoor unit's maximum standard air volume is allowable. If smaller capacity outdoor unit's rated heating capacity is 20% or more of total heating capacity, 500% of smaller capacity outdoor unit's maximum standard air volume is allowable.
	1	–	200% of selected outdoor unit's maximum standard air volume
Auto	2-5	–	500% of the smallest capacity outdoor unit's maximum standard air volume
	1	–	200% of selected outdoor unit's maximum standard air volume

*1. 600% of selected outdoor unit's maximum standard air volume is available ONLY when 6 same capacity outdoor units are connected.

Note:

- When multiple outdoor units are connected, basically select one interlaced heat exchanger which has multiple refrigerant circuit or multiple heat exchanger placed in parallel to the air flow. If multiple heat exchangers placed in series with the air flow have to be used, maximum 2 heat exchanger in series are acceptable.

(2) Minimum air volume

Total amount of selected outdoor unit's minimum standard air volume is allowable.

7.2. Indoor heat exchanger

(1) Indoor heat exchanger volume

Make sure to keep the HEX capacity within the following range.

If the piping length is 30m or shorter, HEX capacity can be increased as follows.

Model capacity of outdoor unit	ZRP	35	50	60	71	100	125	140	200	250	
	P	–	–	–	–	–	–	–	200	250	
	SHW	–	–	–	80	112	140	–	230	–	
Max. volume [cm ³]	Pipe length	30m -	1050	1500	1800	2130	3000	3750	4200	6000	7500
		20m	1350	1800	2700	3030	3900	4650	5100	7800	9300
		10m	1650	2100	3600	3930	4800	5550	6000	9600	11100
		Min. volume [cm ³]	350	500	600	710	1000	1250	1400	2000	2500

Note: Calculate them by linear interpolation in case of other piping lengths not shown on this table.

(2) Diameter of header

With a bigger size header, the refrigerant flow velocity decreases and this disturbs the sufficient circulation of refrigerant oil. As a result, the refrigerant oil does not flow properly and could cause a serious damage of compressor.

Use the pipe whose outside diameter is less than the value shown in the table below.

Model capacity of outdoor unit	ZRP	35	50	60	71	100	125	140	200	250
	P	–	–	–	–	–	–	–	200	250
	SHW	–	–	–	80	112	140	–	230	–
Max. diameter of header [mm]	φ19					φ28				

(3) Withstanding pressure

Design pressure of outdoor unit is 4.15 MPa. Following must be satisfied for burst pressure of connecting application.

Burst pressure : More than 12.45 MPa (3 times more than design pressure)

(4) Contamination maintenance

1. Wash the inside of heat exchanger to keep it clean. Be sure to rinse not to leave flux. Do not use chlorine detergent when washing.
2. Be sure that the amount of contamination per unit cubic content of heat transfer pipe is less than the following amount.

Example) In case of ø9.52mm

Residual water : 0.6 mg/m, Residual oil : 0.5 mg/m, Solid foreign object : 1.8 mg/m

7. Requirement on local design

7.3. Thermistor position

< Target temp. thermistor (Locally supplied) >

Put thermistor where average supply or return air temperature for heat exchanger can be detected.
Put thermistor where it does NOT pick up the temperature of heat exchanger.

< Liquid refrigerant pipe thermistor (TH2) >

Put thermistor where liquid refrigerant pipe temperature can be detected.
Protect the thermistor with heat insulating materials not to be affected by the ambient temperature, etc.
In case that the refrigerant is distributed by distributor, put thermistor before the distributor.

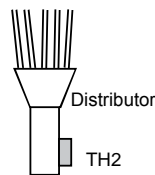

< 2-Phase temp. thermistor (TH5) >

Put thermistor where 2-Phase temperature can be detected on the indoor HEX pipe.
It should be located in the middle of inlet and outlet ports.
If there are some paths, locate it on the top of them.
Protect the thermistor with heat insulating materials not to be affected by the ambient temperature, etc.

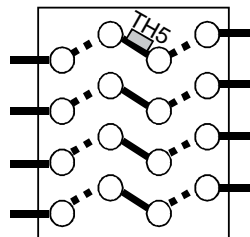

< Target temp. thermistor (TH1) >

Put thermistor where average supply or return air temperature for heat exchanger can be detected.
Put thermistor where it does NOT pick up the temperature of heat exchanger.

< HEX inlet temp. thermistor (TH11) >

Put thermistor where average air temperature of heat exchanger inlet can be detected.
Put thermistor where it does NOT pick up the temperature of heat exchanger.

7.4. Restriction on input signals to the interface unit

Follow the "Note" in section 3.1 and 3.2.

7.5. Indoor operation range

Follow the operation range shown in section 3.3.

mitsubishi electric corporation, shizuoka works
18-1, OSHIKA 3-COME, SURUGA-KU, SHIZUOKA-CITY 422-8528, JAPAN

hereby declares under its sole responsibility that the heating system components described below for use in residential, commercial and light-industrial environments:
erklärt hiermit auf seine alleinige Verantwortung, dass die unten beschriebenen Zubehörteile für das Heizungs- / Kühlungs-System zur Benutzung im häuslichen, kommerziellen und leicht-industriellen Umfeld:
déclare par la présente et sous son entière responsabilité que les composants du système de chauffage/refroidissement décrits ci-dessous pour l'utilisation dans des environnements résidentiels, commerciaux et d'industrie légère :
verklaart hierbij als enige verantwoordelijke dat de componenten van het verwarmings-/koelsysteem die hieronder worden beschreven, bedoeld zijn voor gebruik in woonomgevingen en in commerciële en licht industriële omgevingen.
declara por la presente bajo su responsabilidad exclusiva que los componentes del sistema de calefacción/refrigeración descritos a continuación para su uso en zonas residenciales, comerciales y para la industria ligera:
με το παρόν πιστοποιεί με αποκλειστική της ευθύνη ότι οι τα κλιματιστικά και οι αντλίες θέρμανσης που περιγράφονται παρακάτω για χρήση σε οικιακό, επαγγελματικό και ελαφριάς βιομηχανίας περιβάλλοντα:
con la presente dichiara, sotto la sua esclusiva responsabilità, che i componenti dell'impianto di riscaldamento/raffreddamento descritto di seguito, destinato all'uso in ambienti residenziali, commerciali e industriali:
através da presente declara sob sua única responsabilidade que os componentes do sistema de aquecimento/arrefecimento abaixo descritos para uso residencial, comercial e de indústria ligeira:
erklærer hermed under eneansvar, at de herunder beskrevne komponenter til opvarmning/køling til brug i privat boligbyggeri, erhvervsområder og inden for let industri:
intyggar härmed att uppvärmnings/nedkylningssystemkomponenterna som beskrivs nedan är för användning i bostäder, kommersiella miljöer och lätt industri:
ev, ticaret ve hafif sanayi ortamlarında kullanım amaçlı üretilen ve aşağıda açıklanan klima ve ısıtma pompalarıyla ilgili aşağıdaki hususları yalnızca kendi sorumluluğunda beyan eder:
настоящим заявляет и берет на себя исключительную ответственность за то, что кондиционеры и тепловые насосы, описанные ниже и предназначенные для эксплуатации в жилых помещениях, торговых залах и на предприятиях легкой промышленности:

MITSUBISHI ELECTRIC, PAC-IF013B-E, PAC-SIF013B-E

Note: Its serial number is on the nameplate of the product.
Hinweis: Die Seriennummer befindet sich auf dem Kennschild des Produkts.
Remarque : Le numéro de série de l'appareil se trouve sur la plaque du produit.
Opmerking: het serienummer staat op het naamplaatje van het product.
Nota: El número de serie se encuentra en la placa que contiene el nombre del producto.
Nota: il numero di serie si trova sulla targhetta del prodotto.

Σημείωση: Ο σειριακός του αριθμός βρίσκεται στην πινακίδα ονόματος του προϊόντος.
Nota: o número de série encontra-se na placa que contém o nome do produto.
Bemærk: Serienummeret står på produktets fabriksskilt.
Obs: Serienumret finns på produktens namnplåt.
Not: Seri numarası ürünün isim plakasında yer alır.
Примечание: серийный номер указан на паспортной табличке изделия.

Directives
Richtlijnen
Directives
Richtlijnen
Directivas
Direttive
Οδηγίες
Directivas
Direktiver
Direktiv
Direktivler
Директивы

2006/95/EC: Low Voltage
2004/108/EC: Electromagnetic Compatibility
2011/65/EU: RoHS

Our authorized representative in EU, who is authorized to compile the technical file, is as follows.
Unser autorisierter Vertreter in der EU, der ermächtigt ist die technischen Daten zu kompilieren, ist wie folgt.
Notre représentant agréée dans L'UE, qui est autorisé à compiler le fichier technique, est le suivant.
Onze geautoriseerde vertegenwoordiger in de EU, die gemachtigd is het technische bestand te compileren, is als volgt.
Nuestro representante autorizado en la UE, que está autorizado para compilar el archivo técnico, es el siguiente.
Il nostro rivenditore autorizzato nell'UE, responsabile della stesura della scheda tecnica, è il seguente.

Ο εξουσιοδοτημένος αντιπρόσωπός μας στην ΕΕ, ο οποίος είναι εξουσιοδοτημένος να συντάξει τον τεχνικό φάκελο, είναι ο εξής.
O nosso representante autorizado na UE, que está autorizado para compilar o ficheiro técnico, é o seguinte:
Vores autoriserede repræsentant i EU, som er autoriseret til udarbejdelse af den tekniske fil, er følgende.
Vår EG-representant som är auktoriserad att sammanställa den tekniska filen är följande.
Avrupa Birliği'nde bulunan ve teknik dosyaı düzenleme yetkisine sahip yetkili temsilcimiz aşağıda belirtilmiştir.
Наш авторизованный представитель в ЕС, уполномоченный на составление технического файла, указан ниже.

MITSUBISHI ELECTRIC EUROPE, B.V.
HARMAN HOUSE, 1 GEORGE STREET, UXBRIDGE, MIDDLESEX UB8 1QQ, U.K.
Masahiko KONISHI
Product Marketing Director

This product is designed and intended for use in the residential,
commercial and light-industrial environment.



mitsubishi electric corporation

HEAD OFFICE: TOKYO BLDG., 2-7-3, MARUNOUCHI, CHIYODA-KU, TOKYO 100-8310, JAPAN

Authorised representative in EU: MITSUBISHI ELECTRIC EUROPE B.V.

HARMAN HOUSE, 1 GEORGE STREET, UXBRIDGE, MIDDLESEX UB8 1QQ, U.K.