

# Air-Conditioners OUTDOOR UNIT

## MXZ-8B140,160VA

## MXZ-8B140,160YA



AR46



### INSTALLATION MANUAL

For safe and correct use, please read this installation manual thoroughly before installing the air-conditioner unit.

FOR INSTALLER

### INSTALLATIONSHANDBUCH

Zum sicheren und ordnungsgemäßen Gebrauch der Klimaanlage das Installationshandbuch gründlich durchlesen.

FÜR INSTALLATEURE

### MANUEL D'INSTALLATION

Veillez lire le manuel d'installation en entier avant d'installer ce climatiseur pour éviter tout accident et vous assurer d'une utilisation correcte.

POUR L'INSTALLATEUR

### INSTALLATIEHANDLEIDING

Voor een veilig en juist gebruik moet u deze installatiehandleiding grondig doorlezen voordat u de airconditioner installeert.

VOOR DE INSTALLATEUR

### MANUAL DE INSTALACIÓN

Para un uso seguro y correcto, lea detalladamente este manual de instalación antes de montar la unidad de aire acondicionado.

PARA EL INSTALADOR

### MANUALE DI INSTALLAZIONE

Per un uso sicuro e corretto, leggere attentamente questo manuale di installazione prima di installare il condizionatore d'aria.

PER L'INSTALLATORE

### ΕΓΧΕΙΡΙΔΙΟ ΟΔΗΓΙΩΝ ΕΓΚΑΤΑΣΤΑΣΗΣ

Για ασφάλεια και σωστή χρήση, παρακαλείστε διαβάσετε προσεκτικά αυτό το εγχειρίδιο εγκατάστασης πριν αρχίσετε την εγκατάσταση της μονάδας κλιματισμού.

ΓΙΑ ΑΥΤΟΝ ΠΟΥ ΚΑΝΕΙ ΤΗΝ ΕΓΚΑΤΑΣΤΑΣΗ

### MANUAL DE INSTALAÇÃO

Para segurança e utilização correctas, leia atentamente este manual de instalação antes de instalar a unidade de ar condicionado.

PARA O INSTALADOR

### INSTALLATIONSMANUAL

Læs venligst denne installationsmanual grundigt, før De installerer aircondition anlægget, af hensyn til sikker og korrekt anvendelse.

TIL INSTALLATØREN

### INSTALLATIONSMANUAL

Läs denna installationsmanual noga för säkert och korrekt bruk innan luftkonditioneringen installeras.

FÖR INSTALLATÖREN

### MONTAJ ELKİTABI

Emniyetli ve doğru biçimde nasıl kullanılacağını öğrenmek için lütfen klima cihazını monte etmeden önce bu elkitabını dikkatle okuyunuz.

MONTÖR İÇİN

### РУКОВОДСТВО ПО УСТАНОВКЕ

Для осторожного и правильного использования прибора необходимо тщательно ознакомиться с данным руководством по установке до выполнения установки кондиционера.

ДЛЯ УСТАНОВИТЕЛЯ

English

Deutsch

Français

Nederlands

Español

Italiano

Ελληνικά

Português

Dansk

Svenska

Türkçe

Русский

# Contents

1. Safety precautions.....	2	6. Drainage piping work.....	10
2. Installation diagram & parts.....	3	7. Electrical work.....	10
3. Installation location.....	4	8. Test run.....	14
4. Installing the outdoor unit.....	6	9. Special Functions.....	15
5. Installing the refrigerant piping.....	6		



**Note:** This symbol mark is for EU countries only.

This symbol mark is according to the directive 2002/96/EC Article 10 Information for users and Annex IV.

Your MITSUBISHI ELECTRIC product is designed and manufactured with high quality materials and components which can be recycled and reused. This symbol means that electrical and electronic equipment, at their end-of-life, should be disposed of separately from your household waste.

Please, dispose of this equipment at your local community waste collection/recycling centre.

In the European Union there are separate collection systems for used electrical and electronic product.

Please, help us to conserve the environment we live in!

## ⚠ Caution:

- Do not vent R410A into the Atmosphere.
- R410A is a Fluorinated Greenhouse gas, covered by the Kyoto Protocol, with a Global Warming Potential (GWP)=1975.

## 1. Safety precautions

- ▶ Before installing the unit, make sure you read all the "Safety precautions".
- ▶ Please report to or take consent by the supply authority before connection to the system.
- ▶ Equipment complying with IEC/EN 61000-3-12

## ⚠ Warning:

Describes precautions that must be observed to prevent danger of injury or death to the user.

## ⚠ Caution:

Describes precautions that must be observed to prevent damage to the unit.

## ⚠ Warning:

- The unit must not be installed by the user. Ask a dealer or an authorized technician to install the unit. If the unit is installed incorrectly, water leakage, electric shock, or fire may result.
- For installation work, follow the instructions in the Installation Manual and use tools and pipe components specifically made for use with R410A refrigerant. The R410A refrigerant in the HFC system is pressurized 1.6 times the pressure of usual refrigerants. If pipe components not designed for R410A refrigerant are used and the unit is not installed correctly, the pipes may burst and cause damage or injuries. In addition, water leakage, electric shock, or fire may result.
- The unit must be installed according to the instructions in order to minimize the risk of damage from earthquakes, typhoons, or strong winds. An incorrectly installed unit may fall down and cause damage or injuries.
- The unit must be securely installed on a structure that can sustain its weight. If the unit is mounted on an unstable structure, it may fall down and cause damage or injuries.
- If the air conditioner is installed in a small room, measures must be taken to prevent the refrigerant concentration in the room from exceeding the safety limit in the event of refrigerant leakage. Consult a dealer regarding the appropriate measures to prevent the allowable concentration from being exceeded. Should the refrigerant leak and cause the concentration limit to be exceeded, hazards due to lack of oxygen in the room may result.
- Ventilate the room if refrigerant leaks during operation. If refrigerant comes into contact with a flame, poisonous gases will be released.
- All electric work must be performed by a qualified technician according to local regulations and the instructions given in this manual. The units must be powered by dedicated power lines and the correct voltage and circuit breakers must be used. Power lines with insufficient capacity or incorrect electrical work may result in electric shock or fire.
- Be sure to connect the power supply cords and the connecting wires for the indoor units, outdoor units, and branch boxes directly to the units (no intermediate connections).  
Intermediate connections can lead to communication errors if water enters the cords or wires and causes insufficient insulation to ground or a poor electrical contact at the intermediate connection point.

After installation work has been completed, explain the "Safety Precautions," use, and maintenance of the unit to the customer according to the information in the Operation Manual and perform the test run to ensure normal operation. Both the Installation Manual and Operation Manual must be given to the user for keeping. These manuals must be passed on to subsequent users.

⚡ : Indicates a part which must be grounded.

## ⚠ Warning:

Carefully read the labels affixed to the main unit.

(If an intermediate connection is necessary, be sure to take measures to prevent water from entering the cords and wires.)

- Use C1220 copper phosphorus, for copper and copper alloy seamless pipes, to connect the refrigerant pipes. If the pipes are not connected correctly, the unit will not be properly grounded and electric shock may result.
- Use only specified cables for wiring. The connections must be made securely without tension on the terminals. If the cables are connected or installed incorrectly, overheating or fire may result.
- The terminal block cover panel of the outdoor unit must be firmly attached. If the cover panel is mounted incorrectly and dust and moisture enter the unit, electric shock or fire may result.
- When installing or relocating, or servicing the air conditioner, use only the specified refrigerant (R410A) to charge the refrigerant lines. Do not mix it with any other refrigerant and do not allow air to remain in the lines.  
If air is mixed with the refrigerant, then it can be the cause of abnormal high pressure in the refrigerant line, and may result in an explosion and other hazards.  
The use of any refrigerant other than that specified for the system will cause mechanical failure or system malfunction or unit breakdown. In the worst case, this could lead to a serious impediment to securing product safety.
- Use only accessories authorized by Mitsubishi Electric and ask a dealer or an authorized technician to install them. If accessories are incorrectly installed, water leakage, electric shock, or fire may result.
- Do not alter the unit. Consult a dealer for repairs. If alterations or repairs are not performed correctly, water leakage, electric shock, or fire may result.
- The user should never attempt to repair the unit or transfer it to another location. If the unit is installed incorrectly, water leakage, electric shock, or fire may result. If the air conditioner must be repaired or moved, ask a dealer or an authorized technician.
- After installation has been completed, check for refrigerant leaks. If refrigerant leaks into the room and comes into contact with the flame of a heater or portable cooking range, poisonous gases will be released.
- Refrigerant leakage may cause suffocation. Provide ventilation in accordance with EN378-1.

### 1.1. Before installation

#### ⚠ Caution:

- Do not use the unit in an unusual environment. If the air conditioner is installed in areas exposed to steam, volatile oil (including machine oil), or sulfuric gas, areas exposed to high salt content such as the seaside, or areas where the unit will be covered by snow, the performance can be significantly reduced and the internal parts can be damaged.
- Do not install the unit where combustible gases may leak, be produced, flow, or accumulate. If combustible gas accumulates around the unit, fire or explosion may result.
- The outdoor unit produces condensation during the heating operation. Make

sure to provide drainage around the outdoor unit if such condensation is likely to cause damage.

- When installing the unit in a hospital or communications office, be prepared for noise and electronic interference. Inverters, home appliances, high-frequency medical equipment, and radio communications equipment can cause the air conditioner to malfunction or breakdown. The air conditioner may also affect medical equipment, disturbing medical care, and communications equipment, harming the screen display quality.

### 1.2. Before installation (relocation)

#### ⚠ Caution:

- Be extremely careful when transporting the units. Two or more persons are needed to handle the unit, as it weighs 20 kg or more. Do not grasp the packaging bands. Wear protective gloves to remove the unit from the packaging and to move it, as you can injure your hands on the fins or other parts.
- Be sure to safely dispose of the packaging materials. Packaging materials, such as nails and other metal or wooden parts may cause stabs or other injuries.

- The base and attachments of the outdoor unit must be periodically checked for looseness, cracks or other damage. If such defects are left uncorrected, the unit may fall down and cause damage or injuries.
- Do not clean the air conditioner unit with water. Electric shock may result.
- Tighten all flare nuts to specification using a torque wrench. If tightened too much, the flare nut can break after an extended period and refrigerant can leak out.

# 1. Safety precautions

## 1.3. Before electric work

⚠ Caution:

- Be sure to install circuit breakers. If not installed, electric shock may result.

**IMPORTANT**

Make sure that the current leakage breaker is one compatible with higher harmonics.

Always use a current leakage breaker that is compatible with higher harmonics as this unit is equipped with an inverter.

The use of an inadequate breaker can cause the incorrect operation of inverter.

- For the power lines, use standard cables of sufficient capacity. Otherwise, a short circuit, overheating, or fire may result.

- When installing the power lines, do not apply tension to the cables. If the connections are loosened, the cables can snap or break and overheating or fire may result.
- Be sure to ground the unit. Do not connect the ground wire to gas or water pipes, lighting rods, or telephone grounding lines. If the unit is not properly grounded, electric shock may result.
- Use circuit breakers (ground fault interrupter, isolating switch (+B fuse), and molded case circuit breaker) with the specified capacity. If the circuit breaker capacity is larger than the specified capacity, breakdown or fire may result.

## 1.4. Before starting the test run

⚠ Caution:

- Turn on the main power switch more than 12 hours before starting operation. Starting operation just after turning on the power switch can severely damage the internal parts. Keep the main power switch turned on during the operation season.
- Before starting operation, check that all panels, guards and other protective parts are correctly installed. Rotating, hot, or high voltage parts can cause injuries.

- Do not touch any switch with wet hands. Electric shock may result.
- Do not touch the refrigerant pipes with bare hands during operation. The refrigerant pipes are hot or cold depending on the condition of the flowing refrigerant. If you touch the pipes, burns or frostbite may result.
- After stopping operation, be sure to wait at least five minutes before turning off the main power switch. Otherwise, water leakage or breakdown may result.

## 1.5. Using R410A refrigerant air conditioners

⚠ Caution:

- Use C1220 copper phosphorus, for copper and copper alloy seamless pipes, to connect the refrigerant pipes. Make sure the insides of the pipes are clean and do not contain any harmful contaminants such as sulfuric compounds, oxidants, debris, or dust. Use pipes with the specified thickness. (Refer to page 6) Note the following if reusing existing pipes that carried R22 refrigerant.

- Replace the existing flare nuts and flare the flared sections again.
- Do not use thin pipes. (Refer to page 6)
- Store the pipes to be used during installation indoors and keep both ends of the pipes sealed until just before brazing. (Leave elbow joints, etc. in their packaging.) If dust, debris, or moisture enters the refrigerant lines, oil deterioration or compressor breakdown may result.
- Use ester oil, ether oil, alkylbenzene oil (small amount) as the refrigeration oil applied to the flared sections. If mineral oil is mixed in the refrigeration oil, oil deterioration may result.

- Do not use refrigerant other than R410A refrigerant. If another refrigerant is used, the chlorine will cause the oil to deteriorate.
- Use the following tools specifically designed for use with R410A refrigerant. The following tools are necessary to use R410A refrigerant. Contact your nearest dealer for any questions.

Tools (for R410A)	
Gauge manifold	Flare tool
Charge hose	Size adjustment gauge
Gas leak detector	Vacuum pump adapter
Torque wrench	Electronic refrigerant charging scale

- Be sure to use the correct tools. If dust, debris, or moisture enters the refrigerant lines, refrigeration oil deterioration may result.
- Do not use a charging cylinder. If a charging cylinder is used, the composition of the refrigerant will change and the efficiency will be lowered.

# 2. Installation diagram & parts

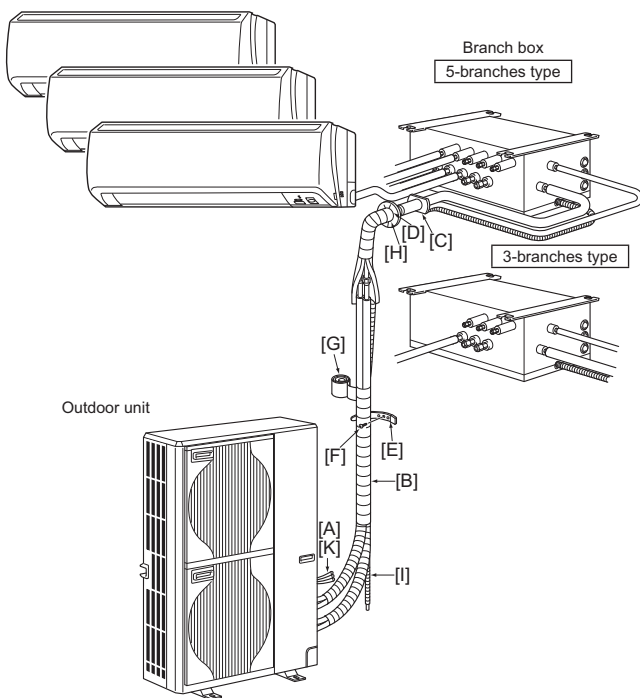

Fig. 2-1

## 2.1. Before installation (Fig. 2-1)

This installation manual is only for the outdoor unit installation. In installing the indoor units and branch box, refer to the installation manual attached to each unit.

Any structural alterations necessary for the installation must comply with the local building code requirements.

This diagram is intended to show the configuration of accessories. For actual installation, the outdoor unit is to be turned 180°.

Units should be installed by licensed contractor according to local code requirement.

**Note:**

The dimensions given along the arrows above are required to guarantee the air conditioner's performance. Install the unit in as wide a place as possible for later service or repairs.

**Parts to be locally procured**

[A]	Branch box/outdoor unit connecting wire (3-core, Refer to 7.3. External wiring procedure)	1
[B]	Extension pipe	1
[C]	Wall hole sleeve	1
[D]	Wall hole cover	1
[E]	Pipe fixing band (The quantity depends on the pipe length.)	2 to 7
[F]	Fixing screw for [E] 4 × 20 mm (The quantity depends on the pipe length.)	2 to 7
[G]	Piping tape	1
[H]	Putty	1
[I]	Drain hose (hard PVC pipe VP16)	1
[J]	Refrigeration oil	1
[K]	Power supply cord (2-core, Refer to 7.3. External wiring procedure)	1

### 3. Installation location

#### 3.1. Refrigerant pipe

Refer to 5.2. Pipe length and height difference.

#### 3.2. Choosing the outdoor unit installation location

- Avoid locations exposed to direct sunlight or other sources of heat.
- Select a location from which noise emitted by the unit will not inconvenience neighbors.
- Select a location permitting easy wiring and pipe access to the power source and indoor unit.
- Avoid locations where combustible gases may leak, be produced, flow, or accumulate.
- Note that water may drain from the unit during operation.
- Select a level location that can bear the weight and vibration of the unit.
- Avoid locations where the unit can be covered by snow. In areas where heavy snow fall is anticipated, special precautions such as raising the installation location or installing a hood on the air intake must be taken to prevent the snow from blocking the air intake or blowing directly against it. This can reduce the airflow and a malfunction may result.
- Avoid locations exposed to oil, steam, or sulfuric gas.
- Use the transportation handles of the outdoor unit to transport the unit. If the unit is carried from the bottom, hands or fingers may be pinched.

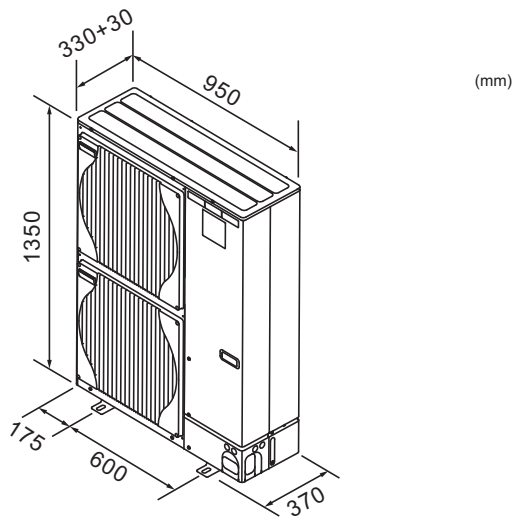

Fig. 3-1

#### 3.3. Outline dimensions (Outdoor unit) (Fig. 3-1)

##### Constraints on indoor unit installation

You should note that indoor units that can be connected to this outdoor unit are the following models.

- Indoor units with model numbers 15, 20, 22, 25, 35, 42, 50, 60, 71, 80, 100 can be connected. Refer to the table below for possible 2-8 room, indoor unit combinations.

##### Verification

The rated capacity should be determined by observing the table below. The unit's quantities are limited in 2 to 8 units. For the next step, make sure that the total rated capacity selected will stay in a range as shown below.

- MXZ-8B140 3.0~18.5kw
- MXZ-8B160 3.0~20.2kw

##### Example: MXZ-8B140

MSZ-60	=	6.0	}	Total rated capacity
	+			
SEZ-35	=	3.5		
	+			
SLZ-35	=	3.5		
	+			
SEZ-25	=	2.5	18.0 ≤ 18.5 kW	
	+			
SLZ-25	=	2.5		

Indoor unit type	15	20	22	25	35	42	50	60	71	80	100*1
Rated capacity (Cooling) (kW)	1.5	2.0	2.2	2.5	3.5	4.2	5.0	6.0	7.1	8.0	10.0

Combinations in which the total capacity of indoor units exceeds the capacity of the outdoor unit will reduce the cooling capacity of each indoor unit below their rated cooling capacity. Thus, combine indoor units with an outdoor unit within the outdoor unit's capacity, if possible.

\*1 When connecting the indoor unit with the model number 100, use the PAC-AK52BC branch box. Along with this, the PAC-AK52YP-E Y-shape connection pipe is required.

##### The capacity of outdoor unit

- MXZ-8B140 14.0kw
- MXZ-8B160 15.5kw

#### 3.4. Ventilation and service space

##### 3.4.1. Windy location installation

When installing the outdoor unit on a rooftop or other location unprotected from the wind, situate the air outlet of the unit so that it is not directly exposed to strong winds. Strong wind entering the air outlet may impede the normal airflow and a malfunction may result.

The following shows three examples of precautions against strong winds.

- ① Face the air outlet towards the nearest available wall about 50 cm away from the wall. (Fig. 3-2)
- ② Install an optional air guide if the unit is installed in a location where strong winds from a typhoon, etc. may directly enter the air outlet. (Fig. 3-3)
  - Ⓐ Air guide
- ③ Position the unit so that the air outlet blows perpendicularly to the seasonal wind direction, if possible. (Fig. 3-4)
  - Ⓑ Wind direction

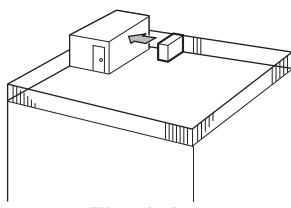

Fig. 3-2

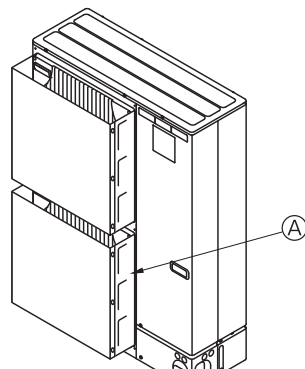

Fig. 3-3

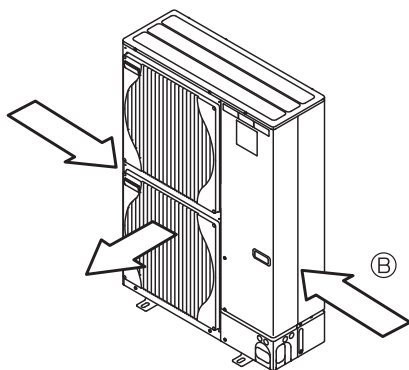

Fig. 3-4

### 3. Installation location

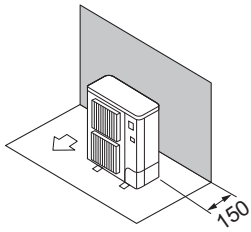

Fig. 3-5

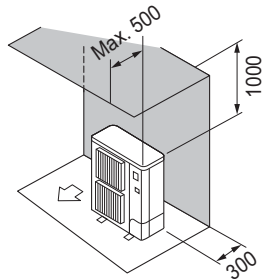

Fig. 3-6

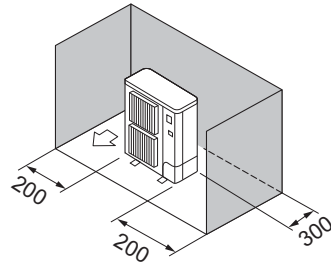

Fig. 3-7

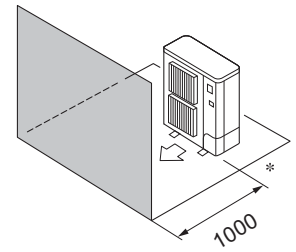

Fig. 3-8

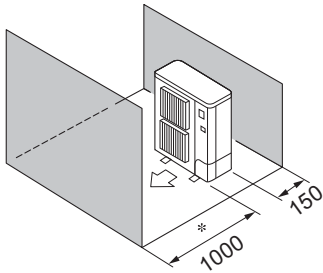

Fig. 3-9

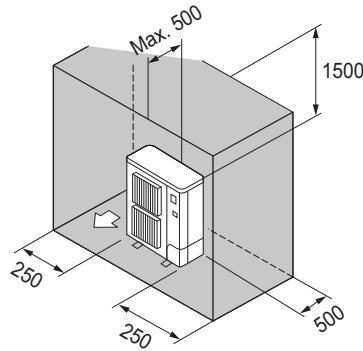

Fig. 3-10

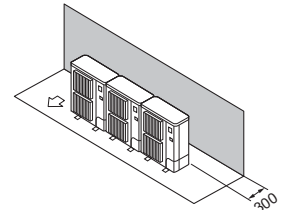

Fig. 3-11

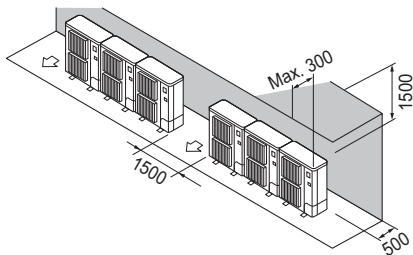

Fig. 3-12

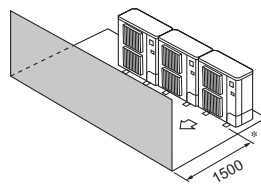

Fig. 3-13

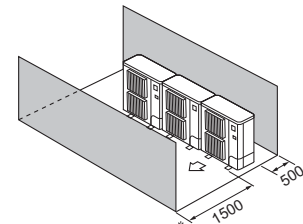

Fig. 3-14

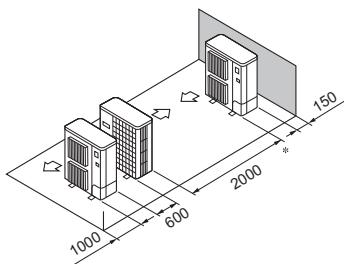

Fig. 3-15

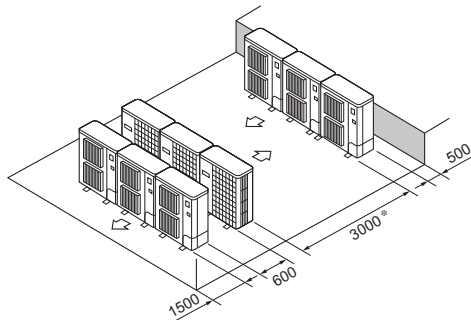

Fig. 3-16

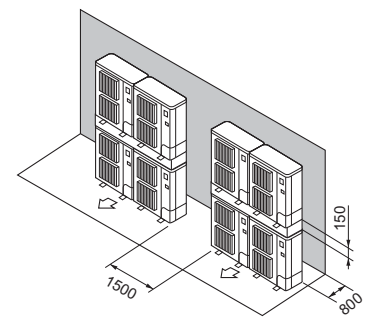

Fig. 3-17

#### 3.4.2. When installing a single outdoor unit

Minimum dimensions are as follows, except for Max., meaning Maximum dimensions, indicated.

Refer to the figures for each case.

- ① Obstacles at rear only (Fig. 3-5)
- ② Obstacles at rear and above only (Fig. 3-6)
- ③ Obstacles at rear and sides only (Fig. 3-7)
- ④ Obstacles at front only (Fig. 3-8)
- \* When using an optional air outlet guide, the clearance is 500 mm or more.
- ⑤ Obstacles at front and rear only (Fig. 3-9)
- \* When using an optional air outlet guide, the clearance is 500 mm or more.
- ⑥ Obstacles at rear, sides, and above only (Fig. 3-10)
- \* Do not install the optional air outlet guides for upward airflow.

#### 3.4.3. When installing multiple outdoor units

Leave 10 mm space or more between the units.

- ① Obstacles at rear only (Fig. 3-11)
- ② Obstacles at rear and above only (Fig. 3-12)
  - \* No more than three units must be installed side by side. In addition, leave space as shown.
  - \* Do not install the optional air outlet guides for upward airflow.
- ③ Obstacles at front only (Fig. 3-13)
  - \* When using an optional air outlet guide, the clearance is 1000 mm or more.
- ④ Obstacles at front and rear only (Fig. 3-14)
  - \* When using an optional air outlet guide, the clearance is 1000 mm or more.
- ⑤ Single parallel unit arrangement (Fig. 3-15)
  - \* When using an optional air outlet guide installed for upward airflow, the clearance is 1000 mm or more.
- ⑥ Multiple parallel unit arrangement (Fig. 3-16)
  - \* When using an optional air outlet guide installed for upward airflow, the clearance is 1500 mm or more.
- ⑦ Stacked unit arrangement (Fig. 3-17)
  - \* The units can be stacked up to two units high.
  - \* No more than two stacked units must be installed side by side. In addition, leave space as shown.



## 4. Installing the outdoor unit

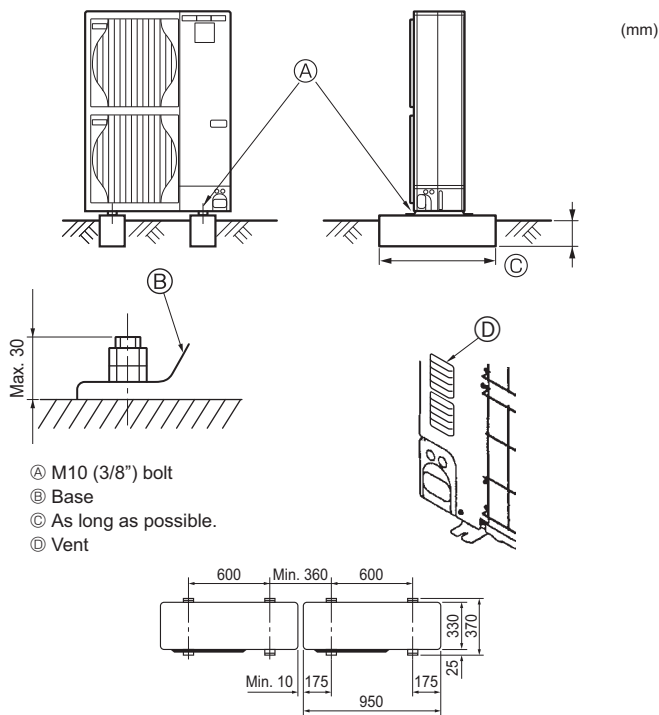

Fig. 4-1

- Be sure to install the unit in a sturdy, level surface to prevent rattling noises during operation. (Fig. 4-1)

<Foundation specifications>

Foundation bolt	M10 (3/8")
Thickness of concrete	120 mm
Length of bolt	70 mm
Weight-bearing capacity	320 kg

- Make sure that the length of the foundation bolt is within 30 mm of the bottom surface of the base.
- Secure the base of the unit firmly with four-M10 foundation bolts in sturdy locations.

### Installing the outdoor unit

- Do not block the vent. If the vent is blocked, operation will be hindered and breakdown may result.
- In addition to the unit base, use the installation holes on the back of the unit to attach wires, etc., if necessary to install the unit. Use self-tapping screws ( $\phi 5 \times 15$  mm or less) and install on site.

### Warning:

- The unit must be securely installed on a structure that can sustain its weight. If the unit is mounted on an unstable structure, it may fall down and cause damage or injuries.
- The unit must be installed according to the instructions in order to minimize the risk of damage from earthquakes, typhoons, or strong winds. An incorrectly installed unit may fall down and cause damage or injuries.

### Caution:

- Install the unit on a rigid structure to prevent excessive operation sound or vibration.

## 5. Installing the refrigerant piping

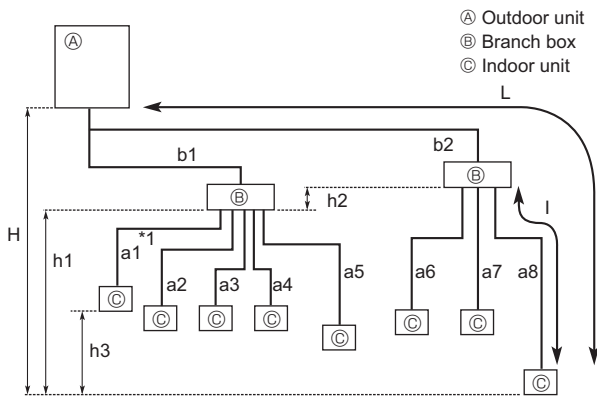

Fig. 5-1

\*1 Although two refrigerant pipes are used between the branch box and the Y-shape connection pipe when connecting the P100 indoor unit, calculate the piping lengths using only the length of one pipe. (Fig. 5-2)

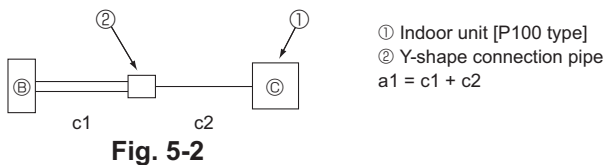

Fig. 5-2

### 5.1. Precautions for devices that use R410A refrigerant

- Refer to page 3 for precautions not included below on using air conditioners with R410A refrigerant.
- Use ester oil, ether oil, alkylbenzene oil (small amount) as the refrigeration oil applied to the flared sections.
- Use C1220 copper phosphorus, for copper and copper alloy seamless pipes, to connect the refrigerant pipes. Use refrigerant pipes with the thicknesses specified in the table to the below. Make sure the insides of the pipes are clean and do not contain any harmful contaminants such as sulfuric compounds, oxidants, debris, or dust.

### Warning:

When installing or relocating, or servicing the air conditioner, use only the specified refrigerant (R410A) to charge the refrigerant lines. Do not mix it with any other refrigerant and do not allow air to remain in the lines. If air is mixed with the refrigerant, then it can be the cause of abnormal high pressure in the refrigerant line, and may result in an explosion and other hazards. The use of any refrigerant other than that specified for the system will cause mechanical failure or system malfunction or unit breakdown. In the worst case, this could lead to a serious impediment to securing product safety.

$\phi 6.35, \phi 9.52, \phi 12.7$	Thickness 0.8 mm
$\phi 15.88$	Thickness 1.0 mm

- Do not use pipes thinner than those specified above.

### 5.2. Pipe length and height difference (Fig. 5-1)

#### Flared connections

- This unit has flared connections on each indoor unit and branch box and outdoor unit sides.
- Remove the valve cover of the outdoor unit, then connect the pipe.
- Refrigerant pipes are used to connect the branch box and outdoor unit.

Permissible length (one-way)	Total piping length	$b1+b2+a1+a2+a3+a4+a5+a6+a7+a8 \leq 115$ m
	Farthest piping length (L)	$b2+a8 \leq 70$ m ( $b2 \leq 55$ m, $a8 \leq 15$ m)
	Piping length between outdoor unit and branch boxes	$b1+b2 \leq 55$ m
	Farthest piping length after branch box (l)	$a8 \leq 15$ m
	Total piping length between branch boxes and indoor units	$a1+a2+a3+a4+a5+a6+a7+a8 \leq 60$ m
Permissible height difference (one-way)	In indoor/outdoor section (H)*2	$H \leq 30$ m (In case of outdoor unit is set higher than indoor unit) $H \leq 20$ m (In case of outdoor unit is set lower than indoor unit)
	In branch box/indoor unit section (h1)	$h1 + h2 \leq 15$ m
	In each branch unit (h2)	$h2 \leq 15$ m
	In each indoor unit (h3)	$h3 \leq 12$ m
Number of bends		$ b1+a1 ,  b1+a2 ,  b1+a3 ,  b1+a4 ,  b1+a5 ,  b2+a6 ,  b2+a7 ,  b2+a8  \leq 15$

\*2 Branch box should be placed within the level between the outdoor unit and indoor units.

## 5. Installing the refrigerant piping

### 5.3. Addition of refrigerant

- Additional charging is not necessary for this unit if the total pipe length (b1+b2+a1+a2+a3+a4+a5+a6+a7+a8) does not exceed 40 m.
- If the total pipe length exceeds 40 m, charge the unit with additional R410A refrigerant according to the permitted pipe lengths in the chart below.

\* When the unit is stopped, charge the unit with the additional refrigerant through the liquid stop valve after the pipe extensions and indoor unit have been vacuumized.

When the unit is operating, add refrigerant to the gas check valve using a safety charger. Do not add liquid refrigerant directly to the check valve.

**After charging the unit with refrigerant, note the added refrigerant amount on the service label (attached to the unit).**

Refer to the "1.5. Using R410A refrigerant air conditioners" for more information.

Table 1

Total piping length (b1+b2+a1+a2+a3+a4+a5+a6+a7+a8)	41 - 50 m	51 - 70 m	71 - 90 m	91 - 115 m
Additional refrigerant charging amount	0.6 kg	1.4 kg	2.2 kg	3.2 kg

If connecting an indoor unit with ø9.52 liquid pipes (model number 71 or more for M- and S-Series and model number 60 or more for P-Series), the additional refrigerant charging amount in Table 1 must be corrected (add the following ΔR value from the value given in Table 1).

Additional refrigerant charging correction amount

$$\Delta R = 0.01 \text{ [kg/m]} \times \text{ø9.52 branch pipe (liquid pipe) total length [m]}$$

Example) b1=20 m, b2=25 m

Indoor unit A	ø9.52 Liquid pipe	a1=12 m
Indoor unit B	ø6.35 Liquid pipe	a2=11 m
Indoor unit C	ø6.35 Liquid pipe	a6=14 m
Indoor unit D	ø9.52 Liquid pipe	a7=13 m

Total piping length : b1+b2+a1+a2+a6+a7=95 m

→ According to Table 1, the additional refrigerant charging amount is 3.2 kg.

Because indoor units with ø9.52 liquid pipes are connected (indoor units A and D in this example), the additional refrigerant charging amount must be corrected.

Additional refrigerant charging correction amount

$$\Delta R = 0.01 \text{ [kg/m]} \times \text{ø9.52 branch pipe (liquid pipe) total length (a1+a7)}$$

$$= 0.01 \times (12+13)$$

$$= 0.25 \text{ kg}$$

Therefore, the additional refrigerant charging amount is 3.2 kg + 0.25 kg = 3.45 kg.

\* Although two ø6.35 liquid pipes are used between the branch box and the Y-shape connection pipe when connecting the P100 indoor unit, calculate the additional refrigerant charging amount assuming only one ø9.52 liquid pipe is used.

#### ■ In case of using 1-branch box

Flare connection employed. (No. brazing)

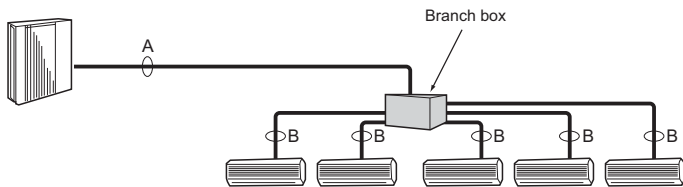

#### ■ In case of using 2-branch boxes

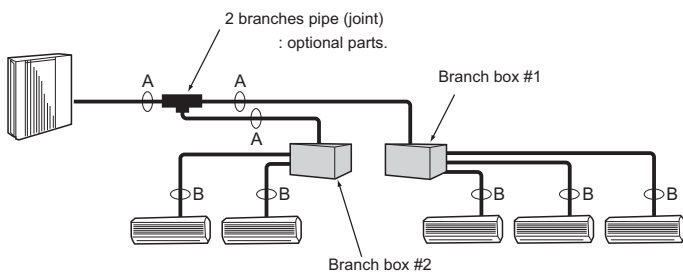

Fig. 5-3

(1) Valve size for outdoor unit

For liquid	ø9.52 mm
For gas	ø15.88 mm

(2) Valve size for branch box

UNIT	Pipe Type	Valve Size
A UNIT	Liquid pipe	ø6.35 mm
	Gas pipe	ø9.52 mm
B UNIT	Liquid pipe	ø6.35 mm
	Gas pipe	ø9.52 mm
C UNIT	Liquid pipe	ø6.35 mm
	Gas pipe	ø9.52 mm
D UNIT	Liquid pipe	ø6.35 mm
	Gas pipe	ø9.52 mm
E UNIT	Liquid pipe	ø6.35 mm
	Gas pipe	ø12.7 mm

\* 3-branch type : only A, B, C unit

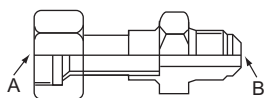

Fig. 5-4

Conversion formula

1/4 F	ø6.35
3/8 F	ø9.52
1/2 F	ø12.7
5/8 F	ø15.88
3/4 F	ø19.05

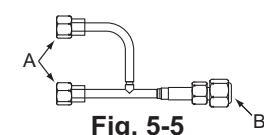

Fig. 5-5

### 5.4. Selecting pipe size (Fig. 5-3)

	A	B
Liquid (mm)	ø9.52	The piping connection size differs according to the type and capacity of indoor units. Match the piping connection size of branch box with indoor unit. If the piping connection size of branch box does not match the piping connection size of indoor unit, use optional different-diameter (deformed) joints to the branch box side. (Connect deformed joint directly to the branch box side.)
Gas (mm)	ø15.88	

#### Different-diameter joint (optional parts) (Fig. 5-4)

Model name	Connected pipes diameter		Diameter A	Diameter B
	mm		mm	mm
MAC-A454JP	ø9.52 →	ø12.7	ø9.52	ø12.7
MAC-A455JP	ø12.7 →	ø9.52	ø12.7	ø9.52
MAC-A456JP	ø12.7 →	ø15.88	ø12.7	ø15.88
PAC-493PI	ø6.35 →	ø9.52	ø6.35	ø9.52
PAC-SG76RJ-E	ø9.52 →	ø15.88	ø9.52	ø15.88

#### Y-shape connection pipe for 100 type indoor unit (optional parts) (Fig. 5-5)

Model name	Connected pipe diameter		Diameter A	Diameter B
	mm		mm	mm
PAC-AK52YP-E	Liquid	ø6.35 → ø9.52	ø6.35	ø9.52
	Gas	ø9.52 → ø15.88	ø9.52	ø15.88

#### ■ Installation procedure (Y-shape connection pipe)

Refer to the installation manuals of PAC-AK52YP-E.

#### Piping preparation

① Table below shows the specifications of pipes commercially available.

Outside diameter	Insulation thickness		Insulation material
	mm	mm	
6.35		8	Heat resisting foam plastic 0.045 specific gravity
9.52		8	
12.7		8	
15.88		8	

② Ensure that the 2 refrigerant pipes are insulated to prevent condensation.

③ Refrigerant pipe bending radius must be 100 mm or more.

#### ⚠ Caution:

Be sure to use the insulation of specified thickness. Excessive thickness may cause incorrect installation of the indoor unit and branch box, and lack of thickness may cause dew drip.

2-branch pipe (Joint) : Optional parts (According to the connection method, you can choose the favorite one.)

Model name	Connection method
MSDD-50AR-E	flare
MSDD-50BR-E	brazing

#### ■ Installation procedure (2 branches pipe (Joint))

Refer to the installation manuals of MSDD-50AR-E and MSDD-50BR-E.

## 5. Installing the refrigerant piping

### Refrigerant collection when relocating the indoor and outdoor units (pump down)

- ① Connect a gauge manifold valve (pressure gauge included) to the service port near the gas stop valve of the outdoor unit so that the refrigerant pressure can be measured.
- ② Turn on the power supply (circuit breaker).
- ③ Close the liquid stop valve, and then perform the test run for cooling operation (SW4-1: ON and SW4-2: OFF).
  - \* Be sure to wait at least 3 minutes after turning on the power supply before setting SW4-1 and SW4-2. If the DIP switches are set before 3 minutes has elapsed, the test run may not start.
- ④ Fully close the gas stop valve when the pressure reading on the gauge drops to 0.05 - 0.00 MPa\* (approximately 0.5 - 0.0 kgf/cm<sup>2</sup>).
  - \* If too much refrigerant has been added to the air conditioner system, the pressure may not drop to 0.5 kgf/cm<sup>2</sup>. If this occurs, use a refrigerant collecting device to collect all of the refrigerant in the system, and then recharge the system with the correct amount of refrigerant after the indoor and outdoor units have been relocated.
- ⑤ Stop the air conditioner operation (SW4-1: OFF and SW4-2: OFF).
- ⑥ Turn off the power supply (circuit breaker).

### 5.5. Connecting pipes (Fig. 5-6)

- When commercially available copper pipes are used, wrap liquid and gas pipes with commercially available insulation materials (heat-resistant to 100 °C or more, thickness of 12 mm or more).
- The indoor parts of the drain pipe should be wrapped with polyethylene foam insulation materials (specific gravity of 0.03, thickness of 9 mm or more).
- Apply thin layer of refrigerant oil to pipe and joint seating surface before tightening flare nut. ①
- Use two wrenches to tighten piping connections. ②
- Use leak detector or soapy water to check for gas leaks after connections are completed.
- Apply refrigerating machine oil over the entire flare seat surface. ③
- Use the flare nuts as follows. ④

#### ■ Pipe size (Outdoor unit-Branch box)

Pipe size (ømm)	Liquid	ø9.52
	Gas	ø15.88

The lineup of a connectable indoor unit depends on a district/areas/country.

#### ■ Pipe size (Branch box-Indoor unit) \*Case of M series or S series Indoor unit

Indoor unit type	(kW)	15	20	22	25	35	42	50	60	71	80
Pipe size (ømm)	Liquid	ø6.35	ø6.35	ø6.35	ø6.35	ø6.35	ø6.35	ø6.35	ø6.35	ø9.52	ø9.52
	Gas	ø9.52	ø9.52	ø9.52	ø9.52	ø9.52	ø9.52	ø12.7	ø15.88 *	ø15.88	ø15.88

\* When using 60 type indoor unit of MEXZ series, use the flare nut in the indoor unit accessory for the gas side connecting of indoor unit. Do not use the flare nut (gas side) attached to the indoor unit. If it is used, a gas leakage or even a pipe extraction may occur.

#### ■ Pipe size (Branch box-Indoor unit) \*Case of P series indoor unit

Indoor unit type	(kW)	*1 35	*1 50	60	71	*2 100
Pipe size (ømm)	Liquid	ø6.35	ø6.35	ø9.52	ø9.52	ø9.52
	Gas	ø12.7	ø12.7	ø15.88	ø15.88	ø15.88

\*1 When using 35, 50 type indoor unit of P series, use the flare nut attached to the indoor unit. Do not use the flare nut in the indoor unit accessory. If it is used, a gas leakage or even a pipe extraction may occur.

\*2 For details about connecting the pipes for the P100 indoor unit, refer to the installation manual of the Y-shape connection pipe (PAC-AK52YP-E).

- When bending the pipes, be careful not to break them. Bend radii of 100 mm to 150 mm are sufficient.
- Make sure the pipes do not contact the compressor. Abnormal noise or vibration may result.

- ① Pipes must be connected starting from the indoor unit. Flare nuts must be tightened with a torque wrench.
- ② Flare the liquid pipes and gas pipes and apply a thin layer of refrigeration oil (Applied on site).
- When usual pipe sealing is used, refer to Table 2 for flaring of R410A refrigerant pipes. The size adjustment gauge can be used to confirm A measurements.

#### ⚠ Caution:

- Be sure to wrap insulation around the piping. Direct contact with the bare piping may result in burns or frostbite.

Table 2 (Fig. 5-7)

Copper pipe O.D. (mm)	A (mm)	
	Flare tool for R410A	Flare tool for R22-R407C
	Clutch type	
ø6.35 (1/4")	0 - 0.5	1.0 - 1.5
ø9.52 (3/8")	0 - 0.5	1.0 - 1.5
ø12.7 (1/2")	0 - 0.5	1.0 - 1.5
ø15.88 (5/8")	0 - 0.5	1.0 - 1.5

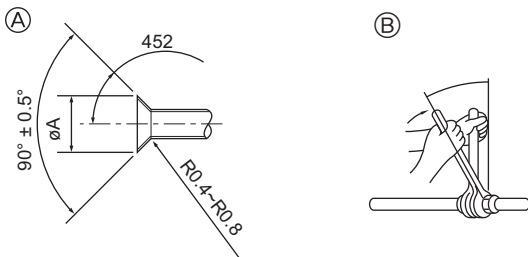

- ① Flare cutting dimensions  
② Flare nut tightening torque

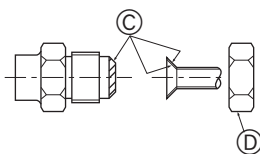

Fig. 5-6

① (Fig. 5-6)

Copper pipe O.D. (mm)	Flare dimensions øA dimensions (mm)
ø6.35	8.7 - 9.1
ø9.52	12.8 - 13.2
ø12.7	16.2 - 16.6
ø15.88	19.3 - 19.7

② (Fig. 5-6)

Copper pipe O.D. (mm)	Flare nut O.D. (mm)	Tightening torque (N·m)*
ø6.35	17	14 - 18
ø6.35	22	34 - 42
ø9.52	22	34 - 42
ø9.52	26	49 - 61
ø12.7	26	49 - 61
ø12.7	29	68 - 82
ø15.88	29	68 - 82
ø15.88	36	100 - 120

\* 1 N·m ≒ 10 kgf·cm

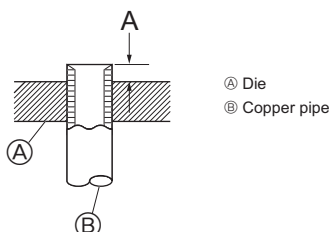

Fig. 5-7



## 5. Installing the refrigerant piping

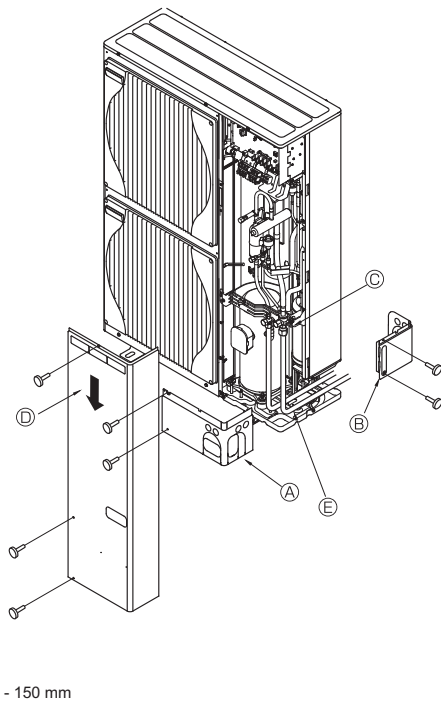

Fig. 5-8

### 5.6. Refrigerant piping (Fig. 5-8)

Remove the service panel ④ (three screws) and the front piping cover ① (two screws) and rear piping cover ② (two screws).

Refrigerant pipes are protectively wrapped

- The pipes can be protectively wrapped up to a diameter of  $\phi 90$  before or after connecting the pipes. Cut out the knockout in the pipe cover following the groove and wrap the pipes.

Pipe inlet gap

- Use putty or sealant to seal the pipe inlet around the pipes so that no gaps remain.

(If the gaps are not closed, noise may be emitted or water and dust will enter the unit and breakdown may result.)

### 5.7. Caution for piping connection/valve operation

- Conduct piping connection and valve operation accurately by following the figure below.

- Apply sealer along the insulator to prevent water entering the insulator covering the refrigerant pipe joints.

- After evacuation and refrigerant charge, ensure that the handle is fully open. If operating with the valve closed, abnormal pressure will be imparted to the high- or low-pressure side of the refrigerant circuit, giving damage to the compressor, etc.

- Determine the amount of additional refrigerant charge (refer "5.3. Addition of refrigerant"), and charge refrigerant additionally through the service port after completing piping connection work.

- After completing work, tighten the service port (12 - 15 N·m) and cap (20 - 25 N·m) securely to prevent gas leak.

\*1 N·m  $\approx$  10 kgf·cm

#### Method of completely opening the stop valve

The stop valve opening method varies according to the outdoor unit model. Use the appropriate method to open the stop valves.

(1) Type A (Fig. 5-9)

- ① Remove the cap, then turn one-quarter rotation counter-clockwise with a flat-bladed screwdriver to complete open.

- ② Check that the valves are fully open, then return the cap to its original state and tighten it down.

(2) Type B (Fig. 5-9)

- ① Remove the cap, pull the handle toward you and rotate 1/4 turn in a counterclockwise direction to open.

- ② Make sure that the stop valve is open completely, push in the handle and rotate the cap back to its original position.

(3) Type C (Fig. 5-10)

- ① Remove the cap and turn the valve rod counterclockwise as far as it will go with the use of a 4 mm hexagonal wrench. Stop turning when it hits the stopper.

- ② Make sure that the stop valve is open completely and rotate the cap back to its original position.

- |                     |  |
|---------------------|--|
| ① Valve             | ④ Completely open                                |
| ② Unit side         | ⑤ (On-side installation) Refrigerant piping side |
| ③ Service port      | ⑥ Direction the refrigerant flows in             |
| ⑦ Handle            | ⑦ Wrench hole                                    |
| ⑧ Cap               | ⑧ Completely closed                              |
| ⑨ Completely closed | ⑨ Operation section                              |

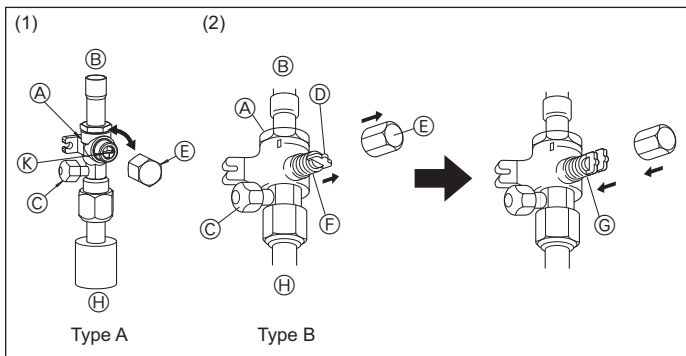

Fig. 5-9

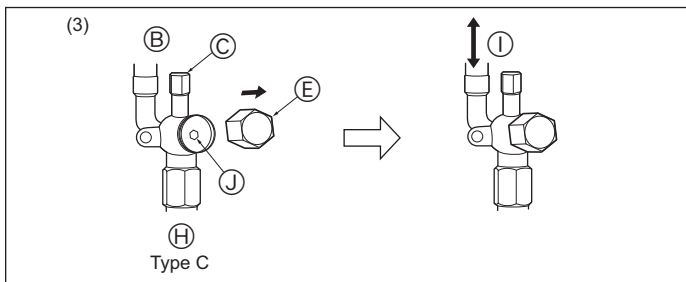

Fig. 5-10

### 5.8. Airtight test and evacuation

① **Airtight test (Fig. 5-11)**

Airtight test should be made by pressurizing nitrogen gas. For the test method, refer to the following figure.

- (1) Connecting the testing tool. Make a test with the stop valve closed. Be also sure to pressurize both liquid or high-pressure pipe and gas or low pressure pipe.

- (2) Do not add pressure to the specified pressure all at once; add pressure little by little.

- ① Pressurize to 0.5 MPa (5 kgf/cm<sup>2</sup>G), wait five minutes, and make sure the pressure does not decrease.

- ② Pressurize to 1.5 MPa (15 kgf/cm<sup>2</sup>G), wait five minutes, and make sure the pressure does not decrease.

- ③ Pressurize to 4.15 MPa (41.5 kgf/cm<sup>2</sup>G) and measure the surrounding temperature and refrigerant pressure.

- (3) If the specified pressure holds for about one day and does not decrease, the pipes have passed the test and there are no leaks.

- If the surrounding temperature changes by 1 °C, the pressure will change by about 0.01 MPa (0.1 kgf/cm<sup>2</sup>G). Make the necessary corrections.

- (4) If the pressure decreases in steps (2) or (3), there is a gas leak. Look for the source of the gas leak.

- |                   |                                     |
|-------------------|-------------------------------------|
| ① Nitrogen gas    | ④ Stop valve                        |
| ② System analyzer | ⑤ Liquid pipe or high-pressure pipe |
| ③ Lo-knob         | ⑥ Gas pipe or low-pressure pipe     |
| ⑦ Hi-knob         | ⑦ Service port                      |
| ⑧ To branch box   |                                     |
| ⑨ Outdoor unit    |                                     |

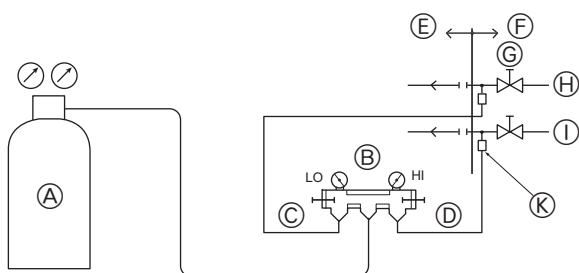

Fig. 5-11

## 5. Installing the refrigerant piping

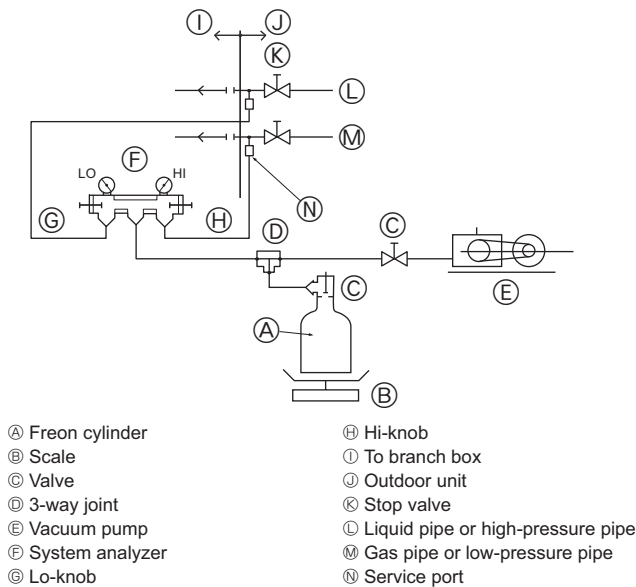

Fig. 5-12

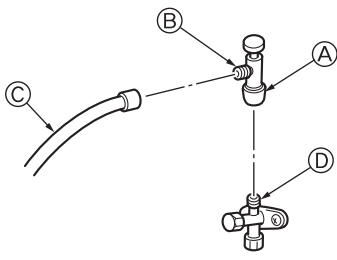

Fig. 5-13

- \* The figure to the left is an example only. The stop valve shape, service port position, etc., may vary according to the model.
- \* Turn section ① only. (Do not further tighten sections ① and ② together.)

### ② Evacuation (Fig. 5-12)

Evacuation should be made from the service port provided on the outdoor unit's stop valve to the vacuum pump commonly used for both liquid or high-pressure pipe and gas or low-pressure pipe. (Make evacuation from both liquid or high-pressure pipe and gas or low-pressure pipe with the stop valve closed.)

Remember: Never carry out air purge by refrigerant.

### ⚠ Warning:

**When installing or moving a unit to another place, do not mix anything other than specified refrigerant into the refrigeration cycle. If air is mixed, the refrigeration cycle may obtain abnormally high pressure, resulting in a burst pipe.**

\* A high-precision gravimeter measurable up to 0.1 kg should be used. If you are unable to prepare such a high-precision gravimeter, you may use a charging cylinder.

### Note:

- Use a gauge manifold, changing hose, and other parts for the refrigerant indicated on the unit.
- Use a gravimeter. (One that can measure down to 0.1 kg)

### Precautions when using the charge valve (Fig. 5-13)

Do not tighten the service port too much when installing it, otherwise, the valve core could be deformed and become loose, causing a gas leak.

After positioning section ① in the desired direction, turn section ② only and tighten it.

Do not further tighten sections ① and ② together after tightening section ②.

## 6. Drainage piping work

### Outdoor unit drainage pipe connection

When drain piping is necessary, use the drain socket or the drain pan (option).

Drain socket	PAC-SG61DS-E
Drain pan	PAC-SG64DP-E

## 7. Electrical work

### [1] Basic systems

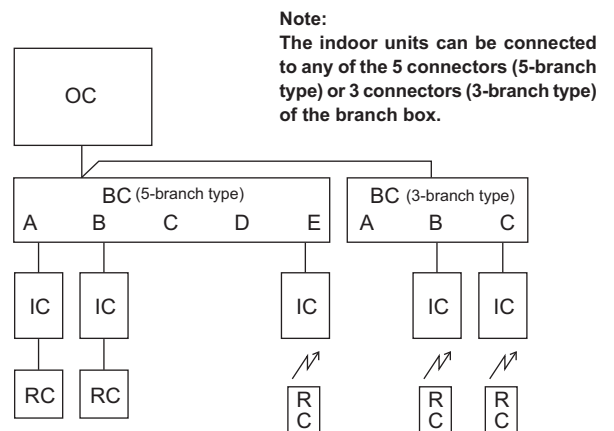
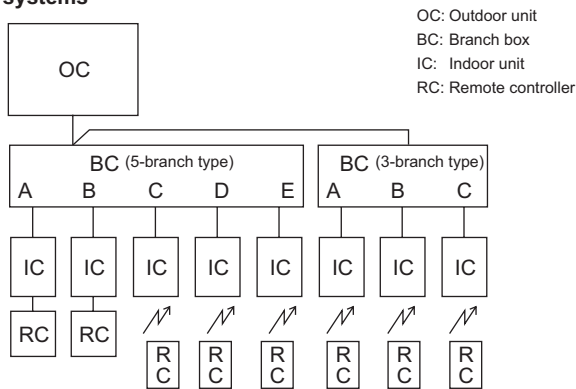

\* For details about connecting the wires for the P100 indoor unit, refer to the installation manual of the Branch box (PAC-AK52BC).

# 7. Electrical work

## [2] Standard systems

2-1. Only 3-branch type

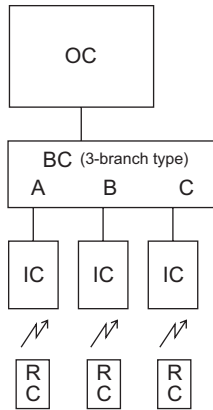

2-2. Only 5-branch type

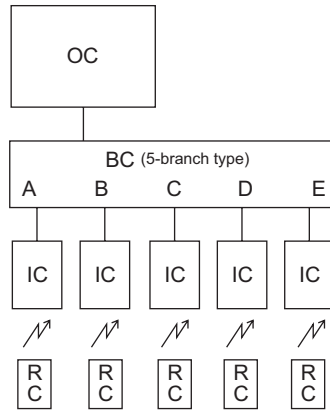

2-3. 2-branch boxes (3-branch type)

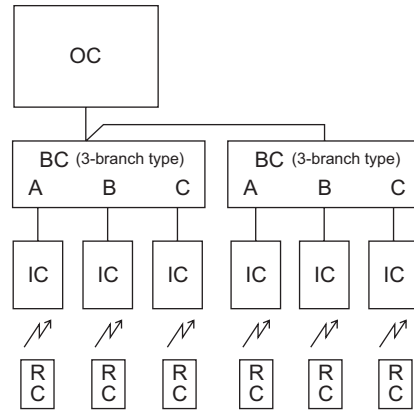

2-4. 2 branch boxes (5-branch type, maximum 8 indoor units)

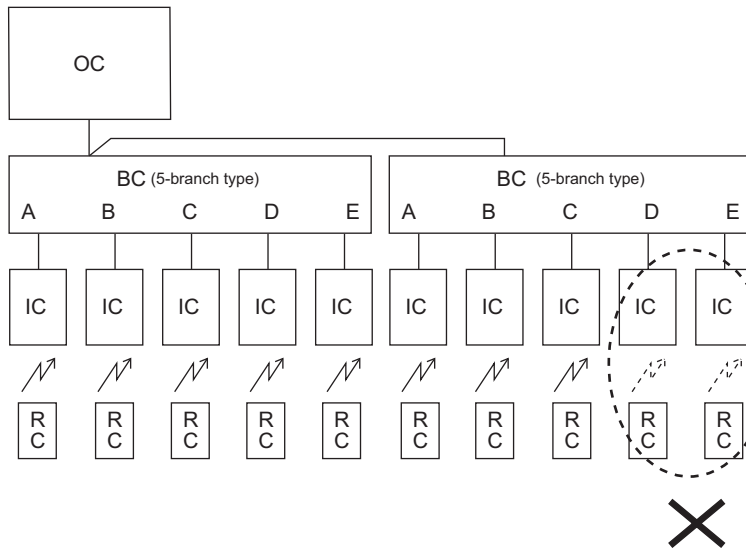

1. Up to 2 branch boxes can be connected to a single outdoor unit.
2. Up to 8 indoor units can be connected to the system.

## [3] Incorrect systems

3-1. Group operation by single remote controller

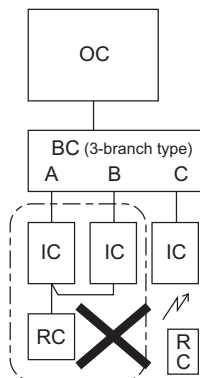

3-2. Group operation between different refrigerant systems

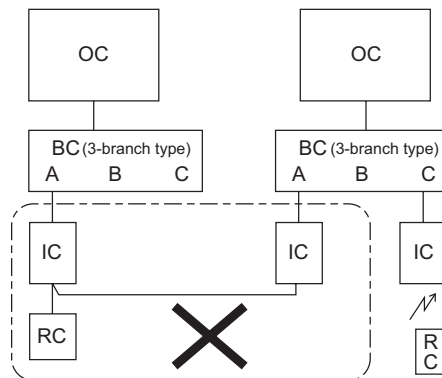

3-3. Connection of M-NET adapter to outdoor unit

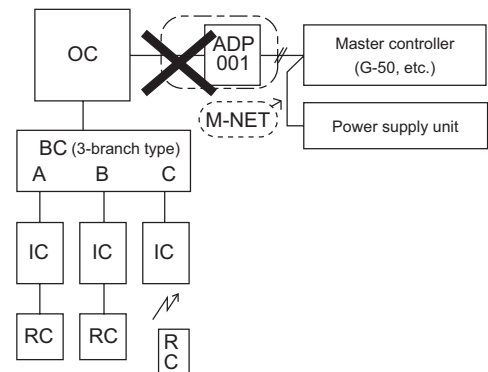

3-1. Plural indoor units cannot be operated by a single remote controller.

3-2. Different refrigerant systems cannot be connected together.

3-3. A M-NET adapter cannot be connected to an outdoor unit.

## 7. Electrical work

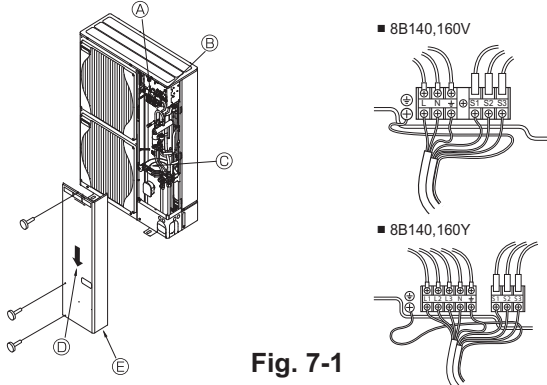

Fig. 7-1

### 7.1. Outdoor unit (Fig. 7-1)

- ① Remove the service panel.
- ② Wire the cables referring to the Fig. 7-1.
  - A Earth terminal
  - B Terminal block
  - C Clamp
  - D Service panel
  - E Wire the cables so that they do not contact the center of the service panel or the gas valve.

### 7.2. Branch box/outdoor wire connection and outdoor power supply cord connection

#### ⚠ Warning:

- Be sure to attach the terminal block covers/panel of the outdoor unit securely. If it is not attached correctly, it could result in a fire or an electric shock due to dust, water, etc.
- Be sure to connect the power supply cords and the connecting wires for the indoor units, outdoor units, and branch boxes directly to the units (no intermediate connections).  
Intermediate connections can lead to communication errors if water enters the cords or wires and causes insufficient insulation to ground or a poor electrical contact at the intermediate connection point.  
(If an intermediate connection is necessary, be sure to take measures to prevent water from entering the cords and wires.)

#### ⚠ Caution:

- Be careful not to make mis-wiring.
- Firmly tighten the terminal screws to prevent them from loosening.
- After tightening, pull the wires lightly to confirm that they not move.
- If the connecting wire is incorrectly connected to the terminal block, the unit does not operate normally.
- Be sure to install N-line. Without N-line, it could cause damage to the unit.

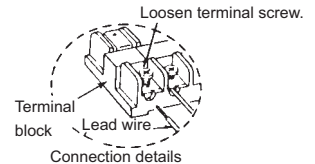

- Connect wire from the branch box correctly to the terminal block.
- For future servicing, give extra length to connecting wire.

### 7.3. External wiring procedure (Fig. 7-2)

The power supply work is needed only to the outdoor unit. The power supply to the branch box or indoor unit is conducted through wiring. Therefore, the power supply work can be carried out at just one spot of the outdoor unit. It will contribute to simplify the work and save costs.

#### Ⓒ Power supply

Model	Power supply
140-160V	~ /N 220/ 230/ 240V 50Hz , ~ /N 220V 60Hz
140-160Y	3N~ 380/ 400/ 415V 50Hz

Max. Permissive System Impedance 0.22(Ω)

#### Note:

- ① Power supply input: Outdoor unit only.  
Connect the lines (C), (D) in accordance with the terminal block names to ensure correct polarity.

Model	Wire diameter				Breaker *1	
	(A) Main power line	(B) Earth line	(C) Signal line	(D) Signal line	Interrupting current	Performance characteristic
140-160V	6.0 mm <sup>2</sup>	6.0 mm <sup>2</sup>	1.5 mm <sup>2</sup> *2	1.5 mm <sup>2</sup>	40 A	40A, 30 mA for 0.1 sec. or less
140-160Y	1.5 mm <sup>2</sup>	1.5 mm <sup>2</sup>	1.5 mm <sup>2</sup> *2	1.5 mm <sup>2</sup>	25 A	25A, 30 mA for 0.1 sec. or less

When using twisted wire for the wiring, the use of round terminal is required.

\*1. A breaker with at least 3 mm contact separation in each pole shall be provided. Use earth leakage breaker (NV).

\*2. Max. 45 m ("Outdoor unit - Branch box #1" plus "Branch box #1 - Branch box #2").  
If 2.5 mm<sup>2</sup> used, Max. 55 m.

- Notes:
1. Wiring size must comply with the applicable local and national code.
  2. Power supply cords and indoor unit/branch box/outdoor unit connecting cords shall not be lighter than polychloroprene sheathed flexible cord. (Design 60245 IEC 57)
  3. Install an earth line longer than power cables.

#### IMPORTANT

Make sure that the current leakage breaker is one compatible with higher harmonics.  
Always use a current leakage breaker that is compatible with higher harmonics as this unit is equipped with an inverter.  
The use of an inadequate breaker can cause the incorrect operation of inverter.

## 7. Electrical work

<Example> (In case of 2-branch boxes)

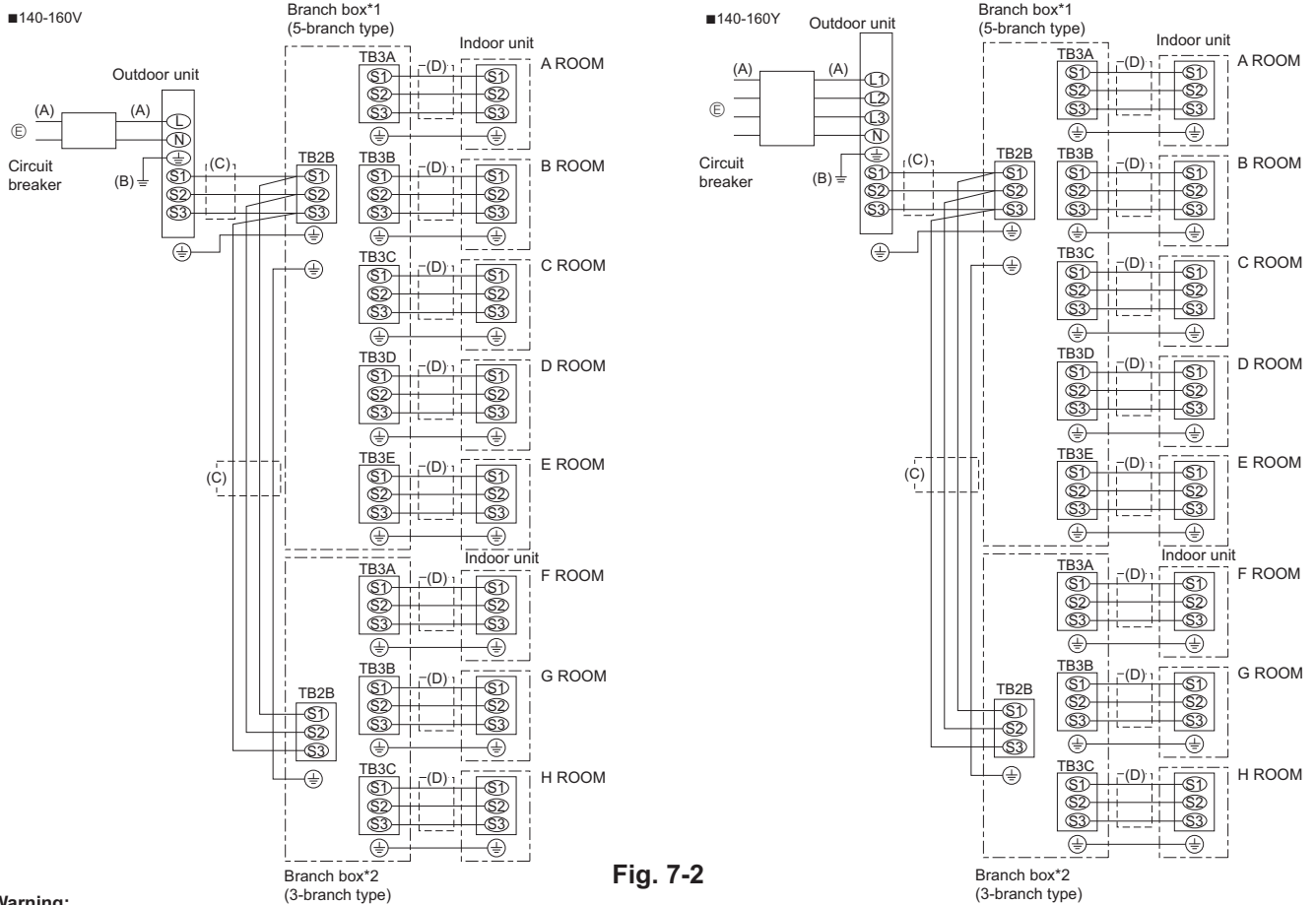
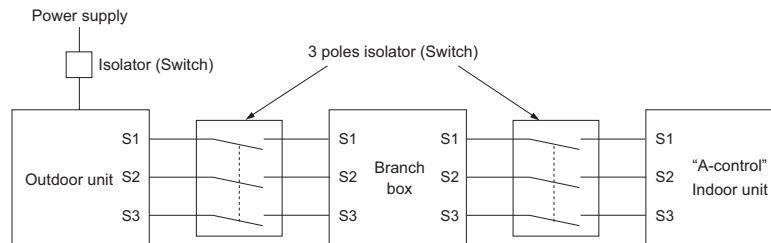

Fig. 7-2

**Warning:**

In case of A-control wiring, there is high voltage potential on the S3 terminal caused by electrical circuit design that has no electrical insulation between power line and communication signal line. Therefore, please turn off the main power supply when servicing. And do not touch the S1, S2, S3 terminals when the power is energized. If isolator should be used between outdoor unit and branch box/indoor unit and branch box, please use 3-poles type.



**Caution:**

After using the isolator, be sure to turn off and on the main power supply to reset the system. Otherwise, the outdoor unit may not be able to detect the branch box(es) or indoor units.

**WIRING SPECIFICATIONS  
(OUTDOOR-BRANCH BOX CONNECTING CABLE)**

Cross section of cable	Wire size (mm <sup>2</sup> )	Number of wires	Polarity	L (m)*6
Round	2.5	3	Clockwise : S1-S2-S3 * Pay attention to stripe of yellow and green	(50) *2
Flat	2.5	3	Not applicable (Because centre wire has no cover finish)	Not applicable *5
Flat	1.5	4	From left to right : S1-Open-S2-S3	(45) *3
Round	2.5	4	Clockwise : S1-S2-S3-Open *Connect S1 and S3 to the opposite angl	(55) *4

\*1 : Power supply cords of appliances shall not be lighter than design 60245 IEC or 227 IEC.

\*2 : In case that cable with stripe of yellow and green is available.

\*3 : In case of regular polarity connection (S1-S2-S3), wire size is 1.5 mm<sup>2</sup>.

\*4 : In case of regular polarity connection (S1-S2-S3).

\*5 : In the flat cables are connected as this picture, they can be used up to 55 m.

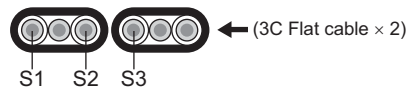

\*6 : Mentioned cable length is just a reference value.

It may be different depending on the condition of installation, Humidity or materials, etc.

Be sure to connect the outdoor-branch box/indoor-branch box connecting cables directly to the units (no intermediate connections). Intermediate connections can lead to communication errors if water enters the cables and causes insufficient insulation to ground or a poor electrical contact at the intermediate connection point.  
(If an intermediate connection is necessary, be sure to take measures to prevent water from entering the cables.)



## 8. Test run

### 8.1. Before test run

- ▶ After completing installation and the wiring and piping of the indoor and outdoor units, check for refrigerant leakage, looseness in the power supply or control wiring, wrong polarity, and no disconnection of one phase in the supply.
- ▶ Use a 500-volt M-ohm tester to check that the resistance between the power supply terminals and ground is at least 1 MΩ.
- ▶ Do not carry out this test on the control wiring (low voltage circuit) terminals.

**⚠ Warning:**

Do not use the air conditioner if the insulation resistance is less than 1 MΩ.

#### Insulation resistance

After installation or after the power source to the unit has been cut for an extended period, the insulation resistance will drop below 1 MΩ due to refrigerant accumulating in the compressor. This is not a malfunction. Perform the following procedures.

1. Remove the wires from the compressor and measure the insulation resistance of the compressor.
2. If the insulation resistance is below 1 MΩ, the compressor is faulty or the resistance dropped due the accumulation of refrigerant in the compressor.

3. After connecting the wires to the compressor, the compressor will start to warm up after power is supplied. After supplying power for the times indicated below, measure the insulation resistance again.
  - The insulation resistance drops due to accumulation of refrigerant in the compressor. The resistance will rise above 1 MΩ after the compressor is warmed up for two to three hours.  
(The time necessary to warm up the compressor varies according to atmospheric conditions and refrigerant accumulation.)
  - To operate the compressor with refrigerant accumulated in the compressor, the compressor must be warmed up at least 12 hours to prevent breakdown.
4. If the insulation resistance rises above 1 MΩ, the compressor is not faulty.

**⚠ Caution:**

- **The compressor will not operate unless the power supply phase connection is correct.**

- **Turn on the power at least 12 hours before starting operation.**

- Starting operation immediately after turning on the main power switch can result in severe damage to internal parts. Keep the power switch turned on during the operational season.

▶ **The followings must be checked as well.**

- The outdoor unit is not faulty. LED on the control board of the outdoor unit flash when the outdoor unit is faulty.
- Both the gas and liquid stop valves are completely open.

### 8.2. Test run

#### 8.2.1. Using remote controller

Refer to the indoor unit installation manual.

- Be sure to perform the test run for each indoor unit. Make sure each indoor unit operates properly following the installation manual attached to the unit.
- If you perform the test run for all indoor units at once, you cannot detect any erroneous connection, if any, of the refrigerant pipes and the connecting wires.
- \* The compressor operation is not available for 3 minutes at least after the power is supplied.
- The compressor can emit noise just after turn on the power supply or in case of low outside air temperature.

#### About the restart protective mechanism

Once the compressor stops, the restart preventive device operates so the compressor will not operate for 3 minutes to protect the air conditioner.

#### 8.2.2. Using SW4 in outdoor unit

**In case of the test run from outdoor unit, all indoor units operate. Therefore, you can not detect any erroneous connection of refrigerant pipes and the connecting wires. If it aims at detection of any erroneous connection, be sure to carry out the test run from remote controller with reference to "8.2.1. Using remote controller."**

SW4-1	ON	Cooling operation
SW4-2	OFF	
SW4-1	ON	Heating operation
SW4-2	ON	

\* After performing the test run, set SW4-1 to OFF.

- A few seconds after the compressor starts, a clanging noise may be heard from the inside of the outdoor unit. The noise is coming from the check valve due to the small difference in pressure in the pipes. The unit is not faulty.

**The test run operation mode cannot be changed by DIP switch SW4-2 during the test run. (To change the test run operation mode during the test run, stop the test run by DIP switch SW4-1. After changing the test run operation mode, resume the test run by switch SW4-1.)**

**When a test run is started by "Using SW4 in outdoor unit", even if it carries out stop instructions by remote controller, outdoor unit does not stop (a test run is not ended). In this case, please set SW4 in outdoor unit to off.**

#### Note:

Be sure to wait at least 3 minutes after turning on the power supply before setting SW4-1 and SW4-2. If the DIP switches are set before 3 minutes has elapsed, the test run may not start.

## 9. Special Functions

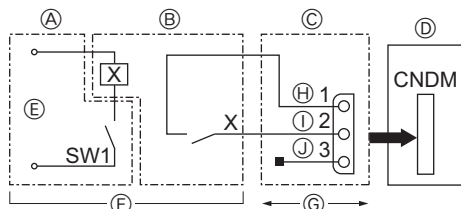

- Ⓐ Remote control panel
- Ⓑ Relay circuit
- Ⓒ External input adapter (PAC-SC36NA)
- Ⓓ Outdoor unit control board
- Ⓔ Relay power supply
- Ⓕ Procure locally
- Ⓖ Max. 10 m
- Ⓗ Orange
- Ⓘ Brown
- ⓷ Red

Fig. 9-1

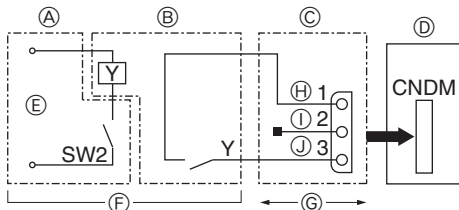

- Ⓐ Remote control panel
- Ⓑ Relay circuit
- Ⓒ External input adapter (PAC-SC36NA)
- Ⓓ Outdoor unit control board
- Ⓔ Relay power supply
- Ⓕ Procure locally
- Ⓖ Max. 10 m
- Ⓗ Orange
- Ⓘ Brown
- ⓷ Red

Fig. 9-2

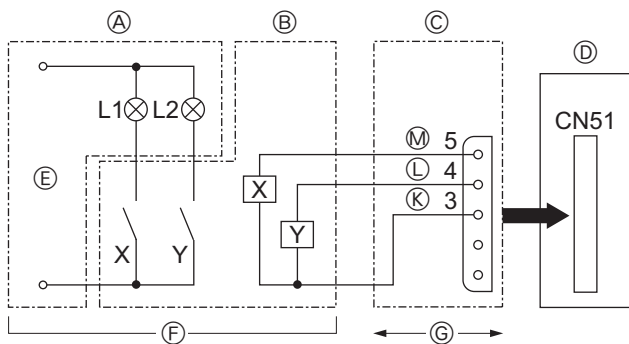

- L1: Error display lamp
- L2: Compressor operation lamp
- X, Y: Relay (Coil standard of 0.9W or less for DC 12V)
- X, Y: Relay (DC1mA)

Fig. 9-3

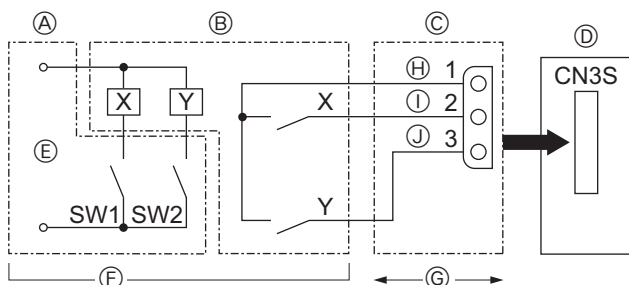

Fig. 9-4

### 9.1. Low noise mode (on-site modification) (Fig. 9-1)

By performing the following modification, operation noise of the outdoor unit can be reduced by about 3-4 dB.

The low noise mode will be activated when a commercially available timer or the contact input of an ON/OFF switch is added to the CNDM connector (option) on the control board of the outdoor unit.

- The capacity may be insufficient according to the outdoor temperature and conditions, etc.
- ① Complete the circuit as shown when using the external input adapter (PAC-SC36NA). (Option)

### 9.2. Demand function (on-site modification) (Fig. 9-2)

It is possible to reduce electricity consumption within a range from 0 to 100 percent by performing the following on-site installation.

The demand function can be enabled by adding a commercially available input contact point ON/OFF switch to the CNDM connector (the contact point demand input, sold separately).

- ① Incorporate the "Adaptor for external input (PAC-SC36NA)" into the circuit as shown in the diagram on the left.
- ② By switching SW7-1 on the control circuit board for the outdoor unit, the following power consumption restrictions (compared to rated power) can be set.

SW7-1	Power consumption when SW2 is on
OFF	0% (Forced compressor stop)
ON	50%

### 9.3. Error and compressor operation monitoring function (CN51)

- Ⓐ Remote control panel
- Ⓑ Relay circuit
- Ⓒ External output adapter (PAC-SA88HA-E)
- Ⓓ Outdoor unit control board
- Ⓔ Lamp power supply
- Ⓕ Procure locally
- Ⓖ Max. 10m
- Ⓚ Orange
- Ⓛ Yellow
- Ⓜ Green

### 9.4. Auto change over - Operation mode locking function by external signal (CN3S)

- Ⓐ Remote control panel
- Ⓑ Relay circuit
- Ⓒ External input adapter (PAC-SC36NA)
- Ⓓ Outdoor unit control board
- Ⓔ Relay power supply
- Ⓕ Procure locally
- Ⓖ Max. 10m
- Ⓗ Orange
- Ⓘ Brown
- ⓷ Red

	ON	OFF
SW1	Heating	Cooling
SW2	Validity of SW1	Invalidity of SW1

\* Any indoor unit that is operating in a mode different from the one specified by the external signal will enter the standby mode.

\* The setting becomes effective when the outdoor unit is under stop.

\* The operation mode specified for the test run has priority over the mode specified using this function.

---

Please be sure to put the contact address/telephone number on  
this manual before handing it to the customer.