

Revision D:

• MXZ-4E83VA- E3, ET3, ER2, MXZ-5E102VA-
E3, ET3, ER2 and MXZ-4E83VAHZ- E2, ER2
have been added.

OBH723 REVISED EDITION-C is void.

OUTDOOR UNIT

SERVICE MANUAL

**No. OBH723
REVISED EDITION-D**

Models

MXZ-3E54VA - E1, ET1, ER1
MXZ-3E68VA - E1, ET1, ER1
MXZ-4E72VA - E1, ET1, ER1
MXZ-4E83VA - E1, E2, E3, ET1, ET2, ET3, ER1, ER2
MXZ-5E102VA - E1, E2, E3, ET1, ET2, ET3, ER1, ER2
MXZ-2E53VAHZ - E1, ER1
MXZ-4E83VAHZ - E1, E2, ER1, ER2

Indoor unit service manual
 MSZ-EF•VE Series (OBH589)
 MSZ-SF•VA Series (OBH555)
 MSZ-SF•VE Series (OBH600)
 MSZ-FD•VA Series (OBH488)
 MSZ-FH•VE Series (OBH623)
 MSZ-GA•VA Series (OB378)
 MSZ-GE•VA Series (OBH515)
 MSZ-GF•VE Series (OBH634)
 MFZ-KA•VA Series (OB409)
 MFZ-KJ•VE Series (OBH666)
 MLZ-KA•VA Series (OBH483)
 SLZ-KA•VA Series (OC320)
 SEZ-KD•VA Series (HWE07110)
 PLA-RP•BA Series (OCH412)
 PCA-RP•KA Series (OCH454)
 PEAD-RP•JA Series (HWE08130)

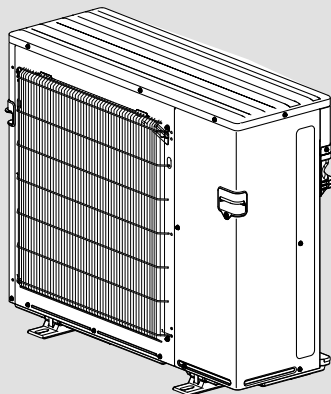

MXZ-4E83VA
 MXZ-5E102VA
 MXZ-2E53VAHZ

CONTENTS

1. TECHNICAL CHANGES	3
2. PART NAMES AND FUNCTIONS	4
3. SPECIFICATION	5
4. NOISE CRITERIA CURVES	12
5. OUTLINES AND DIMENSIONS	14
6. WIRING DIAGRAM	20
7. REFRIGERANT SYSTEM DIAGRAM	44
8. PERFORMANCE CURVES	52
9. ACTUATOR CONTROL	82
10. SERVICE FUNCTIONS	83
11. TROUBLESHOOTING	86
12. DISASSEMBLY INSTRUCTIONS	108

INDOOR UNITS COMBINATION SHEETS

PARTS CATALOG (OBB723)
NOTE:

RoHS compliant products have <G> mark on the spec name plate.

Use the specified refrigerant only

Never use any refrigerant other than that specified.

Doing so may cause a burst, an explosion, or fire when the unit is being used, serviced, or disposed of.

Correct refrigerant is specified in the manuals and on the spec labels provided with our products.

We will not be held responsible for mechanical failure, system malfunction, unit breakdown or accidents caused by failure to follow the instructions.

<Preparation before the repair service>

- Prepare the proper tools.
- Prepare the proper protectors.
- Provide adequate ventilation.
- After stopping the operation of the air conditioner, turn off the power-supply breaker and remove the power plug.
- Discharge the capacitor before the work involving the electric parts.

<Precautions during the repair service>

- Do not perform the work involving the electric parts with wet hands.
- Do not pour water into the electric parts.
- Do not touch the refrigerant.
- Do not touch the hot or cold areas in the refrigeration cycle.
- When the repair or the inspection of the circuit needs to be done without turning off the power, exercise great caution not to touch the live parts.

Revision A:

- MXZ-2E53VAHZ- [E1] and MXZ-4E83VAHZ- [E1] have been added.
- Values of air flow and fan speed for MXZ-5E102VA- [E1], [ET1] have been modified.

Revision B:

- MXZ-3E54VA- [E1], [ET1], MXZ-3E68VA- [E1], [ET1], and MXZ-4E72VA- [E1], [ET1] have been added.

Revision C:

- MXZ-3E54VA- [ER1], MXZ-3E68VA- [ER1], MXZ-4E72VA- [ER1], MXZ-4E83VA- [E2], [ET2], [ER1], MXZ-5E102VA- [E2], [ET2], [ER1], MXZ-2E53VAHZ- [ER1] and MXZ-4E83VAHZ- [ER1] have been added.

Revision D:

- MXZ-4E83VA- [E3], [ET3], [ER2], MXZ-5E102VA- [E3], [ET3], [ER2] and MXZ-4E83VAHZ- [E2], [ER2] have been added.

MXZ-4E83VA -[E1], [ET1], [ER1]

MXZ-5E102VA -[E1], [ET1], [ER1]

1. New model

MXZ-2E53VAHZ -[E1], [ER1]

1. New model

MXZ-4E83VAHZ -[E1], [ER1]

1. New model

MXZ-3E54VA -[E1], [ET1], [ER1]

MXZ-3E68VA -[E1], [ET1], [ER1]

MXZ-4E72VA -[E1], [ET1], [ER1]

1. New model

MXZ-4E83VA -[E1], [ET1] → **MXZ-4E83VA** -[E2], [ET2]

1. Fan motor has been changed.
2. Outdoor control P.C. board has been changed.

MXZ-5E102VA -[E1], [ET1] → **MXZ-5E102VA** -[E2], [ET2]

1. Fan motor has been changed.
2. Outdoor control P.C. board has been changed.

MXZ-4E83VA -[ER1] → **MXZ-4E83VA** -[ER2]

1. Outdoor control P.C. board has been changed.

MXZ-4E83VA -[E2], [ET2] → **MXZ-4E83VA** -[E3], [ET3]

1. Outdoor control P.C. board has been changed.

MXZ-5E102VA -[ER1] → **MXZ-5E102VA** -[ER2]

1. Outdoor control P.C. board has been changed.

MXZ-5E102VA -[E2], [ET2] → **MXZ-5E102VA** -[E3], [ET3]

1. Outdoor control P.C. board has been changed.

MXZ-4E83VAHZ -[E1], [ER1] → **MXZ-4E83VAHZ** -[E2], [ER2]

1. Outdoor control P.C. board has been changed.

2

PART NAMES AND FUNCTIONS

MXZ-3E54VA
MXZ-3E68VA
MXZ-4E72VA

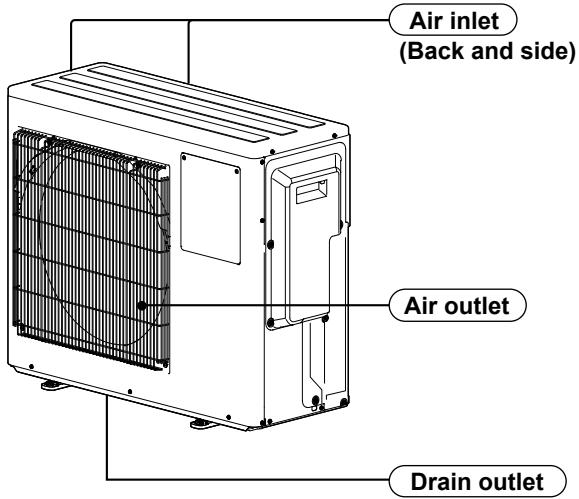

MXZ-4E83VA
MXZ-5E102VA
MXZ-2E53VAHZ

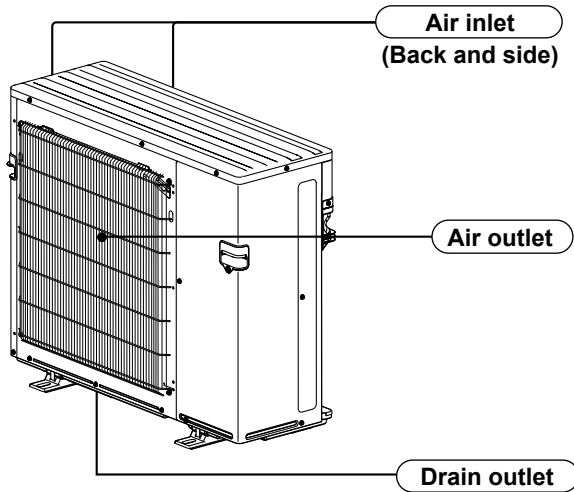

MXZ-4E83VAHZ

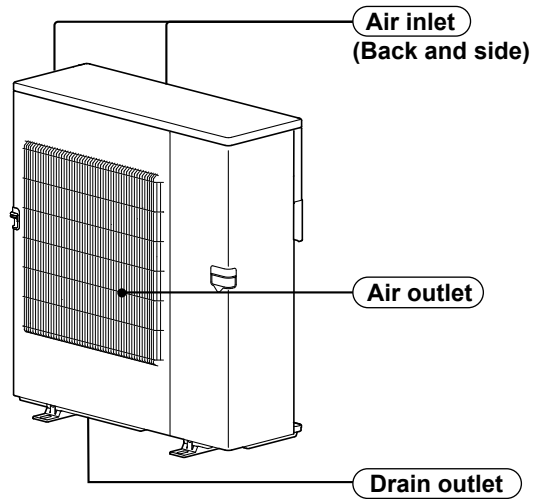

ACCESSORIES

Model	MXZ-3E54VA MXZ-3E68VA MXZ-4E72VA	MXZ-4E83VA MXZ-5E102VA
① Drain socket	1	1
② Drain cap	2	5

3

SPECIFICATION

Outdoor model			MXZ-3E54VA		
Outdoor unit power supply			Single phase 230 V, 50 Hz		
System	Indoor units number		2 to 3		
	Piping total length	m	Max. 50		
	Connecting pipe length	m	Max. 25		
	Height difference (Indoor ~ Outdoor)	m	Refer to 7 REFRIGERANT SYSTEM DIAGRAM.		
	Height difference (Indoor ~ Indoor)	m	Refer to 7 REFRIGERANT SYSTEM DIAGRAM.		
Function			Cooling	Heating	
Capacity Rated frequency (Min.-Max.) *2		kW	5.4 (2.9 - 6.8)	7.0 (2.6 - 9.0)	
Breaker capacity		A	25		
Electrical data	Power input (Total) *1, *2		W	1,350	1,590
	Running current (Total) *1, *2		A	5.9	7.0
	Power factor (Total) *1, *2		%	99	
	Starting current (Total) *1, *2		A	7.0	
Coeff icient of performance (C.O.P) (Total) *1, *2			4.00	4.40	
Compressor	Model		SNB130FGBH1T		
	Output	W	1,400		
	Current *1, *2		A	5.72	6.62
	Refrigeration oil (Model)		L	0.7 (NEO22)	
Fan motor	Model		SIC-71FW-F764-2		
	Current *1, *2		A	0.2	
Dimensions W x H x D		mm	840 x 710 x 330		
Weight		kg	58		
Special remarks	Air f ow (Rated)		m ³ /h	2,334	2,376
	Sound level (Rated)		dB(A)	50	53
	Fan speed (Rated)		rpm	650	660
	Refrigerant f lling capacity (R410A)		kg	2.7	

*1 Measured under rated operating frequency.

*2 When connected with indoor units below.

MSZ-EF18VE + MSZ-EF18VE + MSZ-EF18VE

NOTE: Test conditions are based on ISO 5151. (Refrigerant piping length (one way): 5 m)

COOLING INDOOR Dry-bulb temperature 27.0 °C Wet-bulb temperature 19.0 °C

OUTDOOR Dry-bulb temperature 35.0 °C Wet-bulb temperature 24.0 °C

HEATING INDOOR Dry-bulb temperature 20.0 °C

OUTDOOR Dry-bulb temperature 7.0 °C Wet-bulb temperature 6.0 °C



Outdoor model			MXZ-3E68VA	
Outdoor unit power supply			Single phase 230 V, 50 Hz	
System	Indoor units number		2 to 3	
	Piping total length	m	Max. 60	
	Connecting pipe length	m	Max. 25	
	Height difference (Indoor ~ Outdoor)	m	Refer to 7 REFRIGERANT SYSTEM DIAGRAM.	
	Height difference (Indoor ~ Indoor)	m	Refer to 7 REFRIGERANT SYSTEM DIAGRAM.	
Function			Cooling	Heating
Capacity Rated frequency (Min.-Max.) *2		kW	6.8 (2.9 - 8.4)	8.6 (2.6 - 10.6)
Breaker capacity		A	25	
Electrical data	Power input (Total) *1, *2	W	2,190	2,380
	Running current (Total) *1, *2	A	9.6	10.5
	Power factor (Total) *1, *2	%	99	
	Starting current (Total) *1, *2	A	10.5	
Coefficient of performance (C.O.P) (Total) *1, *2			3.11	3.61
Compressor	Model		SNB172FEGH1T	
	Output	W	1,800	
	Current *1, *2	A	9.22	10.12
	Refrigeration oil (Model)	L	0.7 (NEO22)	
Fan motor	Model		SIC-71FW-F764-2	
	Current *1, *2	A	0.2	
Dimensions W x H x D		mm	840 x 710 x 330	
Weight		kg	58	
Special remarks	Air flow (Rated)	m ³ /h	2,334	2,376
	Sound level (Rated)	dB(A)	50	53
	Fan speed (Rated)	rpm	650	660
	Refrigerant filling capacity (R410A)	kg	2.7	

*1 Measured under rated operating frequency.

*2 When connected with indoor units below.

MSZ-EF18VE + MSZ-EF25VE + MSZ-EF25VE

NOTE: Test conditions are based on ISO 5151. (Refrigerant piping length (one way): 5 m)

COOLING INDOOR Dry-bulb temperature 27.0 °C Wet-bulb temperature 19.0 °C

OUTDOOR Dry-bulb temperature 35.0 °C Wet-bulb temperature 24.0 °C

HEATING INDOOR Dry-bulb temperature 20.0 °C

OUTDOOR Dry-bulb temperature 7.0 °C Wet-bulb temperature 6.0 °C

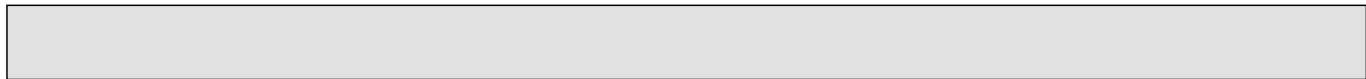

Outdoor model			MXZ-4E72VA	
Outdoor unit power supply			Single phase 230 V, 50 Hz	
System	Indoor units number		2 to 4	
	Piping total length	m	Max. 60	
	Connecting pipe length	m	Max. 25	
	Height difference (Indoor ~ Outdoor)	m	Refer to 7 REFRIGERANT SYSTEM DIAGRAM.	
	Height difference (Indoor ~ Indoor)	m	Refer to 7 REFRIGERANT SYSTEM DIAGRAM.	
Function			Cooling	Heating
Capacity Rated frequency (Min.-Max.) *2		kW	7.2 (3.7 - 8.8)	8.6 (3.4 - 10.7)
Breaker capacity		A	25	
Electrical data	Power input (Total) *1, *2	W	2,250	2,280
	Running current (Total) *1, *2	A	9.9	10.0
	Power factor (Total) *1, *2	%	99	
	Starting current (Total) *1, *2	A	10.0	
Coeff icient of performance (C.O.P) (Total) *1, *2			3.20	3.77
Compressor	Model		SNB172FEGH1T	
	Output	W	2,000	
	Current *1, *2	A	9.46	9.56
	Refrigeration oil (Model)	L	0.7 (NEO22)	
Fan motor	Model		SIC-71FW-F764-2	
	Current *1, *2	A	0.2	
Dimensions W x H x D		mm	840 x 710 x 330	
Weight		kg	59	
Special remarks	Air f ow (Rated)	m ³ /h	2,334	2,376
	Sound level (Rated)	dB(A)	50	53
	Fan speed (Rated)	rpm	650	660
	Refrigerant f lling capacity (R410A)	kg	2.7	

*1 Measured under rated operating frequency.

*2 When connected with indoor units below.

MSZ-EF18VE + MSZ-EF18VE + MSZ-EF18VE + MSZ-EF18VE

NOTE: Test conditions are based on ISO 5151. (Refrigerant piping length (one way): 5 m)

COOLING INDOOR Dry-bulb temperature 27.0 °C Wet-bulb temperature 19.0 °C

OUTDOOR Dry-bulb temperature 35.0 °C Wet-bulb temperature 24.0 °C

HEATING INDOOR Dry-bulb temperature 20.0 °C

OUTDOOR Dry-bulb temperature 7.0 °C Wet-bulb temperature 6.0 °C



Outdoor model			MXZ-4E83VA		
Outdoor unit power supply			Single phase 230 V, 50 Hz		
System	Indoor units number		2 to 4		
	Piping total length	m	Max. 70		
	Connecting pipe length	m	Max. 25		
	Height difference (Indoor ~ Outdoor)	m	Refer to 7 REFRIGERANT SYSTEM DIAGRAM.		
	Height difference (Indoor ~ Indoor)	m	Refer to 7 REFRIGERANT SYSTEM DIAGRAM.		
Function			Cooling	Heating	
Capacity Rated frequency (Min.-Max.) *2		kW	8.3 (3.7 - 9.2)	9.3 (3.4 - 11.6)	
Breaker capacity		A	25		
Electrical data	Power input (Total) *1, *2		W	2,440	2,000
	Running current (Total) *1, *2		A	10.7	8.8
	Power factor (Total) *1, *2		%	99	
	Starting current (Total) *1, *2		A	10.7	
Coefficient of performance (C.O.P) (Total) *1, *2			3.40	4.65	
Compressor	Model		SNB220FAGMC		
	Output	W	2,200		
	Current *1, *2	A	10.1	8.1	
	Refrigeration oil (Model)	L	0.7 (FV50S)		
Fan motor	Model		[E1], [ET1]: SIC-81FW-D888-9 [E2], [ET2], [ER1], [E3], [ET3], [ER2]: SIC-88FWJ-D888-1		
	Current *1, *2	A	0.3		
	Dimensions W x H x D	mm	950 x 796 x 330		
Weight		kg	[E1], [ET1]: 62 / [E2], [ET2], [ER1], [E3], [ET3], [ER2]: 63		
Special remarks	Air flow (Rated)		m ³ /h	3,336	3,336
	Sound level (Rated)		dB(A)	49	51
	Fan speed (Rated)		rpm	620	620
	Refrigerant filling capacity (R410A)		kg	2.99	

*1 Measured under rated operating frequency.

*2 When connected with below indoor units.

MSZ-EF18VE + MSZ-EF18VE + MSZ-EF22VE + MSZ-EF25VE

NOTE: Test conditions are based on ISO 5151. (Refrigerant piping length (one way): 5 m)

COOLING INDOOR Dry-bulb temperature 27.0°C Wet-bulb temperature 19.0°C

OUTDOOR Dry-bulb temperature 35.0°C Wet-bulb temperature 24.0°C

HEATING INDOOR Dry-bulb temperature 20.0°C

OUTDOOR Dry-bulb temperature 7.0°C Wet-bulb temperature 6.0°C



Outdoor model		MXZ-5E102VA	
Outdoor unit power supply		Single phase 230 V, 50 Hz	
System	Indoor units number	2 to 5	
	Piping total length	m	Max. 80
	Connecting pipe length	m	Max. 25
	Height difference (Indoor ~ Outdoor)	m	Refer to 7 REFRIGERANT SYSTEM DIAGRAM.
	Height difference (Indoor ~ Indoor)	m	Refer to 7 REFRIGERANT SYSTEM DIAGRAM.
Function		Cooling	Heating
Capacity Rated frequency (Min.-Max.) *2		kW	10.2 (3.9 - 11.0) 10.5 (4.1 - 14.0)
Breaker capacity		A	25
Electrical data	Power input (Total) *1, *2	W	3,150 2,340
	Running current (Total) *1, *2	A	13.8 10.3
	Power factor (Total) *1, *2	%	99
	Starting current (Total) *1, *2	A	13.8
Coeff icient of performance (C.O.P) (Total) *1, *2			3.24 4.49
Compressor	Model	SNB220FAGMC	
	Output	W	2,800
	Current *1, *2	A	13.0 9.4
	Refrigeration oil (Model)	L	0.7 (FV50S)
Fan motor	Model	[E1], [ET1]: SIC-81FW-D888-9 [E2], [ET2], [ER1], [E3], [ET3], [ER2]: SIC-88FWJ-D888-1	
	Current *1, *2	A	0.5
Dimensions W x H x D		mm	950 x 796 x 330
Weight		kg	[E1], [ET1]: 63 / [E2], [ET2], [ER1], [E3], [ET3], [ER2]: 64
Special remarks	Air f ow (Rated)	m ³ /h	[E1], [ET1]: 3,336 / [E2], [ET2], [ER1], [E3], [ET3], [ER2]: 3,906 4,080
	Sound level (Rated)	dB(A)	52 56
	Fan speed (Rated)	rpm	[E1], [ET1]: 620 / [E2], [ET2], [ER1], [E3], [ET3], [ER2]: 720 750
	Refrigerant f lling capacity (R410A)	kg	2.99

*1 Measured under rated operating frequency.

*2 When connected with below indoor units.

MSZ-EF18VE + MSZ-EF18VE + MSZ-EF22VE + MSZ-EF22VE + MSZ-EF22VE

NOTE: Test conditions are based on ISO 5151. (Refrigerant piping length (one way): 5 m)

COOLING INDOOR Dry-bulb temperature 27.0°C Wet-bulb temperature 19.0°C

OUTDOOR Dry-bulb temperature 35.0°C Wet-bulb temperature 24.0°C

HEATING INDOOR Dry-bulb temperature 20.0°C

OUTDOOR Dry-bulb temperature 7.0°C Wet-bulb temperature 6.0°C

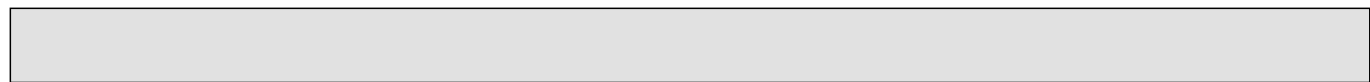

Outdoor model			MXZ-2E53VAHZ	
Outdoor unit power supply			Single phase 230 V, 50 Hz	
System	Indoor units number		2	
	Piping total length	m	Max. 30	
	Connecting pipe length	m	Max. 20	
	Height difference (Indoor ~ Outdoor)	m	Refer to 7 REFRIGERANT SYSTEM DIAGRAM.	
	Height difference (Indoor ~ Indoor)	m	Refer to 7 REFRIGERANT SYSTEM DIAGRAM.	
Function			Cooling	Heating
Capacity Rated frequency (Min.-Max.) *2		kW	5.3 (1.1 - 6.0)	6.4 (1.0 - 7.0)
Breaker capacity		A	16/25 *3	
Electrical data	Power input (Total) *1, *2		W	1,290
	Running current (Total) *1, *2		A	5.7
	Power factor (Total) *1, *2		%	98
	Starting current (Total) *1, *2		A	6.0
Coefficient of performance (C.O.P) (Total) *1, *2			4.11	4.71
Compressor	Model		SNB220FAGMC	
	Output	W	1,400	
	Current *1, *2	A	5.3	5.5
	Refrigeration oil (Model)	L	0.7 (FV50S)	
Fan motor	Model		E1: SIC-81FW-D888-9, SIC-88FWJ-D888-1 ER1: SIC-88FWJ-D888-1	
	Current *1, *2	A	0.3	
Dimensions W x H x D		mm	950 x 796 x 330	
Weight		kg	61	
Special remarks	Air flow (Rated)		m ³ /h	2,820
	Sound level (Rated)		dB(A)	45
	Fan speed (Rated)		rpm	520
	Refrigerant filling capacity (R410A)		kg	2.0

*1 Measured under rated operating frequency.

*2 When connected with below indoor units.

*3 When the amount of current exceeds the allowed value.

MSZ-EF18VE + MSZ-EF35VE

NOTE: Test conditions are based on ISO 5151. (Refrigerant piping length (one way): 5 m)

COOLING INDOOR Dry-bulb temperature 27.0°C Wet-bulb temperature 19.0°C

OUTDOOR Dry-bulb temperature 35.0°C Wet-bulb temperature 24.0°C

HEATING INDOOR Dry-bulb temperature 20.0°C

OUTDOOR Dry-bulb temperature 7.0°C Wet-bulb temperature 6.0°C



Outdoor model			MXZ-4E83VAHZ		
Outdoor unit power supply			Single phase 230 V, 50 Hz		
System	Indoor units number		2 to 4		
	Piping total length	m	Max. 70		
	Connecting pipe length	m	Max. 25		
	Height difference (Indoor ~ Outdoor)	m	Refer to 7 REFRIGERANT SYSTEM DIAGRAM.		
	Height difference (Indoor ~ Indoor)	m	Refer to 7 REFRIGERANT SYSTEM DIAGRAM.		
Function			Cooling	Heating	
Capacity Rated frequency (Min.-Max.) *2		kW	8.3 (3.5 - 9.2)	9.0 (3.5 - 11.6)	
Breaker capacity		A	25/30 *3		
Electrical data	Power input (Total) *1, *2		W	2,250	1,900
	Running current (Total) *1, *2		A	9.9	8.3
	Power factor (Total) *1, *2		%	99	
	Starting current (Total) *1, *2		A	9.9	
Coeffcient of performance (C.O.P) (Total) *1, *2			3.68	4.73	
Compressor	Model		MNB33FBTMC-L		
	Output	W	2,200		
	Current *1, *2	A	9.30	7.60	
	Refrigeration oil (Model)	L	1.10 (FV50S)		
Fan motor	Model		SIC-81FW-D888-9, SIC-88FWJ-D888-1		
	Current *1, *2	A	0.3		
Dimensions W x H x D		mm	950 x 1,048 x 330		
Weight		kg	87		
Special remarks	Air flow (Rated)	m ³ /h	3,780	4,620	
	Sound level (Rated)	dB(A)	53	57	
	Fan speed (Rated)	rpm	650	770	
	Refrigerant filling capacity (R410A)	kg	3.9		

*1 Measured under rated operating frequency.

*2 When connected with indoor units below.

*3 When the amount of current exceeds the allowed value.

MSZ-EF18VE + MSZ-EF18VE + MSZ-EF22VE + MSZ-EF25VE

NOTE: Test conditions are based on ISO 5151. (Refrigerant piping length (one way): 5 m)

COOLING INDOOR Dry-bulb temperature 27.0 °C Wet-bulb temperature 19.0 °C

OUTDOOR Dry-bulb temperature 35.0 °C Wet-bulb temperature 24.0 °C

HEATING INDOOR Dry-bulb temperature 20.0 °C

OUTDOOR Dry-bulb temperature 7.0 °C Wet-bulb temperature 6.0 °C

MXZ-3E54VA

FAN SPEED	FUNCTION	SPL(dB(A))	LINE
High	Cooling	50	●—●
High	Heating	53	○—○

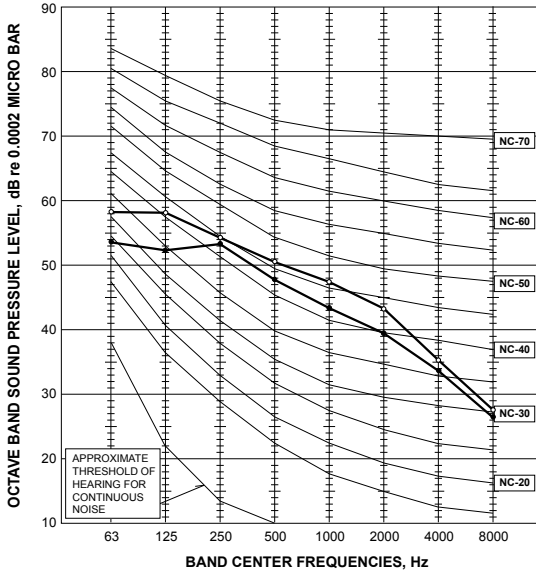

MXZ-3E68VA

FAN SPEED	FUNCTION	SPL(dB(A))	LINE
High	Cooling	50	●—●
High	Heating	53	○—○

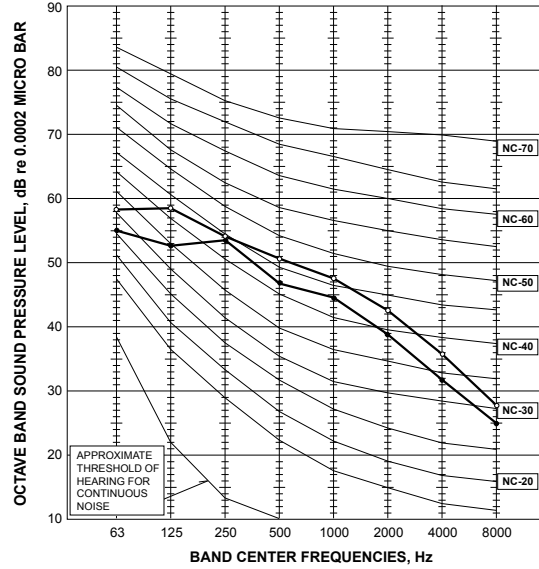

MXZ-4E72VA

FAN SPEED	FUNCTION	SPL(dB(A))	LINE
High	Cooling	50	●—●
High	Heating	53	○—○

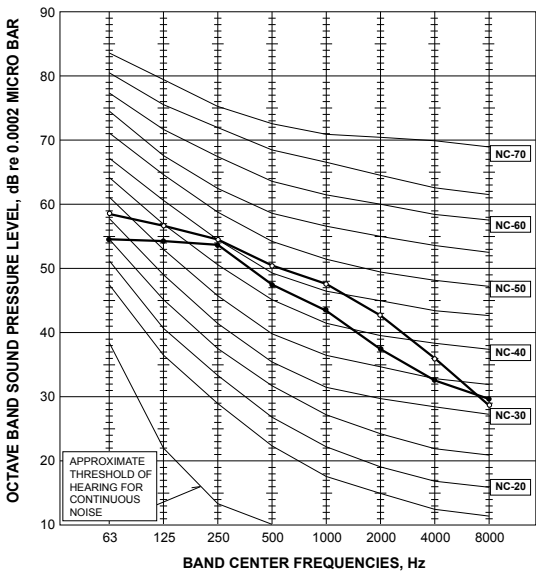

MXZ-4E83VA

FAN SPEED	FUNCTION	SPL(dB(A))	LINE
High	Cooling	49	●—●
High	Heating	51	○—○

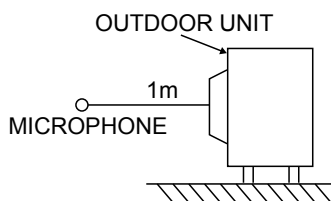
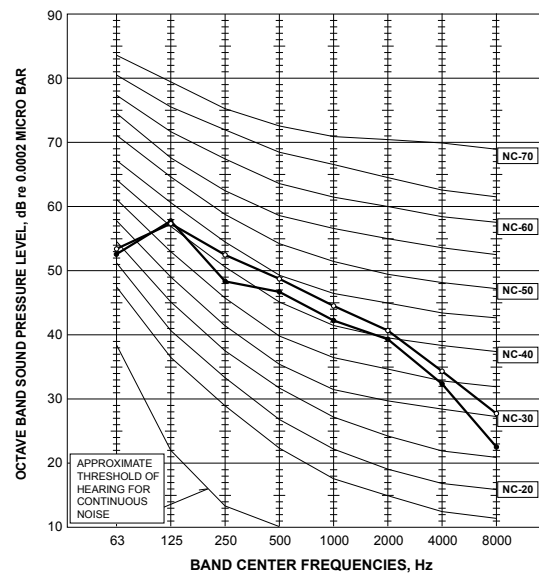

Test conditions

Cooling : Dry-bulb temperature 35.0°C Wet-bulb temperature 24.0°C
 Heating : Dry-bulb temperature 7.0°C Wet-bulb temperature 6.0°C

MXZ-5E102VA

FAN SPEED	FUNCTION	SPL(dB(A))	LINE
High	Cooling	52	●—●
High	Heating	56	○—○

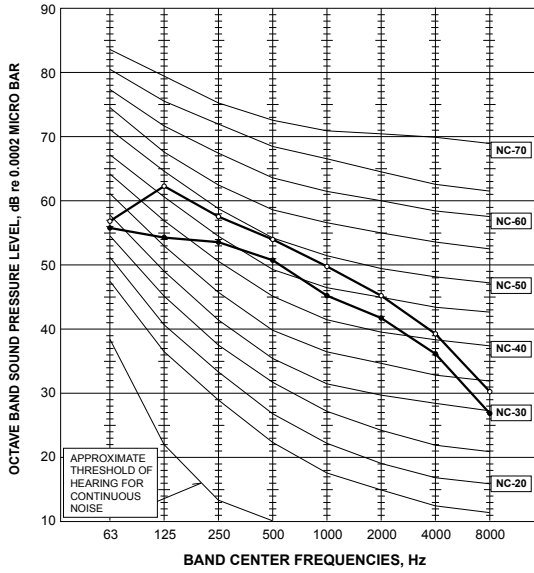

MXZ-2E53VAHZ

FAN SPEED	FUNCTION	SPL(dB(A))	LINE
High	Cooling	45	●—●
High	Heating	47	○—○

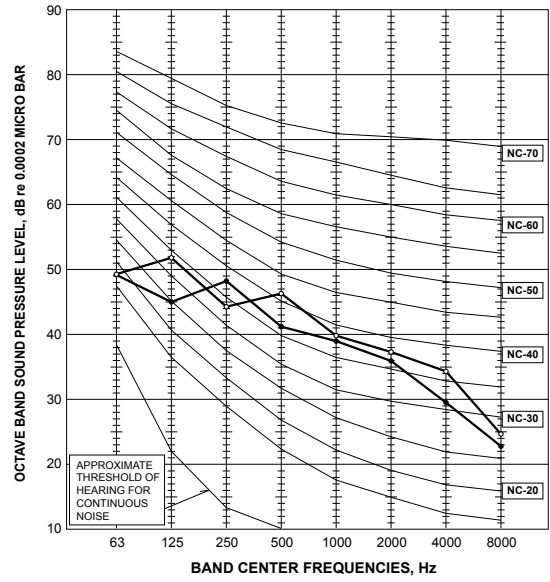

MXZ-4E83VAHZ

FAN SPEED	FUNCTION	SPL(dB(A))	LINE
High	Cooling	53	●—●
High	Heating	57	○—○

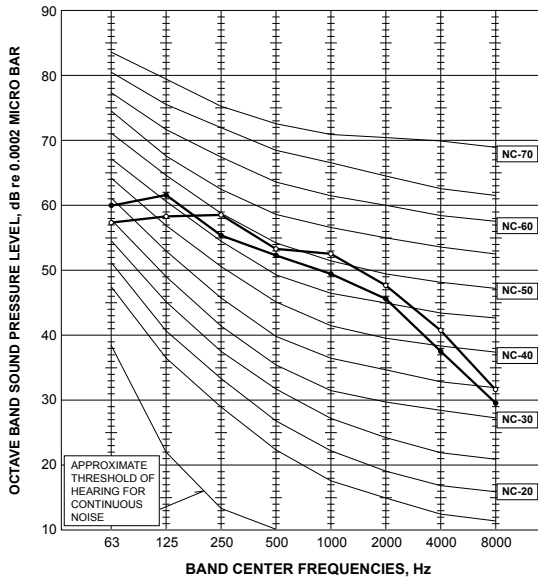

MXZ-3E54VA MXZ-3E68VA

Unit: mm

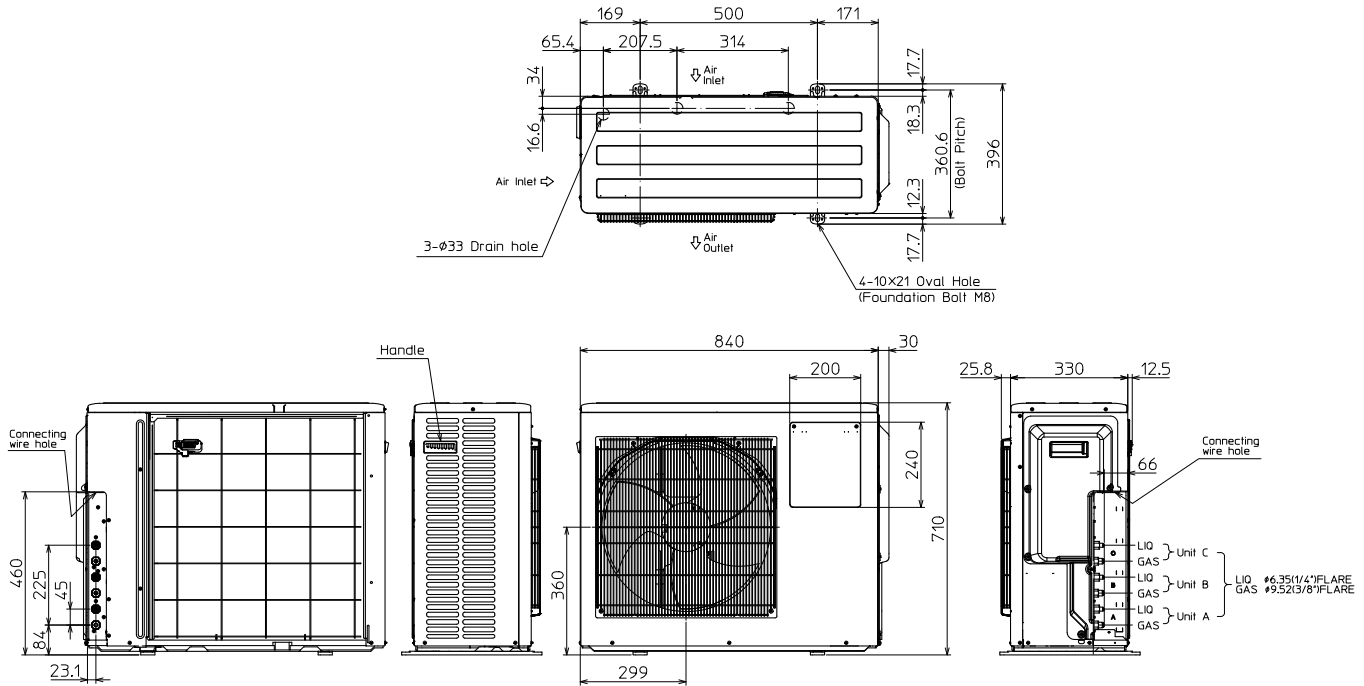

1. Installation space

Note : Leave front and both sides free of obstruction.

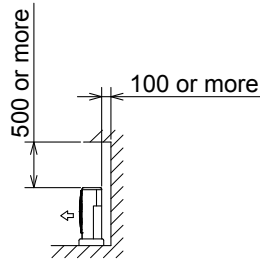

Note : Leave front and overhead free of obstruction.

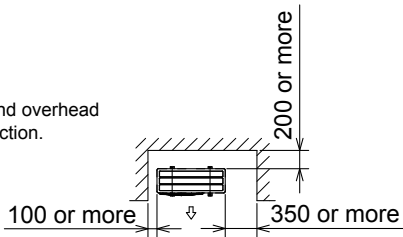

Note : Leave rear, overhead and both sides free of obstruction.

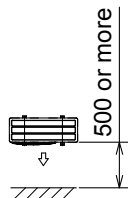

2. Service space

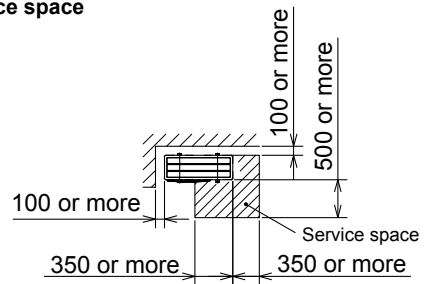

MXZ-4E72VA

Unit: mm

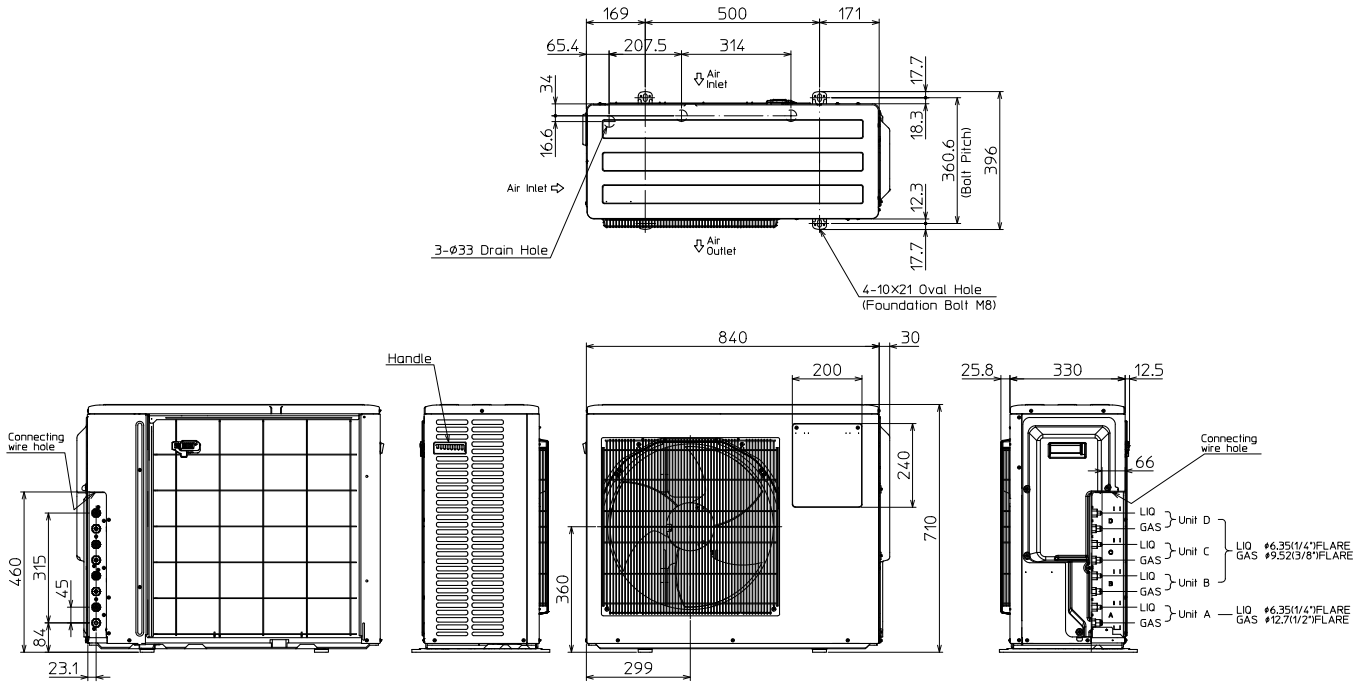

1. Installation space

Note : Leave front and both sides free of obstruction.

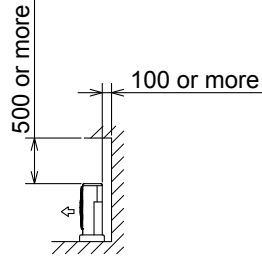

Note : Leave front and overhead free of obstruction.

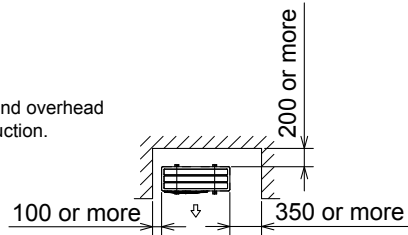

Note : Leave rear, overhead and both sides free of obstruction.

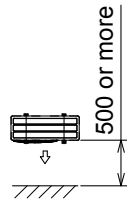

2. Service space

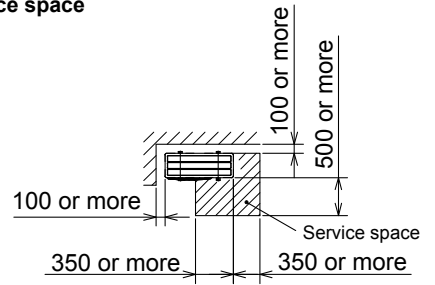

MXZ-4E83VA

Unit: mm

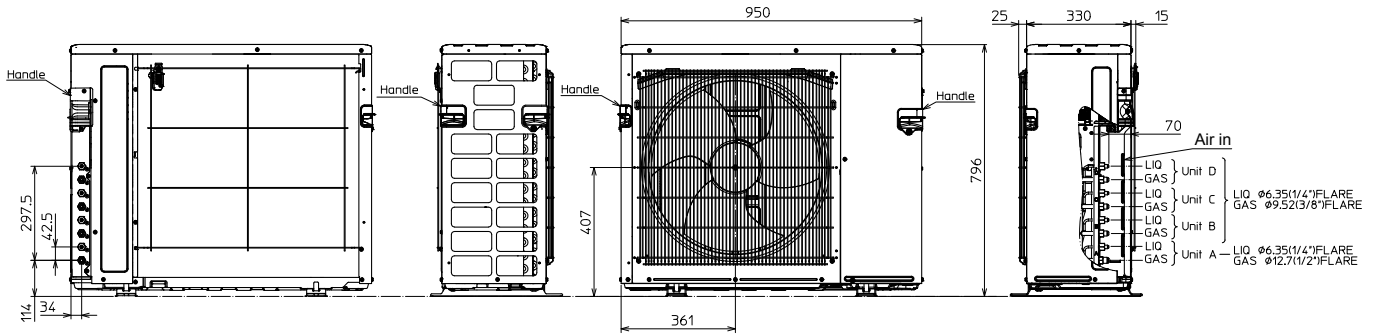
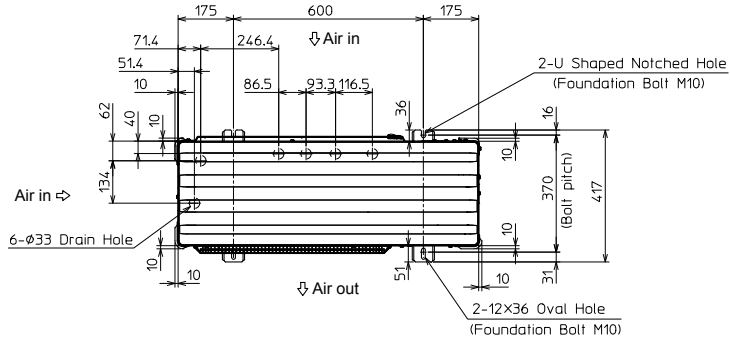

1.FREE SPACE

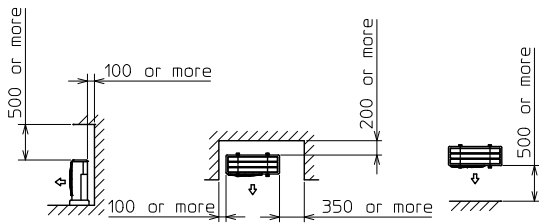

2.SERVICE SPACE

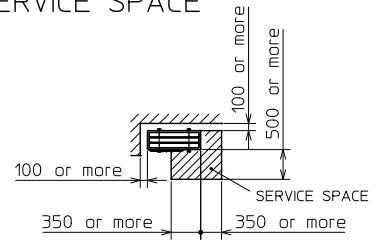



MXZ-5E102VA

Unit: mm

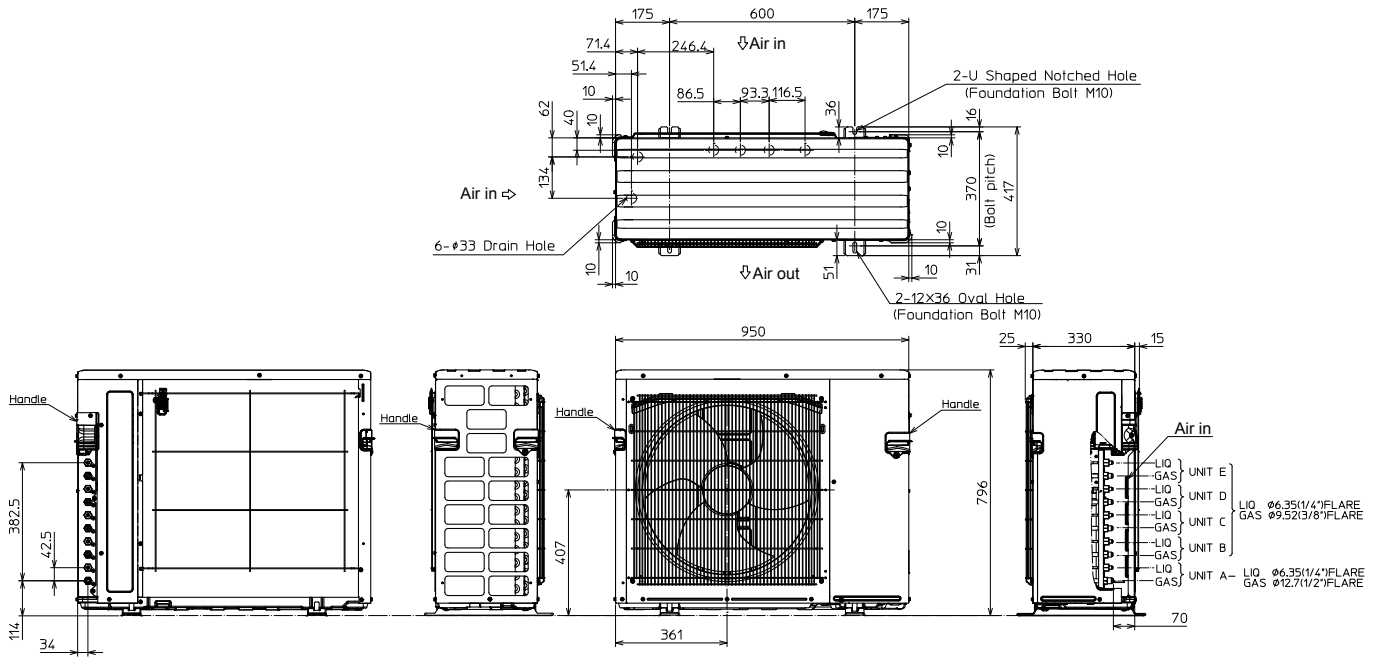

1.FREE SPACE

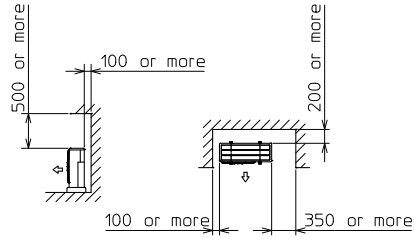

2.SERVICE SPACE

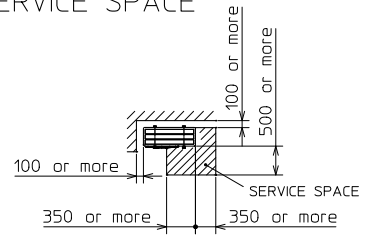

MXZ-2E53VAHZ

Unit: mm

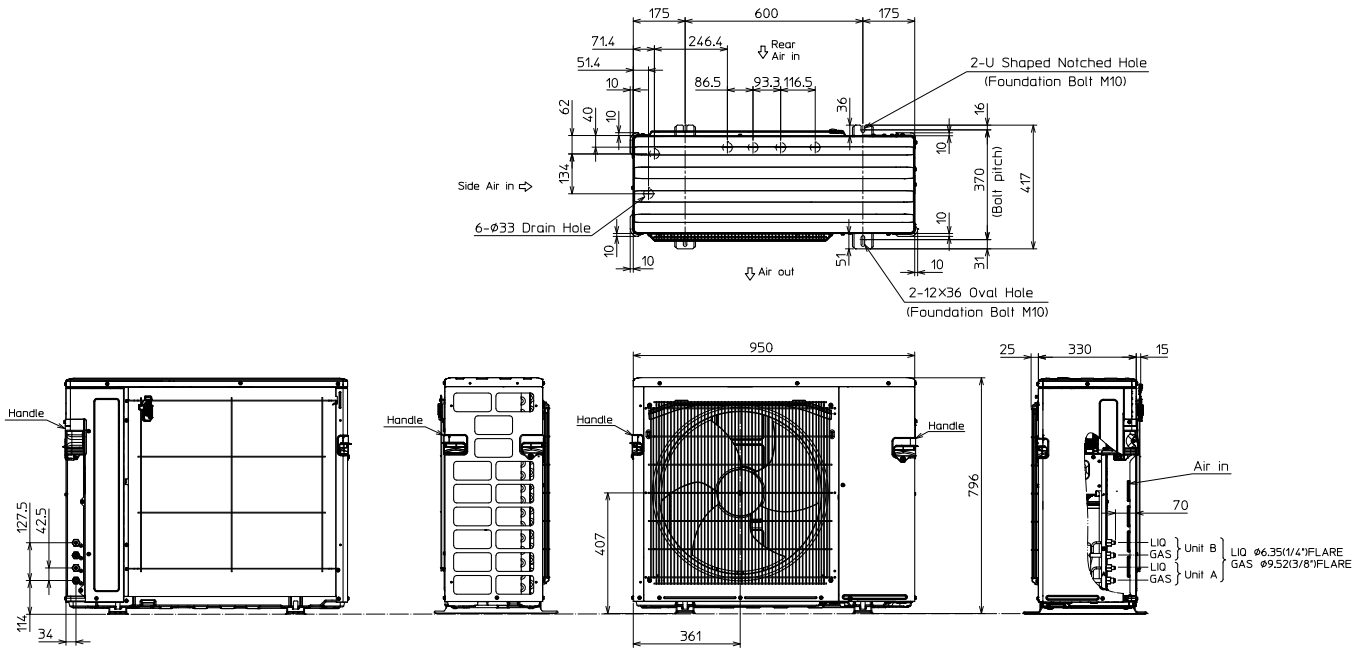

1.FREE SPACE

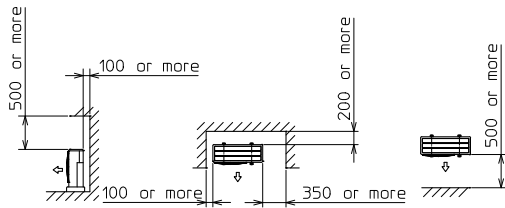

2.SERVICE SPACE

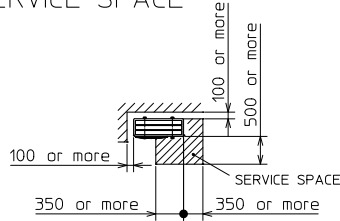

MXZ-4E83VAHZ

Unit: mm

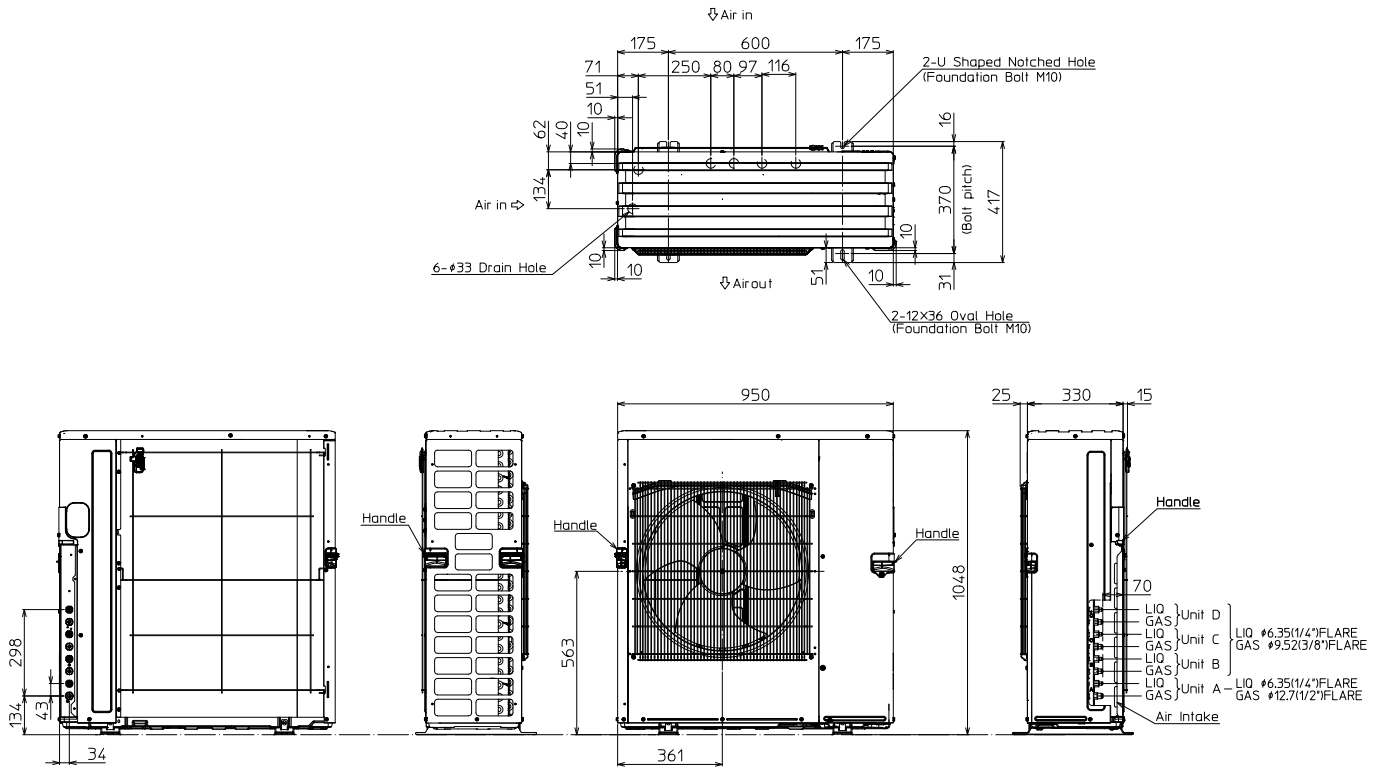

1.FREE SPACE

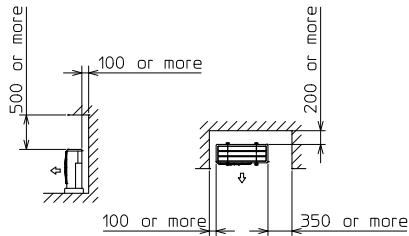

2.SERVICE SPACE

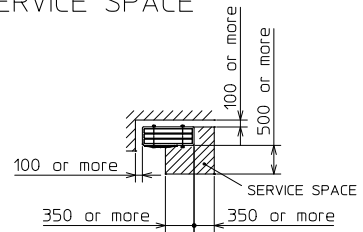

MXZ-3E54VA - [E1] MXZ-3E54VA - [ET1] MXZ-3E54VA - [ER1]
 MXZ-3E68VA - [E1] MXZ-3E68VA - [ET1] MXZ-3E68VA - [ER1]

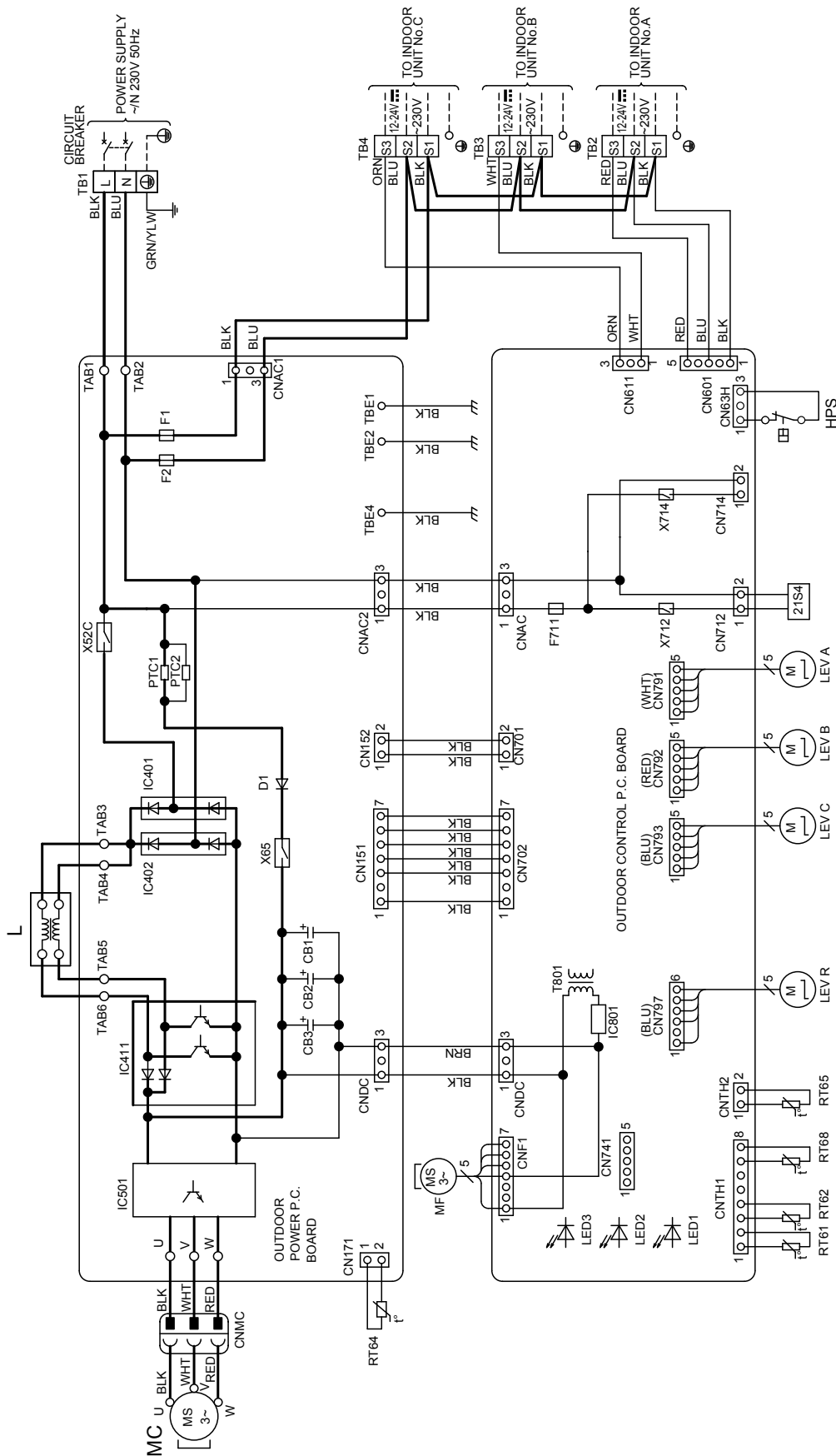

NOTES:
 1. About the indoor side electric wiring refer to the indoor unit electric wiring diagram for servicing.
 2. Use copper conductors only (For field wiring).
 3. Symbols below indicate:
 □ Terminal block
 ○ Connector

SYMBOL	NAME	SYMBOL	NAME	SYMBOL	NAME	SYMBOL	NAME
CB1-3	SMOOTHING CAPACITOR	IC401,402	DIODE BRIDGE	LEV A-CR	EXPANSION VALVE COIL	RT64	FIN TEMP. THERMISTOR
D1	DIODE	IC411	POWER FACTOR CONTROLLER	MC	COMPRESSOR	RT65	AMBIENT TEMP. THERMISTOR
F1	FUSE(T6.3AL250V)	IC501	POWER MODULE	MF	FAN MOTOR	RT68	OUTDOOR HEAT EXCHANGER
F2	FUSE(T6.3AL250V)	IC801	POWER DEVICE	PTC1,2	CIRCUIT PROTECTION	RT61	TEMPERATURE THERMISTOR
F711	FUSE(T3.15AL250V)	L	REACTOR	RT61	DEFROST THERMISTOR	T801	TRANSFORMER
HPS	HIGH PRESSURE SWITCH	LED1-3	LED	RT62	DISCHARGE TEMP. THERMISTOR	TB1-4	TERMINAL BLOCK
						X52C	RELAY
						X65	RELAY
						X712	RELAY
						X714	RELAY
						Z1S4	REVERSING VALVE SOLENOID COIL

MXZ-4E72VA - E1 MXZ-4E72VA - ET1 MXZ-4E72VA - ER1

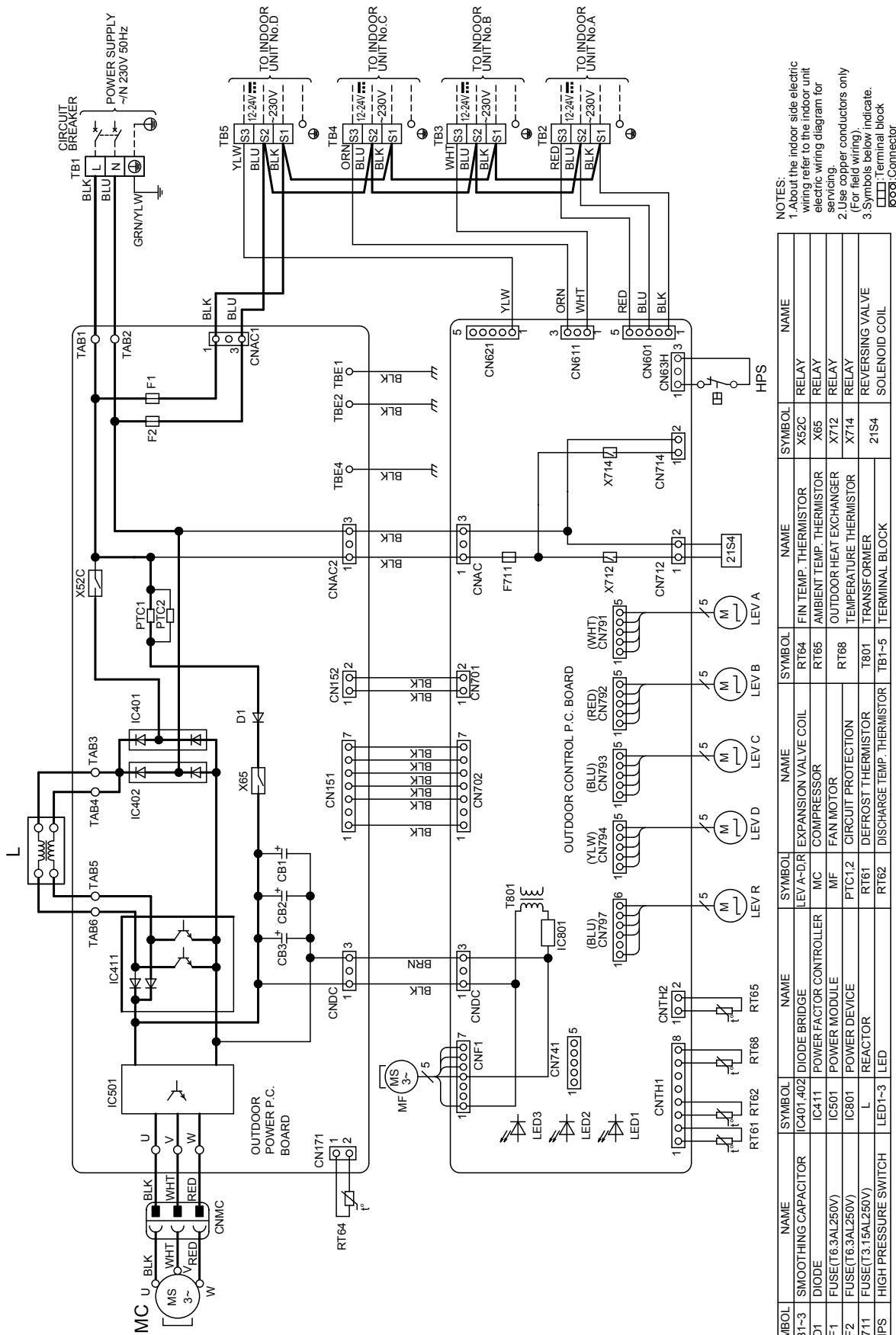

NOTES:
 1. About the indoor side electric wiring refer to the indoor unit electric wiring diagram for servicing.
 2. Use copper conductors only (For field wiring).
 3. Symbols below indicate.
 □ □ □ : terminal block
 □ □ □ □ : Connector

SYMBOL	NAME	SYMBOL	NAME	SYMBOL	NAME	SYMBOL	NAME
CB1-3	SMOOTHING CAPACITOR	IC401, 402	DIODE BRIDGE	LEV A-DR	EXPANSION VALVE COIL	RT64	FIN TEMP. THERMISTOR
D1	DIODE	IC411	POWER FACTOR CONTROLLER	MC	COMPRESSOR	RT65	AMBIENT TEMP. THERMISTOR
F1	FUSE(T6.3AL250V)	IC501	POWER MODULE	MF	FAN MOTOR	RT68	OUTDOOR HEAT EXCHANGER
F2	FUSE(T6.3AL250V)	IC801	POWER DEVICE	PTC1.2	CIRCUIT PROTECTION	X712	TEMPERATURE THERMISTOR
F711	FUSE(T3.15AL250V)	L	REACTOR	RT61	DEFROST THERMISTOR	T801	TRANSFORMER
HPS	HIGH PRESSURE SWITCH	LED1-3	LED	RT62	DISCHARGE TEMP. THERMISTOR	TBT-5	SOLENOID COIL

MXZ-4E83VA - E1

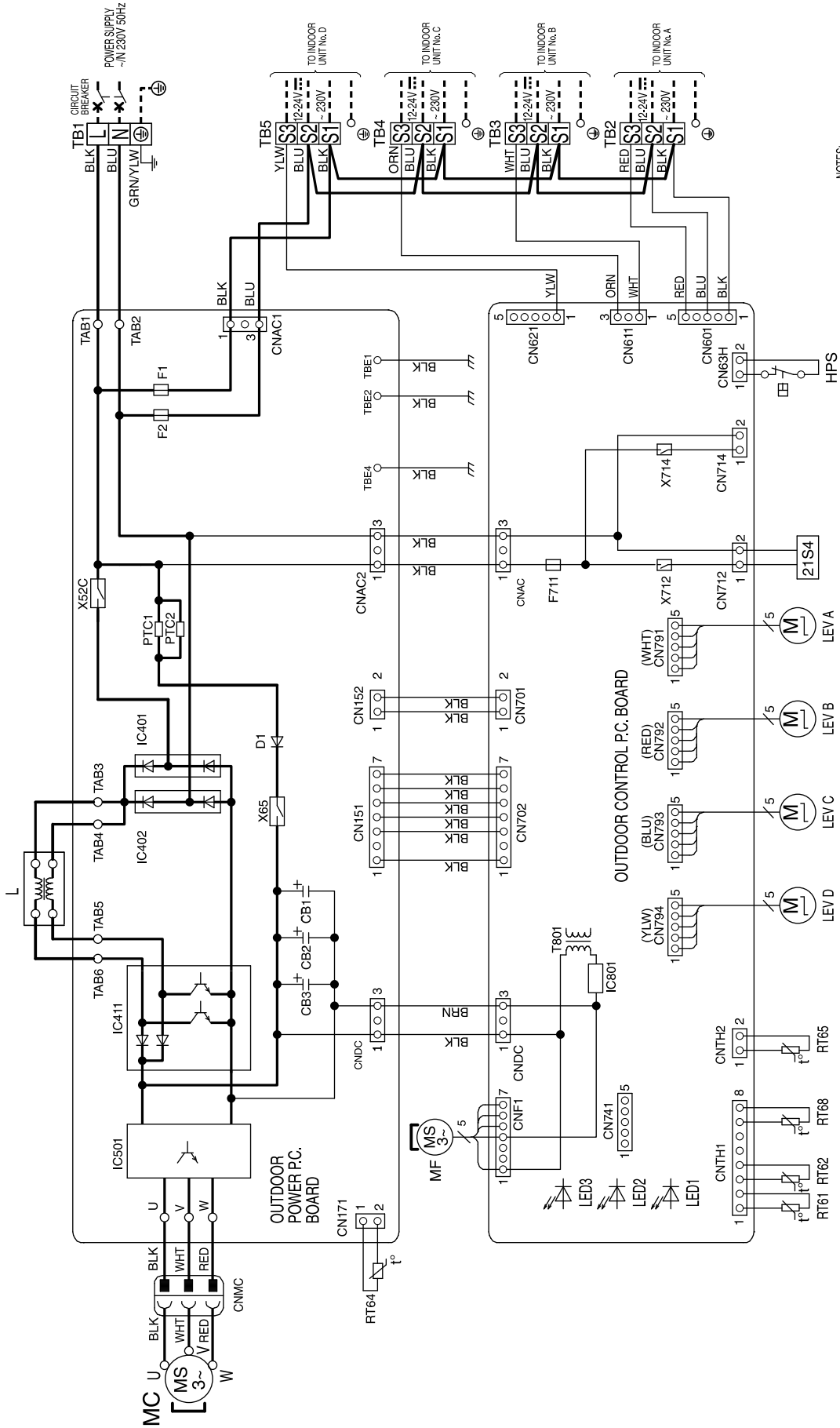

- NOTES:
1. About the indoor side electric wiring, refer to the indoor unit electric wiring diagram for site wiring.
 2. Use copper conductors only (For field wiring).
 3. Symbols below indicate.
 - : terminal block
 - : connector

SYMBOL	NAME	SYMBOL	NAME	SYMBOL	NAME	SYMBOL	NAME
CB1-3	SMOOTHING CAPACITOR	IC401, 402	DIODE BRIDGE	LEV A-D	EXPANSION VALVE	X712	RELAY
D1	DIODE	IC411	POWER FACTOR CONTROLLER	RT64	FIN TEMP. THERMISTOR	X714	RELAY
F1	FUSE (16.3AL, 250V)	IC501	POWER MODULE	RT65	AMBIENT TEMP. THERMISTOR	T801	TRANSFORMER
F2	FUSE (16.3AL, 250V)	IC801	POWER DEVICE	RT66	OUTDOOR HEAT EXCHANGER	TB1-5	TERMINAL BLOCK
F711	FUSE (3.15AL, 250V)	L	REACTOR	X52C	TEMPERATURE THERMISTOR	21S4	REVERSING VALVE
HPS	HIGH PRESSURE SWITCH	RT61	DEFROST THERMISTOR	X65	DISCHARGE TEMP. THERMISTOR		SOLENOID COIL

MXZ-4E83VA - E2

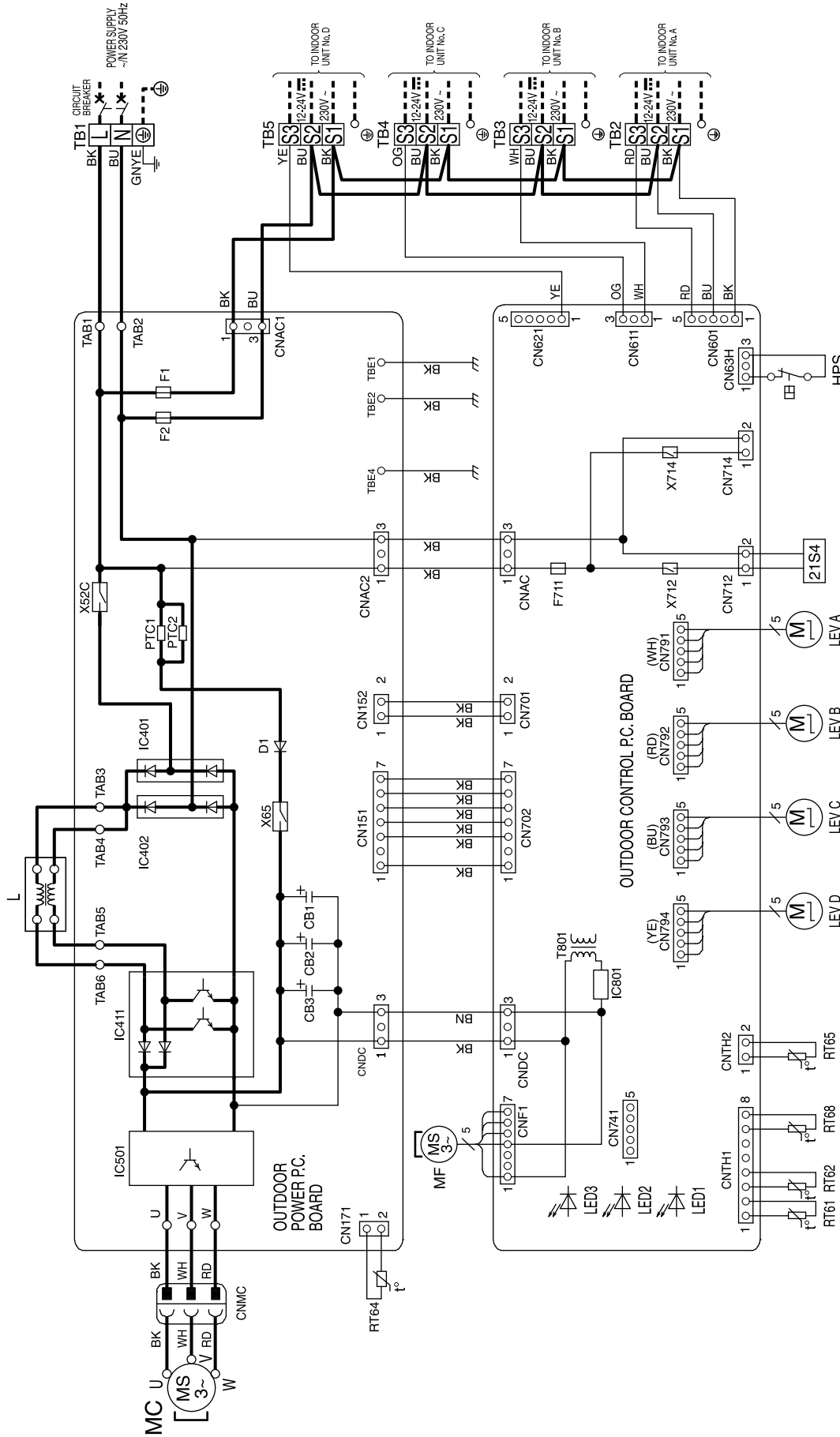

- NOTES:
1. About the indoor side electric wiring refer to the indoor unit electric wiring diagram for servicing.
 2. Use copper conductors only (For field wiring).
 3. Symbols below indicate.
 - : Terminal block
 - : Connector

SYMBOL	NAME	SYMBOL	NAME	SYMBOL	NAME	SYMBOL	NAME
CB1-3	SMOOTHING CAPACITOR	IC401, 402	DIODE BRIDGE	LEV A-D	EXPANSION VALVE COIL	X52C	RELAY
D1	DIODE	IC411	POWER FACTOR CONTROLLER	RT64	FIN TEMP. THERMISTOR	X65	RELAY
F1	FUSE (T6.3AL 250V)	IC501	POWER MODULE	RT65	AMBIENT TEMP. THERMISTOR	X72	RELAY
F2	FUSE (T6.3AL 250V)	IC801	POWER DEVICE	RT66	OUTDOOR HEAT EXCHANGER	X714	RELAY
F711	FUSE (T3.15AL 250V)	L	REACTOR	RT61	DEFROST THERMISTOR	X712	RELAY
HPS	HIGH PRESSURE SWITCH	LED1-3	LED	T801	TRANSFORMER	21S4	REVERSING VALVE SOLENOID COIL
		LED1-5	LED	TB1-5	TERMINAL BLOCK		

MXZ-4E83VA - E3

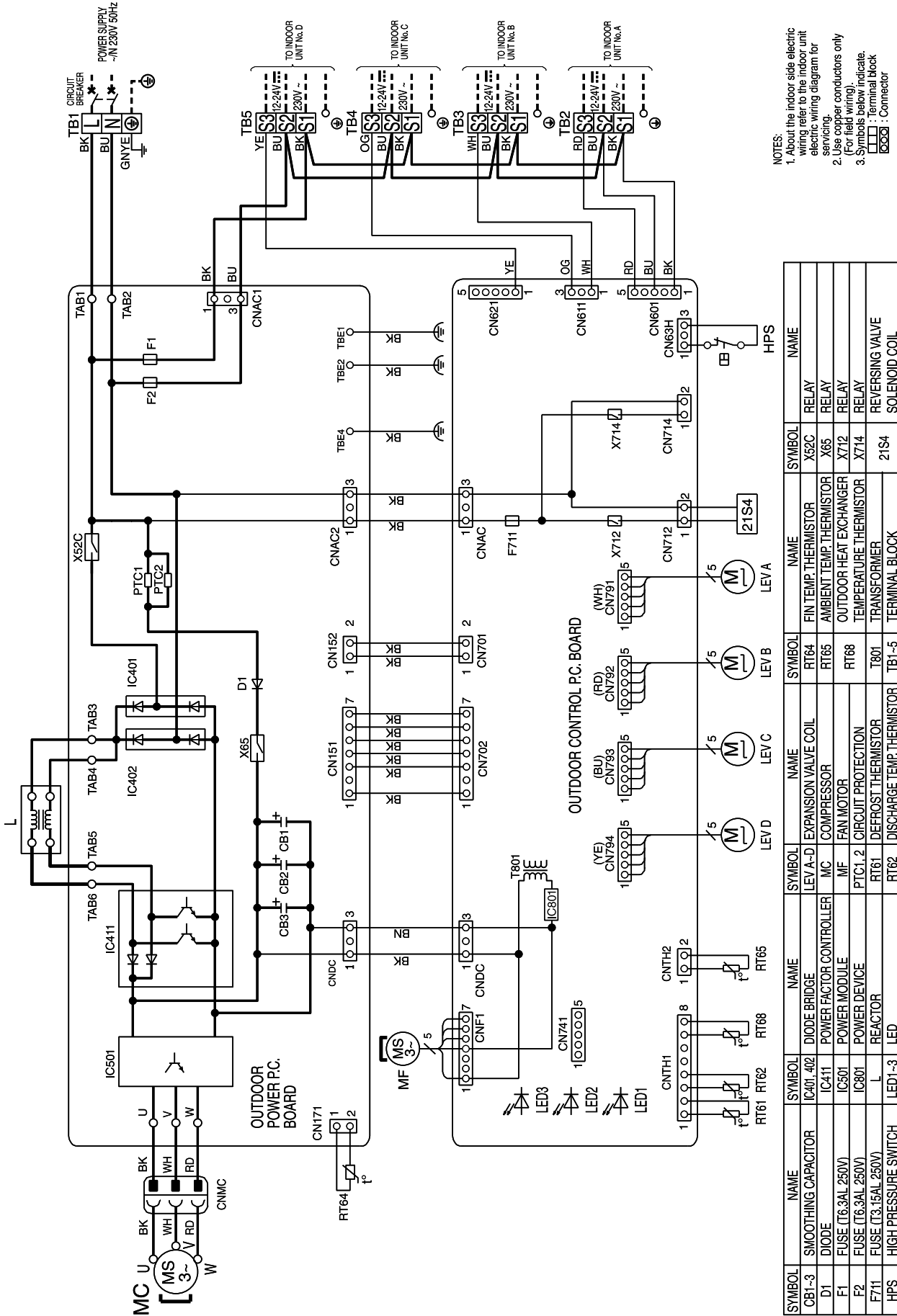

NOTES:
 1. About the indoor side electric wiring refer to the indoor unit electric wiring diagram for servicing.
 2. Use copper conductors only (for field wiring).
 3. Symbols below indicate.
 □ □ □ □ : Terminal block
 ○ ○ ○ ○ : Connector

MXZ-4E83VA - [ET1]

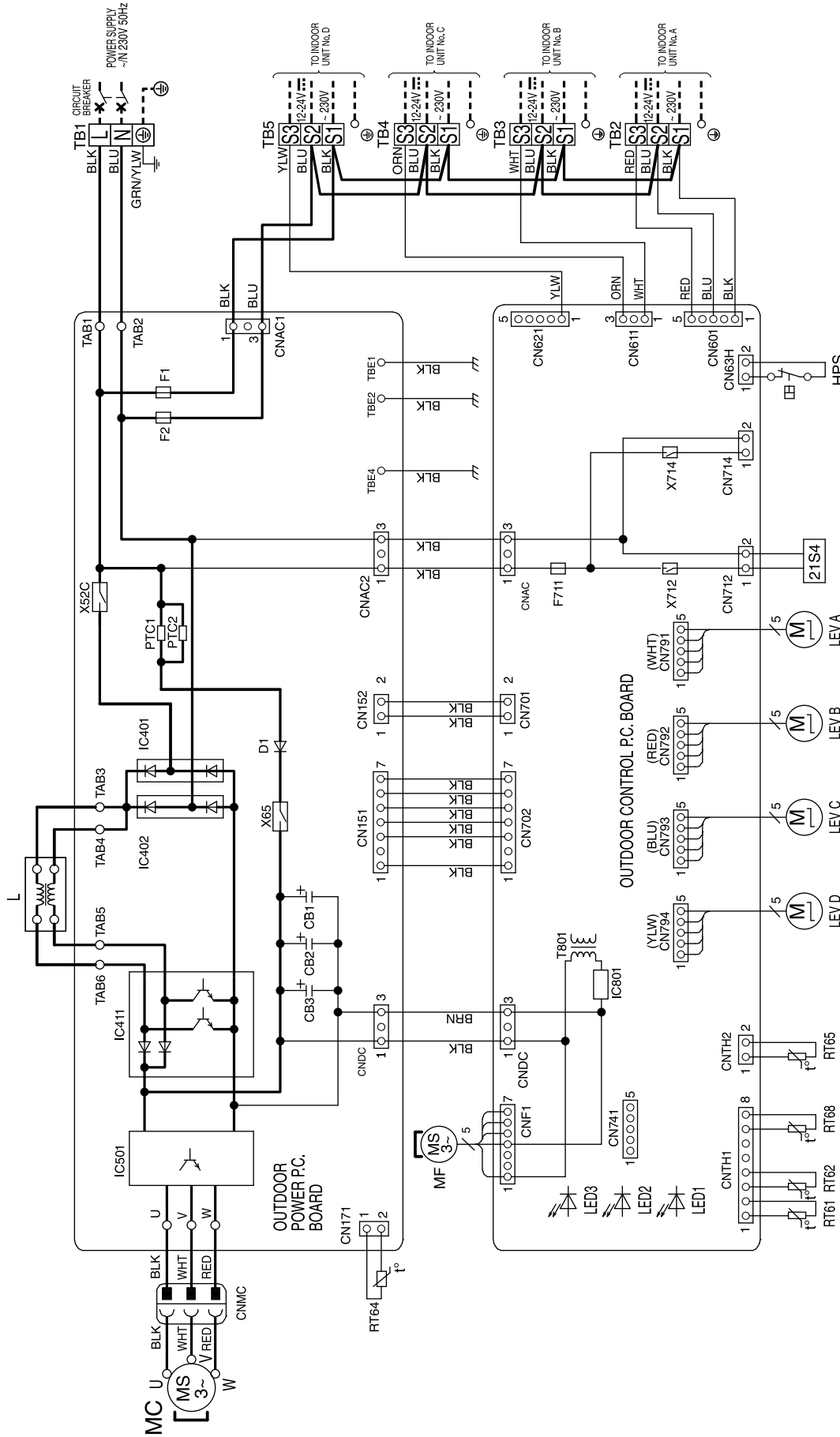

- NOTES:
1. About the indoor side electric wiring refer to the indoor unit electric wiring diagram for servicing.
 2. Use copper conductors only (For field wiring).
 3. Symbols below indicate.
 : Terminal block
 : connector

SYMBOL	NAME	SYMBOL	NAME	SYMBOL	NAME	SYMBOL	NAME
CB1-3	SMOOTHING CAPACITOR	IC401, 402	DIODE BRIDGE	LEV A-D	EXPANSION VALVE	RT64	FIN TEMP. THERMISTOR
D1	DIODE	IC411	POWER FACTOR CONTROLLER	MC	COMPRESSOR	RT65	AMBIENT TEMP. THERMISTOR
F1	FUSE (T6.3AL 250V)	IC501	POWER MODULE	MF	FAN MOTOR	T801	OUTDOOR HEAT EXCHANGER
F2	FUSE (T6.3AL 250V)	IC801	POWER DEVICE	PTC 1, 2	CIRCUIT PROTECTION	TB1-5	TERMINAL BLOCK
F711	FUSE (T3.15AL 250V)	L	REACTOR	RT61	DEFROST THERMISTOR	X52C	RELAY
HPS	HIGH PRESSURE SWITCH	LED 1-3	LED	RT62	DISCHARGE TEMP. THERMISTOR	X65	RELAY

MXZ-4E83VA - [ET2]

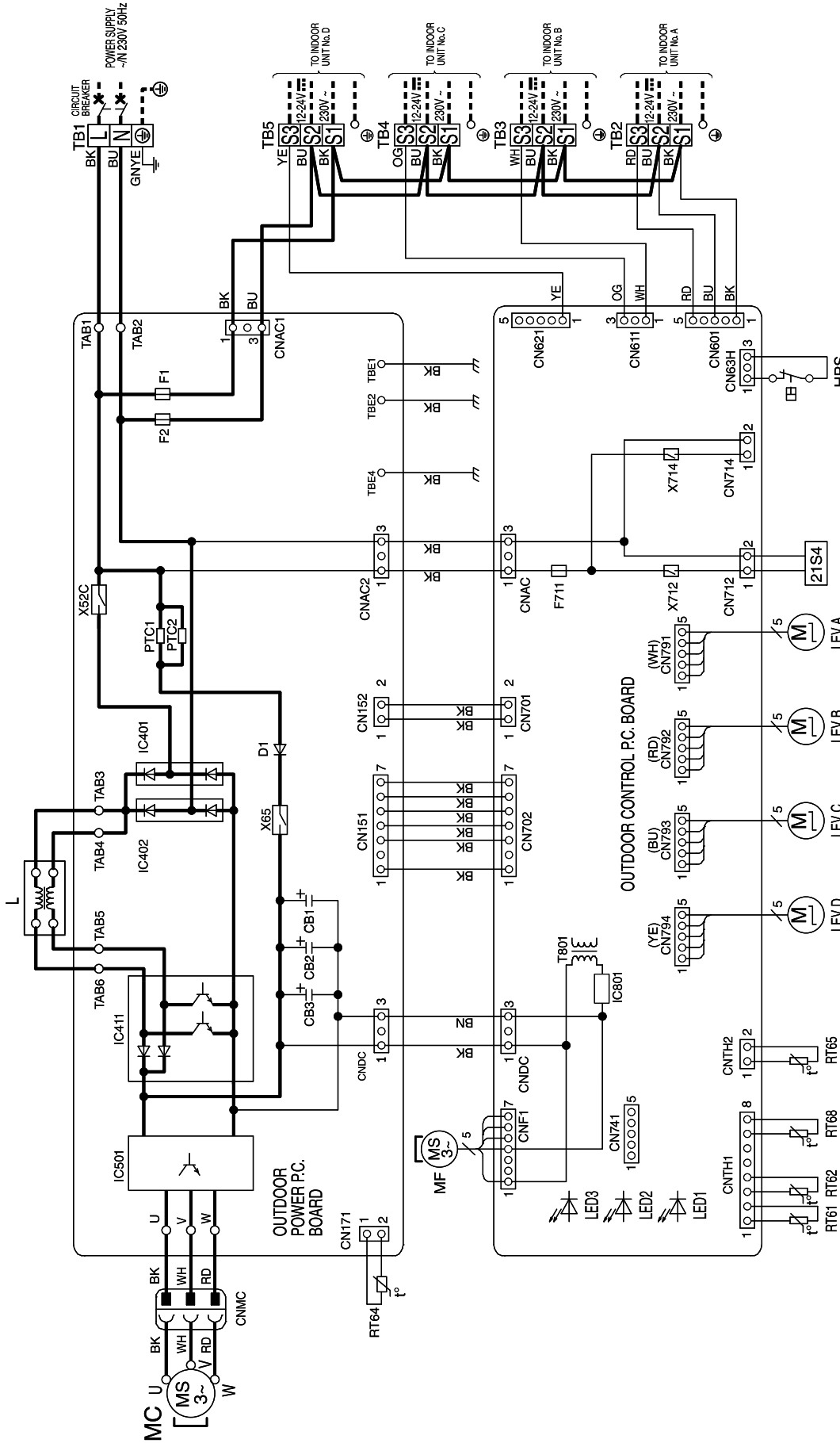

- NOTES:**
1. About the indoor side electric wiring, refer to the indoor unit electric wiring diagram for wiring.
 2. Use copper conductors only (For field wiring).
 3. Symbols below indicate.
 - : Terminal block
 - : Connector

SYMBOL	NAME	SYMBOL	NAME	SYMBOL	NAME	SYMBOL	NAME
CB1-3	SMOOTHING CAPACITOR	IC401, 402	DIODE BRIDGE	LEVA-D	EXPANSION VALVE COIL	X52C	RELAY
D1	DIODE	IC411	POWER FACTOR CONTROLLER	RT64	FIN TEMP. THERMISTOR	X65	RELAY
F1	FUSE (16.3AL, 250V)	IC501	POWER MODULE	RT65	AMBIENT TEMP. THERMISTOR	X712	RELAY
F2	FUSE (16.3AL, 250V)	IC801	POWER DEVICE	RT66	OUTDOOR HEAT EXCHANGER	X714	RELAY
F711	FUSE (3.15AL, 250V)	L	CIRCUIT PROTECTION	T801	TEMPERATURE THERMISTOR	21S4	REVERSING VALVE
HPS	HIGH PRESSURE SWITCH	LED1-3	LED	RT62	DISCHARGE TEMP. THERMISTOR		SOLENOID COIL

MXZ-4E83VA - [ET3]

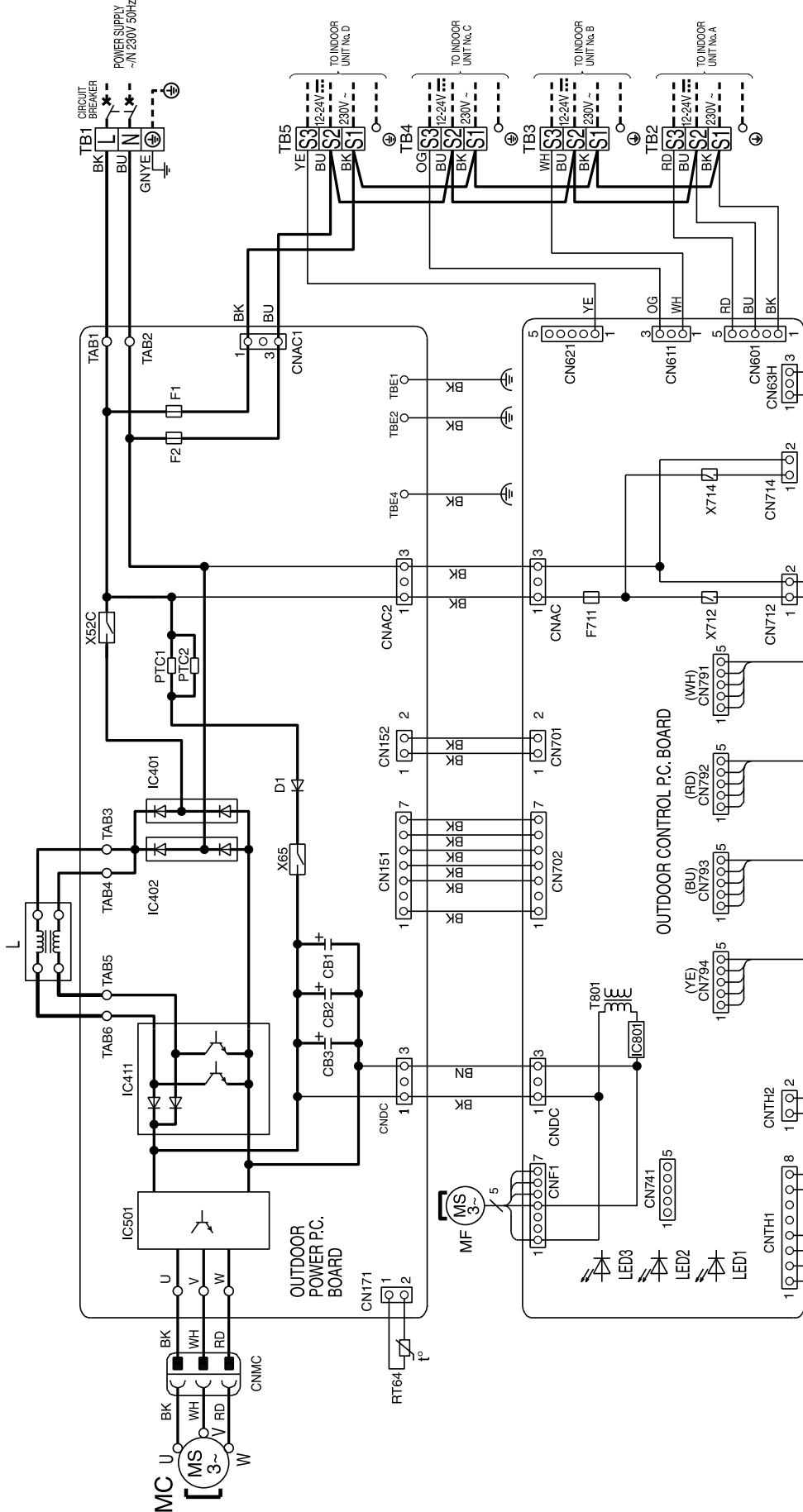

NOTES:
 1. About the indoor side electric wiring refer to the indoor unit electric wiring diagram for servicing.
 2. Use copper conductors only (For field wiring).
 3. Symbols below indicate.
 □□□□ : Terminal block
 ○○○○ : Connector

SYMBOL	NAME	SYMBOL	NAME	SYMBOL	NAME
CB1-3	SMOOTHING CAPACITOR	IC401, 402	DIODE BRIDGE	X52C	RELAY
D1	DIODE	IC411	POWER FACTOR CONTROLLER	X65	RELAY
F1	FUSE (T6.3AL 250V)	IC501	POWER MODULE	X712	RELAY
F2	FUSE (T6.3AL 250V)	IC801	POWER DEVICE	X714	RELAY
F711	FUSE (T3.15AL 250V)	L	REACTOR	T801	TRANSFORMER
HPS	HIGH PRESSURE SWITCH	LED1-3	LED	TB1-5	TERMINAL BLOCK
		LEVA-D	EXPANSION VALVE COIL	TBE1	SOLENOID COIL
		LEV A	COMPRESSOR	TBE2	
		LEV B	FAN MOTOR	TBE4	
		LEV C	CIRCUIT PROTECTION		
		LEV D	DEFROST THERMISTOR		
			DISCHARGE TEMP. THERMISTOR		
			FIN TEMP. THERMISTOR		
			AMBIENT TEMP. THERMISTOR		
			OUTDOOR HEAT EXCHANGER		
			TEMPERATURE THERMISTOR		
			TRANSFORMER		
			TERMINAL BLOCK		
			SOLENOID COIL		

MXZ-4E83VA - ER1

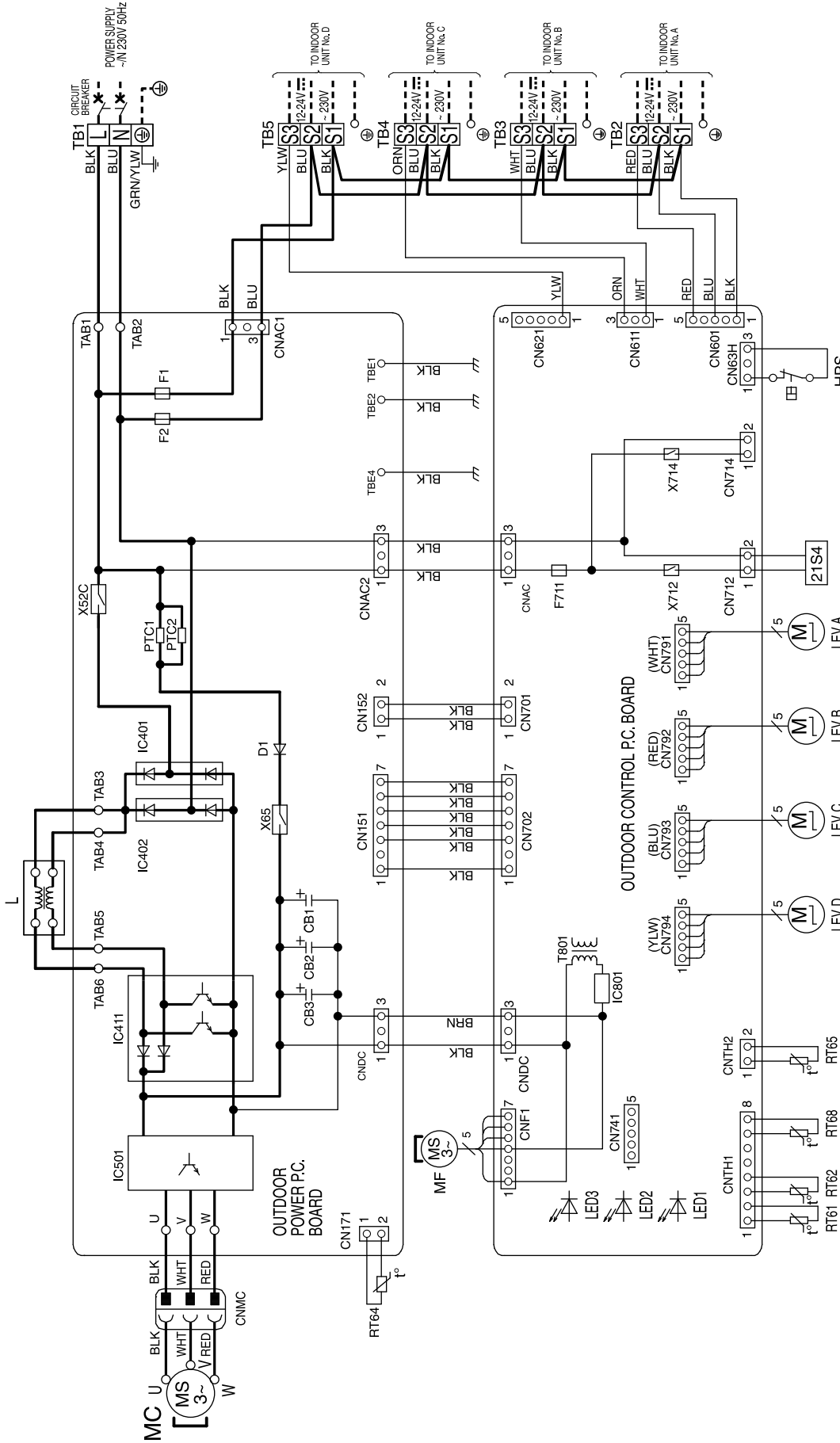

- NOTES:
1. About the indoor side electric wiring refer to the indoor unit electric wiring diagram for servicing.
 2. Use copper conductors only (for field wiring).
 3. Symbols below indicate.
 - : terminal block
 - : Connector

SYMBOL	NAME	SYMBOL	NAME	SYMBOL	NAME	SYMBOL	NAME
CB1-3	SMOOTHING CAPACITOR	IC401, 402	DIODE BRIDGE	LEV A-D	EXPANSION VALVE COIL	X52C	RELAY
D1	DIODE	IC411	POWER FACTOR CONTROLLER	RT64	FIN TEMP. THERMISTOR	X65	RELAY
F1	FUSE (T6.3AL 250V)	IC501	POWER MODULE	MC	COMPRESSOR	X712	RELAY
F2	FUSE (T6.3AL 250V)	IC801	POWER DEVICE	MF	FAN MOTOR	X714	RELAY
F71	FUSE (T3.15AL 250V)	L	REACTOR	PTC1, 2	CIRCUIT PROTECTION	21S4	SOLENOID COIL
HPS	HIGH PRESSURE SWITCH	LED1-3	LED	RT61	DEFROST THERMISTOR	RT80	TRANSFORMER
				RT62	DISCHARGE TEMP. THERMISTOR	TB1-5	TERMINAL BLOCK

MXZ-4E83VA -ER2

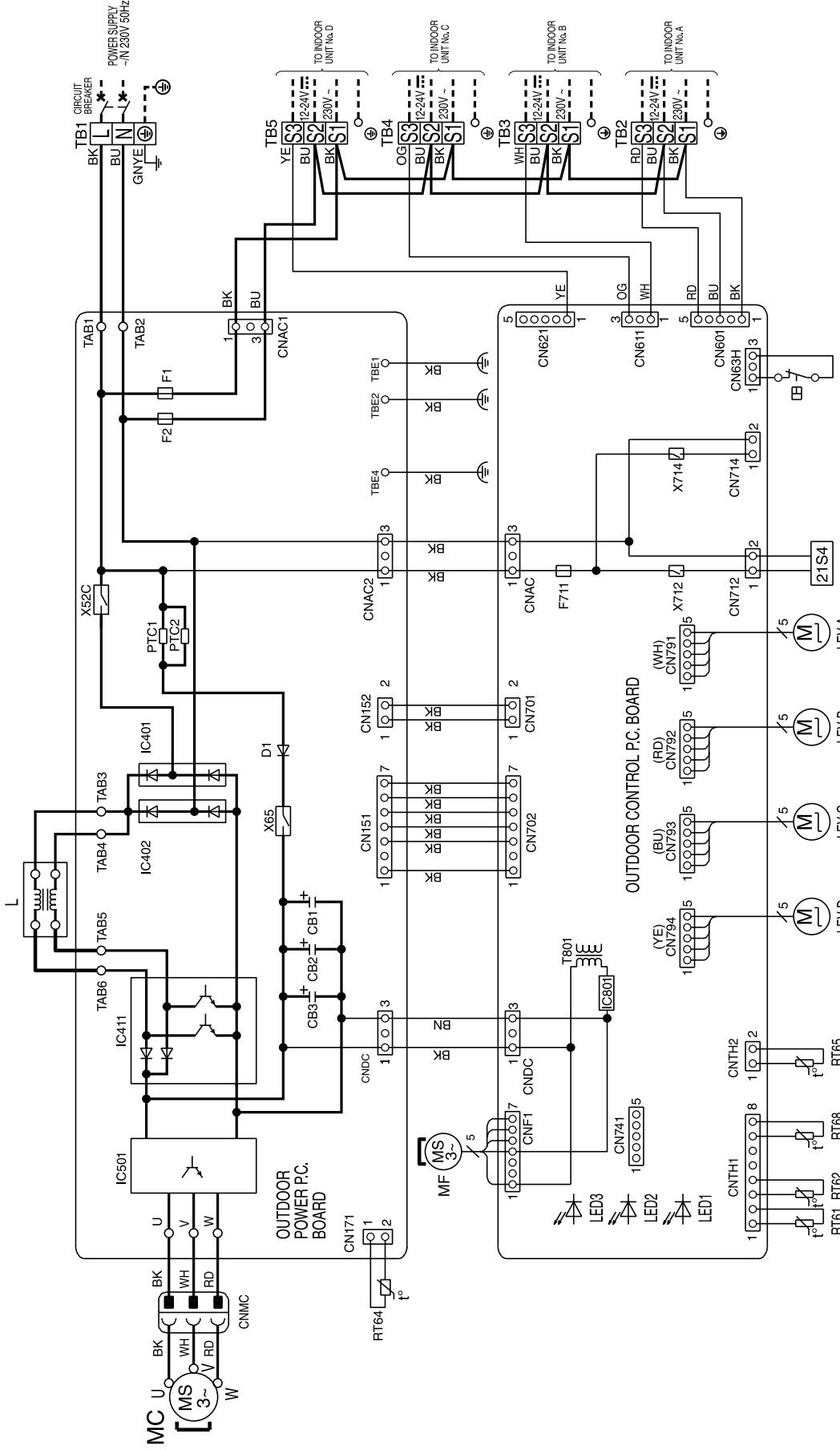

NOTES:
 1. About the indoor side electric wiring refer to the indoor unit electric wiring diagram for servicing.
 2. Use copper conductors only (For field wiring).
 3. Symbols below indicate.
 □ : Terminal block
 ○ : Connector

SYMBOL	NAME	SYMBOL	NAME	SYMBOL	NAME	SYMBOL	NAME
CB1-3	SMOOTHING CAPACITOR	IC401, 402	DIODE BRIDGE	LEV A-D	EXPANSION VALVE COIL	RT64	FIN TEMP.THERMISTOR
D1	DIODE	IC411	POWER FACTOR CONTROLLER	MC	COMPRESSOR	RT65	AMBIENT TEMP.THERMISTOR
F1	FUSE (T6.3AL 250V)	IC501	POWER MODULE	MF	FAN MOTOR	RT68	OUTDOOR HEAT EXCHANGER
F2	FUSE (T6.3AL 250V)	IC801	POWER DEVICE	PTC1, 2	CIRCUIT PROTECTION	X712	TEMPERATURE THERMISTOR
F711	FUSE (T3.15AL 250V)	L	REACTOR	RT61	DEFROST THERMISTOR	X714	TRANSFORMER
HPS	HIGH PRESSURE SWITCH	LED1-3	LED	RT62	DISCHARGE TEMP. THERMISTOR	T801	SOLENOID COIL
		LED1-3	LED	RT65	DIODE	TB1-5	TERMINAL BLOCK
		LED1-3	LED	RT66	DIODE		
		LED1-3	LED	RT67	DIODE		
		LED1-3	LED	RT68	DIODE		

MXZ-5E102VA - E1

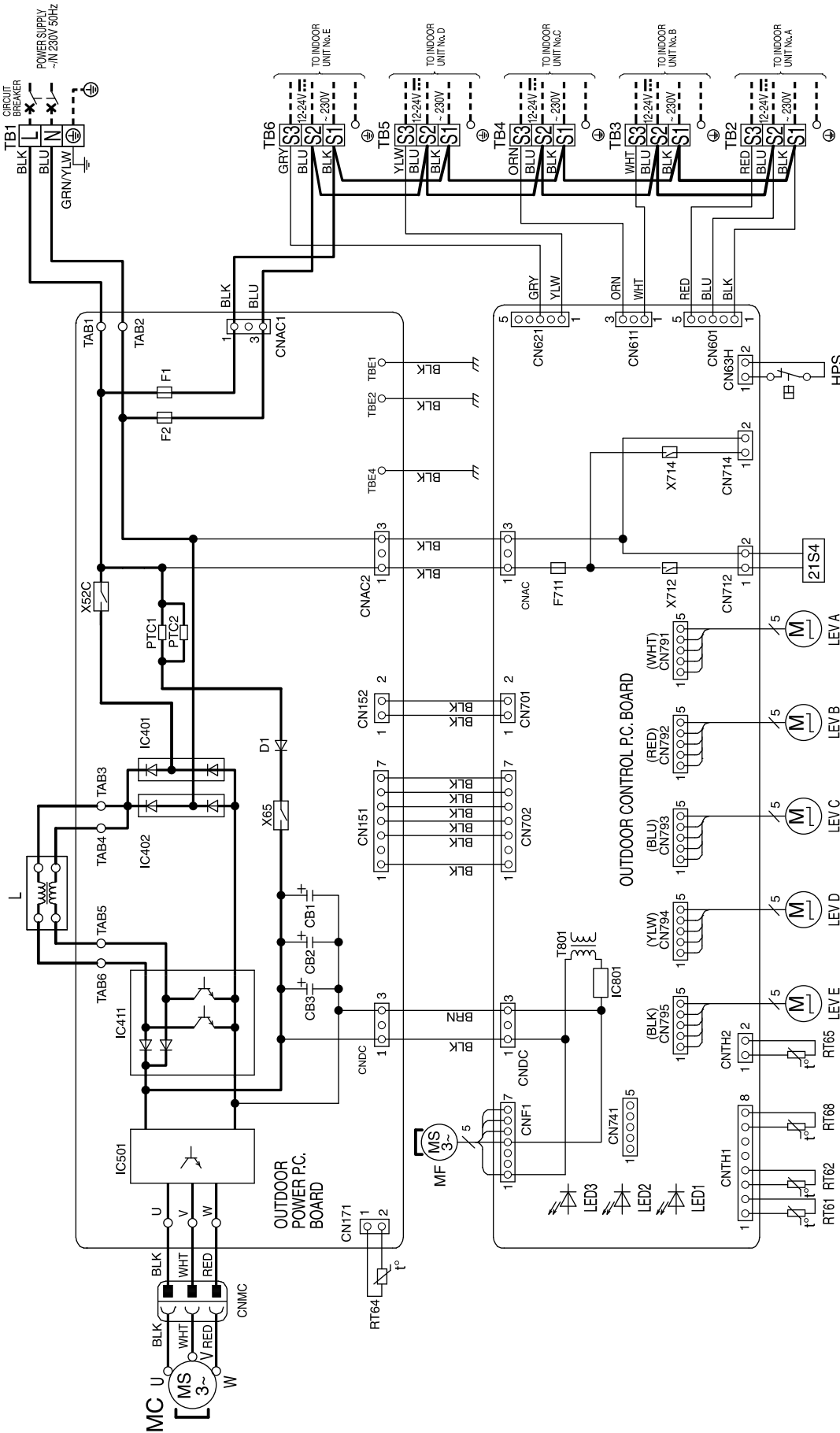

NOTES:
 1. About the indoor side electric wiring refer to the indoor unit electric wiring diagram for servicing.
 2. Use copper conductors only (For field wiring).
 3. Symbol below indicate.
 □ : Terminal block
 ⊠ : connector

SYMBOL	NAME	SYMBOL	NAME	SYMBOL	NAME	SYMBOL	NAME
CB1-3	SMOOTHING CAPACITOR	IC401, 402	DIODE BRIDGE	RT64	FIN TEMP. THERMISTOR	X712	RELAY
D1	DIODE	IC411	POWER FACTOR CONTROLLER	RT65	AMBIENT TEMP. THERMISTOR	X714	RELAY
F1	FUSE (T6.3AL 250V)	IC501	POWER MODULE	MF	OUTDOOR HEAT EXCHANGER	T801	TRANSFORMER
F2	FUSE (T6.3AL 250V)	IC801	POWER DEVICE	PTC-1.2	CIRCUIT PROTECTION	TB1-6	TERMINAL BLOCK
F711	FUSE (T3.15AL 250V)	L	REACTOR	RT61	DEFROST THERMISTOR	RELAY	REVERSING VALVE
HPS	HIGH PRESSURE SWITCH	LED1-3	LED	RT62	DISCHARGE TEMP. THERMISTOR	RELAY	SOLENOID COIL

MXZ-5E102VA - E2

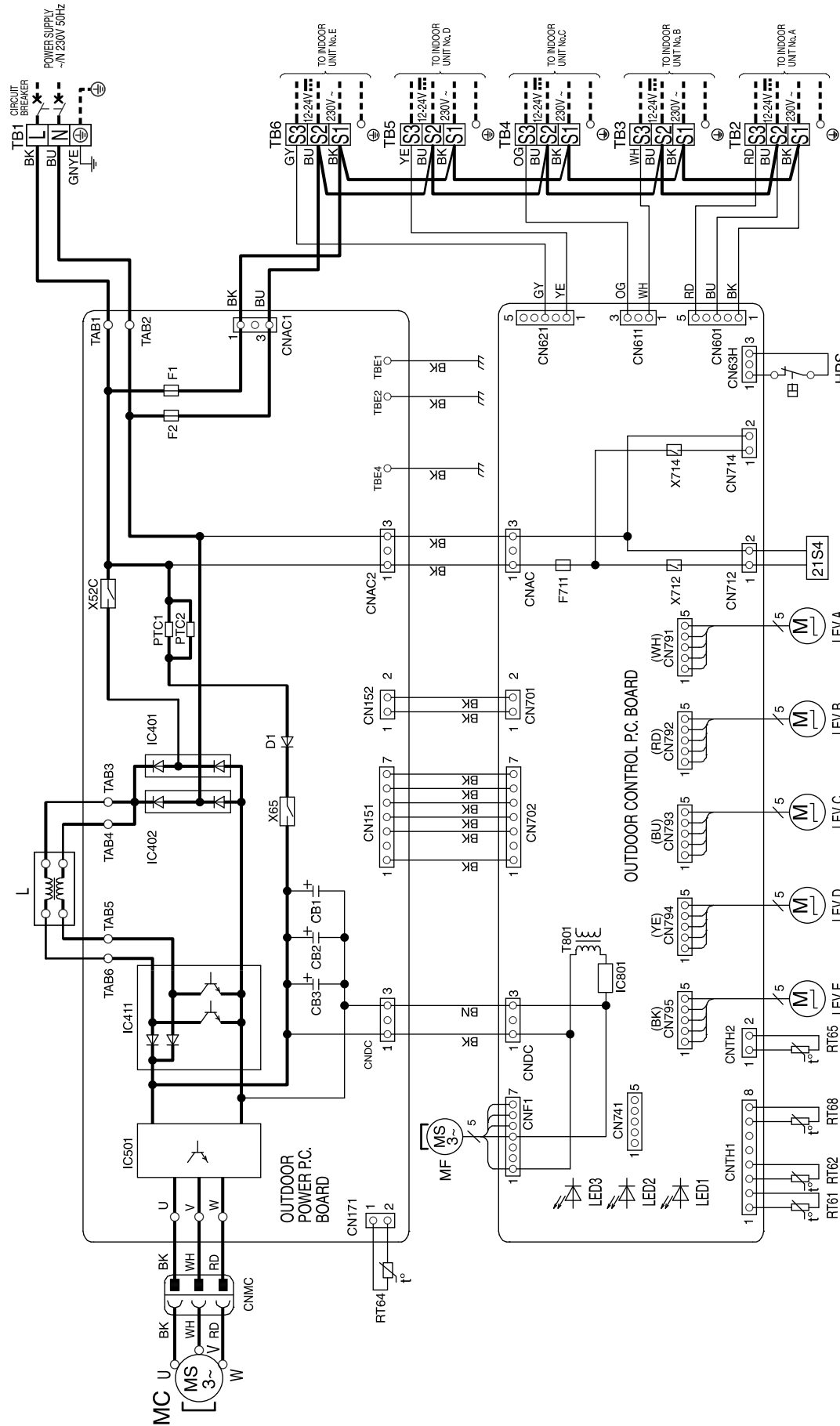

- NOTES:**
1. About the indoor side electric wiring, refer to the indoor unit electric wiring diagram for servicing.
 2. Use copper conductors only (for field wiring).
 3. Symbols below indicate.
 - : Terminal block
 - : Connector

SYMBOL	NAME	SYMBOL	NAME	SYMBOL	NAME
CB1-3	SMOOTHING CAPACITOR	IC401, 402	DIODE BRIDGE	RT64	LEV A-E EXPANSION VALVE COIL
D1	DIODE	IC411	POWER FACTOR CONTROLLER	MC	COMPRESSOR
F1	FUSE (T6.3AL 250V)	IC501	POWER MODULE	MF	FAN MOTOR
F2	FUSE (T6.3AL 250V)	IC801	POWER DEVICE	PTC1, 2	CIRCUIT PROTECTION
F711	FUSE (T3.15AL 250V)	L	REACTOR	RT61	DEFROST THERMISTOR
HPS	HIGH PRESSURE SWITCH	LED1-3	LED	RT62	DISCHARGE TEMP.THERMISTOR
				TB1-6	TERMINAL BLOCK
				21S4	SOLENOID COIL

MXZ-5E102VA - E3

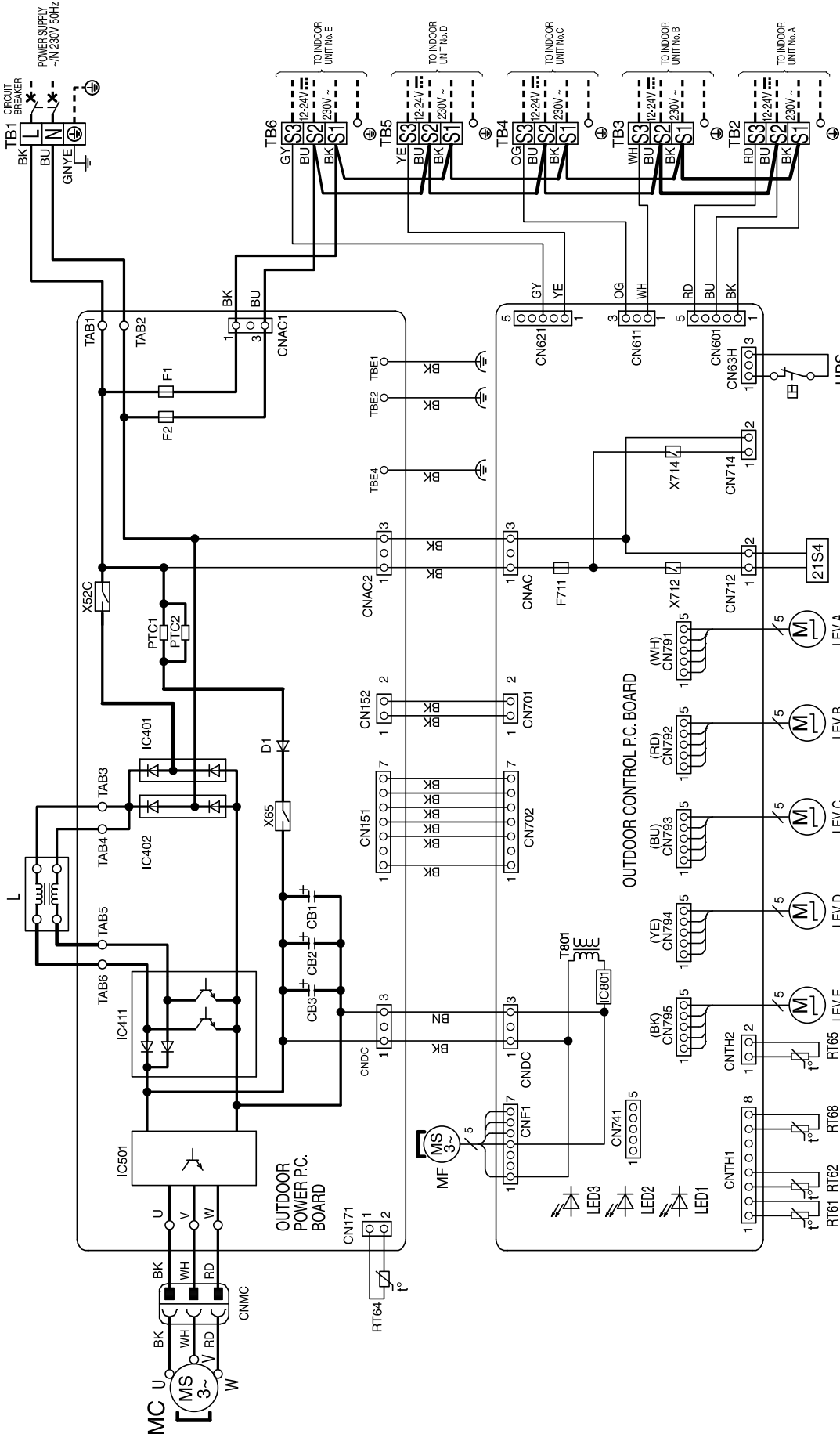

NOTES:
 1. About the indoor side electric wiring refer to the indoor unit electric wiring diagram for servicing.
 2. Use copper conductors only (For field wiring).
 3. Symbols below indicate.
 □□□□ : Terminal block
 ○○○○ : Connector

SYMBOL	NAME	SYMBOL	NAME	SYMBOL	NAME
CB1-3	SMOOTHING CAPACITOR	RT64	FIN TEMP.THERMISTOR	X52C	RELAY
D1	DIODE	RT65	AMBIENT TEMP.THERMISTOR	X65	RELAY
F1	FUSE (T6.3AL 250V)	RT68	OUTDOOR HEAT EXCHANGER	X712	RELAY
F2	FUSE (T6.3AL 250V)	IC801	TEMPERATURE THERMISTOR	X714	RELAY
F711	FUSE (T3.15AL 250V)	L	TRANSFORMER		REVERSING VALVE
HPS	HIGH PRESSURE SWITCH	RT62	DISCHARGE TEMP.THERMISTOR	21S4	SOLENOID COIL
LED1-3	LED	RT61	DEFROST THERMISTOR		
IC401	DIODE BRIDGE	RT66	EXPANSION VALVE COIL		
IC411	POWER FACTOR CONTROLLER	MC	COMPRESSOR		
IC501	FUSE (T6.3AL 250V)	MF	FAN MOTOR		
IC801	POWER DEVICE	PTC1, 2	CIRCUIT PROTECTION		
L	FUSE (T3.15AL 250V)	RT61	DEFROST THERMISTOR		
		RT62	DISCHARGE TEMP.THERMISTOR		
		RT64	FIN TEMP.THERMISTOR		
		RT65	AMBIENT TEMP.THERMISTOR		
		RT68	OUTDOOR HEAT EXCHANGER		
		IC801	TEMPERATURE THERMISTOR		
		L	TRANSFORMER		
		RT61	DEFROST THERMISTOR		
		RT62	DISCHARGE TEMP.THERMISTOR		
		RT66	EXPANSION VALVE COIL		
		MC	COMPRESSOR		
		MF	FAN MOTOR		
		PTC1, 2	CIRCUIT PROTECTION		
		21S4	SOLENOID COIL		
		X52C	RELAY		
		X65	RELAY		
		X712	RELAY		
		X714	RELAY		

MXZ-5E102VA - [ET1]

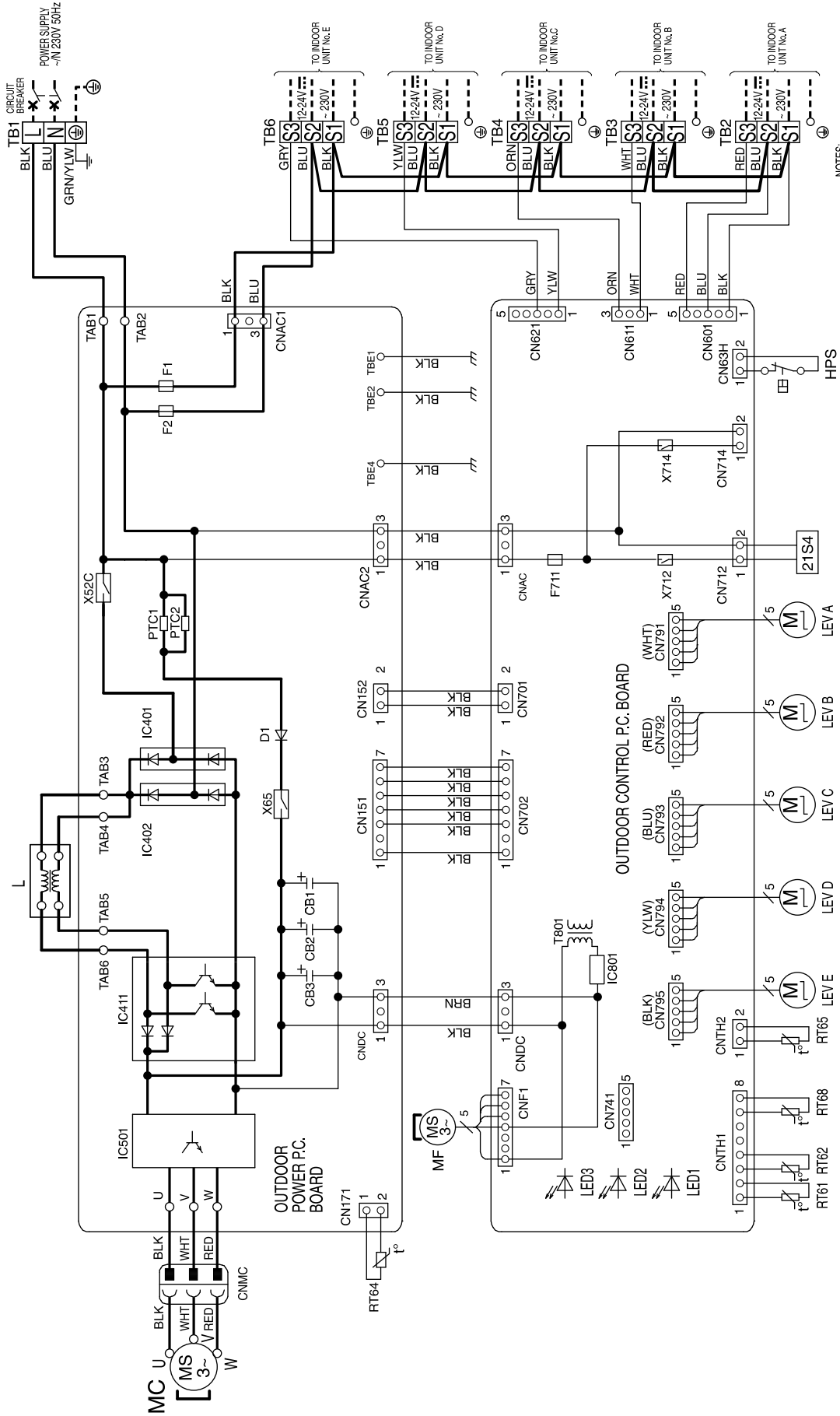

- NOTES:
1. About the indoor side electric wiring, refer to the indoor unit electric wiring diagram for servicing.
 2. Use copper conductors only (for field wiring).
 3. Symbols below indicate.
 - : terminal block
 - : connector

SYMBOL	NAME	SYMBOL	NAME	SYMBOL	NAME	SYMBOL	NAME
ICB1-3	SMOOTHING CAPACITOR	IC401, 402	DIODE BRIDGE	RT64	LEV A-E EXPANSION VALVE	RT64	FIN TEMP. THERMISTOR
D1	DIODE	IC411	POWER FACTOR CONTROLLER	MC	COMPRESSOR	RT65	AMBIENT TEMP. THERMISTOR
F1	FUSE (T6.3AL 250V)	IC501	POWER MODULE	MF	FAN MOTOR	RT66	OUTDOOR HEAT EXCHANGER
F2	FUSE (T6.3AL 250V)	IC801	POWER DEVICE	PTC 1, 2	CIRCUIT PROTECTION	RT68	TEMPERATURE THERMISTOR
F711	FUSE (T3.15AL 250V)	L	REACTOR	RT61	DEFROST THERMISTOR	X52C	TEMPERATURE THERMISTOR
HPS	HIGH PRESSURE SWITCH	LED 1-3	LED	RT62	DISCHARGE TEMP. THERMISTOR	X65	RELAY
		RT62	LED 1-3	X65	RELAY	21S4	SOLENOID COIL

MXZ-5E102VA - ET2

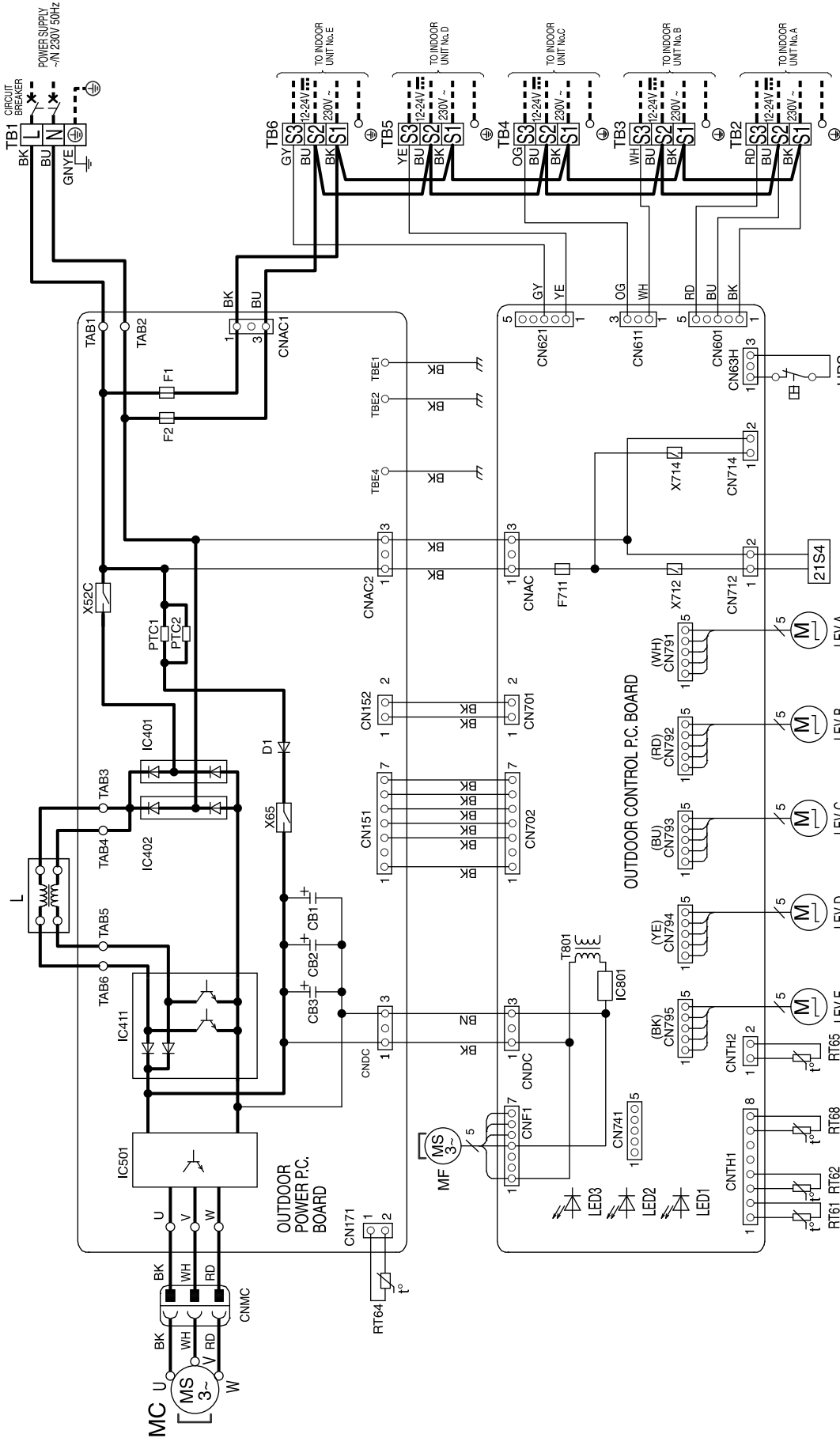

NOTES:
 1. About the indoor side electric wiring refer to the indoor unit electric wiring diagram for servicing.
 2. Use copper conductors only (For field wiring).
 3. Symbols below indicate.
 □ : Terminal block
 ○ : Connector

SYMBOL	NAME	SYMBOL	NAME	SYMBOL	NAME	SYMBOL	NAME
CB1-3	SMOOTHING CAPACITOR	IC401, 402	DIODE BRIDGE	LEV A-E	EXPANSION VALVE COIL	RT64	FIN TEMP. THERMISTOR
D1	DIODE	IC411	POWER FACTOR CONTROLLER	MC	COMPRESSOR	RT65	AMBIENT TEMP. THERMISTOR
F1	FUSE (T6.3AL 250V)	IC501	POWER MODULE	MF	FAN MOTOR	RT66	OUTDOOR HEAT EXCHANGER
F2	FUSE (T6.3AL 250V)	IC801	POWER DEVICE	PTC1, 2	CIRCUIT PROTECTION	RT68	TEMPERATURE THERMISTOR
F711	FUSE (T3.15AL 250V)	L	REACTOR	RT61	DEFROST THERMISTOR	T801	TRANSFORMER
HPS	HIGH PRESSURE SWITCH	LED1-3	LED	RT62	DISCHARGE TEMP. THERMISTOR	TB1-6	TERMINAL BLOCK
						21S4	SOLENOID COIL

MXZ-5E102VA - [ET3]

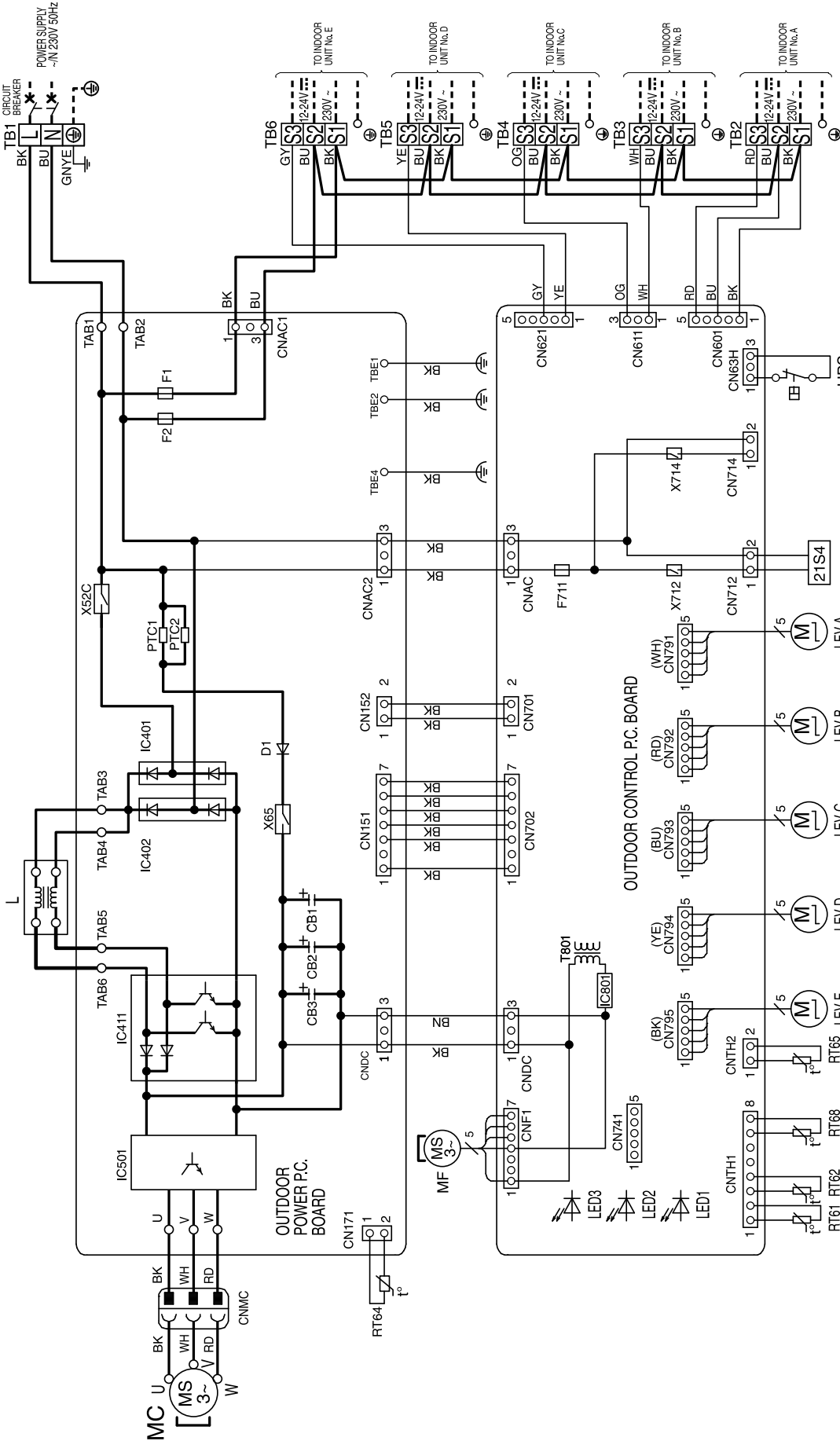

- NOTES:**
1. About the indoor side electric wiring refer to the indoor unit electric wiring diagram for servicing.
 2. Use copper conductors only (For field wiring).
 3. Symbols below indicate.
 - : Terminal block
 - : Connector

SYMBOL	NAME	SYMBOL	NAME	SYMBOL	NAME
CB1-3	SMOOTHING CAPACITOR	IC401, 402	DIODE BRIDGE	RT64	FIN TEMP. THERMISTOR
D1	DIODE	IC411	POWER FACTOR CONTROLLER	RT65	AMBIENT TEMP. THERMISTOR
F1	FUSE (T6.3AL 250V)	IC501	POWER MODULE	RT66	OUTDOOR HEAT EXCHANGER
F2	FUSE (T6.3AL 250V)	IC801	POWER DEVICE	X714	TEMPERATURE THERMISTOR
F711	FUSE (T3.15AL 250V)	L	REACTOR	T801	TRANSFORMER
HPS	HIGH PRESSURE SWITCH	LED1-3	LED	TB1-6	DISCHARGE TEMP. THERMISTOR
					TERMINAL BLOCK
				21S4	SOLENOID COIL

MXZ-5E102VA - ER1

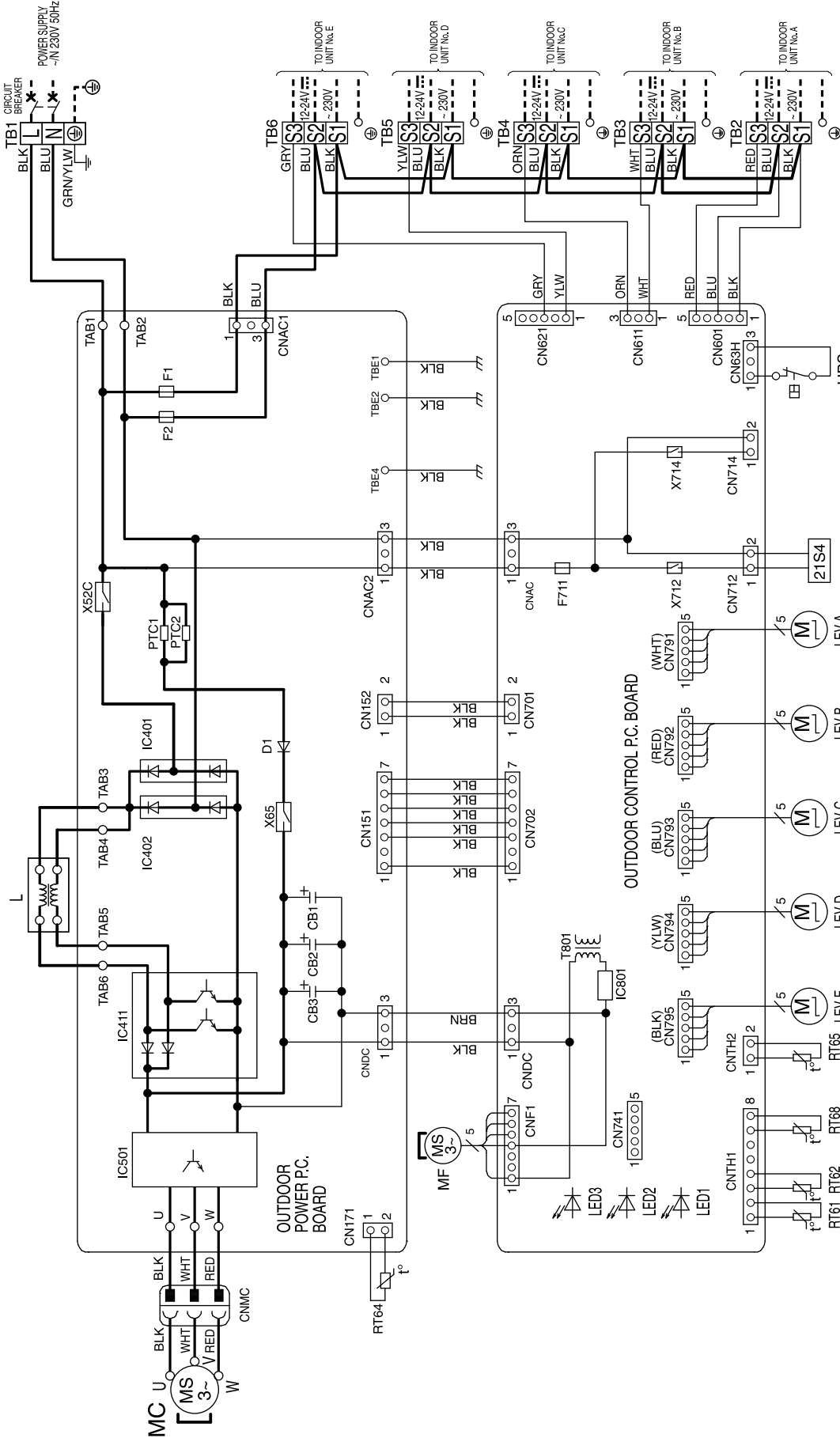

- NOTES:**
1. About the indoor side electric wiring refer to the indoor unit electric wiring diagram for servicing.
 2. Use copper conductors only (For field wiring).
 3. Symbols below indicate.
 : Terminal block
 : Connector

SYMBOL	NAME	SYMBOL	NAME	SYMBOL	NAME	SYMBOL	NAME
CB1-3	SMOOTHING CAPACITOR	IC401, 402	DIODE BRIDGE	LEV A-E	EXPANSION VALVE COIL	X52C	RELAY
D1	DIODE	IC411	POWER FACTOR CONTROLLER	MC	COMPRESSOR	X65	RELAY
F1	FUSE (T6.3AL 250V)	IC501	POWER MODULE	MF	FAN MOTOR	X712	RELAY
F2	FUSE (T6.3AL 250V)	IC801	POWER DEVICE	PTC1, 2	CIRCUIT PROTECTION	X714	RELAY
F711	FUSE (T3.15AL 250V)	L	REACTOR	RT61	DEFROST THERMISTOR	X714	RELAY
HPS	HIGH PRESSURE SWITCH	LED1-3	LED	RT62	DISCHARGE TEMP. THERMISTOR	21S4	SOLENOID COIL
				RT65	LEV E		
				RT66	LEV C		
				RT67	LEV B		
				RT68	LEV A		
				T801	TRANSFORMER		
				T802	TERMINAL BLOCK		

MXZ-5E102VA - ER2

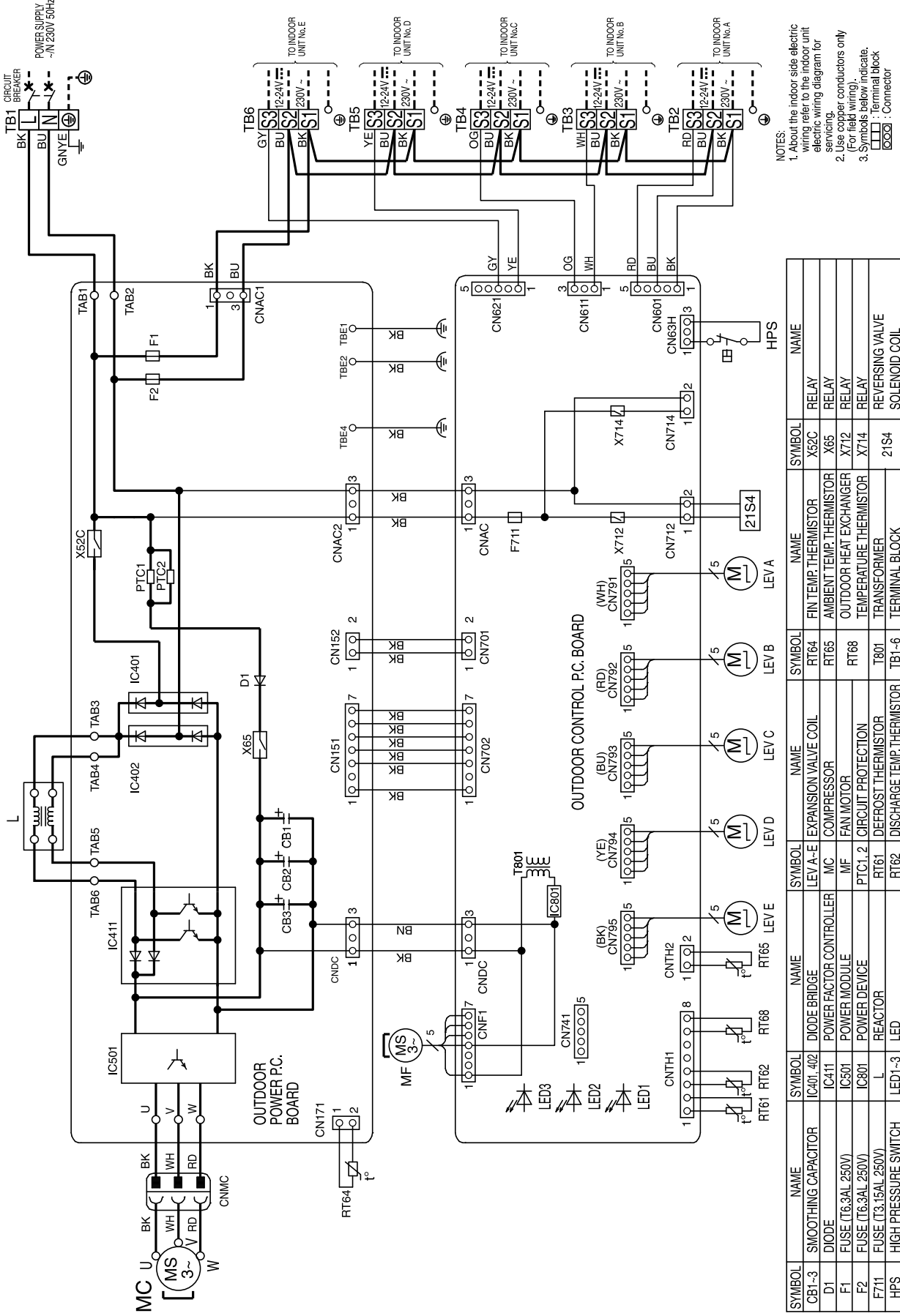

- NOTES:**
1. About the indoor side electric wiring refer to the indoor unit electric wiring diagram for servicing.
 2. Use copper conductors only (For field wiring).
 3. Symbols below indicate.
 : Terminal block
 : Connector

SYMBOL	NAME	SYMBOL	NAME	SYMBOL	NAME	SYMBOL	NAME
CB1-3	SMOOTHING CAPACITOR	IC401, 402	DIODE BRIDGE	LEV A-E	EXPANSION VALVE COIL	X52C	RELAY
D1	DIODE	IC411	POWER FACTOR CONTROLLER	MC	COMPRESSOR	X65	RELAY
F1	FUSE (T6.3AL 250V)	IC801	POWER MODULE	MF	FAN MOTOR	X712	RELAY
F2	FUSE (T6.3AL 250V)	IC801	POWER DEVICE	PTC1, 2	CIRCUIT PROTECTION	X714	RELAY
F711	FUSE (T3.15AL 250V)	L	REACTOR	RT61	DEFROST THERMISTOR	X714	RELAY
HPS	HIGH PRESSURE SWITCH	LED1-3	LED	RT62	DISCHARGE TEMP.THERMISTOR	21S4	SOLENOID COIL
				TB1-6	TERMINAL BLOCK		

MXZ-2E53VAHZ - E1

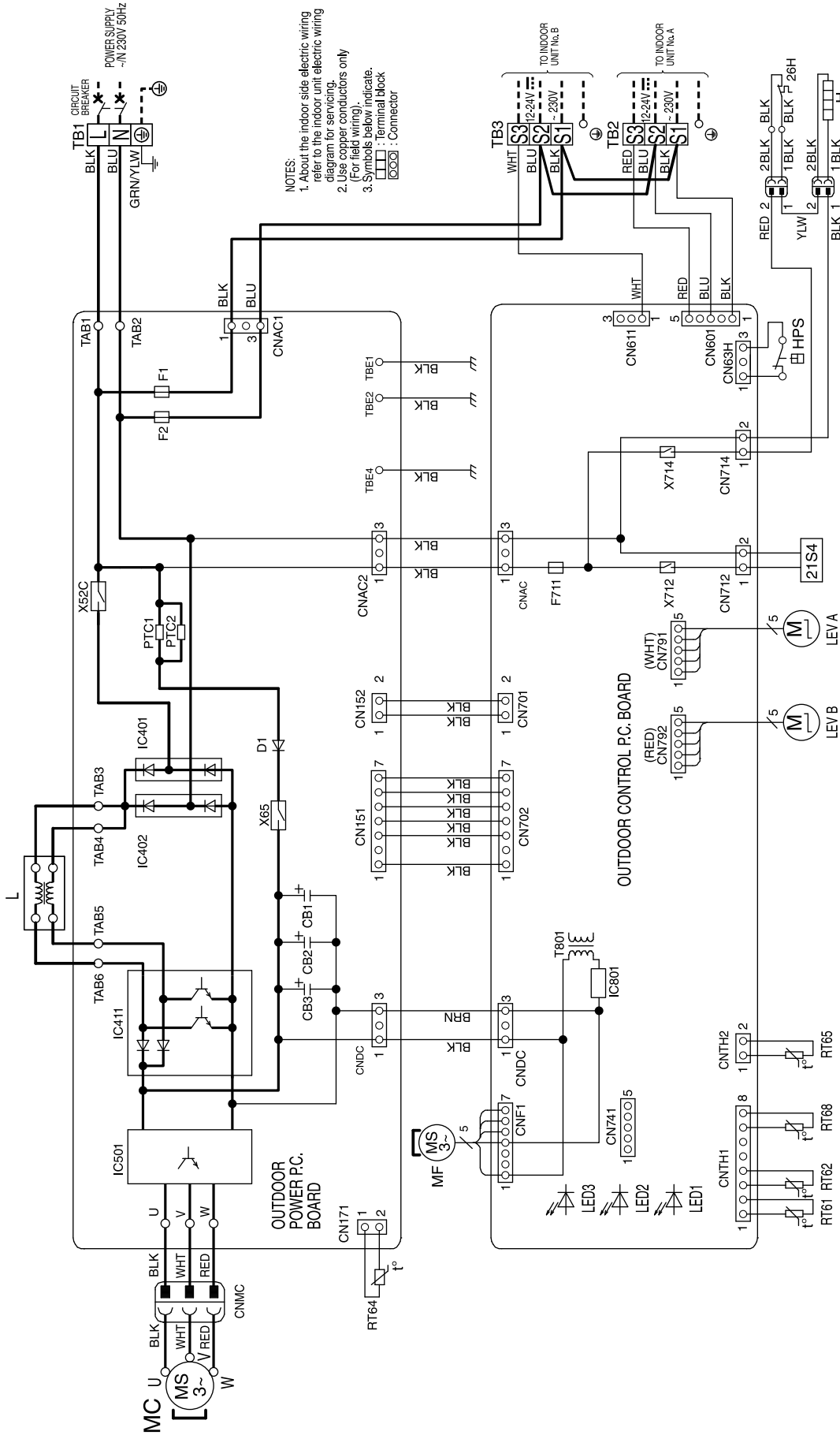

SYMBOL	NAME	SYMBOL	NAME	SYMBOL	NAME	SYMBOL	NAME
CB1-3	SMOOTHING CAPACITOR	HPS	HIGH PRESSURE SWITCH	LED1-3	LED	TB1-3	TERMINAL BLOCK
D1	DIODE	IC401, 402	DIODE BRIDGE	LEV A, B	EXPANSION VALVE COIL	X65C	REVERSING VALVE SOLENOID COIL
F1	FUSE (16.3AL 250V)	IC411	POWER FACTOR CONTROLLER	MC	COMPRESSOR	X65	RELAY
F2	FUSE (16.3AL 250V)	IC501	POWER MODULE	MF	FAN MOTOR	X712	RELAY
F711	FUSE (3.15AL 250V)	IC801	POWER DEVICE	PTC1, 2	CIRCUIT PROTECTION	X714	RELAY
H	DEFROST HEATER	L	REACTOR	RT61	DEFROST THERMISTOR		
				RT62	DISCHARGE TEMP. THERMISTOR		
				RT64	FIN TEMP. THERMISTOR		
				RT65	AMBIENT TEMP. THERMISTOR		
				RT68	OUTDOOR HEAT EXCHANGER TEMPERATURE THERMISTOR		
				T801	TRANSFORMER		

MXZ-2E53VAHZ -ER1

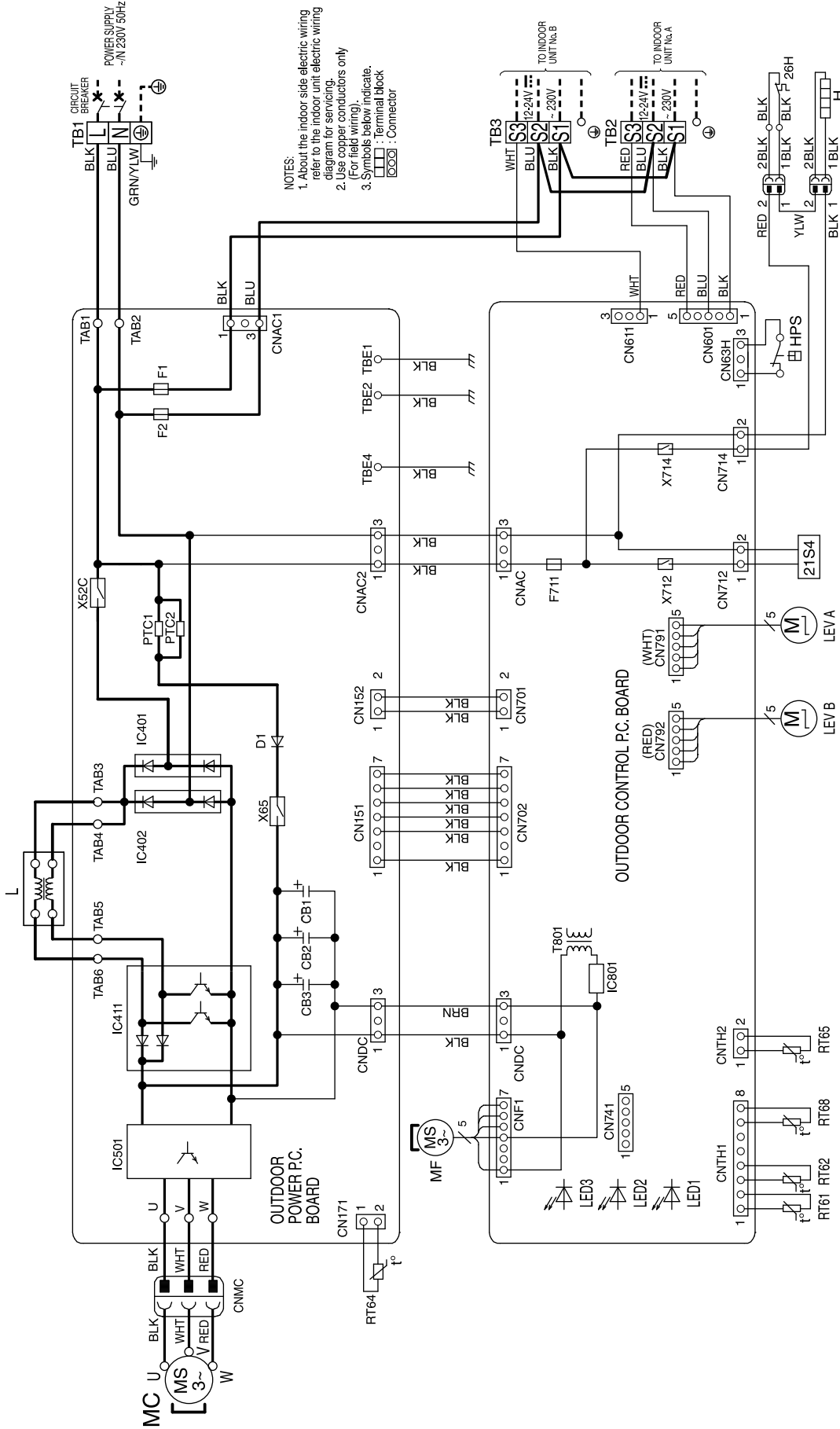

SYMBOL	NAME	SYMBOL	NAME	SYMBOL	NAME	SYMBOL	NAME
CB1-3	SMOOTHING CAPACITOR	HPS	HIGH PRESSURE SWITCH	LED1-3	LED	TB1-3	TERMINAL BLOCK
D1	DIODE	IC401, 402	DIODE BRIDGE	LEV A, B	EXPANSION VALVE COIL	X52C	REVERSING VALVE SOLENOID COIL
F1	FUSE (T6.3AL 250V)	IC411	POWER FACTOR CONTROLLER	MC	COMPRESSOR	X65	RELAY
F2	FUSE (T6.3AL 250V)	IC501	POWER MODULE	MF	FAN MOTOR	X712	RELAY
F711	FUSE (T3.15AL 250V)	IC801	POWER DEVICE	PTC1, 2	CIRCUIT PROTECTION REACTOR	X714	RELAY
H	DEFROST HEATER	L	REACTOR	RT61	DEFROST THERMISTOR	X714	RELAY
				RT62	DISCHARGE TEMP. THERMISTOR	21S4	RELAY
				RT64	FIN TEMP. THERMISTOR	X55C	RELAY
				RT65	AMBIENT TEMP. THERMISTOR	X65	RELAY
				RT68	OUTDOOR HEAT EXCHANGER TEMPERATURE THERMISTOR	X712	RELAY
				T801	TRANSFORMER	X714	RELAY

MXZ-4E83VAHZ - E1

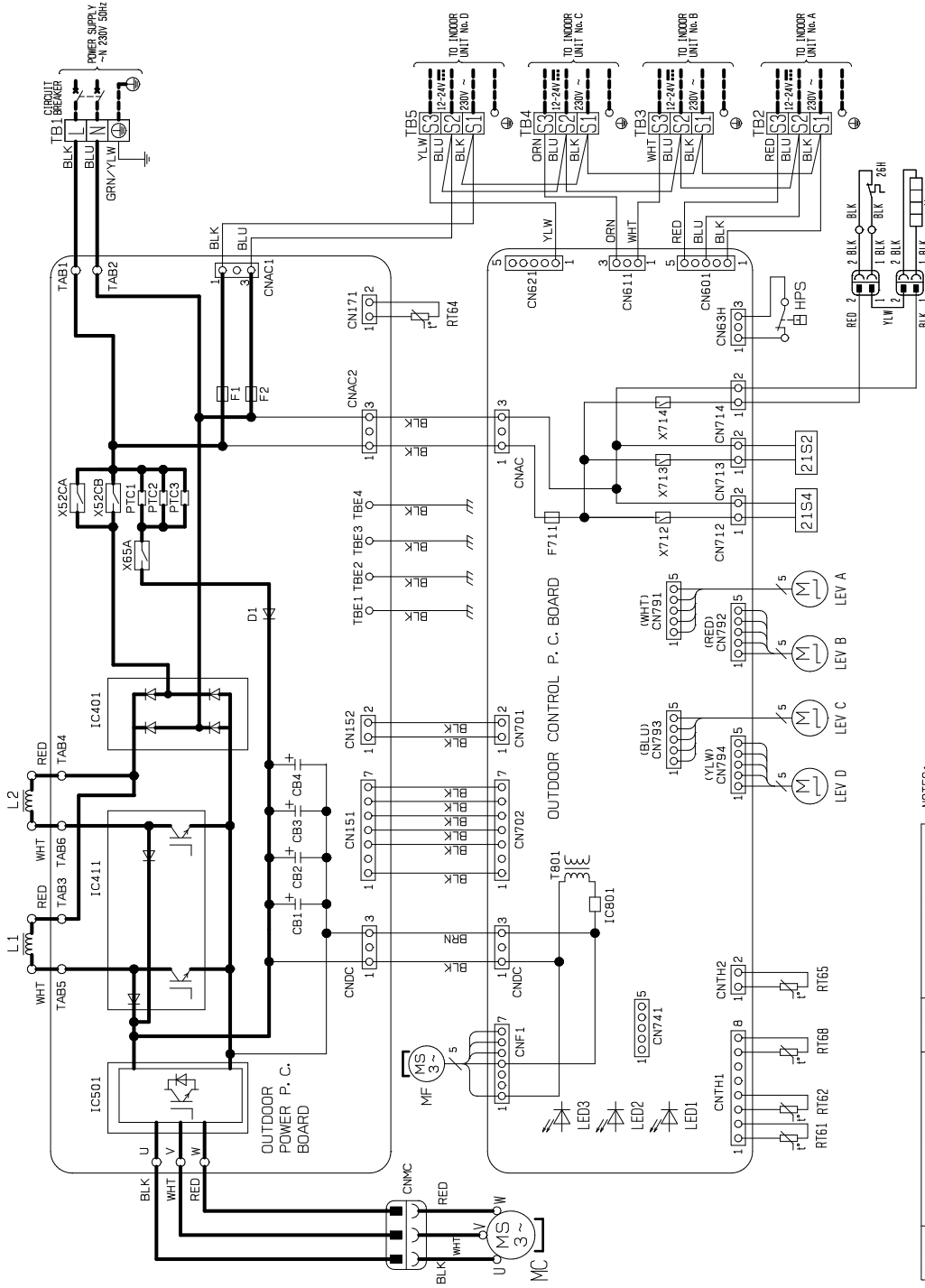

- NOTES:**
1. About the indoor side electric wiring refer to the indoor unit electric wiring diagram for servicing.
 2. Use copper conductors only (For field wiring).
 3. Symbols below indicate.
 - : terminal block
 - : connector

SYMBOL	NAME	SYMBOL	NAME
CB1~4	SMOOTHING CAPACITOR	RT61	DEFROST THERMISTOR
D1	DIODE	RT62	DISCHARGE TEMP. THERMISTOR
F1, F2	FUSE (16. 3AL250V)	RT64	FIN TEMP. THERMISTOR
F711	FUSE (13. 15AL250V)	RT65	AMBIENT TEMP. THERMISTOR
H	DEFROST HEATER	RT68	OUTDOOR HEAT EXCHANGER TEMPERATURE THERMISTOR
HPS	HIGH PRESSURE SWITCH	T801	TRANSFORMER
IC401	DIODE BRIDGE	TB1~5	TERMINAL BLOCK
IC411	POWER MODULE	X52CA,B	RELAY
IC501	POWER MODULE	X65A	RELAY
IC801	POWER DEVICE	X712	RELAY
L1, L2	REACTOR	X713	RELAY
LED 1~3	LED	X714	RELAY
MC	COMPRESSOR	21S2	2WAY VALVE SOLENOID COIL
MF	FAN MOTOR	21S4	REVERSING VALVE SOLENOID COIL
PTC1~3	CIRCUIT PROTECTION	26H	HEATER PROTECTOR

MXZ-4E83VAHZ - E2

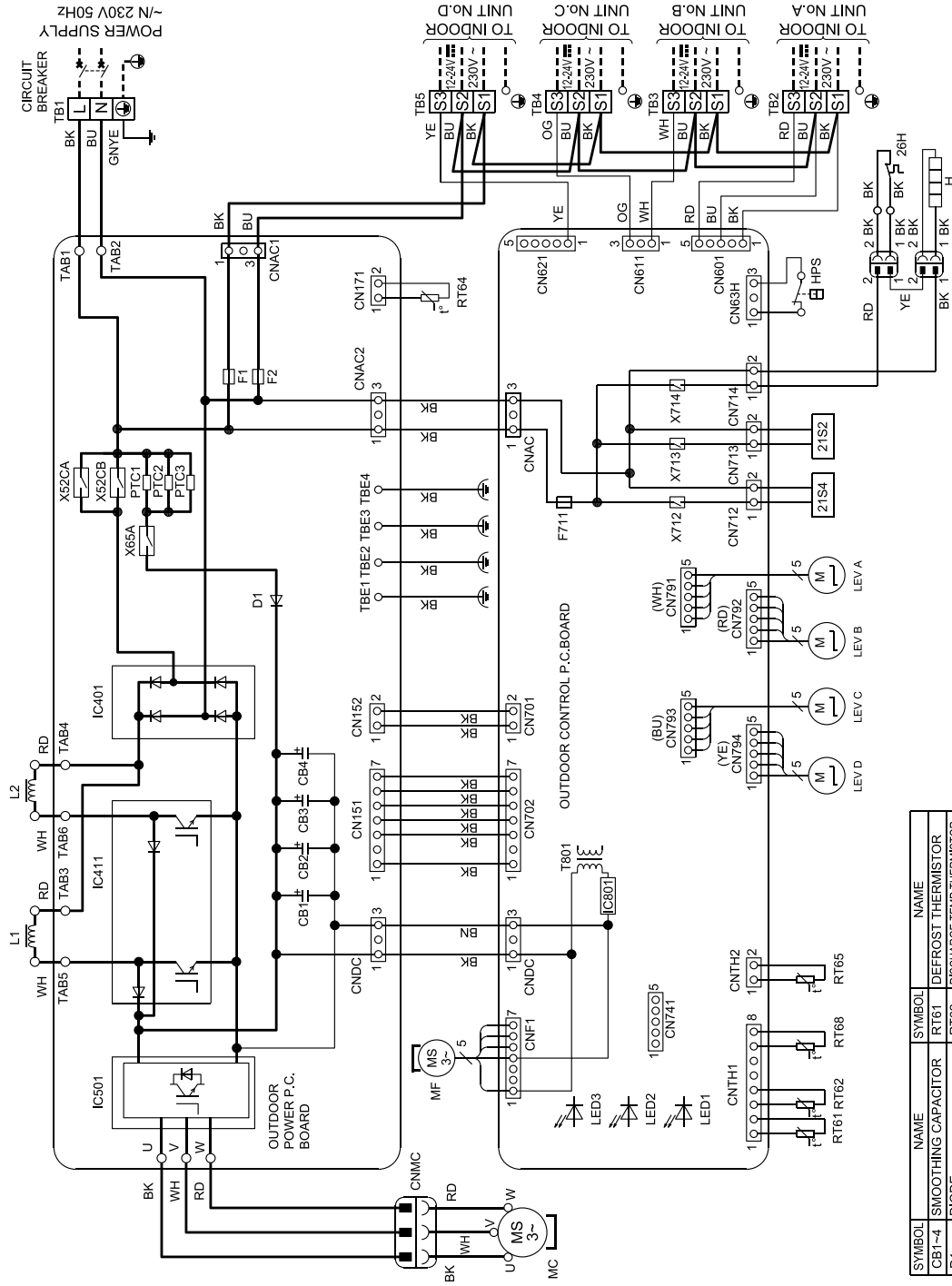

- NOTES:**
1. About the indoor side electric wiring refer to the indoor unit electric wiring diagram for servicing.
 2. Use copper conductors only (For field wiring).
 3. Symbols below indicate.
 - : Terminal block
 - : Relay
 - : Diode
 - : Capacitor
 - : Resistor
 - : Coil
 - : Motor
 - : LED
 - : Transformer
 - : Fuse
 - : Circuit breaker
 - : Switch
 - : Connector

SYMBOL	NAME	SYMBOL	NAME
CB1-4	SMOOTHING CAPACITOR	RT61	DEFROST THERMISTOR
D1	DIODE	RT62	DISCHARGE TEMP.THERMISTOR
F1,F2	FUSE(T6.3AL250V)	RT64	FIN TEMP.THERMISTOR
F711	FUSE(T3.15AL250V)	RT65	AMBIENT TEMP.THERMISTOR
H	DEFROST HEATER	RT68	OUTDOOR HEAT EXCHANGER
HPS	HIGH PRESSURE SWITCH		TEMPERATURE THERMISTOR
IC401	DIODE BRIDGE	T801	TRANSFORMER
IC411	POWER MODULE	TB1-5	TERMINAL BLOCK
IC501	POWER MODULE	X52CA,B	RELAY
IC801	POWER DEVICE	X65A	RELAY
L1,L2	REACTOR	X712	RELAY
LED1-3	LED	X713	RELAY
LEV A-D	EXPANSION VALVE COIL	X714	RELAY
MC	COMPRESSOR	Z1S2	2WAY VALVE SOLENOID COIL
MF	FAN MOTOR	Z1S4	REVERSING VALVE SOLENOID COIL
PTC1-3	CIRCUIT PROTECTION	26H	HEATER PROTECTOR

MXZ-4E83VAHZ -ER1

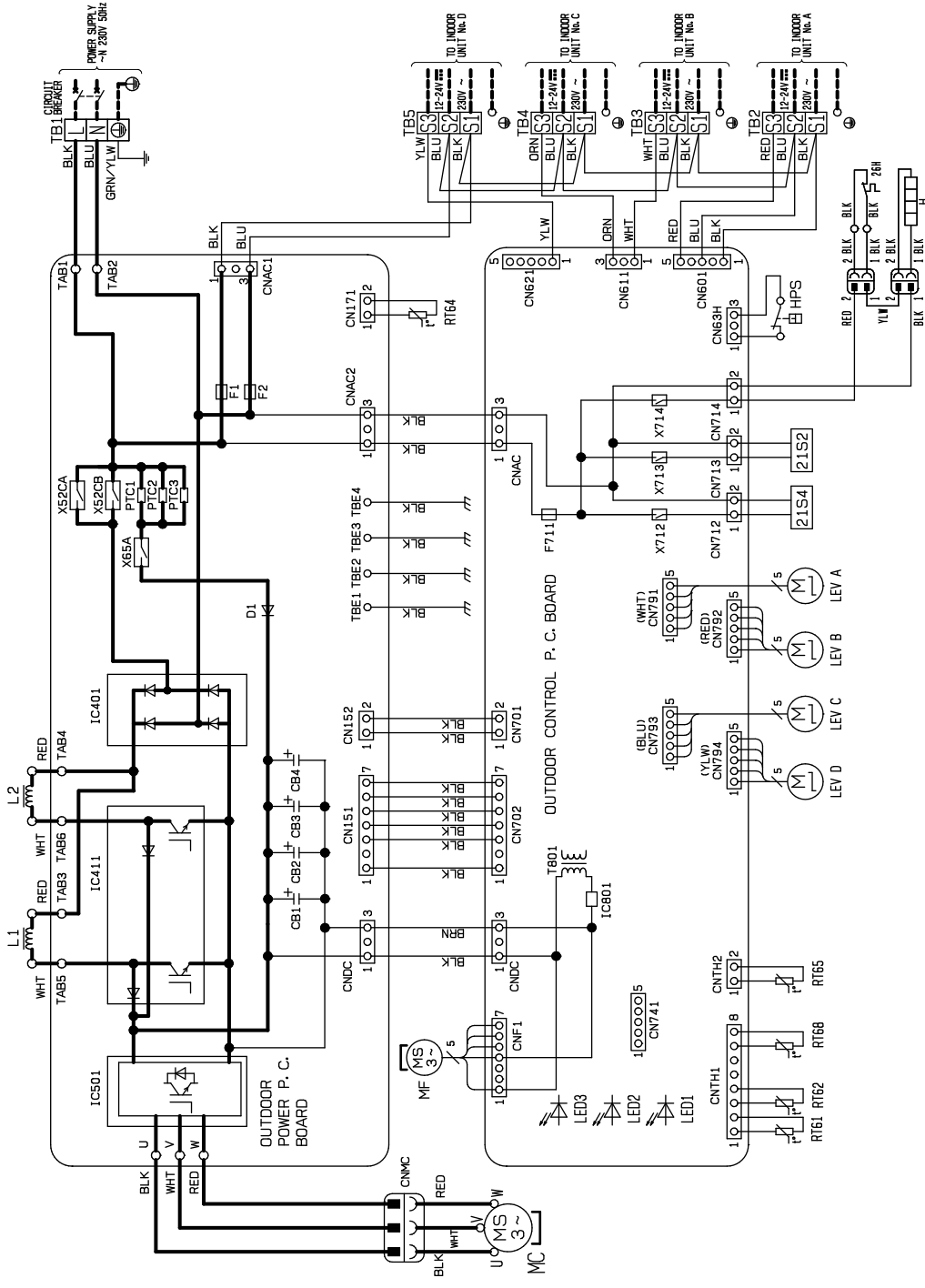

- NOTES:
1. About the indoor side electric wiring refer to the indoor unit electric wiring diagram for servicing.
 2. Use copper conductors only (For field wiring).
 3. Symbols below indicate.
 □ : terminal block
 ○ : connector

SYMBOL	NAME	SYMBOL	NAME
CB1~4	SMOOTHING CAPACITOR	RT61	DEFROST THERMISTOR
D1	DIODE	RT62	DISCHARGE TEMP. THERMISTOR
F.1, F2	FUSE (T6, 3AL250V)	RT64	FIN TEMP. THERMISTOR
F711	FUSE (T3, 15AL250V)	RT65	AMBIENT TEMP. THERMISTOR
H	DEFROST HEATER	RT68	OUTDOOR HEAT EXCHANGER TEMPERATURE THERMISTOR
HPS	HIGH PRESSURE SWITCH	T801	TRANSFORMER
IC401	DIODE BRIDGE	TB1~S	TERMINAL BLOCK
IC411	POWER MODULE	X52CA, B	RELAY
IC801	POWER MODULE	X65A	RELAY
L1, L2	REACTOR	X712	RELAY
LED 1~3	LED	X713	RELAY
LEV A~D	EXPANSION VALVE	X714	RELAY
MC	COMPRESSOR	21S2	2WAY VALVE SOLENOID COIL
MF	FAN MOTOR	21S4	REVERSING VALVE SOLENOID COIL
PTCT~3	CIRCUIT PROTECTION	26H	HEATER PROTECTOR

MXZ-4E83VAHZ - ER2

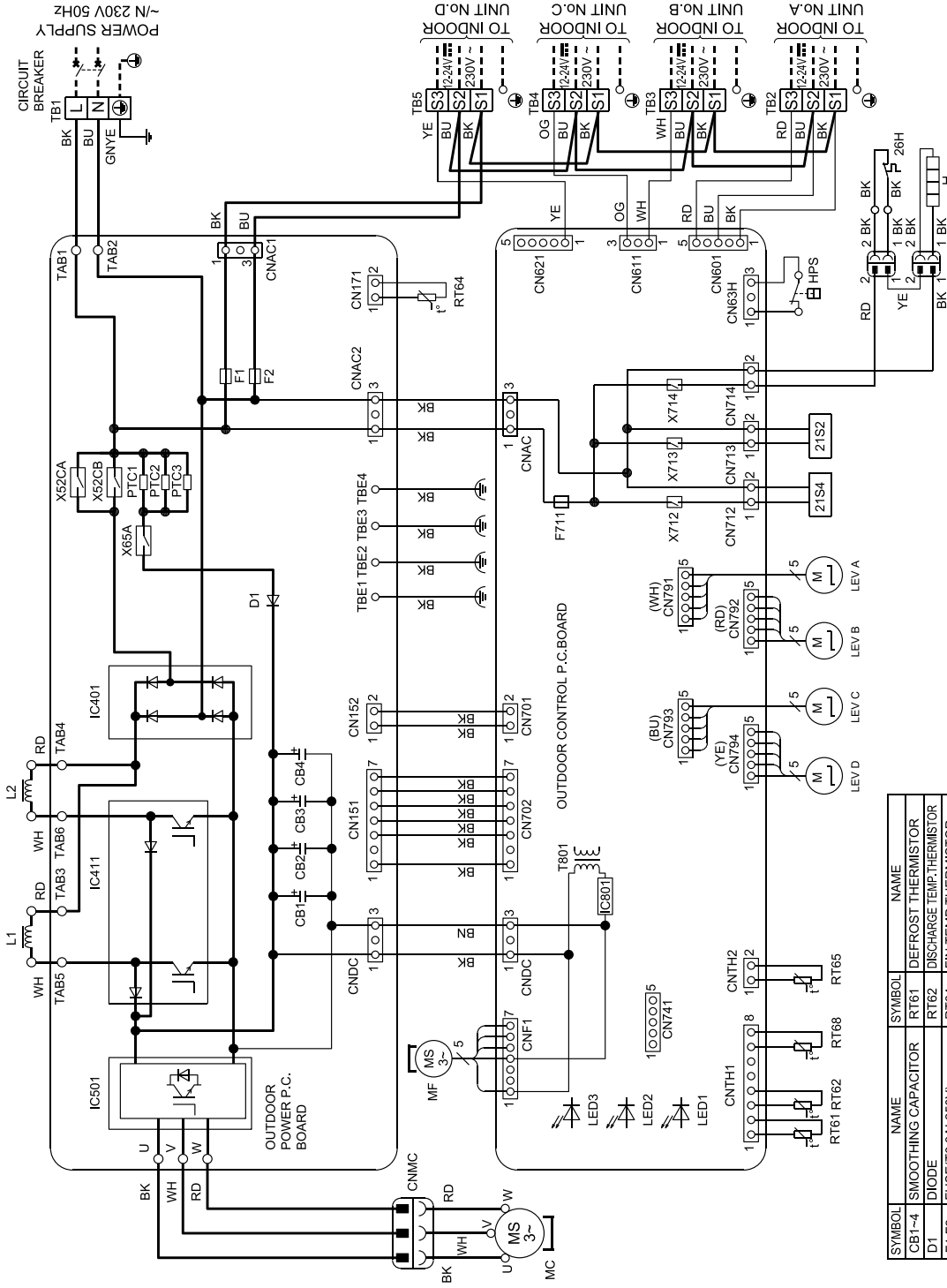

- NOTES:
1. About the indoor side electric wiring refer to the indoor unit electric wiring diagram for servicing.
 2. Use copper conductors only (For field wiring).
 3. Symbols below indicate.
 - □ □ □ : Terminal block
 - □ □ □ : Connector

SYMBOL	NAME	SYMBOL	NAME
CB1~4	SMOOTHING CAPACITOR	RT61	DEFROST THERMISTOR
D1	DIODE	RT62	DISCHARGE TEMP.THERMISTOR
F1,F2	FUSE(T6.3AL250V)	RT64	FIN TEMP.THERMISTOR
F711	FUSE(T3.15AL250V)	RT65	AMBIENT TEMP.THERMISTOR
H	DEFROST HEATER	RT68	OUTDOOR HEAT EXCHANGER TEMPERATURE THERMISTOR
HPS	HIGH PRESSURE SWITCH	T801	TRANSFORMER
IC401	DIODE BRIDGE	TB1~5	TERMINAL BLOCK
IC411	POWER MODULE	X52CA,B	RELAY
IC501	POWER MODULE	X65A	RELAY
IC801	POWER DEVICE	X712	RELAY
L1,L2	REACTOR	X713	RELAY
LED1~3	LED	X714	RELAY
LEV A-D	EXPANSION VALVE COIL	21S2	2WAY VALVE SOLENOID COIL
MC	COMPRESSOR	21S4	REVERSING VALVE SOLENOID COIL
MF	FAN MOTOR	26H	HEATER PROTECTOR
PTC1~3	CIRCUIT PROTECTION		

MXZ-3E54VA

UNIT: mm

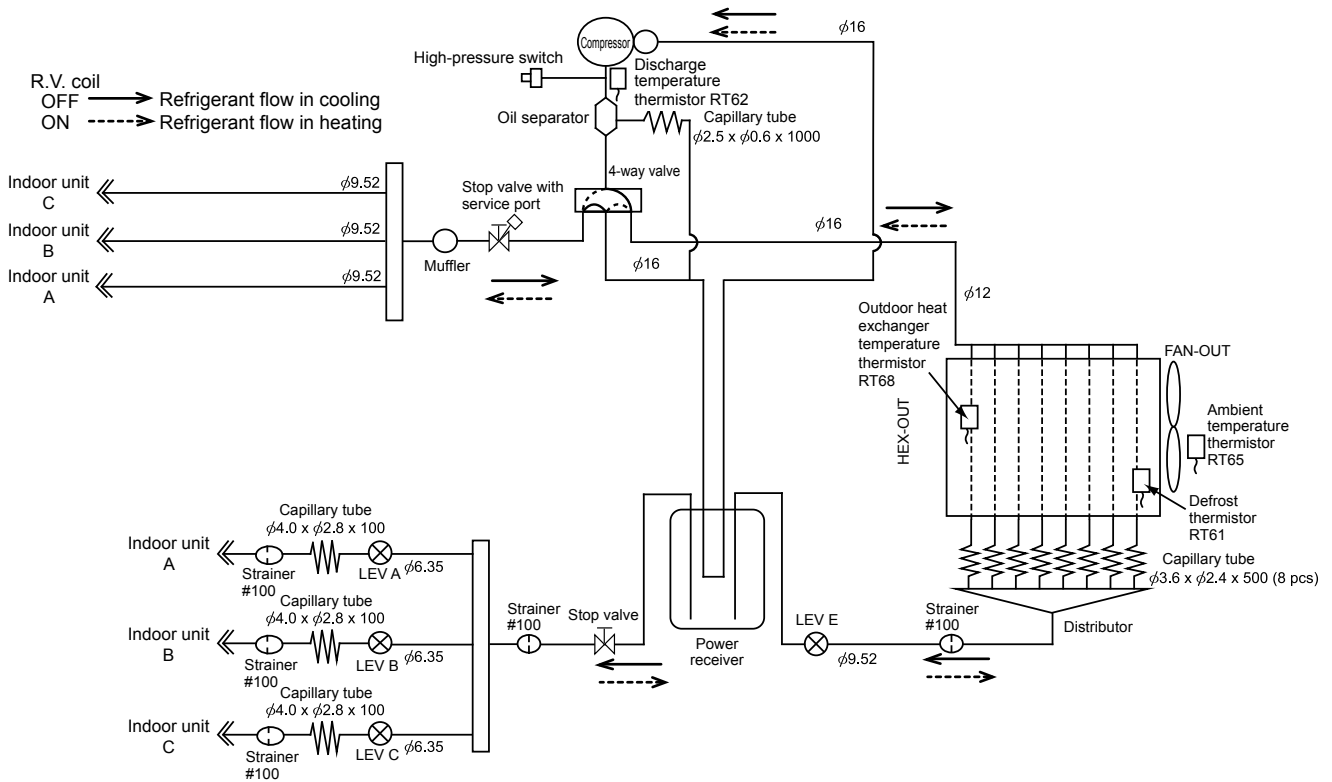

MAX REFRIGERANT PIPING LENGTH

Piping length each indoor unit (a, b, c)	25 m
Total piping length (a+b+c)	50 m
Bending point for each unit	25
Total bending point	50

*It is irrelevant which unit is higher.

ADDITIONAL REFRIGERANT CHARGE

Outdoor unit precharged (g)	Refrigerant piping length (one way, 3 unit total)		
	40 m	45 m	50 m
2,700	0	100	200

Calculation : $Xg = 20 \text{ g/m} \times (\text{Refrigerant piping length (m)} - 40)$ WHEN CONNECTING TO MFZ-KJ SERIES INDOOR UNIT
MXZ-3E54VA

No. of MFZ-KJ indoor units	Refrigerant piping length (L)		Maximum amount of refrigerant
	~ 40 m	~ 50 m	
None	Charge-less (2,700 g)	$(L-40) \times 20 \text{ g/m}$	2,900 g
1 unit	100 g additional charge (2,800 g)	$100 \text{ g} + (L-40) \times 20 \text{ g/m}$	3,000 g
2 units	200 g additional charge (2,900 g)	$200 \text{ g} + (L-40) \times 20 \text{ g/m}$	3,100 g
3 units	300 g additional charge (3,000 g)	$300 \text{ g} + (L-40) \times 20 \text{ g/m}$	3,200 g

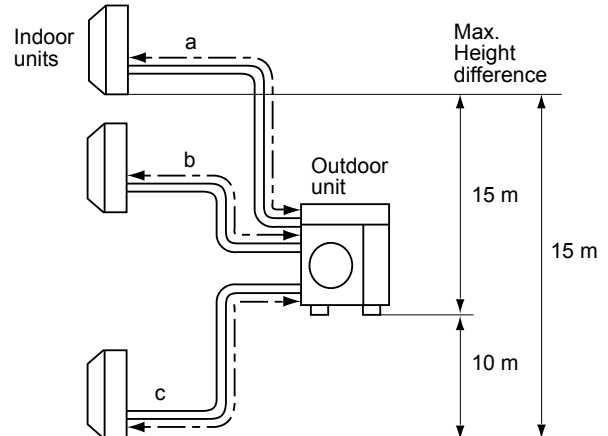

UNIT: mm (inch)

- Refrigerant pipe diameter is different according to indoor unit to be connected. When using extension pipes, refer to the right table.
 - When diameter of refrigerant pipe is different from that of outdoor unit union, use optional Different-diameter pipe.
- For further information on Different-diameter pipe, refer to "PARTS CATALOG".

Outdoor unit union diameter		
For		
Indoor unit A	Liquid	6.35(1/4)
	Gas	9.52(3/8)
Indoor unit B	Liquid	6.35(1/4)
	Gas	9.52(3/8)
Indoor unit C	Liquid	6.35(1/4)
	Gas	9.52(3/8)

MXZ-3E68VA

UNIT: mm

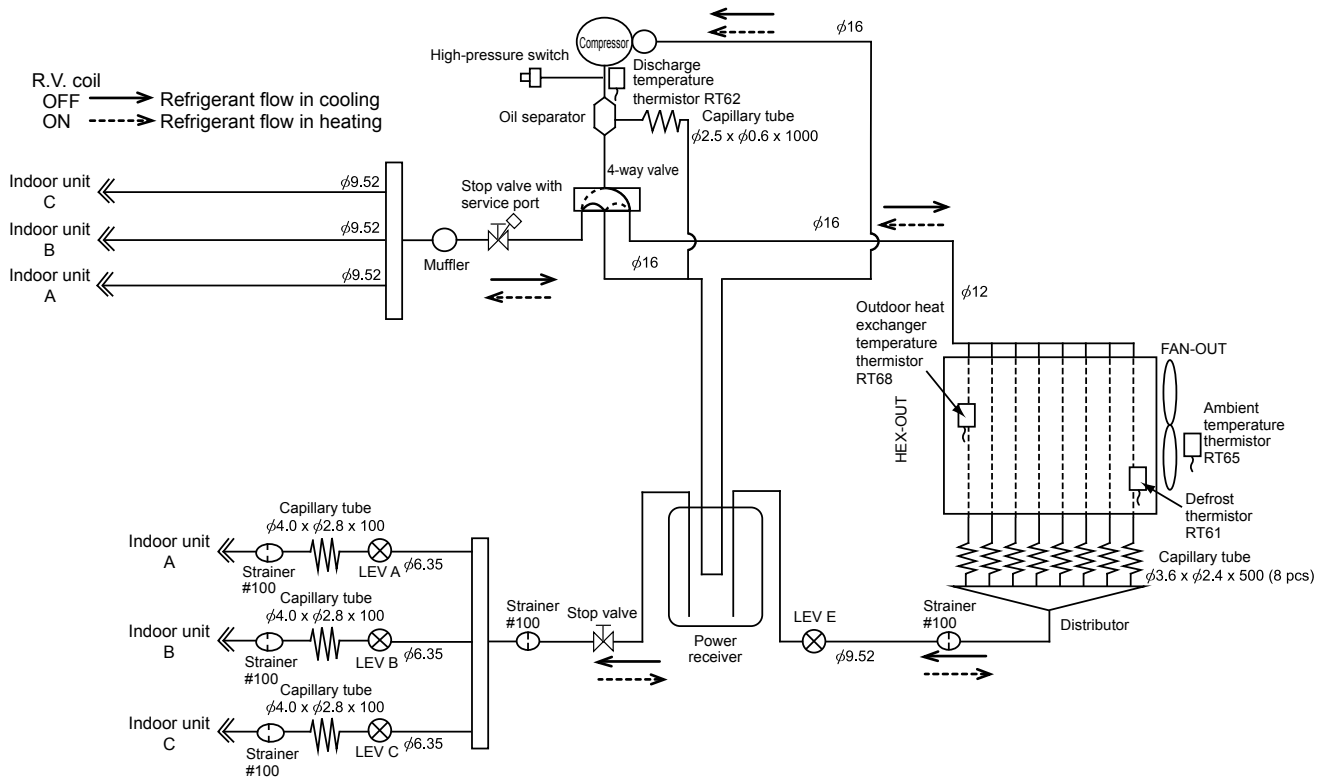

MAX REFRIGERANT PIPING LENGTH

Piping length each indoor unit (a, b, c)	25 m
Total piping length (a+b+c)	60 m
Bending point for each unit	25
Total bending point	60

*It is irrelevant which unit is higher.

ADDITIONAL REFRIGERANT CHARGE

Outdoor unit precharged (g)	Refrigerant piping length (one way, 3 unit total)		
	40 m	50 m	60 m
2,700	0	200	400

Calculation : $Xg = 20 \text{ g/m} \times (\text{Refrigerant piping length (m)} - 40)$

WHEN CONNECTING TO MFZ-KJ SERIES INDOOR UNIT MXZ-3E68VA

No. of MFZ-KJ indoor units	Refrigerant piping length (L)		Maximum amount of refrigerant
	~ 40 m	~ 60 m	
None	Charge-less (2,700 g)	$(L-40) \times 20 \text{ g/m}$	3,100 g
1 unit	100 g additional charge (2,800 g)	$100 \text{ g} + (L-40) \times 20 \text{ g/m}$	3,200 g
2 units	200 g additional charge (2,900 g)	$200 \text{ g} + (L-40) \times 20 \text{ g/m}$	3,300 g
3 units	300 g additional charge (3,000 g)	$300 \text{ g} + (L-40) \times 20 \text{ g/m}$	3,400 g

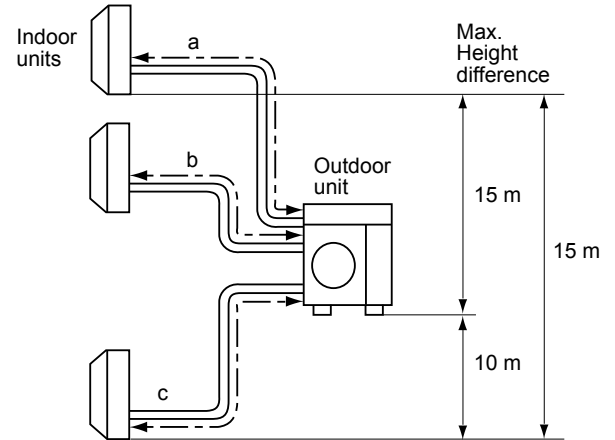

UNIT: mm (inch)

- Refrigerant pipe diameter is different according to indoor unit to be connected. When using extension pipes, refer to the right table.
 - When diameter of refrigerant pipe is different from that of outdoor unit union, use optional Different-diameter pipe.
- For further information on Different-diameter pipe, refer to "PARTS CATALOG".

Outdoor unit union diameter		
For		
Indoor unit A	Liquid	6.35(1/4)
	Gas	9.52(3/8)
Indoor unit B	Liquid	6.35(1/4)
	Gas	9.52(3/8)
Indoor unit C	Liquid	6.35(1/4)
	Gas	9.52(3/8)

MXZ-4E72VA

UNIT: mm

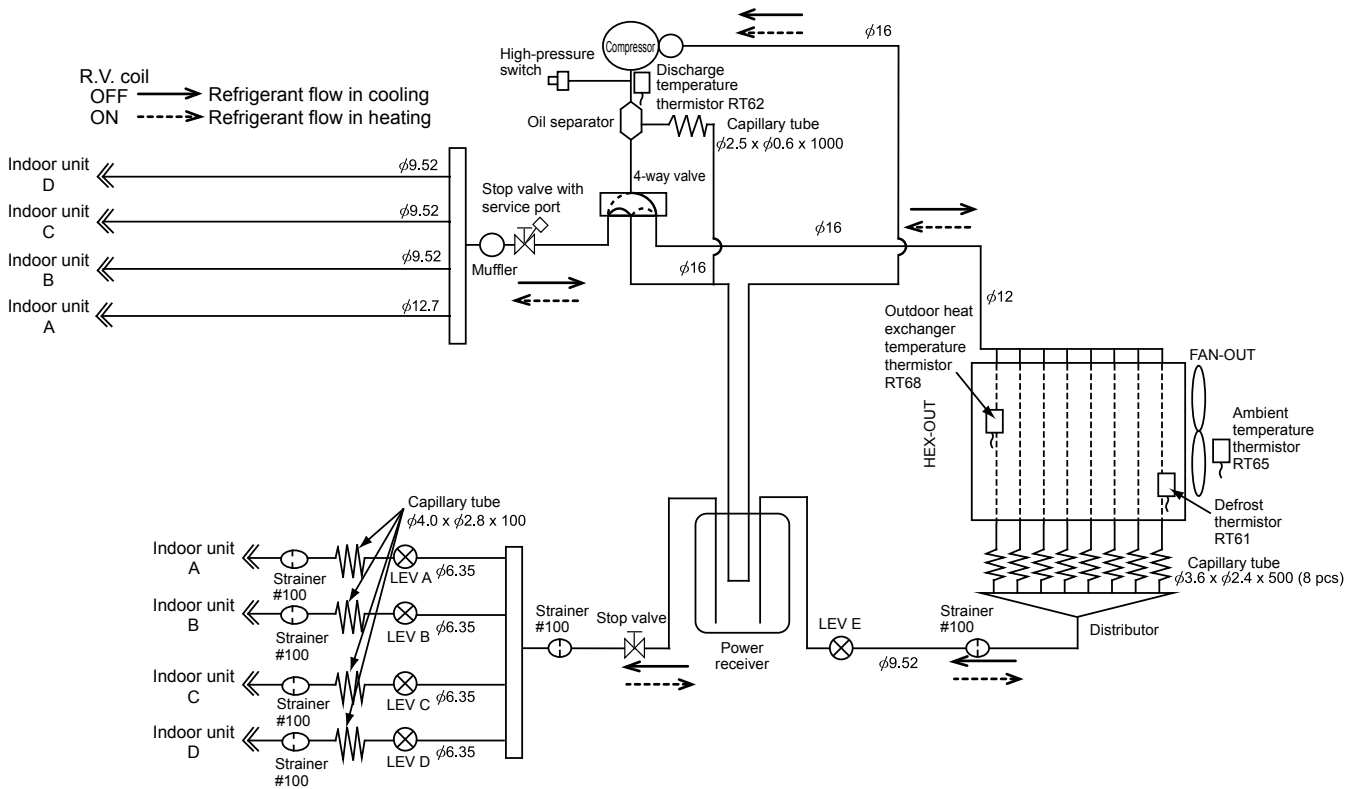

MAX REFRIGERANT PIPING LENGTH

Piping length each indoor unit (a, b, c, d)	25 m
Total piping length (a+b+c+d)	60 m
Bending point for each unit	25
Total bending point	60

*It is irrelevant which unit is higher.

ADDITIONAL REFRIGERANT CHARGE

Outdoor unit precharged (g)	Refrigerant piping length (one way, 4 unit total)		
	40 m	50 m	60 m
2,700	0	200	400

Calculation : $Xg = 20 \text{ g/m} \times (\text{Refrigerant piping length (m)} - 40)$

WHEN CONNECTING TO MFZ-KJ SERIES INDOOR UNIT MXZ-4E72VA

No. of MFZ-KJ indoor units	Refrigerant piping length (L)		Maximum amount of refrigerant
	~ 40 m	~ 60 m	
None	Charge-less (2,700 g)	$(L-40) \times 20 \text{ g/m}$	3,100 g
1 unit	100 g additional charge (2,800 g)	$100 \text{ g} + (L-40) \times 20 \text{ g/m}$	3,200 g
2 units	200 g additional charge (2,900 g)	$200 \text{ g} + (L-40) \times 20 \text{ g/m}$	3,300 g
3 units	300 g additional charge (3,000 g)	$300 \text{ g} + (L-40) \times 20 \text{ g/m}$	3,400 g
4 units	400 g additional charge (3,100 g)	$400 \text{ g} + (L-40) \times 20 \text{ g/m}$	3,500 g

UNIT: mm (inch)

- Refrigerant pipe diameter is different according to indoor unit to be connected. When using extension pipes, refer to the right table.
- When diameter of refrigerant pipe is different from that of outdoor unit union, use optional Different-diameter pipe. For further information on Different-diameter pipe, refer to "PARTS CATALOG".

Outdoor unit union diameter		
For		
Indoor unit A	Liquid	6.35(1/4)
	Gas	12.7(1/2)
Indoor unit B	Liquid	6.35(1/4)
	Gas	9.52(3/8)
Indoor unit C	Liquid	6.35(1/4)
	Gas	9.52(3/8)
Indoor unit D	Liquid	6.35(1/4)
	Gas	9.52(3/8)

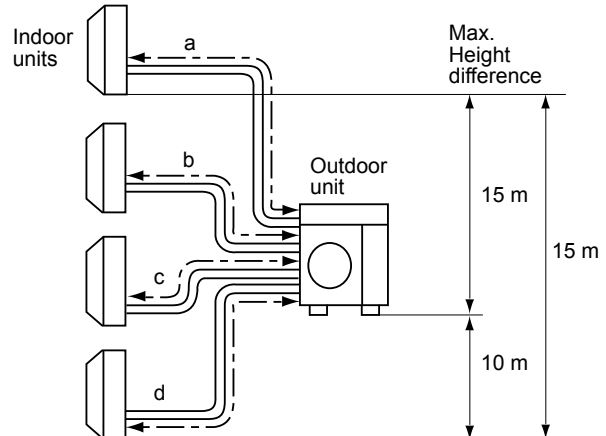

MXZ-4E83VA

UNIT: mm

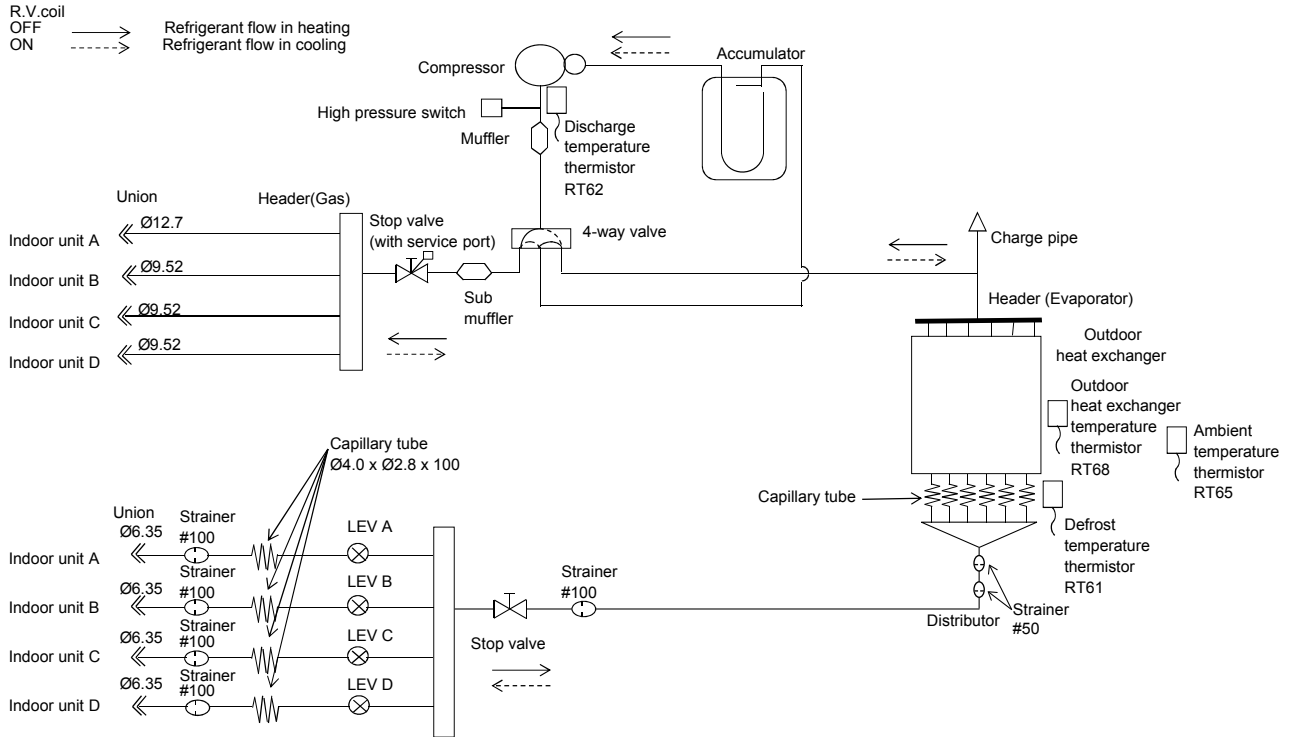

MAX REFRIGERANT PIPING LENGTH

Piping length each indoor unit (a, b, c, d)	25 m
Total piping length (a+b+c+d)	70 m
Bending point for each unit	25
Total bending point	70

*It is irrelevant which unit is higher.

ADDITIONAL REFRIGERANT CHARGE

Outdoor unit precharged (g)	Refrigerant piping length (one way, 4 unit total)			
	25 m	40 m	55 m	70 m
2,990	0	300	600	900

Calculation : $Xg = 20 \text{ g/m} \times (\text{Refrigerant piping length (m)} - 25)$

- Refrigerant pipe diameter is different according to indoor unit to be connected. When using extension pipes, refer to the tables below.
- When diameter of refrigerant pipe is different from that of outdoor unit union, use optional Different-diameter pipe. For further information on Different-diameter pipe, refer to "PARTS CATALOG".

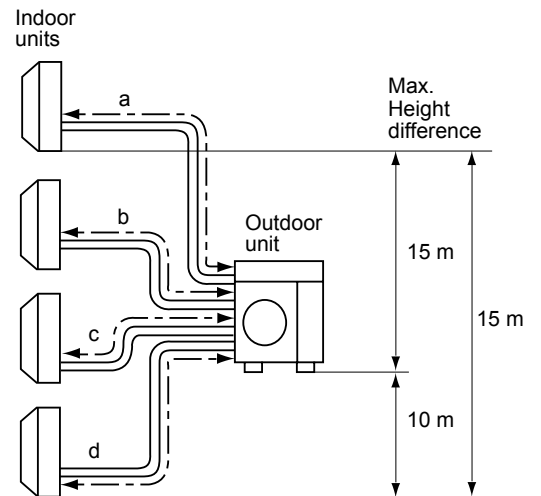

UNIT: mm (inch)

Outdoor unit union diameter		
For		
Indoor unit A	Liquid	6.35(1/4)
	Gas	12.7(1/2)
Indoor unit B	Liquid	6.35(1/4)
	Gas	9.52(3/8)
Indoor unit C	Liquid	6.35(1/4)
	Gas	9.52(3/8)
Indoor unit D	Liquid	6.35(1/4)
	Gas	9.52(3/8)

MXZ-5E102VA

UNIT: mm

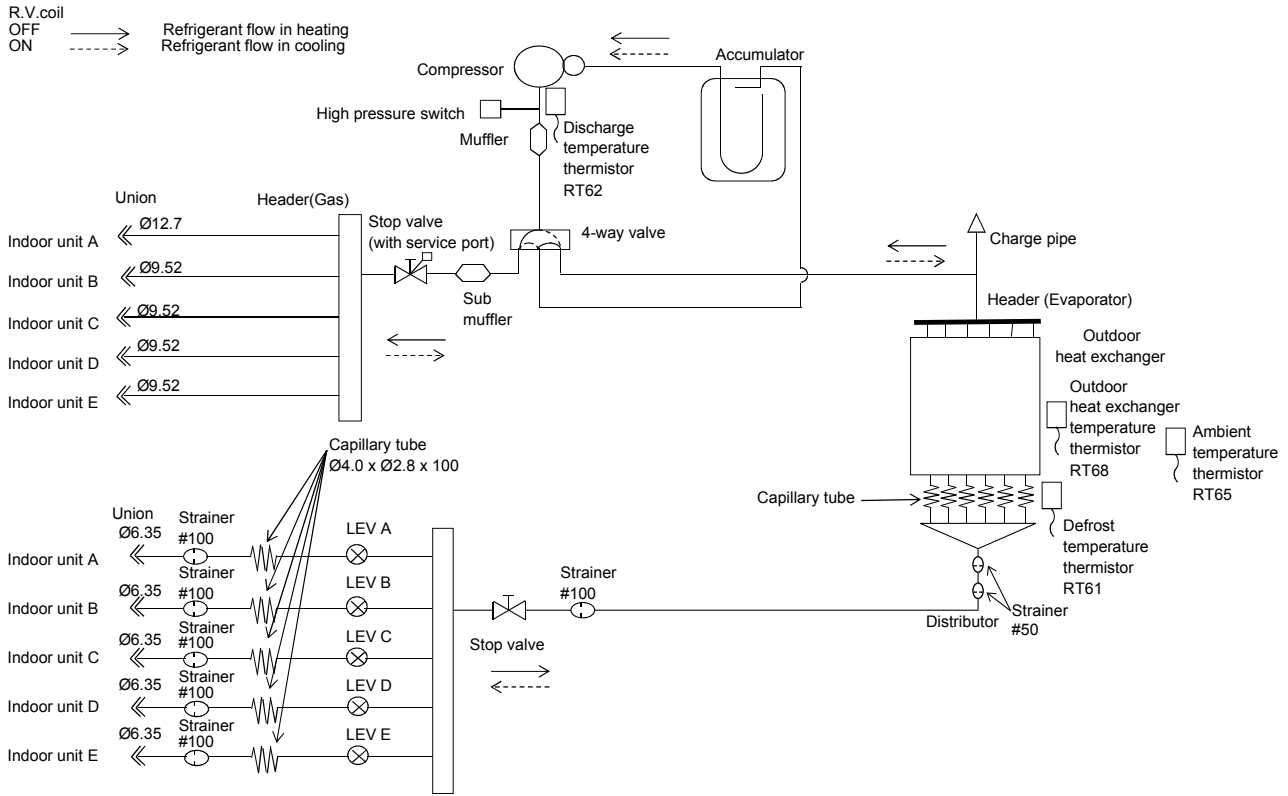

MAX REFRIGERANT PIPING LENGTH

Piping length each indoor unit (a, b, c, d, e)	25 m
Total piping length (a+b+c+d+e)	80 m
Bending point for each unit	25
Total bending point	80

*It is irrelevant which unit is higher.

ADDITIONAL REFRIGERANT CHARGE

Outdoor unit precharged (g)	Refrigerant piping length (one way, 5 unit total)				
	0 m	20 m	40 m	60 m	80 m
2,990	0	400	800	1,200	1,600

Calculation : $Xg = 20 \text{ g/m} \times (\text{Refrigerant piping length (m)} - 0)$

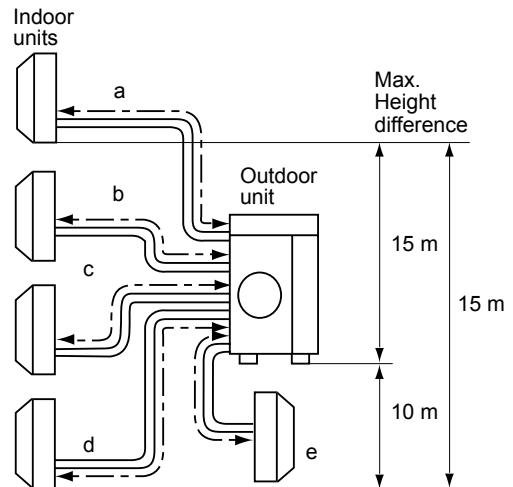

- Refrigerant pipe diameter is different according to indoor unit to be connected. When using extension pipes, refer to the tables below.
- When diameter of refrigerant pipe is different from that of outdoor unit union, use optional Different-diameter pipe. For further information on Different-diameter pipe, refer to "PARTS CATALOG".

UNIT: mm (inch)

Outdoor unit union diameter		
For		
Indoor unit A	Liquid	6.35(1/4)
	Gas	12.7(1/2)
Indoor unit B	Liquid	6.35(1/4)
	Gas	9.52(3/8)
Indoor unit C	Liquid	6.35(1/4)
	Gas	9.52(3/8)
Indoor unit D	Liquid	6.35(1/4)
	Gas	9.52(3/8)
Indoor unit E	Liquid	6.35(1/4)
	Gas	9.52(3/8)



MXZ-2E53VAHZ

UNIT: mm

R.V.coil
 OFF \longrightarrow Refrigerant flow in heating
 ON \dashrightarrow Refrigerant flow in cooling

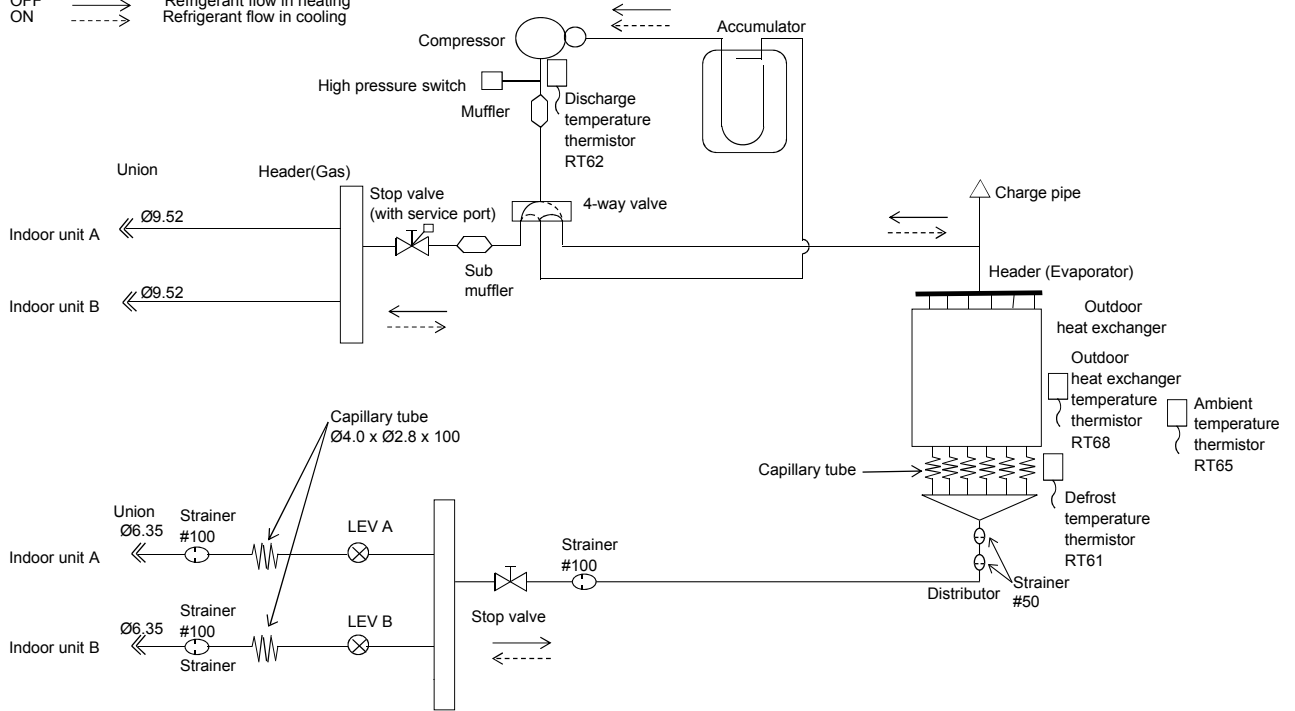

MAX REFRIGERANT PIPING LENGTH

Piping length each indoor unit (a, b)	20 m
Total piping length (a+b)	30 m
Bending point for each unit	20
Total bending point	30

*It is irrelevant which unit is higher.

ADDITIONAL REFRIGERANT CHARGE

Outdoor unit precharged (g)	Refrigerant piping length (one way, 2 unit total)		
	20 m	25 m	30 m
2,000	0	100	200

Calculation : $Xg = 20 \text{ g/m} \times (\text{Refrigerant piping length (m)} - 20)$

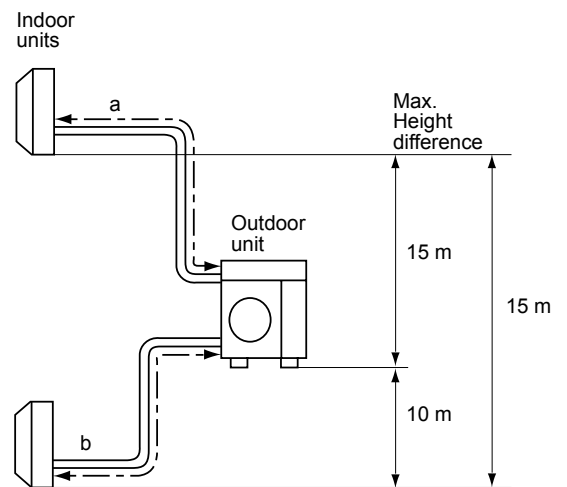

- Refrigerant pipe diameter is different according to indoor unit to be connected. When using extension pipes, refer to the tables below.
- When diameter of refrigerant pipe is different from that of outdoor unit union, use optional Different-diameter pipe. For further information on Different-diameter pipe, refer to "PARTS CATALOG".

UNIT: mm (inch)

Outdoor unit union diameter		
For		
Indoor unit A	Liquid	6.35(1/4)
	Gas	9.52(3/8)
Indoor unit B	Liquid	6.35(1/4)
	Gas	9.52(3/8)

MXZ-4E83VAHZ

UNIT: mm

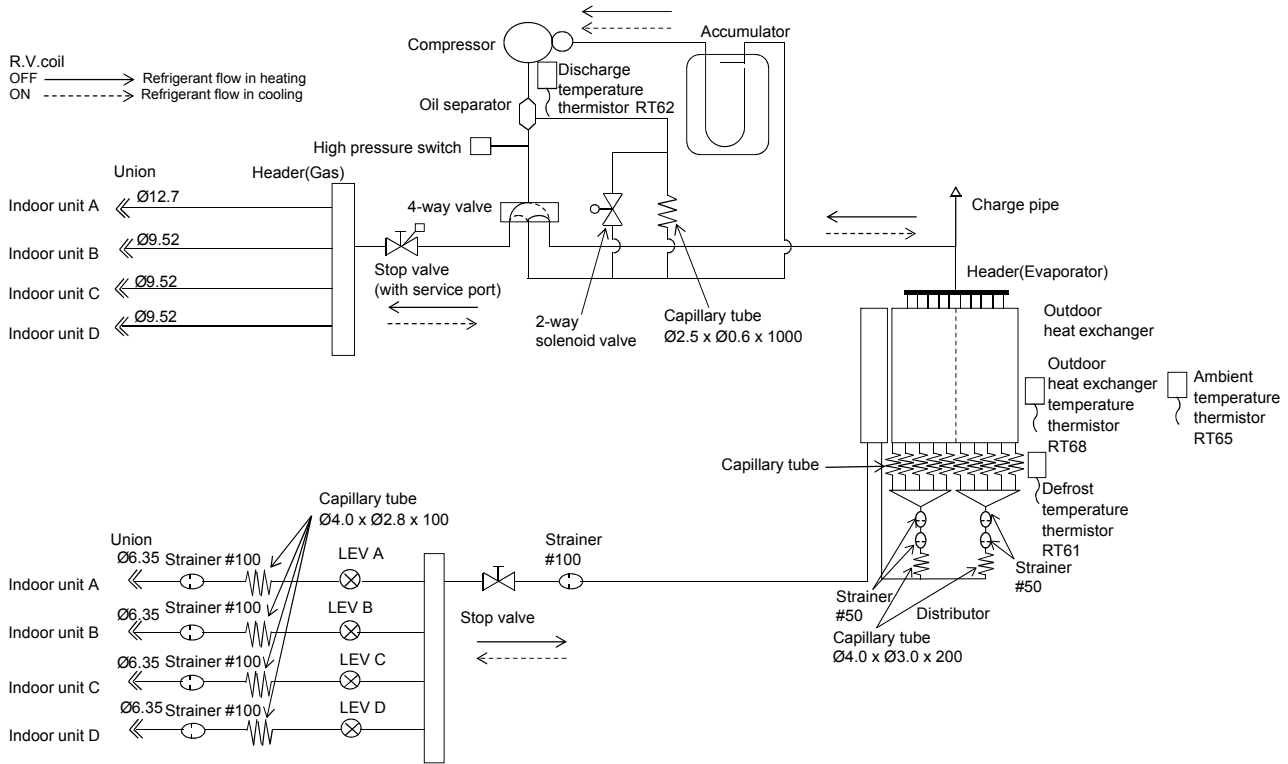

MAX REFRIGERANT PIPING LENGTH

Piping length each indoor unit (a, b, c, d)	25 m
Total piping length (a+b+c+d)	70 m
Bending point for each unit	25
Total bending point	70

*It is irrelevant which unit is higher.

ADDITIONAL REFRIGERANT CHARGE

Outdoor unit precharged (g)	Refrigerant piping length (one way, 4 unit total)			
	25 m	40 m	55 m	70 m
3,900	0	300	600	900

Calculation : $Xg = 20 \text{ g/m} \times (\text{Refrigerant piping length (m)} - 25)$

- Refrigerant pipe diameter is different according to indoor unit to be connected. When using extension pipes, refer to the tables below.
- When diameter of refrigerant pipe is different from that of outdoor unit union, use optional Different-diameter pipe. For further information on Different-diameter pipe, refer to "PARTS CATALOG".

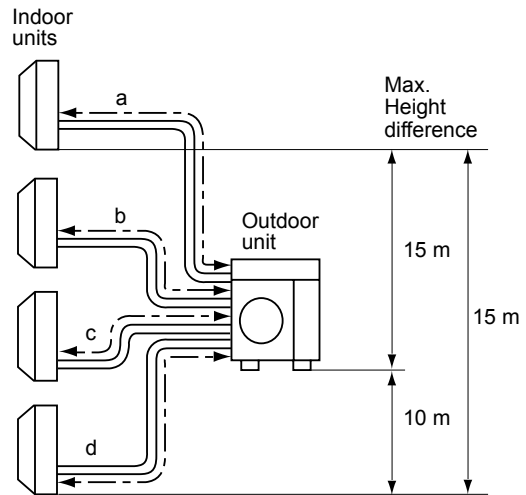

UNIT: mm (inch)

Outdoor unit union diameter		
For		
Indoor unit A	Liquid	6.35(1/4)
	Gas	12.7(1/2)
Indoor unit B	Liquid	6.35(1/4)
	Gas	9.52(3/8)
Indoor unit C	Liquid	6.35(1/4)
	Gas	9.52(3/8)
Indoor unit D	Liquid	6.35(1/4)
	Gas	9.52(3/8)



PUMPING DOWN

When relocating or disposing of the air conditioner, pump down the system following the procedure below so that no refrigerant is released into the atmosphere.

- 1) Turn off the breaker.
- 2) Connect the gauge manifold valve to the service port of the stop valve on the gas pipe side of the outdoor unit.
- 3) Fully close the stop valve on the liquid pipe side of the outdoor unit.
- 4) Turn on the breaker.
- 5) Start the emergency COOL operation on all the indoor units.
- 6) When the pressure gauge shows 0.05 to 0 MPa [Gauge] (approximately 0.5 to 0 kgf/cm²), fully close the stop valve on the gas pipe side of the outdoor unit and stop the operation. (Refer to the indoor unit installation manual about the method for stopping the operation.)
 - * If too much refrigerant has been added to the air conditioner system, the pressure may not drop to 0.05 to 0 MPa [Gauge] (approximately 0.5 to 0 kgf/cm²), or the protection function may operate due to the pressure increase in the high pressure refrigerant circuit. If this occurs, use a refrigerant collecting device to collect all of the refrigerant in the system, and then recharge the system with the correct amount of refrigerant after the indoor and outdoor units have been relocated.
- 7) Turn off the breaker. Remove the pressure gauge and the refrigerant piping.

WARNING

When pumping down the refrigerant, stop the compressor before disconnecting the refrigerant pipes. The compressor may burst and cause injury if any foreign substance, such as air, enters the pipes.

**MXZ-3E54VA MXZ-3E68VA MXZ-4E72VA
MXZ-4E83VA MXZ-5E102VA MXZ-2E53VAHZ MXZ-4E83VAHZ**

The standard specifications apply only to the operation of the air conditioner under normal conditions.

Since operating conditions vary according to the areas where these units are installed, the following information has been provided to clarify the operating characteristics of the air conditioner under the conditions indicated by the performance curve.

(1) GUARANTEED VOLTAGE

198 - 264 V 50 Hz

(2) AIR FLOW

Air flow should be set at MAX.

(3) MAIN READINGS

(1) Indoor intake air wet-bulb temperature:	°CWB	} Cooling
(2) Indoor outlet air wet-bulb temperature:	°CWB	
(3) Outdoor intake air dry-bulb temperature:	°CDB	
(4) Total input:	W	} Heating
(5) Indoor intake air dry-bulb temperature:	°CDB	
(6) Outdoor intake air wet-bulb temperature:	°CWB	
(7) Total input:	W	

Indoor air wet and dry bulb temperature difference on the left side of the following chart shows the difference between the indoor intake air wet and dry bulb temperature and the indoor outlet air wet and dry bulb temperature for your reference at service.

How to measure the indoor air wet and dry bulb temperature difference

1. Attach at least 2 sets of wet and dry bulb thermometers to the indoor air intake as shown in the figure, and at least 2 sets of wet and dry bulb thermometers to the indoor air outlet. The thermometers must be attached to the position where air speed is high.
2. Attach at least 2 sets of wet and dry bulb thermometers to the outdoor air intake. Cover the thermometers to prevent direct rays of the sun.
3. Check that the air filter is cleaned.
4. Open windows and doors of room.
5. Press the EMERGENCY OPERATION switch once (twice) to start the EMERGENCY COOL (HEAT) MODE.
6. When system stabilizes after more than 15 minutes, measure temperature and take an average temperature.
7. 10 minutes later, measure temperature again and check that the temperature does not change.

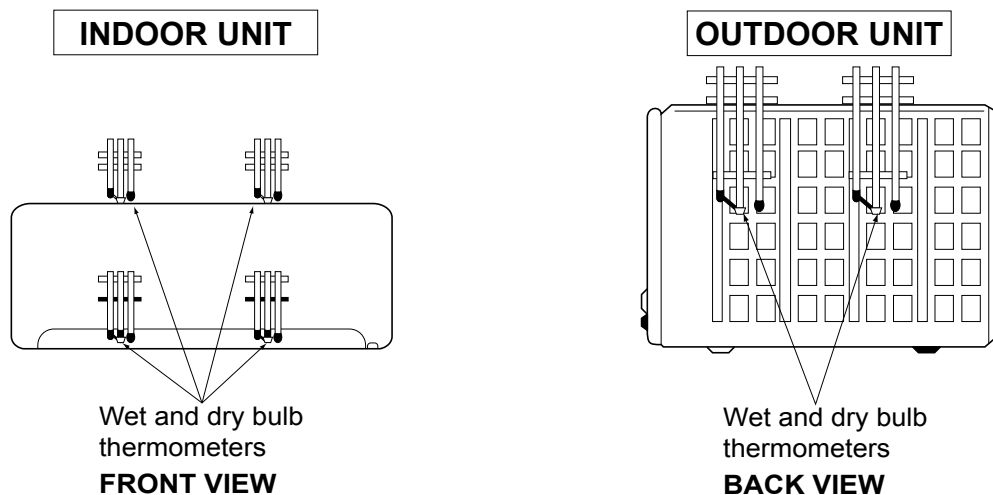

8-1. CAPACITY AND THE INPUT CURVES

MXZ-3E54VA MXZ-3E68VA MXZ-4E72VA

5.8	3.8	7.3	7.8	8.5	9.7	8.7	11.9	12.4
5.3	3.5	6.7	7.1	7.8	8.8	8.0	10.8	11.3
4.8	3.2	6.0	6.4	7.0	7.9	7.2	9.7	10.1
4.3	2.9	5.4	5.8	6.3	7.1	6.5	8.7	9.0
3.9	2.6	4.8	5.1	5.6	6.3	5.7	7.7	8.0
3.5	2.3	4.2	4.4	4.9	5.5	4.9	6.7	7.0
3.1	2.0	3.6	3.7	4.2	4.7	4.1	5.7	6.0
15 class	18 class	20 class	22 class	25 class	35 class	42 class	50 class	60 class

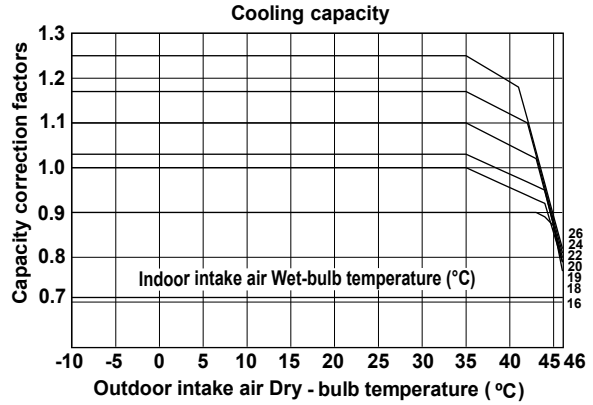

5.8	3.8	7.3	7.8	8.5	9.7	8.7	11.9	12.4
5.3	3.5	6.7	7.1	7.8	8.8	8.0	10.8	11.3
4.8	3.2	6.0	6.4	7.0	7.9	7.2	9.7	10.1
4.3	2.9	5.4	5.8	6.3	7.1	6.5	8.7	9.0
3.9	2.6	4.8	5.1	5.6	6.3	5.7	7.7	8.0
3.5	2.3	4.2	4.4	4.9	5.5	4.9	6.7	7.0
3.1	2.0	3.6	3.7	4.2	4.7	4.1	5.7	6.0
2.7	1.7	3.0	3.0	3.5	3.9	3.3	4.7	5.0
2.3	1.4	2.4	2.3	2.8	3.1	2.5	3.7	4.0
1.9	1.1	1.8	1.6	2.1	2.3	1.7	2.7	3.0
15 class	18 class	20 class	22 class	25 class	35 class	42 class	50 class	60 class

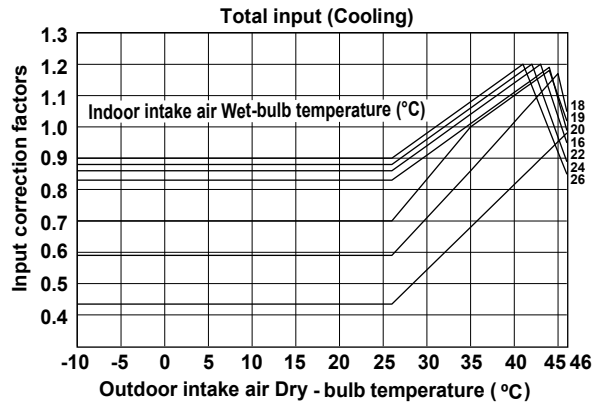

18.4	20.4	21.2	27.4	25.8	27.9	29.1	33.8	34.4
17.1	19.0	19.7	25.4	24.0	25.9	27.0	31.4	31.9
15.8	17.6	18.2	23.4	22.2	23.9	24.9	29.0	29.4
14.5	16.1	16.7	21.5	20.3	21.9	22.8	26.6	27.0
13.2	14.5	15.2	19.5	18.5	19.9	20.7	24.1	24.5
11.8	13.0	13.6	17.6	16.6	17.9	18.7	21.7	22.1
10.5	11.6	12.1	15.6	14.8	15.9	16.6	19.3	19.6
9.2	10.0	10.6	13.7	12.9	13.9	14.5	16.9	17.2
7.9	8.6	9.1	11.7	11.1	12.0	12.4	14.5	14.7
6.6	7.2	7.6	9.7	9.3	10.1	10.3	12.1	12.2
5.3	5.8	6.1	7.7	7.5	8.2	8.2	9.7	9.7
15 class	18 class	20 class	22 class	25 class	35 class	42 class	50 class	60 class

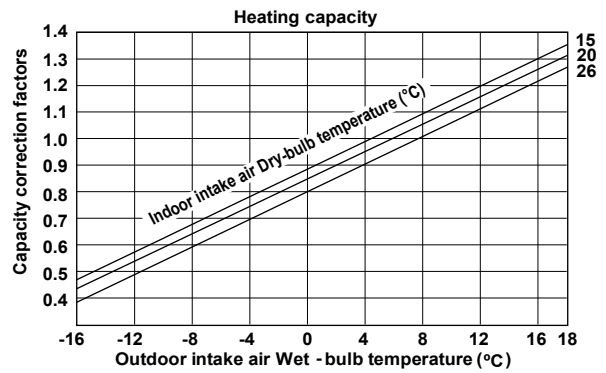

17.1	19.0	19.7	25.4	24.0	25.9	27.0	31.4	31.9
15.8	17.6	18.2	23.4	22.2	23.9	24.9	29.0	29.4
14.5	16.1	16.7	21.5	20.3	21.9	22.8	26.6	27.0
13.2	14.5	15.2	19.5	18.5	19.9	20.7	24.1	24.5
11.8	13.0	13.6	17.6	16.6	17.9	18.7	21.7	22.1
10.5	11.6	12.1	15.6	14.8	15.9	16.6	19.3	19.6
9.2	10.0	10.6	13.7	12.9	13.9	14.5	16.9	17.2
7.9	8.6	9.1	11.7	11.1	12.0	12.4	14.5	14.7
6.6	7.2	7.6	9.7	9.3	10.1	10.3	12.1	12.2
5.3	5.8	6.1	7.7	7.5	8.2	8.2	9.7	9.7
15 class	18 class	20 class	22 class	25 class	35 class	42 class	50 class	60 class

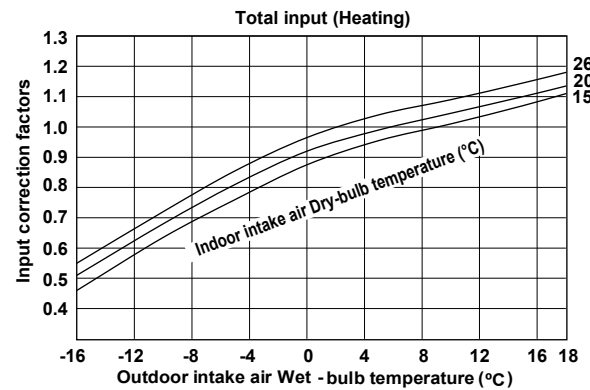

MXZ-4E83VA MXZ-5E102VA

5.4	3.8	6.8	4.8	5.5	8.0	10.2	11.6	8.0	8.2
4.9	3.5	6.2	4.4	5.0	7.3	9.3	10.6	7.3	7.5
4.5	3.2	5.7	4.0	4.6	6.6	8.4	9.5	6.6	6.8
4.0	2.9	5.1	3.6	4.1	6.0	7.5	8.5	6.0	6.1
3.6	2.6	4.5	3.2	3.7	5.3	6.6	7.5	5.3	5.4
3.2	2.3	4.0	2.8	3.2	4.6	5.8	6.6	4.6	4.7
2.8	2.0	3.5	2.5	2.8	4.0	5.0	5.6	4.0	4.1
15 class	18 class	20 class	22 class	25 class	35 class	42 class	50 class	60 class	71 class

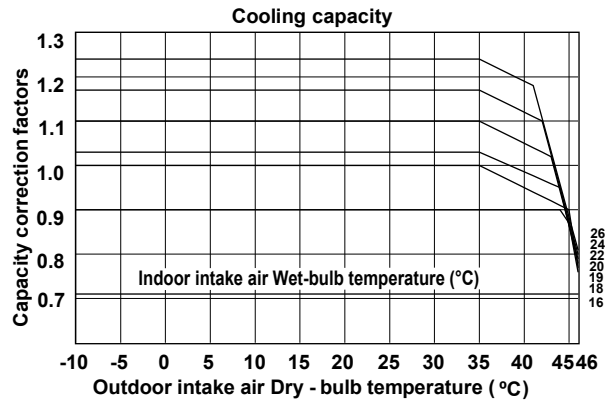

5.4	3.8	6.8	4.8	5.5	8.0	10.2	11.6	8.0	8.2
4.9	3.5	6.2	4.4	5.0	7.3	9.3	10.6	7.3	7.5
4.5	3.2	5.7	4.0	4.6	6.6	8.4	9.5	6.6	6.8
4.0	2.9	5.1	3.6	4.1	6.0	7.5	8.5	6.0	6.1
3.6	2.6	4.5	3.2	3.7	5.3	6.6	7.5	5.3	5.4
3.2	2.3	4.0	2.8	3.2	4.6	5.8	6.6	4.6	4.7
2.8	2.0	3.5	2.5	2.8	4.0	5.0	5.6	4.0	4.1
2.3	1.7	2.9	2.1	2.0	3.4	4.2	4.8	3.4	3.5
1.9	1.4	2.4	1.7	2.0	2.8	3.5	3.9	2.8	2.9
1.5	1.1	1.9	1.4	1.6	2.2	2.7	3.1	2.2	2.3
15 class	18 class	20 class	22 class	25 class	35 class	42 class	50 class	60 class	71 class

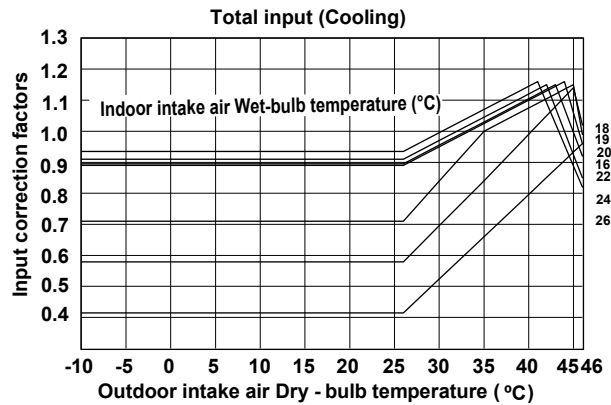

18.3	19.7	22.0	19.7	19.7	23.0	31.1	32.1	22.3	28.3
17.0	18.2	20.5	18.2	18.2	21.4	28.9	29.8	20.7	26.3
15.7	16.8	18.9	16.8	16.8	19.7	26.6	27.5	19.1	24.3
14.4	15.4	17.3	15.4	15.4	18.1	24.4	25.2	17.5	22.3
12.9	13.9	15.6	13.9	13.9	16.3	21.9	22.7	15.7	20.0
11.6	12.5	14.0	12.5	12.5	14.6	19.7	20.4	14.2	18.0
10.3	11.1	12.4	11.1	11.1	13.0	17.6	18.1	12.6	16.0
9.0	9.7	10.9	9.7	9.7	11.4	15.4	15.9	11.0	14.0
7.7	8.2	9.2	8.2	8.2	9.6	13.0	13.4	9.3	11.9
6.4	6.9	7.7	6.9	6.9	8.0	10.8	11.2	7.8	9.9
5.1	5.5	6.1	5.5	5.5	6.4	8.7	9.0	6.2	7.9
15 class	18 class	20 class	22 class	25 class	35 class	42 class	50 class	60 class	71 class

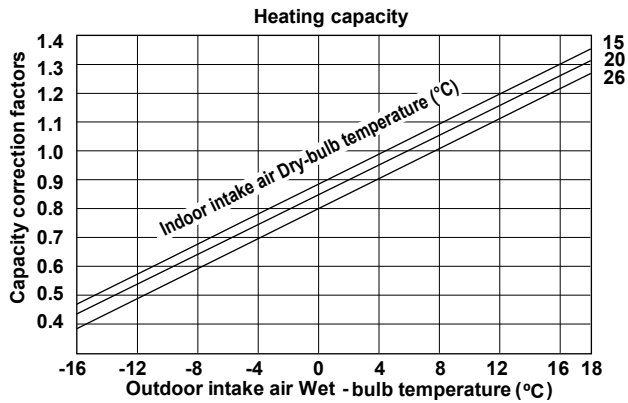

17.0	18.2	20.5	18.2	18.2	21.4	28.9	29.8	20.7	26.3
15.7	16.8	18.9	16.8	16.8	19.7	26.6	27.5	19.1	24.3
14.4	15.4	17.3	15.4	15.4	18.1	24.4	25.2	17.5	22.3
12.9	13.9	15.6	13.9	13.9	16.3	21.9	22.7	15.7	20.0
11.6	12.5	14.0	12.5	12.5	14.6	19.7	20.4	14.2	18.0
10.3	11.1	12.4	11.1	11.1	13.0	17.6	18.1	12.6	16.0
9.0	9.7	10.9	9.7	9.7	11.4	15.4	15.9	11.0	14.0
7.7	8.2	9.2	8.2	8.2	9.6	13.0	13.4	9.3	11.9
6.4	6.9	7.7	6.9	6.9	8.0	10.8	11.2	7.8	9.9
5.1	5.5	6.1	5.5	5.5	6.4	8.7	9.0	6.2	7.9
15 class	18 class	20 class	22 class	25 class	35 class	42 class	50 class	60 class	71 class

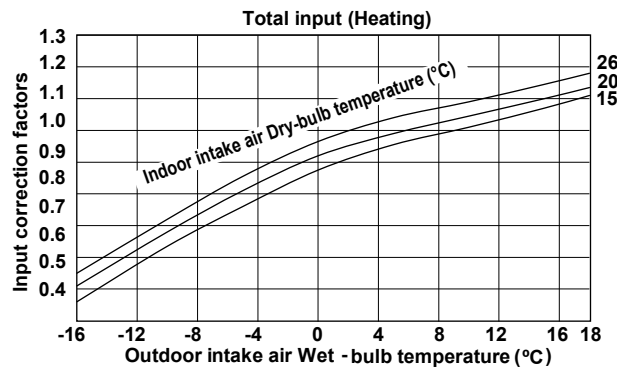

MXZ-2E53VAHZ

5.4	3.8	6.8	4.8	5.5	8.0	10.2	11.6
4.9	3.5	6.2	4.4	5.0	7.3	9.3	10.6
4.5	3.2	5.7	4.0	4.6	6.6	8.4	9.5
4.0	2.9	5.1	3.6	4.1	6.0	7.5	8.5
3.6	2.6	4.5	3.2	3.7	5.3	6.6	7.5
3.2	2.3	4.0	2.8	3.2	4.6	5.8	6.6
2.8	2.0	3.5	2.5	2.8	4.0	5.0	5.6
15 class	18 class	20 class	22 class	25 class	35 class	42 class	50 class

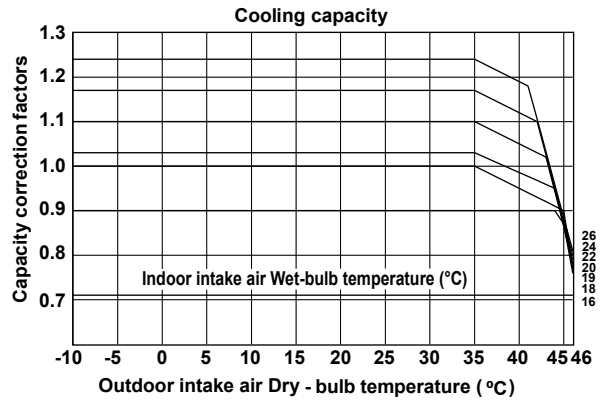

5.4	3.8	6.8	4.8	5.5	8.0	10.2	11.6
4.9	3.5	6.2	4.4	5.0	7.3	9.3	10.6
4.5	3.2	5.7	4.0	4.6	6.6	8.4	9.5
4.0	2.9	5.1	3.6	4.1	6.0	7.5	8.5
3.6	2.6	4.5	3.2	3.7	5.3	6.6	7.5
3.2	2.3	4.0	2.8	3.2	4.6	5.8	6.6
2.8	2.0	3.5	2.5	2.8	4.0	5.0	5.6
2.3	1.7	2.9	2.1	2.0	3.4	4.2	4.8
1.9	1.4	2.4	1.7	2.0	2.8	3.5	3.9
1.5	1.1	1.9	1.4	1.6	2.2	2.7	3.1
15 class	18 class	20 class	22 class	25 class	35 class	42 class	50 class

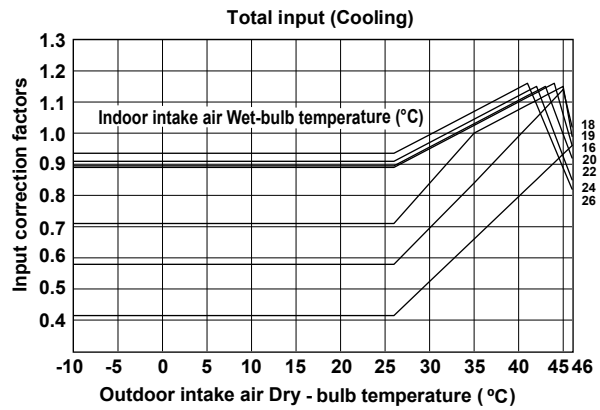

18.3	19.7	22.0	19.7	19.7	23.0	31.1	32.1
17.0	18.2	20.5	18.2	18.2	21.4	28.9	29.8
15.7	16.8	18.9	16.8	16.8	19.7	26.6	27.5
14.4	15.4	17.3	15.4	15.4	18.1	24.4	25.2
12.9	13.9	15.6	13.9	13.9	16.3	21.9	22.7
11.6	12.5	14.0	12.5	12.5	14.6	19.7	20.4
10.3	11.1	12.4	11.1	11.1	13.0	17.6	18.1
9.0	9.7	10.9	9.7	9.7	11.4	15.4	15.9
7.7	8.2	9.2	8.2	8.2	9.6	13.0	13.4
6.4	6.9	7.7	6.9	6.9	8.0	10.8	11.2
15 class	18 class	20 class	22 class	25 class	35 class	42 class	50 class

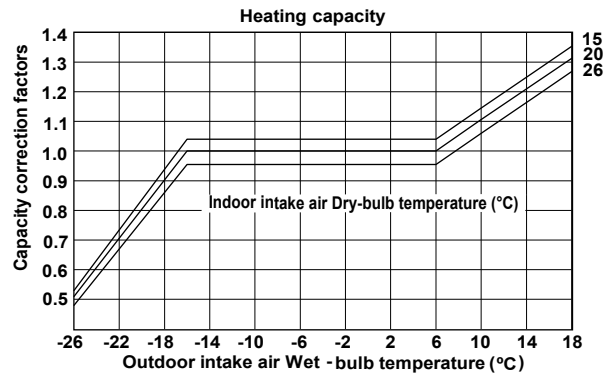

22.2	24.2	26.5	24.2	24.2	27.8	37.7	39.0
20.9	22.7	25.0	22.7	22.7	26.2	35.5	36.7
19.6	21.2	23.5	21.2	21.2	24.6	33.3	34.4
18.3	19.7	22.0	19.7	19.7	23.0	31.1	32.1
17.0	18.2	20.5	18.2	18.2	21.4	28.9	29.8
15.7	16.8	18.9	16.8	16.8	19.7	26.6	27.5
14.4	15.4	17.3	15.4	15.4	18.1	24.4	25.2
12.9	13.9	15.6	13.9	13.9	16.3	21.9	22.7
11.6	12.5	14.0	12.5	12.5	14.6	19.7	20.4
10.3	11.1	12.4	11.1	11.1	13.0	17.6	18.1
9.0	9.7	10.9	9.7	9.7	11.4	15.4	15.9
7.7	8.2	9.2	8.2	8.2	9.6	13.0	13.4
6.4	6.9	7.7	6.9	6.9	8.0	10.8	11.2
15 class	18 class	20 class	22 class	25 class	35 class	42 class	50 class

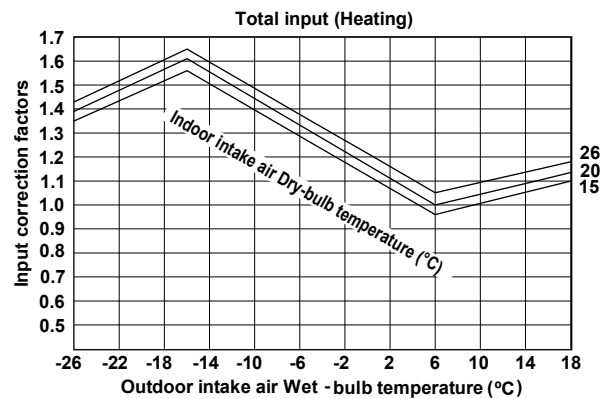

MXZ-4E83VAHZ

5.4	3.8	6.8	4.8	5.5	8.0	10.2	11.6	8.0	8.2
4.9	3.5	6.2	4.4	5.0	7.3	9.3	10.6	7.3	7.5
4.5	3.2	5.7	4.0	4.6	6.6	8.4	9.5	6.6	6.8
4.0	2.9	5.1	3.6	4.1	6.0	7.5	8.5	6.0	6.1
3.6	2.6	4.5	3.2	3.7	5.3	6.6	7.5	5.3	5.4
3.2	2.3	4.0	2.8	3.2	4.6	5.8	6.6	4.6	4.7
2.8	2.0	3.5	2.5	2.8	4.0	5.0	5.6	4.0	4.1
15 class	18 class	20 class	22 class	25 class	35 class	42 class	50 class	60 class	71 class

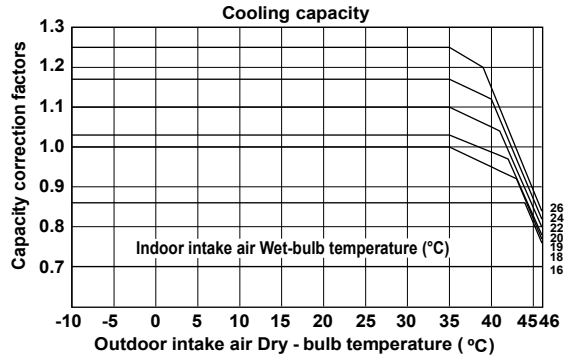

5.4	3.8	6.8	4.8	5.5	8.0	10.2	11.6	8.0	8.2
4.9	3.5	6.2	4.4	5.0	7.3	9.3	10.6	7.3	7.5
4.5	3.2	5.7	4.0	4.6	6.6	8.4	9.5	6.6	6.8
4.0	2.9	5.1	3.6	4.1	6.0	7.5	8.5	6.0	6.1
3.6	2.6	4.5	3.2	3.7	5.3	6.6	7.5	5.3	5.4
3.2	2.3	4.0	2.8	3.2	4.6	5.8	6.6	4.6	4.7
2.8	2.0	3.5	2.5	2.8	4.0	5.0	5.6	4.0	4.1
2.3	1.7	2.9	2.1	2.0	3.4	4.2	4.8	3.4	3.5
1.9	1.4	2.4	1.7	2.0	2.8	3.5	3.9	2.8	2.9
1.5	1.1	1.9	1.4	1.6	2.2	2.7	3.1	2.2	2.3
15 class	18 class	20 class	22 class	25 class	35 class	42 class	50 class	60 class	71 class

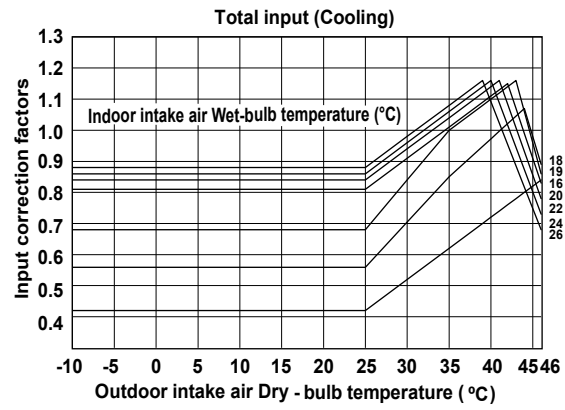

18.3	19.7	22.0	19.7	19.7	23.0	31.1	32.1	22.3	28.3
17.0	18.2	20.5	18.2	18.2	21.4	28.9	29.8	20.7	26.3
15.7	16.8	18.9	16.8	16.8	19.7	26.6	27.5	19.1	24.3
14.4	15.4	17.3	15.4	15.4	18.1	24.4	25.2	17.5	22.3
12.9	13.9	15.6	13.9	13.9	16.3	21.9	22.7	15.7	20.0
11.6	12.5	14.0	12.5	12.5	14.6	19.7	20.4	14.2	18.0
10.3	11.1	12.4	11.1	11.1	13.0	17.6	18.1	12.6	16.0
9.0	9.7	10.9	9.7	9.7	11.4	15.4	15.9	11.0	14.0
7.7	8.2	9.2	8.2	8.2	9.6	13.0	13.4	9.3	11.9
6.4	6.9	7.7	6.9	6.9	8.0	10.8	11.2	7.8	9.9
15 class	18 class	20 class	22 class	25 class	35 class	42 class	50 class	60 class	71 class

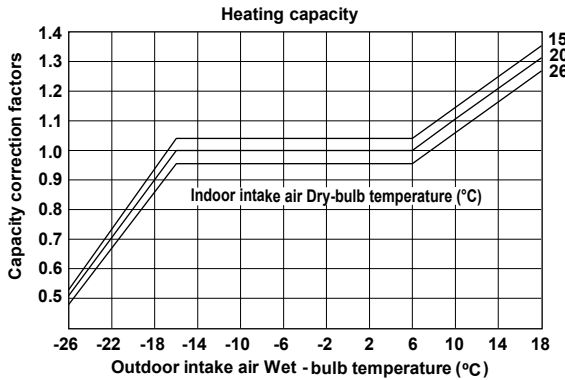

22.2	24.2	26.5	24.2	24.2	27.8	37.7	39.0	27.1	34.3
20.9	22.7	25.0	22.7	22.7	26.2	35.5	36.7	25.5	32.3
19.6	21.2	23.5	21.2	21.2	24.6	33.3	34.4	23.9	30.3
18.3	19.7	22.0	19.7	19.7	23.0	31.1	32.1	22.3	28.3
17.0	18.2	20.5	18.2	18.2	21.4	28.9	29.8	20.7	26.3
15.7	16.8	18.9	16.8	16.8	19.7	26.6	27.5	19.1	24.3
14.4	15.4	17.3	15.4	15.4	18.1	24.4	25.2	17.5	22.3
12.9	13.9	15.6	13.9	13.9	16.3	21.9	22.7	15.7	20.0
11.6	12.5	14.0	12.5	12.5	14.6	19.7	20.4	14.2	18.0
10.3	11.1	12.4	11.1	11.1	13.0	17.6	18.1	12.6	16.0
9.0	9.7	10.9	9.7	9.7	11.4	15.4	15.9	11.0	14.0
7.7	8.2	9.2	8.2	8.2	9.6	13.0	13.4	9.3	11.9
6.4	6.9	7.7	6.9	6.9	8.0	10.8	11.2	7.8	9.9
15 class	18 class	20 class	22 class	25 class	35 class	42 class	50 class	60 class	71 class

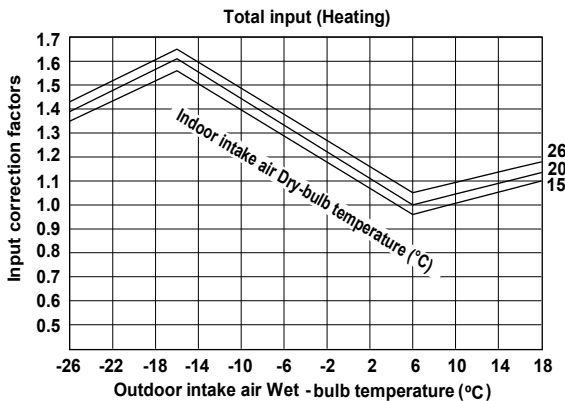

8-2. CAPACITY AND INPUT CORRECTION BY INVERTER OUTPUT FREQUENCY (single operation)

MXZ-3E54VA

15-class unit

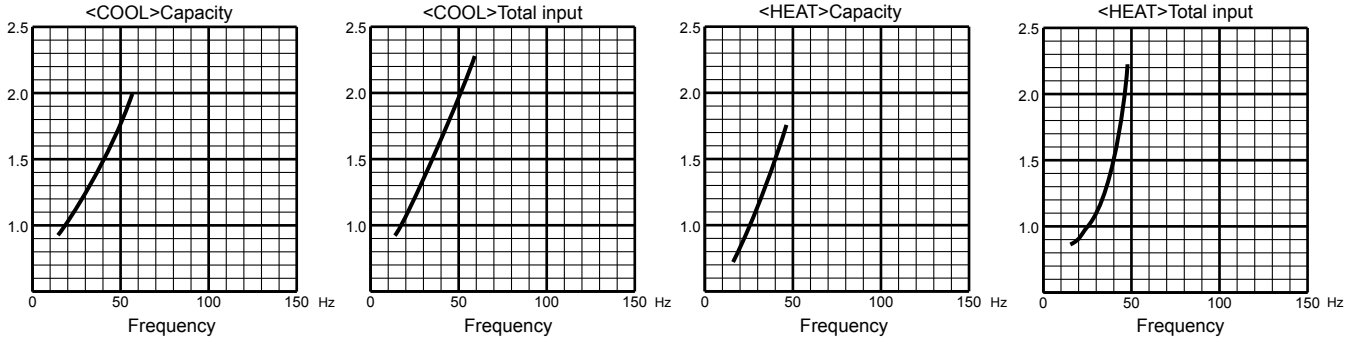

18-class unit

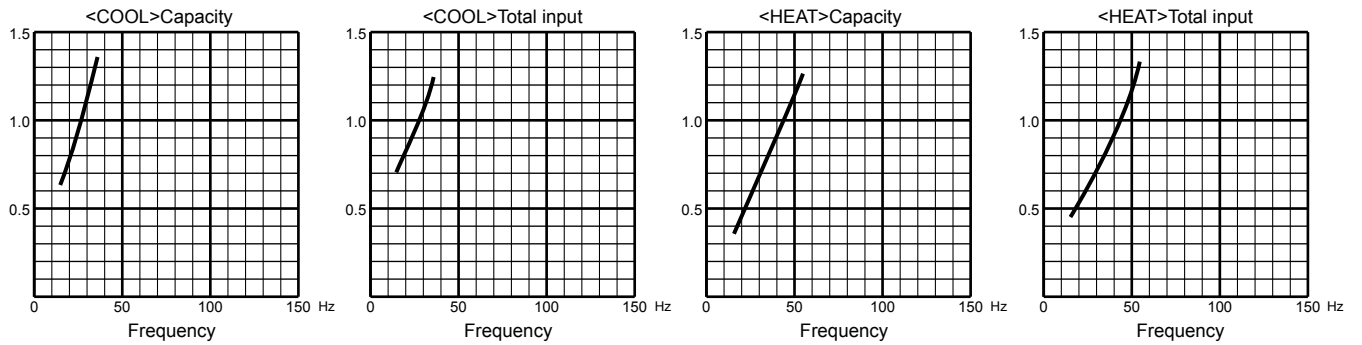

20-class unit

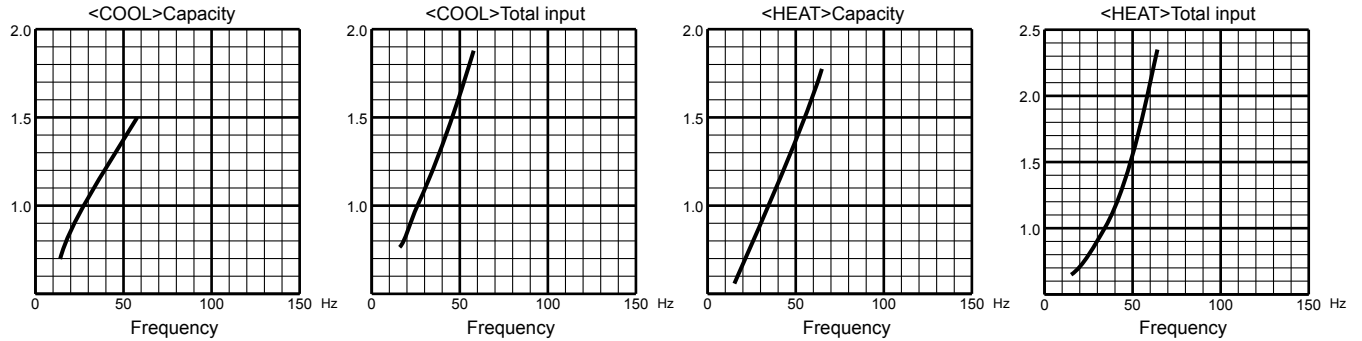

22-class unit

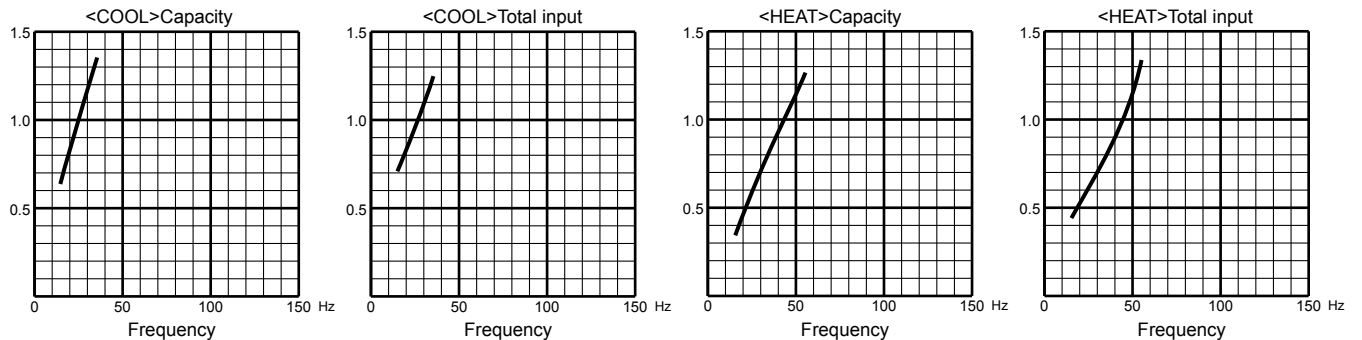

MXZ-3E54VA

25-class unit

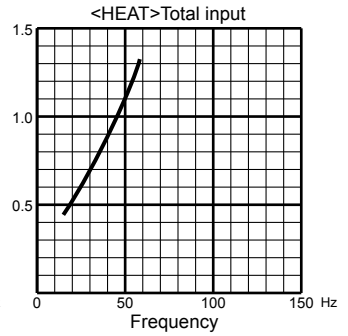
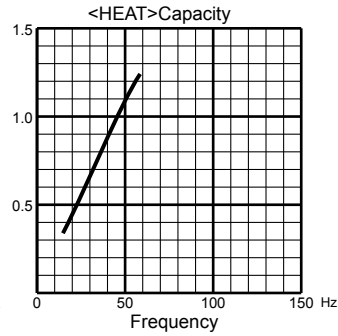
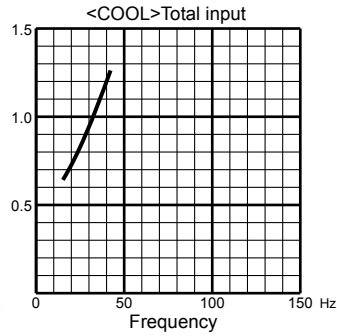
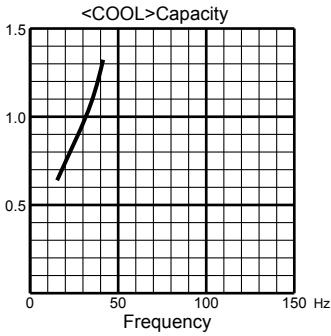

35-class unit

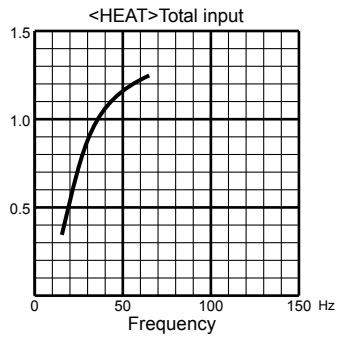
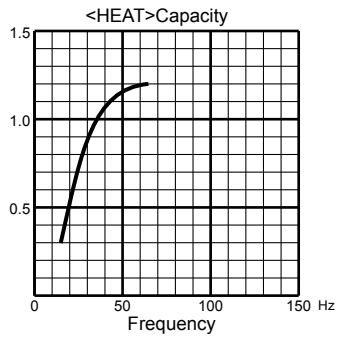
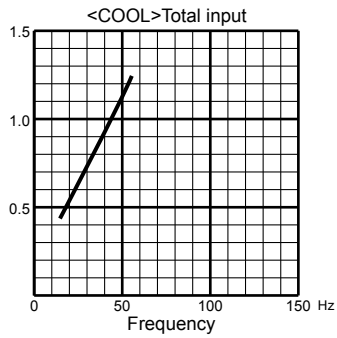
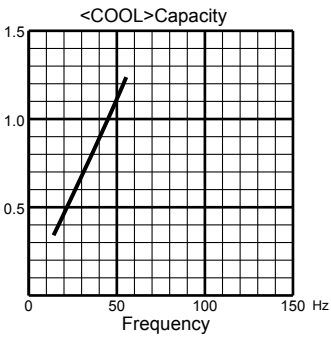

42-class unit

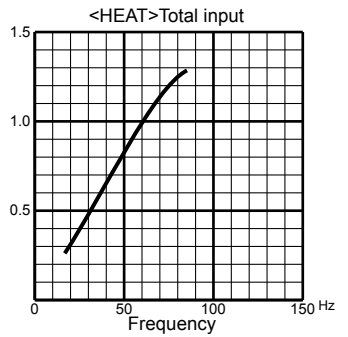
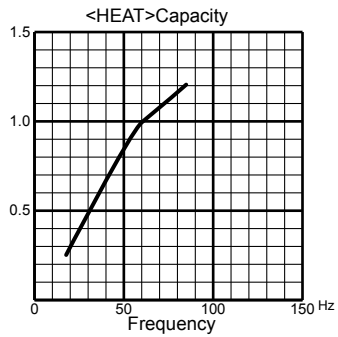
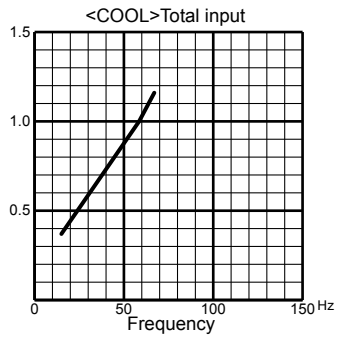
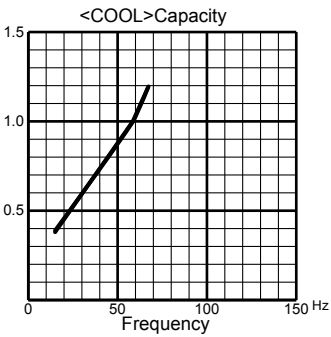

50-class unit

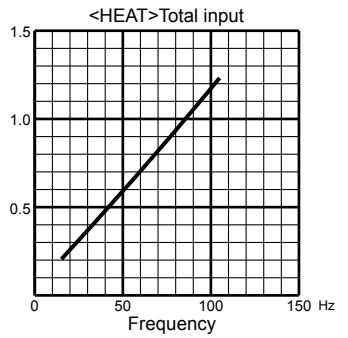
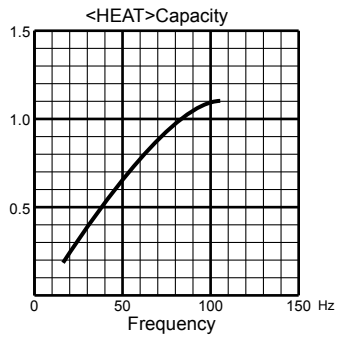
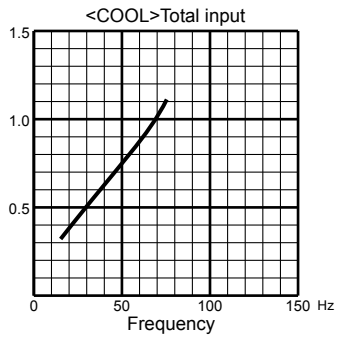
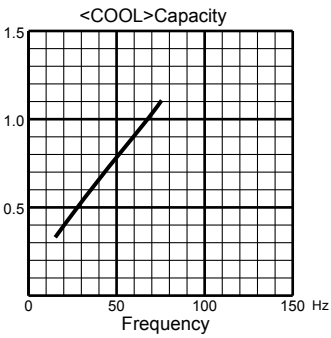

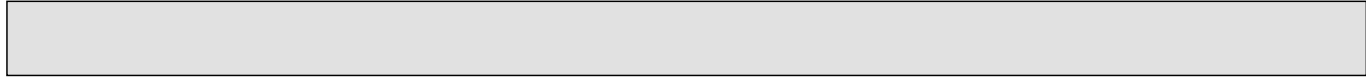

MXZ-3E68VA
15-class unit

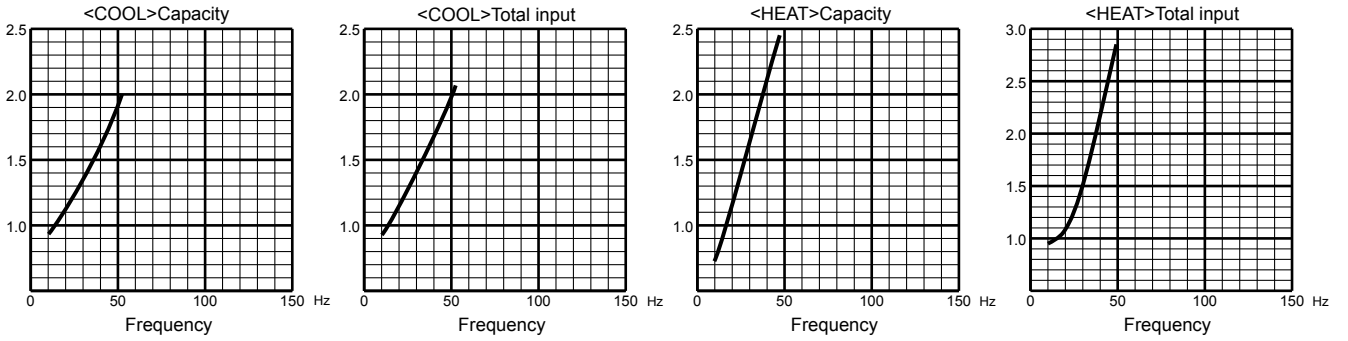

18-class unit

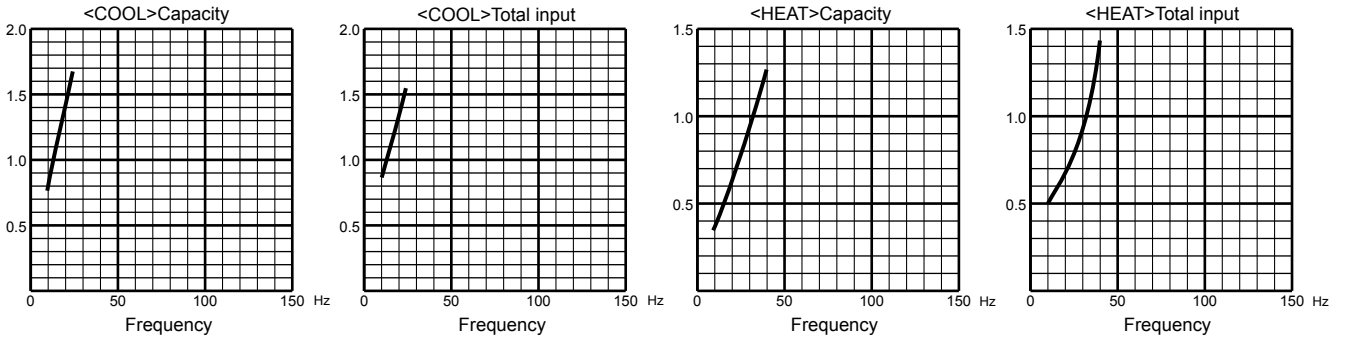

20-class unit

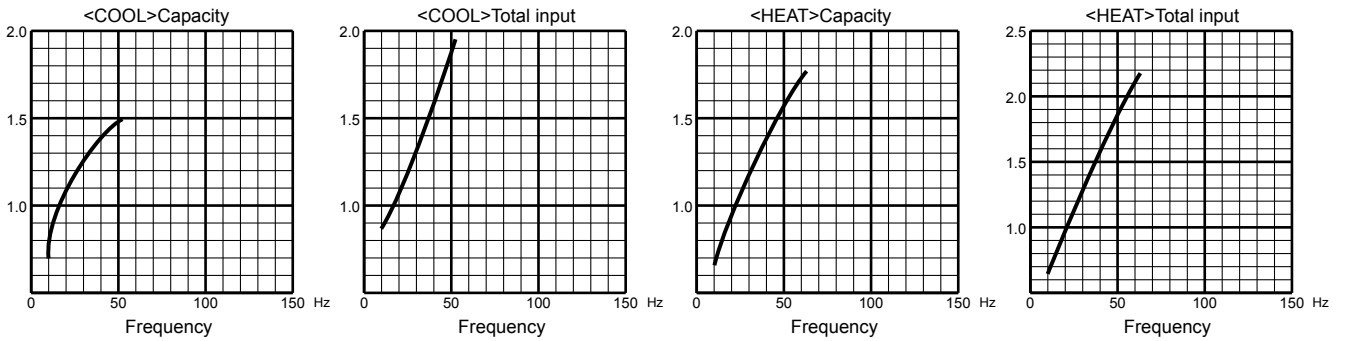

22-class unit

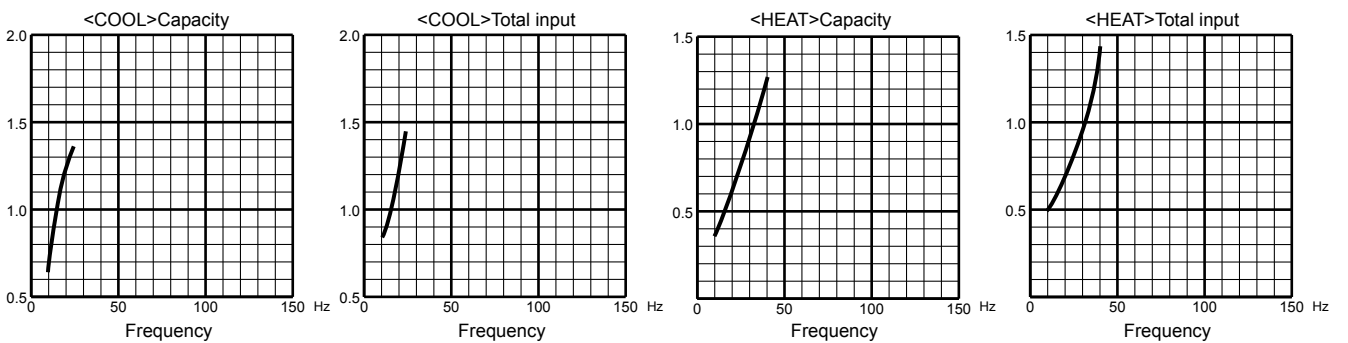

25-class unit

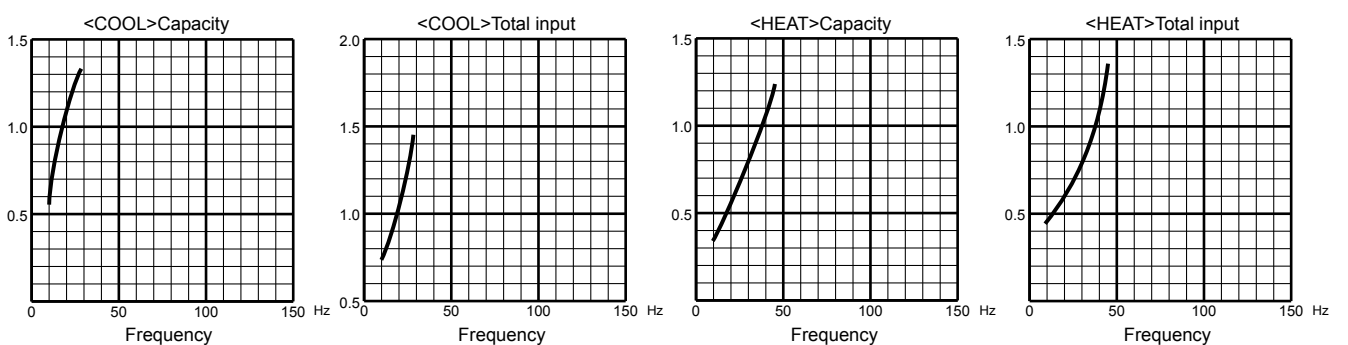

MXZ-3E68VA
35-class unit

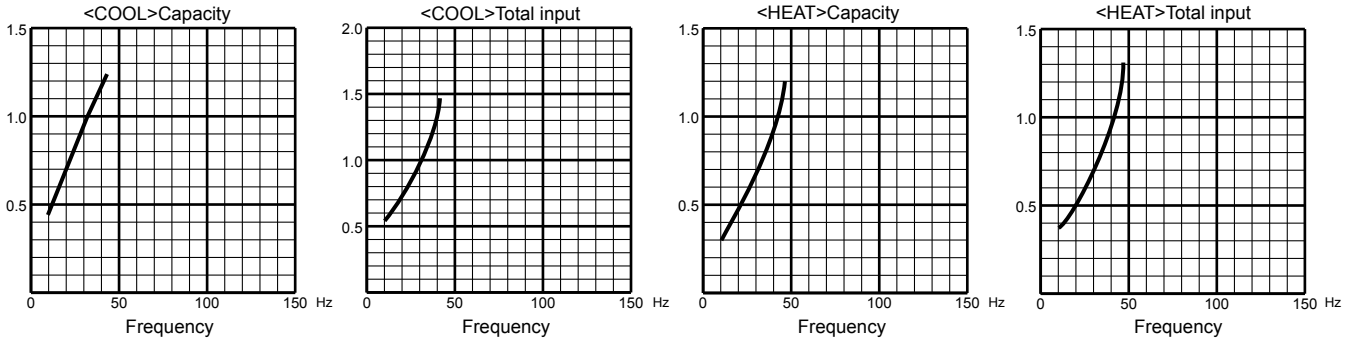

42-class unit

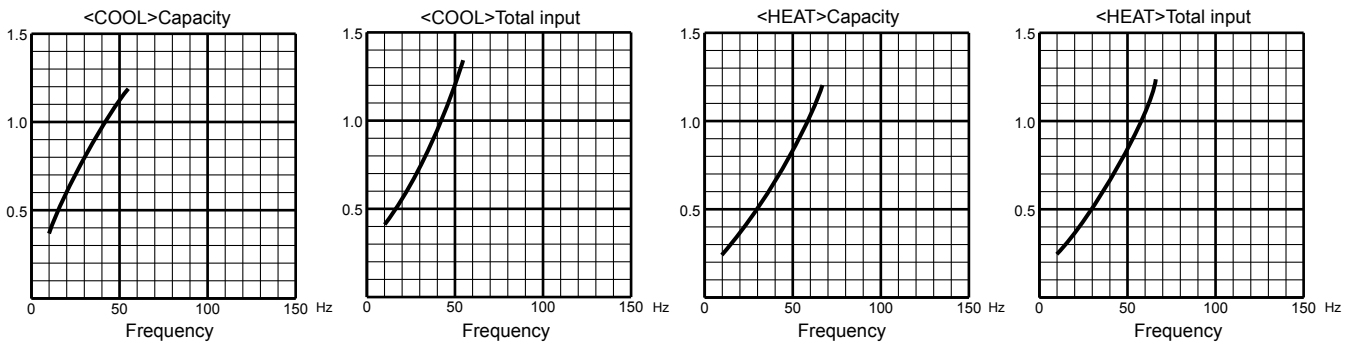

50-class unit

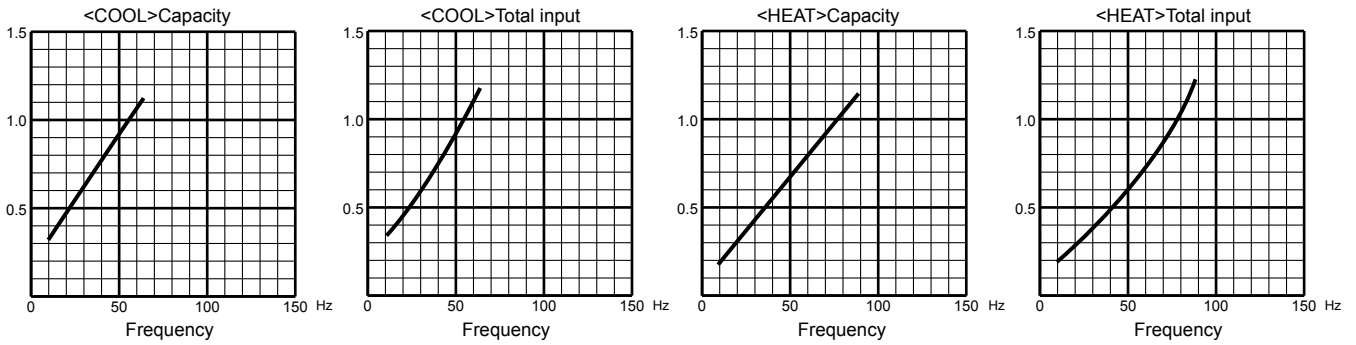

60-class unit

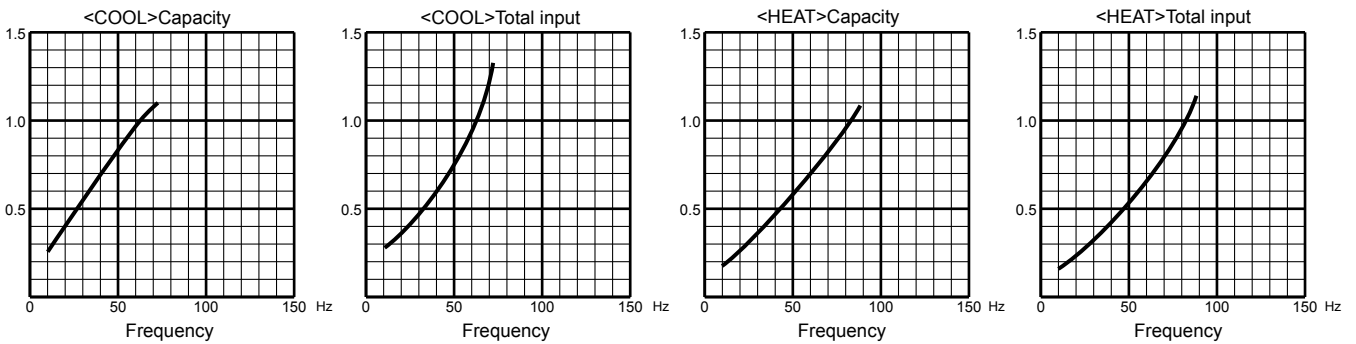

MXZ-4E72VA
15-class unit

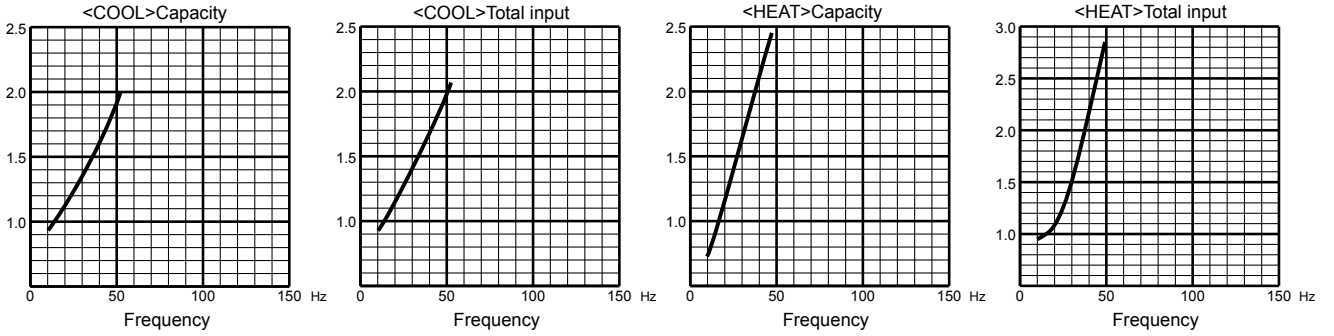

18-class unit

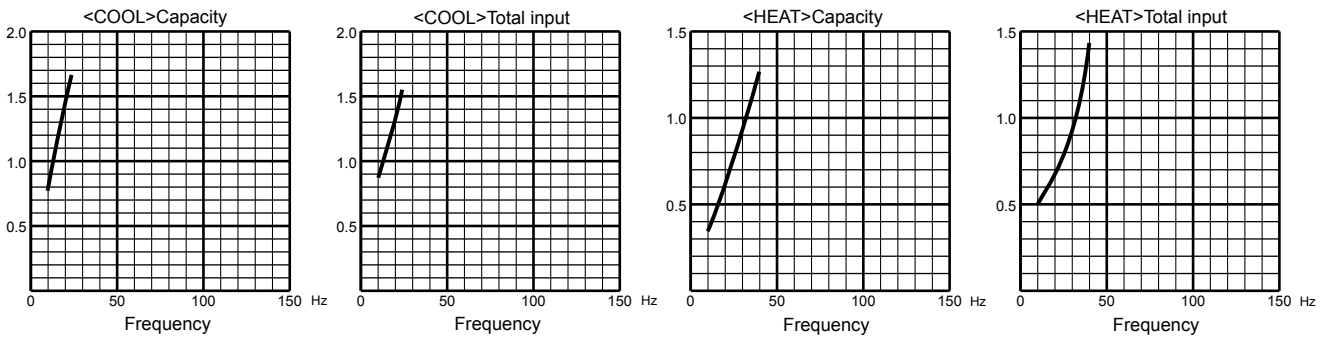

20-class unit

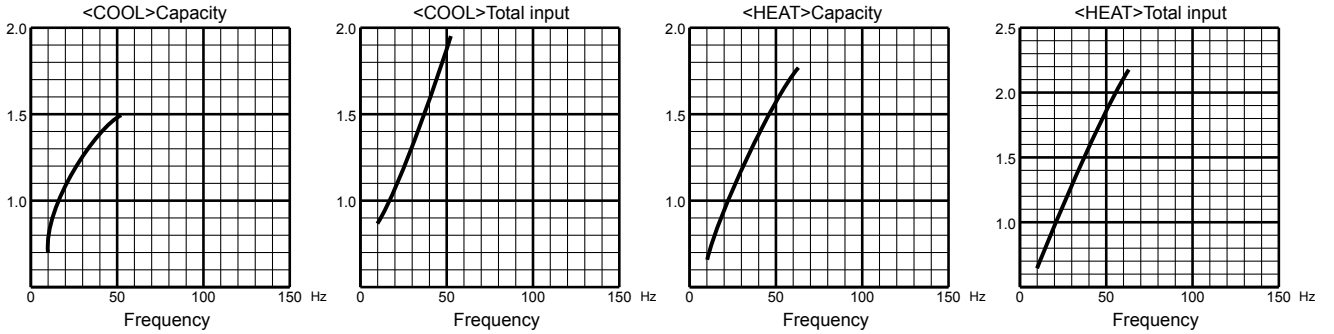

22-class unit

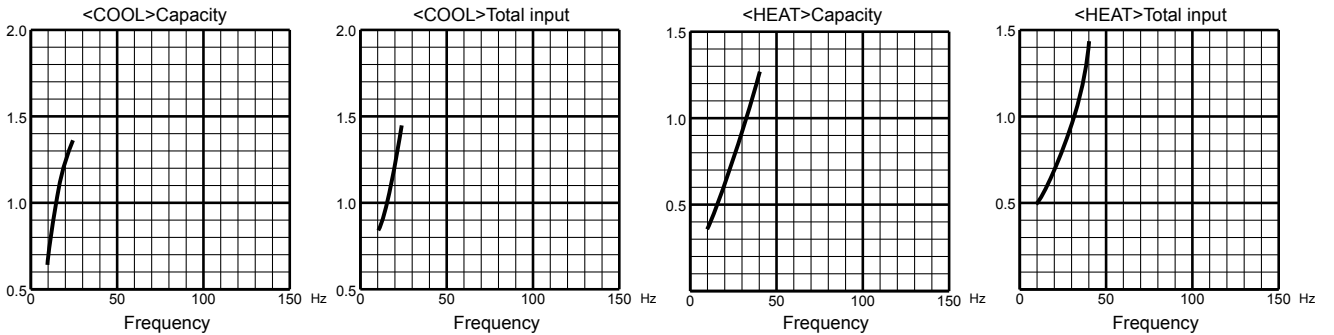

25-class unit

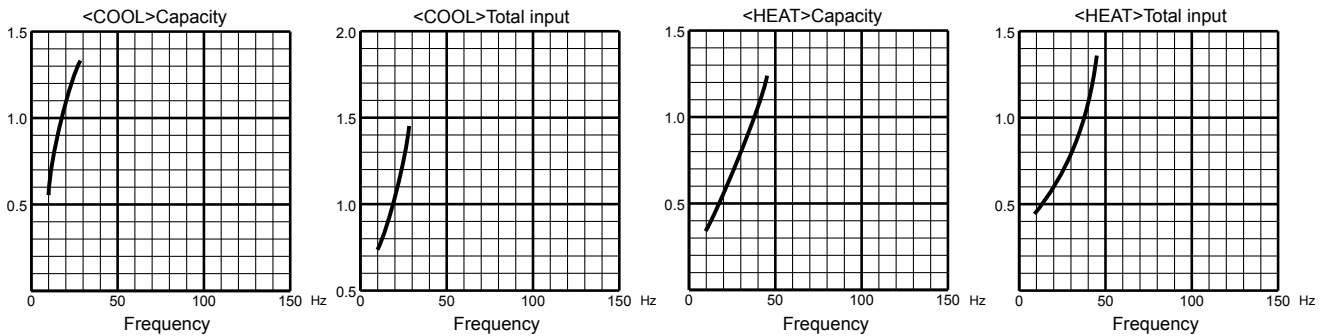

MXZ-4E72VA

35-class unit

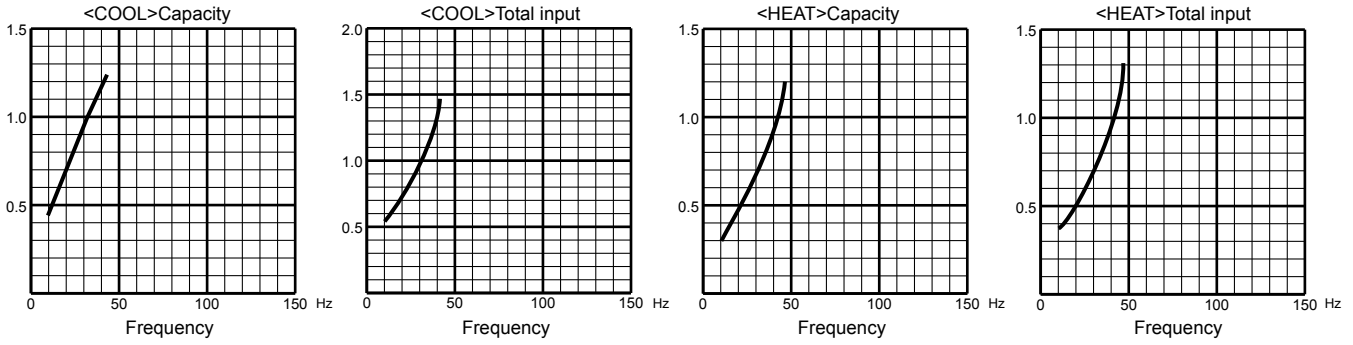

42-class unit

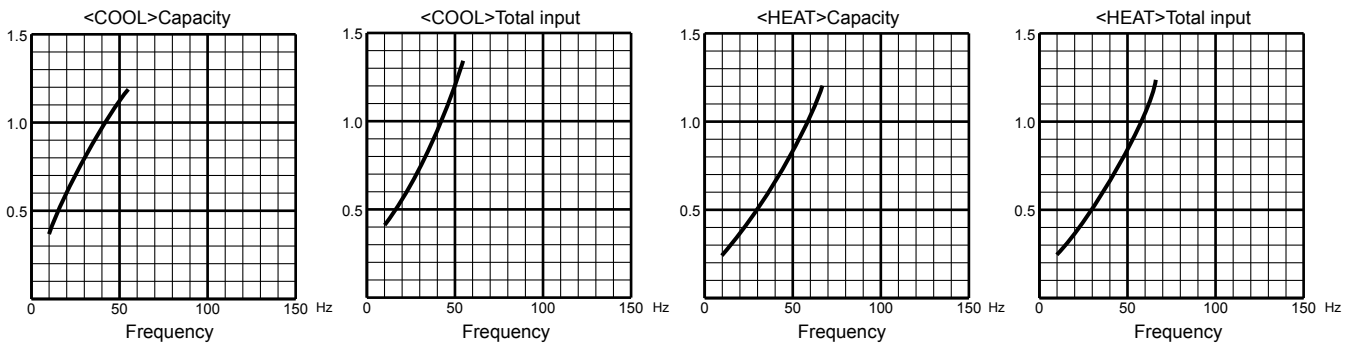

50-class unit

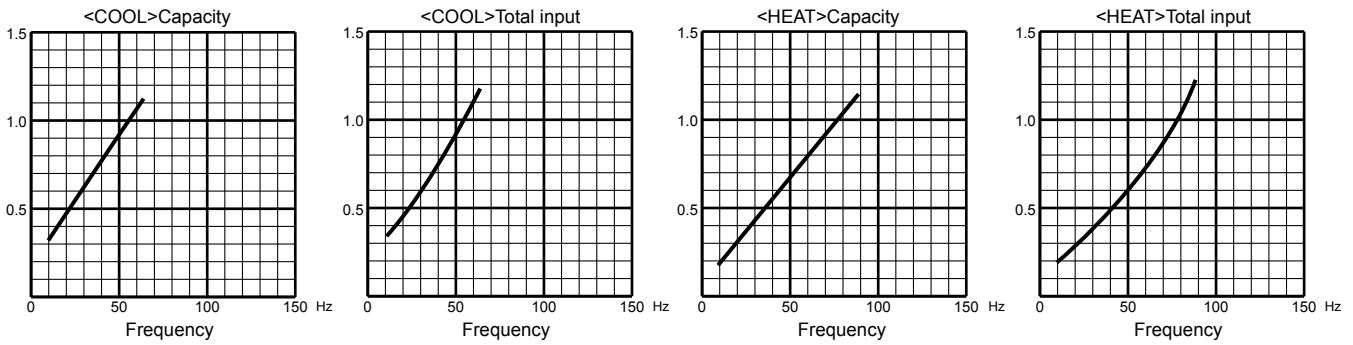

60-class unit

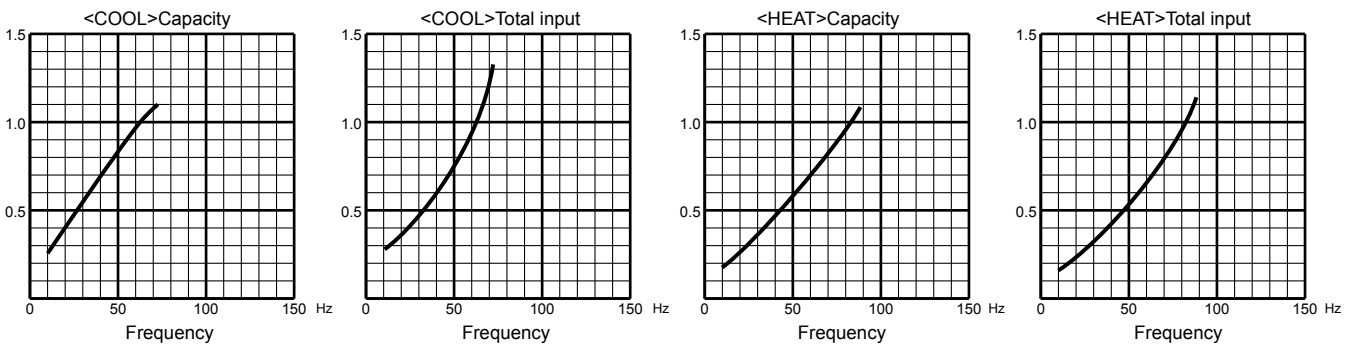

MXZ-4E83VA
15-class unit

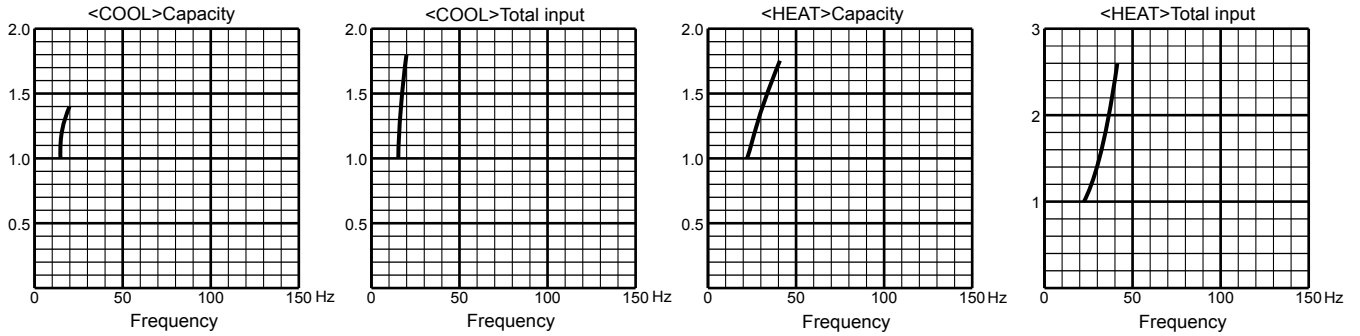

18-class unit

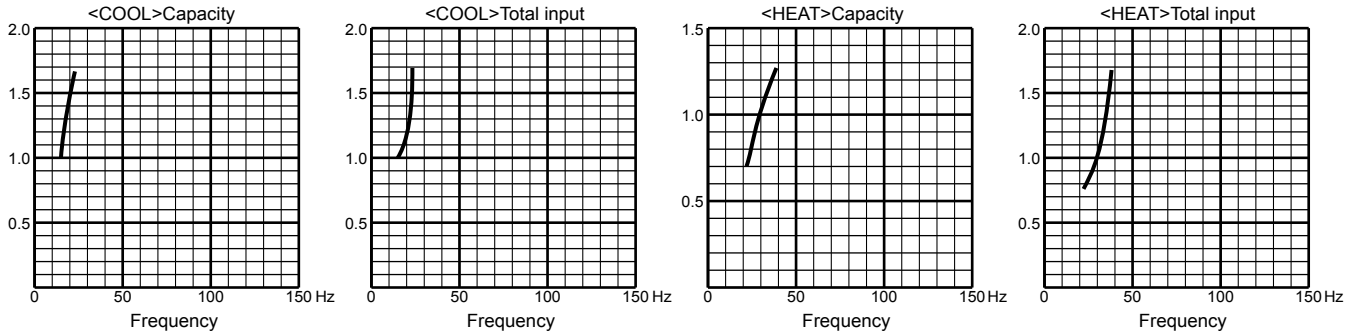

20-class unit

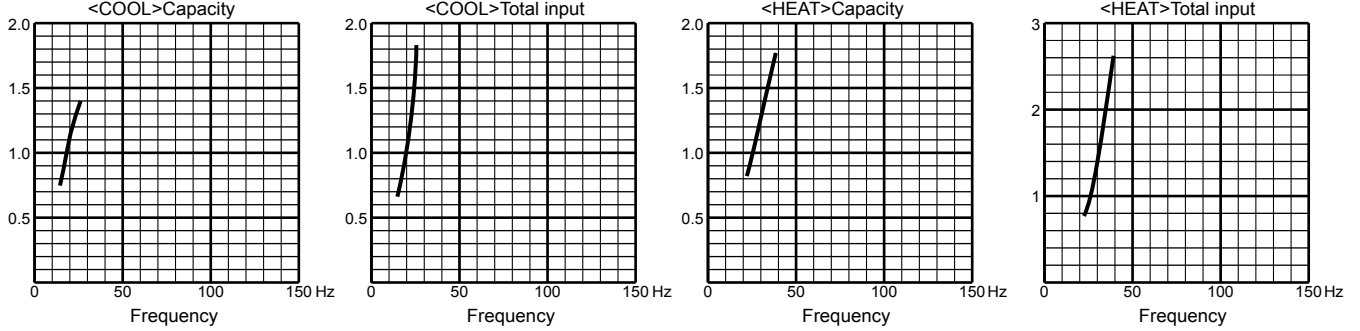

22-class unit

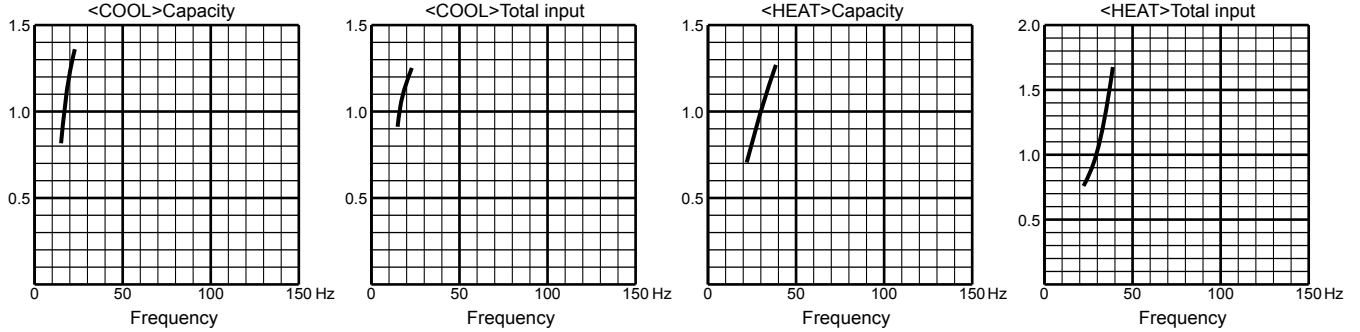

25-class unit

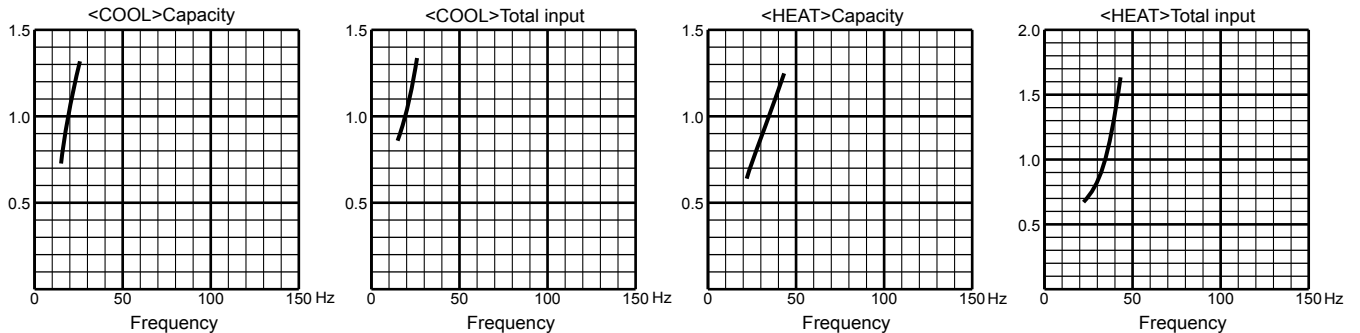

MXZ-4E83VA

35-class unit

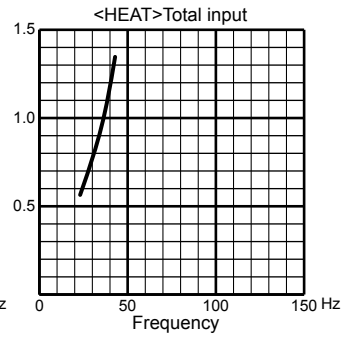
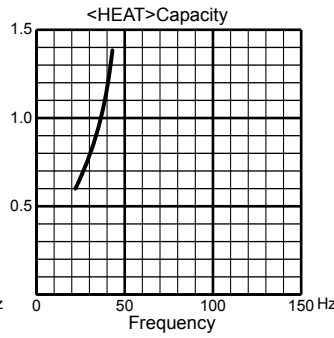
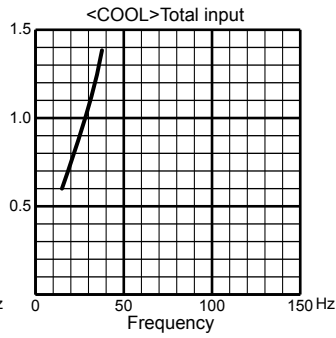
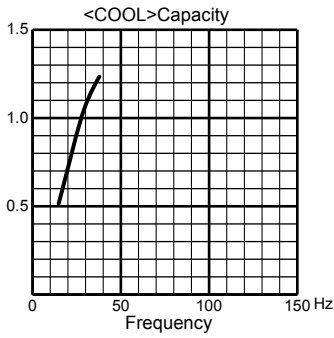

42-class unit

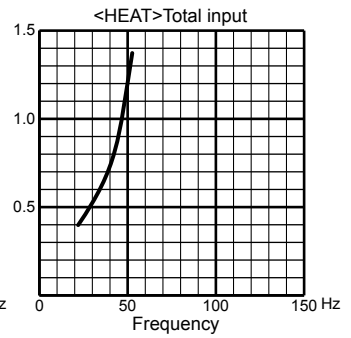
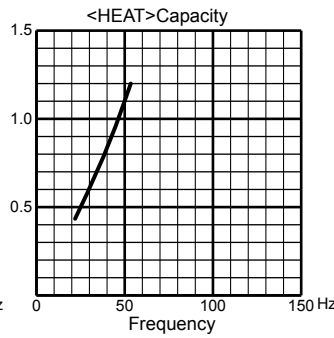
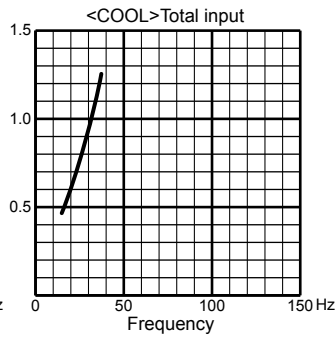
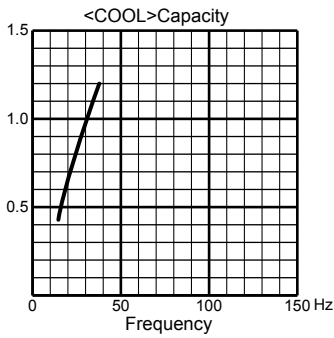

50-class unit

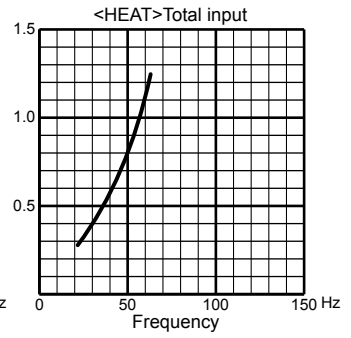
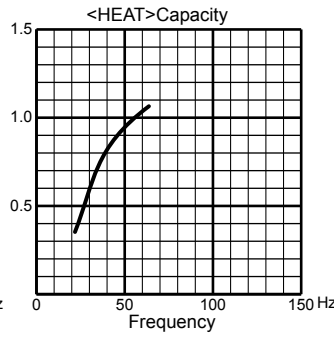
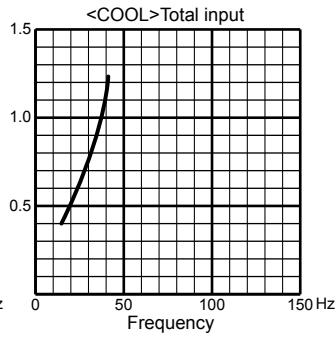
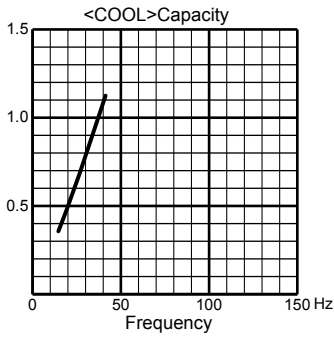

60-class unit

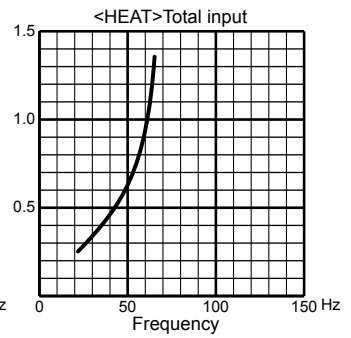
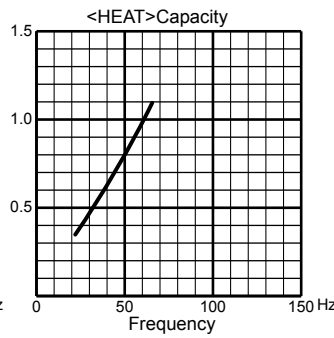
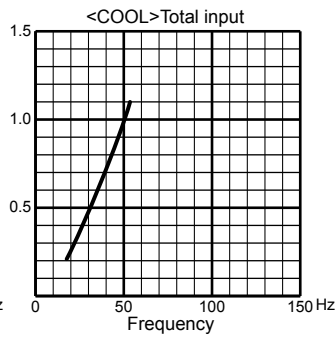
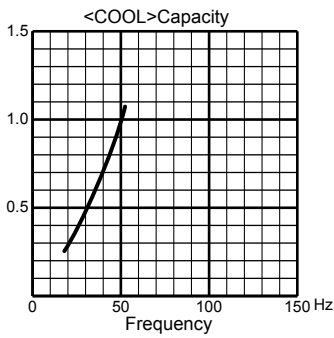

71-class unit

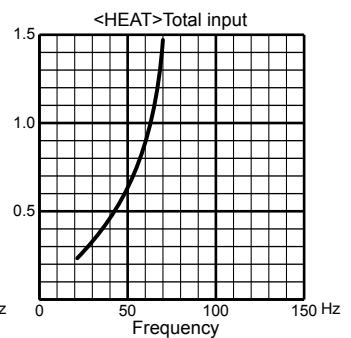
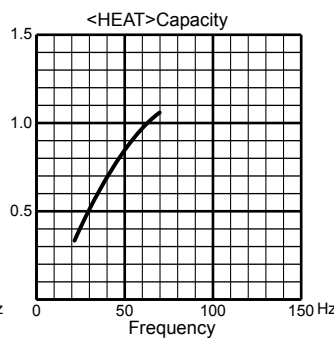
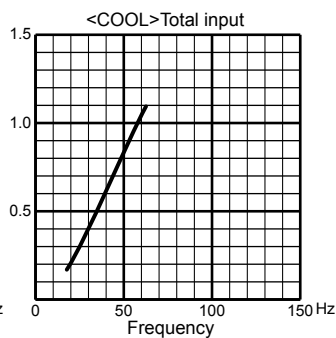
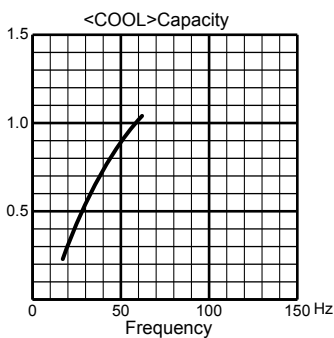

MXZ-5E102VA

15-class unit

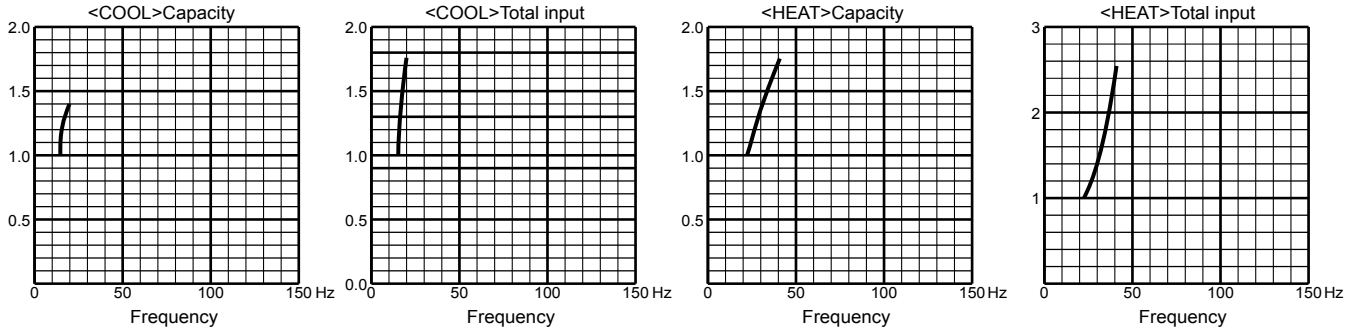

18-class unit

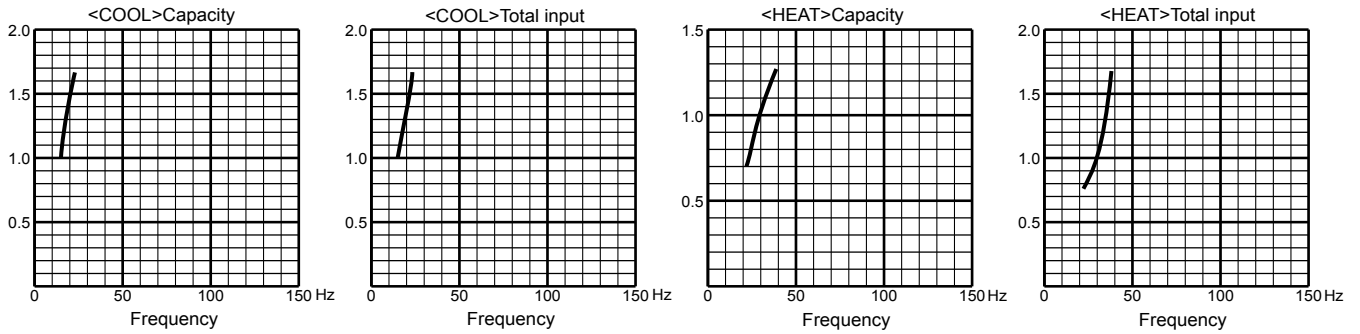

20-class unit

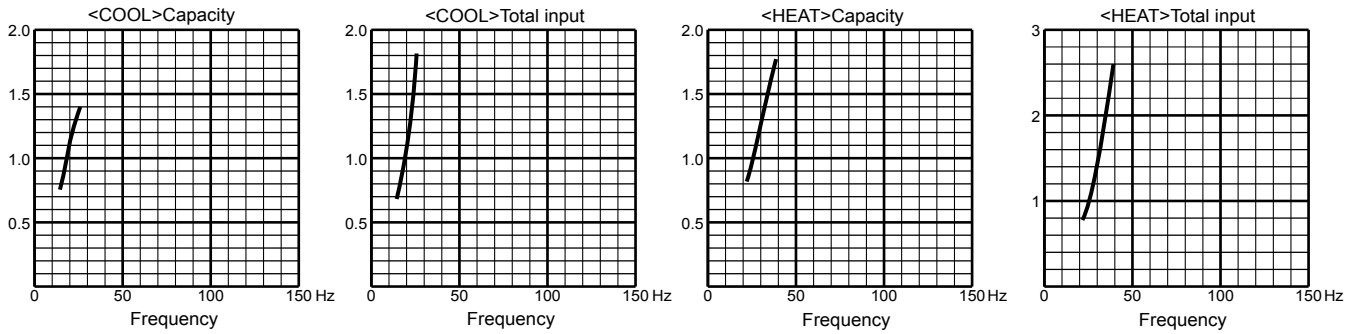

22-class unit

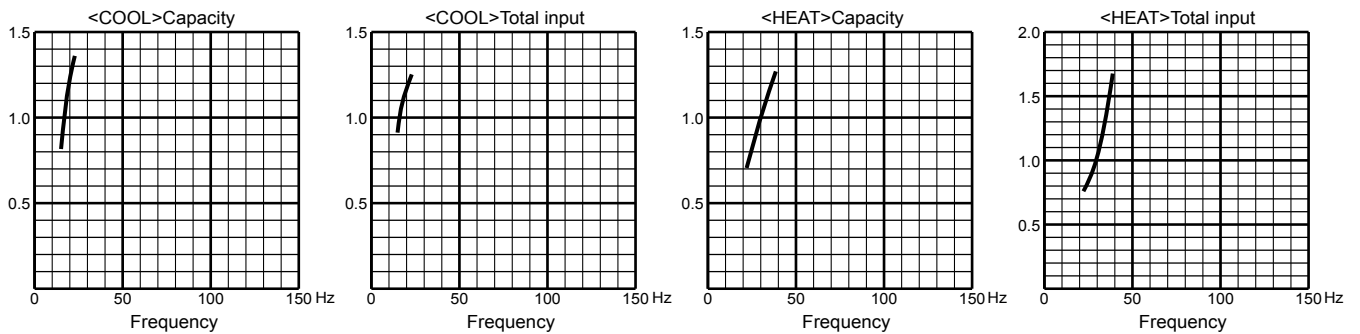

25-class unit

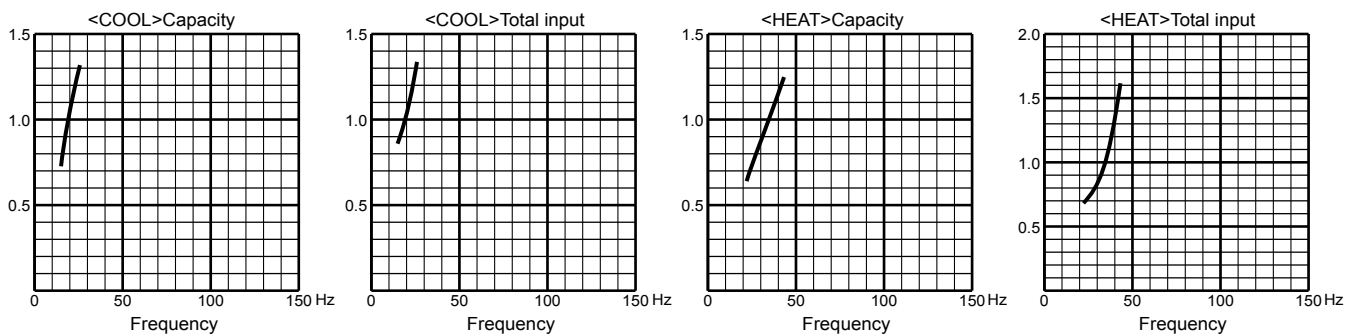

MXZ-5E102VA

35-class unit

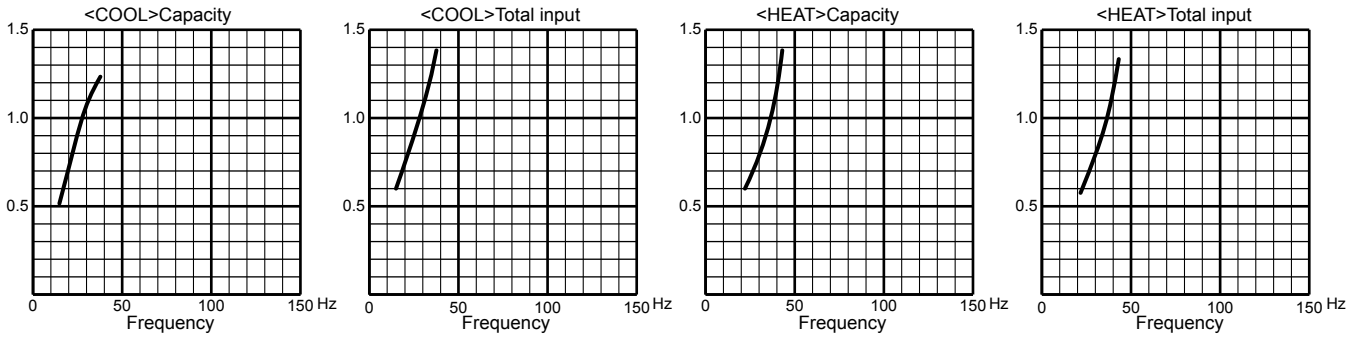

42-class unit

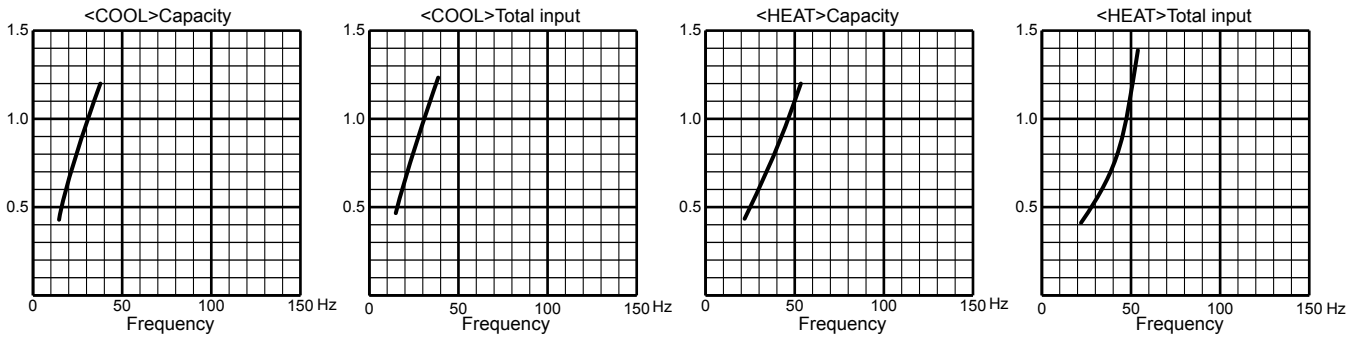

50-class unit

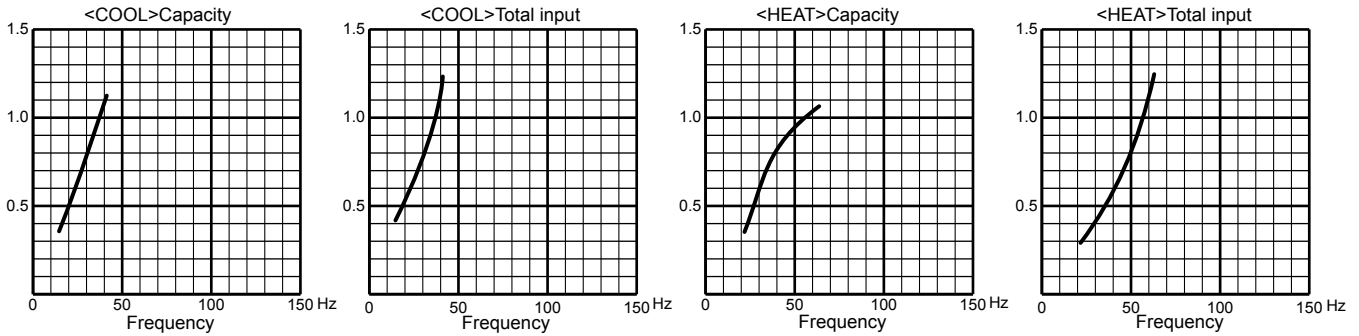

60-class unit

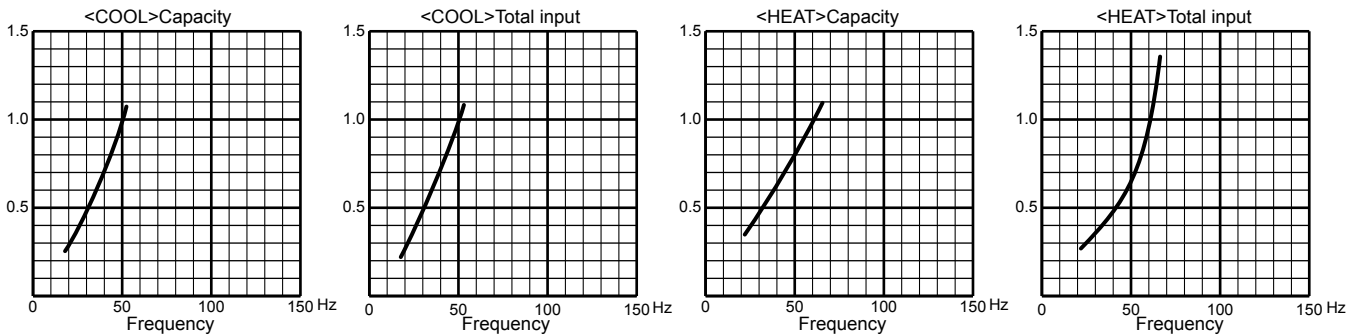

71-class unit

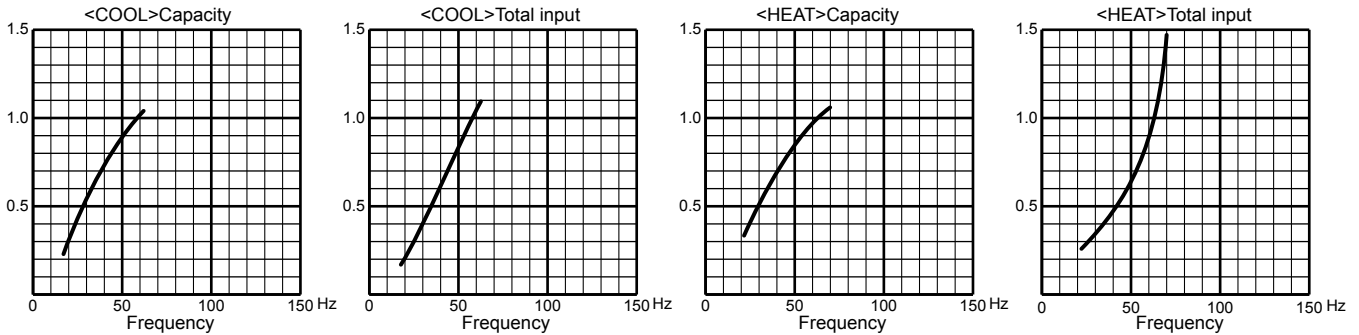

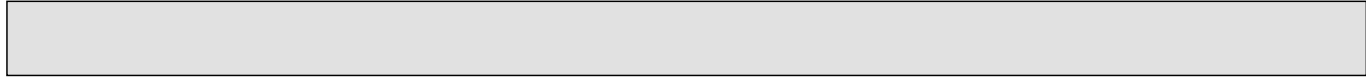

MXZ-2E53VAHZ

15-class unit

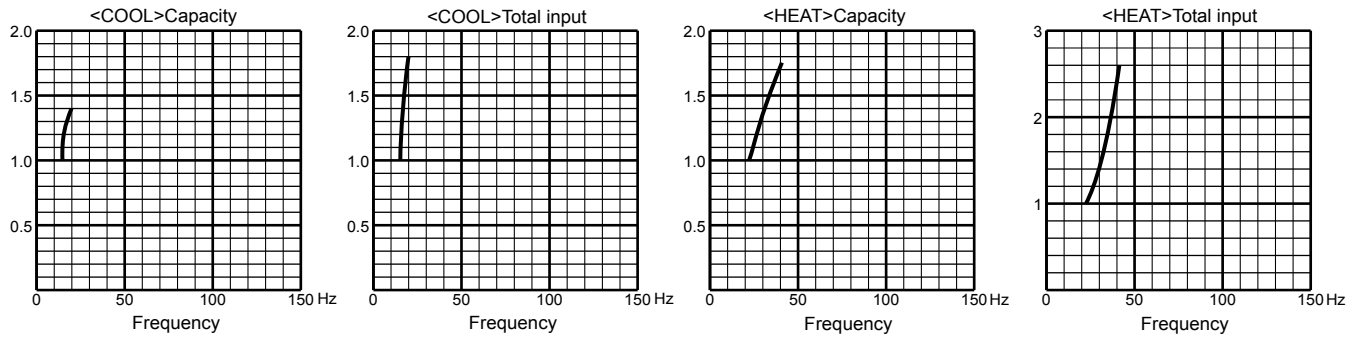

18-class unit

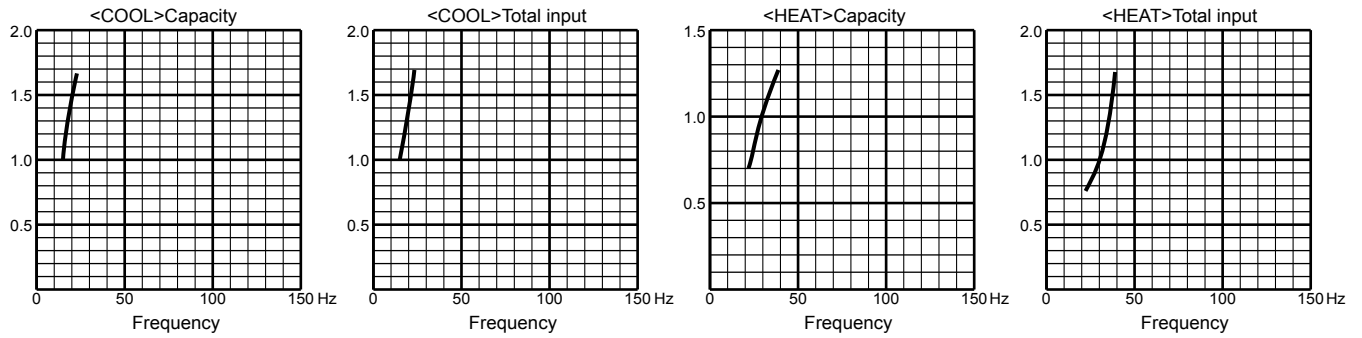

20-class unit

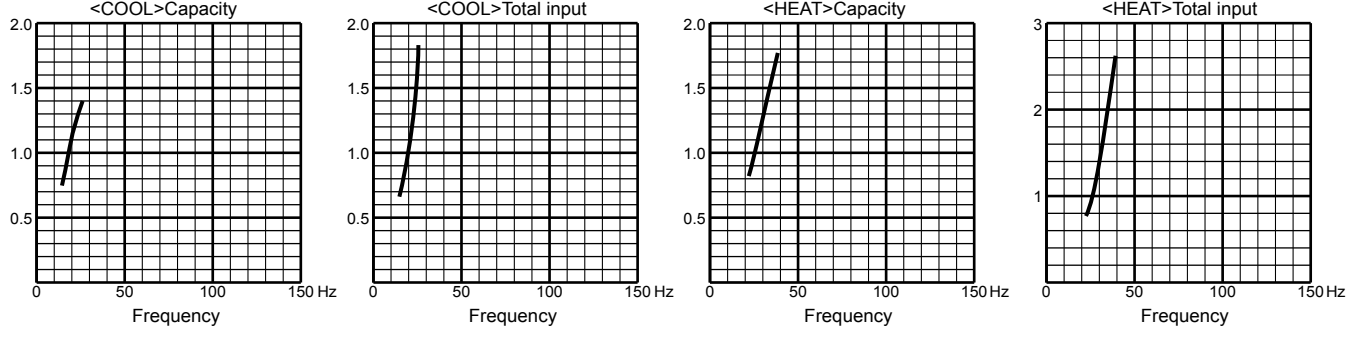

22-class unit

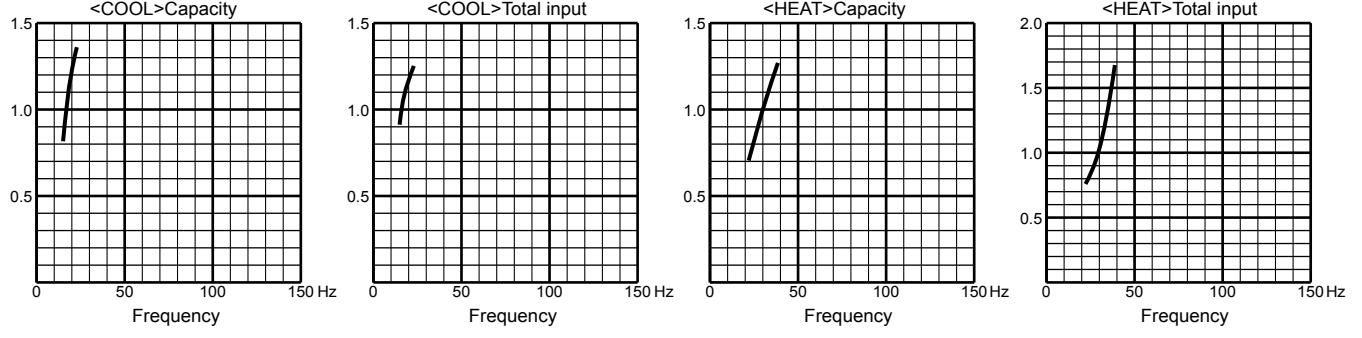

25-class unit

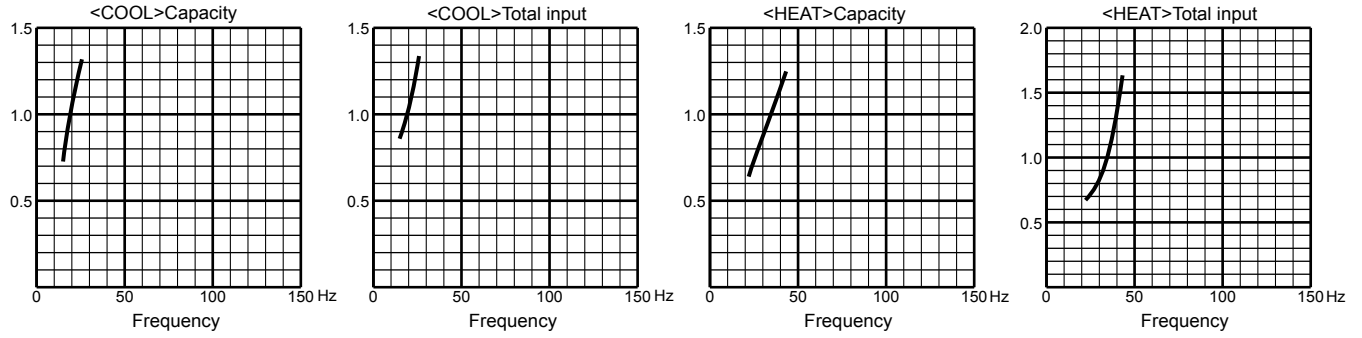

MXZ-2E53VAHZ

35-class unit

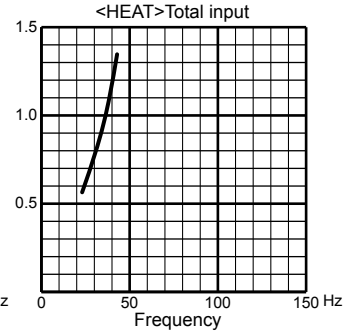
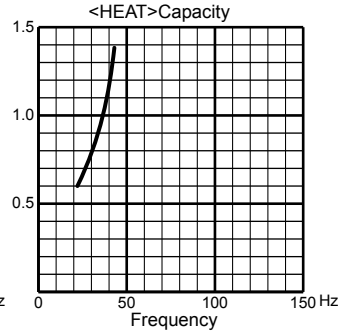
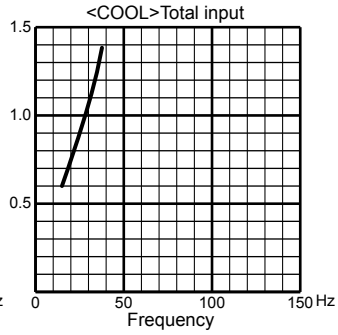
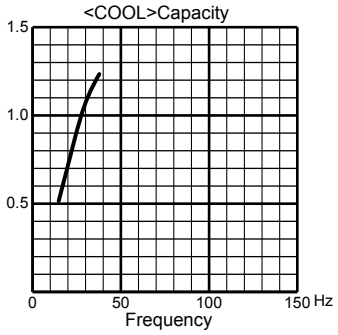

42-class unit

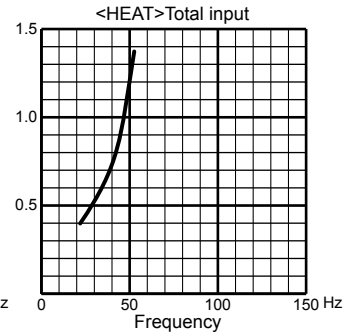
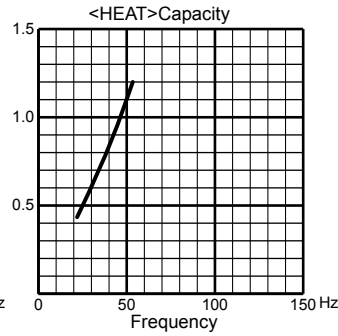
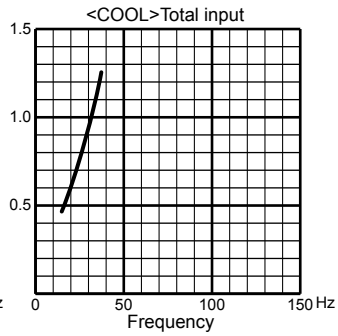
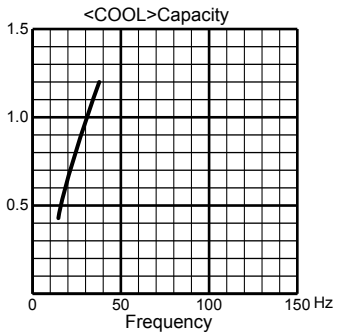

50-class unit

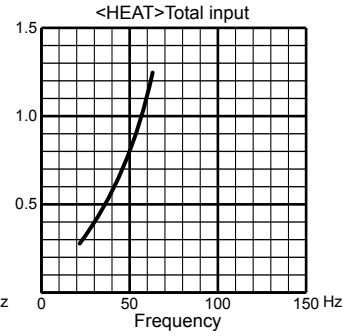
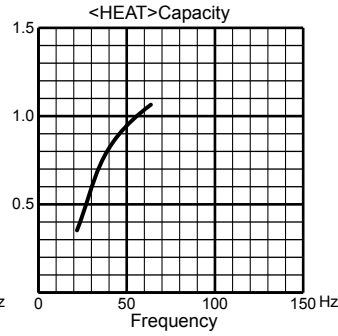
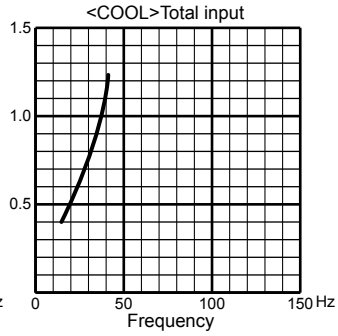
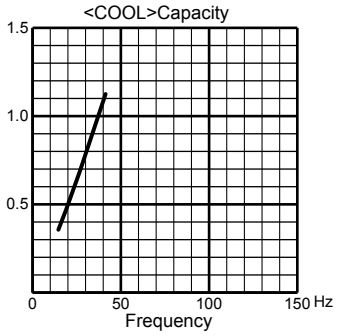

MXZ-4E83VAHZ

15-class unit

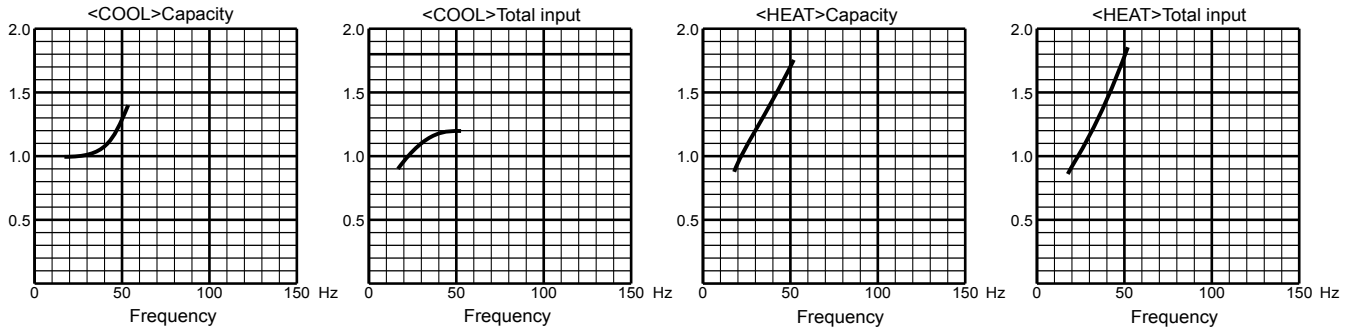

18-class unit

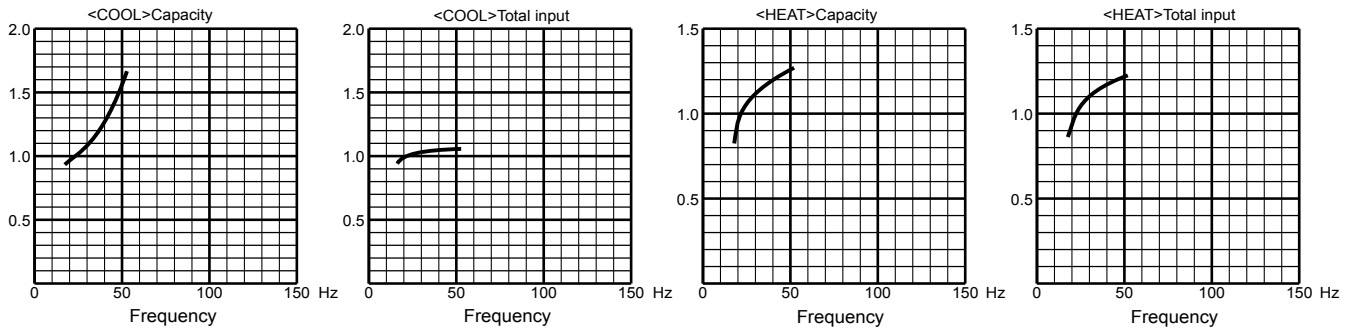

20-class unit

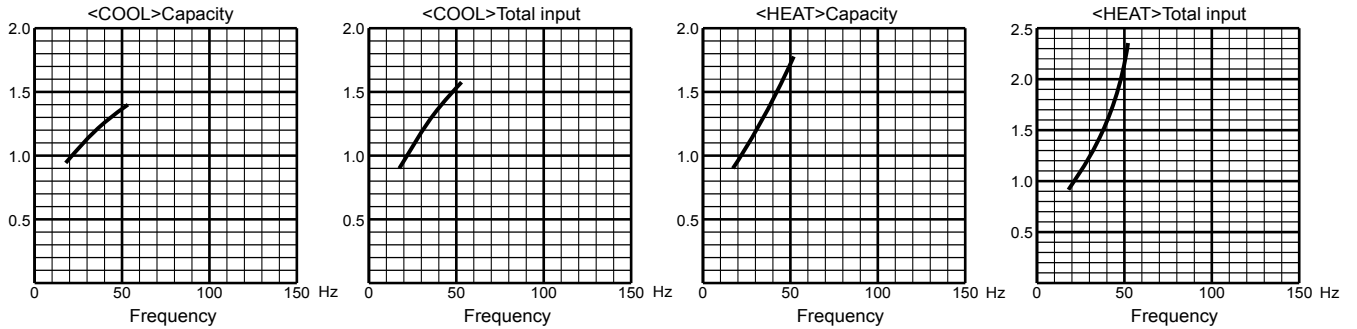

22-class unit

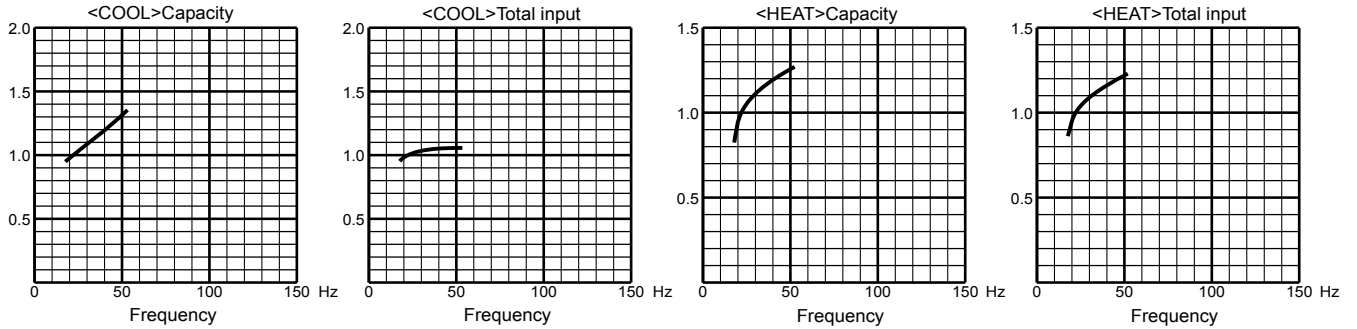

25-class unit

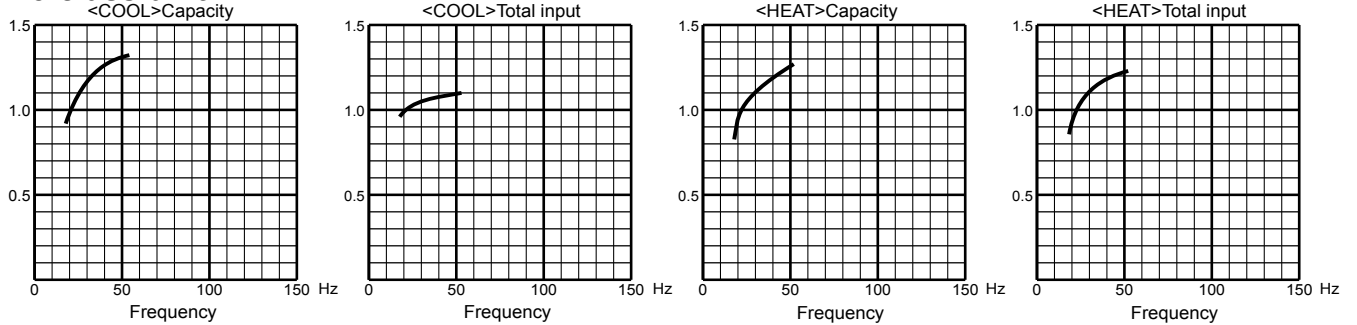

MXZ-4E83VAHZ

35-class unit

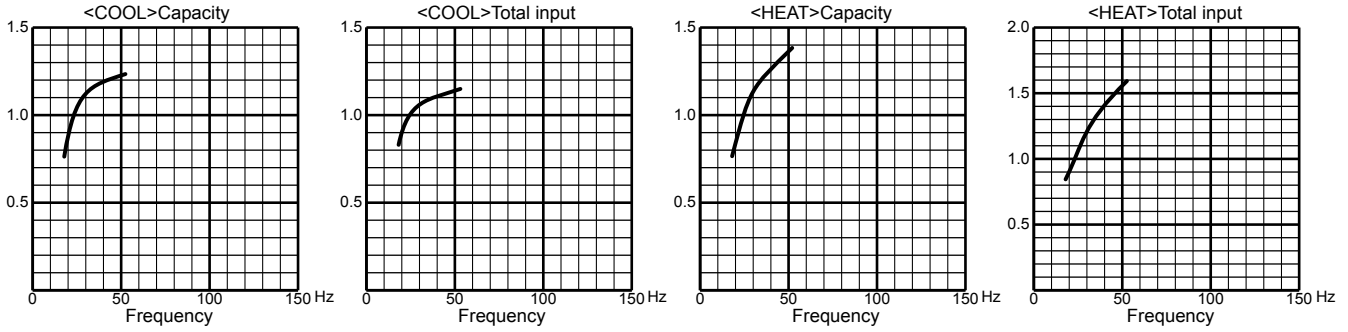

42-class unit

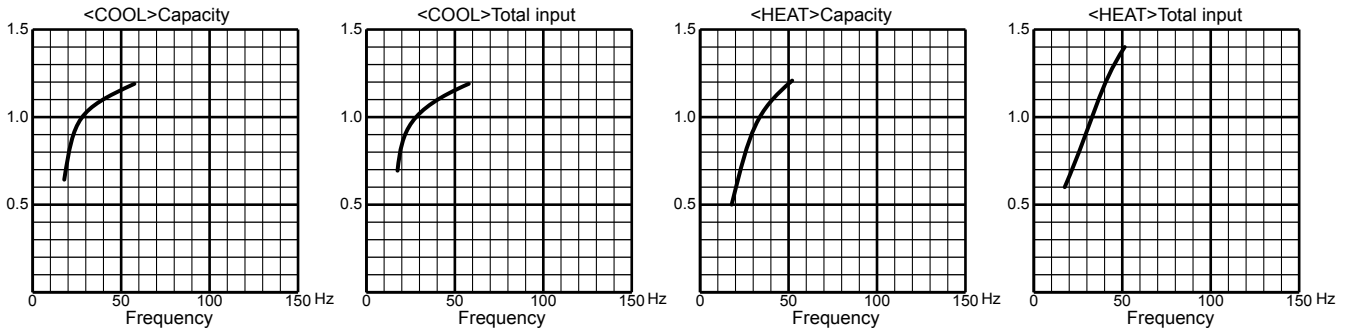

50-class unit

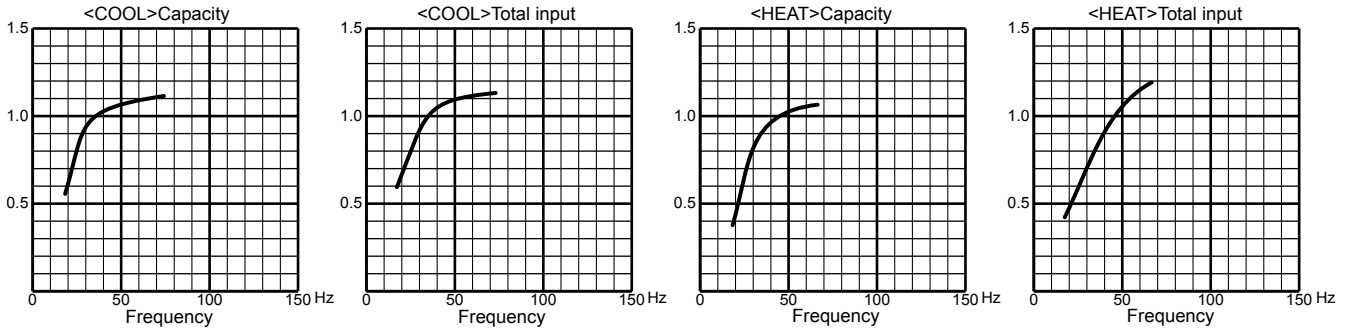

60-class unit

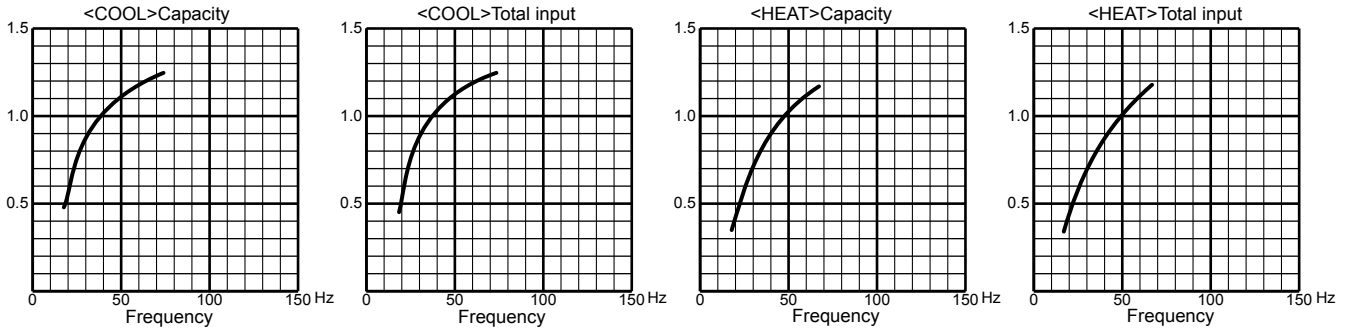

71-class unit

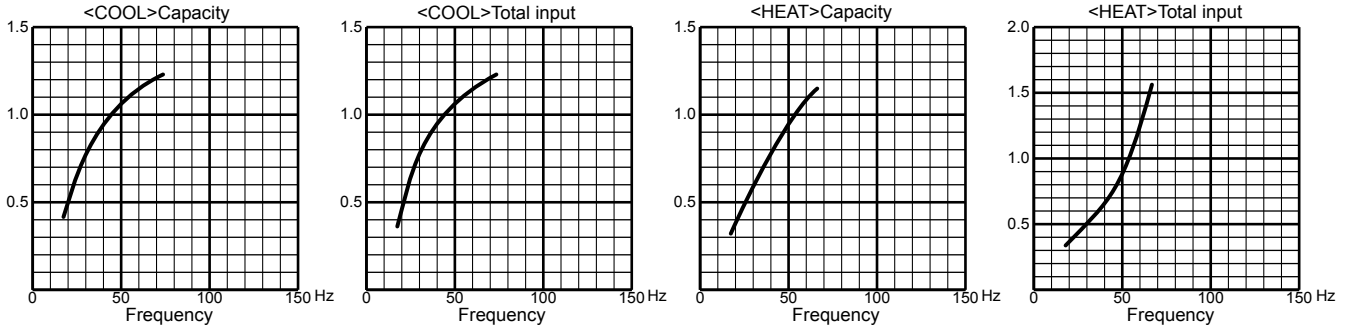

8-3. HOW TO OPERATE FIXED-FREQUENCY OPERATION <Test run operation>

1. Press EMERGENCY OPERATION switch to start COOL or HEAT mode (COOL: Press once, HEAT: Press twice).
2. Test run operation starts and continues to operate for 30 minutes.
3. Compressor operates at rated frequency.
4. Indoor fan operates at High speed.
5. After 30 minutes, test run operation finishes and EMERGENCY OPERATION starts (Operation frequency of compressor varies).
6. To cancel test run operation or EMERGENCY OPERATION, press EMERGENCY OPERATION switch or any button on remote controller.

8-4. OUTDOOR LOW PRESSURE AND OUTDOOR UNIT CURRENT CURVE (single operation)

NOTE: The unit of pressure has been changed to MPa on the international system of units (SI unit system).

The conversion factor is: **1 (MPa [Gauge]) = 10.2 (kgf/cm² [Gauge])**

(1) COOL operation

- ① Both indoor and outdoor units are under the same temperature/humidity condition.
- ② Operation: TEST RUN OPERATION (Refer to 8-3.)

Dry-bulb temperature (°C)	Relative humidity (%)
20	50
25	60
30	70

MXZ-3E54VA

15-class unit

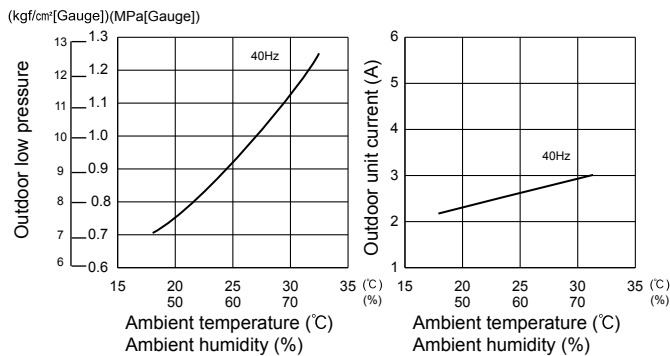

18-class unit

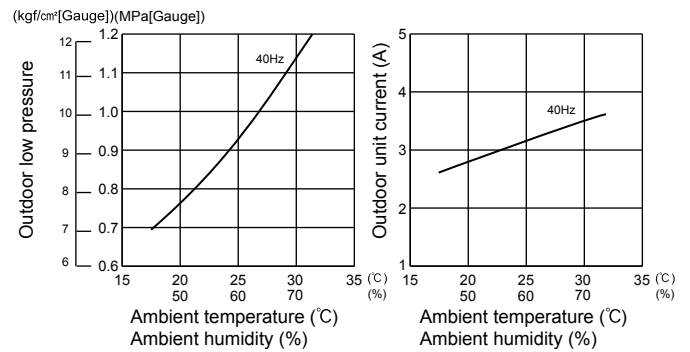

20-class unit

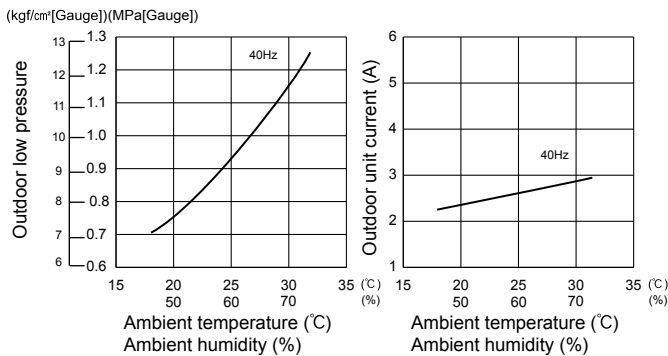

22-class unit

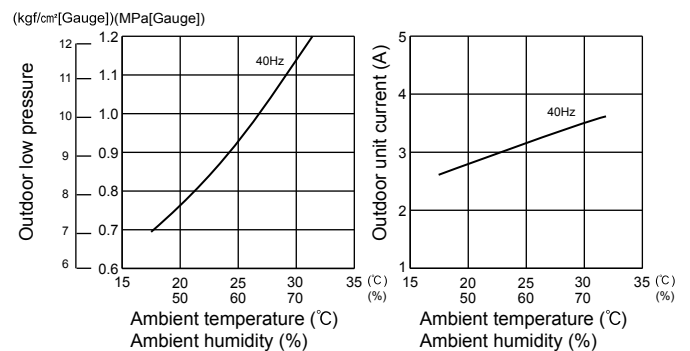

MXZ-3E54VA

25-class unit

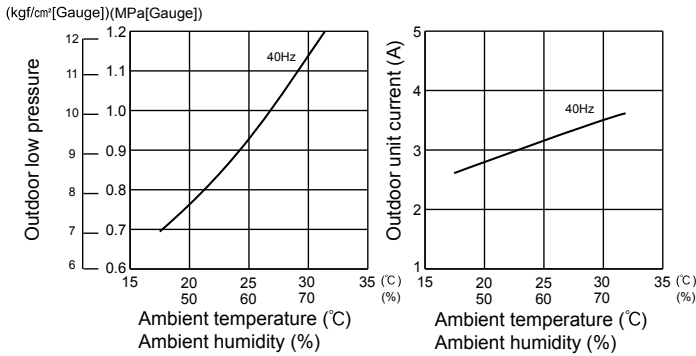

35-class unit

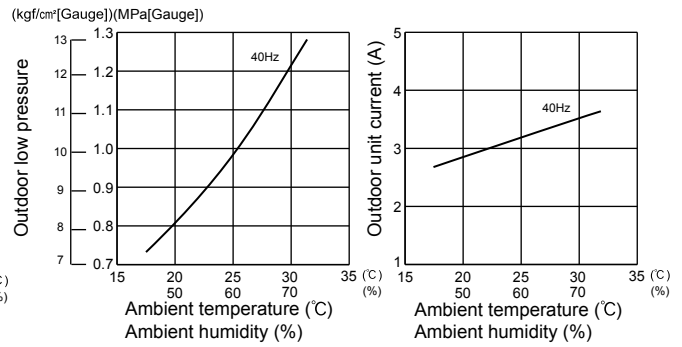

42-class unit

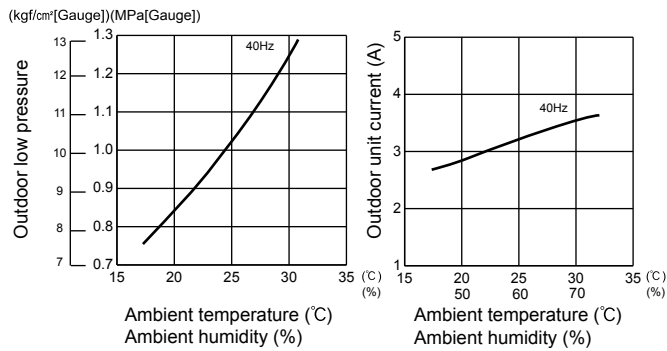

50-class unit

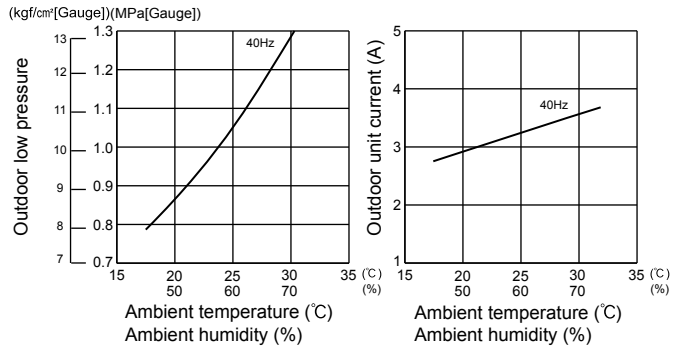

MXZ-3E68VA MXZ-4E72VA

15-class unit

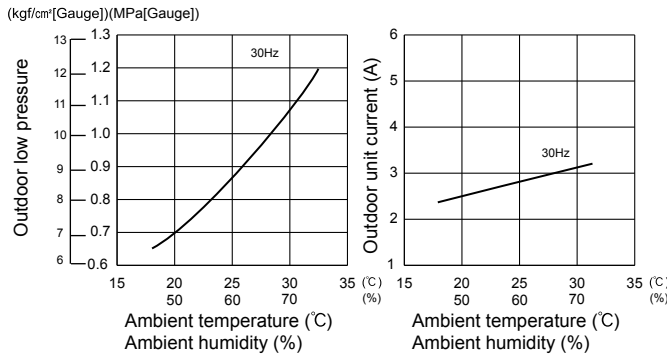

18-class unit

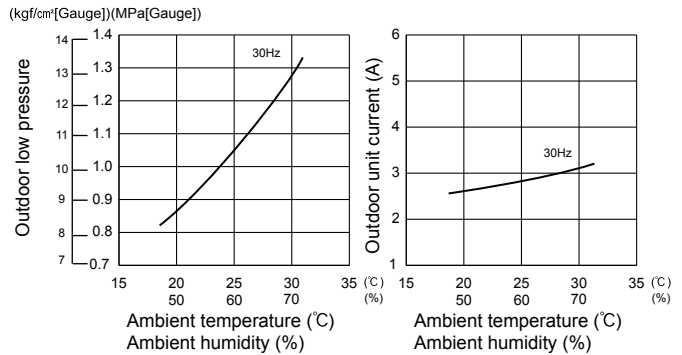

20-class unit

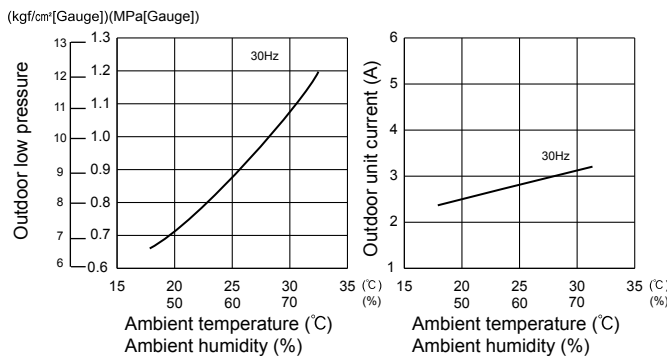

22-class unit

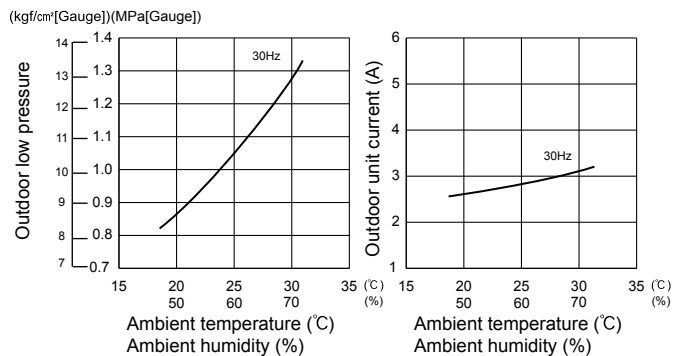

MXZ-3E68VA MXZ-4E72VA

25-class unit

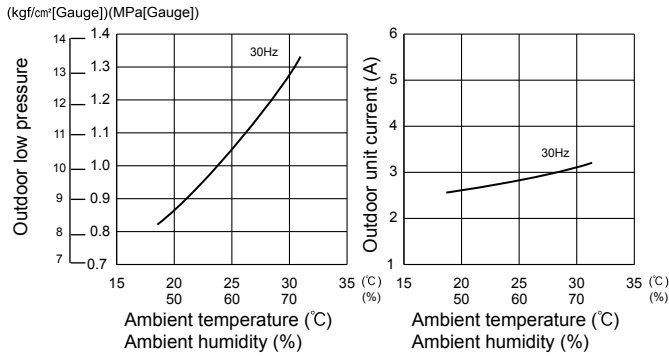

35-class unit

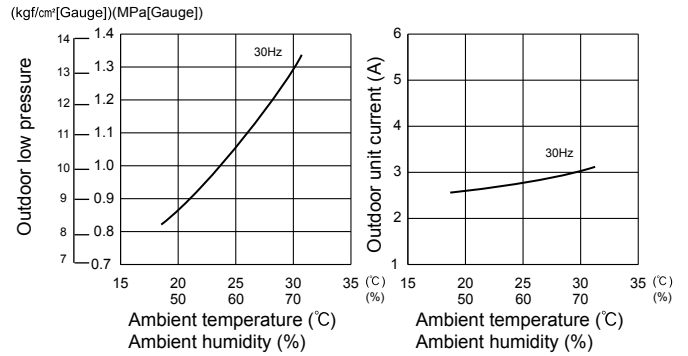

42-class unit

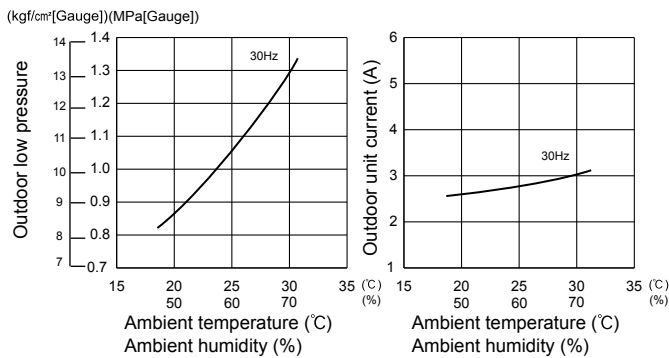

50-class unit

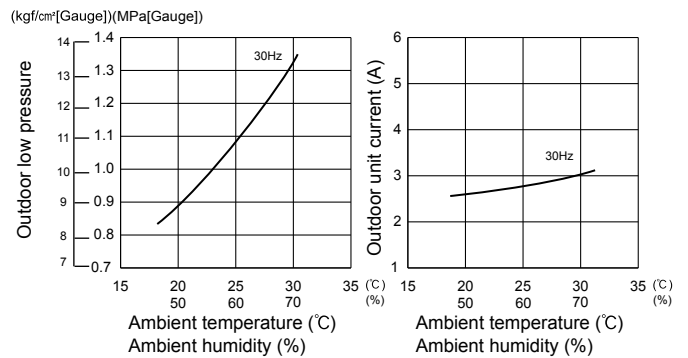

60-class unit

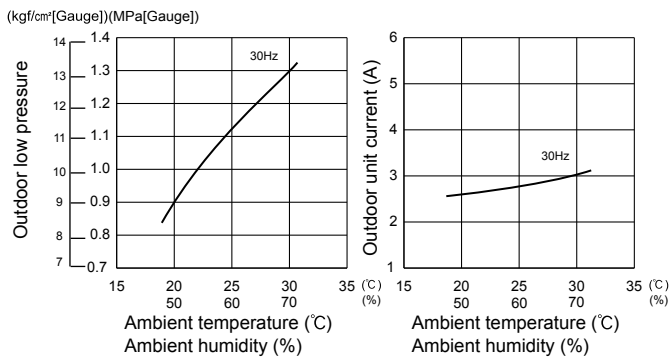

MXZ-4E83VA

15-class unit

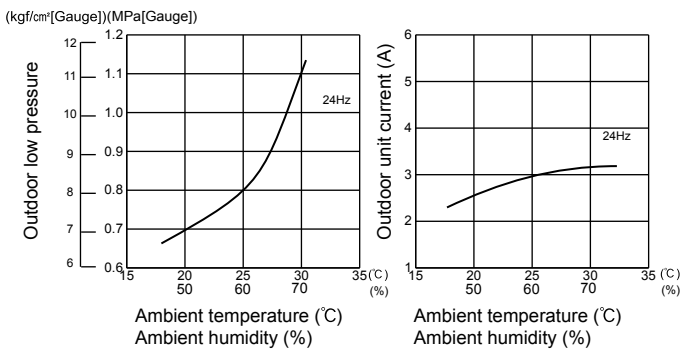

18-class unit

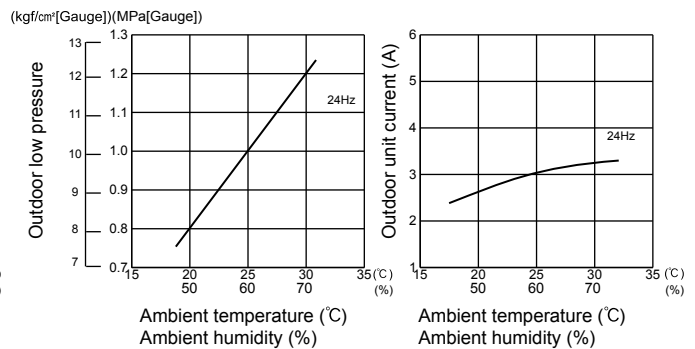

MXZ-4E83VA

20-class unit

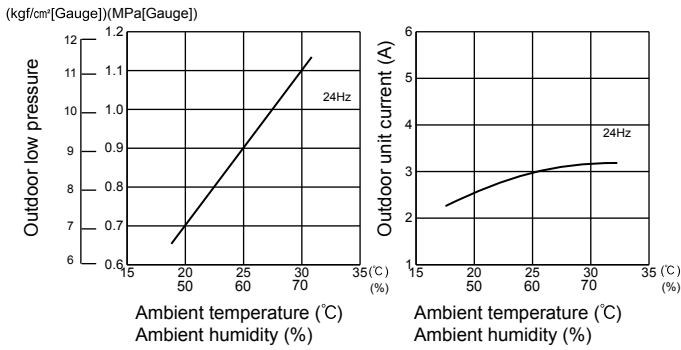

22-class unit

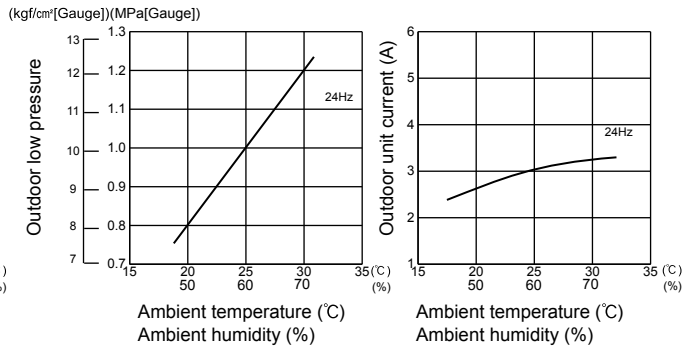

25-class unit

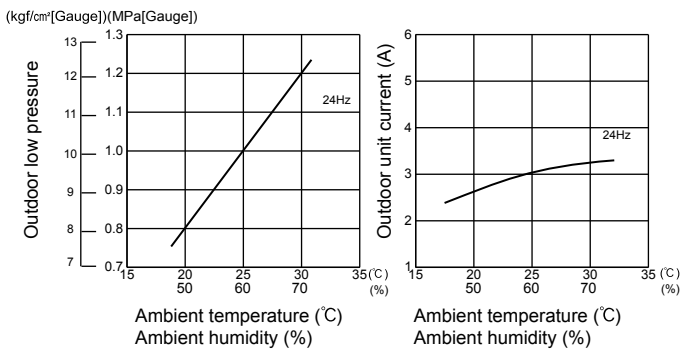

35-class unit

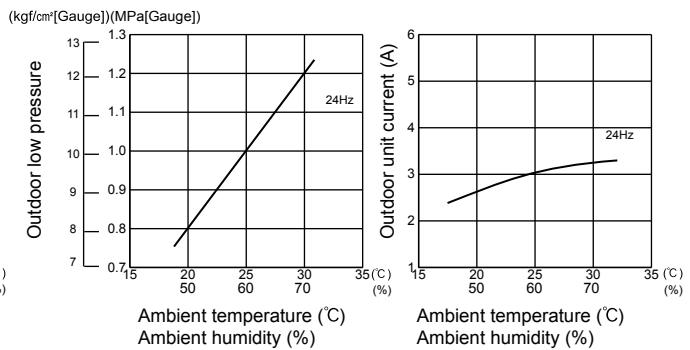

42-class unit

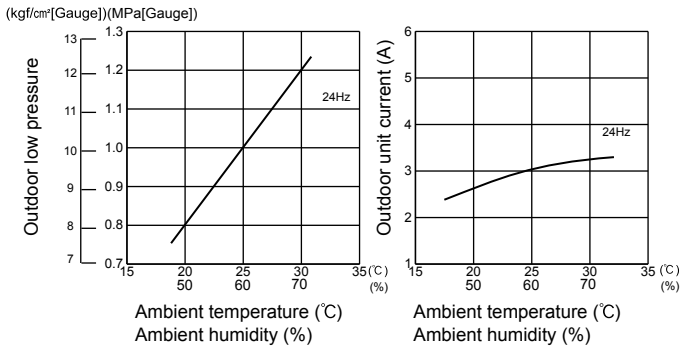

50-class unit

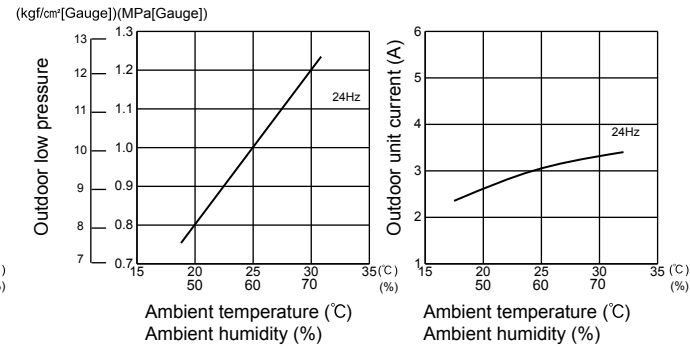

60-class unit

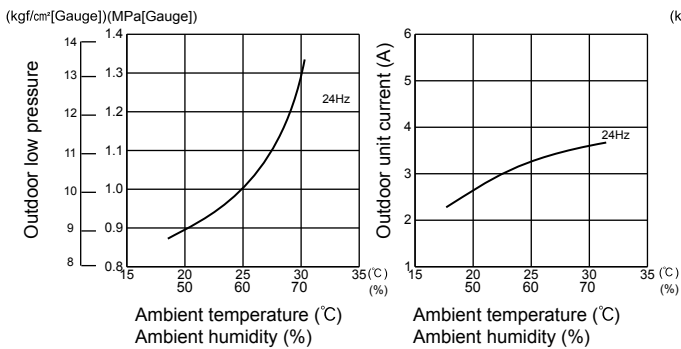

71-class unit

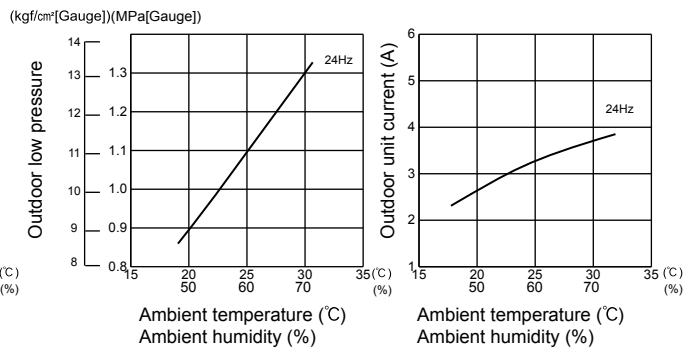

MXZ-5E102VA

15-class unit

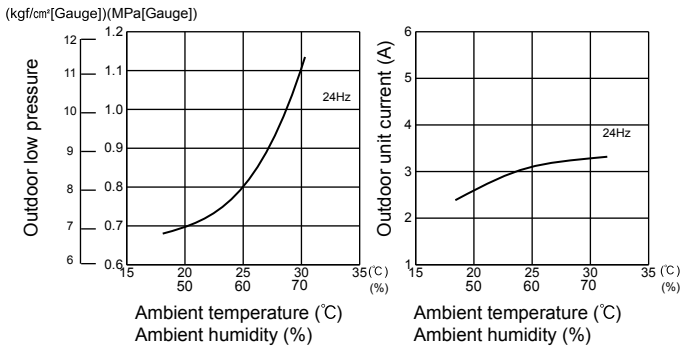

18-class unit

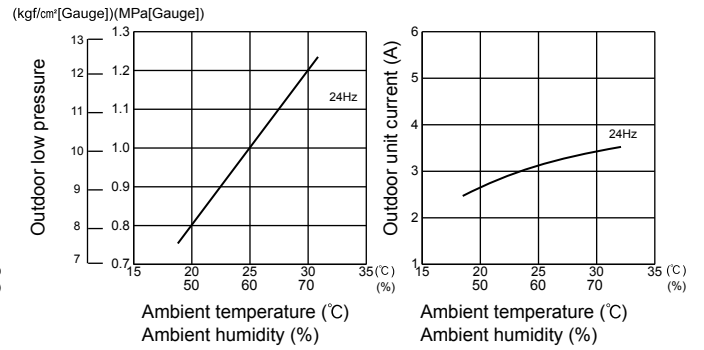

20-class unit

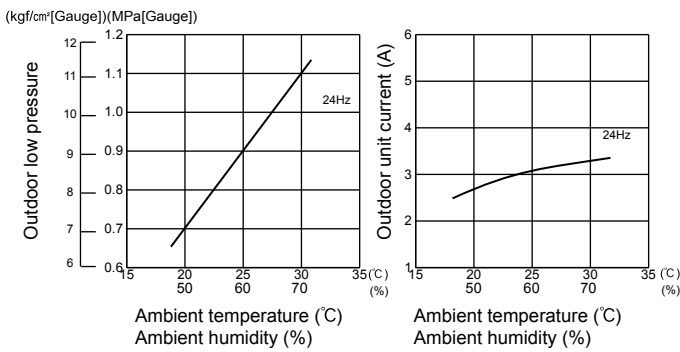

22-class unit

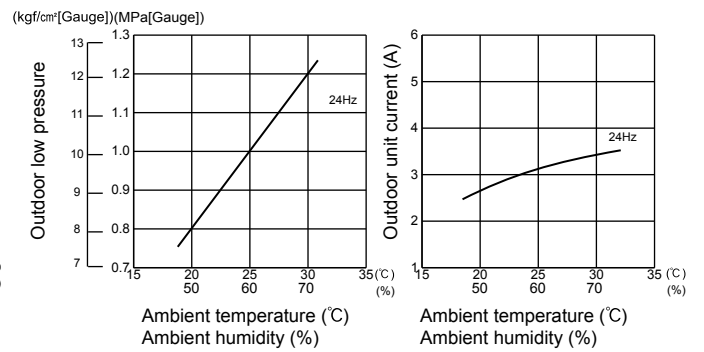

25-class unit

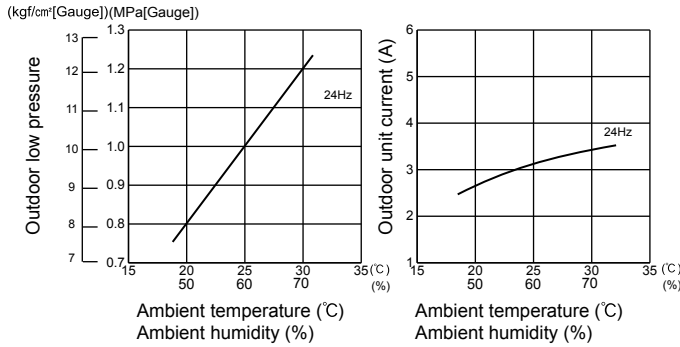

35-class unit

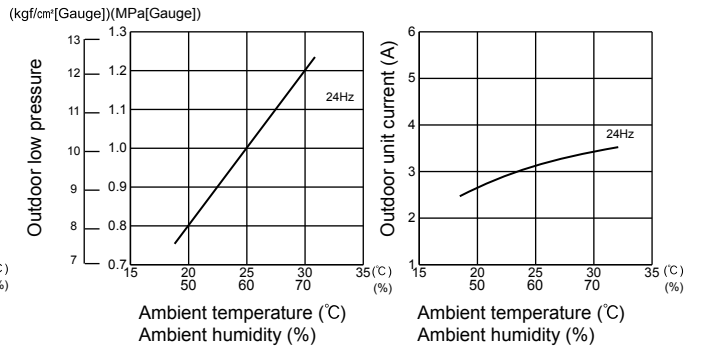

42-class unit

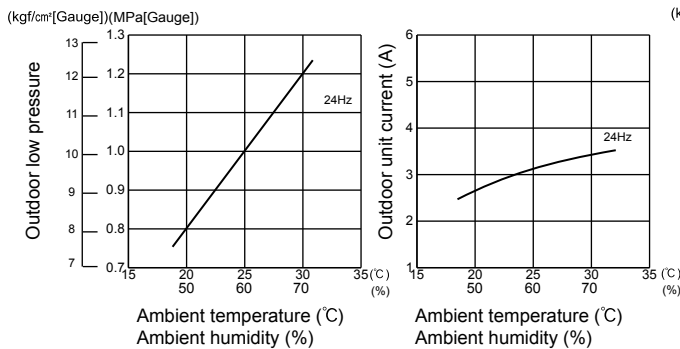

50-class unit

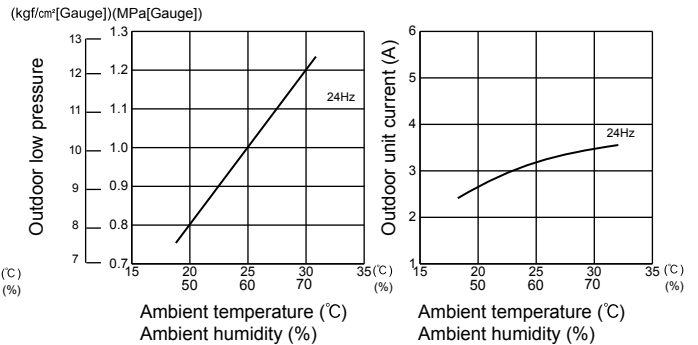

MXZ-5E102VA

60-class unit

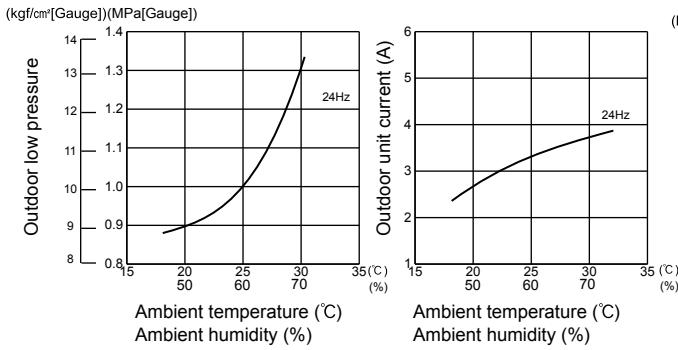

71-class unit

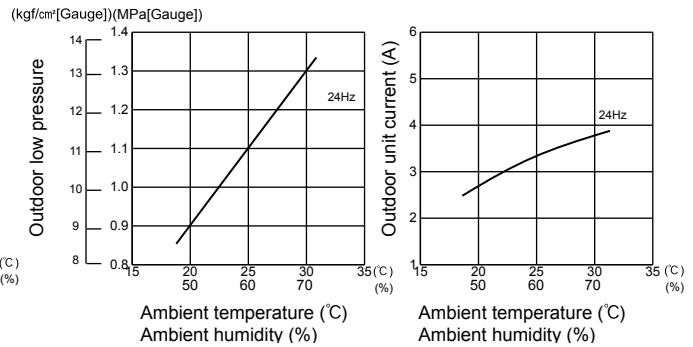

MXZ-2E53VAHZ

15-class unit

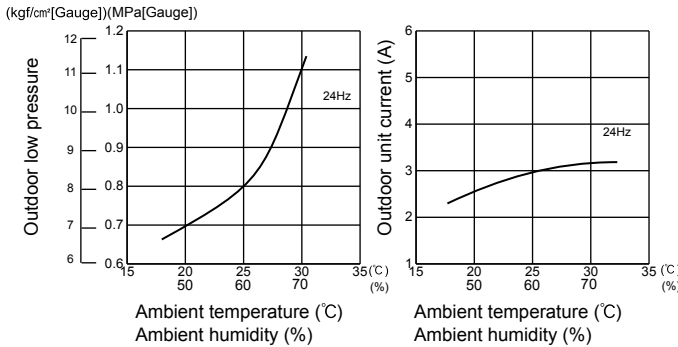

18-class unit

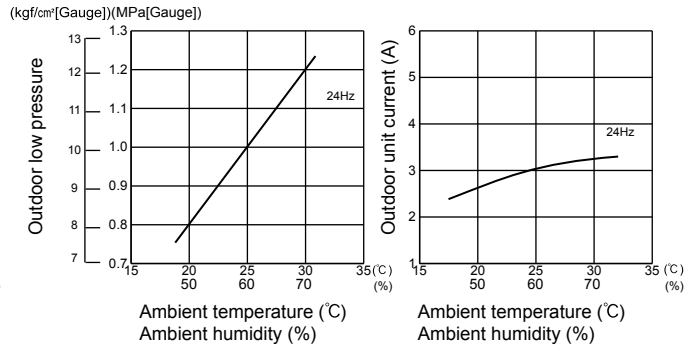

20-class unit

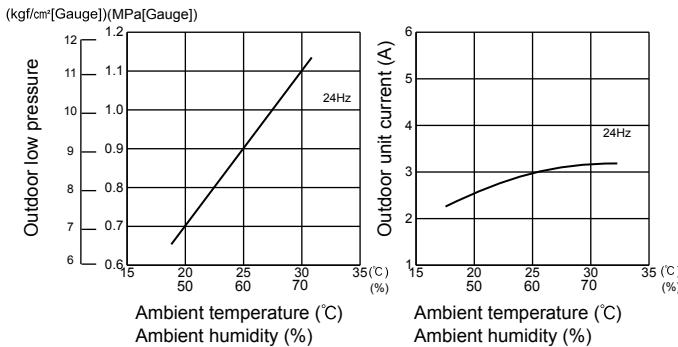

22-class unit

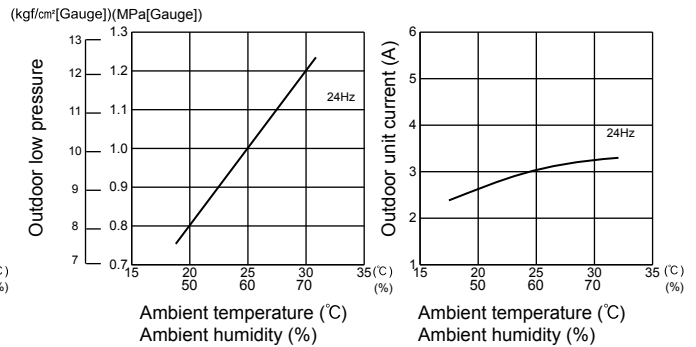

25-class unit

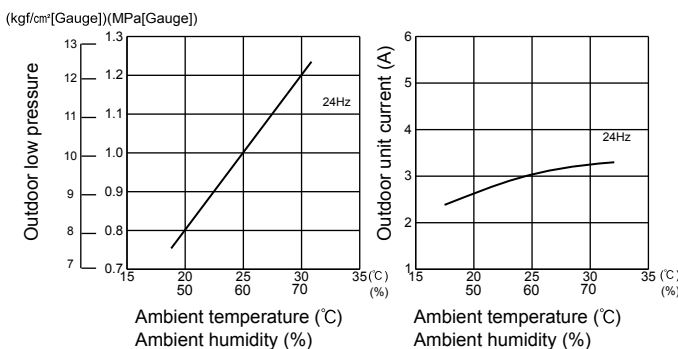

35-class unit

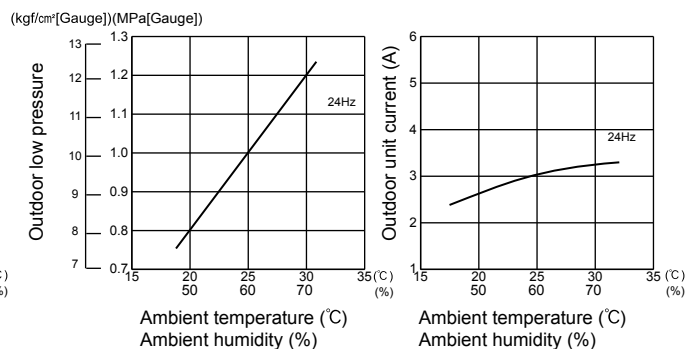

MXZ-2E53VAHZ

42-class unit

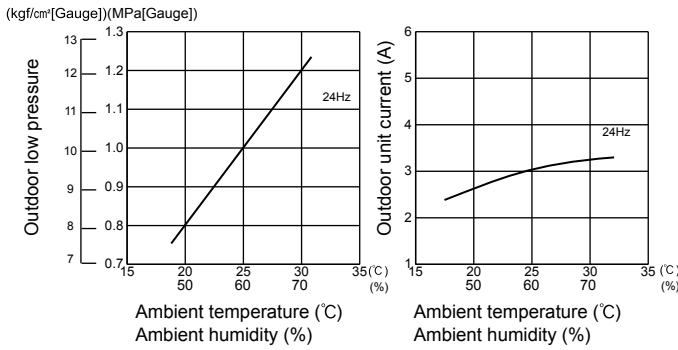

50-class unit

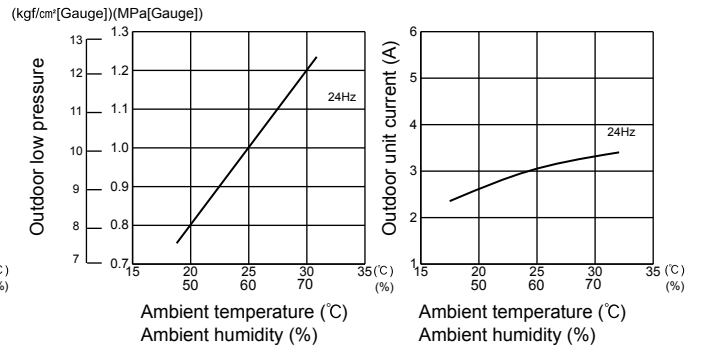

MXZ-4E83VAHZ

15-class unit

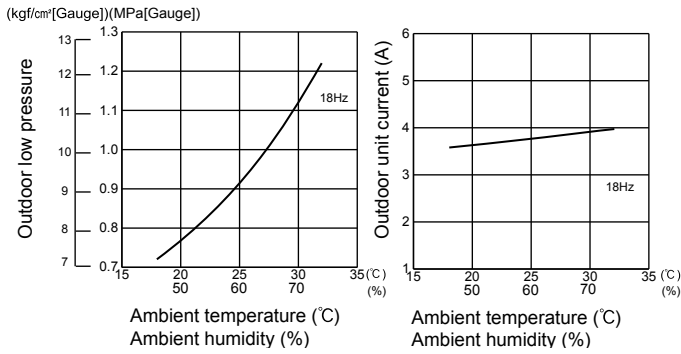

18-class unit

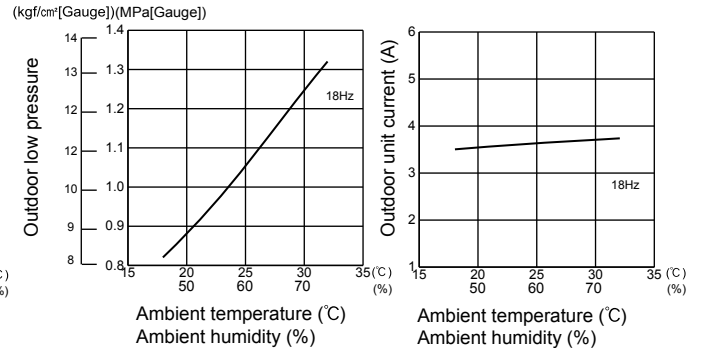

20-class unit

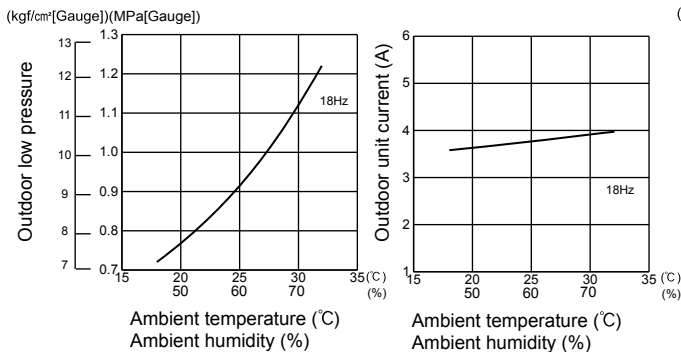

22-class unit

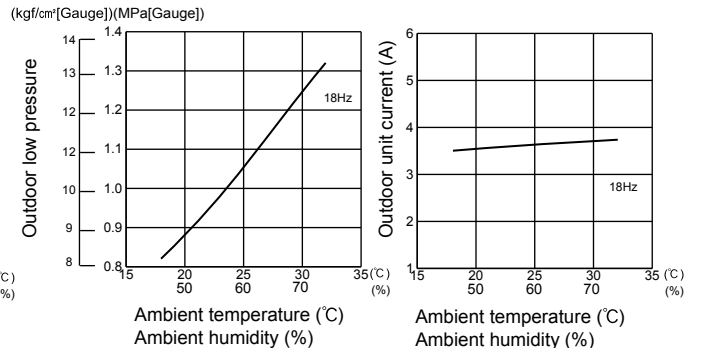

25-class unit

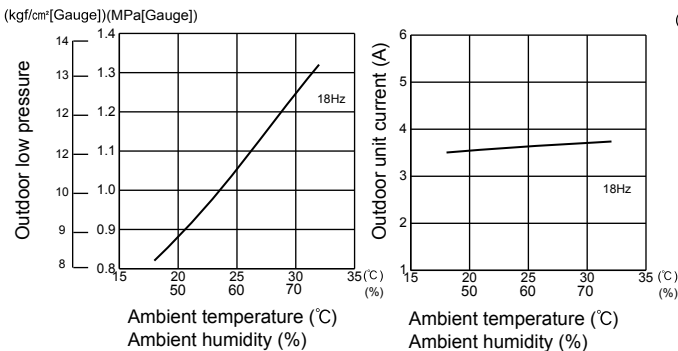

35-class unit

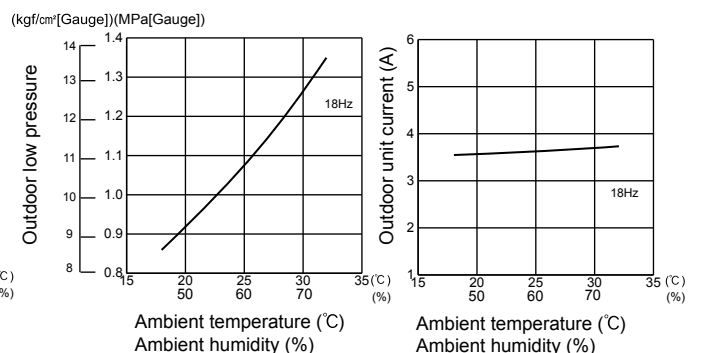

MXZ-4E83VAHZ

42-class unit

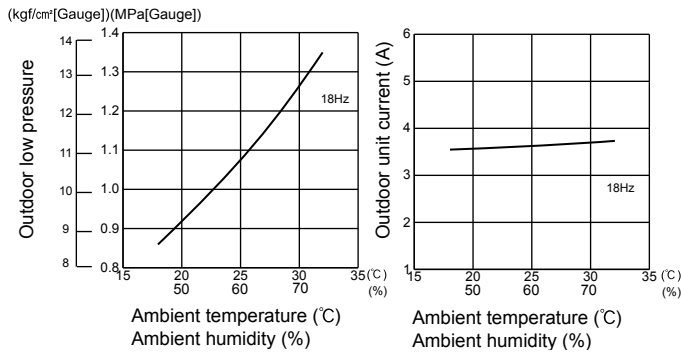

50-class unit

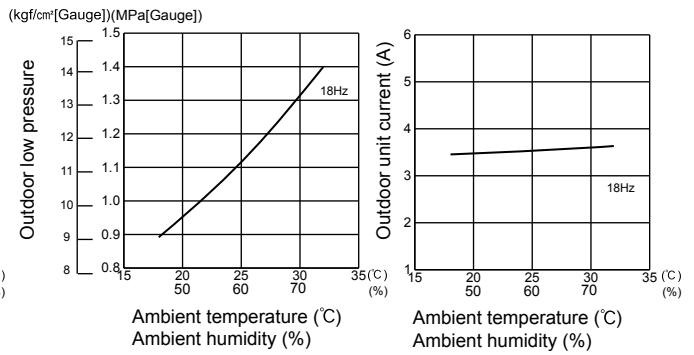

60-class unit

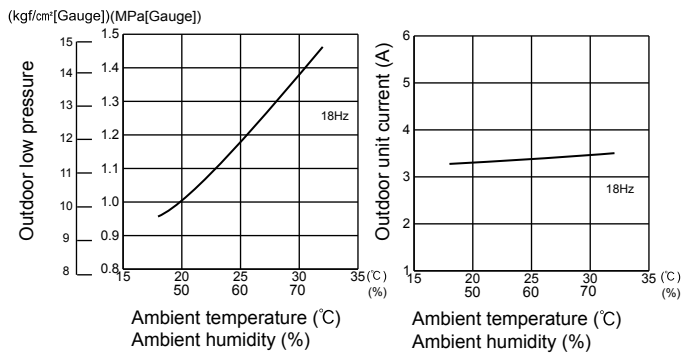

71-class unit

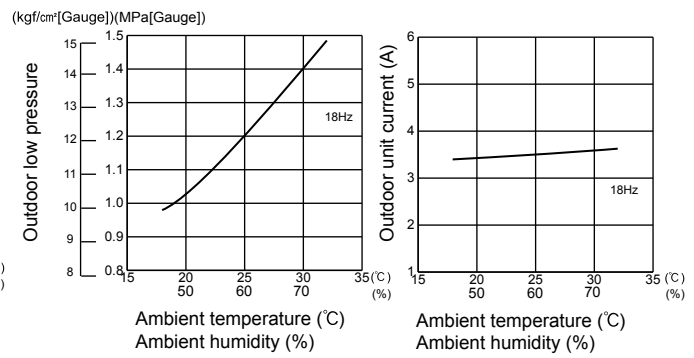

(2) HEAT operation

① Condition:

	Indoor	Outdoor			
Dry bulb temperature (°C)	20.0	2	7	15	20.0
Wet bulb temperature (°C)	14.5	1	6	12	14.5

② Operation: TEST RUN OPERATION (Refer to 8-3.)

MXZ-3E54VA

15-class unit

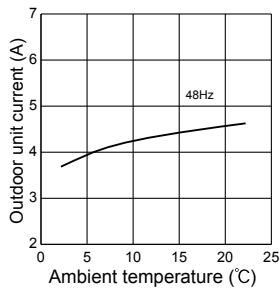

18-class unit

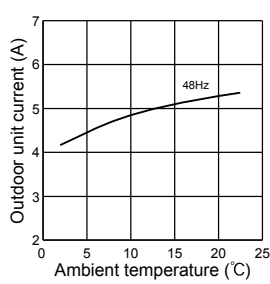

20-class unit

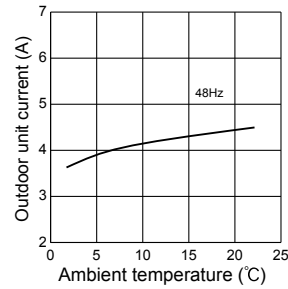

22-class unit

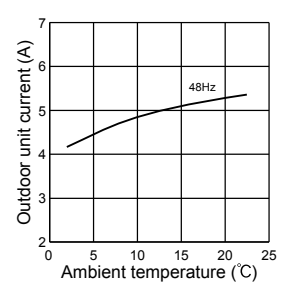

25-class unit

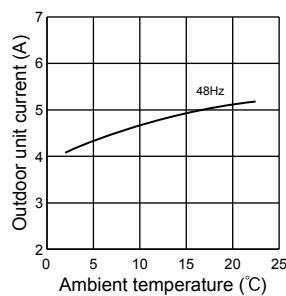

35-class unit

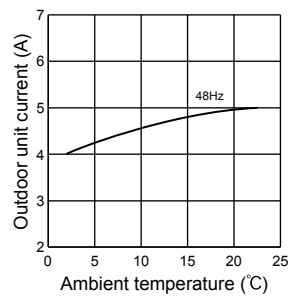

42-class unit

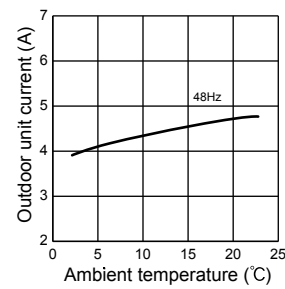

50-class unit

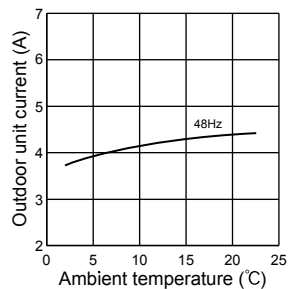

MXZ-3E68VA MXZ-4E72VA

15-class unit

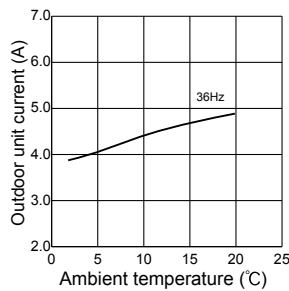

18-class unit

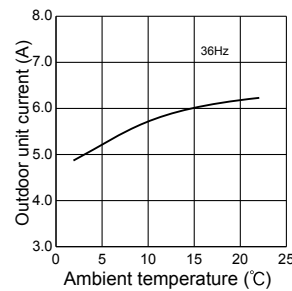

20-class unit

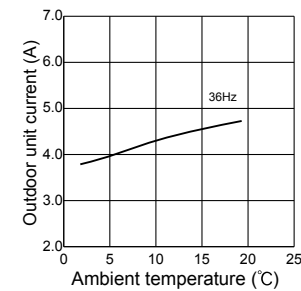

22-class unit

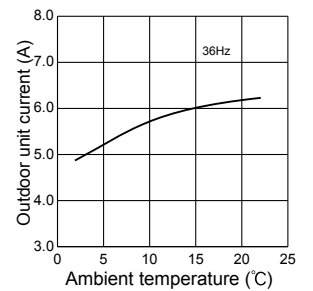

25-class unit

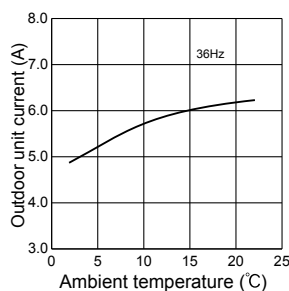

35-class unit

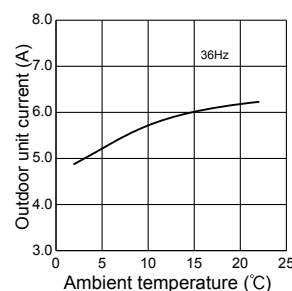

42-class unit

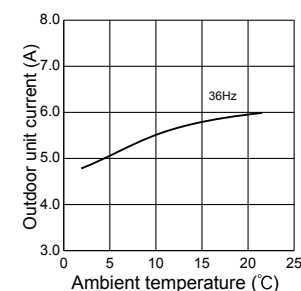

50-class unit

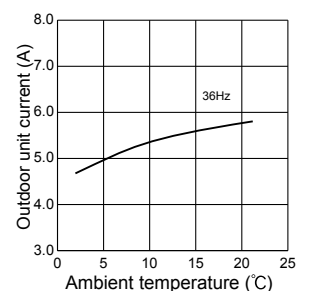

MXZ-3E68VA MXZ-4E72VA

60-class unit

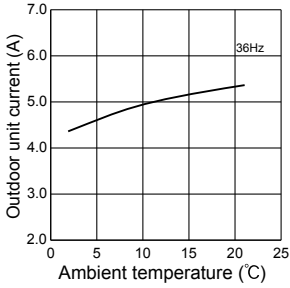

MXZ-4E83VA

15-class unit

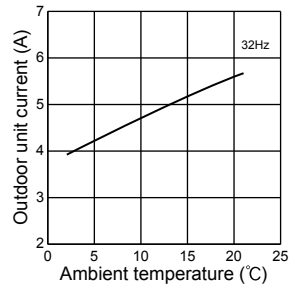

18-class unit

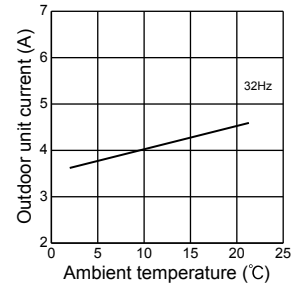

20-class unit

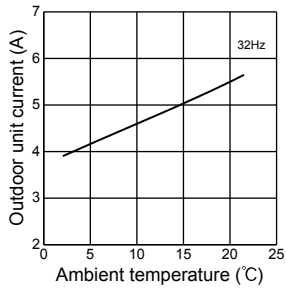

22-class unit

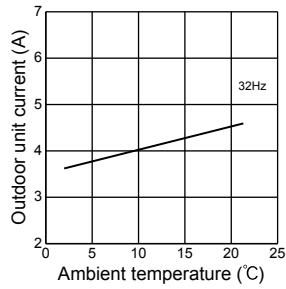

25-class unit

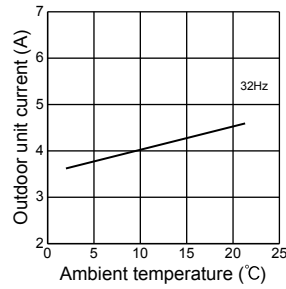

35-class unit

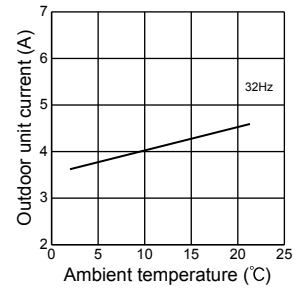

42-class unit

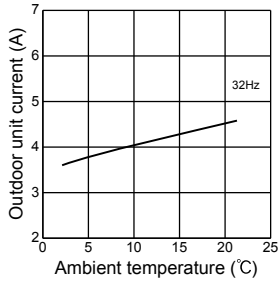

50-class unit

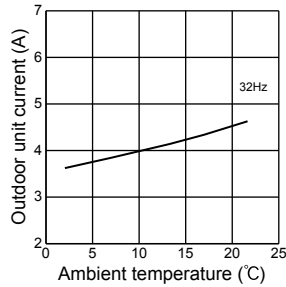

60-class unit

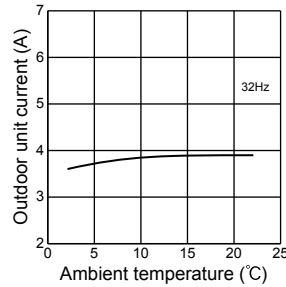

71-class unit

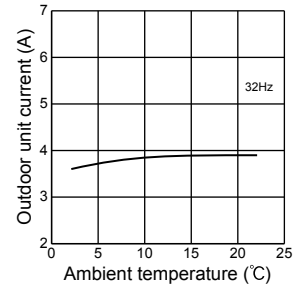

MXZ-5E102VA

15-class unit

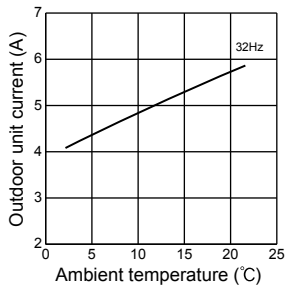

18-class unit

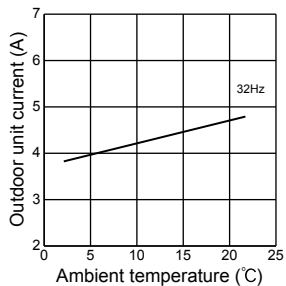

20-class unit

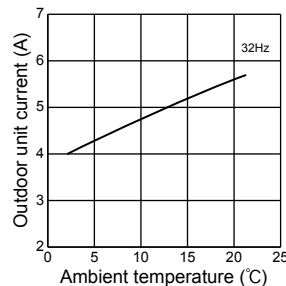

22-class unit

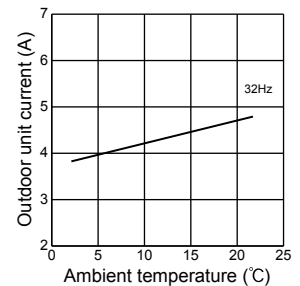

25-class unit

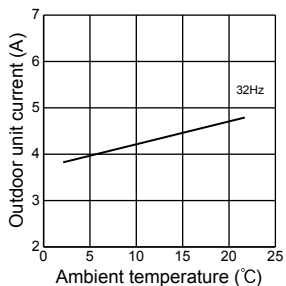

35-class unit

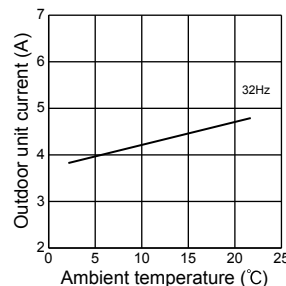

42-class unit

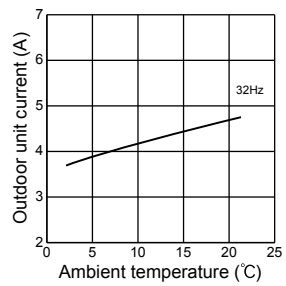

50-class unit

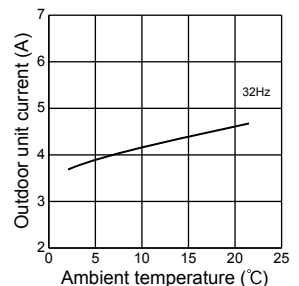

MXZ-5E102VA

60-class unit

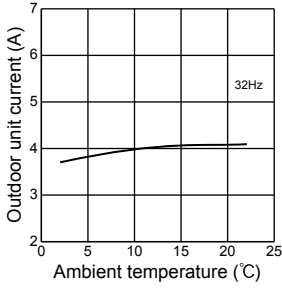

71-class unit

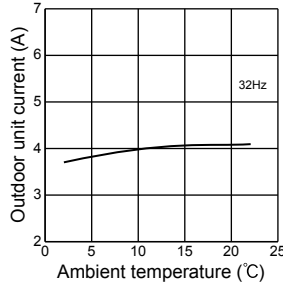

MXZ-2E53VAHZ

15-class unit

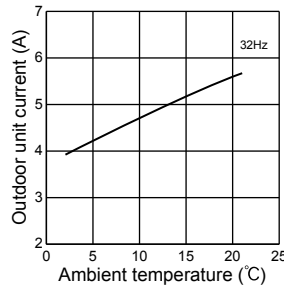

18-class unit

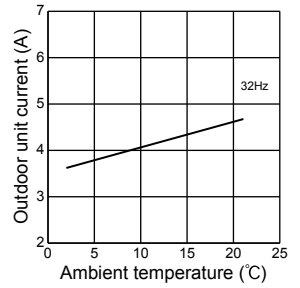

20-class unit

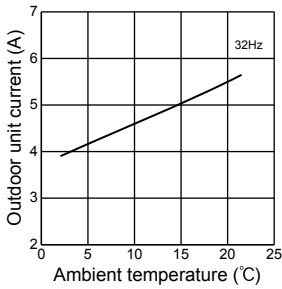

22-class unit

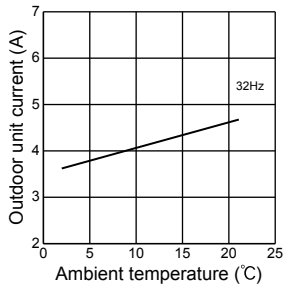

25-class unit

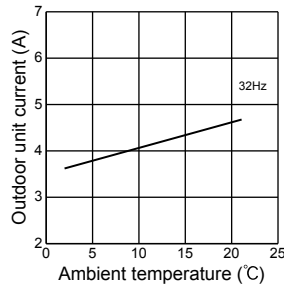

35-class unit

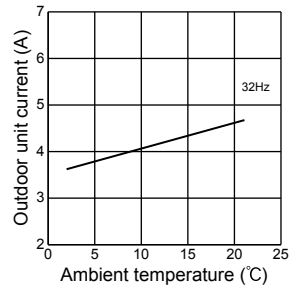

42-class unit

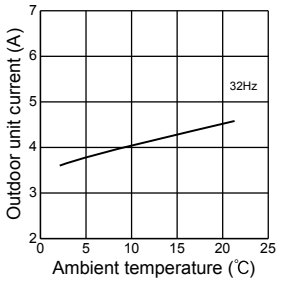

50-class unit

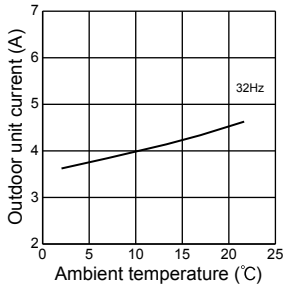

MXZ-4E83VAHZ

15-class unit

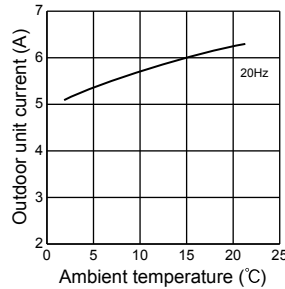

18-class unit

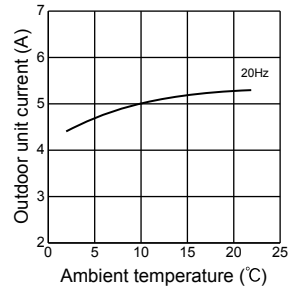

20-class unit

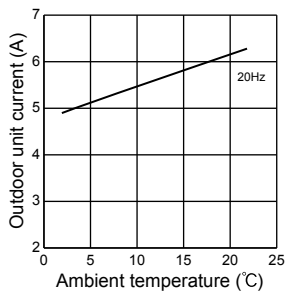

22-class unit

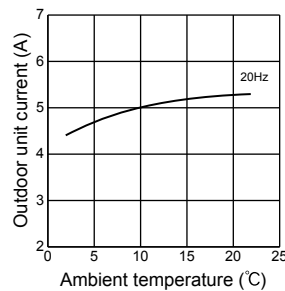

25-class unit

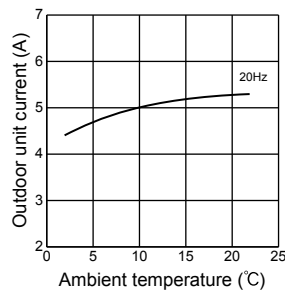

35-class unit

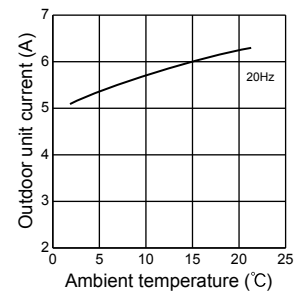

42-class unit

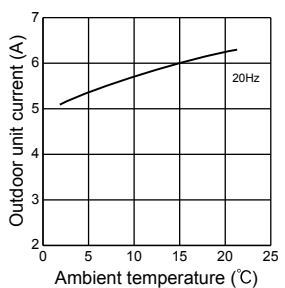

50-class unit

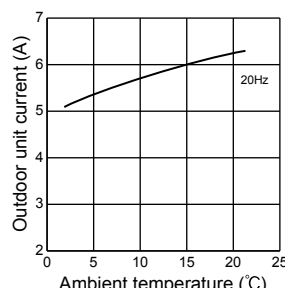

60-class unit

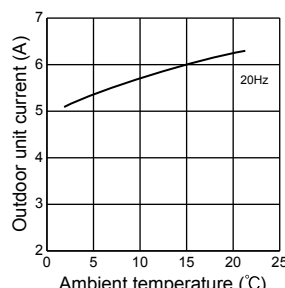

71-class unit

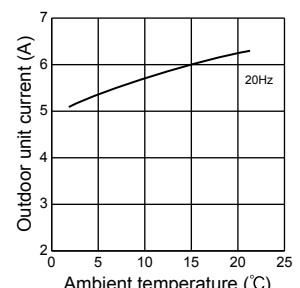

MXZ-3E54VA MXZ-3E68VA MXZ-4E72VA

MXZ-4E83VA MXZ-5E102VA MXZ-2E53VAHZ MXZ-4E83VAHZ

Relation between main sensor and actuator

Sensor	Purpose	Actuator					
		Compressor	LEV	Outdoor fan motor	4-way valve	2-way solenoid valve *1	Defrost heater *2
Discharge temperature thermistor	Protection	○	○			○	
Indoor coil temperature thermistor	Cooling: Coil frost prevention	○				○	
	Heating: High pressure protection	○	○				
Defrost thermistor	Heating: Defrosting	○	○	○	○		
Fin temperature thermistor	Protection	○		○			
Ambient temperature thermistor	Control/Protection	○	○	○		○	
	Heating: Defrosting (Heater)						○
Outdoor heat exchanger temperature thermistor	Cooling: Control/Protection	○	○	○		○	
Capacity code	Control	○	○				

*1 **MXZ-4E83VAHZ**

*2 **MXZ-2E53VAHZ, 4E83VAHZ**

**MXZ-3E54VA MXZ-3E68VA MXZ-4E72VA
MXZ-4E83VA MXZ-5E102VA MXZ-2E53VAHZ MXZ-4E83VAHZ**

10-1. PRE-HEAT CONTROL

If moisture gets into the refrigerant cycle, or when refrigerant is liquefied and collected in the compressor, it may interfere the startup of the compressor.

To improve startup condition, the compressor is energized even while it is not operating.

This is to generate heat at the winding.

The compressor uses about 50 W when pre-heat control is turned ON.

Pre-heat control is ON at initial setting.

[How to deactivate pre-heat control]

- ① Turn OFF the power supply for the air conditioner before making the setting.
- ② Set the "4" of SW2 on the outdoor control P.C. board to ON to deactivate pre-heat control function.

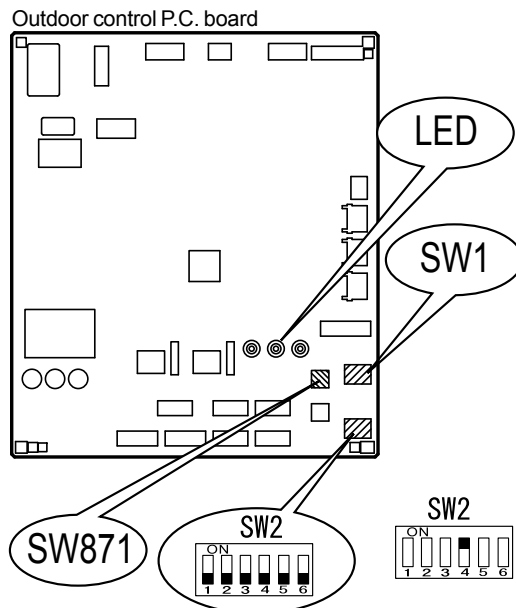

- ③ Turn ON the power supply for the air conditioner.

NOTE: Pre-heat control will be turned OFF when the breaker is turned OFF.

10-2. LOCKING THE OPERATION MODE OF THE AIR CONDITIONER (COOL, DRY, HEAT) (MXZ-4E83VAHZ)

With this function, you can lock the operation mode of the outdoor unit.

Once the operation mode is locked to either COOL/DRY mode or HEAT mode, the air conditioner operates in that mode only.

Default setting is required to activate this function.

Please explain about this function to your customers and ask them whether they want to use it.

[How to lock the operation mode]

- (1) Turn OFF the power supply and make sure that the LED goes off.
- (2) Set SW1 on the outdoor control P.C. board.
- (3) Turn ON the power supply.

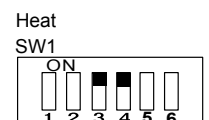
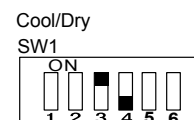

10-3. LOWERING THE OPERATING NOISE OF THE OUTDOOR UNIT (MXZ-4E83VAHZ)

With this function, you can lower the operating noise of the outdoor unit when the operation load is small, for example, during night time in COOL mode.

However, note that the cooling and heating capacity can also be lowered if this function is activated.

Default setting is required to activate this function.

Please explain about this function to your customers and ask them whether they want to use it.

[How to lower the operating noise]

- (1) Turn OFF the power supply and make sure that the LED goes off.
- (2) Set the "5" Switch of SW1 on the outdoor control P.C. board to ON to enable this function.
- (3) Turn ON the power supply.

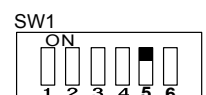

10-4. AUTO LINE CORRECTING

Outdoor unit has an auto line correcting function which automatically detects and corrects improper wiring or piping.

Improper wiring or piping can be automatically detected by pressing the piping/wiring correction switch (SW871). When improper wiring or piping is detected, wiring lines are corrected. This will be completed in about 10 to 20 minutes.

[How to activate this function]

1. Check that outside temperature is above 0°C.
(This function does not work when outside temperature is not above 0°C.)
2. Check that the stop valves of the liquid pipe and gas pipe are open.
3. Check that the wiring between indoor and outdoor unit is correct.
(If the wiring is not correct, this function does not work.)
4. Turn ON the power supply and wait at least 1 minute.
5. Press the piping/wiring correction switch (SW871) on the outdoor control P.C. board.
Do not touch energized parts.

LED indication during detection:

LED1 (Red)	LED2 (Yellow)	LED3 (Green)
Lighted	Lighted	Once

LED indication after detection:

LED1 (Red)	LED2 (Yellow)	LED3 (Green)	Indication
Lighted	Not lighted	Lighted	Completed (Problem corrected/ normal)
Once	Once	Once	Not completed (Detection failed)
Other indications			Refer to "SAFETY PRECAUTIONS WHEN LED FLASHES" located behind the service panel.

* Make sure that the valves are open and the pipes are not collapsed or clogged.

6. Press the switch to cancel.

LED indication after cancel :

LED1 (Red)	LED2 (Yellow)	LED3 (Green)
Lighted	Lighted	Not lighted

NOTE: Indoor unit cannot be operated while this function is activated.

When this function is activated while indoor unit is operating, the operation will be stopped.

Operate indoor unit after the auto line correcting is finished.

Pressing the switch during detection cancels this function.

The record of auto line correcting can be confirmed in the following way:

Press the switch for more than 5 seconds.

LED will show the record of auto correcting for about 30 seconds as shown in the table below:

Number of blinks			Wiring line
LED1 (Red)	LED2 (Yellow)	LED3 (Green)	
Once	Once	Lighted	Not corrected
3 times	3 times	Lighted	Corrected

NOTE: Activate this function to confirm the correct wiring after replacing the outdoor control P.C. board.

(Previous records are deleted when the outdoor control P.C. board is replaced.)

The record cannot be shown if auto line correcting is not canceled (Refer to "How to activate this function").

10-5. CHANGING THE AMPERE LIMIT (MXZ-2E53VAHZ MXZ-4E83VAHZ)

With this function, the amount of current that flows in the outdoor unit can be changed.

NOTE: Use this function only when the amount of current exceeds the allowed value.

[How to change the ampere limit]

- (1) Be sure to turn off the main power for the air conditioner before making the setting.
- (2) Make the setting referring to the table below.
- (3) Turn ON the power supply.

SW2 on the outdoor control P.C. board

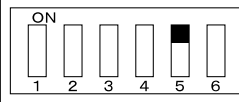
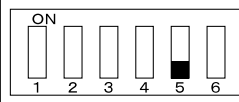
SW2	MXZ-2E53VAHZ	MXZ-4E83VAHZ
	Factory setting 13.6 A	21 A
	18.4 A	Factory setting 25 A

**MXZ-3E54VA MXZ-3E68VA MXZ-4E72VA
MXZ-4E83VA MXZ-5E102VA MXZ-2E53VAHZ MXZ-4E83VAHZ**

11-1. CAUTIONS ON TROUBLESHOOTING

1. Before troubleshooting, check the following:

- 1) Check the power supply voltage.
- 2) Check the indoor/outdoor connecting wire for miswiring.

2. Take care of the following during servicing

- 1) Before servicing the air conditioner, be sure to turn OFF the unit first with the remote controller, and after confirming the horizontal vane is closed, turn OFF the breaker and/or disconnect the power plug.
- 2) Be sure to turn OFF the power supply before removing the front panel, the cabinet, the top panel, and the P.C. board.
- 3) When removing the electrical parts, be careful of the residual voltage of smoothing capacitor.
- 4) When removing the P.C. board, hold the edge of the board with care NOT to apply stress on the components.
- 5) When connecting or disconnecting the connectors, hold the connector housing. DO NOT pull the lead wires.

<Incorrect>

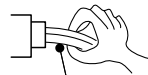

Lead wiring

<Correct>

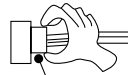

Connector housing

3. Troubleshooting procedure

- 1) Check if the OPERATION INDICATOR lamp on the indoor unit is flashing on and off to indicate an abnormality. To make sure, check how many times the OPERATION INDICATOR lamp is flashing on and off before starting service work.
- 2) Before servicing, check that the connector and terminal are connected properly.
- 3) When the P.C. board seems to be defective, check the copper foil pattern for disconnection and the components for bursting and discoloration.
- 4) Refer to 11-2, 11-3 and 11-4.

11-2. FAILURE MODE RECALL FUNCTION

This air conditioner can memorize the abnormal condition which has occurred once.

Even though LED indication listed on the troubleshooting check table (11-4.) disappears, the memorized failure details can be recalled.

1. Flow chart of failure mode recall function for the indoor/outdoor unit

Refer to the service manual of indoor unit.

2. Flow chart of the detailed outdoor unit failure mode recall function

Operational procedure

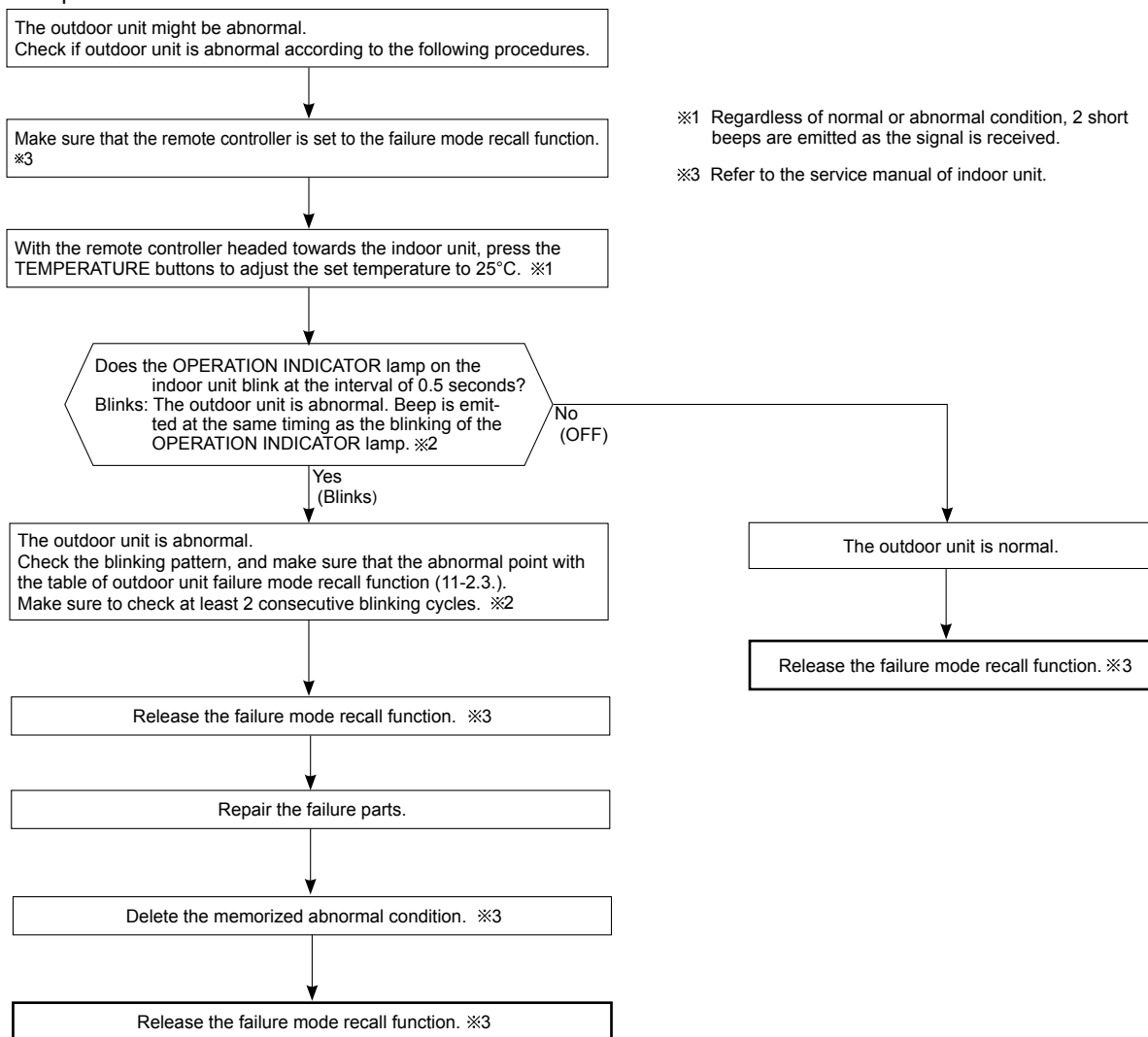

NOTE: 1. Make sure to release the failure mode recall function after it is set up, otherwise the unit cannot operate properly.
2. If the abnormal condition is not deleted from the memory, the last abnormal condition is kept memorized.

※2. Blinking pattern when outdoor unit is abnormal:

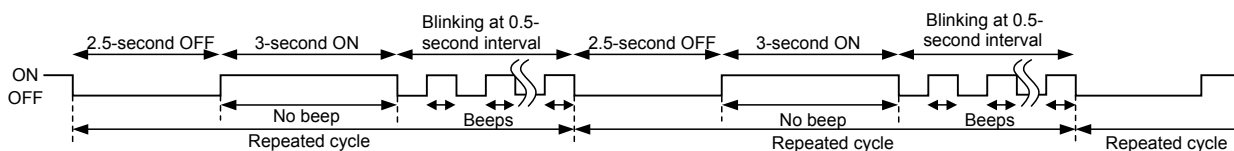

NOTE: Blinking patterns of this mode differ from the ones of Troubleshooting check table (11-4.).

3. Table of outdoor unit failure mode recall function

The left lamp of OPERATION INDICATOR lamp (Indoor unit)	Abnormal point (Failure mode/protection)	LED indication (Outdoor P.C. board)		Condition	Remedy	Indoor/outdoor unit failure mode recall function
		LED1	LED2			
OFF	None (Normal)	Lighted	Lighted			
2-time flash	Outdoor power system	Lighted	Lighted	Overcurrent protection cut-out operates 3 consecutive times within 1 minute after the compressor gets started, or converter protection cut-out or bus-bar voltage protection cut-out operates 3 consecutive times within 3 minutes after startup.	<ul style="list-style-type: none"> • Check the connection of the compressor connecting wire. • Refer to 11-6. ㉔ "How to check inverter/compressor". • Check the stop valve. 	○
3-time flash	Discharge temperature thermistor	Lighted	Once	A thermistor shorts or opens during compressor running.	<ul style="list-style-type: none"> • Refer to 11-6. ㉔ "Check of outdoor thermistors". 	○
	Defrost thermistor	Lighted	Once			
	Ambient temperature thermistor	Lighted	Twice			
	Fin temperature thermistor	Lighted	3 times			
	P.C. board temperature thermistor	Lighted	4 times			
Outdoor heat exchanger temperature thermistor	Lighted	9 times		<ul style="list-style-type: none"> • Replace the outdoor control P.C. board. • Refer to 11-6. ㉔ "Check of outdoor thermistors". 		
4-time flash	Overcurrent	Once	Not lighted	21 A current flows into power module.	<ul style="list-style-type: none"> • Reconnect compressor connector. • Refer to 11-6. ㉔ "How to check inverter/compressor". • Check the stop valve. 	—
5-time flash	Discharge temperature	Lighted	Lighted	The discharge temperature exceeds 115°C (MXZ-3E54/3E68/4E72VA)/ 106°C (MXZ-4E83/5E102VA, MXZ-2E52VAHZ)/ 116°C (MXZ-4E83VAHZ) during operation. Compressor can restart if discharge temperature thermistor reads 80°C (MXZ-3E54/3E68/4E72VA)/95°C (MXZ-4E83/5E102VA, MXZ-2E52VAHZ)/100°C (MXZ-4E83VAHZ) or less 3 minutes later.	<ul style="list-style-type: none"> • Check refrigerant circuit and refrigerant amount. • Refer to 11-6. ㉔ "Check of LEV". 	—
6-time flash	High pressure	Lighted	Lighted	The outdoor heat exchanger temperature exceeds 70°C during cooling or the indoor gas pipe temperature exceeds 70°C during heating.	<ul style="list-style-type: none"> • Check refrigerant circuit and refrigerant amount. • Check the stop valve. 	—
7-time flash	Fin temperature	3 times	Not lighted	The fin temperature exceeds 88°C (MXZ-3E54/3E68/4E72/4E83/5E102VA, MXZ-2E52VAHZ)/89°C (MXZ-4E83VAHZ) during operation.	<ul style="list-style-type: none"> • Check around outdoor unit. • Check outdoor unit air passage. • Refer to 11-6. ㉔ "Check of outdoor fan motor". 	—
	P.C. board temperature	4 times	Not lighted	The P.C. board temperature exceeds 67°C (MXZ-3E54/3E68/4E72/4E83/5E102VA, MXZ-2E52VAHZ)/87°C (MXZ-4E83VAHZ) during operation.		
8-time flash	Outdoor fan motor	Lighted	Lighted	A failure occurs 3 consecutive times within 30 seconds after the fan gets started.	<ul style="list-style-type: none"> • Refer to 11-6. ㉔ "Check of outdoor fan motor". 	—
9-time flash	Outdoor control system	Lighted	5 times	Nonvolatile memory data cannot be read properly.	<ul style="list-style-type: none"> • Replace the outdoor control P.C. board. 	○
10-time flash	Low discharge temperature protection	Lighted	Lighted	The frequency of the compressor is kept 80 Hz or more and the discharge temperature is kept under 39°C for more than 20 minutes.	<ul style="list-style-type: none"> • Check refrigerant circuit and refrigerant amount. • Refer to 11-6. ㉔ "Check of LEV". 	—
11-time flash	Communication error between P.C. boards	Lighted	6 times	Communication error occurs between the outdoor control P.C. board and outdoor power P.C. board for more than 10 seconds.	<ul style="list-style-type: none"> • Check the connecting wire between outdoor control P.C. board and outdoor power P.C. board. 	—
				The communication between boards protection cut-out operates 2 consecutive times.		○
	Current sensor	Lighted	7 times	A short or open circuit is detected in the current sensor during compressor operating.	—	—
				Current sensor protection cut-out operates 2 consecutive times.		○
	Zero cross detecting circuit	5 times	Not lighted	Zero cross signal cannot be detected while the compressor is operating.	<ul style="list-style-type: none"> • Check the connecting wire among outdoor control P.C. board and outdoor power P.C. board. 	—
				The protection cut-out of the zero cross detecting circuit operates 10 consecutive times.		○
Converter	5 times	Not lighted	A failure is detected in the operation of the converter during operation.	<ul style="list-style-type: none"> • Check the voltage of power supply. • Replace the outdoor power P.C. board. 	—	
Bus-bar voltage	5 times	Not lighted	The bus-bar voltage exceeds 400 V or falls to low level during compressor operating.	<ul style="list-style-type: none"> • Check the voltage of power supply. • Replace the outdoor control P.C. board. 	—	
15-time flash	LEV and drain pump	Lighted	Lighted	The indoor unit detects an abnormality in the LEV and drain pump.	<ul style="list-style-type: none"> • Refer to 11-6. ㉔ "Check of LEV". • Check the drain pump of the indoor unit. 	—

11-3. INSTRUCTION OF TROUBLESHOOTING

- Check the indoor unit with referring to the indoor unit service manual, and confirm that there is any problem in the indoor unit.
Then, check the outdoor unit with referring to this page.

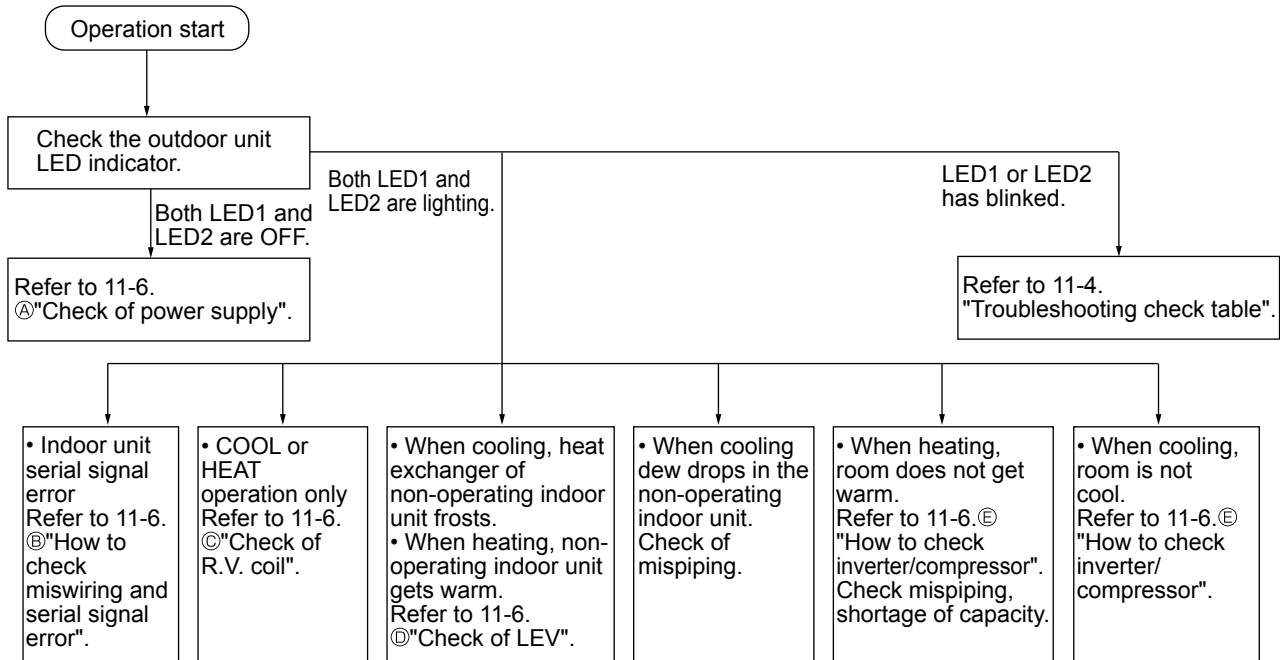

11-4. TROUBLESHOOTING CHECK TABLE

No.	Symptom	Indication		Abnormal point / Condition	Condition	Remedy
		LED1(Red)	LED2(Yellow)			
1	Outdoor unit does not operate.	Lighted	Once	LEV and drain pump	The indoor unit detects an abnormality in the LEV and drain pump.	<ul style="list-style-type: none"> Refer to 11-6. ④ "Check of LEV". Check the drain pump of the indoor unit.
2		Lighted	Twice	Outdoor power system	Overcurrent protection cut-out operates 3 consecutive times within 1 minute after the compressor gets started, or converter protection cut-out or bus-bar voltage protection cut-out operates 3 consecutive times within 3 minutes after startup.	<ul style="list-style-type: none"> Check the connection of the compressor connecting wire. Refer to 11-6. ⑤ "How to check inverter/compressor". Check the stop valve.
3		Lighted	3 times	Discharge temperature thermistor	A short circuit is detected in the thermistor during operation, or an open circuit is detected in the thermistor after 10 minutes of compressor startup.	<ul style="list-style-type: none"> Refer to 11-6. ⑥ "Check of outdoor thermistors".
4		Lighted	4 times	Fin temperature thermistor P. C. board temperature thermistor	A short or open circuit is detected in the thermistor during operation.	<ul style="list-style-type: none"> Refer to 11-6. ⑥ "Check of outdoor thermistors". Replace the outdoor control P.C. board.
5		Lighted	5 times	Ambient temperature thermistor Outdoor heat exchanger temperature thermistor Defrost thermistor	A short or open circuit is detected in the thermistor during operation. A short circuit is detected in the thermistor during operation, or an open circuit is detected in the thermistor after 5 minutes (in cooling) and 10 minutes (in heating) of compressor startup. A short circuit is detected in the thermistor during operation, or an open circuit is detected in the thermistor after 5 minutes of compressor startup.	<ul style="list-style-type: none"> Refer to 11-6. ⑥ "Check of outdoor thermistors".
6		Lighted	6 times	Zero cross detecting circuit (Outdoor control P.C. board)	Zero cross signal cannot be detected.	<ul style="list-style-type: none"> Replace the outdoor control P.C. board.
7		Lighted	7 times	Outdoor control system	The nonvolatile memory data cannot be read properly.	<ul style="list-style-type: none"> Replace the outdoor control P.C. board.
8		Lighted	8 times	Current sensor	Current sensor protection cut-out operates 2 consecutive times.	<ul style="list-style-type: none"> Replace the outdoor power P.C. board.
9		Lighted	11 times	Communication error between P.C. boards M-NET communication error	The communication protection cut-out between boards operates 2 consecutive times. M-NET adapter P.C. board detects an abnormality in the communication error.	<ul style="list-style-type: none"> Check the connecting wire between outdoor control P.C. board and outdoor power P.C. board. Check the connecting wire between M-NET adapter P.C. board and outdoor control P.C. board, or terminal block.
10		Lighted	12 times	Zero cross detecting circuit (Outdoor power P.C. board)	The protection cut-out of the zero cross detecting circuit operates 10 consecutive times.	<ul style="list-style-type: none"> Replace the outdoor power P.C. board.
11		Lighted	13 times	Current sensor	A short or open circuit is detected in the input current detection circuit during operation.	<ul style="list-style-type: none"> Replace the outdoor power P.C. board.
12		Lighted	14 times	Voltage sensor	A short or open circuit is detected in the input voltage detection circuit during operation.	<ul style="list-style-type: none"> Replace the outdoor power P.C. board.
13		Lighted	15 times	Relay operation	No relay operation is detected during operation.	<ul style="list-style-type: none"> Replace the outdoor power P.C. board.
14	'Outdoor unit stops and restarts 3 minutes later' is repeated.	Twice	Not lighted	IPM protection	Overcurrent is detected after 30 seconds of compressor startup.	<ul style="list-style-type: none"> Reconnect compressor connector. Refer to 11-6. ⑤ "How to check inverter/compressor".
15				Lock protection	Overcurrent is detected within 30 seconds of compressor startup.	<ul style="list-style-type: none"> Check the stop valve. Check the power module (PAM module).
16		3 times	Not lighted	Discharge temperature protection	The discharge temperature exceeds 115°C (MXZ-3E54/3E68/4E72VA)/ 106°C (MXZ-4E83/5E102VA, MXZ-2E52VAHZ)/ 116°C (MXZ-4E83VAHZ) during operation. Compressor can restart if discharge temperature thermistor reads 80°C (MXZ-3E54/3E68/4E72VA)/ 95°C (MXZ-4E83/5E102VA, MXZ-2E52VAHZ)/ 100°C (MXZ-4E83VAHZ) or less 3 minutes later.	<ul style="list-style-type: none"> Check the amount of gas and the refrigerant circuit. Refer to 11-6. ④ "Check of LEV".
17		4 times	Not lighted	Fin temperature protection P.C. board temperature protection	The fin temperature exceeds during operation. The P.C. board temperature exceeds during operation.	<ul style="list-style-type: none"> Check refrigerant circuit and refrigerant amount. Refer to 11-6. ④ "Check of outdoor fan motor".
18		5 times	Not lighted	High pressure protection	High pressure is detected with the high pressure switch (HPS) during operation. The outdoor heat exchanger temperature exceeds 70°C during cooling or the indoor gas pipe temperature exceeds 70°C during heating.	<ul style="list-style-type: none"> Check around of gas and the refrigerant circuit. Check the stop valve.
19		6 times	Not lighted	Pre-heating protection	Overcurrent is detected during pre-heating.	<ul style="list-style-type: none"> Reconnect compressor connector. Refer to 11-6. ⑤ "How to check inverter/compressor". Check the power module.
20		8 times	Not lighted	Converter protection	A failure is detected in the operation of the converter during operation.	<ul style="list-style-type: none"> Replace the outdoor power P.C. board.
21		9 times	Not lighted	Bus-bar voltage protection	The bus-bar voltage exceeds 400 V or falls to low level during compressor operating.	<ul style="list-style-type: none"> Check the voltage of power supply. Replace the outdoor power P.C. board or the outdoor control P.C. board. Refer to 11-6. ④ "Check of bus-bar voltage".
22		11 times	Not lighted	Low outside temperature protection (cooling)	The ambient became -12°C or less.	—



No.	Symptom	Indication		Abnormal point / Condition	Condition	Remedy	
		LED1(Red)	LED2(Yellow)				
22	'Outdoor unit stops and restarts 3 minutes later' is repeated.	13 times	Not lighted	Outdoor fan motor	A failure occurs 3 consecutive times within 30 seconds after the fan gets started.	• Refer to 11-6. Ⓢ "Check of outdoor fan motor".	
23		Lighted	8 times	Current sensor protection	A short or open circuit is detected in the current sensor during compressor operating.	• Replace the outdoor power P.C. board.	
24		Lighted	11 times	Communication between P.C. boards protection	Communication error occurs between the outdoor control P.C. board and outdoor power P.C. board for more than 10 seconds.	• Check the connecting wire between outdoor control P.C. board and outdoor power P.C. board.	
25		Lighted	12 times	Zero cross detecting circuit (Outdoor power P.C. board)	Zero cross signal cannot be detected while the compressor is operating.	• Replace the outdoor power P.C. board.	
26	Outdoor unit operates.	Once	Lighted	Primary current protection	The input current exceeds 13.6 A (MXZ-2E53VAHZ)/15 A (MXZ-3E54VA/3E68VA/4E72VA)/18.4 A (MXZ-4E83VA/5E102VA)/25 A (MXZ-4E83VAHZ).	These symptoms do not mean any abnormality of the product, but check the following points. • Check if indoor filters are clogged. • Check if refrigerant is short. • Check if indoor/outdoor unit air circulation is short cycled.	
27		Twice	Lighted	High pressure protection	The indoor gas pipe temperature exceeds 45°C during heating.		
				Defrosting in cooling	The indoor gas pipe temperature falls 3°C or below during cooling.		
28		3 times	Lighted	Discharge temperature protection	The frequency of the compressor is kept 80 Hz or more and the discharge temperature is kept under 50°C(COOL mode)/40°C(HEAT mode) for more than 40 minutes.		• Check refrigerant circuit and refrigerant amount. • Refer to 11-6. Ⓢ "Check of LEV". • Refer to 11-6. Ⓢ "Check of outdoor thermistors".
29		4 times	Lighted	Low discharge temperature protection	The frequency of the compressor is kept 80 Hz or more and the discharge temperature is kept under 39°C for more than 20 minutes.		• Refer to 11-6. Ⓢ "Check of LEV". • Check refrigerant circuit and refrigerant amount.
30		5 times	Lighted	Cooling high pressure protection	The outdoor heat exchanger temperature exceeds 58°C during operation.		This symptom does not mean any abnormality of the product, but check the following points. • Check if indoor filters are clogged. • Check if refrigerant is short. • Check if indoor/outdoor unit air circulation is short cycled.
31		7 times	Lighted	High → Low Pressure bypass valve Cooling evaporating temperature drop prevention control	During cooling operation, the temperature of indoor heat exchanger becomes 3°C or less within 1 hour after the compressor starts running, or it becomes less than 12°C - 16°C* later than that. * It depends on the difference between the set temperature and the room temperature.		This symptom does not mean any abnormality of the product, but check the following points. • Check the indoor filters are not clogged. • Check there is sufficient refrigerant. • Check the indoor/outdoor unit air circulation is not short cycled.
32	11 times	Lighted	M-NET communication error	M-NET adapter P.C. board detects an abnormality in the communication error.	• Check the connecting wire between M-NET adapter P.C. board and outdoor control P.C. board, or terminal block.		
33	Outdoor unit operates normally.	7 times	Lighted	High → Low pressure bypass valve High pressure protection control at startup of heating operation	MXZ-4E83VAHZ The room temperature is 24°C or more when 1 or 2 unit(s) start(s) the heating operation.	This symptom does not mean any abnormality of the product.	
				High → Low pressure bypass valve Compressor oil tempering control at startup of heating operation	MXZ-4E83VAHZ Both the following are true: • The outside temperature is -2°C or less when the heating operation is started. • [(Discharge temperature) - (Indoor heat exchanger temperature)] < 5°C		
34		8 times	Lighted	Cooling evaporating temperature protection	During cooling operation, the temperature of indoor heat exchanger becomes 7°C - 11°C* or less within 1 hour after the compressor starts running, or it becomes 9°C - 17°C* or less later than that. * It depends on the indoor unit type/model or the difference between the set temperature and the room temperature.		
35	9 times	Lighted	Inverter check mode	The unit is operated with emergency operation switch.	—		
36		Lighted	Lighted	Normal	—	—	

NOTE 1. The location of LED is illustrated at the right figure. Refer to 11-7.1.

2. LED is lighted during normal operation.

The flashing frequency shows the number of times the LED blinks after every 2.5-second OFF.
(Example) When the flashing frequency is "2".

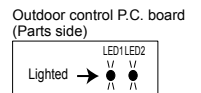
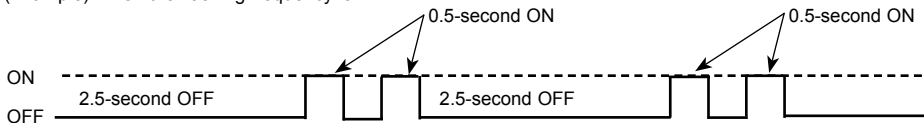

11-5. TROUBLE CRITERION OF MAIN PARTS

MXZ-3E54VA MXZ-3E68VA MXZ-4E72VA

MXZ-4E83VA MXZ-5E102VA MXZ-2E53VAHZ MXZ-4E83VAHZ

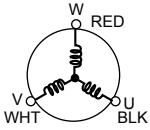
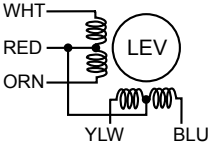
Part name	Check method and criterion												
Defrost thermistor (RT61) Fin temperature thermistor (RT64) Ambient temperature thermistor (RT65) Outdoor heat exchanger temperature thermistor (RT68)	Measure the resistance with a tester. Refer to 11-7. "Test point diagram and voltage", 1. "Outdoor control P.C.board", 2. "Outdoor power P.C. board", for the chart of thermistor.												
Discharge temperature thermistor (RT62)	Measure the resistance with a tester. Before measurement, hold the thermistor with your hands to warm it up. Refer to 11-7. "Test point diagram and voltage", 1. "Outdoor control P.C. board" for the chart of thermistor.												
Compressor 	Measure the resistance between terminals using a tester. (Winding temperature: -10 °C ~ 40 °C) <table border="1" style="width: 100%; text-align: center;"> <thead> <tr> <th colspan="4">Normal (Each phase)</th> </tr> <tr> <th>MXZ-3E54VA</th> <th>MXZ-3E68/4E72VA</th> <th>MXZ-4E83/5E102VA MXZ-2E53VAHZ</th> <th>MXZ-4E83VAHZ</th> </tr> </thead> <tbody> <tr> <td>0.86 Ω ~ 1.06 Ω</td> <td>0.63 Ω ~ 0.78 Ω</td> <td>0.83 Ω ~ 1.03 Ω</td> <td>0.77 Ω ~ 0.95 Ω</td> </tr> </tbody> </table>	Normal (Each phase)				MXZ-3E54VA	MXZ-3E68/4E72VA	MXZ-4E83/5E102VA MXZ-2E53VAHZ	MXZ-4E83VAHZ	0.86 Ω ~ 1.06 Ω	0.63 Ω ~ 0.78 Ω	0.83 Ω ~ 1.03 Ω	0.77 Ω ~ 0.95 Ω
Normal (Each phase)													
MXZ-3E54VA	MXZ-3E68/4E72VA	MXZ-4E83/5E102VA MXZ-2E53VAHZ	MXZ-4E83VAHZ										
0.86 Ω ~ 1.06 Ω	0.63 Ω ~ 0.78 Ω	0.83 Ω ~ 1.03 Ω	0.77 Ω ~ 0.95 Ω										
Outdoor fan motor	• Refer to 11-6. © .												
R.V. coil	Measure the resistance using a tester. (Part temperature: -10 °C ~ 40 °C) <table border="1" style="width: 100%; text-align: center;"> <thead> <tr> <th colspan="3">Normal (Each phase)</th> </tr> <tr> <th>MXZ-3E54/3E68/4E72VA</th> <th>MXZ-4E83/5E102VA MXZ-2E53VAHZ</th> <th>MXZ-4E83VAHZ</th> </tr> </thead> <tbody> <tr> <td>1.26 kΩ ~ 1.62 kΩ</td> <td>1.20 kΩ ~ 1.77 kΩ</td> <td>1.24 kΩ ~ 1.86 kΩ</td> </tr> </tbody> </table>	Normal (Each phase)			MXZ-3E54/3E68/4E72VA	MXZ-4E83/5E102VA MXZ-2E53VAHZ	MXZ-4E83VAHZ	1.26 kΩ ~ 1.62 kΩ	1.20 kΩ ~ 1.77 kΩ	1.24 kΩ ~ 1.86 kΩ			
Normal (Each phase)													
MXZ-3E54/3E68/4E72VA	MXZ-4E83/5E102VA MXZ-2E53VAHZ	MXZ-4E83VAHZ											
1.26 kΩ ~ 1.62 kΩ	1.20 kΩ ~ 1.77 kΩ	1.24 kΩ ~ 1.86 kΩ											
Linear expansion valve 	Measure the resistance using a tester. (Part temperature: -10 °C ~ 40 °C) <table border="1" style="width: 100%; text-align: center;"> <thead> <tr> <th>Color of lead wire</th> <th>Normal</th> </tr> </thead> <tbody> <tr> <td>WHT - RED</td> <td rowspan="4">37.4 Ω ~ 53.9 Ω</td> </tr> <tr> <td>RED - ORN</td> </tr> <tr> <td>YLW - RED</td> </tr> <tr> <td>RED - BLU</td> </tr> </tbody> </table>	Color of lead wire	Normal	WHT - RED	37.4 Ω ~ 53.9 Ω	RED - ORN	YLW - RED	RED - BLU					
Color of lead wire	Normal												
WHT - RED	37.4 Ω ~ 53.9 Ω												
RED - ORN													
YLW - RED													
RED - BLU													
High pressure switch (HPS)	<table border="1" style="width: 100%; text-align: center;"> <thead> <tr> <th colspan="2">Pressure</th> <th>Normal</th> </tr> </thead> <tbody> <tr> <td rowspan="2">HPS</td> <td>3.43 ± 0.15 MPa</td> <td>Close</td> </tr> <tr> <td>4.41 ± 0.1 MPa</td> <td>Open</td> </tr> </tbody> </table>	Pressure		Normal	HPS	3.43 ± 0.15 MPa	Close	4.41 ± 0.1 MPa	Open				
Pressure		Normal											
HPS	3.43 ± 0.15 MPa	Close											
	4.41 ± 0.1 MPa	Open											

11-6. TROUBLESHOOTING FLOW

Outdoor unit does not operate.

Ⓐ Check of power supply

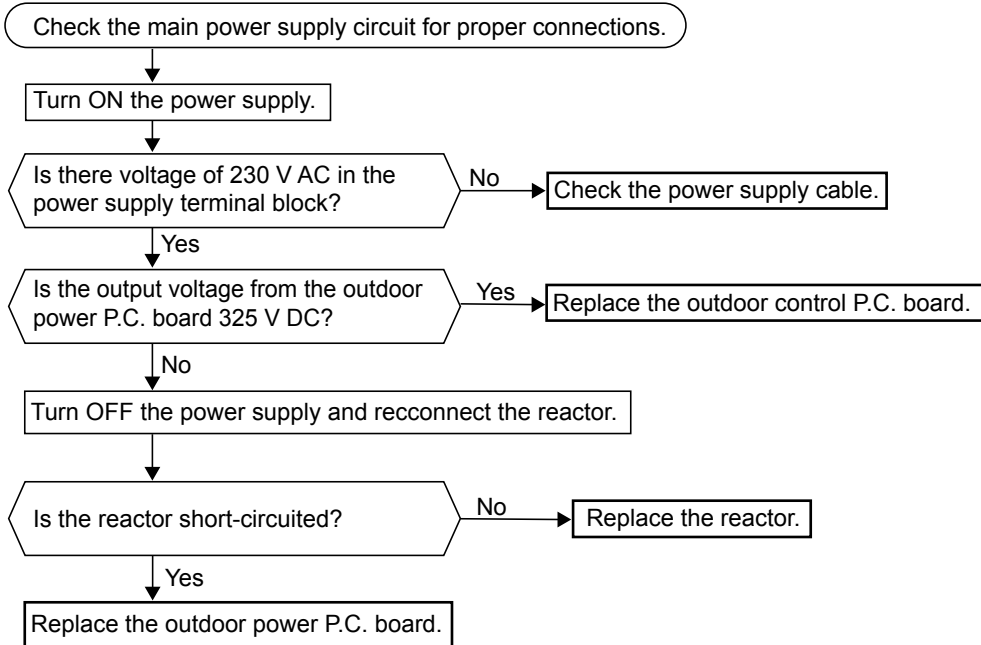

- When unit cannot operate neither by the remote controller nor by EMERGENCY OPERATION switch. Indoor unit does not operate.
- When OPERATION INDICATOR lamp flashes ON and OFF in every 0.5-second. Outdoor unit does not operate.

Ⓑ How to check miswiring and serial signal error (when outdoor unit does not work)

LED indication for communication status
Communication status is indicated by the LED.

Unit status
Blinking: normal communication
Lighting: abnormal communication or not connected

Pattern 1 and 2 is repeatedly displayed alternately. Each pattern is displayed for 10 seconds.

NOTE: "Lighting" in the table below does not indicate abnormal communication.

Outdoor control P.C. board

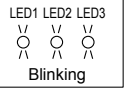

Pattern	LED 1	LED 2	LED 3
1	Unit A status	Unit B status	Lighted
2	Unit C status	Unit D status	Not lighted
3	Unit E status	—	Blinking

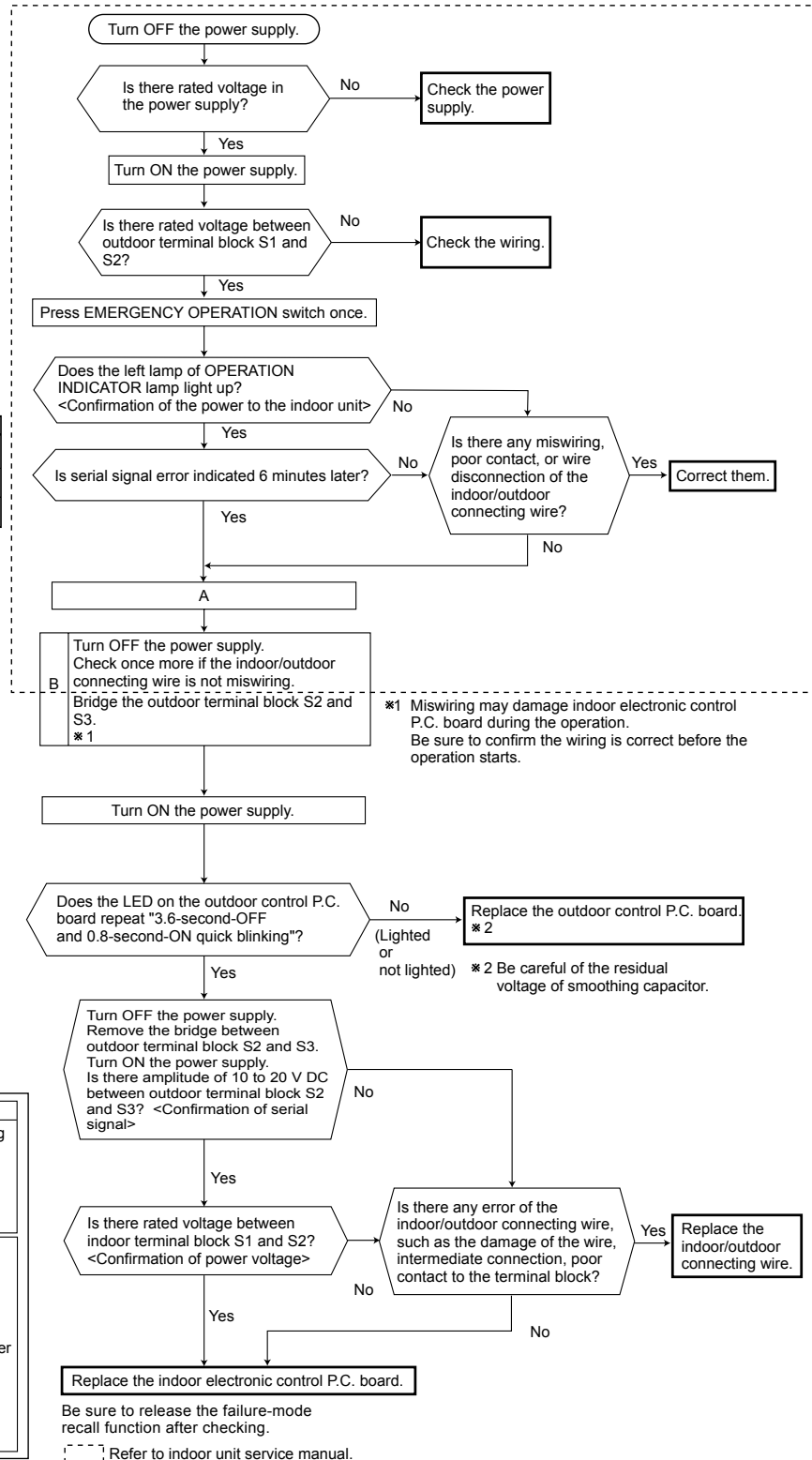



The cooling operation or heating operation does not operate.

© Check of R.V. coil

• When cooling operation does not work.

1. Disconnect the lead wire leading to the compressor.
2. 3 minutes after turning ON the power supply, start EMERGENCY OPERATION in COOL mode.

CNAC	Outdoor control P.C. board
CNAC2	Outdoor power P.C. board

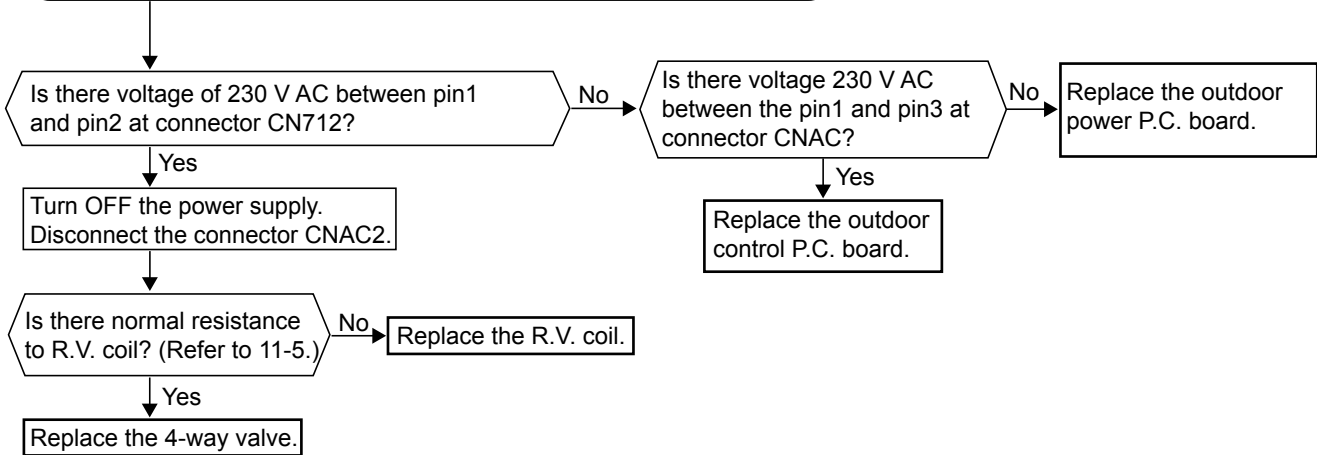

• When heating operation does not work.

1. Disconnect the lead wire leading to the compressor.
2. 3 minutes after turning ON the power supply, start EMERGENCY OPERATION in HEAT mode.

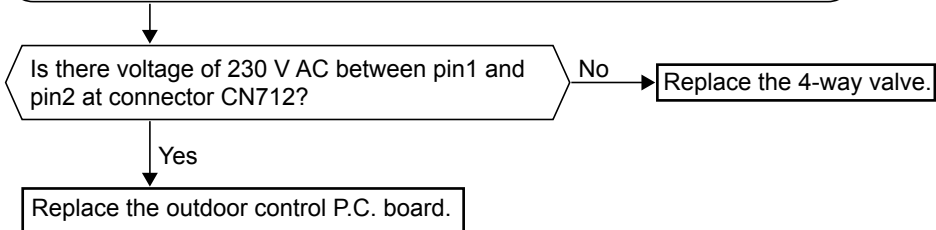

- When cooling, heat exchanger of non-operating indoor unit frosts.
- When heating, non-operating indoor unit gets warm.

① **Check of LEV**

Turn ON the power supply to the outdoor unit after checking LEV coil is mounted to the LEV body securely.

Is "click - click" sound heard?
Or, do you feel vibration of LEV coil with your hand?

Yes → Normal

No

Disconnect the connectors.
CN791: LEV A, CN792: LEV B,
CN793: LEV C (MXZ-3E/4E/5E),
CN794: LEV D (MXZ-4E/5E),
CN795: LEV E (MXZ-5E)
CN797: LEV R (MXZ-3E/4E72)
Is there normal resistance to LEV coil?
(Refer to 11-5.)

Yes → Replace the outdoor control P.C. board.

No

Replace LEV coil.

CN791	Outdoor control P.C. board
CN792	
CN793	
CN794	
CN795	

- When heating, room does not get warm.
- When cooling, room does not get cool.

Ⓔ How to check inverter/compressor

Disconnect the terminal of the compressor or the connector (CNMC) between the compressor and the outdoor power P.C. board. 3 minutes after the power supply is turned ON, start EMERGENCY OPERATION.

Measure the voltage between each lead wire leading to the compressor.
 U (BLK) - V (WHT)
 V (WHT) - W (RED)
 W (RED) - U (BLK)
 Output voltage: 50V-250V
 Is proper output voltage detected?
 ※1, ※2

- ※1 • After the outdoor fan starts running, wait for 1 minute or more before measuring the voltage.
- The output voltage values have the tolerance of $\pm 20\%$.
- ※2 • The output differs depending on the capacity or the number of indoor units to be operated.

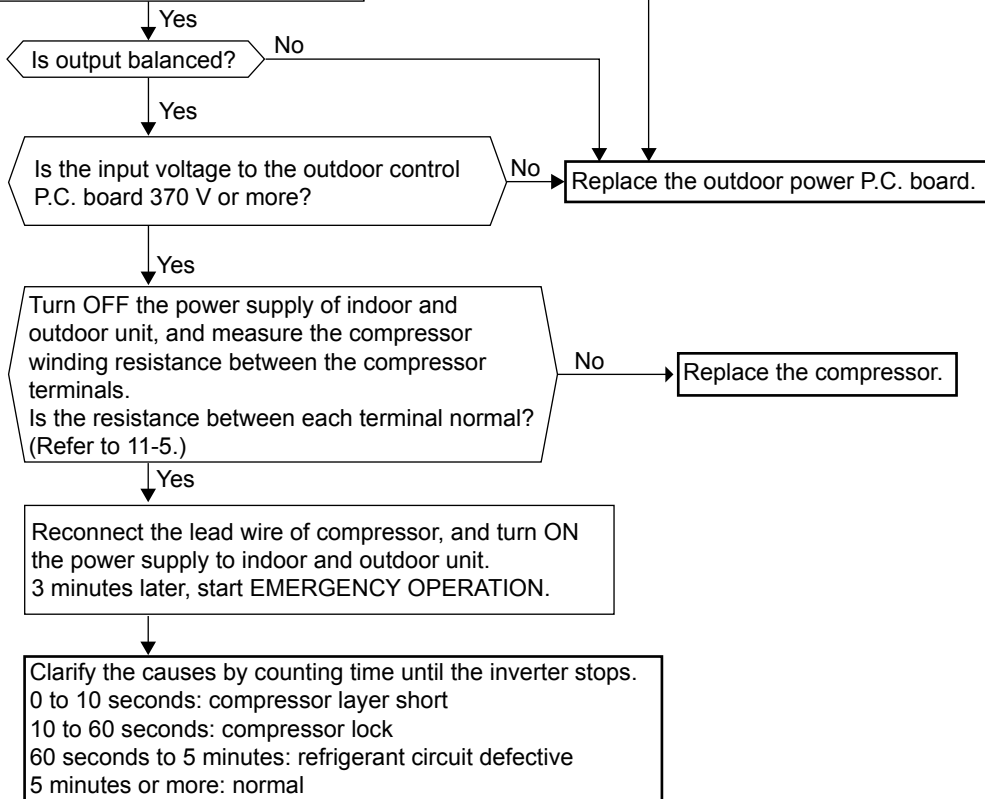

• When thermistor is abnormal.

Ⓕ Check of outdoor thermistors

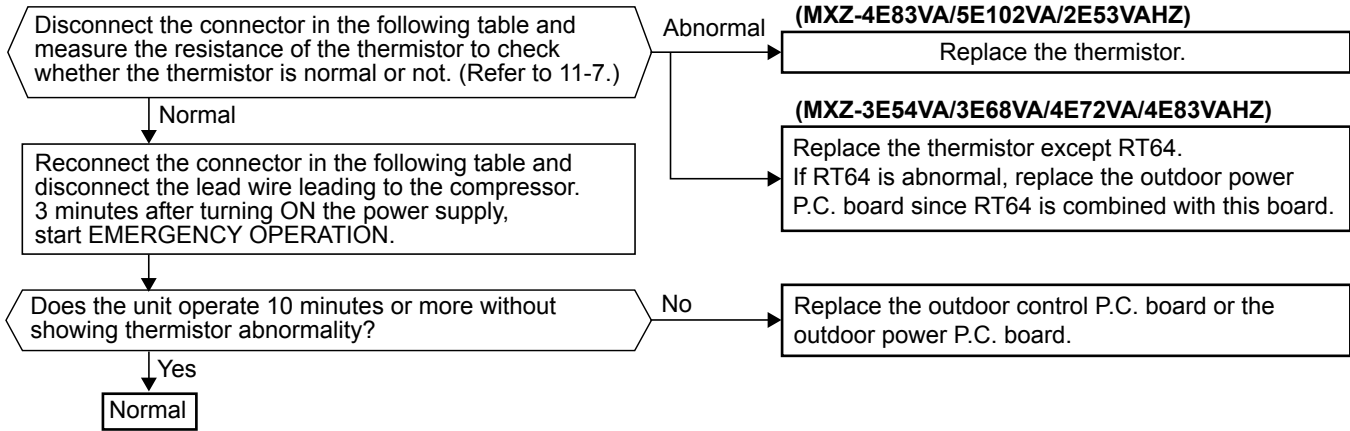

Thermistor	Symbol	Connector, Pin No.	Board
Defrost	RT61	Between CNTH1 pin1 and pin2	Outdoor control P.C. board
Discharge temperature	RT62	Between CNTH1 pin3 and pin4	
Outdoor heat exchanger temperature	RT68	Between CNTH1 pin7 and pin8	
Ambient temperature	RT65	Between CNTH2 pin1 and pin2	Outdoor power P.C. board
Fin temperature	RT64	Between CN171 pin1 and pin2	

• Fan motor does not operate or stops operating shortly after starting the operation.

⑥ Check of outdoor fan motor

Disconnect CNF1 and measure the resistance of the outdoor fan motor.

Is the resistance of outdoor fan motor normal? (Refer to right table.)

No → Replace the outdoor fan motor.

Yes

Does the outdoor fan motor rotate smoothly?

No → Replace the outdoor fan motor.

Yes

Turn on the power supply to start operation and measure the voltage of connector CNF1.

CNF1	Voltage
pin1 - pin4	325 V DC
pin5 - pin4	15 V DC
pin6 - pin4	1 - 5 V DC

CNF1	Outdoor control P.C. board
------	----------------------------

Measuring points	Resistance
pin1 - pin4	∞
pin5 - pin4	60 kΩ
pin6 - pin4	160 kΩ
pin7 - pin4	∞

* To measure the resistance, connect the negative (-) end of the tester to pin4.

* To measure the voltage, connect the negative (-) end of the tester to pin4.

* Voltage between pin4 and pin6 should be measured within 1 minute after the operation starts.

Is the voltage of connector CNF1 normal? (Refer to right table.)

No → Replace the outdoor control P.C. board.

Yes

Turn OFF the power supply and connect the connector CNF1. Turn ON the power supply and measure the voltage of connector CNF1 while rotating the motor by the hand.

Does the voltage between pin7 and pin4 of connector CNF1 repeat 0 V and 5 V?

No → Replace the outdoor fan motor.

Yes

Start operation.

Does the fan motor operate for about 5 seconds?

No → Replace the outdoor fan motor.

Yes

Replace the outdoor control P.C. board.

• When the operation frequency does not go up from the lowest frequency.

⊕ **Check of HPS**

CN63H	Outdoor control P.C. board
-------	----------------------------

1. Disconnect the connector CN63H in the outdoor control P.C. board.
2. Check the resistance of HPS after 1 minute has passed since the outdoor unit power supply was turned OFF.

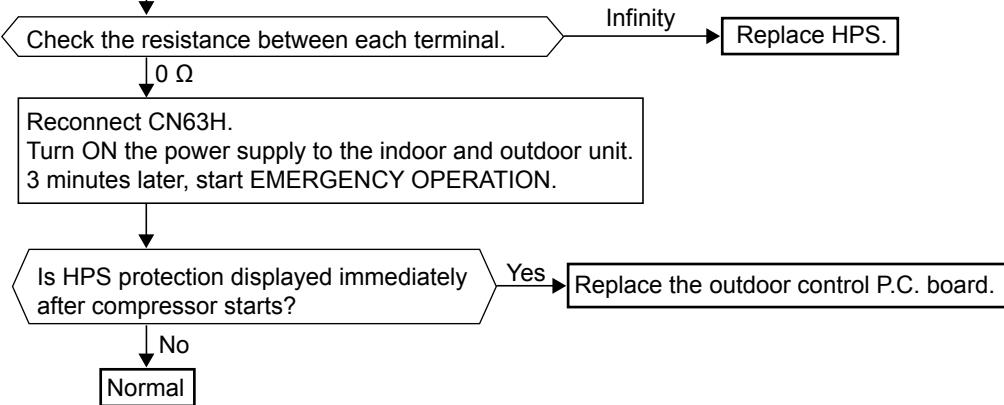

① **The other cases**

Indoor unit does not operate. (different operating models in multi system)

- When you try to run 2 indoor units simultaneously, one for cooling and the other for heating, the unit which transmits signal to the outdoor units first decides the operation mode.
- When the above situation occurs, set all the indoor units to the same mode, turn OFF the indoor units, and then turn them back ON.
- Though the top of the indoor unit sometimes gets warm, this does not mean malfunction. The reason is that the refrigerant gas continuously flows into the indoor unit even while it is not operating.

Ⓧ **Check of bus-bar voltage**

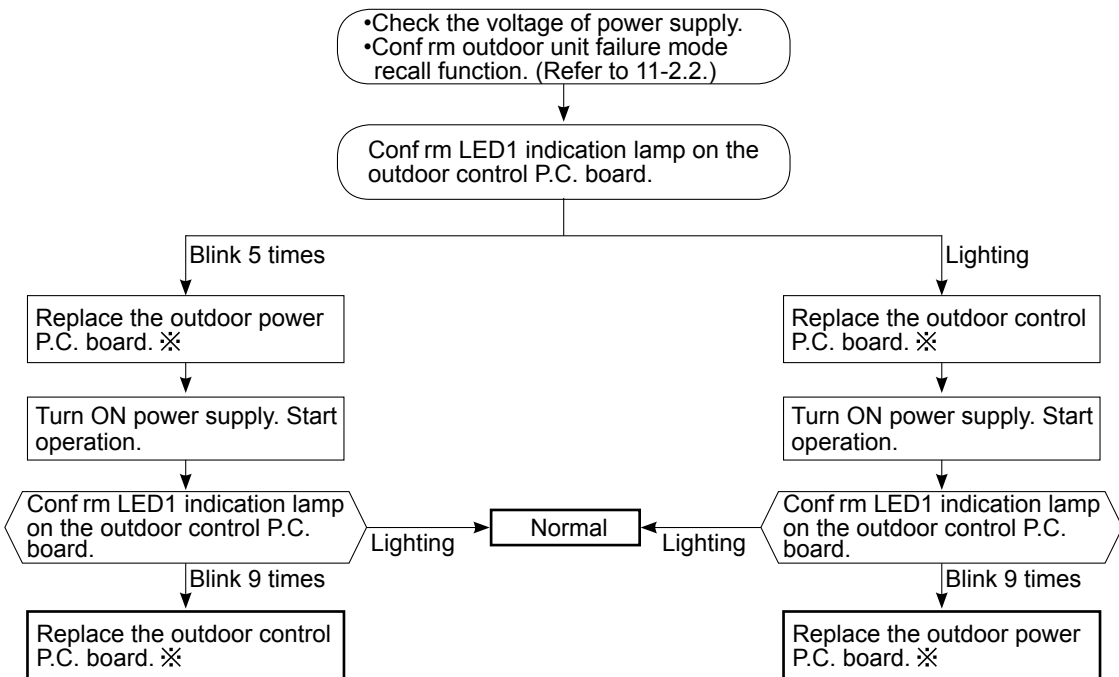

✖ Turn OFF power supply before removing P.C. board.

11-7. TEST POINT DIAGRAM AND VOLTAGE

1. Outdoor control P.C. board MXZ-3E54VA MXZ-3E68VA MXZ-4E72VA MXZ-4E83VAHZ - [E1], [ER1]

Defrost thermistor (RT61)
Ambient temperature thermistor (RT65)
Outdoor heat exchanger temperature thermistor (RT68)

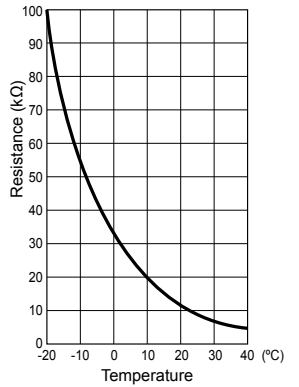
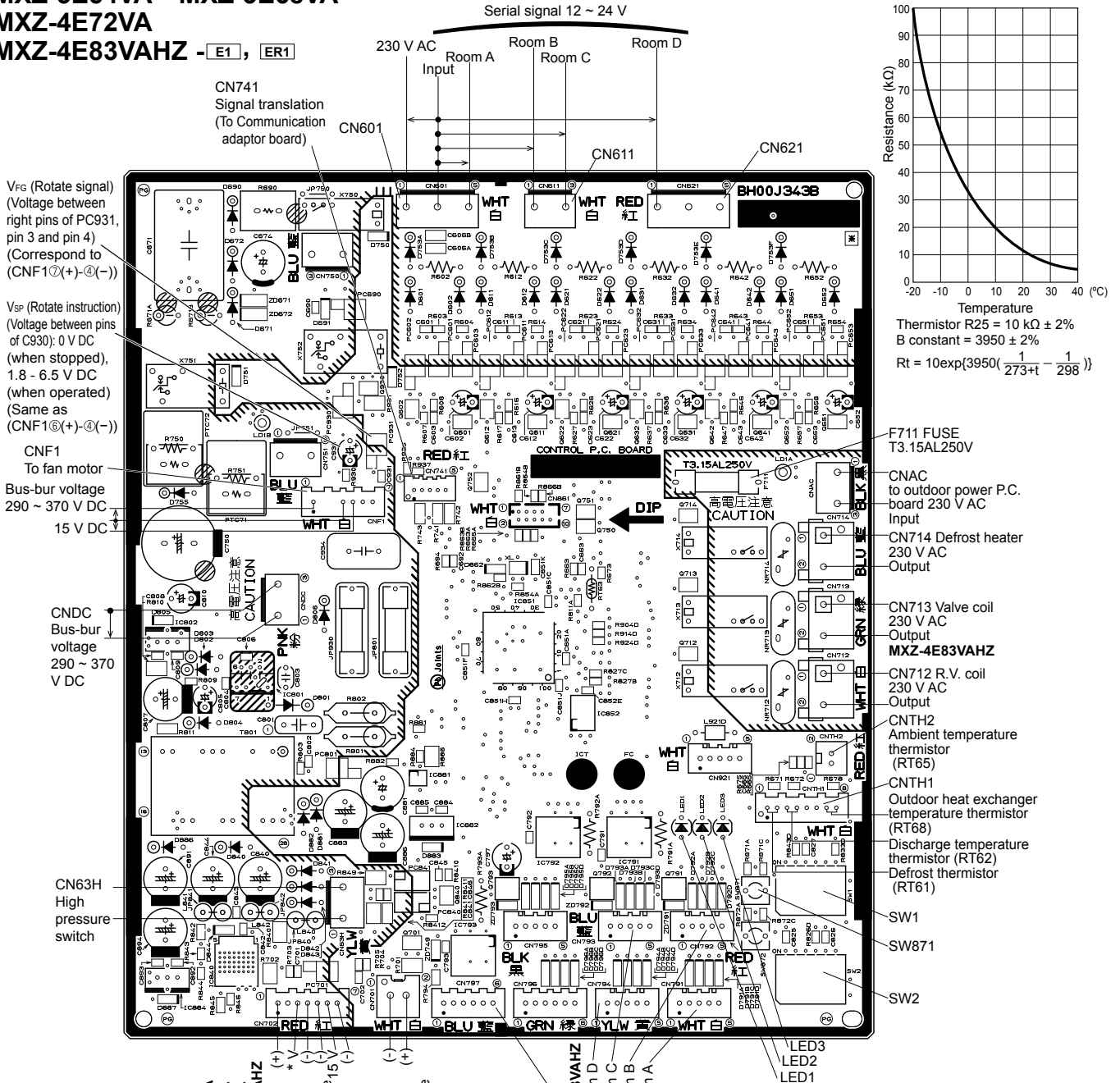

V_{FG} (Rotate signal)
(Voltage between right pins of PC931, pin 3 and pin 4)
(Correspond to (CNF1①(+)-④(-)))

V_{SP} (Rotate instruction)
(Voltage between pins of C930): 0 V DC (when stopped), 1.8 - 6.5 V DC (when operated)
(Same as (CNF1①(+)-④(-)))

CNF1
To fan motor
Bus-bur voltage 290 ~ 370 V DC
15 V DC

CNDC
Bus-bur voltage 290 ~ 370 V DC

CN63H
High pressure switch

* V
15 V: MXZ-3E54VA
MXZ-3E68VA
MXZ-4E72VA
18 V: MXZ-4E83VAHZ
CN702 Signal transmission (To power board)
5 V DC pulse wave¹⁵
CN701 Signal transmission (To power board)
5 V DC pulse wave

[CN797 LEV R except MXZ-4E83VAHZ
CN794 LEV Room D
CN793 LEV Room C
CN792 LEV Room B
CN791 LEV Room A
LEV: 12 V DC pulse wave

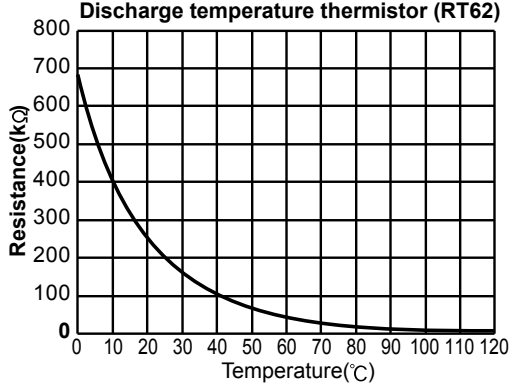

MXZ-4E83VAHZ - E2, ER2

Defrost thermistor (RT61)
Ambient temperature thermistor (RT65)
Outdoor heat exchanger temperature thermistor (RT68)

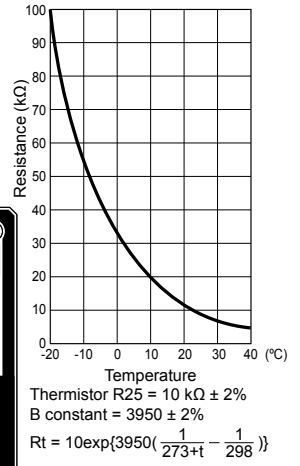
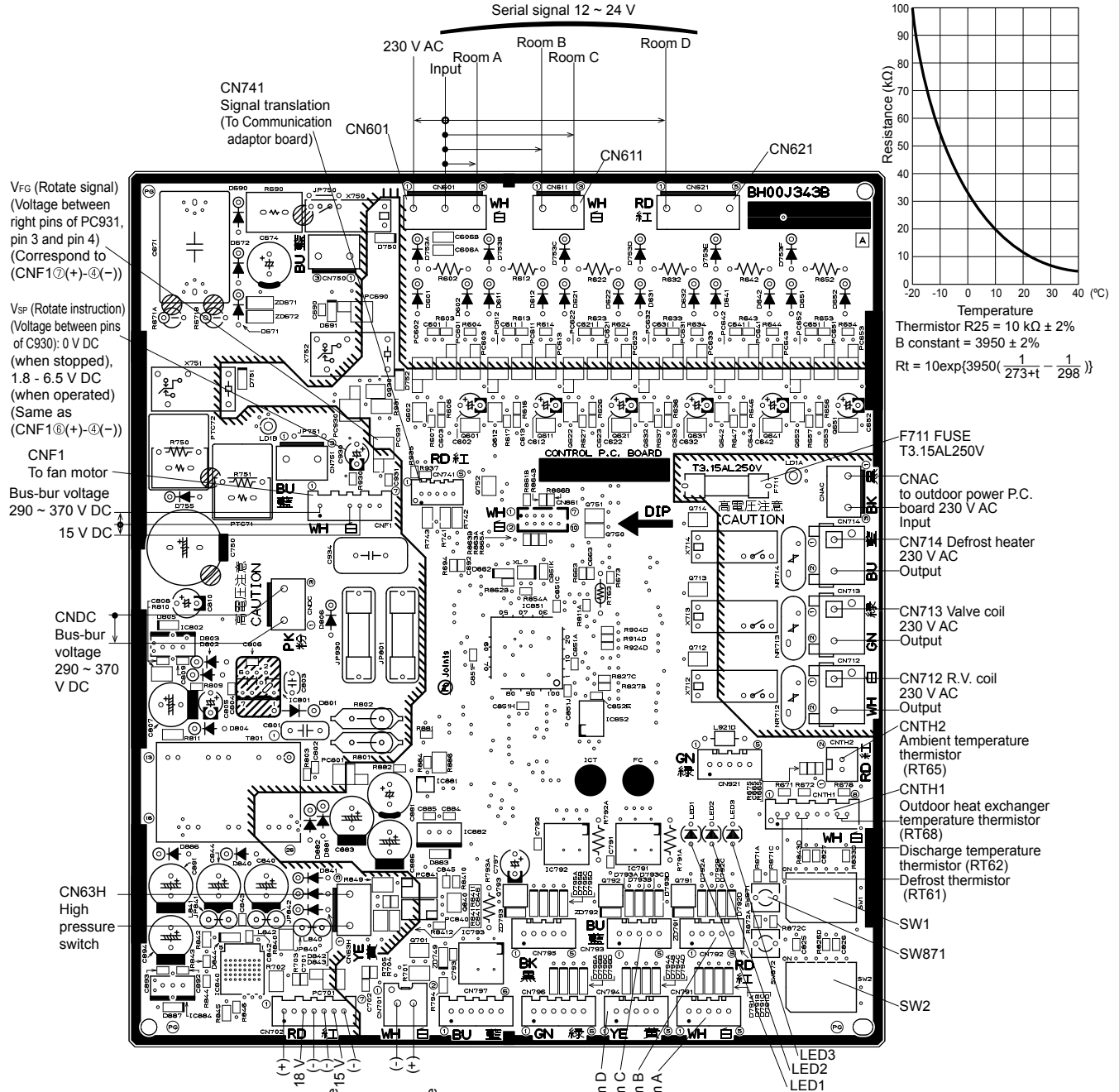

- F711 FUSE T3.15A/250V
- CNAC to outdoor power P.C. board 230 V AC Input
- CN714 Defrost heater 230 V AC Output
- CN713 Valve coil 230 V AC Output
- CN712 R.V. coil 230 V AC Output
- CNTH2 Ambient temperature thermistor (RT65)
- CNTH1 Outdoor heat exchanger temperature thermistor (RT68)
- Discharge temperature thermistor (RT62)
- Defrost thermistor (RT61)
- SW1
- SW871
- SW2

V_F (Rotate signal) (Voltage between right pins of PC931, pin 3 and pin 4) (Correspond to (CNF1⑦(+)-④(-)))

V_S (Rotate instruction) (Voltage between pins of C930): 0 V DC (when stopped), 1.8 - 6.5 V DC (when operated) (Same as (CNF1⑥(+)-④(-)))

CNF1 To fan motor Bus-bur voltage 290 ~ 370 V DC 15 V DC

CNDC Bus-bur voltage 290 ~ 370 V DC

CN63H High pressure switch

CN702 Signal transmission (To power board) 5 V DC pulse wave, 15

CN701 Signal transmission (To power board) 5 V DC pulse wave

CN794 LEV Room D
 CN793 LEV Room C
 CN792 LEV Room B
 CN791 LEV Room A
 LEV: 12 V DC pulse wave

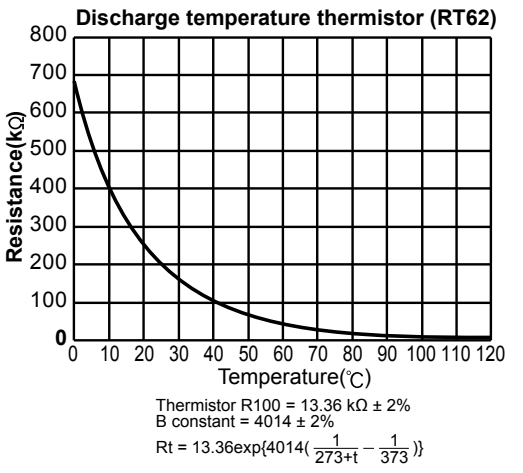

MXZ-4E83VA - [E1], [E2], [ET1], [ET2], [ER1]
 MXZ-5E102VA - [E1], [E2], [ET1], [ET2], [ER1]
 MXZ-2E53VAHZ

Defrost thermistor (RT61)
 Ambient temperature thermistor (RT65)
 Outdoor heat exchanger thermistor (RT68)

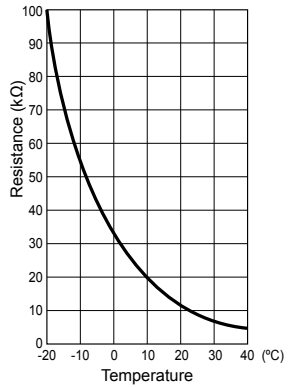
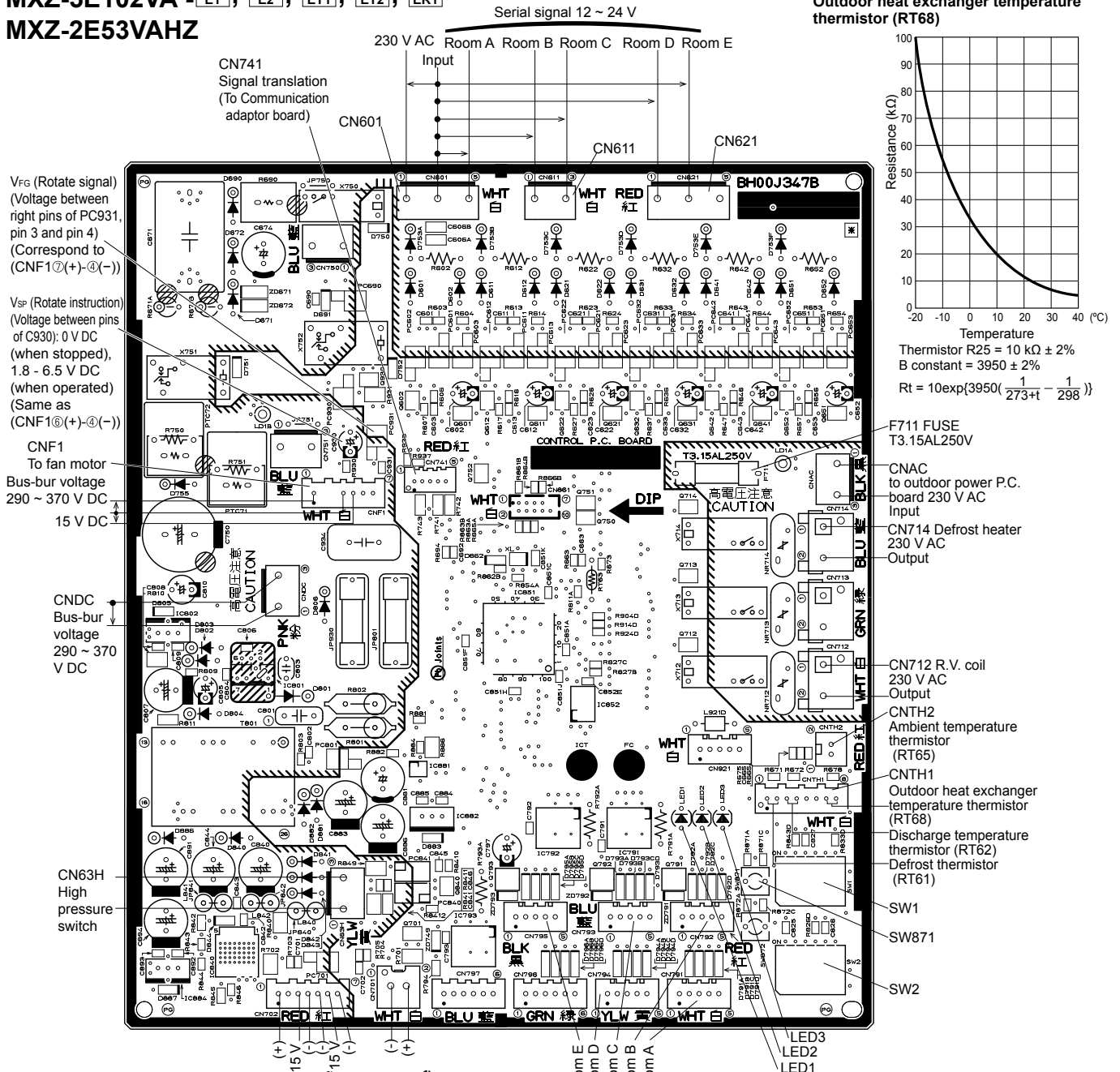

Thermistor R25 = 10 kΩ ± 2%
 B constant = 3950 ± 2%
 $R_t = 10 \exp\{3950(\frac{1}{273+t} - \frac{1}{298})\}$

V_{FG} (Rotate signal)
 (Voltage between right pins of PC931, pin 3 and pin 4)
 (Correspond to (CNF1⑥(+)-④(-)))

V_{SP} (Rotate instruction)
 (Voltage between pins of C930: 0 V DC (when stopped), 1.8 - 6.5 V DC (when operated))
 (Same as (CNF1⑥(+)-④(-)))

CNF1
 To fan motor
 Bus-bur voltage 290 ~ 370 V DC
 15 V DC

CNDC
 Bus-bur voltage 290 ~ 370 V DC

CN63H
 High pressure switch

F711 FUSE
 T3.15AL250V

CNAC
 to outdoor power P.C. board 230 V AC Input
 CN714 Defrost heater 230 V AC Output

CN712 R.V. coil 230 V AC Output

CNTH2 Ambient temperature thermistor (RT65)

CNTH1 Outdoor heat exchanger temperature thermistor (RT68)

Discharge temperature thermistor (RT62)
 Defrost thermistor (RT61)

SW1

SW871

SW2

CN702 Signal transmission (To power board) 5 V DC pulse wave, 15 V
 CN701 Signal transmission (To power board) 5 V DC pulse wave

CN795 LEV Room E
 CN794 LEV Room D
 CN793 LEV Room C
 CN792 LEV Room B
 CN791 LEV Room A
 LEV: 12 V DC pulse wave

LED3
 LED2
 LED1

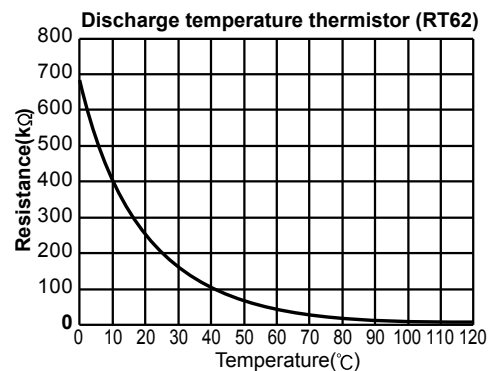

Thermistor R100 = 13.36 kΩ ± 2%
 B constant = 4014 ± 2%
 $R_t = 13.36 \exp\{4014(\frac{1}{273+t} - \frac{1}{373})\}$

MXZ-4E83VA - [E3], [ET3], [ER2]

MXZ-5E102VA - [E3], [ET3], [ER2]

Defrost thermistor (RT61)
Ambient temperature thermistor (RT65)
Outdoor heat exchanger temperature thermistor (RT68)

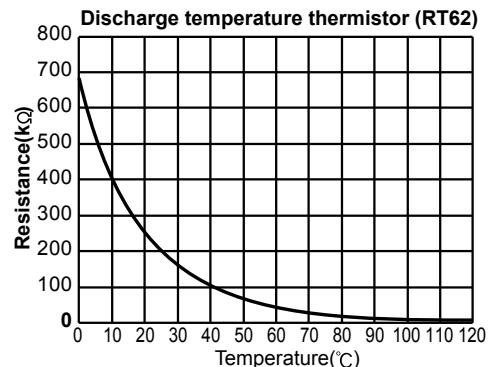
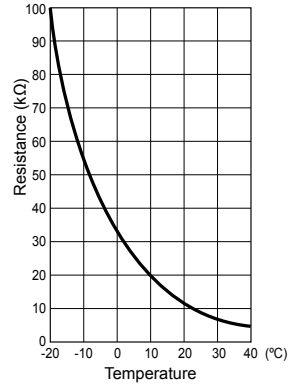
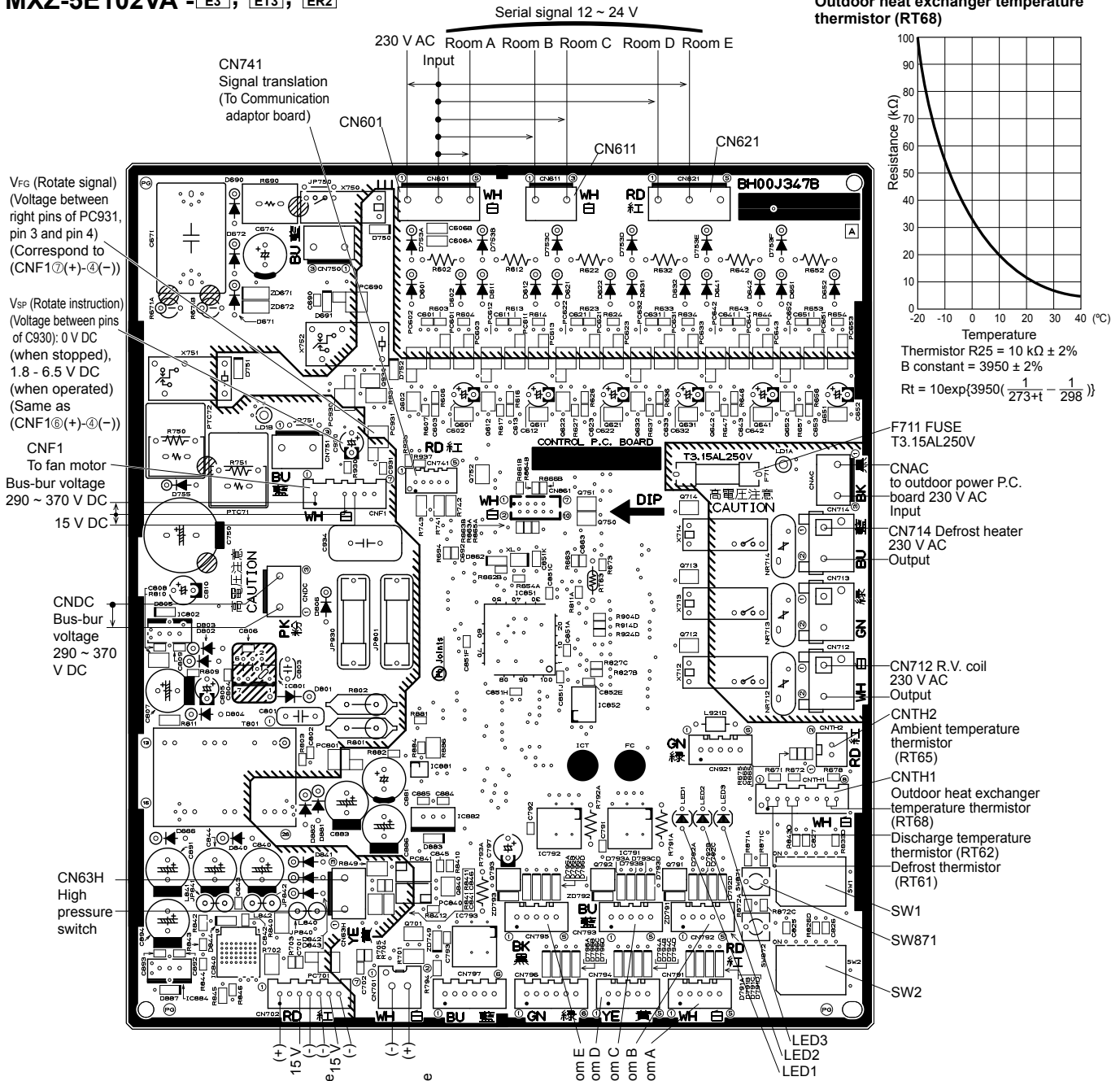

2. Outdoor power P.C. board

MXZ-3E54VA
MXZ-3E68VA
MXZ-4E72VA

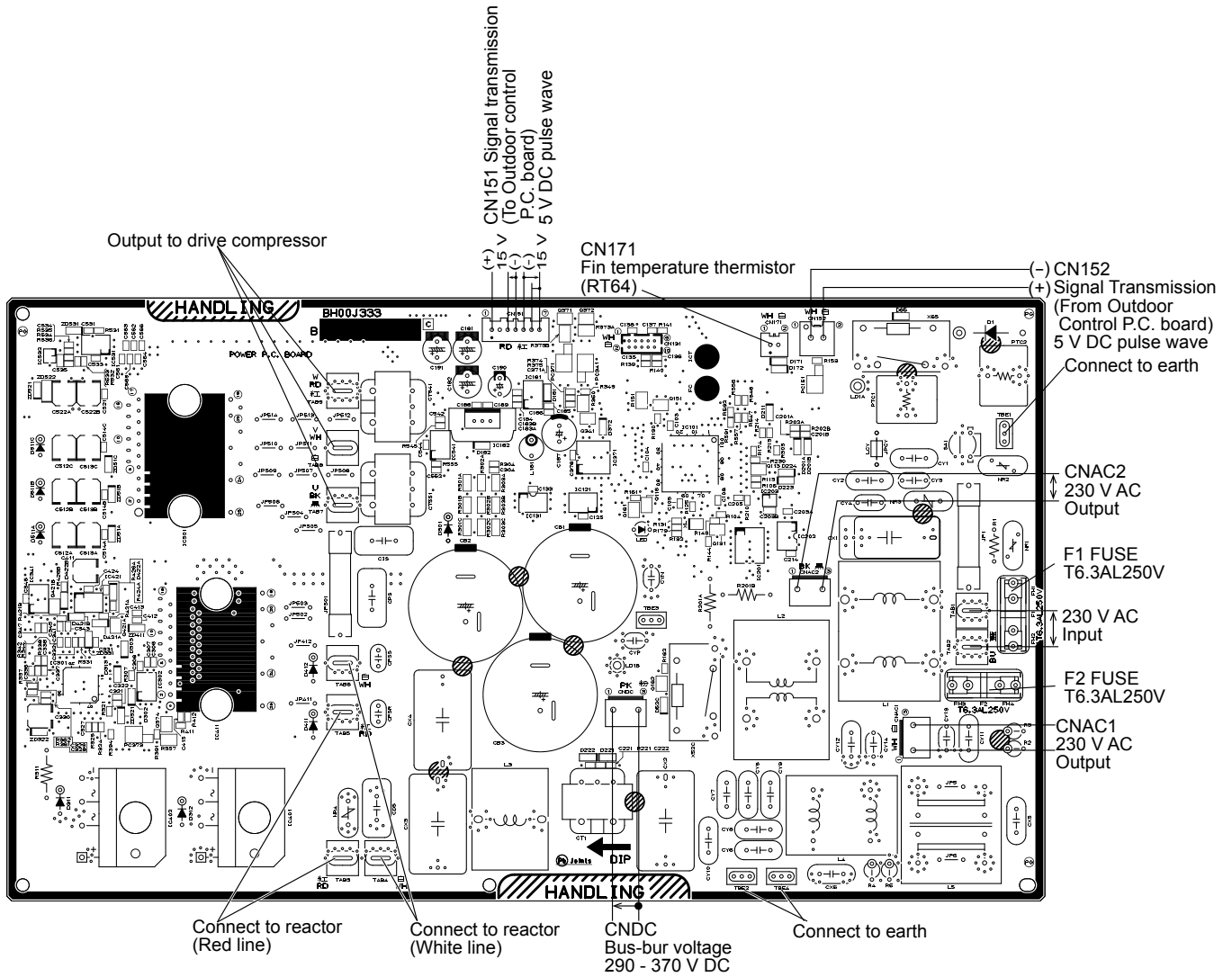

Fin temperature thermistor (RT64)

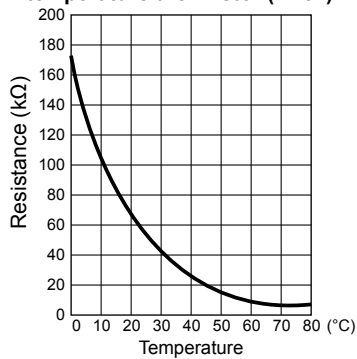

Thermistor R50 = 17 kΩ ± 2%
 B constant = 4150 ± 3%

$$R_t = 17 \exp\left\{4150 \left(\frac{1}{273+t} - \frac{1}{323} \right)\right\}$$

2. Outdoor power P.C. board

MXZ-4E83VA
MXZ-5E102VA
MXZ-2E53VAHZ

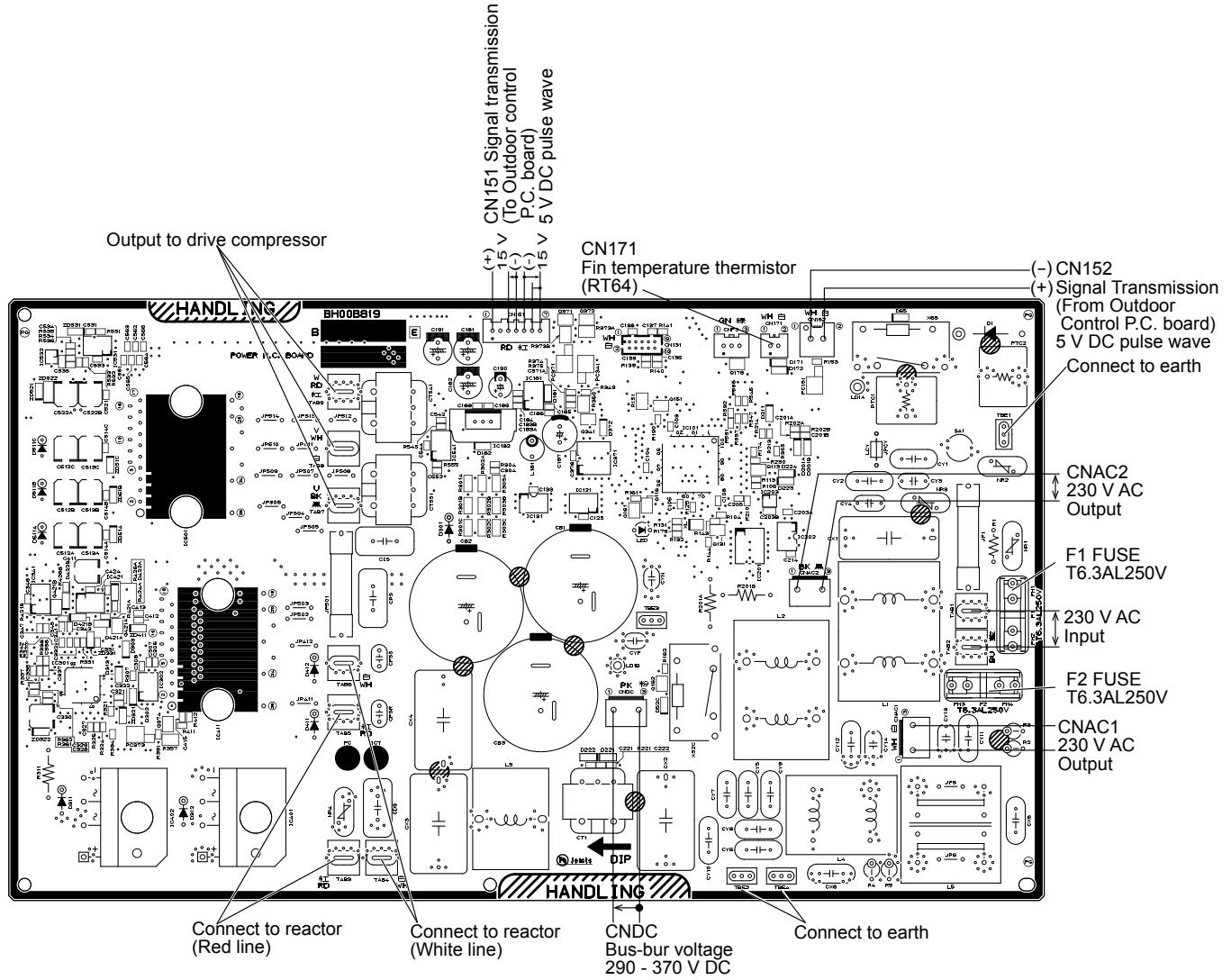

Fin temperature thermistor (RT64)

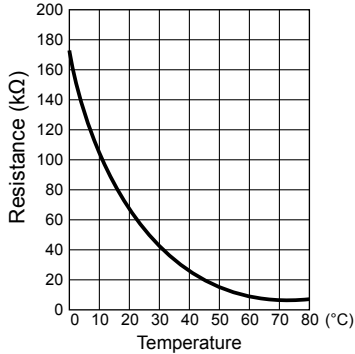

Thermistor $R_{50} = 17 \text{ k}\Omega \pm 2\%$

B constant = $4150 \pm 3\%$

$$R_t = 17 \exp\left\{4150 \left(\frac{1}{273+t} - \frac{1}{323}\right)\right\}$$

MXZ-4E83VAHZ

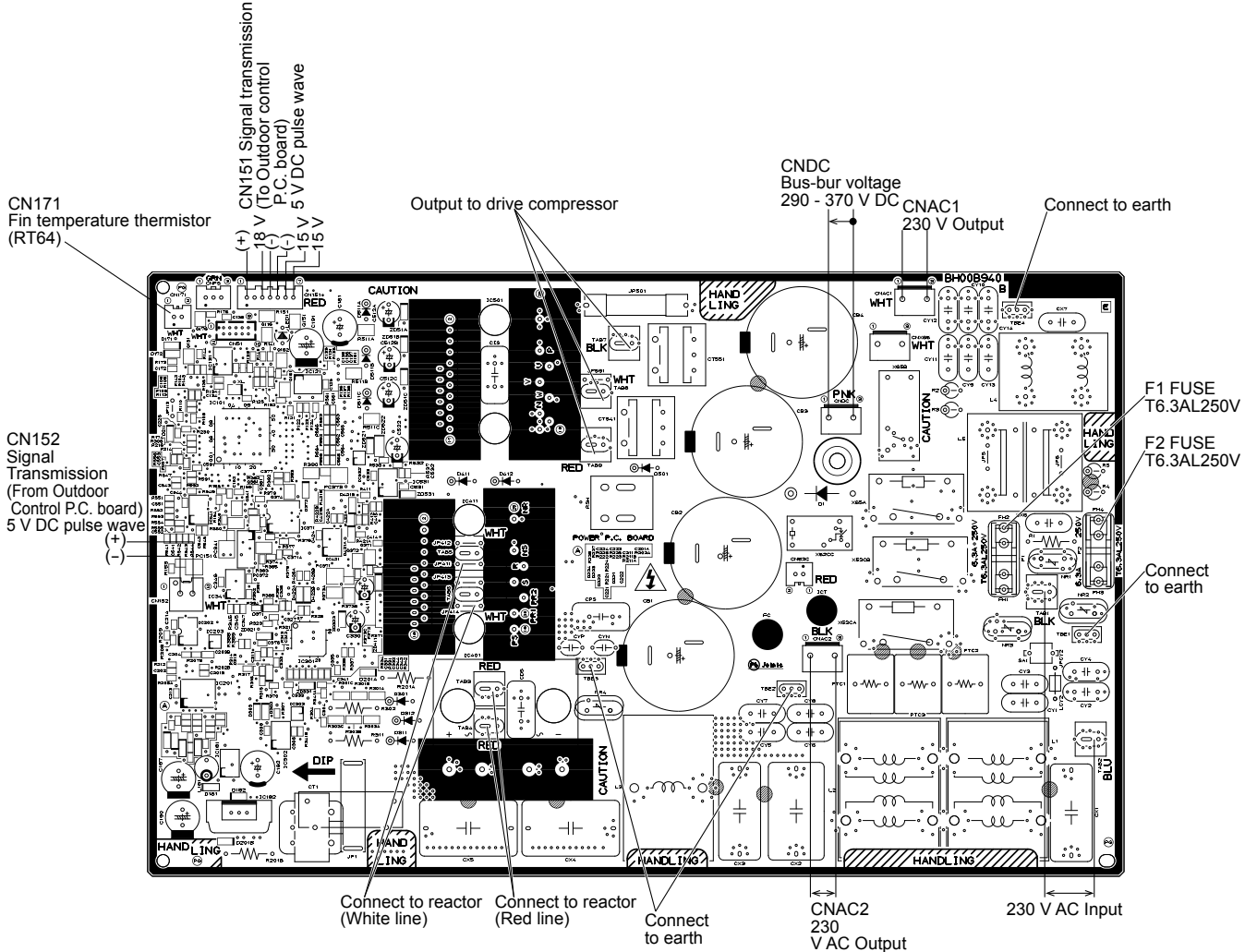

Fin temperature thermistor (RT64)

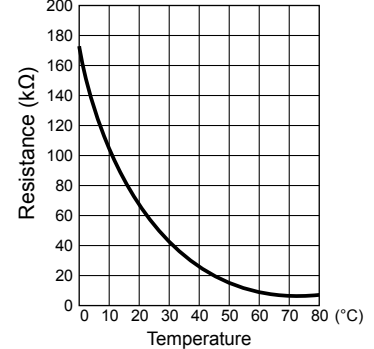

Thermistor R50 = 17 kΩ ± 2%
 B constant = 4150 ± 3%
 $R_t = 17 \exp\left\{4150 \left(\frac{1}{273+t} - \frac{1}{323}\right)\right\}$

<"Terminal with locking mechanism" Detaching points>

The terminal which has the locking mechanism can be detached as shown below.
There are 2 types (Refer to (1) and (2)) of the terminal with locking mechanism.
The terminal without locking mechanism can be detached by pulling it out.
Check the shape of the terminal before detaching.

(1) Slide the sleeve and check if there is a locking lever or not.

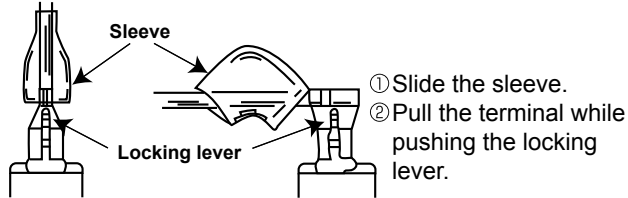

(2) The terminal with this connector has the locking mechanism.

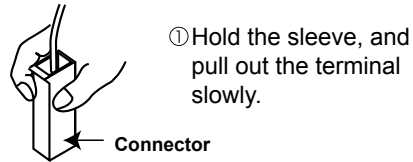

12-1. MXZ-3E54VA MXZ-3E68VA MXZ-4E72VA

NOTE: Turn OFF the power supply before disassembly.

OPERATING PROCEDURE	PHOTOS
<p>1. Removing the cabinet and the panels</p> <ol style="list-style-type: none"> (1) Remove the screws of the service panel, and remove the service panel. (2) Disconnect the power supply and indoor/outdoor connecting wire. (3) Remove the screws of the top panel, and remove the top panel. (4) Remove the screws of the cabinet, and remove the cabinet. (5) Remove the screws of the back panel, and remove the back panel (Photo 3). <p>Photo 3</p>	<p>Photo 1</p> <p>Photo 2</p>

OPERATING PROCEDURE

2. Removing the outdoor control P.C. board, the outdoor power P.C. board and the reactor

- (1) Remove the service panel (Photo 1).
- (2) Disconnect the power supply and indoor/outdoor connecting wire.
- (3) Remove the top panel, the cabinet, and the back panel (Photo 1, 2, 3).
- (4) Disconnect all connectors and lead wires on the outdoor control P.C. board.
- (5) Unhook the catches of the outdoor control P.C. board, and remove the outdoor control P.C. board.
- (6) Remove the screws of the electrical box assembly, unhook the catches of the electrical box assembly, and remove the electrical box assembly.
- (7) Remove the screws of outdoor control P.C. board holder, and remove the outdoor control P.C. board holder.
- (8) Remove the screws of the reactor, and remove the reactor.
- (9) Remove the screws of the reactor bed, and remove the reactor bed.
- (10) Remove the screws of the heat sink support, and remove the heat sink support.
- (11) Remove the screws fixing the outdoor power P.C. board.
- (12) Disconnect all connectors and lead wires on the outdoor power P.C. board.

Photo 7

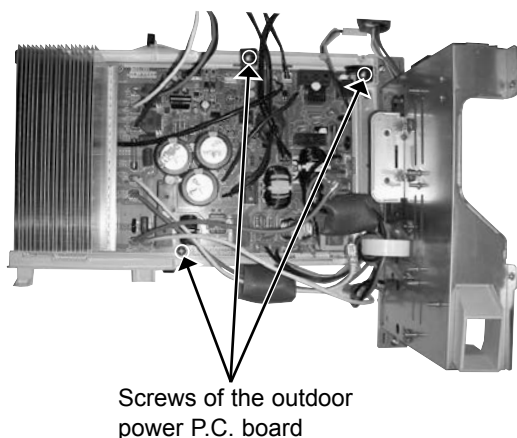

PHOTOS

Photo 4

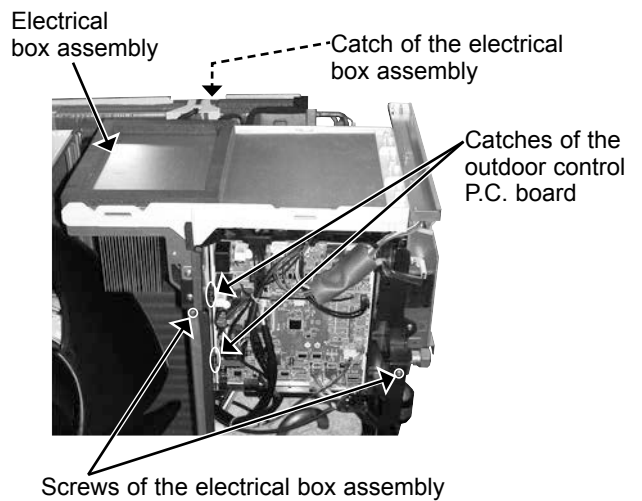

Photo 5

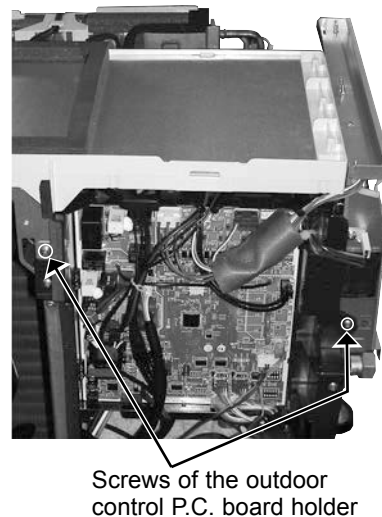
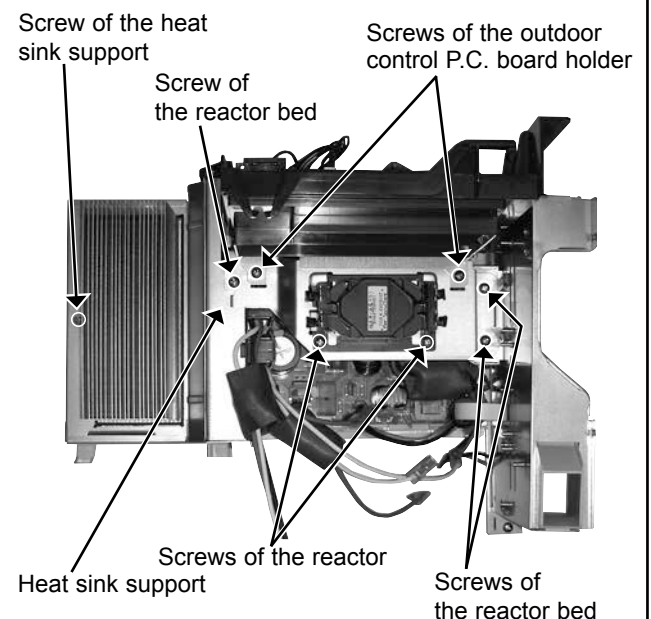

Photo 6



OPERATING PROCEDURE

3. Removing the fan motor

- (1) Remove the service panel (Photo 1).
- (2) Disconnect the power supply and indoor/outdoor connecting wire.
- (3) Remove the top panel, the cabinet, and the back panel (Photo 1, 2, 3).
- (4) Disconnect connectors CN712, CNF1, CNTH1, CNTH2, CN63H, CN791, CN792, CN793, CN794 (**MXZ-4E72VA**), CN797 on the outdoor control P.C. board and disconnect the relay connector of the compressor lead wire.
- (5) Remove the screws of the electrical box assembly, and remove the electrical box assembly (Photo 4).
- (6) Remove the propeller fan.
- (7) Remove the fan motor.

4. Removing the compressor and the 4-way valve

- (1) Remove the service panel (Photo 1).
- (2) Disconnect the power supply and indoor/outdoor connecting wire.
- (3) Remove the top panel, the cabinet, and the back panel (Photo 1, 2, 3).
- (4) Recover gas from the refrigerant circuit.

NOTE: Recover gas from the pipes until the pressure gauge shows 0 kg/cm² (0 MPa).
- (5) Disconnect the outdoor control P.C. board connectors: CNF1, CNTH1, CNTH2, CN63H, CN791, CN792, CN793, CN794 (**MXZ-4E72VA**), CN797, CN712.
- (6) Disconnect the compressor lead wire from the terminal of the compressor (U, V, W).
- (7) Remove the screws of the electrical box assembly, and remove the electrical box assembly (Photo 4).
- (8) Remove the propeller fan.
- (9) Remove the sound proof felt *1, *2 and *3 (**MXZ-3E54VA**).
- (10) Remove the screws of the separator, and remove the separator.
- (11) Detach the brazed parts of the compressor suction and discharge pipes.
- (12) Remove the compressor nuts and remove the compressor.
- (13) Detach the brazed parts of the 4-way valve and pipe.

PHOTOS

Photo 8

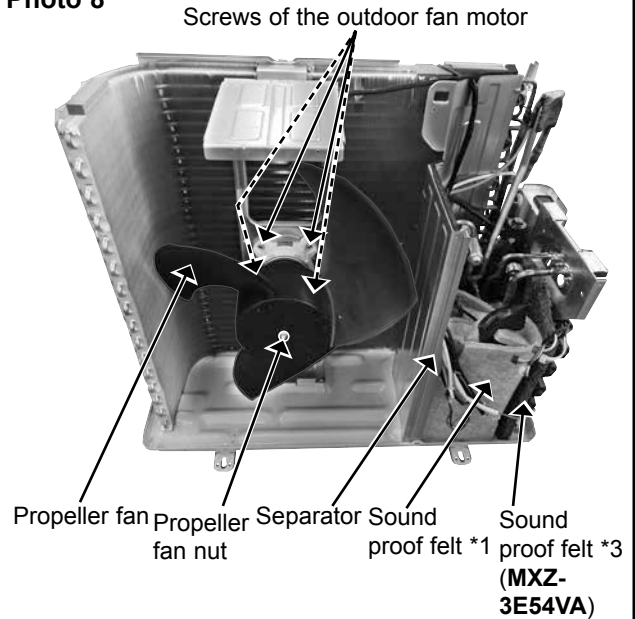

Photo 9

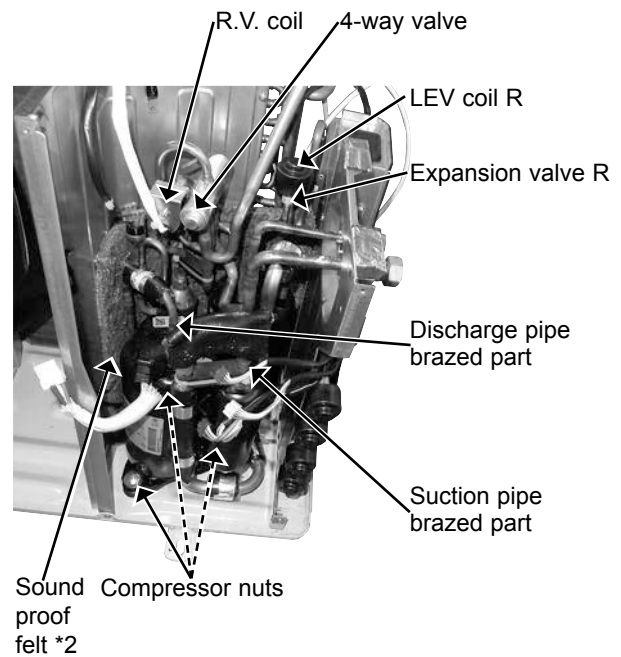
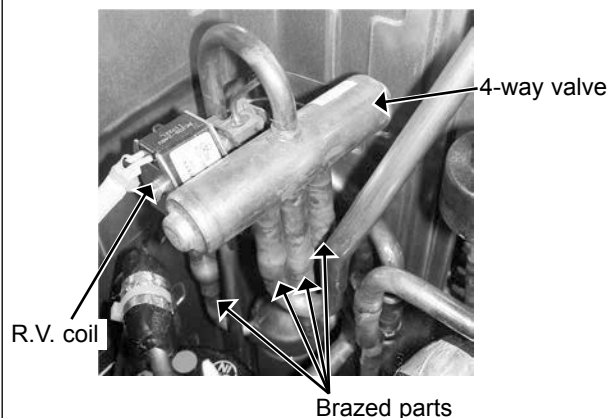
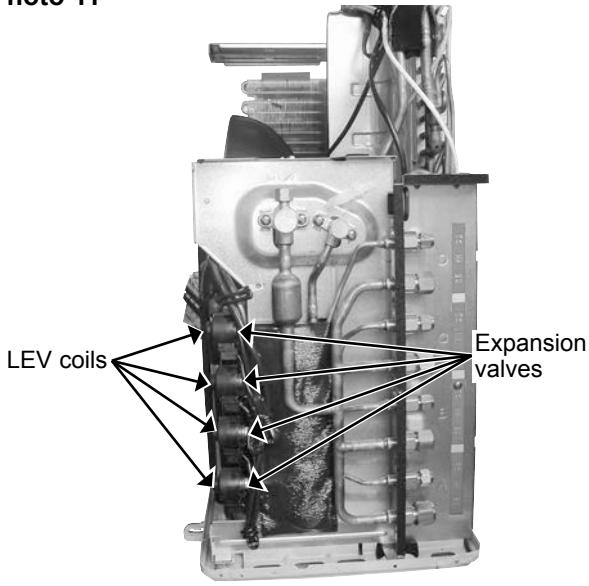

Photo 10





OPERATING PROCEDURE	PHOTOS
<p>5. Removing the expansion valve</p> <ul style="list-style-type: none">(1) Remove the service panel (Photo 1).(2) Remove the top panel, the cabinet, and the back panel (Photo 1, 2, 3). (Gas recovery is not required if the unit is pumped down.)(3) Remove the electrical parts for removing LEV R (Photo 4, 8).(4) Remove the LEV coils.(5) Detach the brazed parts of expansion valves and pipes.	<p>Photo 11</p>  <p>LEV coils</p> <p>Expansion valves</p>

12-2. MXZ-4E83VA MXZ-5E102VA

NOTE: Turn OFF the power supply before disassembly.

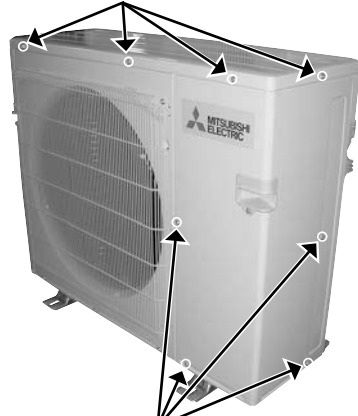
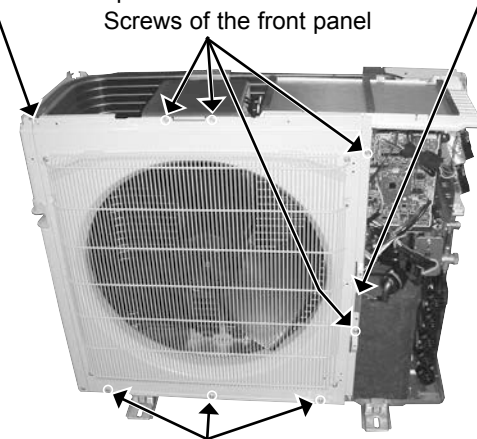
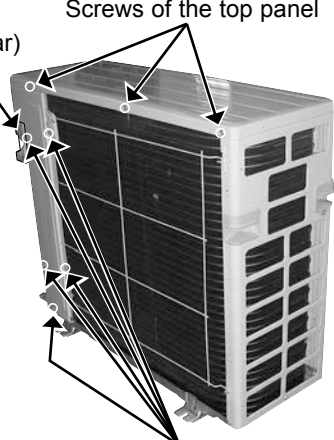
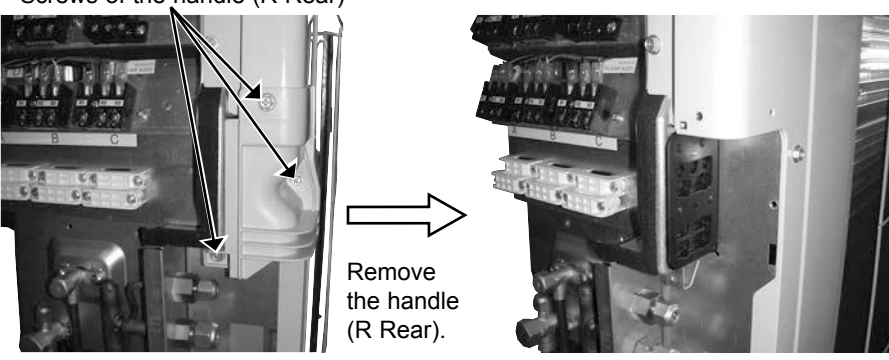
OPERATING PROCEDURE	PHOTOS
<p>1. Removing the panels</p> <p>(1) Remove the screws fixing the service panel, and remove the service panel.</p> <p>(2) Remove the screws fixing the top panel and remove the top panel.</p> <p>(3) Remove the screws fixing the handle (R Rear), and remove the handle (R Rear).</p> <p>(4) Disconnect the power supply and indoor/outdoor connecting wire.</p> <p>(5) Remove the screws fixing the front panel, and remove the front panel.</p> <p>(6) Remove the screws fixing the back panel, and remove the back panel.</p>	<p>Photo 1</p> <p>Screws of the top panel</p>  <p>Screws of the service panel</p>
<p>Photo 3</p> <p>Catch of the front panel</p> <p>Screws of the front panel</p>  <p>Screws of the front panel</p>	<p>Photo 2</p> <p>Screws of the top panel</p> <p>Handle (R Rear)</p>  <p>Screws of the back panel</p>
<p>Photo 4</p> <p>Screws of the handle (R Rear)</p>  <p>Remove the handle (R Rear).</p>	

OPERATING PROCEDURE

2. Removing the outdoor control P.C. board, the reactor and the outdoor power P.C. board

- (1) Remove the service panel and the top panel (Refer to 1).
- (2) Disconnect the power supply and indoor/outdoor connecting wire.
- (3) Disconnect the connectors on the outdoor control P.C. board.
- (4) Remove the screws fixing the outdoor control P.C. board holder, and remove the outdoor control P.C. board.
- (5) Disconnect the lead wire from the reactor.
- (6) Remove the screws fixing the reactor, and remove the reactor.
- (7) Disconnect the lead wire of the power P.C. board.
- (8) Disconnect the catches of the PB cover, and remove the PB cover.
- (9) Remove the outdoor power P.C. board.

Photo 7



Screws of the reactor

PHOTOS

Photo 5

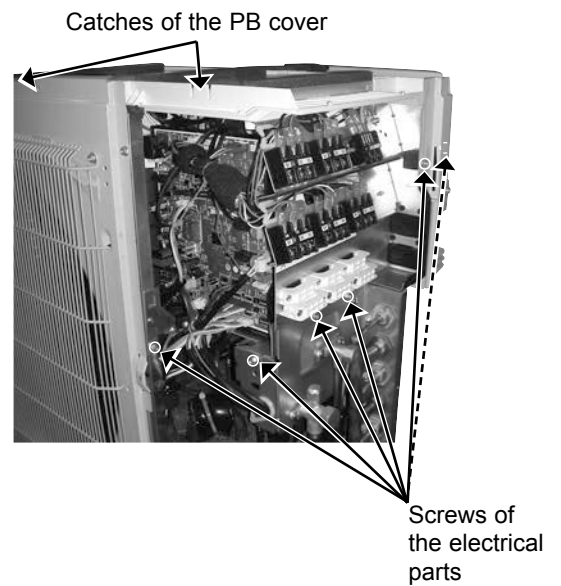
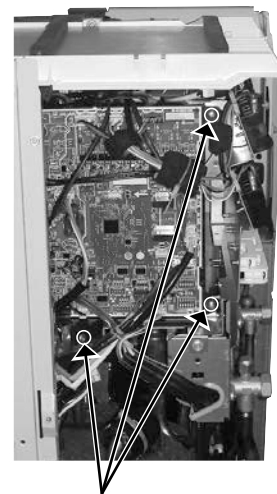

Photo 6



Screws of the outdoor control P.C. board holder

OPERATING PROCEDURE

3. Removing the fan motor

- (1) Remove the service panel, the top panel and the front panel (Refer to 1).
- (2) Disconnect the power supply and indoor/outdoor connecting wire.
- (3) Disconnect the connector CNF1 on the outdoor control P.C. board.
- (4) Remove the propeller fan.
- (5) Remove the fan motor.

4. Removing the expansion valve

- (1) Remove the service panel and the top panel (Refer to 1).
- (2) Disconnect the power supply and indoor/outdoor connecting wire.
(Gas recovery is not required if the unit is pumped down.)
- (3) Remove the LEV coils.
- (4) Detach the brazed parts of the expansion valves and pipes.

PHOTOS

Photo 8

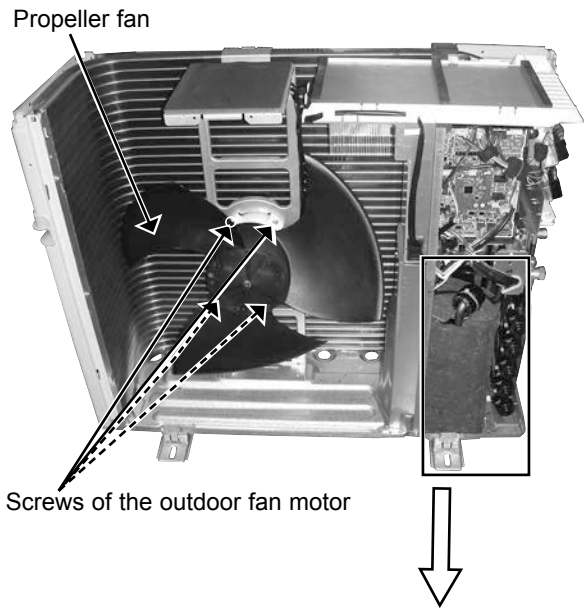
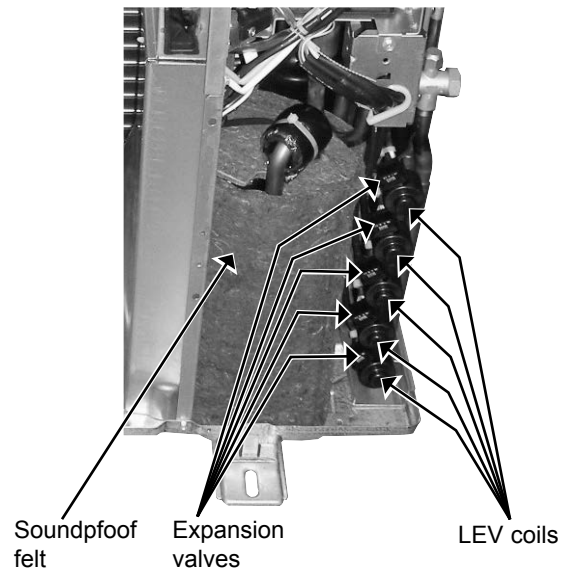

Photo 9



OPERATING PROCEDURE

5. Removing the compressor and 4-way valve

- (1) Remove the service panel, the top panel, the handle (R Rear), the back panel and the front panel (Refer to 1).
- (2) Disconnect the power supply and indoor/outdoor connecting wire, and remove the back panel.
- (3) Recover gas from the refrigerant circuit.

NOTE: Recover gas from the pipes until the pressure gauge shows 0 kg/cm² (0 MPa).

- (4) Disconnect the compressor lead wire from the terminal of the compressor (U, V, W).
- (5) Disconnect the outdoor control P.C. board connectors: CNF1, CNTH1, CNTH2, CN63H, CN712, CN791, CN792, CN793, CN794, CN795 (**MXZ-5E**)
- (6) Remove the screws fixing the electrical parts, and remove the electrical parts (Photo 5).
- (7) Remove the propeller fan.
- (8) Remove the screws fixing the separator, and remove the separator.
- (9) Remove the soundproof felt.
- (10) Detach the brazed parts of the compressor suction pipe and discharge pipe.
- (11) Remove the compressor nuts and remove the compressor.
- (12) Detach the brazed parts of 4-way valve and pipes.

PHOTOS

Photo 10

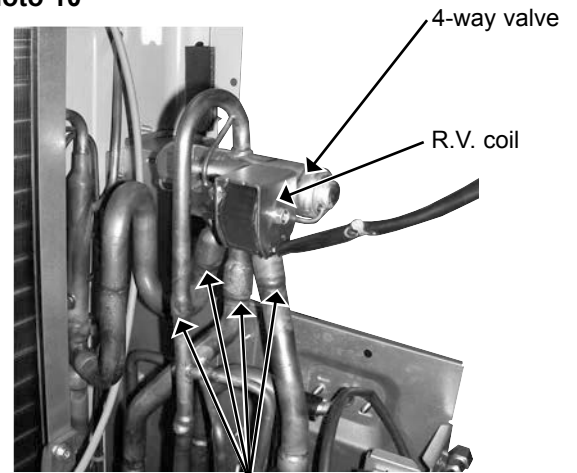

Brazed parts of 4-way valve and pipes

Photo 11

Discharge pipe brazed part

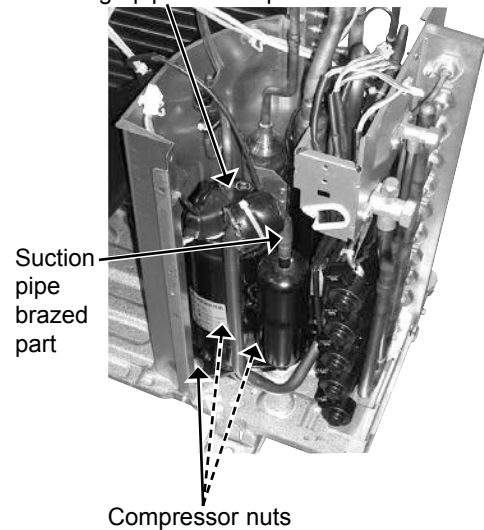

Suction pipe brazed part

Compressor nuts

12-3. MXZ-2E53VAHZ

NOTE: Turn OFF the power supply before disassembly.

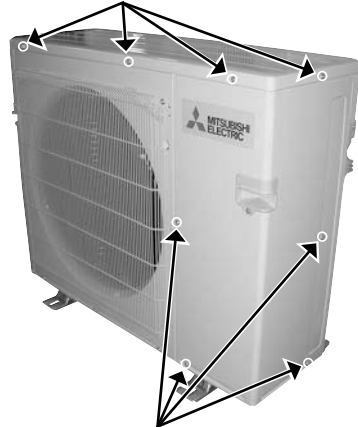
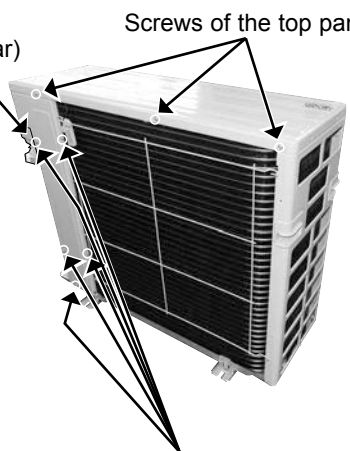
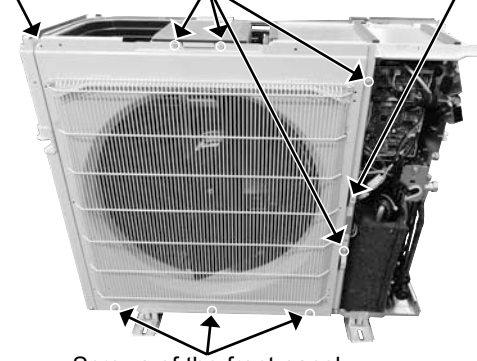
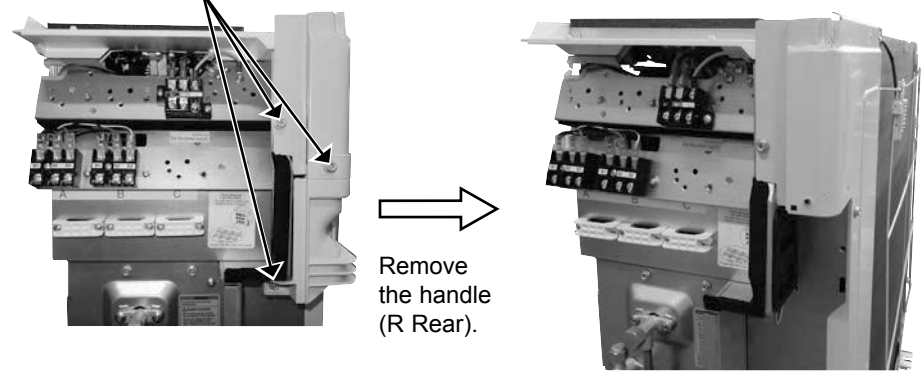
OPERATING PROCEDURE	PHOTOS
<p>1. Removing the panels</p> <p>(1) Remove the screws fixing the service panel, and remove the service panel.</p> <p>(2) Remove the screws fixing the top panel and remove the top panel.</p> <p>(3) Remove the screws fixing the handle (R Rear), and remove the handle (R Rear).</p> <p>(4) Disconnect the power supply and indoor/outdoor connecting wire.</p> <p>(5) Remove the screws fixing the front panel, and remove the front panel.</p> <p>(6) Remove the screws fixing the back panel, and remove the back panel.</p>	<p>Photo 1</p> <p>Screws of the top panel</p>  <p>Screws of the service panel</p> <p>Photo 2</p> <p>Handle (R Rear)</p> <p>Screws of the top panel</p>  <p>Screws of the back panel</p> <p>Photo 3</p> <p>Catch of the front panel</p> <p>Screws of the front panel</p>  <p>Screws of the front panel</p> <p>Photo 4</p> <p>Screws of the handle (R Rear)</p>  <p>Remove the handle (R Rear).</p>

OPERATING PROCEDURE

2. Removing the outdoor control P.C. board, the reactor and the outdoor power P.C. board

- (1) Remove the service panel and the top panel (Refer to 1).
- (2) Disconnect the power supply and indoor/outdoor connecting wire.
- (3) Disconnect the connectors on the outdoor control P.C. board.
- (4) Remove the screws fixing the outdoor control P.C. board holder, and remove the outdoor control P.C. board.
- (5) Disconnect the lead wire from the reactor.
- (6) Remove the screws fixing the reactor, and remove the reactor.
- (7) Disconnect the lead wire of the power P.C. board.
- (8) Disconnect the catches of the PB cover, and remove the PB cover.
- (9) Remove the outdoor power P.C. board.

Photo 7



Screws of the reactor

PHOTOS

Photo 5

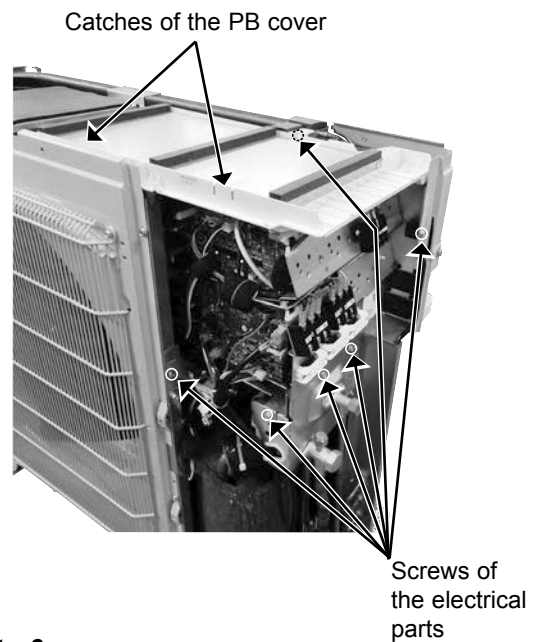
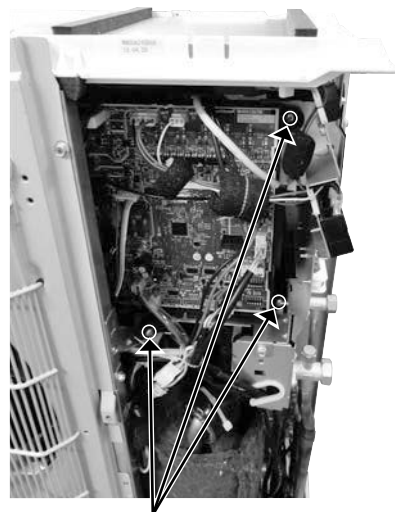

Photo 6



Screws of the outdoor control P.C. board holder

OPERATING PROCEDURE

3. Removing the fan motor

- (1) Remove the service panel, the top panel and the front panel (Refer to 1).
- (2) Disconnect the power supply and indoor/outdoor connecting wire.
- (3) Disconnect the connector CNF1 on the outdoor control P.C. board.
- (4) Remove the propeller fan.
- (5) Remove the fan motor.

4. Removing the expansion valve

- (1) Remove the service panel and the top panel (Refer to 1).
- (2) Disconnect the power supply and indoor/outdoor connecting wire.
(Gas recovery is not required if the unit is pumped down.)
- (3) Remove the LEV coils.
- (4) Detach the brazed parts of the expansion valves and pipes.

5. Removing the defrost heater

- (1) Remove the service panel, the top panel and the front panel (Refer to 1.).
- (2) Disconnect the power supply and indoor/outdoor connecting wire.
- (3) Disconnect the defrost heater lead wires from CN714 on the outdoor control P.C. board.
- (4) Remove the defrost heater lead wires from the lead clamp.
- (5) Remove the screws of the defrost heater.
- (6) Remove the heater protector and the defrost heater.

PHOTOS

Photo 8

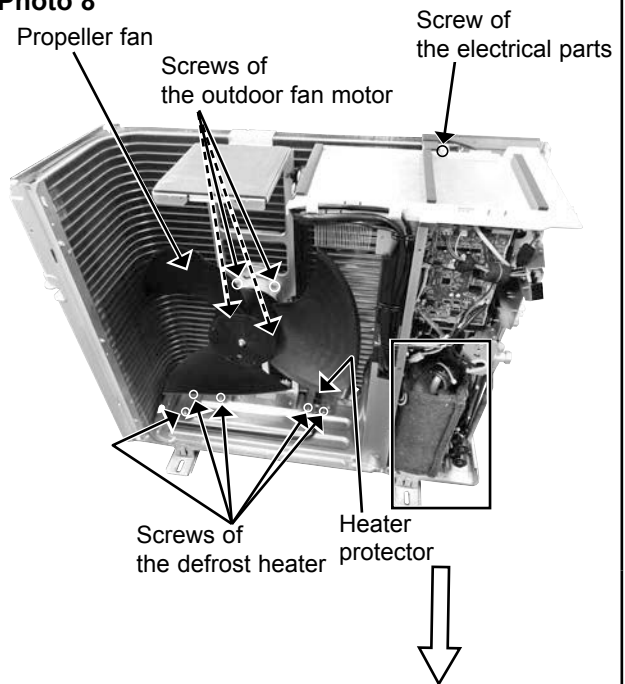
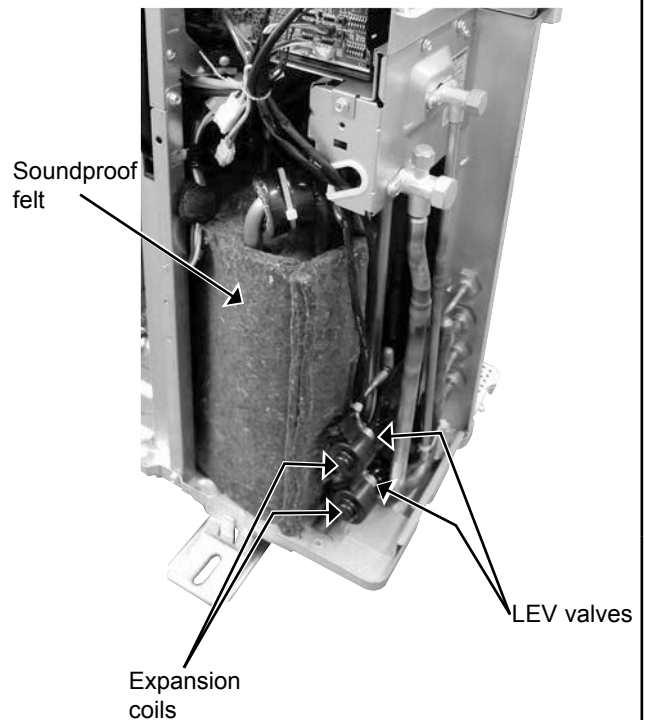

Photo 9



OPERATING PROCEDURE

6. Removing the compressor and 4-way valve

- (1) Remove the service panel, the top panel, the handle (R Rear), the back panel and the front panel (Refer to 1).
- (2) Disconnect the power supply and indoor/outdoor connecting wire, and remove the back panel.
- (3) Recover gas from the refrigerant circuit.

NOTE: Recover gas from the pipes until the pressure gauge shows 0 kg/cm² (0 MPa).

- (4) Disconnect the compressor lead wire from the terminal of the compressor (U, V, W).
- (5) Disconnect the outdoor control P.C. board connectors: CNF1, CNTH1, CNTH2, CN63H, CN712, CN791, CN792
- (6) Remove the screws fixing the electrical parts, and remove the electrical parts (Photo 5).
- (7) Remove the propeller fan.
- (8) Remove the screws fixing the separator, and remove the separator.
- (9) Remove the soundproof felt.
- (10) Detach the brazed parts of the compressor suction pipe and discharge pipe.
- (11) Remove the compressor nuts and remove the compressor.
- (12) Detach the brazed parts of 4-way valve and pipes.

PHOTOS

Photo 10

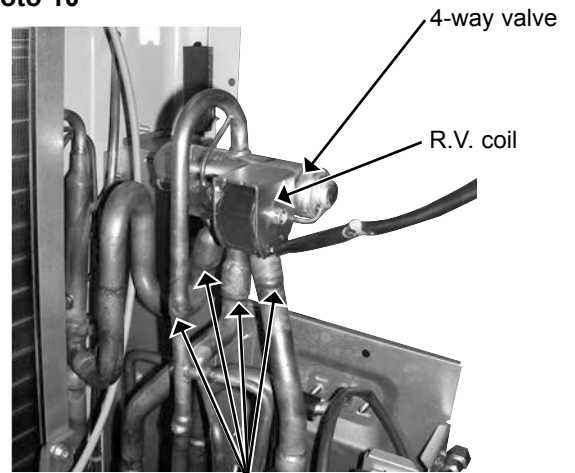

Brazed parts of 4-way valve and pipes

Photo 11

Discharge pipe brazed part

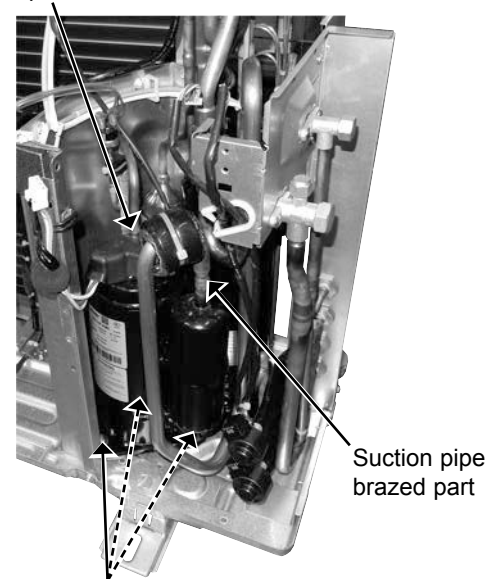

Compressor nuts

12-4. MXZ-4E83VAHZ

NOTE: Turn OFF the power supply before disassembly.

OPERATING PROCEDURE

1. Removing the panels

- (1) Remove the screws fixing the service panel, and remove the service panel.
- (2) Remove the screws fixing the top panel, remove the top panel.
- (3) Disconnect the power supply and indoor/outdoor connecting wire.
- (4) Remove the screws fixing the front panel, and remove the front panel.
- (5) Remove the screws fixing the back panel, and remove the back panel.

Photo 3

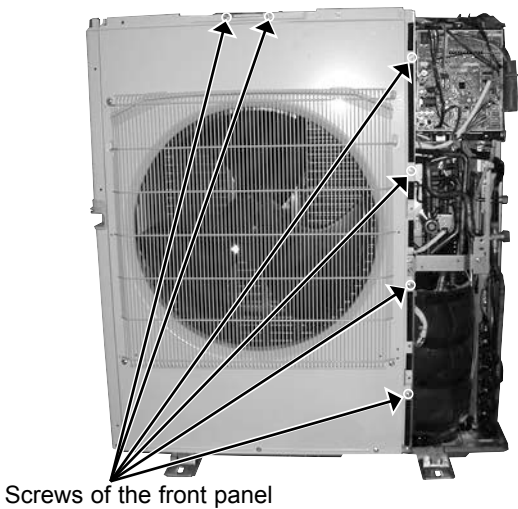

PHOTOS

Photo 1

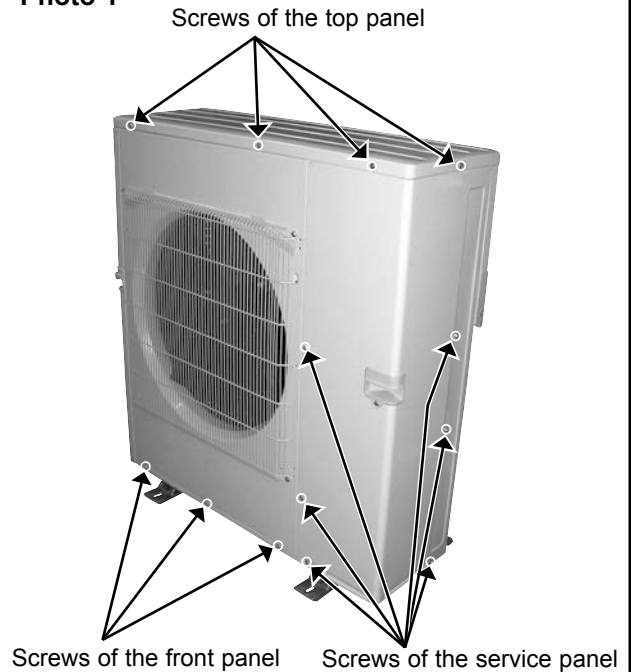
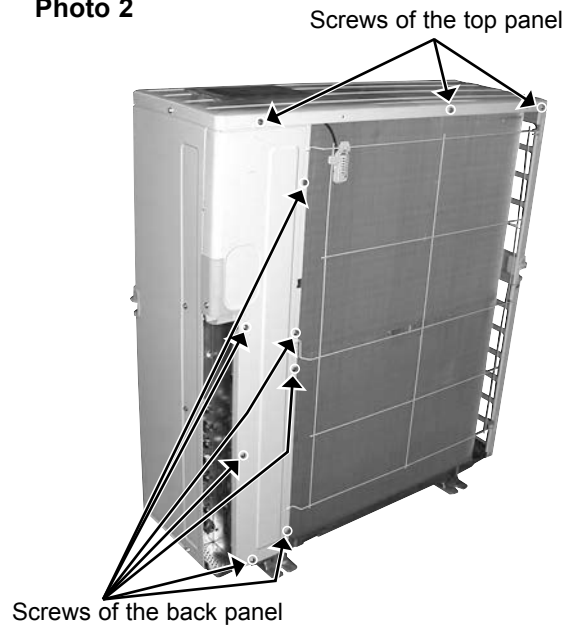

Photo 2



OPERATING PROCEDURE

2. Removing the outdoor control P.C. board, the reactor and the outdoor power P.C. board

- (1) Remove the service panel, the top panel and the front panel (Refer to 1).
- (2) Disconnect the power supply and indoor/outdoor connecting wire.
- (3) Disconnect the connectors on the outdoor control P.C. board.
- (4) Remove the screws fixing the outdoor control P.C. board, and remove the outdoor control P.C. board.
- (5) Remove the screws fixing the electrical parts, and remove the electrical parts.
- (6) Remove the screws fixing the TB support, and remove the TB support.
- (7) Remove the screws fixing the control box separator, and remove the control box separator.
- (8) Disconnect the lead wire of the outdoor power P.C. board.
- (9) Remove the screws fixing the outdoor power P.C. board, and remove the outdoor power P.C. board with the outdoor P.C. board holder.
- (10) Remove the screws fixing the control box F, and remove the control box F.
- (11) Remove the screws fixing the reactors, and remove the reactors.

Photo 7

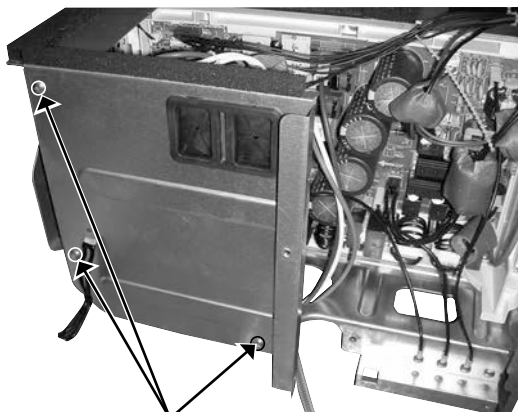

Screws of the control box F

Photo 8

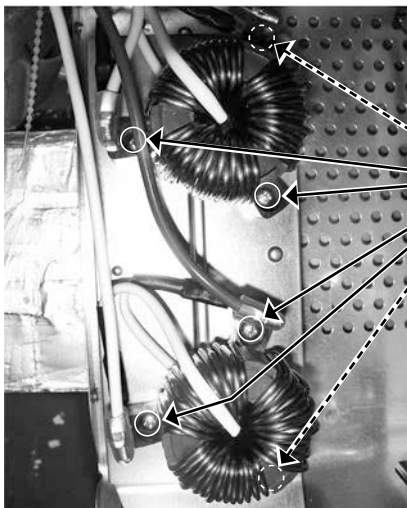

Screws of the reactor

PHOTOS

Photo 4

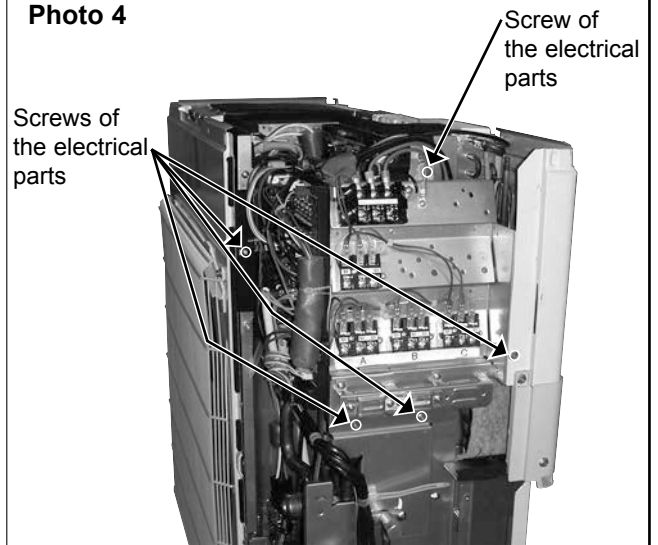

Screw of the electrical parts

Screws of the electrical parts

Photo 5

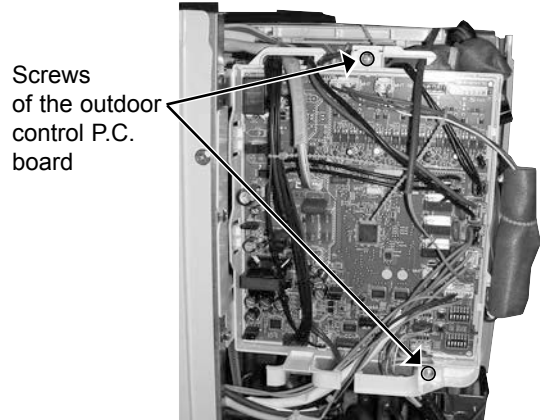

Screws of the outdoor control P.C. board

Photo 6

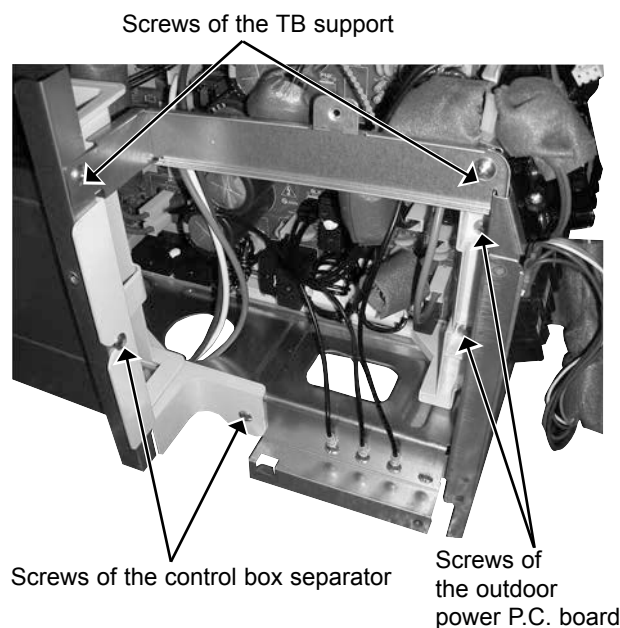

Screws of the TB support

Screws of the control box separator

Screws of the outdoor power P.C. board

OPERATING PROCEDURE

3. Removing the fan motor

- (1) Remove the service panel, the top panel and the front panel (Refer to 1).
- (2) Disconnect the power supply and indoor/outdoor connecting wire.
- (3) Disconnect the connector CNF1 on the outdoor control P.C. board.
- (4) Remove the propeller fan.
- (5) Remove the fan motor.

4. Removing the expansion valve

- (1) Remove the service panel and the top panel (Refer to 1).
- (2) Disconnect the power supply and indoor/outdoor connecting wire.
(Gas recovery is not required if the unit is pumped down.)
- (3) Remove the LEV coils.
- (4) Detach the brazed parts of expansion valves and pipes.

5. Removing the defrost heater

- (1) Remove the service panel, the top panel and the front panel (Refer to 1.).
- (2) Disconnect the power supply and indoor/outdoor connecting wire.
- (3) Disconnect the defrost heater lead wires from CN714 on the outdoor control P.C. board.
- (4) Remove the defrost heater lead wires from the lead clamp.
- (5) Remove the screws of the defrost heater.
- (6) Remove the heater protector and the defrost heater.

PHOTOS

Photo 9

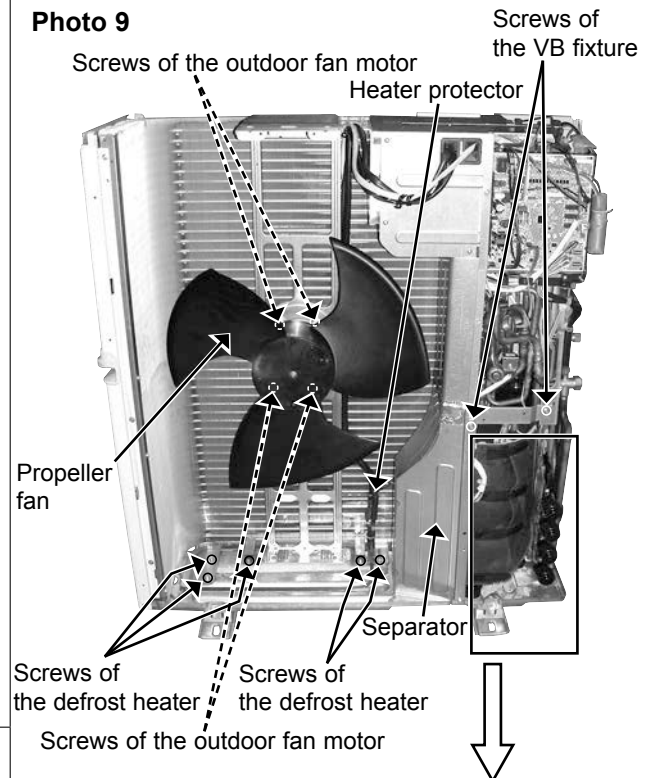
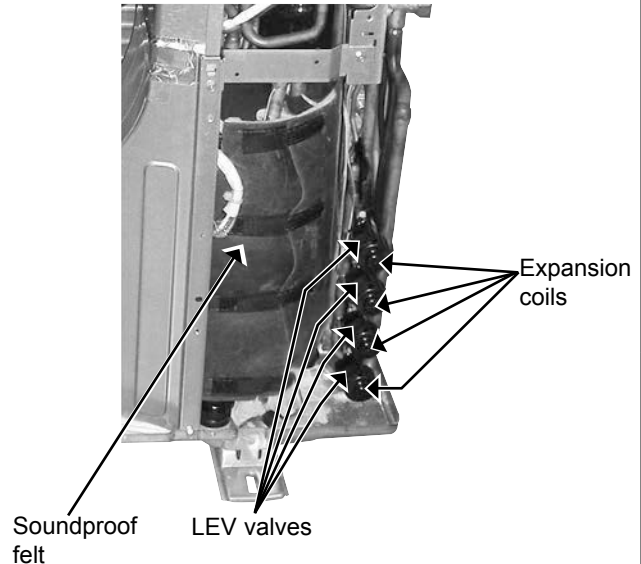

Photo 10



OPERATING PROCEDURE

6. Removing the compressor and 4-way valve

- (1) Remove the service panel, the top panel, the back panel and the front panel (Refer to 1).
- (2) Disconnect the power supply and indoor/outdoor connecting wire, and remove the back panel.
- (3) Recover gas from the refrigerant circuit.

NOTE: Recover gas from the pipes until the pressure gauge shows 0 kg/cm² (0 MPa).

- (5) Disconnect the compressor lead wire from the terminal of the compressor (U, V, W).
- (6) Disconnect the outdoor control P.C. board connectors: CNF1, CNTH1, CNTH2, CN63H, CN712, CN713, CN714, CN791, CN792, CN793, CN794
- (7) Remove the screws fixing the electrical parts, and remove the electrical parts (Photo 4).
- (8) Remove the propeller fan.
- (9) Remove the screws fixing the VB fixture, and remove the VB fixture.
- (10) Remove the screws fixing the separator, and remove the separator.

NOTE: When installing the separator, insert the tabs of the heat exchanger into the separator.

- (11) Remove the soundproof felt.
- (12) Detach the brazed parts of the suction pipe and discharge pipe.
- (13) Remove the nuts of the compressor, and remove the compressor.
- (14) Detach the brazed parts of 4-way valve and pipes.

PHOTOS

Photo 11



4-way valve

R.V. coil

Brazed parts of 4-way valve and pipes

Photo 12

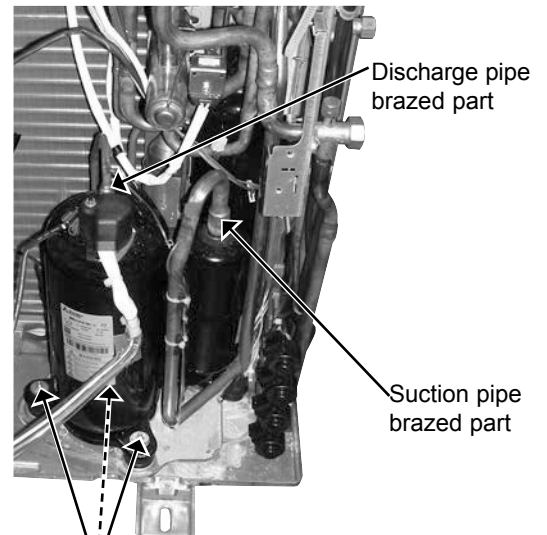

Discharge pipe brazed part

Suction pipe brazed part

Compressor nuts

mitsubishi electric corporation

HEAD OFFICE: TOKYO BUILDING, 2-7-3, MARUNOUCHI, CHIYODA-KU, TOKYO 100-8310, JAPAN

© Copyright 2015 MITSUBISHI ELECTRIC CORPORATION

Issued: Feb. 2017. No.OBH723 REVISED EDITION-D

Issued: Feb. 2016. No.OBH723 REVISED EDITION-C

Issued: Nov. 2015. No.OBH723 REVISED EDITION-B

Issued: Sep. 2015. No.OBH723 REVISED EDITION-A

Published: Apr. 2015. No.OBH723

Made in Japan

Specifications are subject to change without notice.