

**Revision A:**

• MUZ-HJ50VA-**E1** has been added.

Please void OBH648.

# OUTDOOR UNIT SERVICE MANUAL



**No. OBH648**  
REVISED EDITION-A

## Models

**MUZ-HJ25VA** - **E1**

**MUZ-HJ35VA** - **E1**

**MUZ-HJ50VA** - **E1**

Indoor unit service manual  
MSZ-HJ•VA Series (OBH647)

MUZ-HJ25VA  
MUZ-HJ35VA

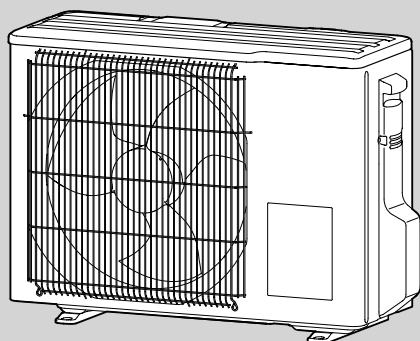

## CONTENTS

1. TECHNICAL CHANGES .....	3
2. PART NAMES AND FUNCTIONS.....	3
3. SPECIFICATION.....	4
4. NOISE CRITERIA CURVES .....	7
5. OUTLINES AND DIMENSIONS .....	8
6. WIRING DIAGRAM.....	9
7. REFRIGERANT SYSTEM DIAGRAM .....	11
8. PERFORMANCE CURVES .....	13
9. ACTUATOR CONTROL.....	24
10. SERVICE FUNCTIONS.....	25
11. TROUBLESHOOTING .....	25
12. DISASSEMBLY INSTRUCTIONS.....	42

**PARTS CATALOG (OBB648)**

**NOTE:**

RoHS compliant products have <G> mark on the spec name plate.



## Use the specified refrigerant only

### Never use any refrigerant other than that specified.

Doing so may cause a burst, an explosion, or fire when the unit is being used, serviced, or disposed of.

Correct refrigerant is specified in the manuals and on the spec labels provided with our products.

We will not be held responsible for mechanical failure, system malfunction, unit breakdown or accidents caused by failure to follow the instructions.

### <Preparation before the repair service>

- Prepare the proper tools.
- Prepare the proper protectors.
- Provide adequate ventilation.
- After stopping the operation of the air conditioner, turn off the power-supply breaker and remove the power plug.
- Discharge the capacitor before the work involving the electric parts.

### <Precautions during the repair service>

- Do not perform the work involving the electric parts with wet hands.
- Do not pour water into the electric parts.
- Do not touch the refrigerant.
- Do not touch the hot or cold areas in the refrigeration cycle.
- When the repair or the inspection of the circuit needs to be done without turning off the power, exercise great caution not to touch the live parts.

### Revision A:

- MUZ-HJ50VA-E1 has been added.

# 1

# TECHNICAL CHANGES

MUZ-HJ25VA -E1

MUZ-HJ35VA -E1

MUZ-HJ50VA -E1

1. New model

# 2

# PART NAMES AND FUNCTIONS

MUZ-HJ25VA MUZ-HJ35VA

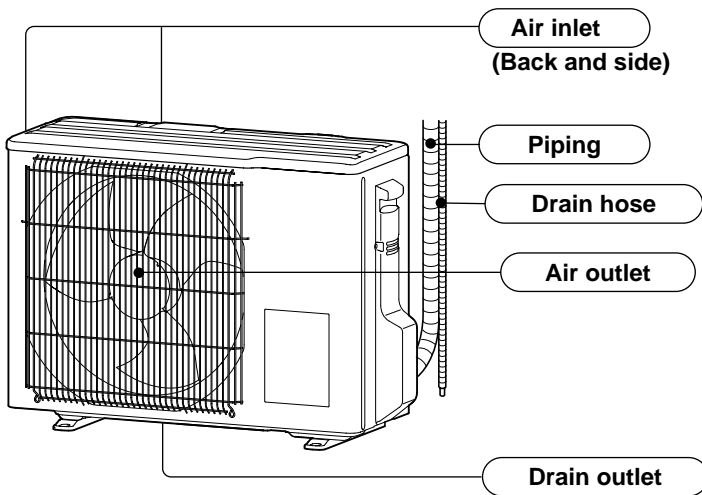

MUZ-HJ50VA

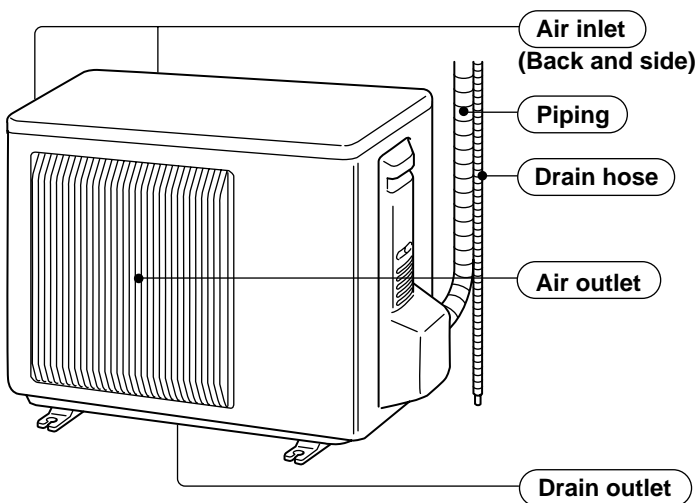

## ACCESSORIES

①	Drain socket	1
---	--------------	---

## 3

## SPECIFICATION

Outdoor model			MUZ-HJ25VA	MUZ-HJ35VA	
Power supply			Single phase, 230 V, 50 Hz		
Capacity Rated frequency (Min.-Max.)	Cooling	kW	2.5 (1.3 - 3.0)	3.15 (1.4 - 3.5)	
	Heating		3.15 (0.9 - 3.5)	3.6 (1.1 - 4.1)	
Breaker Capacity		A	10		
Electrical data	Power input *1 (Total)	Cooling	730	1,040	
		Heating	870	995	
	Running current *1 (Total)	Cooling	3.7	4.9	
		Heating	4.2	4.8	
	Power factor *1 (Total)	Cooling	85	92	
		Heating	90	90	
Starting current *1 (Total)		A	4.2	4.9	
Coefficient of performance (COP) *1 (Total)		Cooling	3.42	3.03	
		Heating	3.62	3.62	
Compressor	Model		KNB065FUJHC	KNB073FUVHC	
	Output		W	500	550
	Current *1	Cooling	A	3.3	4.4
		Heating	A	3.8	4.4
	Refrigeration oil (Model)		L	0.32 (NEO22)	
Fan motor	Model		RA6V21-BD		
	Current *1		A	0.23	
Dimensions W x H x D		mm	699 x 538 x 249		
Weight		kg	24	25	
Special remarks	Dehumidification	Cooling	L/h	0.4	0.6
	Air flow *1		m <sup>3</sup> /h	1,890	1,890
	Sound level *1	Cooling	dB(A)	50	50
		Heating		50	50
	Fan speed		rpm	840	840
	Fan speed regulator			1	1
Refrigerant filling capacity (R410A)		kg	0.70	0.72	

**NOTE:** Test conditions are based on ISO 5151.

Cooling: Indoor Dry-bulb temperature 27°C

Wet-bulb temperature 19°C

Outdoor Dry-bulb temperature 35°C

Heating: Indoor Dry-bulb temperature 20°C

Wet-bulb temperature 6°C

Outdoor Dry-bulb temperature 7°C

Refrigerant piping length (one way): 5 m

\*1 Measured under rated operating frequency.



Outdoor model				<b>MUZ-HJ50VA</b>		
Power supply				Single phase, 230 V, 50 Hz		
Capacity		Cooling	kW	5.0 (1.3 - 5.0)		
Rated frequency (Min.-Max.)		Heating		5.4 (1.4 - 6.5)		
Breaker Capacity			A	12		
Electrical data	Power input *1 (Total)		Cooling	W	2,050	
			Heating		1,480	
	Running current *1 (Total)		Cooling	A	9.0	
			Heating		6.6	
	Power factor *1 (Total)		Cooling	%	99	
			Heating		97	
Starting current *1 (Total)			A	9.0		
Coefficient of performance (COP) *1 (Total)		Cooling		2.44		
		Heating		3.65		
Compressor	Model			SNB130FGBHT		
	Output		W	900		
	Current *1	Cooling		A	8.5	
		Heating			5.9	
	Refrigeration oil (Model)			L	0.45 (NEO22)	
Fan motor	Model			RC0J50-FA		
	Current *1	Cooling		A	0.27	
		Heating			0.34	
Dimensions W x H x D			mm	800 x 550 x 285		
Weight			kg	36		
Special remarks	Dehumidification		Cooling	L/h	2.2	
	Air flow *1	Cooling	High	m <sup>3</sup> /h	1,872	
			Med.		1,872	
			Low		1,086	
		Heating	High		2,088	
			Med.		1,776	
			Low		1,386	
	Sound level *1		Cooling	dB(A)	50	
			Heating		51	
	Fan speed	Cooling	High	rpm	810	
			Med.		810	
			Low		490	
		Heating	High		900	
			Med.		770	
Low			610			
Fan speed regulator				3		
Refrigerant filling capacity (R410A)			kg	1.15		

**NOTE:** Test conditions are based on ISO 5151.

Cooling: Indoor Dry-bulb temperature 27°C

Wet-bulb temperature 19°C

Outdoor Dry-bulb temperature 35°C

Heating: Indoor Dry-bulb temperature 20°C

Wet-bulb temperature 6°C

Outdoor Dry-bulb temperature 7°C

Refrigerant piping length (one way): 5 m

\*1 Measured under rated operating frequency.



**Specifications and rated conditions of main electric parts**

Item	Model	MUZ-HJ25VA	MUZ-HJ35VA
Smoothing capacitor	(C61)	800 $\mu$ F 420 V	
Diode module	(DB61)	15 A 600 V	
	(DB65)	10 A 600 V	
Fuse	(F701, F801)	T3.15AL250V	
Power module	(IC700)	8 A 600 V	10 A 600 V
Expansion valve coil	(LEV)	12 VDC	
Reactor	(L61)	18 mH	
Switching power transistor	(IC821)	30 A 600 V	
Circuit protection	(PTC64)	33 $\Omega$	
Terminal block	(TB)	3 P	
Relay	(X61)	3 A 250 V	
	(X63)	3 A 250 V	
	(X64)	20 A 250 V	
R.V. coil	(21S4)	220 - 240 VAC	

**Specifications and rated conditions of main electric parts**

Item	Model	MUZ-HJ50VA
Smoothing capacitor	(C61, C62, C63)	600 $\mu$ F/ 620 $\mu$ F 420 V
Diode module	(DB61)	15 A 600 V
Fuse	(F61)	T20AL250V
	(F701, F801, F901)	T3.15AL250V
Power module	(IC700)	15 A 600 V
	(IC820)	20A 600V
	(IC932)	8A600V
Expansion valve coil	(LEV)	12 VDC
Reactor	(L61)	23 mH
Circuit protection	(PTC64)	33 $\Omega$
	(PTC65)	33 $\Omega$
Terminal block	(TB)	5 P
Relay	(X63)	3 A 250 V
	(X64)	20 A 250 V
R.V. coil	(21S4)	220 - 240 VAC

# 4

# NOISE CRITERIA CURVES

## MUZ-HJ25VA

FUNCTION	SPL(dB(A))	LINE
COOLING	50	●—●
HEATING	50	○—○

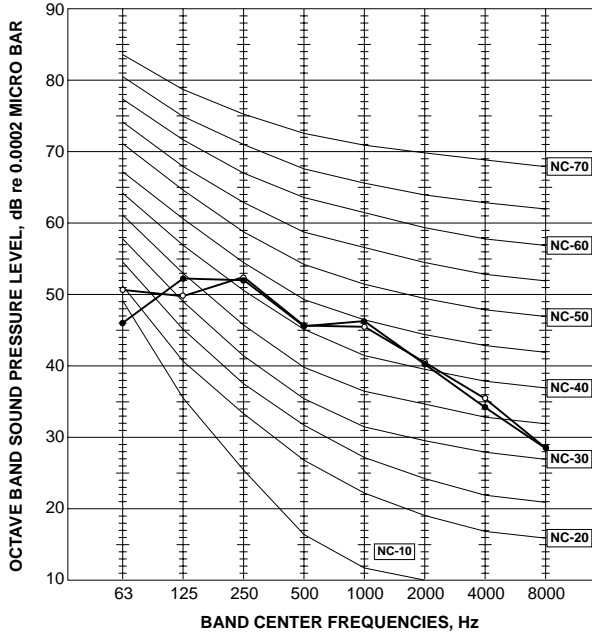

## MUZ-HJ35VA

FUNCTION	SPL(dB(A))	LINE
COOLING	50	●—●
HEATING	50	○—○

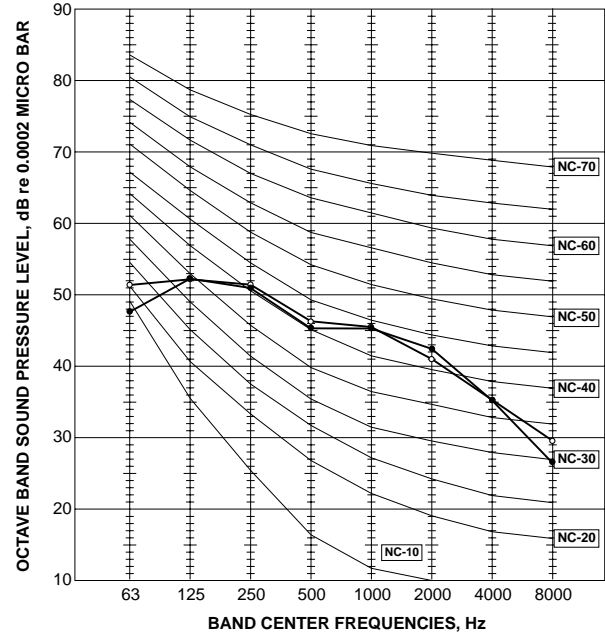

## MUZ-HJ50VA

FUNCTION	SPL(dB(A))	LINE
COOLING	50	●—●
HEATING	51	○—○

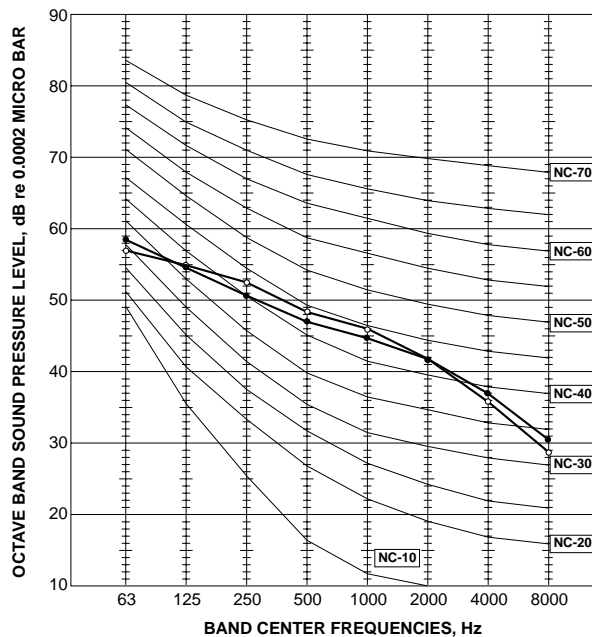

### Test conditions

Cooling : Dry-bulb temperature 35°C

Heating : Dry-bulb temperature 7°C Wet-bulb temperature 6°C

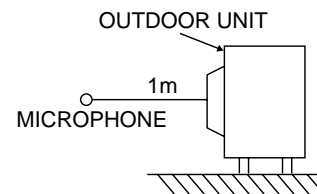

MUZ-HJ25VA MUZ-HJ35VA

Unit : mm

REQUIRED SPACE

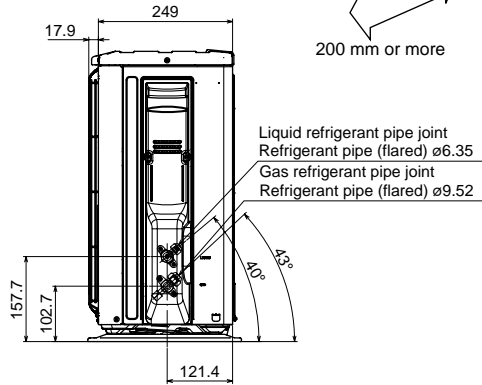
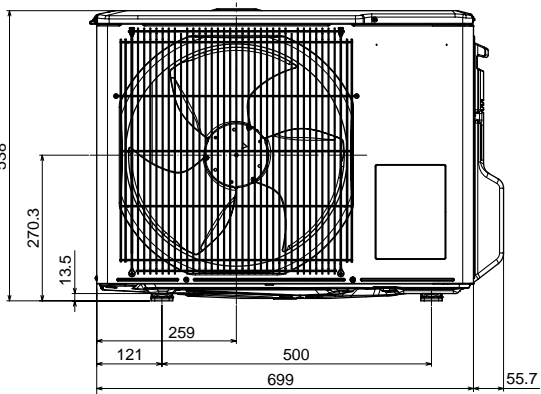
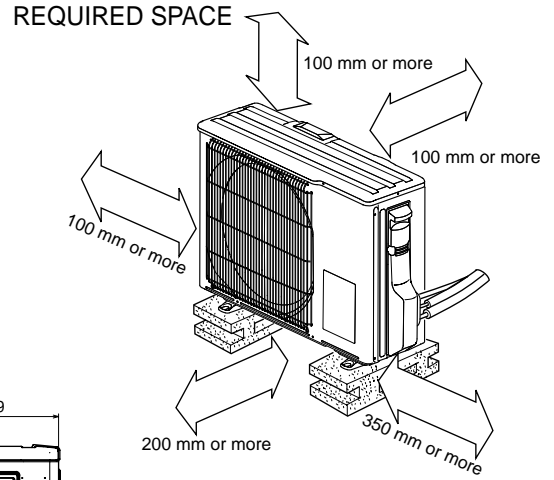
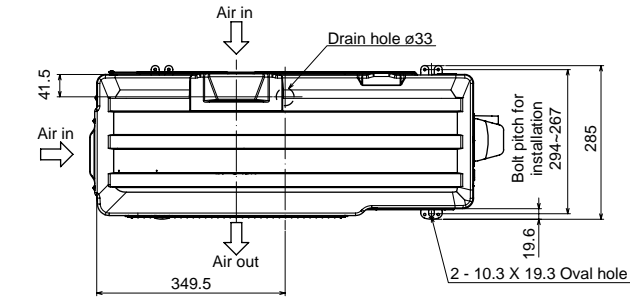

MUZ-HJ50VA

REQUIRED SPACE

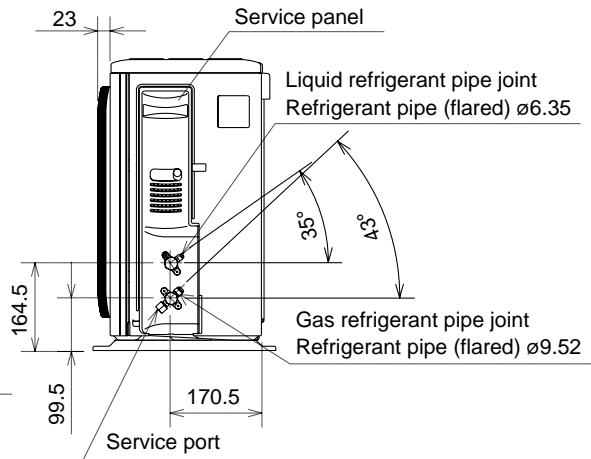
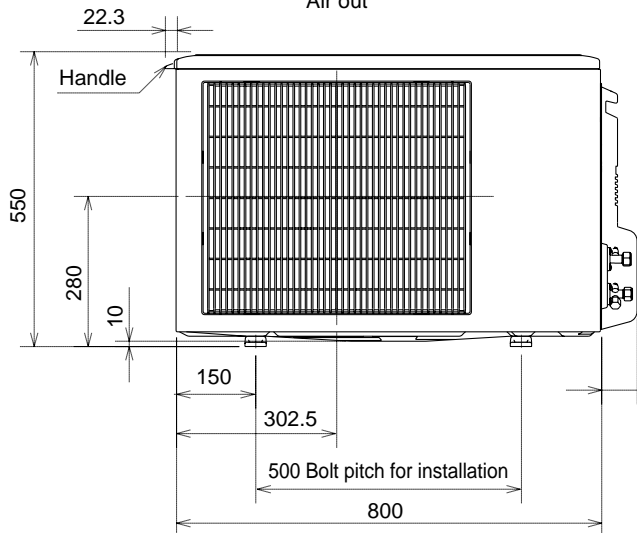
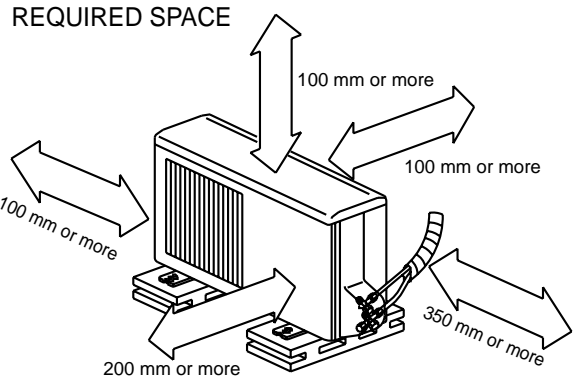
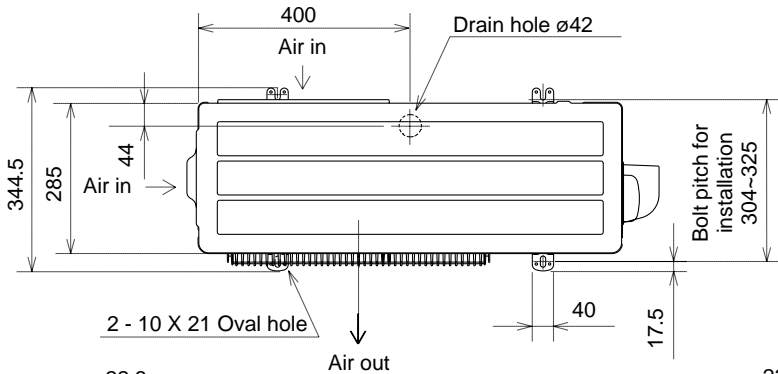



# 6

# WIRING DIAGRAM

## MUZ-HJ25VA

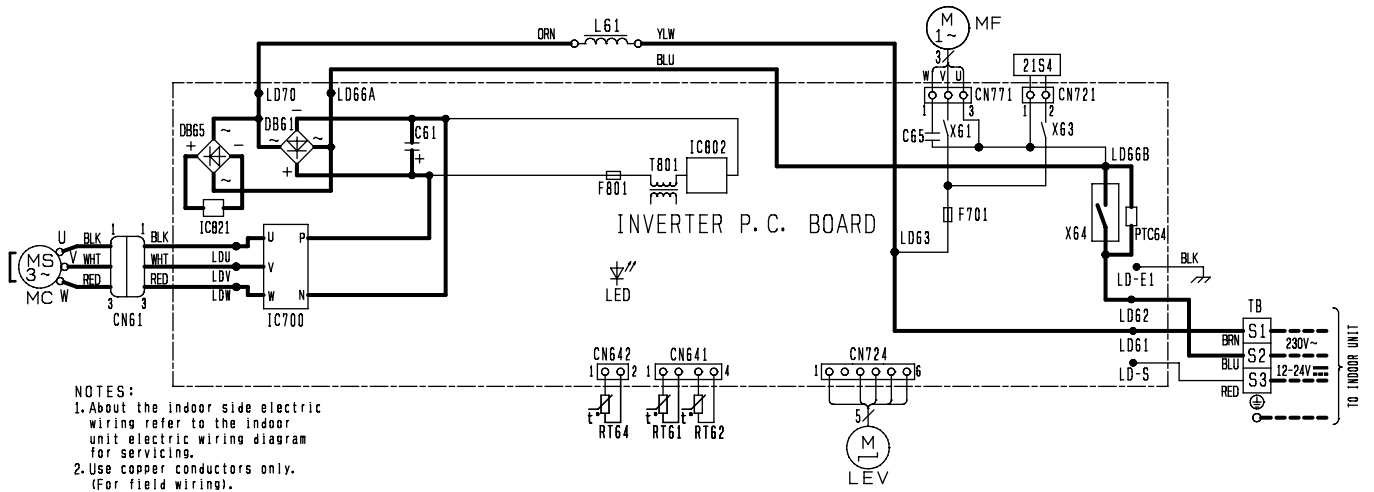

SYMBOL	NAME	SYMBOL	NAME	SYMBOL	NAME
CN61	CONNECTOR	IC821	SWITCHING POWER TRANSISTOR	RT61	DEFROST THERMISTOR
C61	SMOOTHING CAPACITOR	LED	LED	RT62	DISCHARGE TEMP. THERMISTOR
C65	FAN MOTOR CAPACITOR	LEV	EXPANSION VALVE COIL	RT64	FIN TEMP. THERMISTOR
DB61, DB65	DIODE MODULE	L61	REACTOR	TB	TERMINAL BLOCK
F701, F801	FUSE (T3, 15A/250V)	MC	COMPRESSOR	T801	TRANSFORMER
IC700	POWER MODULE	MF	FAN MOTOR (INNER FUSE)	X61, X63, X64	RELAY
IC802	POWER DEVICE	PTC64	CIRCUIT PROTECTION	21S4	REVERSING VALVE COIL

## MUZ-HJ35VA

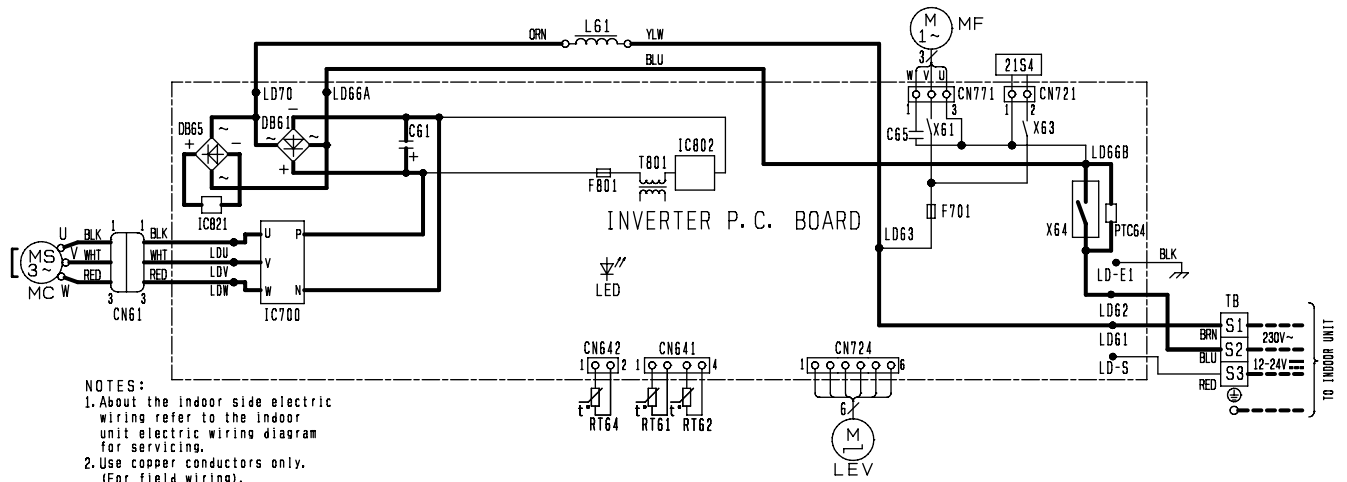

SYMBOL	NAME	SYMBOL	NAME	SYMBOL	NAME
CN61	CONNECTOR	IC821	SWITCHING POWER TRANSISTOR	RT61	DEFROST THERMISTOR
C61	SMOOTHING CAPACITOR	LED	LED	RT62	DISCHARGE TEMP. THERMISTOR
C65	FAN MOTOR CAPACITOR	LEV	EXPANSION VALVE COIL	RT64	FIN TEMP. THERMISTOR
DB61, DB65	DIODE MODULE	L61	REACTOR	TB	TERMINAL BLOCK
F701, F801	FUSE (T3, 15A/250V)	MC	COMPRESSOR	T801	TRANSFORMER
IC700	POWER MODULE	MF	FAN MOTOR (INNER FUSE)	X61, X63, X64	RELAY
IC802	POWER DEVICE	PTC64	CIRCUIT PROTECTION	21S4	REVERSING VALVE COIL

# MUZ-HJ50VA

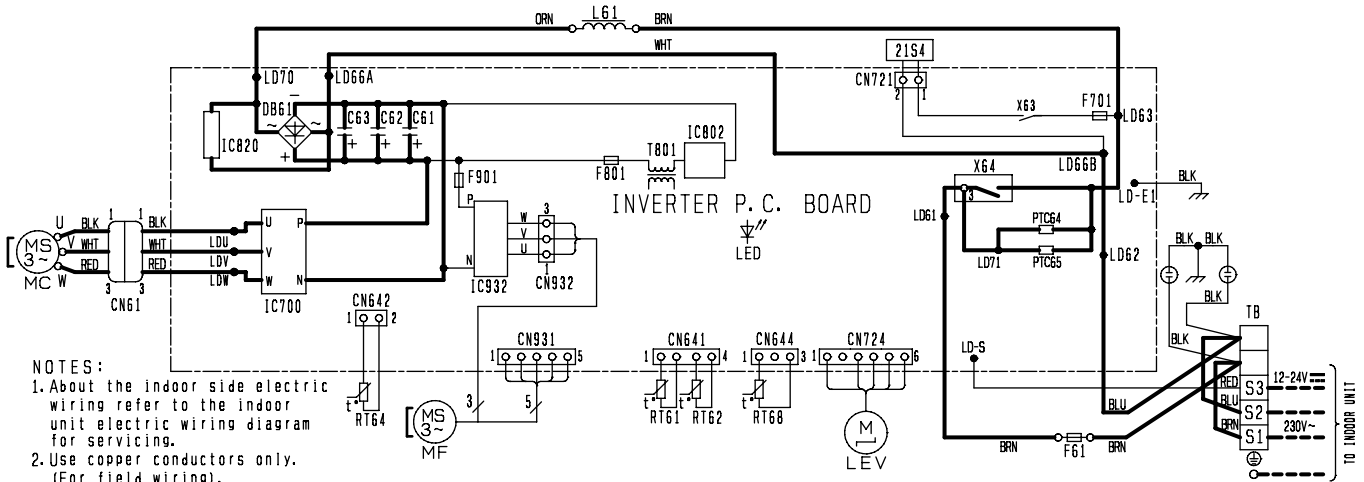

SYMBOL	NAME	SYMBOL	NAME	SYMBOL	NAME
CN61	CONNECTOR	LEV	EXPANSION VALVE COIL	RT68	OUTDOOR HEAT EXCHANGER TEMP. THERMISTOR.
C61, C62, C63	SMOOTHING CAPACITOR	L61	REACTOR	TB	TERMINAL BLOCK
DB61	DIODE MODULE	MC	COMPRESSOR	T801	TRANSFORMER
F61	FUSE (T20AL250V)	MF	FAN MOTOR	X63, X64	RELAY
F701, F801, F901	FUSE (T3.15AL250V)	PTC64, PTC65	CIRCUIT PROTECTION	21S4	REVERSING VALVE COIL
IC700, IC820, IC932	POWER MODULE	RT61	DEFROST THERMISTOR		
IC802	POWER DEVICE	RT62	DISCHARGE TEMP. THERMISTOR		
LED	LED	RT64	FIN TEMP. THERMISTOR		

# 7

# REFRIGERANT SYSTEM DIAGRAM

MUZ-HJ25VA MUZ-HJ35VA

Unit : mm

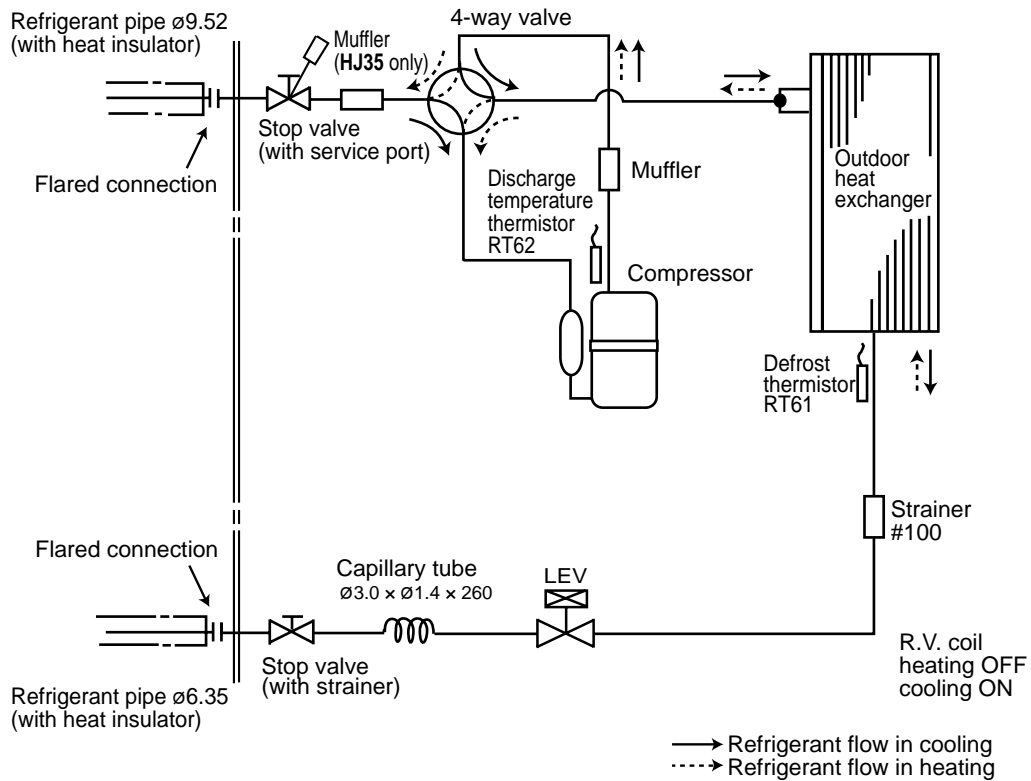

MUZ-HJ50VA

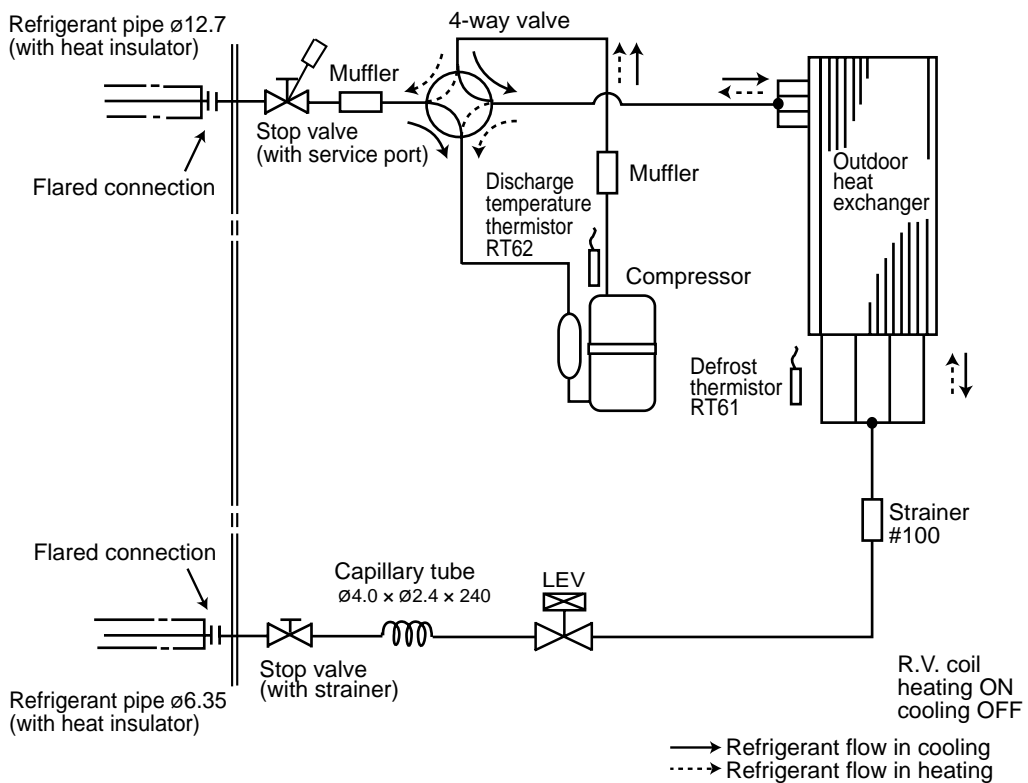

## MAX. REFRIGERANT PIPING LENGTH and MAX. HEIGHT DIFFERENCE

	Refrigerant piping: m		Piping size O.D: mm	
	Max. Length A	Max. Height difference B	Gas	Liquid
			9.52	6.35
<b>MUZ-HJ25VA</b> <b>MUZ-HJ35VA</b>	20	12	12.7	
<b>MUZ-HJ50VA</b>				

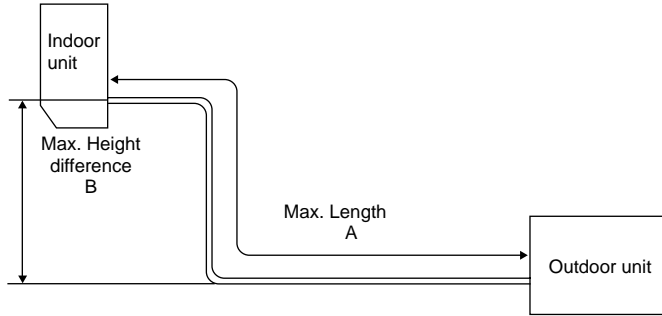

## ADDITIONAL REFRIGERANT CHARGE (R410A : g)

Model	Outdoor unit precharged	Refrigerant piping length (one way)											
		5 m	6 m	7 m	8 m	9 m	10 m	11 m	12 m	13 m	14 m	15 m	20 m
<b>MUZ-HJ25VA</b>	700	0	0	0	20	40	60	80	100	120	140	160	260
<b>MUZ-HJ35VA</b>	720												
<b>MUZ-HJ50VA</b>	1,150												

Calculation:  $X \text{ g} = 20 \text{ g/m} \times (\text{Refrigerant piping length (m)} - 7)$

**NOTE :** Refrigerant piping exceeding 7 m requires additional refrigerant charge according to the calculation.

**MUZ-HJ25VA MUZ-HJ35VA MUZ-HJ50VA**

The standard specifications apply only to the operation of the air conditioner under normal conditions. Since operating conditions vary according to the areas where these units are installed, the following information has been provided to clarify the operating characteristics of the air conditioner under the conditions indicated by the performance curve.

**(1) GUARANTEED VOLTAGE**

198 ~ 264 V, 50 Hz

**(2) AIR FLOW**

Air flow should be set at MAX.

**(3) MAIN READINGS**

(1) Indoor intake air wet-bulb temperature :	°C WB	} Cooling
(2) Indoor outlet air wet-bulb temperature :	°C WB	
(3) Outdoor intake air dry-bulb temperature :	°C DB	
(4) Total input:	W	
(5) Indoor intake air dry-bulb temperature :	°C DB	} Heating
(6) Outdoor intake air wet-bulb temperature :	°C WB	
(7) Total input :	W	

Indoor air wet and dry bulb temperature difference on the left side of the following chart shows the difference between the indoor intake air wet and dry bulb temperature and the indoor outlet air wet and dry bulb temperature for your reference at service.

**How to measure the indoor air wet and dry bulb temperature difference**

1. Attach at least 2 sets of wet and dry bulb thermometers to the indoor air intake as shown in the figure, and at least 2 sets of wet and dry bulb thermometers to the indoor air outlet. The thermometers must be attached to the position where air speed is high.
2. Attach at least 2 sets of wet and dry bulb thermometers to the outdoor air intake.  
Cover the thermometers to prevent direct rays of the sun.
3. Check that the air filter is cleaned.
4. Open windows and doors of room.
5. Press the EMERGENCY OPERATION switch once (twice) to start the EMERGENCY COOL (HEAT) MODE.
6. When system stabilizes after more than 15 minutes, measure temperature and take an average temperature.
7. 10 minutes later, measure temperature again and check that the temperature does not change.

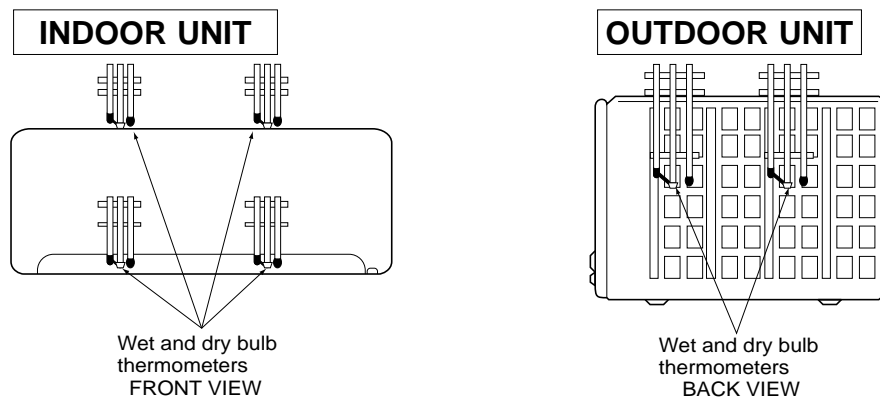

## 8-1. CAPACITY AND INPUT CURVES

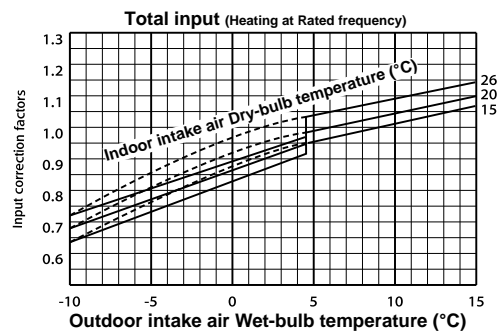
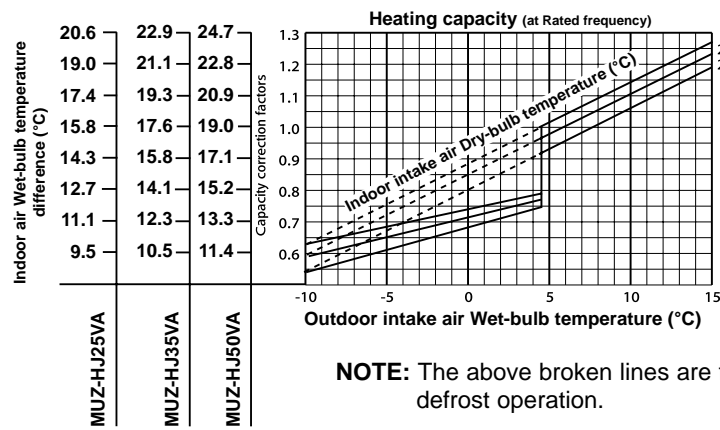
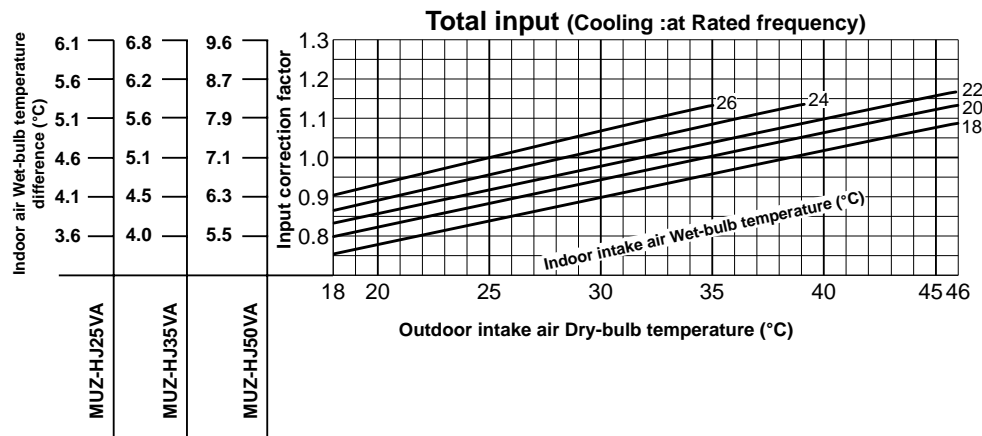
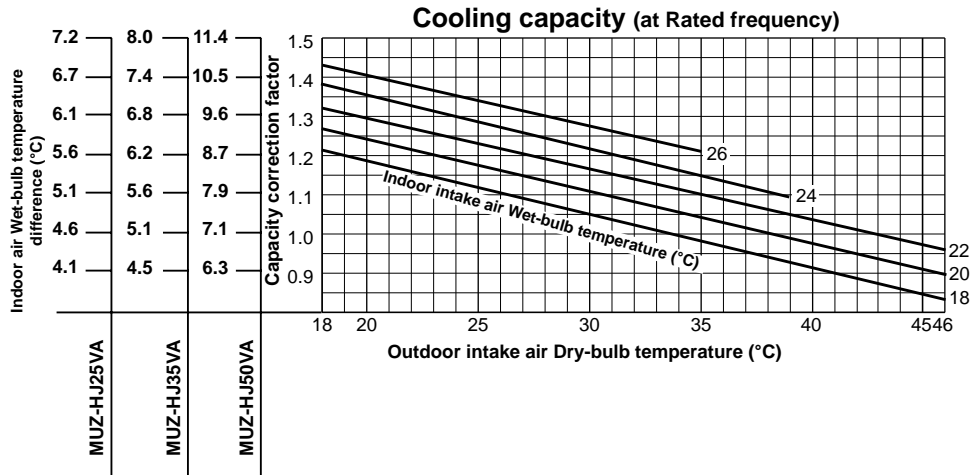

NOTE: The above broken lines are for the heating operation without any frost and defrost operation.

## 8-2. CAPACITY AND INPUT CORRECTION BY OPERATIONAL FREQUENCY OF COMPRESSOR

### MUZ-HJ25VA

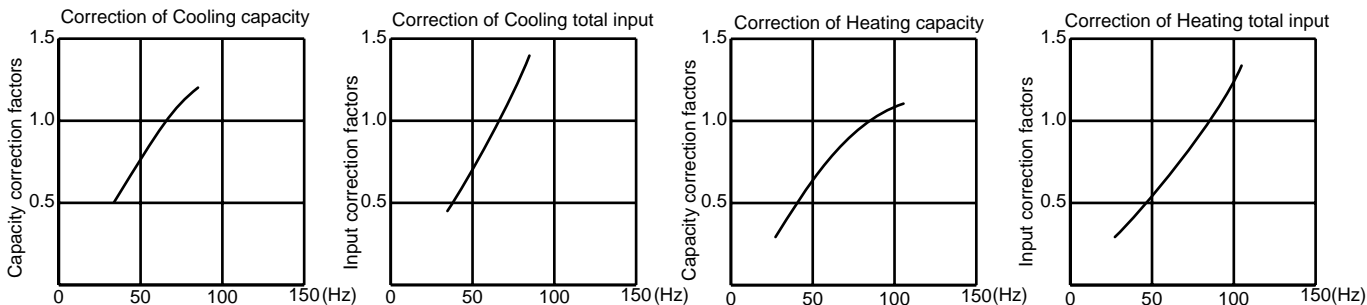

The operational frequency of compressor    The operational frequency of compressor    The operational frequency of compressor    The operational frequency of compressor

### MUZ-HJ35VA

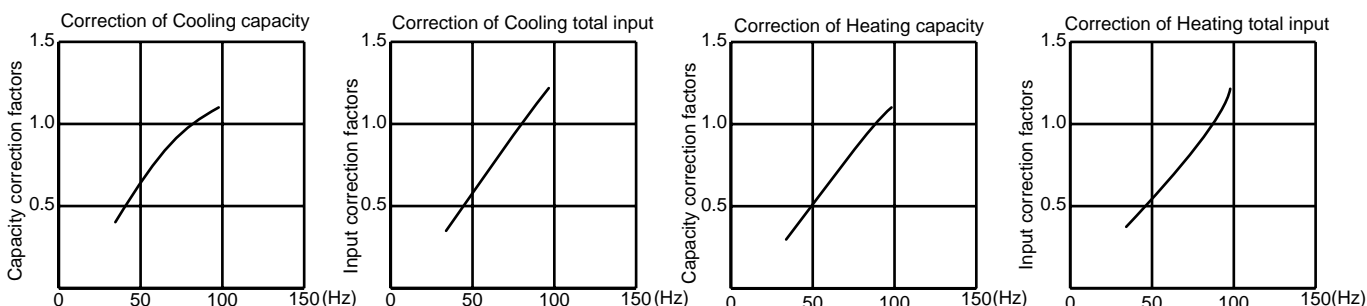

The operational frequency of compressor    The operational frequency of compressor    The operational frequency of compressor    The operational frequency of compressor

### MUZ-HJ50VA

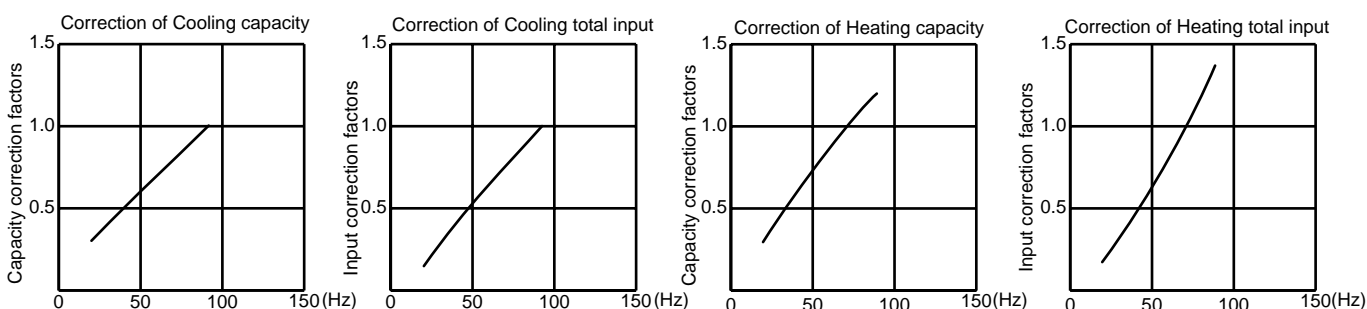

The operational frequency of compressor    The operational frequency of compressor    The operational frequency of compressor    The operational frequency of compressor

## 8-3. HOW TO OPERATE FIXED-FREQUENCY OPERATION

<Test run operation>

1. Press EMERGENCY OPERATION switch to start COOL or HEAT mode (COOL: Press once, HEAT: Press twice).
2. Test run operation starts and continues to operate for 30 minutes.
3. Compressor operates at rated frequency in COOL mode or 58 Hz in HEAT mode.
4. Indoor fan operates at High speed.
5. After 30 minutes, test run operation finishes and EMERGENCY OPERATION starts (operation frequency of compressor varies).
6. To cancel test run operation (EMERGENCY OPERATION), press EMERGENCY OPERATION switch or any button on remote controller.

## 8-4. OUTDOOR LOW PRESSURE AND OUTDOOR UNIT CURRENT

### COOL operation

- ① Both indoor and outdoor unit are under the same temperature/humidity condition.
- ② Operation: TEST RUN OPERATION (Refer to 8-3.)

Dry-bulb temperature (°C)	Relative humidity (%)
20	50
25	60
30	70

### Outdoor low pressure

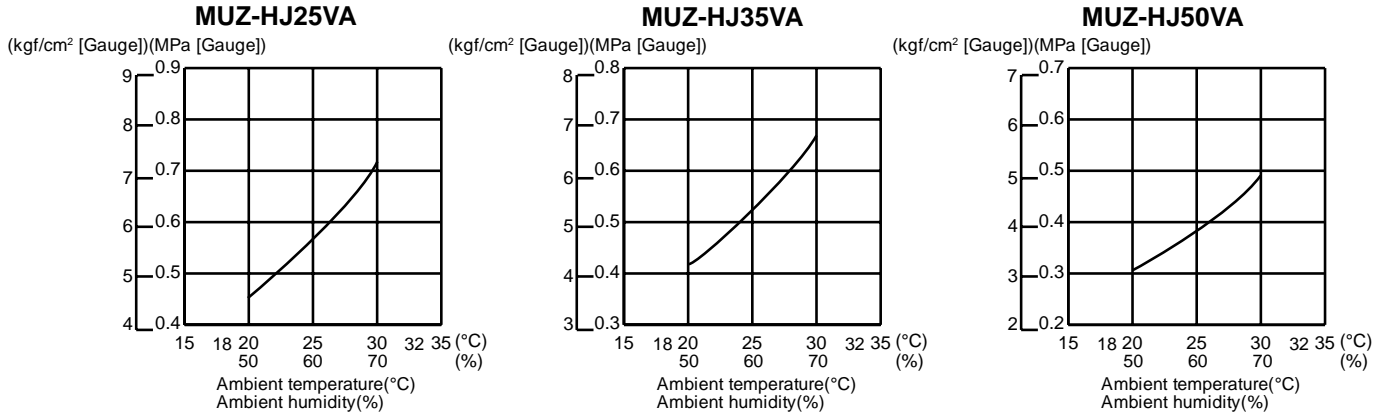

**NOTE :** The unit of pressure has been changed to MPa on the international system of units (SI unit system).  
The conversion factor is: **1 (MPa [Gauge]) = 10.2 (kgf/cm²[Gauge])**

### Outdoor unit current

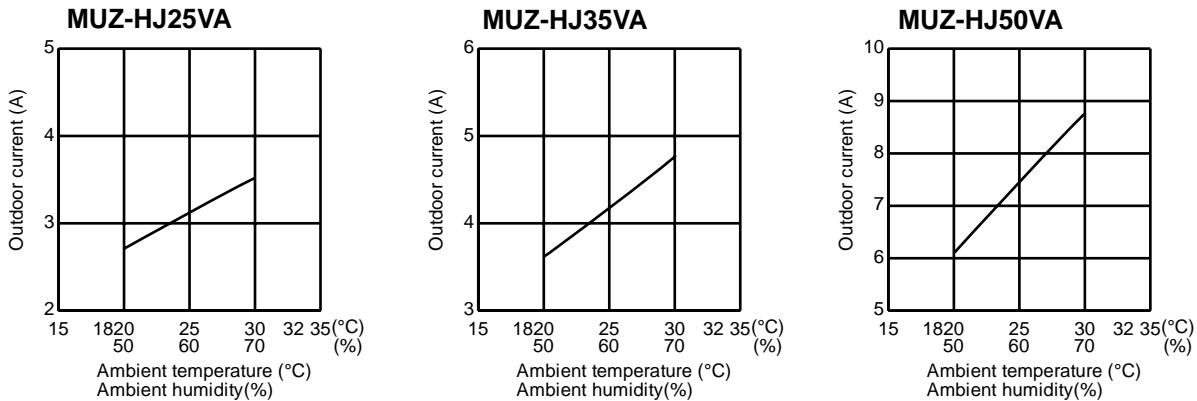

### HEAT operation

① Condition:

	Indoor	Outdoor			
Dry bulb temperature (°C)	20.0	2	7	15	20.0
Wet bulb temperature (°C)	14.5	1	6	12	14.5

- ② Operation: Test run operation (refer to 8-3.)

### Outdoor unit current

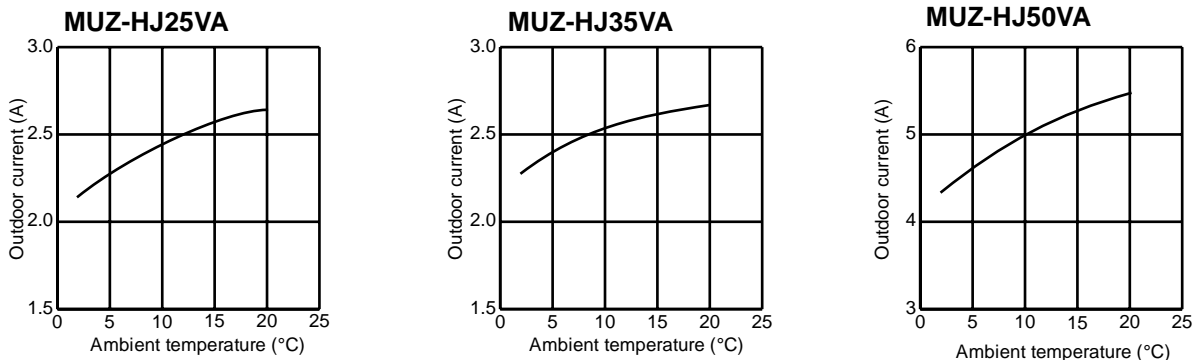



**PERFORMANCE DATA COOL operation at Rated frequency**

**MUZ-HJ25VA**

CAPACITY: 2.5 kW

SHF: 0.89

INPUT: 730 W

INDOOR DB (°C)	INDOOR WB (°C)	OUTDOOR DB (°C)															
		21				25				27				30			
		Q	SHC	SHF	INPUT	Q	SHC	SHF	INPUT	Q	SHC	SHF	INPUT	Q	SHC	SHF	INPUT
21	18	2.94	2.09	0.71	584	2.81	2.00	0.71	613	2.70	1.92	0.71	642	2.60	1.85	0.71	672
21	20	3.06	1.81	0.59	613	2.94	1.73	0.59	650	2.85	1.68	0.59	664	2.75	1.62	0.59	694
22	18	2.94	2.20	0.75	584	2.81	2.11	0.75	613	2.70	2.03	0.75	642	2.60	1.95	0.75	672
22	20	3.06	1.93	0.63	613	2.94	1.85	0.63	650	2.85	1.80	0.63	664	2.75	1.73	0.63	694
22	22	3.19	1.63	0.51	635	3.08	1.57	0.51	675	3.00	1.53	0.51	694	2.88	1.47	0.51	723
23	18	2.94	2.32	0.79	584	2.81	2.22	0.79	613	2.70	2.13	0.79	642	2.60	2.05	0.79	672
23	20	3.06	2.05	0.67	613	2.94	1.97	0.67	650	2.85	1.91	0.67	664	2.75	1.84	0.67	694
23	22	3.19	1.75	0.55	635	3.08	1.69	0.55	675	3.00	1.65	0.55	694	2.88	1.58	0.55	723
24	18	2.94	2.44	0.83	584	2.81	2.33	0.83	613	2.70	2.24	0.83	642	2.60	2.16	0.83	672
24	20	3.06	2.17	0.71	613	2.94	2.09	0.71	650	2.85	2.02	0.71	664	2.75	1.95	0.71	694
24	22	3.19	1.88	0.59	635	3.08	1.81	0.59	675	3.00	1.77	0.59	694	2.88	1.70	0.59	723
24	24	3.35	1.57	0.47	664	3.23	1.52	0.47	701	3.15	1.48	0.47	723	3.05	1.43	0.47	759
25	18	2.94	2.56	0.87	584	2.81	2.45	0.87	613	2.70	2.35	0.87	642	2.60	2.26	0.87	672
25	20	3.06	2.30	0.75	613	2.94	2.20	0.75	650	2.85	2.14	0.75	664	2.75	2.06	0.75	694
25	22	3.19	2.01	0.63	635	3.08	1.94	0.63	675	3.00	1.89	0.63	694	2.88	1.81	0.63	723
25	24	3.35	1.71	0.51	664	3.23	1.64	0.51	701	3.15	1.61	0.51	723	3.05	1.56	0.51	759
26	18	2.94	2.67	0.91	584	2.81	2.56	0.91	613	2.70	2.46	0.91	642	2.60	2.37	0.91	672
26	20	3.06	2.42	0.79	613	2.94	2.32	0.79	650	2.85	2.25	0.79	664	2.75	2.17	0.79	694
26	22	3.19	2.14	0.67	635	3.08	2.06	0.67	675	3.00	2.01	0.67	694	2.88	1.93	0.67	723
26	24	3.35	1.84	0.55	664	3.23	1.77	0.55	701	3.15	1.73	0.55	723	3.05	1.68	0.55	759
26	26	3.45	1.48	0.43	701	3.35	1.44	0.43	737	3.30	1.42	0.43	759	3.20	1.38	0.43	781
27	18	2.94	2.79	0.95	584	2.81	2.67	0.95	613	2.70	2.57	0.95	642	2.60	2.47	0.95	672
27	20	3.06	2.54	0.83	613	2.94	2.44	0.83	650	2.85	2.37	0.83	664	2.75	2.28	0.83	694
27	22	3.19	2.26	0.71	635	3.08	2.18	0.71	675	3.00	2.13	0.71	694	2.88	2.04	0.71	723
27	24	3.35	1.98	0.59	664	3.23	1.90	0.59	701	3.15	1.86	0.59	723	3.05	1.80	0.59	759
27	26	3.45	1.62	0.47	701	3.35	1.57	0.47	737	3.30	1.55	0.47	759	3.20	1.50	0.47	781
28	18	2.94	2.91	0.99	584	2.81	2.78	0.99	613	2.70	2.67	0.99	642	2.60	2.57	0.99	672
28	20	3.06	2.66	0.87	613	2.94	2.56	0.87	650	2.85	2.48	0.87	664	2.75	2.39	0.87	694
28	22	3.19	2.39	0.75	635	3.08	2.31	0.75	675	3.00	2.25	0.75	694	2.88	2.16	0.75	723
28	24	3.35	2.11	0.63	664	3.23	2.03	0.63	701	3.15	1.98	0.63	723	3.05	1.92	0.63	759
28	26	3.45	1.76	0.51	701	3.35	1.71	0.51	737	3.30	1.68	0.51	759	3.20	1.63	0.51	781
29	18	2.94	2.94	1.00	584	2.81	2.81	1.00	613	2.70	2.70	1.00	642	2.60	2.60	1.00	672
29	20	3.06	2.79	0.91	613	2.94	2.67	0.91	650	2.85	2.59	0.91	664	2.75	2.50	0.91	694
29	22	3.19	2.52	0.79	635	3.08	2.43	0.79	675	3.00	2.37	0.79	694	2.88	2.27	0.79	723
29	24	3.35	2.24	0.67	664	3.23	2.16	0.67	701	3.15	2.11	0.67	723	3.05	2.04	0.67	759
29	26	3.45	1.90	0.55	701	3.35	1.84	0.55	737	3.30	1.82	0.55	759	3.20	1.76	0.55	781
30	18	2.94	2.94	1.00	584	2.81	2.81	1.00	613	2.70	2.70	1.00	642	2.60	2.60	1.00	672
30	20	3.06	2.91	0.95	613	2.94	2.79	0.95	650	2.85	2.71	0.95	664	2.75	2.61	0.95	694
30	22	3.19	2.65	0.83	635	3.08	2.55	0.83	675	3.00	2.49	0.83	694	2.88	2.39	0.83	723
30	24	3.35	2.38	0.71	664	3.23	2.29	0.71	701	3.15	2.24	0.71	723	3.05	2.17	0.71	759
30	26	3.45	2.04	0.59	701	3.35	1.98	0.59	737	3.30	1.95	0.59	759	3.20	1.89	0.59	781
31	18	2.94	2.94	1.00	584	2.81	2.81	1.00	613	2.70	2.70	1.00	642	2.60	2.60	1.00	672
31	20	3.06	3.03	0.99	613	2.94	2.91	0.99	650	2.85	2.82	0.99	664	2.75	2.72	0.99	694
31	22	3.19	2.77	0.87	635	3.08	2.68	0.87	675	3.00	2.61	0.87	694	2.88	2.50	0.87	723
31	24	3.35	2.51	0.75	664	3.23	2.42	0.75	701	3.15	2.36	0.75	723	3.05	2.29	0.75	759
31	26	3.45	2.17	0.63	701	3.35	2.11	0.63	737	3.30	2.08	0.63	759	3.20	2.02	0.63	781
32	18	2.94	2.94	1.00	584	2.81	2.81	1.00	613	2.70	2.70	1.00	642	2.60	2.60	1.00	672
32	20	3.06	3.06	1.00	613	2.94	2.94	1.00	650	2.85	2.85	1.00	664	2.75	2.75	1.00	694
32	22	3.19	2.90	0.91	635	3.08	2.80	0.91	675	3.00	2.73	0.91	694	2.88	2.62	0.91	723
32	24	3.35	2.65	0.79	664	3.23	2.55	0.79	701	3.15	2.49	0.79	723	3.05	2.41	0.79	759
32	26	3.45	2.31	0.67	701	3.35	2.24	0.67	737	3.30	2.21	0.67	759	3.20	2.14	0.67	781

**NOTE** Q : Total capacity (kW) SHF : Sensible heat factor DB : Dry-bulb temperature  
 SHC : Sensible heat capacity (kW) INPUT : Total power input (W) WB : Wet-bulb temperature

**PERFORMANCE DATA COOL operation at Rated frequency**

**MUZ-HJ25VA**

CAPACITY: 2.5 kW

SHF: 0.89

INPUT: 730 W

INDOOR DB (°C)	INDOOR WB (°C)	OUTDOOR DB (°C)											
		35				40				46			
		Q	SHC	SHF	INPUT	Q	SHC	SHF	INPUT	Q	SHC	SHF	INPUT
21	18	2.45	1.74	0.71	715	2.25	1.60	0.71	759	2.08	1.47	0.71	788
21	20	2.58	1.52	0.59	745	2.40	1.42	0.59	781	2.23	1.31	0.59	825
22	18	2.45	1.84	0.75	715	2.25	1.69	0.75	759	2.08	1.56	0.75	788
22	20	2.58	1.62	0.63	745	2.40	1.51	0.63	781	2.23	1.40	0.63	825
22	22	2.73	1.39	0.51	774	2.55	1.30	0.51	818	2.38	1.21	0.51	847
23	18	2.45	1.94	0.79	715	2.25	1.78	0.79	759	2.08	1.64	0.79	788
23	20	2.58	1.73	0.67	745	2.40	1.61	0.67	781	2.23	1.49	0.67	825
23	22	2.73	1.50	0.55	774	2.55	1.40	0.55	818	2.38	1.31	0.55	847
24	18	2.45	2.03	0.83	715	2.25	1.87	0.83	759	2.08	1.72	0.83	788
24	20	2.58	1.83	0.71	745	2.40	1.70	0.71	781	2.23	1.58	0.71	825
24	22	2.73	1.61	0.59	774	2.55	1.50	0.59	818	2.38	1.40	0.59	847
24	24	2.88	1.35	0.47	803	2.70	1.27	0.47	839	2.55	1.20	0.47	876
25	18	2.45	2.13	0.87	715	2.25	1.96	0.87	759	2.08	1.81	0.87	788
25	20	2.58	1.93	0.75	745	2.40	1.80	0.75	781	2.23	1.67	0.75	825
25	22	2.73	1.72	0.63	774	2.55	1.61	0.63	818	2.38	1.50	0.63	847
25	24	2.88	1.47	0.51	803	2.70	1.38	0.51	839	2.55	1.30	0.51	876
26	18	2.45	2.23	0.91	715	2.25	2.05	0.91	759	2.08	1.89	0.91	788
26	20	2.58	2.03	0.79	745	2.40	1.90	0.79	781	2.23	1.76	0.79	825
26	22	2.73	1.83	0.67	774	2.55	1.71	0.67	818	2.38	1.59	0.67	847
26	24	2.88	1.58	0.55	803	2.70	1.49	0.55	839	2.55	1.40	0.55	876
26	26	3.03	1.30	0.43	832	2.85	1.23	0.43	869	2.68	1.15	0.43	905
27	18	2.45	2.33	0.95	715	2.25	2.14	0.95	759	2.08	1.97	0.95	788
27	20	2.58	2.14	0.83	745	2.40	1.99	0.83	781	2.23	1.85	0.83	825
27	22	2.73	1.93	0.71	774	2.55	1.81	0.71	818	2.38	1.69	0.71	847
27	24	2.88	1.70	0.59	803	2.70	1.59	0.59	839	2.55	1.50	0.59	876
27	26	3.03	1.42	0.47	832	2.85	1.34	0.47	869	2.68	1.26	0.47	905
28	18	2.45	2.43	0.99	715	2.25	2.23	0.99	759	2.08	2.05	0.99	788
28	20	2.58	2.24	0.87	745	2.40	2.09	0.87	781	2.23	1.94	0.87	825
28	22	2.73	2.04	0.75	774	2.55	1.91	0.75	818	2.38	1.78	0.75	847
28	24	2.88	1.81	0.63	803	2.70	1.70	0.63	839	2.55	1.61	0.63	876
28	26	3.03	1.54	0.51	832	2.85	1.45	0.51	869	2.68	1.36	0.51	905
29	18	2.45	2.45	1.00	715	2.25	2.25	1.00	759	2.08	2.08	1.00	788
29	20	2.58	2.34	0.91	745	2.40	2.18	0.91	781	2.23	2.02	0.91	825
29	22	2.73	2.15	0.79	774	2.55	2.01	0.79	818	2.38	1.88	0.79	847
29	24	2.88	1.93	0.67	803	2.70	1.81	0.67	839	2.55	1.71	0.67	876
29	26	3.03	1.66	0.55	832	2.85	1.57	0.55	869	2.68	1.47	0.55	905
30	18	2.45	2.45	1.00	715	2.25	2.25	1.00	759	2.08	2.08	1.00	788
30	20	2.58	2.45	0.95	745	2.40	2.28	0.95	781	2.23	2.11	0.95	825
30	22	2.73	2.26	0.83	774	2.55	2.12	0.83	818	2.38	1.97	0.83	847
30	24	2.88	2.04	0.71	803	2.70	1.92	0.71	839	2.55	1.81	0.71	876
30	26	3.03	1.78	0.59	832	2.85	1.68	0.59	869	2.68	1.58	0.59	905
31	18	2.45	2.45	1.00	715	2.25	2.25	1.00	759	2.08	2.08	1.00	788
31	20	2.58	2.55	0.99	745	2.40	2.38	0.99	781	2.23	2.20	0.99	825
31	22	2.73	2.37	0.87	774	2.55	2.22	0.87	818	2.38	2.07	0.87	847
31	24	2.88	2.16	0.75	803	2.70	2.03	0.75	839	2.55	1.91	0.75	876
31	26	3.03	1.91	0.63	832	2.85	1.80	0.63	869	2.68	1.69	0.63	905
32	18	2.45	2.45	1.00	715	2.25	2.25	1.00	759	2.08	2.08	1.00	788
32	20	2.58	2.58	1.00	745	2.40	2.40	1.00	781	2.23	2.23	1.00	825
32	22	2.73	2.48	0.91	774	2.55	2.32	0.91	818	2.38	2.16	0.91	847
32	24	2.88	2.27	0.79	803	2.70	2.13	0.79	839	2.55	2.01	0.79	876
32	26	3.03	2.03	0.67	832	2.85	1.91	0.67	869	2.68	1.79	0.67	905

**NOTE** Q : Total capacity (kW) SHF : Sensible heat factor DB : Dry-bulb temperature  
 SHC : Sensible heat capacity (kW) INPUT : Total power input (W) WB : Wet-bulb temperature

**PERFORMANCE DATA COOL operation at Rated frequency**

**MUZ-HJ35VA**

CAPACITY: 3.15 kW

SHF: 0.87

INPUT: 1040 W

INDOOR DB (°C)	INDOOR WB (°C)	OUTDOOR DB (°C)															
		21				25				27				30			
		Q	SHC	SHF	INPUT	Q	SHC	SHF	INPUT	Q	SHC	SHF	INPUT	Q	SHC	SHF	INPUT
21	18	3.70	2.55	0.69	832	3.54	2.45	0.69	874	3.40	2.35	0.69	915	3.28	2.26	0.69	957
21	20	3.86	2.20	0.57	874	3.70	2.11	0.57	926	3.59	2.05	0.57	946	3.47	1.98	0.57	988
22	18	3.70	2.70	0.73	832	3.54	2.59	0.73	874	3.40	2.48	0.73	915	3.28	2.39	0.73	957
22	20	3.86	2.35	0.61	874	3.70	2.26	0.61	926	3.59	2.19	0.61	946	3.47	2.11	0.61	988
22	22	4.02	1.97	0.49	905	3.87	1.90	0.49	962	3.78	1.85	0.49	988	3.62	1.78	0.49	1030
23	18	3.70	2.85	0.77	832	3.54	2.73	0.77	874	3.40	2.62	0.77	915	3.28	2.52	0.77	957
23	20	3.86	2.51	0.65	874	3.70	2.41	0.65	926	3.59	2.33	0.65	946	3.47	2.25	0.65	988
23	22	4.02	2.13	0.53	905	3.87	2.05	0.53	962	3.78	2.00	0.53	988	3.62	1.92	0.53	1030
24	18	3.70	3.00	0.81	832	3.54	2.87	0.81	874	3.40	2.76	0.81	915	3.28	2.65	0.81	957
24	20	3.86	2.66	0.69	874	3.70	2.55	0.69	926	3.59	2.48	0.69	946	3.47	2.39	0.69	988
24	22	4.02	2.29	0.57	905	3.87	2.21	0.57	962	3.78	2.15	0.57	988	3.62	2.06	0.57	1030
24	24	4.22	1.90	0.45	946	4.06	1.83	0.45	998	3.97	1.79	0.45	1030	3.84	1.73	0.45	1082
25	18	3.70	3.15	0.85	832	3.54	3.01	0.85	874	3.40	2.89	0.85	915	3.28	2.78	0.85	957
25	20	3.86	2.82	0.73	874	3.70	2.70	0.73	926	3.59	2.62	0.73	946	3.47	2.53	0.73	988
25	22	4.02	2.45	0.61	905	3.87	2.36	0.61	962	3.78	2.31	0.61	988	3.62	2.21	0.61	1030
25	24	4.22	2.07	0.49	946	4.06	1.99	0.49	998	3.97	1.94	0.49	1030	3.84	1.88	0.49	1082
26	18	3.70	3.29	0.89	832	3.54	3.15	0.89	874	3.40	3.03	0.89	915	3.28	2.92	0.89	957
26	20	3.86	2.97	0.77	874	3.70	2.85	0.77	926	3.59	2.77	0.77	946	3.47	2.67	0.77	988
26	22	4.02	2.61	0.65	905	3.87	2.52	0.65	962	3.78	2.46	0.65	988	3.62	2.35	0.65	1030
26	24	4.22	2.24	0.53	946	4.06	2.15	0.53	998	3.97	2.10	0.53	1030	3.84	2.04	0.53	1082
26	26	4.35	1.78	0.41	998	4.22	1.73	0.41	1050	4.16	1.70	0.41	1082	4.03	1.65	0.41	1113
27	18	3.70	3.44	0.93	832	3.54	3.30	0.93	874	3.40	3.16	0.93	915	3.28	3.05	0.93	957
27	20	3.86	3.13	0.81	874	3.70	3.00	0.81	926	3.59	2.91	0.81	946	3.47	2.81	0.81	988
27	22	4.02	2.77	0.69	905	3.87	2.67	0.69	962	3.78	2.61	0.69	988	3.62	2.50	0.69	1030
27	24	4.22	2.41	0.57	946	4.06	2.32	0.57	998	3.97	2.26	0.57	1030	3.84	2.19	0.57	1082
27	26	4.35	1.96	0.45	998	4.22	1.90	0.45	1050	4.16	1.87	0.45	1082	4.03	1.81	0.45	1113
28	18	3.70	3.59	0.97	832	3.54	3.44	0.97	874	3.40	3.30	0.97	915	3.28	3.18	0.97	957
28	20	3.86	3.28	0.85	874	3.70	3.15	0.85	926	3.59	3.05	0.85	946	3.47	2.95	0.85	988
28	22	4.02	2.93	0.73	905	3.87	2.83	0.73	962	3.78	2.76	0.73	988	3.62	2.64	0.73	1030
28	24	4.22	2.57	0.61	946	4.06	2.48	0.61	998	3.97	2.42	0.61	1030	3.84	2.34	0.61	1082
28	26	4.35	2.13	0.49	998	4.22	2.07	0.49	1050	4.16	2.04	0.49	1082	4.03	1.98	0.49	1113
29	18	3.70	3.70	1.00	832	3.54	3.54	1.00	874	3.40	3.40	1.00	915	3.28	3.28	1.00	957
29	20	3.86	3.43	0.89	874	3.70	3.29	0.89	926	3.59	3.20	0.89	946	3.47	3.08	0.89	988
29	22	4.02	3.09	0.77	905	3.87	2.98	0.77	962	3.78	2.91	0.77	988	3.62	2.79	0.77	1030
29	24	4.22	2.74	0.65	946	4.06	2.64	0.65	998	3.97	2.58	0.65	1030	3.84	2.50	0.65	1082
29	26	4.35	2.30	0.53	998	4.22	2.24	0.53	1050	4.16	2.20	0.53	1082	4.03	2.14	0.53	1113
30	18	3.70	3.70	1.00	832	3.54	3.54	1.00	874	3.40	3.40	1.00	915	3.28	3.28	1.00	957
30	20	3.86	3.59	0.93	874	3.70	3.44	0.93	926	3.59	3.34	0.93	946	3.47	3.22	0.93	988
30	22	4.02	3.25	0.81	905	3.87	3.14	0.81	962	3.78	3.06	0.81	988	3.62	2.93	0.81	1030
30	24	4.22	2.91	0.69	946	4.06	2.80	0.69	998	3.97	2.74	0.69	1030	3.84	2.65	0.69	1082
30	26	4.35	2.48	0.57	998	4.22	2.41	0.57	1050	4.16	2.37	0.57	1082	4.03	2.30	0.57	1113
31	18	3.70	3.70	1.00	832	3.54	3.54	1.00	874	3.40	3.40	1.00	915	3.28	3.28	1.00	957
31	20	3.86	3.74	0.97	874	3.70	3.59	0.97	926	3.59	3.48	0.97	946	3.47	3.36	0.97	988
31	22	4.02	3.41	0.85	905	3.87	3.29	0.85	962	3.78	3.21	0.85	988	3.62	3.08	0.85	1030
31	24	4.22	3.08	0.73	946	4.06	2.97	0.73	998	3.97	2.90	0.73	1030	3.84	2.81	0.73	1082
31	26	4.35	2.65	0.61	998	4.22	2.57	0.61	1050	4.16	2.54	0.61	1082	4.03	2.46	0.61	1113
32	18	3.70	3.70	1.00	832	3.54	3.54	1.00	874	3.40	3.40	1.00	915	3.28	3.28	1.00	957
32	20	3.86	3.86	1.00	874	3.70	3.70	1.00	926	3.59	3.59	1.00	946	3.47	3.47	1.00	988
32	22	4.02	3.57	0.89	905	3.87	3.45	0.89	962	3.78	3.36	0.89	988	3.62	3.22	0.89	1030
32	24	4.22	3.25	0.77	946	4.06	3.13	0.77	998	3.97	3.06	0.77	1030	3.84	2.96	0.77	1082
32	26	4.35	2.83	0.65	998	4.22	2.74	0.65	1050	4.16	2.70	0.65	1082	4.03	2.62	0.65	1113

**NOTE** Q : Total capacity (kW) SHF : Sensible heat factor DB : Dry-bulb temperature  
 SHC : Sensible heat capacity (kW) INPUT : Total power input (W) WB : Wet-bulb temperature

**PERFORMANCE DATA COOL operation at Rated frequency**

**MUZ-HJ35VA**

CAPACITY: 3.15 kW

SHF: 0.87

INPUT: 1040 W

INDOOR DB (°C)	INDOOR WB (°C)	OUTDOOR DB (°C)											
		35				40				46			
		Q	SHC	SHF	INPUT	Q	SHC	SHF	INPUT	Q	SHC	SHF	INPUT
21	18	3.09	2.13	0.69	1019	2.84	1.96	0.69	1082	2.61	1.80	0.69	1123
21	20	3.24	1.85	0.57	1061	3.02	1.72	0.57	1113	2.80	1.60	0.57	1175
22	18	3.09	2.25	0.73	1019	2.84	2.07	0.73	1082	2.61	1.91	0.73	1123
22	20	3.24	1.98	0.61	1061	3.02	1.84	0.61	1113	2.80	1.71	0.61	1175
22	22	3.43	1.68	0.49	1102	3.21	1.57	0.49	1165	2.99	1.47	0.49	1206
23	18	3.09	2.38	0.77	1019	2.84	2.18	0.77	1082	2.61	2.01	0.77	1123
23	20	3.24	2.11	0.65	1061	3.02	1.97	0.65	1113	2.80	1.82	0.65	1175
23	22	3.43	1.82	0.53	1102	3.21	1.70	0.53	1165	2.99	1.59	0.53	1206
24	18	3.09	2.50	0.81	1019	2.84	2.30	0.81	1082	2.61	2.12	0.81	1123
24	20	3.24	2.24	0.69	1061	3.02	2.09	0.69	1113	2.80	1.93	0.69	1175
24	22	3.43	1.96	0.57	1102	3.21	1.83	0.57	1165	2.99	1.71	0.57	1206
24	24	3.62	1.63	0.45	1144	3.40	1.53	0.45	1196	3.21	1.45	0.45	1248
25	18	3.09	2.62	0.85	1019	2.84	2.41	0.85	1082	2.61	2.22	0.85	1123
25	20	3.24	2.37	0.73	1061	3.02	2.21	0.73	1113	2.80	2.05	0.73	1175
25	22	3.43	2.09	0.61	1102	3.21	1.96	0.61	1165	2.99	1.83	0.61	1206
25	24	3.62	1.78	0.49	1144	3.40	1.67	0.49	1196	3.21	1.57	0.49	1248
26	18	3.09	2.75	0.89	1019	2.84	2.52	0.89	1082	2.61	2.33	0.89	1123
26	20	3.24	2.50	0.77	1061	3.02	2.33	0.77	1113	2.80	2.16	0.77	1175
26	22	3.43	2.23	0.65	1102	3.21	2.09	0.65	1165	2.99	1.95	0.65	1206
26	24	3.62	1.92	0.53	1144	3.40	1.80	0.53	1196	3.21	1.70	0.53	1248
26	26	3.81	1.56	0.41	1186	3.59	1.47	0.41	1238	3.37	1.38	0.41	1290
27	18	3.09	2.87	0.93	1019	2.84	2.64	0.93	1082	2.61	2.43	0.93	1123
27	20	3.24	2.63	0.81	1061	3.02	2.45	0.81	1113	2.80	2.27	0.81	1175
27	22	3.43	2.37	0.69	1102	3.21	2.22	0.69	1165	2.99	2.06	0.69	1206
27	24	3.62	2.06	0.57	1144	3.40	1.94	0.57	1196	3.21	1.83	0.57	1248
27	26	3.81	1.72	0.45	1186	3.59	1.62	0.45	1238	3.37	1.52	0.45	1290
28	18	3.09	2.99	0.97	1019	2.84	2.75	0.97	1082	2.61	2.54	0.97	1123
28	20	3.24	2.76	0.85	1061	3.02	2.57	0.85	1113	2.80	2.38	0.85	1175
28	22	3.43	2.51	0.73	1102	3.21	2.35	0.73	1165	2.99	2.18	0.73	1206
28	24	3.62	2.21	0.61	1144	3.40	2.08	0.61	1196	3.21	1.96	0.61	1248
28	26	3.81	1.87	0.49	1186	3.59	1.76	0.49	1238	3.37	1.65	0.49	1290
29	18	3.09	3.09	1.00	1019	2.84	2.84	1.00	1082	2.61	2.61	1.00	1123
29	20	3.24	2.89	0.89	1061	3.02	2.69	0.89	1113	2.80	2.50	0.89	1175
29	22	3.43	2.64	0.77	1102	3.21	2.47	0.77	1165	2.99	2.30	0.77	1206
29	24	3.62	2.35	0.65	1144	3.40	2.21	0.65	1196	3.21	2.09	0.65	1248
29	26	3.81	2.02	0.53	1186	3.59	1.90	0.53	1238	3.37	1.79	0.53	1290
30	18	3.09	3.09	1.00	1019	2.84	2.84	1.00	1082	2.61	2.61	1.00	1123
30	20	3.24	3.02	0.93	1061	3.02	2.81	0.93	1113	2.80	2.61	0.93	1175
30	22	3.43	2.78	0.81	1102	3.21	2.60	0.81	1165	2.99	2.42	0.81	1206
30	24	3.62	2.50	0.69	1144	3.40	2.35	0.69	1196	3.21	2.22	0.69	1248
30	26	3.81	2.17	0.57	1186	3.59	2.05	0.57	1238	3.37	1.92	0.57	1290
31	18	3.09	3.09	1.00	1019	2.84	2.84	1.00	1082	2.61	2.61	1.00	1123
31	20	3.24	3.15	0.97	1061	3.02	2.93	0.97	1113	2.80	2.72	0.97	1175
31	22	3.43	2.92	0.85	1102	3.21	2.73	0.85	1165	2.99	2.54	0.85	1206
31	24	3.62	2.64	0.73	1144	3.40	2.48	0.73	1196	3.21	2.35	0.73	1248
31	26	3.81	2.33	0.61	1186	3.59	2.19	0.61	1238	3.37	2.06	0.61	1290
32	18	3.09	3.09	1.00	1019	2.84	2.84	1.00	1082	2.61	2.61	1.00	1123
32	20	3.24	3.24	1.00	1061	3.02	3.02	1.00	1113	2.80	2.80	1.00	1175
32	22	3.43	3.06	0.89	1102	3.21	2.86	0.89	1165	2.99	2.66	0.89	1206
32	24	3.62	2.79	0.77	1144	3.40	2.62	0.77	1196	3.21	2.47	0.77	1248
32	26	3.81	2.48	0.65	1186	3.59	2.33	0.65	1238	3.37	2.19	0.65	1290

**NOTE** Q : Total capacity (kW) SHF : Sensible heat factor DB : Dry-bulb temperature  
 SHC : Sensible heat capacity (kW) INPUT : Total power input (W) WB : Wet-bulb temperature

**PERFORMANCE DATA COOL operation at Rated frequency  
MUZ-HJ50VA**

CAPACITY: 5.0 kW SHF: 0.70 INPUT: 2050 W

INDOOR DB (°C)	INDOOR WB (°C)	OUTDOOR DB (°C)															
		21				25				27				30			
		Q	SHC	SHF	INPUT	Q	SHC	SHF	INPUT	Q	SHC	SHF	INPUT	Q	SHC	SHF	INPUT
21	18	5.88	3.06	0.52	1640	5.63	2.93	0.52	1722	5.40	2.81	0.52	1804	5.20	2.70	0.52	1886
21	20	6.13	2.45	0.40	1722	5.88	2.35	0.40	1825	5.70	2.28	0.40	1866	5.50	2.20	0.40	1948
22	18	5.88	3.29	0.56	1640	5.63	3.15	0.56	1722	5.40	3.02	0.56	1804	5.20	2.91	0.56	1886
22	20	6.13	2.70	0.44	1722	5.88	2.59	0.44	1825	5.70	2.51	0.44	1866	5.50	2.42	0.44	1948
22	22	6.38	2.04	0.32	1784	6.15	1.97	0.32	1896	6.00	1.92	0.32	1948	5.75	1.84	0.32	2030
23	18	5.88	3.53	0.60	1640	5.63	3.38	0.60	1722	5.40	3.24	0.60	1804	5.20	3.12	0.60	1886
23	20	6.13	2.94	0.48	1722	5.88	2.82	0.48	1825	5.70	2.74	0.48	1866	5.50	2.64	0.48	1948
23	22	6.38	2.30	0.36	1784	6.15	2.21	0.36	1896	6.00	2.16	0.36	1948	5.75	2.07	0.36	2030
24	18	5.88	3.76	0.64	1640	5.63	3.60	0.64	1722	5.40	3.46	0.64	1804	5.20	3.33	0.64	1886
24	20	6.13	3.19	0.52	1722	5.88	3.06	0.52	1825	5.70	2.96	0.52	1866	5.50	2.86	0.52	1948
24	22	6.38	2.55	0.40	1784	6.15	2.46	0.40	1896	6.00	2.40	0.40	1948	5.75	2.30	0.40	2030
24	24	6.70	1.88	0.28	1866	6.45	1.81	0.28	1968	6.30	1.76	0.28	2030	6.10	1.71	0.28	2132
25	18	5.88	4.00	0.68	1640	5.63	3.83	0.68	1722	5.40	3.67	0.68	1804	5.20	3.54	0.68	1886
25	20	6.13	3.43	0.56	1722	5.88	3.29	0.56	1825	5.70	3.19	0.56	1866	5.50	3.08	0.56	1948
25	22	6.38	2.81	0.44	1784	6.15	2.71	0.44	1896	6.00	2.64	0.44	1948	5.75	2.53	0.44	2030
25	24	6.70	2.14	0.32	1866	6.45	2.06	0.32	1968	6.30	2.02	0.32	2030	6.10	1.95	0.32	2132
26	18	5.88	4.23	0.72	1640	5.63	4.05	0.72	1722	5.40	3.89	0.72	1804	5.20	3.74	0.72	1886
26	20	6.13	3.68	0.60	1722	5.88	3.53	0.60	1825	5.70	3.42	0.60	1866	5.50	3.30	0.60	1948
26	22	6.38	3.06	0.48	1784	6.15	2.95	0.48	1896	6.00	2.88	0.48	1948	5.75	2.76	0.48	2030
26	24	6.70	2.41	0.36	1866	6.45	2.32	0.36	1968	6.30	2.27	0.36	2030	6.10	2.20	0.36	2132
26	26	6.90	1.66	0.24	1968	6.70	1.61	0.24	2071	6.60	1.58	0.24	2132	6.40	1.54	0.24	2194
27	18	5.88	4.47	0.76	1640	5.63	4.28	0.76	1722	5.40	4.10	0.76	1804	5.20	3.95	0.76	1886
27	20	6.13	3.92	0.64	1722	5.88	3.76	0.64	1825	5.70	3.65	0.64	1866	5.50	3.52	0.64	1948
27	22	6.38	3.32	0.52	1784	6.15	3.20	0.52	1896	6.00	3.12	0.52	1948	5.75	2.99	0.52	2030
27	24	6.70	2.68	0.40	1866	6.45	2.58	0.40	1968	6.30	2.52	0.40	2030	6.10	2.44	0.40	2132
27	26	6.90	1.93	0.28	1968	6.70	1.88	0.28	2071	6.60	1.85	0.28	2132	6.40	1.79	0.28	2194
28	18	5.88	4.70	0.80	1640	5.63	4.50	0.80	1722	5.40	4.32	0.80	1804	5.20	4.16	0.80	1886
28	20	6.13	4.17	0.68	1722	5.88	4.00	0.68	1825	5.70	3.88	0.68	1866	5.50	3.74	0.68	1948
28	22	6.38	3.57	0.56	1784	6.15	3.44	0.56	1896	6.00	3.36	0.56	1948	5.75	3.22	0.56	2030
28	24	6.70	2.95	0.44	1866	6.45	2.84	0.44	1968	6.30	2.77	0.44	2030	6.10	2.68	0.44	2132
28	26	6.90	2.21	0.32	1968	6.70	2.14	0.32	2071	6.60	2.11	0.32	2132	6.40	2.05	0.32	2194
29	18	5.88	4.94	0.84	1640	5.63	4.73	0.84	1722	5.40	4.54	0.84	1804	5.20	4.37	0.84	1886
29	20	6.13	4.41	0.72	1722	5.88	4.23	0.72	1825	5.70	4.10	0.72	1866	5.50	3.96	0.72	1948
29	22	6.38	3.83	0.60	1784	6.15	3.69	0.60	1896	6.00	3.60	0.60	1948	5.75	3.45	0.60	2030
29	24	6.70	3.22	0.48	1866	6.45	3.10	0.48	1968	6.30	3.02	0.48	2030	6.10	2.93	0.48	2132
29	26	6.90	2.48	0.36	1968	6.70	2.41	0.36	2071	6.60	2.38	0.36	2132	6.40	2.30	0.36	2194
30	18	5.88	5.17	0.88	1640	5.63	4.95	0.88	1722	5.40	4.75	0.88	1804	5.20	4.58	0.88	1886
30	20	6.13	4.66	0.76	1722	5.88	4.47	0.76	1825	5.70	4.33	0.76	1866	5.50	4.18	0.76	1948
30	22	6.38	4.08	0.64	1784	6.15	3.94	0.64	1896	6.00	3.84	0.64	1948	5.75	3.68	0.64	2030
30	24	6.70	3.48	0.52	1866	6.45	3.35	0.52	1968	6.30	3.28	0.52	2030	6.10	3.17	0.52	2132
30	26	6.90	2.76	0.40	1968	6.70	2.68	0.40	2071	6.60	2.64	0.40	2132	6.40	2.56	0.40	2194
31	18	5.88	5.41	0.92	1640	5.63	5.18	0.92	1722	5.40	4.97	0.92	1804	5.20	4.78	0.92	1886
31	20	6.13	4.90	0.80	1722	5.88	4.70	0.80	1825	5.70	4.56	0.80	1866	5.50	4.40	0.80	1948
31	22	6.38	4.34	0.68	1784	6.15	4.18	0.68	1896	6.00	4.08	0.68	1948	5.75	3.91	0.68	2030
31	24	6.70	3.75	0.56	1866	6.45	3.61	0.56	1968	6.30	3.53	0.56	2030	6.10	3.42	0.56	2132
31	26	6.90	3.04	0.44	1968	6.70	2.95	0.44	2071	6.60	2.90	0.44	2132	6.40	2.82	0.44	2194
32	18	5.88	5.64	0.96	1640	5.63	5.40	0.96	1722	5.40	5.18	0.96	1804	5.20	4.99	0.96	1886
32	20	6.13	5.15	0.84	1722	5.88	4.94	0.84	1825	5.70	4.79	0.84	1866	5.50	4.62	0.84	1948
32	22	6.38	4.59	0.72	1784	6.15	4.43	0.72	1896	6.00	4.32	0.72	1948	5.75	4.14	0.72	2030
32	24	6.70	4.02	0.60	1866	6.45	3.87	0.60	1968	6.30	3.78	0.60	2030	6.10	3.66	0.60	2132
32	26	6.90	3.31	0.48	1968	6.70	3.22	0.48	2071	6.60	3.17	0.48	2132	6.40	3.07	0.48	2194

**NOTE** Q : Total capacity (kW) SHF : Sensible heat factor DB : Dry-bulb temperature  
SHC : Sensible heat capacity (kW) INPUT : Total power input (W) WB : Wet-bulb temperature

**PERFORMANCE DATA COOL operation at Rated frequency  
MUZ-HJ50VA**

CAPACITY: 5.0 kW

SHF: 0.70

INPUT: 2050 W

INDOOR DB (°C)	INDOOR WB (°C)	OUTDOOR DB (°C)											
		35				40				46			
		Q	SHC	SHF	INPUT	Q	SHC	SHF	INPUT	Q	SHC	SHF	INPUT
21	18	4.90	2.55	0.52	2009	4.50	2.34	0.52	2132	4.15	2.16	0.52	2214
21	20	5.15	2.06	0.40	2091	4.80	1.92	0.40	2194	4.45	1.78	0.40	2317
22	18	4.90	2.74	0.56	2009	4.50	2.52	0.56	2132	4.15	2.32	0.56	2214
22	20	5.15	2.27	0.44	2091	4.80	2.11	0.44	2194	4.45	1.96	0.44	2317
22	22	5.45	1.74	0.32	2173	5.10	1.63	0.32	2296	4.75	1.52	0.32	2378
23	18	4.90	2.94	0.60	2009	4.50	2.70	0.60	2132	4.15	2.49	0.60	2214
23	20	5.15	2.47	0.48	2091	4.80	2.30	0.48	2194	4.45	2.14	0.48	2317
23	22	5.45	1.96	0.36	2173	5.10	1.84	0.36	2296	4.75	1.71	0.36	2378
24	18	4.90	3.14	0.64	2009	4.50	2.88	0.64	2132	4.15	2.66	0.64	2214
24	20	5.15	2.68	0.52	2091	4.80	2.50	0.52	2194	4.45	2.31	0.52	2317
24	22	5.45	2.18	0.40	2173	5.10	2.04	0.40	2296	4.75	1.90	0.40	2378
24	24	5.75	1.61	0.28	2255	5.40	1.51	0.28	2358	5.10	1.43	0.28	2460
25	18	4.90	3.33	0.68	2009	4.50	3.06	0.68	2132	4.15	2.82	0.68	2214
25	20	5.15	2.88	0.56	2091	4.80	2.69	0.56	2194	4.45	2.49	0.56	2317
25	22	5.45	2.40	0.44	2173	5.10	2.24	0.44	2296	4.75	2.09	0.44	2378
25	24	5.75	1.84	0.32	2255	5.40	1.73	0.32	2358	5.10	1.63	0.32	2460
26	18	4.90	3.53	0.72	2009	4.50	3.24	0.72	2132	4.15	2.99	0.72	2214
26	20	5.15	3.09	0.60	2091	4.80	2.88	0.60	2194	4.45	2.67	0.60	2317
26	22	5.45	2.62	0.48	2173	5.10	2.45	0.48	2296	4.75	2.28	0.48	2378
26	24	5.75	2.07	0.36	2255	5.40	1.94	0.36	2358	5.10	1.84	0.36	2460
26	26	6.05	1.45	0.24	2337	5.70	1.37	0.24	2440	5.35	1.28	0.24	2542
27	18	4.90	3.72	0.76	2009	4.50	3.42	0.76	2132	4.15	3.15	0.76	2214
27	20	5.15	3.30	0.64	2091	4.80	3.07	0.64	2194	4.45	2.85	0.64	2317
27	22	5.45	2.83	0.52	2173	5.10	2.65	0.52	2296	4.75	2.47	0.52	2378
27	24	5.75	2.30	0.40	2255	5.40	2.16	0.40	2358	5.10	2.04	0.40	2460
27	26	6.05	1.69	0.28	2337	5.70	1.60	0.28	2440	5.35	1.50	0.28	2542
28	18	4.90	3.92	0.80	2009	4.50	3.60	0.80	2132	4.15	3.32	0.80	2214
28	20	5.15	3.50	0.68	2091	4.80	3.26	0.68	2194	4.45	3.03	0.68	2317
28	22	5.45	3.05	0.56	2173	5.10	2.86	0.56	2296	4.75	2.66	0.56	2378
28	24	5.75	2.53	0.44	2255	5.40	2.38	0.44	2358	5.10	2.24	0.44	2460
28	26	6.05	1.94	0.32	2337	5.70	1.82	0.32	2440	5.35	1.71	0.32	2542
29	18	4.90	4.12	0.84	2009	4.50	3.78	0.84	2132	4.15	3.49	0.84	2214
29	20	5.15	3.71	0.72	2091	4.80	3.46	0.72	2194	4.45	3.20	0.72	2317
29	22	5.45	3.27	0.60	2173	5.10	3.06	0.60	2296	4.75	2.85	0.60	2378
29	24	5.75	2.76	0.48	2255	5.40	2.59	0.48	2358	5.10	2.45	0.48	2460
29	26	6.05	2.18	0.36	2337	5.70	2.05	0.36	2440	5.35	1.93	0.36	2542
30	18	4.90	4.31	0.88	2009	4.50	3.96	0.88	2132	4.15	3.65	0.88	2214
30	20	5.15	3.91	0.76	2091	4.80	3.65	0.76	2194	4.45	3.38	0.76	2317
30	22	5.45	3.49	0.64	2173	5.10	3.26	0.64	2296	4.75	3.04	0.64	2378
30	24	5.75	2.99	0.52	2255	5.40	2.81	0.52	2358	5.10	2.65	0.52	2460
30	26	6.05	2.42	0.40	2337	5.70	2.28	0.40	2440	5.35	2.14	0.40	2542
31	18	4.90	4.51	0.92	2009	4.50	4.14	0.92	2132	4.15	3.82	0.92	2214
31	20	5.15	4.12	0.80	2091	4.80	3.84	0.80	2194	4.45	3.56	0.80	2317
31	22	5.45	3.71	0.68	2173	5.10	3.47	0.68	2296	4.75	3.23	0.68	2378
31	24	5.75	3.22	0.56	2255	5.40	3.02	0.56	2358	5.10	2.86	0.56	2460
31	26	6.05	2.66	0.44	2337	5.70	2.51	0.44	2440	5.35	2.35	0.44	2542
32	18	4.90	4.70	0.96	2009	4.50	4.32	0.96	2132	4.15	3.98	0.96	2214
32	20	5.15	4.33	0.84	2091	4.80	4.03	0.84	2194	4.45	3.74	0.84	2317
32	22	5.45	3.92	0.72	2173	5.10	3.67	0.72	2296	4.75	3.42	0.72	2378
32	24	5.75	3.45	0.60	2255	5.40	3.24	0.60	2358	5.10	3.06	0.60	2460
32	26	6.05	2.90	0.48	2337	5.70	2.74	0.48	2440	5.35	2.57	0.48	2542

**NOTE** Q : Total capacity (kW) SHF : Sensible heat factor DB : Dry-bulb temperature  
SHC : Sensible heat capacity (kW) INPUT : Total power input (W) WB : Wet-bulb temperature

**PERFORMANCE DATA HEAT operation at Rated frequency**  
**MUZ-HJ25VA**

CAPACITY: 3.15 kW INPUT: 870 W

INDOOR DB (°C)	OUTDOOR WB (°C)													
	-10		-5		0		5		10		15		20	
	Q	INPUT	Q	INPUT	Q	INPUT	Q	INPUT	Q	INPUT	Q	INPUT	Q	INPUT
15	1.98	566	2.39	679	2.80	766	3.21	827	3.62	879	4.00	905	4.41	922
21	1.89	609	2.27	722	2.68	800	3.06	861	3.47	905	3.84	931	4.24	966
26	1.70	653	2.11	766	2.49	844	2.90	905	3.31	948	3.69	974	4.10	1001

**MUZ-HJ35VA**

CAPACITY: 3.6 kW INPUT: 995 W

INDOOR DB (°C)	OUTDOOR WB (°C)													
	-10		-5		0		5		10		15		20	
	Q	INPUT	Q	INPUT	Q	INPUT	Q	INPUT	Q	INPUT	Q	INPUT	Q	INPUT
15	2.27	647	2.74	776	3.20	876	3.67	945	4.14	1005	4.57	1035	5.04	1055
21	2.16	697	2.59	826	3.06	915	3.49	985	3.96	1035	4.39	1065	4.84	1104
26	1.94	746	2.41	876	2.84	965	3.31	1035	3.78	1085	4.21	1114	4.68	1144

**MUZ-HJ50VA**

CAPACITY: 5.4 kW INPUT: 1480 W

INDOOR DB (°C)	OUTDOOR WB (°C)													
	-10		-5		0		5		10		15		20	
	Q	INPUT	Q	INPUT	Q	INPUT	Q	INPUT	Q	INPUT	Q	INPUT	Q	INPUT
15	3.40	962	4.10	1154	4.81	1302	5.51	1406	6.21	1495	6.86	1539	7.56	1569
21	3.24	1036	3.89	1228	4.59	1362	5.24	1465	5.94	1539	6.59	1584	7.26	1643
26	2.92	1110	3.62	1302	4.27	1436	4.97	1539	5.67	1613	6.32	1658	7.02	1702

**NOTE** Q: Total capacity (kW) INPUT : Total power input (W) DB: Dry-bulb temperature WB: Wet-bulb temperature

**MUZ-HJ25VA MUZ-HJ35VA MUZ-HJ50VA**

**9-1. OUTDOOR FAN MOTOR CONTROL**

The fan motor turns ON/OFF, interlocking with the compressor.

[ON] The fan motor turns ON 5 seconds before the compressor starts up.

[OFF] The fan motor turns OFF 15 seconds after the compressor has stopped running.

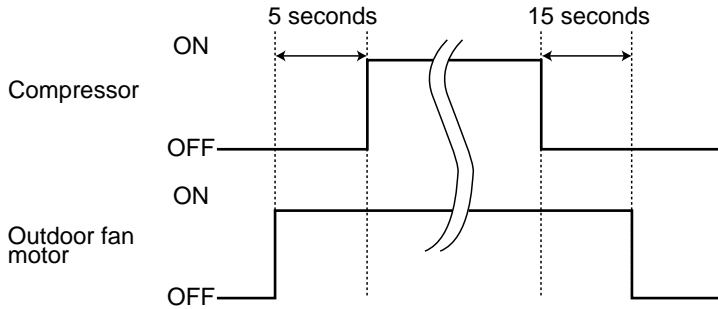

**9-2. R.V. COIL CONTROL**

**R.V. COIL CONTROL MUZ-HJ25VA MUZ-35VA**

Heating ..... OFF

Cooling ..... ON

Dry ..... ON

**NOTE:** The 4-way valve reverses for 5 seconds right before start-up of the compressor.

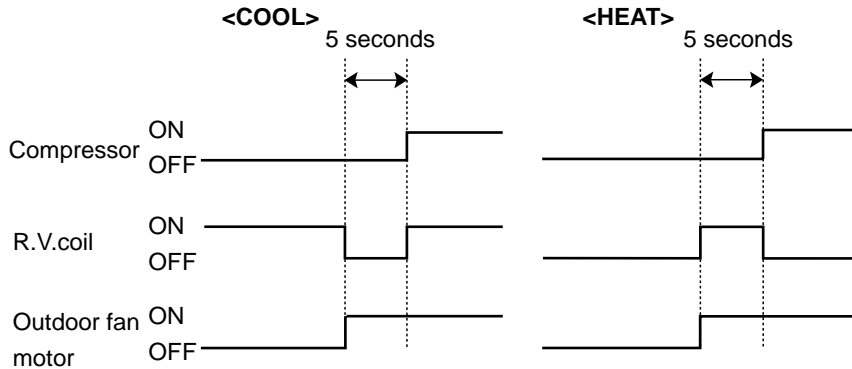

**R.V. COIL CONTROL MUZ-HJ50VA**

Heating ..... ON

Cooling ..... OFF

Dry ..... OFF

**NOTE:** The 4-way valve reverses for 5 seconds right before start-up of the compressor.

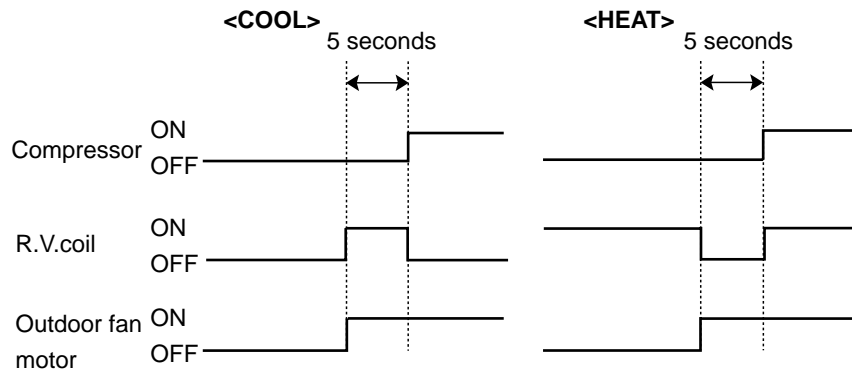

**9-3. RELATION BETWEEN MAIN SENSOR AND ACTUATOR**

Sensor	Purpose	Actuator				
		Compressor	LEV	Outdoor fan motor	R.V. coil	Indoor fan motor
Discharge temperature thermistor	Protection	○	○			
Indoor coil temperature thermistor	Cooling: Coil frost prevention	○				
	Heating: High pressure protection	○				
Defrost thermistor	Cooling: High pressure protection	○	○	○		
	Heating: Defrosting	○	○	○	○	○
Fin temperature thermistor	Protection	○		○		



# 10

## SERVICE FUNCTIONS

### MUZ-HJ25VA MUZ-HJ35VA MUZ-HJ50VA

#### 10-1. CHANGE IN DEFROST SETTING

<JS> When the JS wire of the inverter P.C. board is cut/ soldered, the defrost finish temperature is changed. (Refer to 11-6-1.)

Jumper wire		Defrost finish temperature (°C)	
		MUZ-HJ25/35VA	MUZ-HJ50VA
JS	Soldered (Initial setting)	8	
	None (Cut)	11	15

#### 10-2. PRE-HEAT CONTROL SETTING

##### PRE-HEAT CONTROL

When moisture gets into the refrigerant cycle, it may interfere the start-up of the compressor at low discharge temperature. The pre-heat control prevents this interference. The pre-heat control turns ON when the discharge temperature is 20°C or below. When the pre-heat control turns ON, the compressor is energized. (About 50 W)

<JK> When the JK wire of the inverter P.C. board is cut, pre-heat control is activated. (Refer to 11-6.1)

**NOTE :** When the inverter P.C. board is replaced, check the Jumper wires, and cut/solder them if necessary.

# 11

## TROUBLESHOOTING

### MUZ-HJ25VA MUZ-HJ35VA MUZ-HJ50VA

#### 11-1. CAUTIONS ON TROUBLESHOOTING

##### 1. Before troubleshooting, check the following:

- 1) Check the power supply voltage.
- 2) Check the indoor/outdoor connecting wire for miswiring.

##### 2. Take care of the following during servicing

- 1) Before servicing the air conditioner, be sure to turn OFF the main unit first with the remote controller, and then after confirming the horizontal vane is closed, turn OFF the breaker and/or disconnect the power plug.
- 2) Be sure to turn OFF the power supply before removing the front panel, the cabinet, the top panel, and the electronic control P.C. board.
- 3) When removing the electrical parts, be careful to the residual voltage of smoothing capacitor.
- 4) When removing the electronic control P.C. board, hold the edge of the board with care NOT to apply stress on the components.
- 5) When connecting or disconnecting the connectors, hold the housing of the connector. DO NOT pull the lead wires.

<Incorrect>

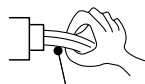

Lead wiring

<Correct>

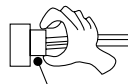

Housing point

##### 3. Troubleshooting procedure

- 1) Check if the OPERATION INDICATOR lamp on the indoor unit is flashing on and off to indicate an abnormality. To make sure, check how many times the OPERATION INDICATOR lamp is flashing on and off before starting service work.
- 2) Before servicing, check that the connector and terminal are connected properly.
- 3) When the electronic control P.C. board seems to be defective, check the copper foil pattern for disconnection and the components for bursting and discoloration.
- 4) Refer to 11-2 and 11-3.

## 11-2. FAILURE MODE RECALL FUNCTION

Outline of the function

This air conditioner can memorize the abnormal condition which has occurred once.

Even though LED indication listed on the troubleshooting check table (11-3.) disappears, the memorized failure details can be recalled.

This mode is very useful when the unit needs to be repaired for the abnormality which does not recur.

### 1. Flow chart of failure mode recall function for the indoor/outdoor unit

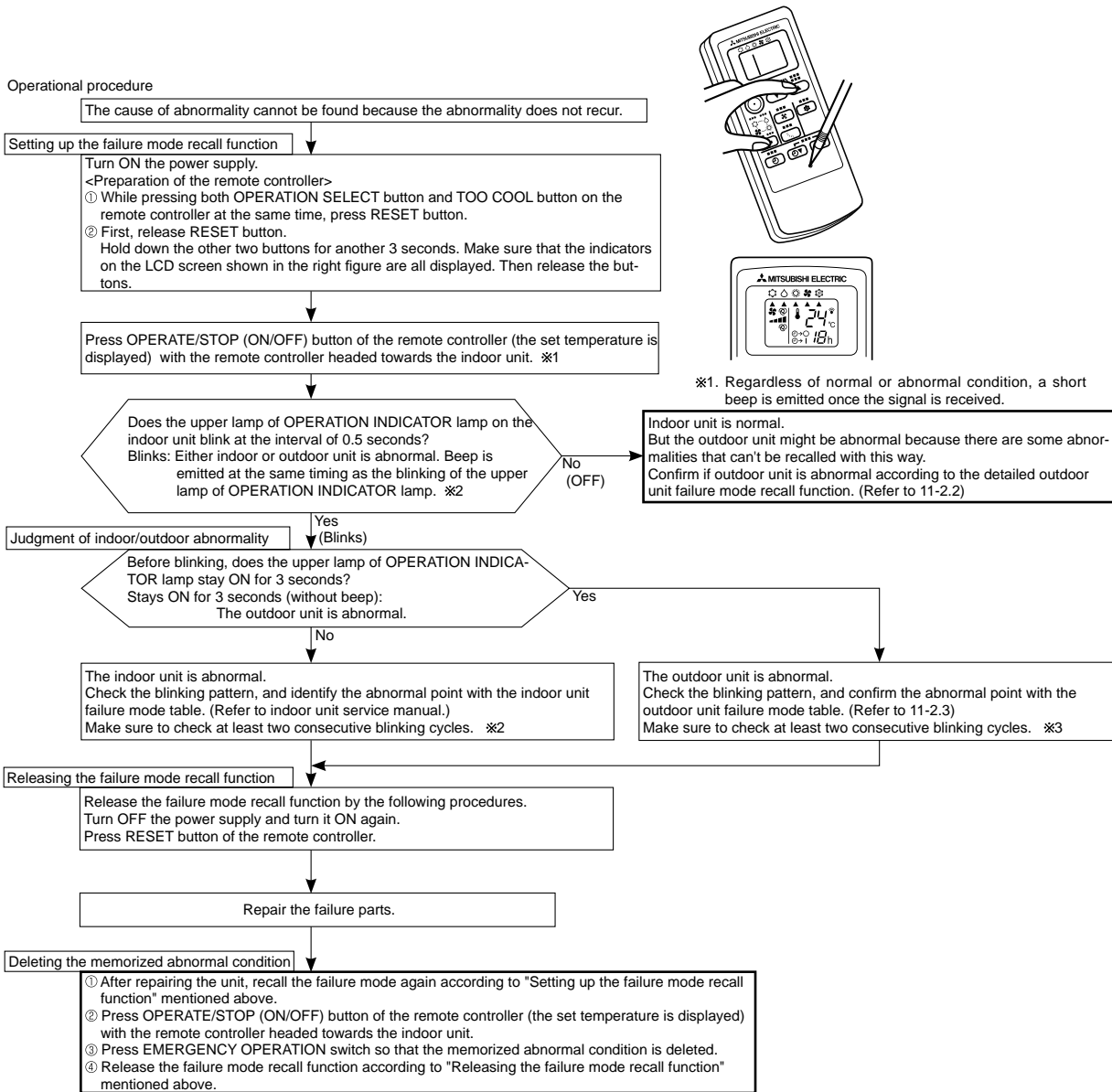

**NOTE:** 1. Make sure to release the failure mode recall function after it is set up, otherwise the unit cannot operate properly.  
 2. If the abnormal condition is not deleted from the memory, the last abnormal condition is kept memorized.

※2. Blinking pattern when the indoor unit is abnormal:

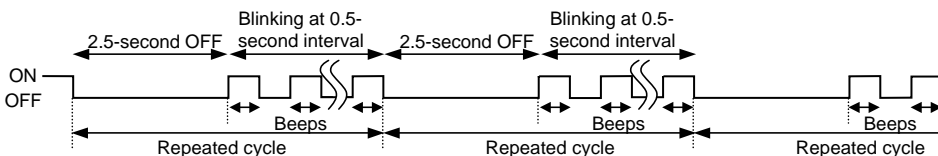

※3. Blinking pattern when the outdoor unit is abnormal:

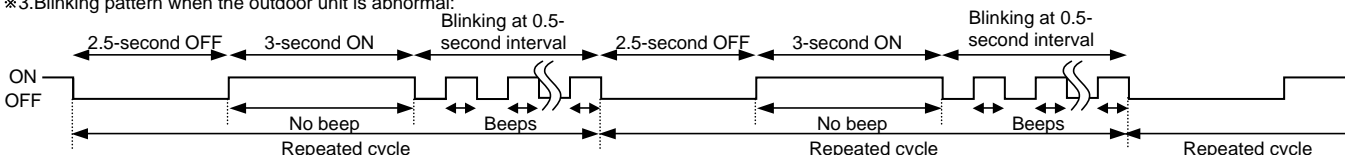

## 2. Flow chart of the detailed outdoor unit failure mode recall function

### Operational procedure

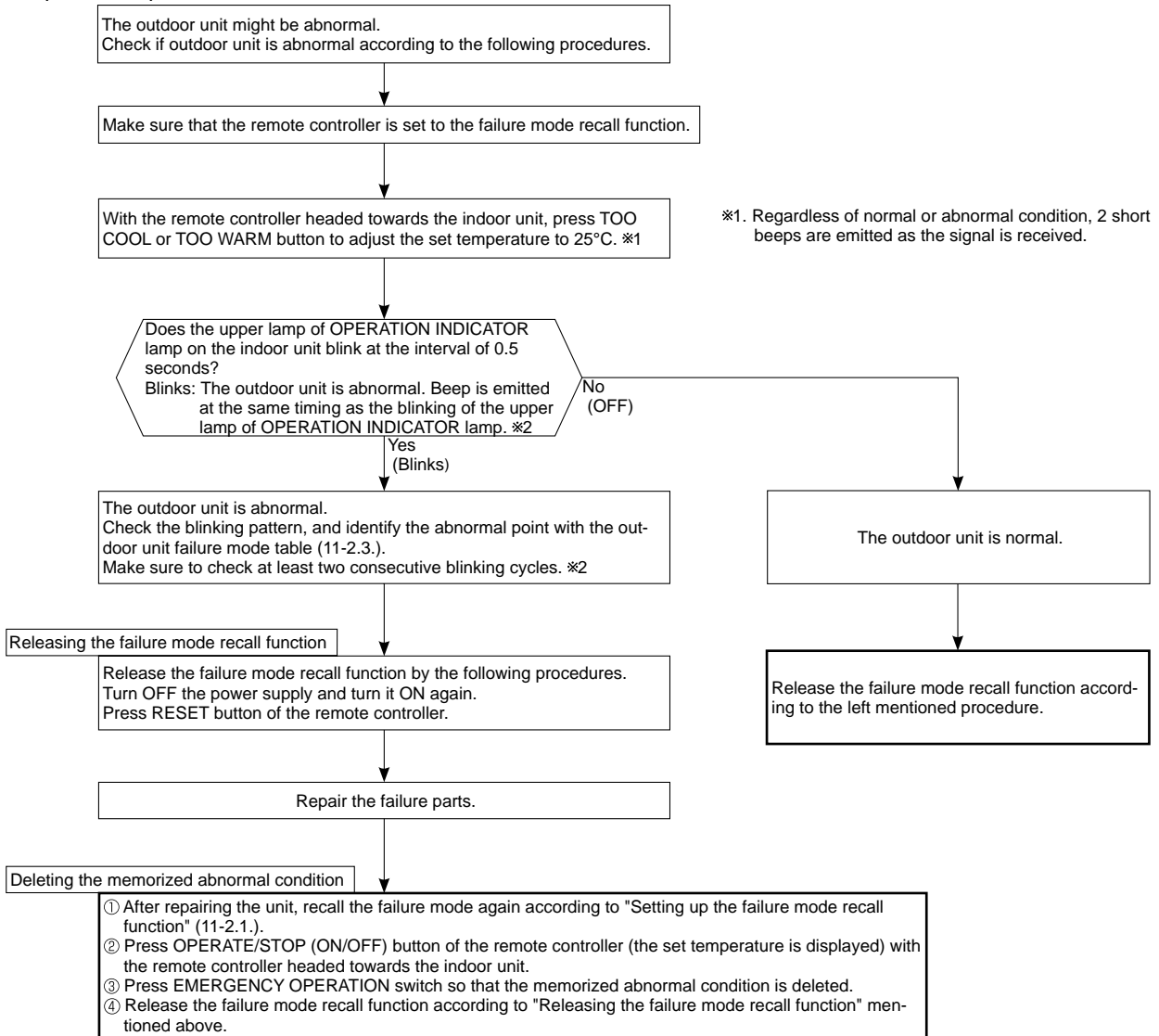

**NOTE:** 1. Make sure to release the failure mode recall function after it is set up, otherwise the unit cannot operate properly.  
2. If the abnormal condition is not deleted from the memory, the last abnormal condition is kept memorized.

\*2. Blinking pattern when outdoor unit is abnormal:

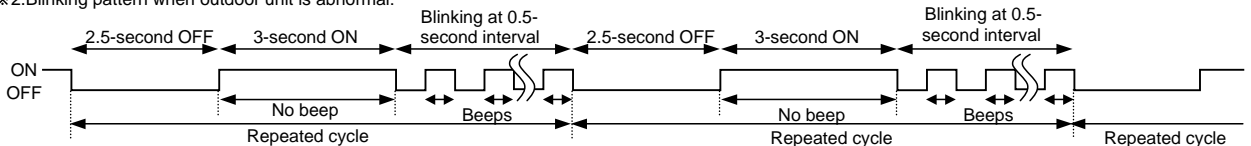

### 3. Outdoor unit failure mode table

The upper lamp of OPERATION INDICATOR lamp (Indoor unit)	Abnormal point (Failure mode/protection)	LED indication (Outdoor P.C. board)	Condition	Remedy	Indoor/outdoor unit failure mode recall function	Outdoor unit failure mode recall function
OFF	None (Normal)	—	—	—	—	—
1-time flash 2.5 seconds OFF	Indoor/outdoor communication, receiving error	—	Any signals from the inverter P.C. board cannot be received normally for 3 minutes.	•Refer to 11-5. ㉔ How to check miswiring and serial signal error.	○	○
	Indoor/outdoor communication, receiving error	—	Although the inverter P.C. board sends signal "0", signal "1" has been received 30 consecutive times.	•Refer to 11-5. ㉔ How to check miswiring and serial signal error.		
2-time flash 2.5 seconds OFF	Outdoor power system	—	Overcurrent protection cut-out operates 3 consecutive times within 1 minute after the compressor gets started.	•Reconnect connectors. •Refer to 11-5. ㉔ How to check inverter/compressor". •Check stop valve.	○	○
3-time flash 2.5 seconds OFF	Discharge temperature thermistor	1-time flash every 2.5 seconds	Thermistor shorts or opens during compressor running.	•Refer to 11-5. ㉔ "Check of outdoor thermistors". Defective outdoor thermistors can be identified by checking the blinking pattern of LED.	○	○
	Defrost thermistor	3-time flash 2.5 seconds OFF				
	Fin temperature thermistor	4-time flash 2.5 seconds OFF				
	P.C. board temperature thermistor	—				
4-time flash 2.5 seconds OFF	Overcurrent	11-time flash 2.5 seconds OFF	Large current flows into power module.	•Reconnect compressor connector. •Refer to 11-5. ㉔ How to check inverter/compressor". •Check stop valve.	—	○
	Compressor synchronous abnormality (Compressor start-up failure protection)	12-time flash 2.5 seconds OFF	Waveform of compressor current is distorted.	•Reconnect compressor connector. •Refer to 11-5. ㉔ How to check inverter/compressor".	—	○
5-time flash 2.5 seconds OFF	Discharge temperature	—	Temperature of discharge temperature thermistor exceeds 116°C, compressor stops. Compressor can restart if discharge temperature thermistor reads 100°C or less 3 minutes later.	•Check refrigerant circuit and refrigerant amount. •Refer to 11-5. ㉔ Check of LEV".	—	○
6-time flash 2.5 seconds OFF	High pressure	—	Temperature indoor coil thermistor exceeds 70°C in HEAT mode. Temperature defrost thermistor exceeds 70°C in COOL mode.	•Check refrigerant circuit and refrigerant amount. •Check stop valve.	—	○
7-time flash 2.5 seconds OFF	Fin temperature/ P.C. board temperature	7-time flash 2.5 seconds OFF	Temperature of fin temperature thermistor on the inverter P.C. board exceeds 80 °C (HJ25/35)/75 °C (HJ50), or temperature of P.C. board temperature thermistor on the inverter P.C. board exceeds 78 °C (HJ25/35)/80 °C (HJ50).	•Check around outdoor unit. •Check outdoor unit air passage. •Refer to 11-5. ㉔ Check of outdoor fan motor".	—	○
8-time flash 2.5 seconds OFF MUZ-HJ50VA	Outdoor fan motor	—	Outdoor fan has stopped 3 times in a row within 30 seconds after outdoor fan start-up.	•Refer to 11-5. ㉔ Check of outdoor fan motor". Refer to 11-5. ㉔ Check of inverter P.C. board".	—	○
9-time flash 2.5 seconds OFF	Nonvolatile memory data	5-time flash 2.5 seconds OFF	Nonvolatile memory data cannot be read properly.	•Replace the inverter P.C. board.	○	○
	Power module	6-time flash 2.5 seconds OFF	The interface short circuit occurs in the output of the power module (IC700). The compressor winding shorts circuit.	•Refer to 11-5. ㉔ How to check inverter/compressor".		
10-time flash 2.5 seconds OFF	Discharge temperature	—	Temperature of discharge temperature thermistor has been 50°C or less for 20 minutes.	•Refer to 11-5. ㉔ Check of LEV". •Check refrigerant circuit and refrigerant amount.	—	○
11-time flash 2.5 seconds OFF	DC voltage	8-time flash 2.5 seconds OFF	DC voltage of inverter cannot be detected normally.	•Refer to 11-5. ㉔ How to check inverter/compressor".	—	○
	Each phase current of compressor	9-time flash 2.5 seconds OFF	Each phase current of compressor cannot be detected normally.			
14-time flash 2.5 seconds OFF	Stop valve (Closed valve)	14-time flash 2.5 seconds OFF	Closed valve is detected by compressor current.	•Check stop valve.	○	○
	4-way valve/ Pipe temperature	16-time flash 2.5 seconds OFF	The 4-way valve does not work properly. The indoor coil thermistor detects an abnormal temperature.	•Check 4-way valve. •Replace inverter P.C. board.		

**NOTE:** Blinking patterns of this mode differ from the ones of TROUBLESHOOTING CHECK TABLE (11-3.).

### 11-3. TROUBLESHOOTING CHECK TABLE

No.	Symptom	LED indication	Abnormal point/Condition	Condition	Remedy	
1	Outdoor unit does not operate.	1-time flash every 2.5 seconds	Outdoor power system	Overcurrent protection cut-out operates 3 consecutive times within 1 minute after the compressor gets started, or failure of restart of compressor has repeated 24 times.	<ul style="list-style-type: none"> <li>Reconnect connector of compressor.</li> <li>Refer to 11-5.④ "How to check inverter/compressor".</li> <li>Check stop valve.</li> </ul>	
2			Outdoor thermistors	Discharge temperature thermistor, fin temperature thermistor, defrost thermistor, P.C. board temperature thermistor or outdoor heat exchanger temperature thermistor shorts or opens during compressor running.	<ul style="list-style-type: none"> <li>Refer to 11-5.⑥ "Check of outdoor thermistors".</li> </ul>	
3			Outdoor control system	Nonvolatile memory data cannot be read properly. (The upper lamp of OPERATION INDICATOR lamp of the indoor unit lights up or flashes 7-time.)	<ul style="list-style-type: none"> <li>Replace inverter P.C. board.</li> </ul>	
4			6-time flash 2.5 seconds OFF	Serial signal	The communication fails between the indoor and outdoor unit for 3 minutes.	<ul style="list-style-type: none"> <li>Refer to 11-5.⑩ "How to check miswiring and serial signal error."</li> </ul>
5			11-time flash 2.5 seconds OFF	Stop valve/ Closed valve	Closed valve is detected by compressor current.	<ul style="list-style-type: none"> <li>Check stop valve.</li> </ul>
6			14-time flash 2.5 seconds OFF	Outdoor unit (Other abnormality)	Outdoor unit is defective.	<ul style="list-style-type: none"> <li>Refer to 11-2.2. "Flow chart of the detailed outdoor unit failure mode recall function".</li> </ul>
7			16-time flash 2.5 seconds OFF	4-way valve/ Pipe temperature	The 4-way valve does not work properly. The indoor coil thermistor detects an abnormal temperature.	<ul style="list-style-type: none"> <li>Refer to 11-5.⑧ "Check of R.V. coil".</li> <li>Replace inverter P.C. board.</li> </ul>
8	'Outdoor unit stops and restarts 3 minutes later' is repeated.	2-time flash 2.5 seconds OFF	Overcurrent protection	Large current flows into power module. ※When overcurrent protection occurs within 10 seconds after compressor starts, compressor restarts after 15 seconds.	<ul style="list-style-type: none"> <li>Reconnect connector of compressor.</li> <li>Refer to 11-5.④ "How to check inverter/compressor".</li> <li>Check stop valve.</li> </ul>	
9			3-time flash 2.5 seconds OFF	Discharge temperature overheat protection	Temperature of discharge temperature thermistor exceeds 116 °C, compressor stops. Compressor can restart if discharge temperature thermistor reads 100°C or less 3 minutes later.	<ul style="list-style-type: none"> <li>Check refrigerant circuit and refrigerant amount.</li> <li>Refer to 11-5.⑧ "Check of LEV".</li> </ul>
10			4-time flash 2.5 seconds OFF	Fin temperature /P.C. board temperature thermistor overheat protection	Temperature of fin temperature thermistor on the heat sink exceeds 80 °C (HJ25/35)/75 °C (HJ50) or temperature of P.C. board temperature thermistor on the inverter P.C. board exceeds 78 °C (HJ25/35)/80 °C (HJ50).	<ul style="list-style-type: none"> <li>Check around outdoor unit.</li> <li>Check outdoor unit air passage.</li> <li>Refer to 11-5.① "Check of outdoor fan motor".</li> </ul>
11			5-time flash 2.5 seconds OFF	High pressure protection	Indoor coil thermistor exceeds 70°C in HEAT mode. Defrost thermistor exceeds 70 °C in COOL mode.	<ul style="list-style-type: none"> <li>Check refrigerant circuit and refrigerant amount.</li> <li>Check stop valve.</li> </ul>
12			8-time flash 2.5 seconds OFF	Compressor synchronous abnormality	The waveform of compressor current is distorted.	<ul style="list-style-type: none"> <li>Reconnect connector of compressor.</li> <li>Refer to 11-5.④ "How to check inverter/compressor".</li> </ul>
13			10-time flash 2.5 seconds OFF MUZ-HJ50VA	Outdoor fan motor	Outdoor fan has stopped 3 times in a row within 30 seconds after outdoor fan start-up.	<ul style="list-style-type: none"> <li>Refer to 11-5.① "Check of outdoor fan motor."</li> <li>Refer to 11-5.① "Check of inverter P.C. board."</li> </ul>
14			12-time flash 2.5 seconds OFF	Each phase current of compressor	Each phase current of compressor cannot be detected normally.	<ul style="list-style-type: none"> <li>Refer to 11-5.④ "How to check inverter/compressor".</li> </ul>
15			13-time flash 2.5 seconds OFF	DC voltage	DC voltage of inverter cannot be detected normally.	<ul style="list-style-type: none"> <li>Refer to 11-5.④ "How to check inverter/compressor".</li> </ul>
16			Outdoor unit operates.	1-time flash 2.5 seconds OFF	Frequency drop by current protection	When the input current exceeds 5.4 A (HJ25)/6.1 A (HJ35)/9.2 A (HJ50), compressor frequency lowers.
17	3-time flash 2.5 seconds OFF	Frequency drop by high pressure protection			Temperature of indoor coil thermistor exceeds 55 °C in HEAT mode, compressor frequency lowers.	
		Frequency drop by defrosting in COOL mode			Indoor coil thermistor reads 8 °C or less in COOL mode, compressor frequency lowers.	
18	4-time flash 2.5 seconds OFF	Frequency drop by discharge temperature protection			Temperature of discharge temperature thermistor exceeds 111 °C, compressor frequency lowers.	
19	5-time flash 2.5 seconds OFF	Outside temperature thermistor protection	When the outside temperature thermistor shorts or opens, protective operation without that thermistor is performed.	<ul style="list-style-type: none"> <li>Refer to 11-5. ⑥ Check of outdoor thermistors.</li> </ul>		
20	Outdoor unit operates.	7-time flash 2.5 seconds OFF	Low discharge temperature protection	Temperature of discharge temperature thermistor has been 50°C or less for 20 minutes.	<ul style="list-style-type: none"> <li>Refer to 11-5.⑧ "Check of LEV".</li> <li>Check refrigerant circuit and refrigerant amount.</li> </ul>	
21			8-time flash 2.5 seconds OFF	PAM protection PAM: Pulse Amplitude Modulation	The overcurrent flows into IC821 (Switching power transistor) (HJ25/35)/IC820 (Power module) (HJ50) or the bus-bar voltage reaches 320 V or more, PAM stops and restarts.	This is not malfunction. PAM protection will be activated in the following cases: <ol style="list-style-type: none"> <li>Instantaneous power voltage drop. (Short time power failure)</li> <li>When the power supply voltage is high.</li> </ol>
22			9-time flash 2.5 seconds OFF	Inverter check mode	The connector of compressor is disconnected, inverter check mode starts.	<ul style="list-style-type: none"> <li>Check if the connector of the compressor is correctly connected.</li> <li>Refer to 11-5.④ "How to check inverter/compressor".</li> </ul>

NOTE: 1. The location of LED is illustrated at the right figure. Refer to 11-6.1.  
2. LED is lighted during normal operation.

The flashing frequency shows the number of times the LED blinks after every 2.5-second OFF.  
(Example) When the flashing frequency is "2".

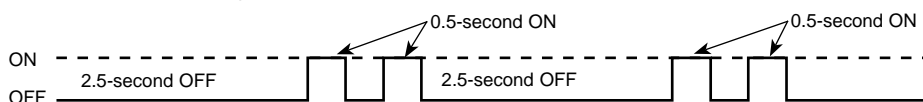

Inverter P.C. board  
MUZ-HJ25/35

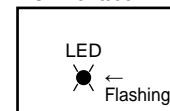

Inverter P.C. board  
MUZ-HJ50

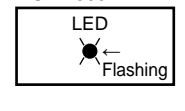

**11-4. TROUBLE CRITERION OF MAIN PARTS**  
**MUZ-HJ25VA MUZ-HJ35VA MUZ-HJ50VA**

Part name	Check method and criterion	Figure													
Defrost thermistor (RT61)	Measure the resistance with a tester. Refer to 11-6. "Test point diagram and voltage", 1. "Inverter P.C. board", for the chart of thermistor.														
Discharge temperature thermistor (RT62) Fin temperature thermistor (RT64)	Measure the resistance with a tester. Before measurement, hold the thermistor with your hands to warm it up. Refer to 11-6. "Test point diagram and voltage", 1. "Inverter P.C. board", for the chart of thermistor.														
Compressor (MC)	Measure the resistance between the terminals with a tester. (Part temperature -10 ~ 40°C) <table border="1" style="margin-left: 20px;"> <thead> <tr> <th colspan="4">Normal</th> </tr> <tr> <th>U-V</th> <th>MUZ-HJ25VA</th> <th>MUZ-HJ35VA</th> <th>MUZ-HJ50VA</th> </tr> </thead> <tbody> <tr> <td>U-W</td> <td rowspan="2">2.01 ~ 2.86 Ω</td> <td rowspan="2">1.20 ~ 1.72 Ω</td> <td rowspan="2">0.78 ~ 1.11 Ω</td> </tr> <tr> <td>V-W</td> </tr> </tbody> </table>	Normal				U-V	MUZ-HJ25VA	MUZ-HJ35VA	MUZ-HJ50VA	U-W	2.01 ~ 2.86 Ω	1.20 ~ 1.72 Ω	0.78 ~ 1.11 Ω	V-W	
Normal															
U-V	MUZ-HJ25VA	MUZ-HJ35VA	MUZ-HJ50VA												
U-W	2.01 ~ 2.86 Ω	1.20 ~ 1.72 Ω	0.78 ~ 1.11 Ω												
V-W															
<b>MUZ-HJ25VA</b> <b>MUZ-HJ35VA</b> Outdoor fan motor (MF) INNER FUSE RA6V21-AB 152 <sup>+0</sup> / <sub>-5</sub> °C CUT OFF RA6V21-BB 126 ± 2: CUT OFF	Measure the resistance between the terminals with a tester. (Part temperature -10 ~ 40°C) <b>MUZ-HJ25VA MUZ-HJ35VA</b> <table border="1" style="margin-left: 20px;"> <thead> <tr> <th rowspan="2">Color of lead wire</th> <th colspan="2">Normal</th> </tr> <tr> <th>RA6V21-AB</th> <th>RA6V21-BB, BD</th> </tr> </thead> <tbody> <tr> <td>WHT – BLK</td> <td>305 ~ 374 Ω</td> <td>222 ~ 272 Ω</td> </tr> <tr> <td>BLK – RED</td> <td>247 ~ 304 Ω</td> <td>245 ~ 300 Ω</td> </tr> </tbody> </table>	Color of lead wire	Normal		RA6V21-AB	RA6V21-BB, BD	WHT – BLK	305 ~ 374 Ω	222 ~ 272 Ω	BLK – RED	247 ~ 304 Ω	245 ~ 300 Ω			
Color of lead wire	Normal														
	RA6V21-AB	RA6V21-BB, BD													
WHT – BLK	305 ~ 374 Ω	222 ~ 272 Ω													
BLK – RED	247 ~ 304 Ω	245 ~ 300 Ω													
<b>MUZ-HJ50VA</b> Outdoor fan motor (MF)	<b>MUZ-HJ50VA</b> <table border="1" style="margin-left: 20px;"> <thead> <tr> <th>Color of lead wire</th> <th>Normal</th> </tr> </thead> <tbody> <tr> <td>RED – BLK</td> <td rowspan="3">30 ~ 43 Ω</td> </tr> <tr> <td>BLK – WHT</td> </tr> <tr> <td>WHT – RED</td> </tr> </tbody> </table>	Color of lead wire	Normal	RED – BLK	30 ~ 43 Ω	BLK – WHT	WHT – RED								
Color of lead wire	Normal														
RED – BLK	30 ~ 43 Ω														
BLK – WHT															
WHT – RED															
R.V. coil (21S4)	Measure the resistance between the terminals with a tester. (Part temperature -10°C ~ 40°C) <table border="1" style="margin-left: 20px;"> <thead> <tr> <th colspan="2">Normal</th> </tr> <tr> <th>MUZ-HJ25VA/35VA</th> <th>MUZ-HJ50VA</th> </tr> </thead> <tbody> <tr> <td>1.19 ~ 1.78 kΩ</td> <td>1.41 ~ 2.00 kΩ</td> </tr> </tbody> </table>	Normal		MUZ-HJ25VA/35VA	MUZ-HJ50VA	1.19 ~ 1.78 kΩ	1.41 ~ 2.00 kΩ								
Normal															
MUZ-HJ25VA/35VA	MUZ-HJ50VA														
1.19 ~ 1.78 kΩ	1.41 ~ 2.00 kΩ														
<b>MUZ-HJ25VA</b> <b>MUZ-HJ50VA</b> Expansion valve coil (LEV)	Measure the resistance using a tester. (Temperature: -10 ~ 40°C) <table border="1" style="margin-left: 20px;"> <thead> <tr> <th>Color of lead wire</th> <th>Normal (Ω)</th> </tr> </thead> <tbody> <tr> <td>RED – ORN</td> <td rowspan="4">37 ~ 54</td> </tr> <tr> <td>RED – WHT</td> </tr> <tr> <td>RED – BLU</td> </tr> <tr> <td>RED – YLW</td> </tr> </tbody> </table>	Color of lead wire	Normal (Ω)	RED – ORN	37 ~ 54	RED – WHT	RED – BLU	RED – YLW							
Color of lead wire	Normal (Ω)														
RED – ORN	37 ~ 54														
RED – WHT															
RED – BLU															
RED – YLW															
<b>MUZ-HJ35VA</b> Expansion valve coil (LEV)	Measure the resistance using a tester. (Part temperature: -10 ~ 40°C) <table border="1" style="margin-left: 20px;"> <thead> <tr> <th>Color of lead wire</th> <th>Normal</th> </tr> </thead> <tbody> <tr> <td>WHT – RED</td> <td rowspan="4">37 ~ 54 Ω</td> </tr> <tr> <td>RED – ORN</td> </tr> <tr> <td>YLW – BRN</td> </tr> <tr> <td>BRN – BLU</td> </tr> </tbody> </table>	Color of lead wire	Normal	WHT – RED	37 ~ 54 Ω	RED – ORN	YLW – BRN	BRN – BLU							
Color of lead wire	Normal														
WHT – RED	37 ~ 54 Ω														
RED – ORN															
YLW – BRN															
BRN – BLU															

## 11-5. TROUBLESHOOTING FLOW

### Ⓐ How to check inverter/compressor

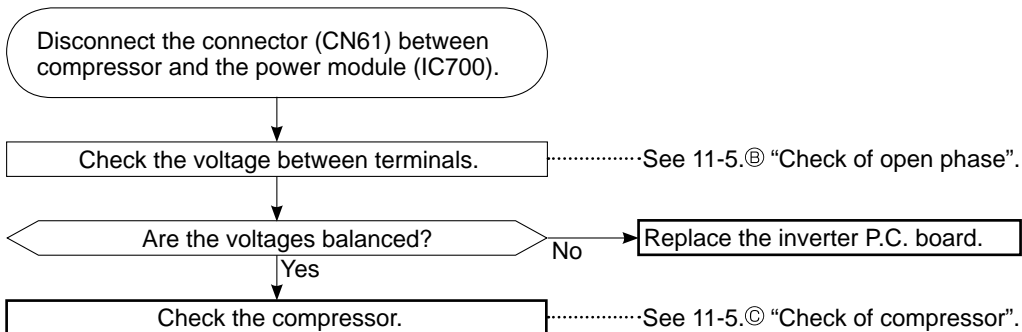

### Ⓑ Check of open phase

- With the connector between the compressor and the power module disconnected, activate the inverter and check if the inverter is normal by measuring **the balance of voltage** between the terminals.

Output voltage is 50 - 130 V. (The voltage may differ according to the tester.)

<< Operation method >>

Start cooling or heating operation by pressing EMERGENCY OPERATION switch on the indoor unit. (TEST RUN OPERATION : Refer to 8-3.)

<< Measurement point >>

At 3 points

BLK (U)-WHT (V)

BLK (U)-RED (W)

WHT(V)-RED (W)

※ Measure AC voltage between the lead wires at 3 points.

**NOTE** : 1. Output voltage varies according to power supply voltage.

2. Measure the voltage by analog type tester.

3. During this check, LED of the inverter P.C. board flashes 9 times. (Refer to 11-6.1.)

### C Check of compressor

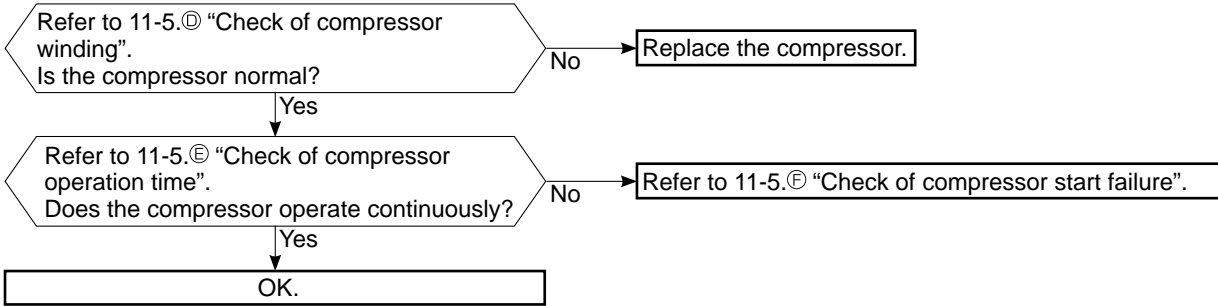

### D Check of compressor winding

- Disconnect the connector (CN61) between the compressor and power module, and measure the resistance between the compressor terminals.

<<Measurement point>>

At 3 points  
BLK-WHT  
BLK-RED  
WHT-RED

※ Measure the resistance between the lead wires at 3 points.

<<Judgement>>

Refer to 11-4.

0 [Ω] .....Abnormal [short]

Infinite [Ω] .....Abnormal [open]

**NOTE** : Be sure to zero the ohmmeter before measurement.

### E Check of compressor operation time

- Connect the compressor and activate the inverter. Then measure the time until the inverter stops due to over current.

<<Operation method>>

Start heating or cooling operation by pressing EMERGENCY OPERATION switch on the indoor unit.  
(TEST RUN OPERATION: Refer to 8-3.)

<<Measurement>>

Measure the time from the start of compressor to the stop of compressor due to overcurrent.

<<Judgement>>

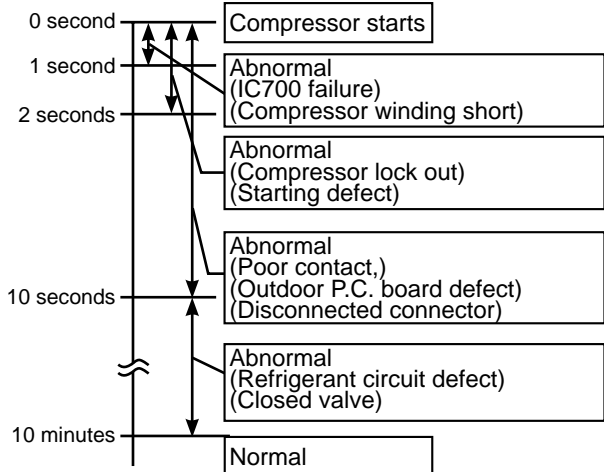



## F Check of compressor start failure

Make sure that ①~④ is normal.

### •Electrical circuit check

- ①. Contact of the compressor connector (Including CN61)
- ②. Output voltage of inverter P.C. board and balance of them (See 11-5.⑥)
- ③. Direct current voltage between DB61(+) and (-) on the inverter P.C. board
- ④. Voltage between outdoor terminal block S1-S2

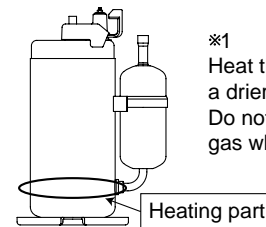
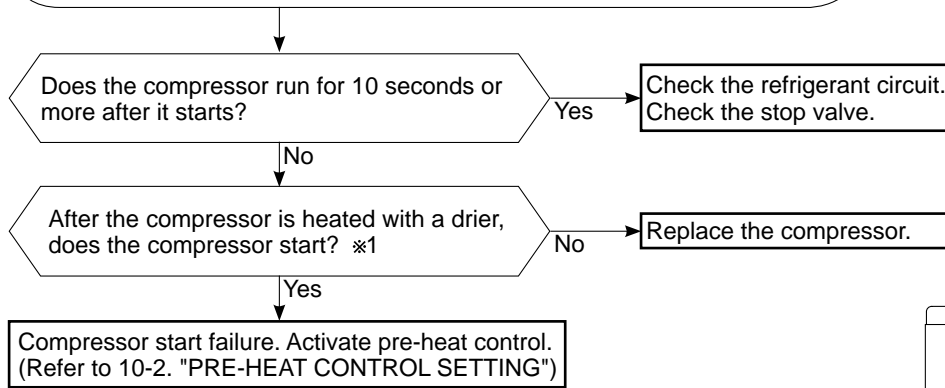

※1  
Heat the compressor with a drier for about 20 minutes. Do not recover refrigerant gas while heating.

## G Check of outdoor thermistors

Disconnect the connector of thermistor in the inverter P.C. board (see below table), and measure the resistance of thermistor.

Is the thermistor normal? (Refer to 11-6.1.)

No → Replace the thermistor except RT64. When RT64 is abnormal, replace the inverter P.C. board.

Reconnect the connector of thermistor. Turn ON the power supply and press EMERGENCY OPERATION switch.

Does the unit operate for 10 minutes or more without showing thermistor abnormality?

No → Replace the inverter P.C. board.

OK.  
(Cause is poor contact.)

Thermistor	Symbol	Connector, Pin No.	Board
Defrost	RT61	Between CN641 pin 1 and pin 2	Inverter P.C. board
Discharge temperature	RT62	Between CN641 pin 3 and pin 4	
Fin temperature	RT64	Between CN642 pin 1 and pin 2	
Outdoor heat exchanger temperature ※	RT68	Between CN644 pin 1 and pin 3	

※ MUZ-HJ50VA only.

## H Check of R.V. coil

- ※ First of all, measure the resistance of R.V. coil to check if the coil is defective. Refer to 11-4.
- ※ In case CN721 is not connected or R.V. coil is open, voltage is generated between the terminal pins of the connector although any signal is not being transmitted to R.V. coil.  
Check if CN721 is connected.

### MUZ-HJ25VA MUZ-HJ35VA

#### Unit operates COOL mode even if it is set to HEAT mode.

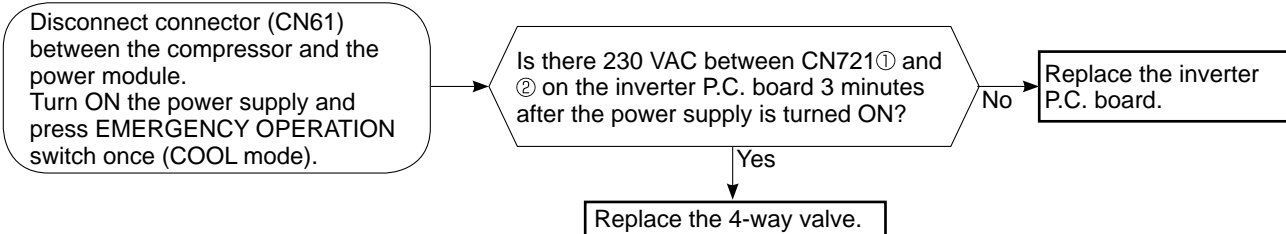

#### Unit operates HEAT mode even if it is set to COOL mode.

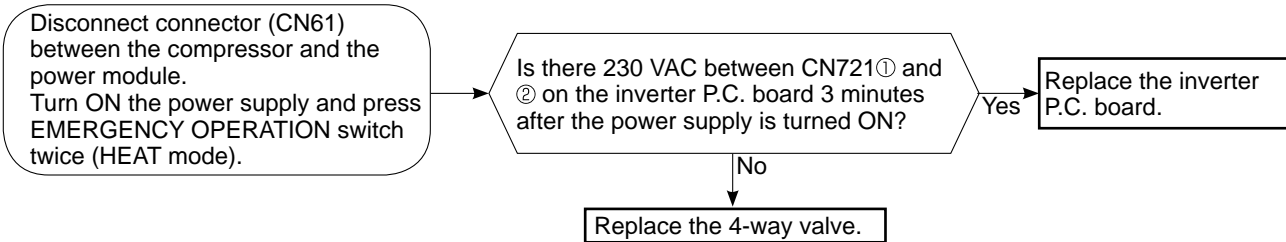

### MUZ-HJ50VA

#### Unit operates COOL mode even if it is set to HEAT mode.

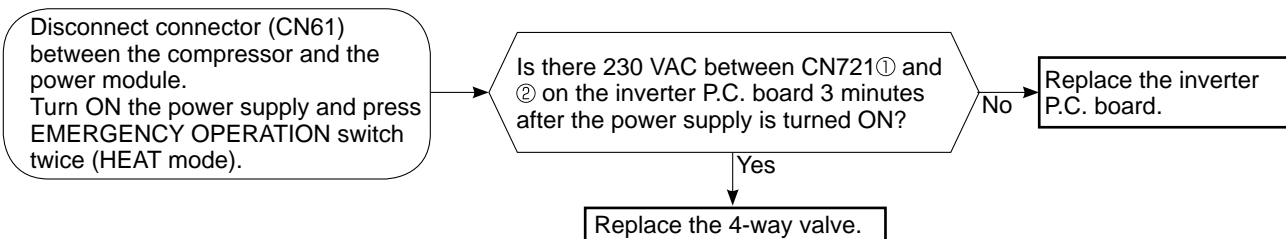

#### Unit operates HEAT mode even if it is set to COOL mode.

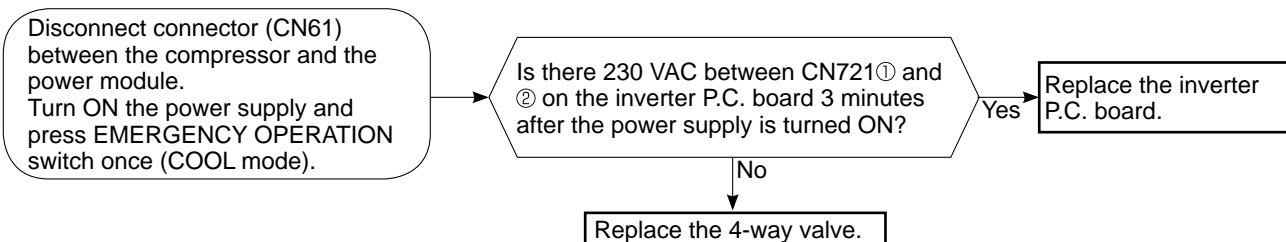

**① Check of outdoor fan motor**

**MUZ-HJ25VA MUZ-HJ35VA**

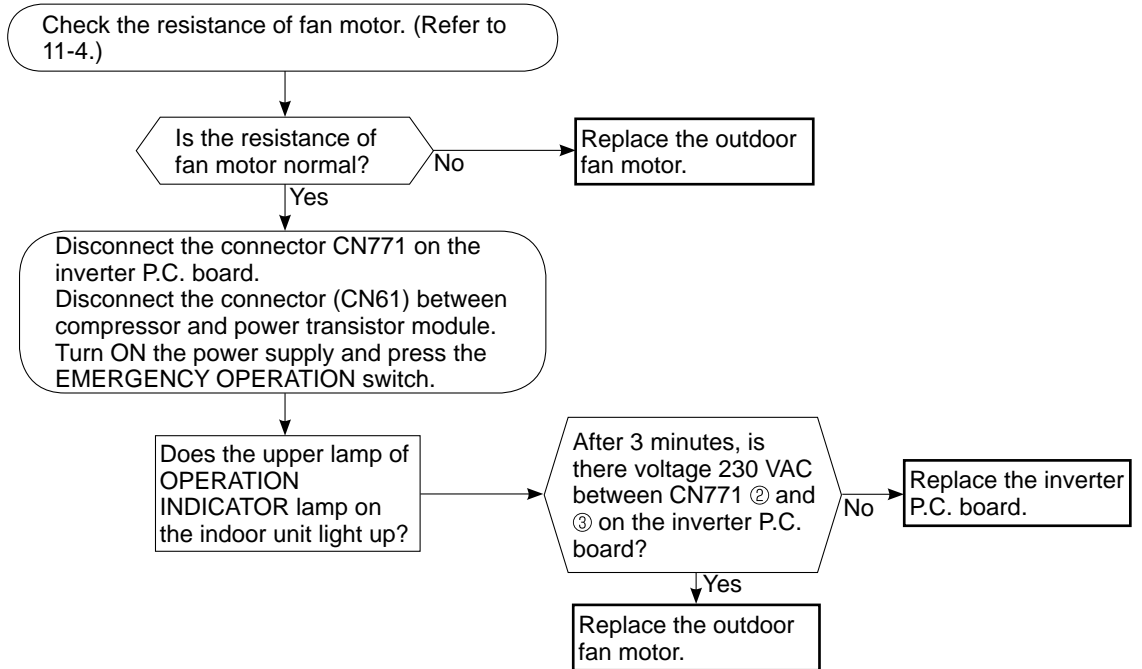

**MUZ-HJ50VA**

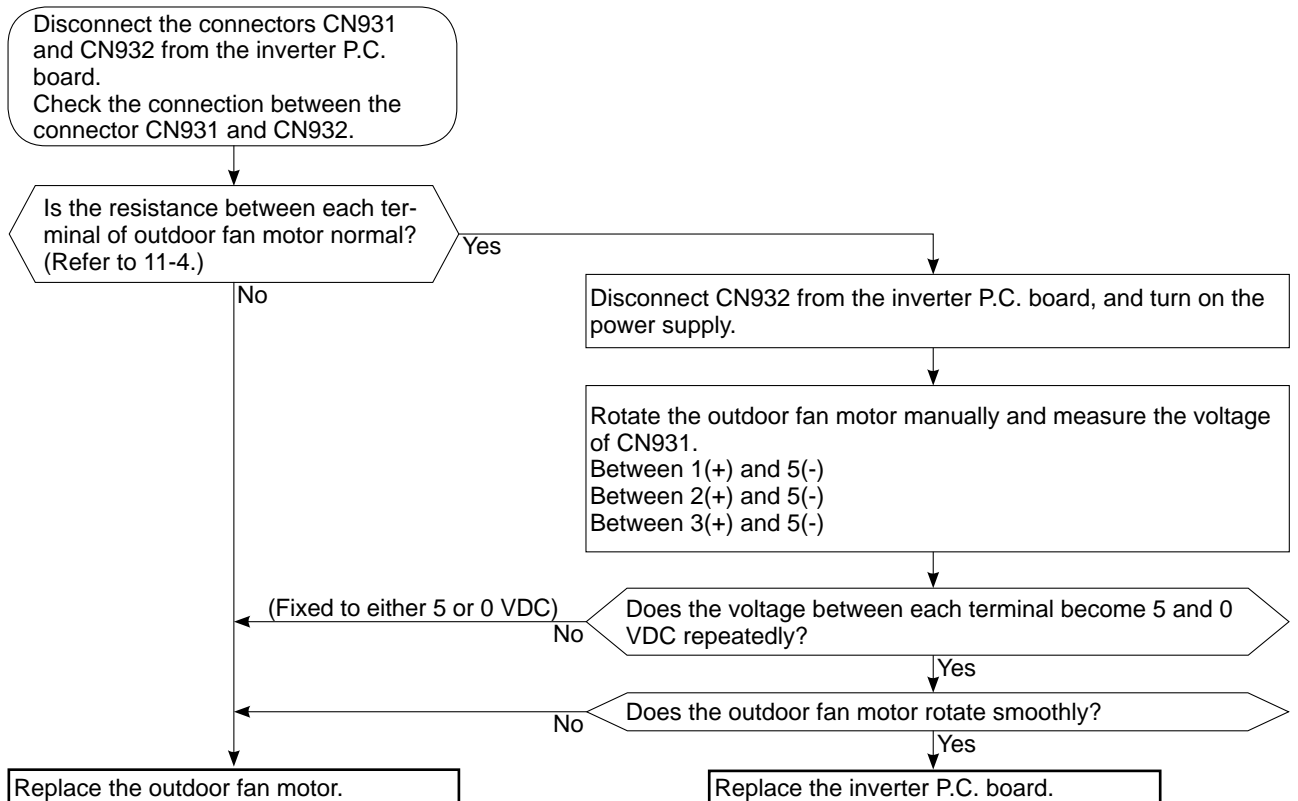

## J Check of power supply

Disconnect the connector (CN61) between compressor and power module.  
Turn ON power supply and press EMERGENCY OPERATION switch.

Does the upper lamp of OPERATION INDICATOR lamp on the indoor unit light up?

No

Rectify indoor/outdoor connecting wire.

Yes

Is there voltage 230 VAC between the indoor terminal block S1 and S2?

No

Replace the indoor electronic control P.C. board.

Yes

Is there voltage 250 - 370 VDC between DB61 (+) and DB61 (-) on the inverter P.C. board? (Refer to 11-6.1.)

Yes

Does LED on the inverter P.C. board light up or flash? (Refer to 11-6.1.)

No

Replace the inverter P.C. board.

No

Check the electric parts in main circuit.

If light up, OK.  
If flash, refer to 11-3.

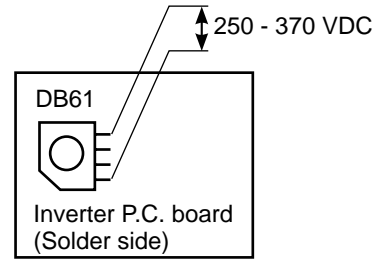

## K Check of LEV (Expansion valve)

Turn ON the power supply.  
<Preparation of the remote controller>  
① While pressing both OPERATION SELECT button and TOO COOL button on the remote controller at the same time, press RESET button.  
② First, release RESET button.  
Hold down the other two buttons for another 3 seconds. Make sure that the indicators on the LCD screen shown in the right figure are all displayed. Then release the buttons.

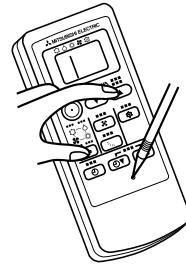

Press OPERATE/STOP (ON/OFF) button of the remote controller (the set temperature is displayed) with the remote controller headed towards the indoor unit. \*1

Expansion valve operates in full-opening direction.

Do you hear the expansion valve "click, click....." ?  
Do you feel the expansion valve vibrate on touching it ?

Yes

OK

No

Is LEV coil properly fixed to the expansion valve?

No

Properly fix the LEV coil to the expansion valve.

Yes

Does the resistance of LEV coil have the characteristics? (Refer to 11-4.)

Yes

Measure each voltage between connector pins of CN724 on the inverter P.C. board.  
1. Pin③(-) — Pin①(+)  
2. Pin④(-) — Pin①(+)  
3. Pin⑤(-) — Pin①(+)  
4. Pin⑥(-) — Pin①(+)  
Is there about 3 ~ 5 VAC between each?  
**NOTE:** Measure the voltage by an analog tester.

No

Replace the inverter P.C. board.

No

Replace the LEV coil.

Yes

Replace the expansion valve.

\*1. Regardless of normal or abnormal condition, a short beep is emitted once the signal is received.

**NOTE :** After check of LEV, do the undermentioned operations.  
1. Turn OFF the power supply and turn ON it again.  
2. Press RESET button on the remote controller.



**Ⓐ Check of inverter P.C. board**

**MUZ-HJ50VA**

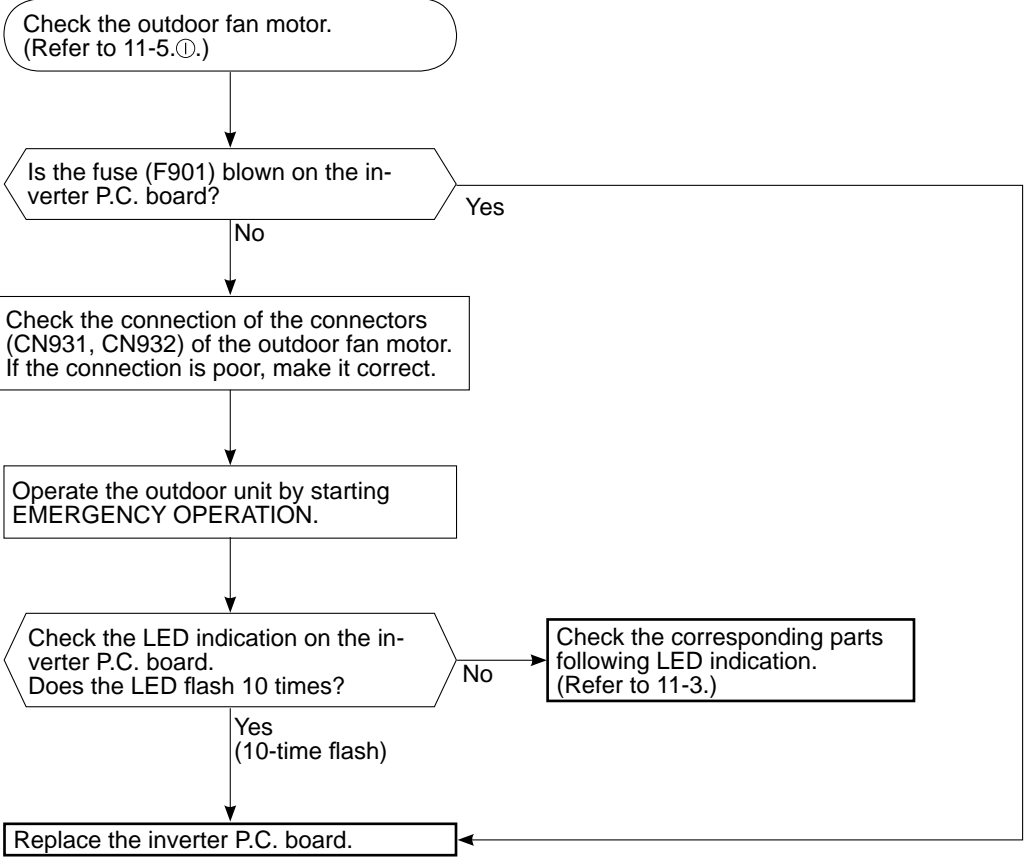

## M How to check miswiring and serial signal error

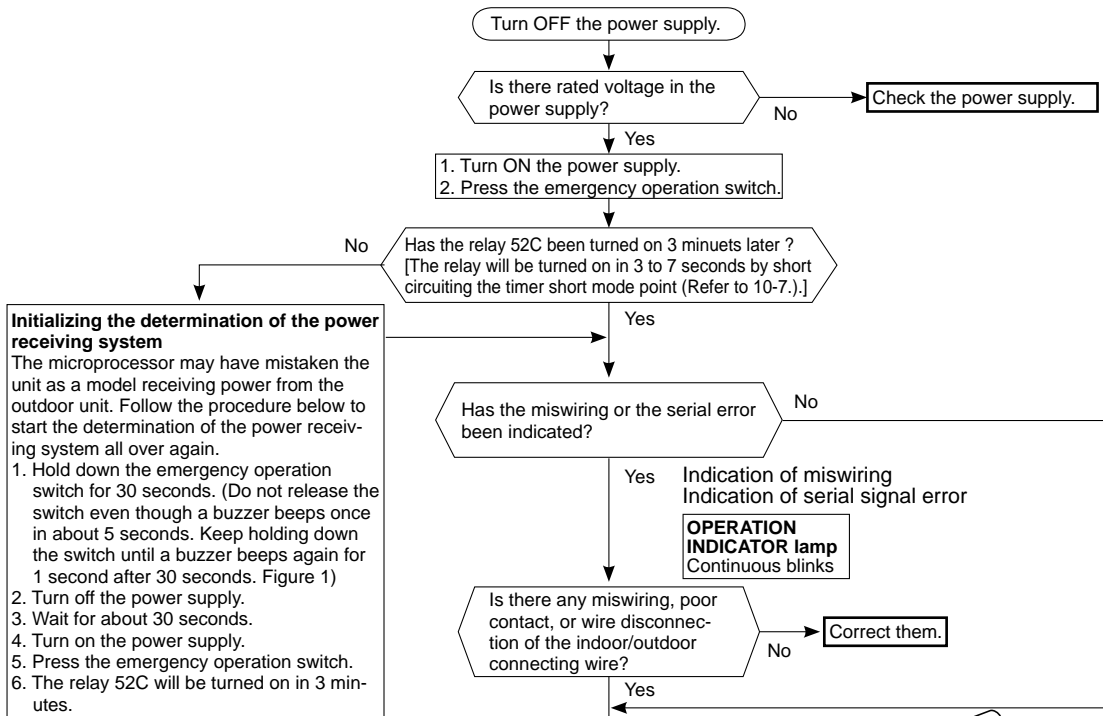
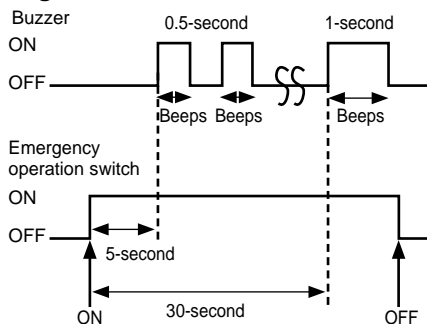

Figure 1



Turn OFF the power supply. Make sure again that the indoor/outdoor connecting wire is correctly connected. With the indoor/outdoor connecting wire connected, short circuit between S2 and S3 on the outdoor terminal block. \*1

<Preparation of the remote controller>

- ① While pressing both OPERATION SELECT button and TOO COOL button on the remote controller at the same time, press RESET button.
- ② First, release RESET button. Hold down the other two buttons for another 3 seconds. Make sure that the indicators on the LCD screen shown in the right figure are all displayed. Then release the buttons. (Setting up the failure mode recall function)

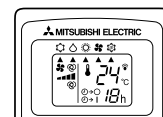
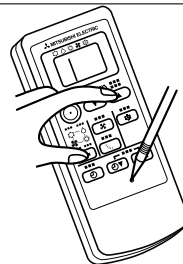

Aim the remote controller at the indoor unit, and press OPERATE/STOP (ON/OFF) button. The relay 52C will be turned on, and the outdoor unit will be energized.

\*1 Make sure that the wiring is correct. If the procedure is performed without correcting miswiring, it may lead to damage to the P.C. board.

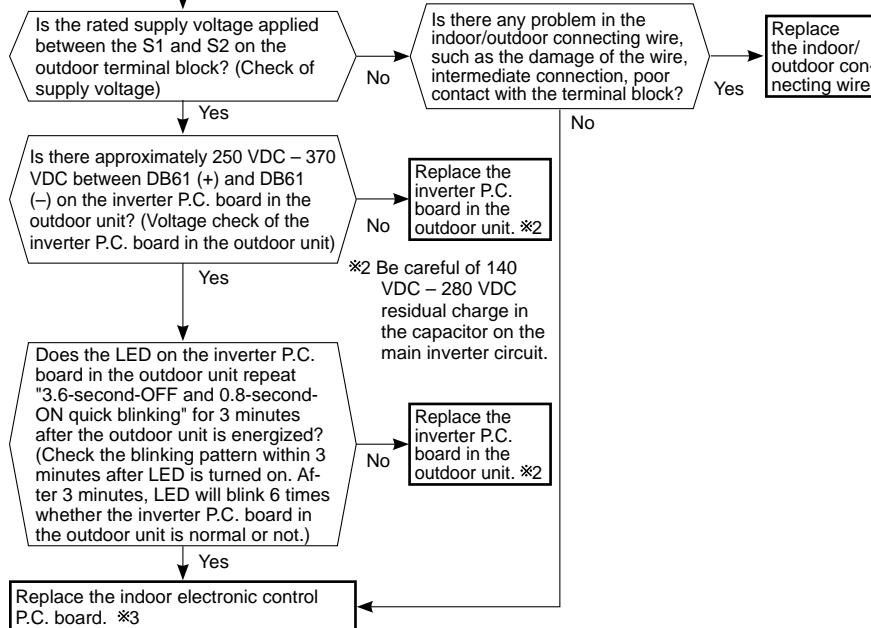
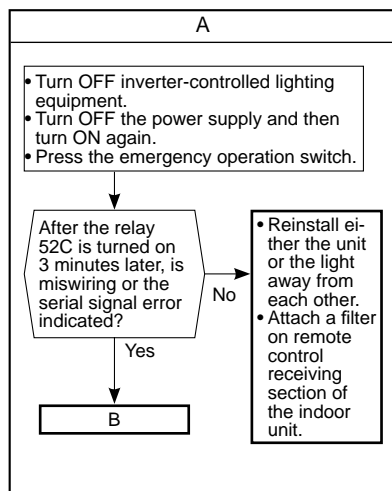

\*2 Be careful of 140 VDC – 280 VDC residual charge in the capacitor on the main inverter circuit.

\*3 Be sure to release the failure-mode recall function after checking.



**N Electromagnetic noise enters into TV sets or radios**

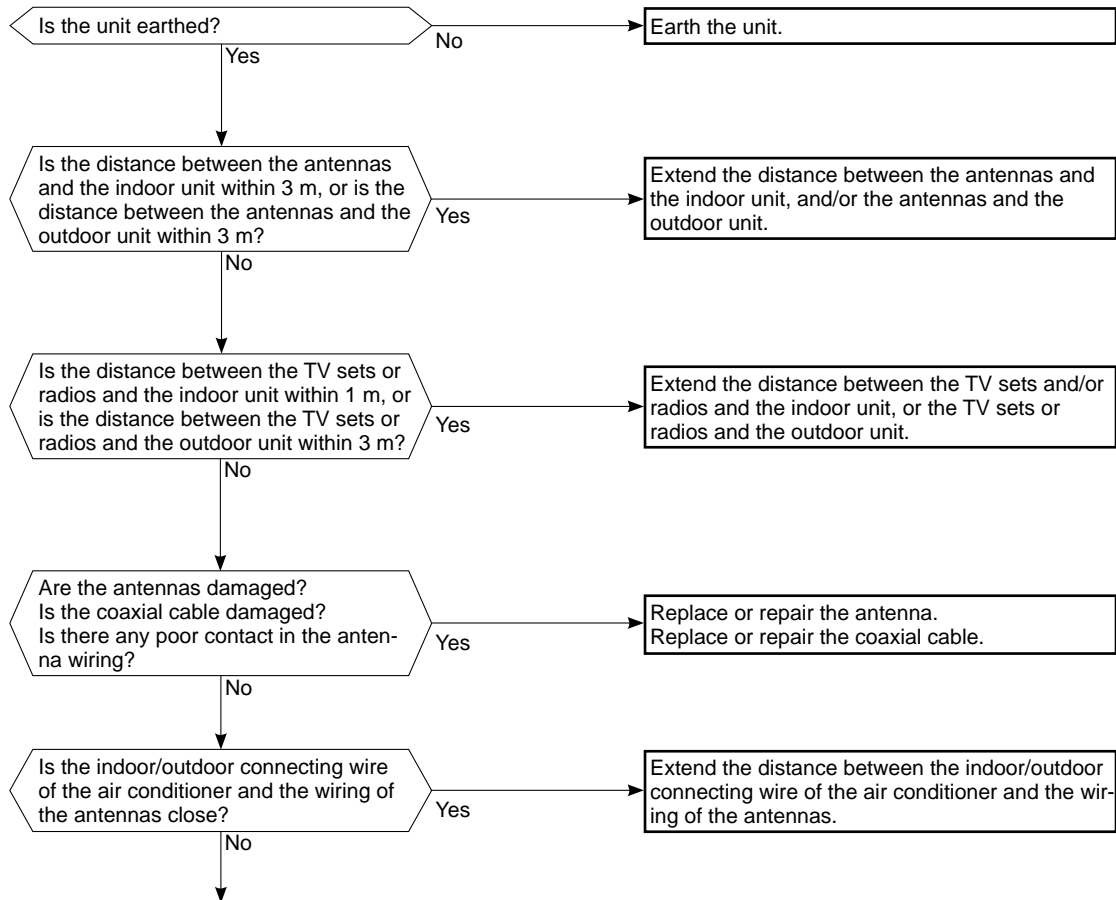

Even if all of the above conditions are fulfilled, the electromagnetic noise may enter, depending on the electric field strength or the installation condition (combination of specific conditions such as antennas or wiring). Check the following before asking for service.

1. Devices affected by the electromagnetic noise  
TV sets, radios (FM/AM broadcast, shortwave)
2. Channel, frequency, broadcast station affected by the electromagnetic noise
3. Channel, frequency, broadcast station unaffected by the electromagnetic noise
4. Layout of ;  
indoor/outdoor unit of the air conditioner, indoor/outdoor wiring, earth wire, antennas, wiring from antennas, receiver
5. Electric field intensity of the broadcast station affected by the electromagnetic noise
6. Presence or absence of amplifier such as booster
7. Operation condition of air conditioner when the electromagnetic noise enters in
  - 1) Turn OFF the power supply once, and then turn ON the power supply. In this situation, check for the electromagnetic noise.
  - 2) Within 3 minutes after turning ON the power supply, press OPERATE/STOP (ON/OFF) button on the remote controller for power ON, and check for the electromagnetic noise.
  - 3) After a short time (3 minutes later after turning ON), the outdoor unit starts running. During operation, check for the electromagnetic noise.
  - 4) Press OPERATE/STOP (ON/OFF) button on the remote controller for power OFF, when the outdoor unit stops but the indoor/outdoor communication still runs on. In this situation, check for the electromagnetic noise.

# 11-6. TEST POINT DIAGRAM AND VOLTAGE

## 1. Inverter P.C. board

### MUZ-HJ25VA MUZ-HJ35VA

Back side of unit

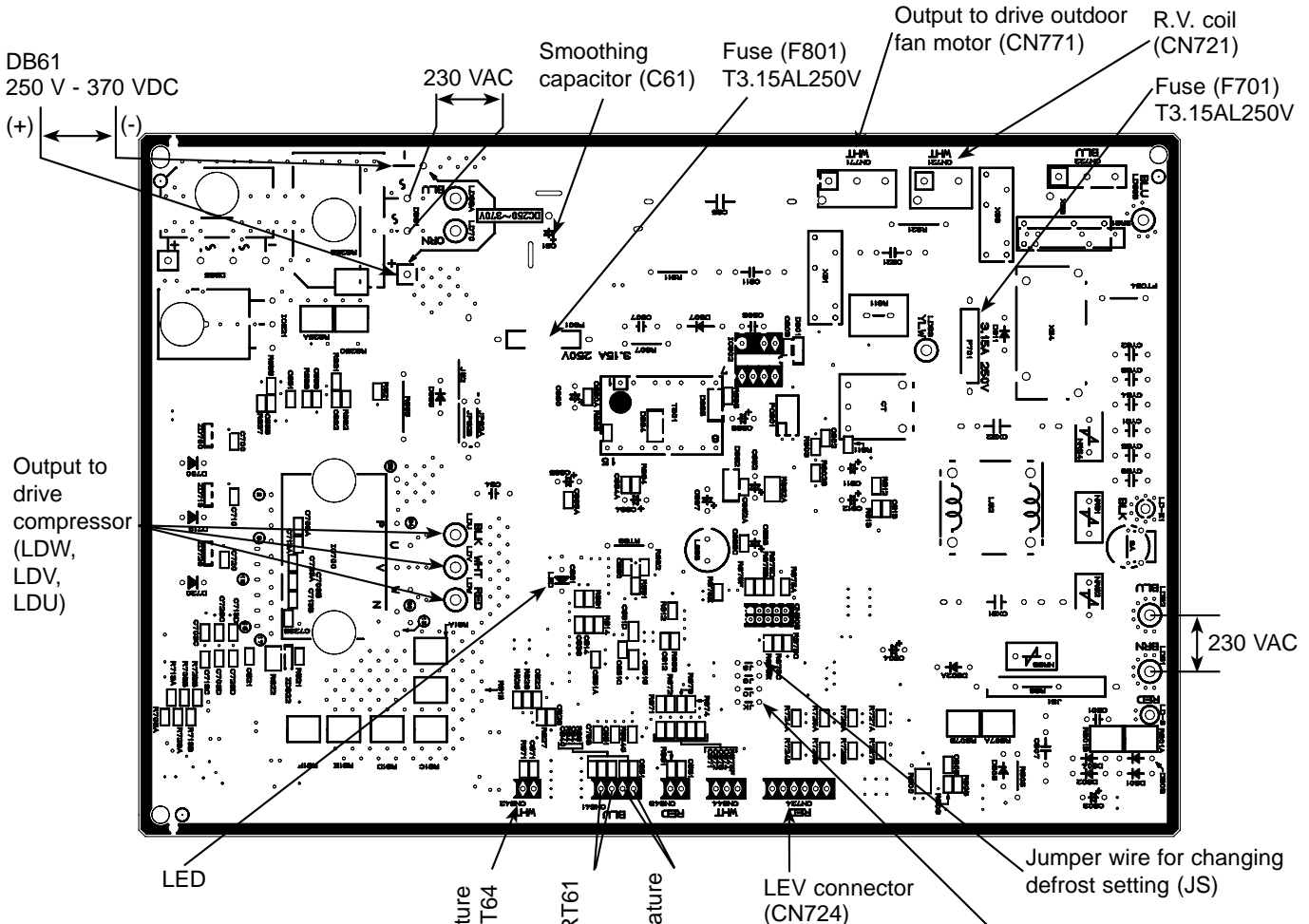

Front side of unit

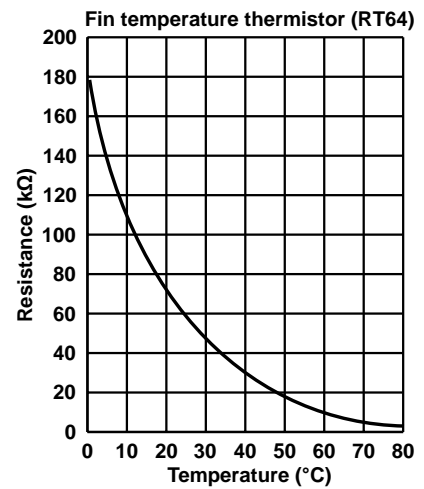
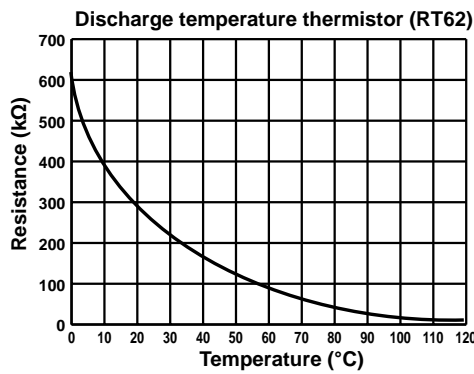
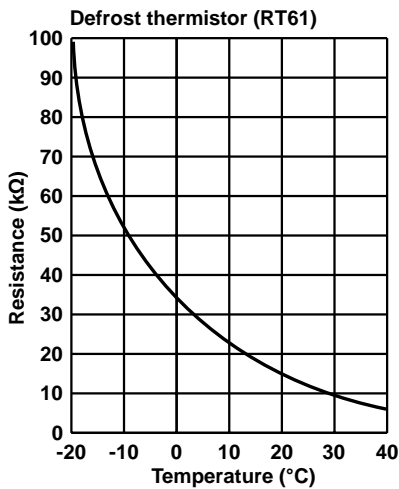



# MUZ-HJ50VA

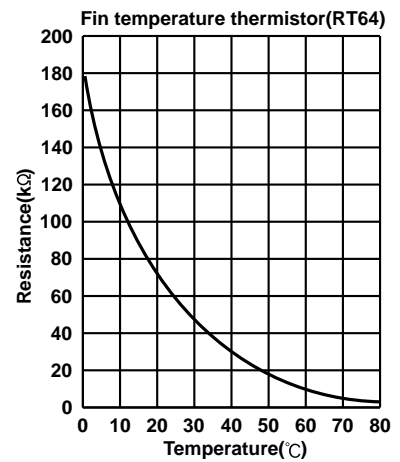
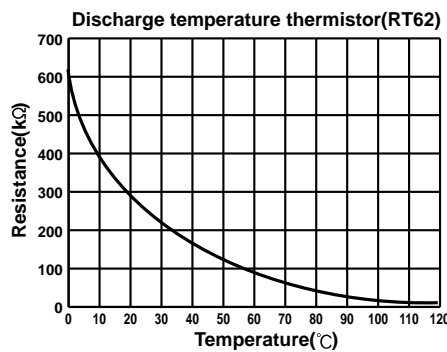
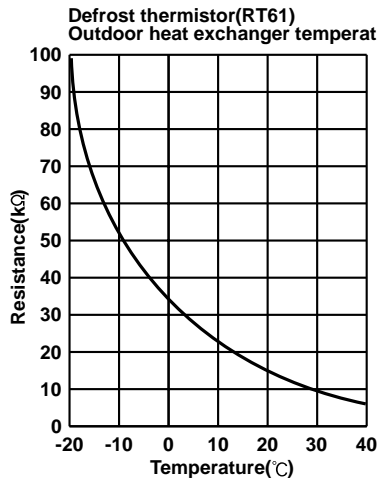
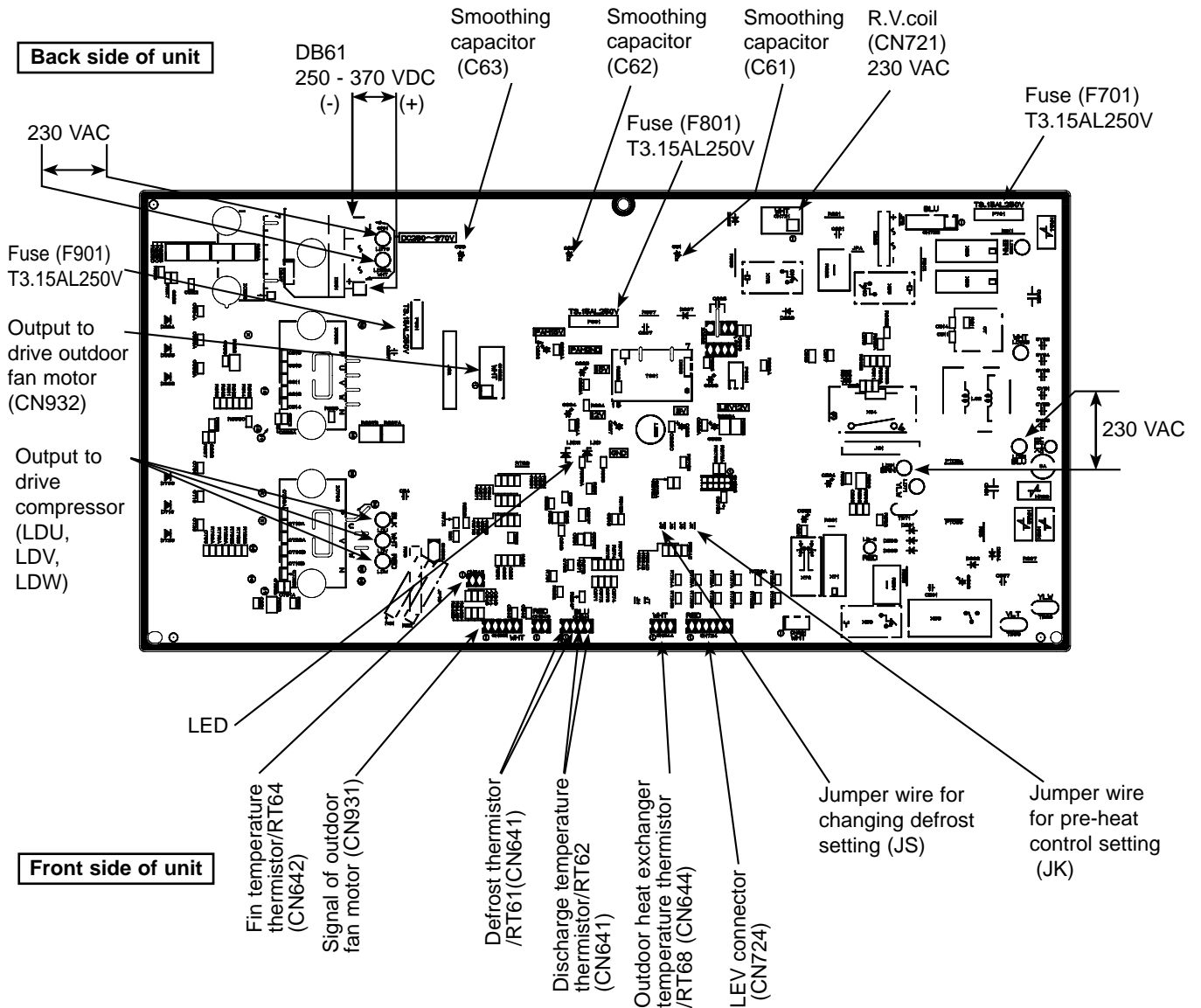

<"Terminal with locking mechanism" Detaching points>

The terminal which has the locking mechanism can be detached as shown below. There are two types (refer to (1) and (2)) of the terminal with locking mechanism. The terminal without locking mechanism can be detached by pulling it out. Check the shape of the terminal before detaching.

(1) Slide the sleeve and check if there is a locking lever or not.

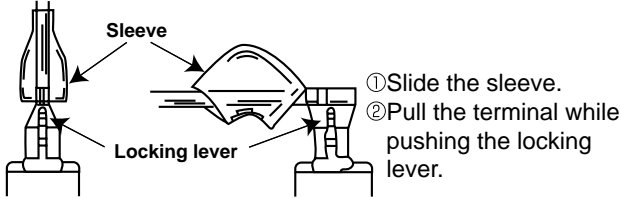

(2) The terminal with this connector has the locking mechanism.

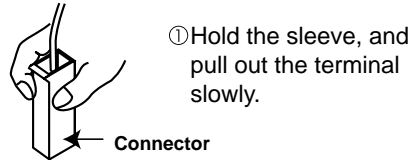

**12-1. MUZ-HJ25VA MUZ-HJ35VA**

**NOTE:** Turn OFF power supply before disassembly.

OPERATING PROCEDURE	PHOTOS
<p><b>1. Removing the cabinet and the panels</b></p> <ol style="list-style-type: none"> <li>(1) Remove the screw fixing the service panel.</li> <li>(2) Pull down the service panel and remove it.</li> <li>(3) Disconnect the power supply and indoor/outdoor connecting wire.</li> <li>(4) Remove the screws fixing the top panel.</li> <li>(5) Remove the top panel.</li> <li>(6) Remove the screws fixing the cabinet.</li> <li>(7) Remove the cabinet.</li> <li>(8) Remove the fixing screws of the terminal block support and the back panel. (Photo 4)</li> <li>(9) Remove the screws fixing the back panel.</li> <li>(10) Remove the back panel.</li> </ol> <p><b>Photo 2</b></p> <p>Screws of the top panel</p> <p>Direction to remove</p> <p>Screws of the service panel</p> <p>Hooks</p> <p>Screw of the cabinet</p>	<p><b>Photo 1</b></p> <p>Screws of the top panel</p> <p>Screws of the cabinet</p> <p><b>Photo 3</b></p> <p>Screws of the back panel</p>

## OPERATING PROCEDURE

### 2. Removing the inverter assembly, inverter P.C. board

- (1) Remove the cabinet and the panels. (Refer to 1.)
- (2) Disconnect the lead wire to the reactor and the following connectors:  
<Inverter P.C. board>  
CN721 (R.V. coil)  
CN771 (Fan motor)  
CN641 (Defrost thermistor and discharge temperature thermistor)  
CN724 (LEV)
- (3) Remove the compressor connector (CN61).
- (4) Remove the screws fixing the heat sink support and the separator.
- (5) Remove the inverter assembly.
- (6) Remove the screw of the earth wire and the screw of the terminal block support.
- (7) Remove the screw of the terminal block and remove the terminal block.
- (8) Remove the heat sink support from the P.C. board support.
- (9) Unhook the catch of the inverter P.C. board and remove the inverter P.C. board from the P.C. board support.

### 3. Removing the R.V. coil

- (1) Remove the cabinet and the panels. (Refer to 1.)
- (2) Disconnect the following connectors:  
<Inverter P.C. board>  
CN721 (R.V. coil)
- (3) Remove the R.V. coil.

## PHOTOS

Photo 4

Screw of the heat sink and the separator

Screws of the terminal block support and the back panel

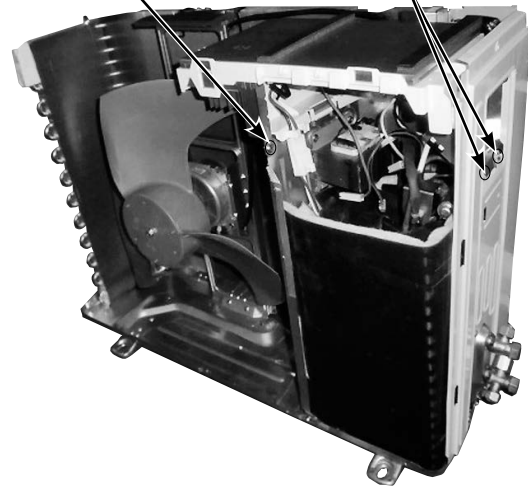
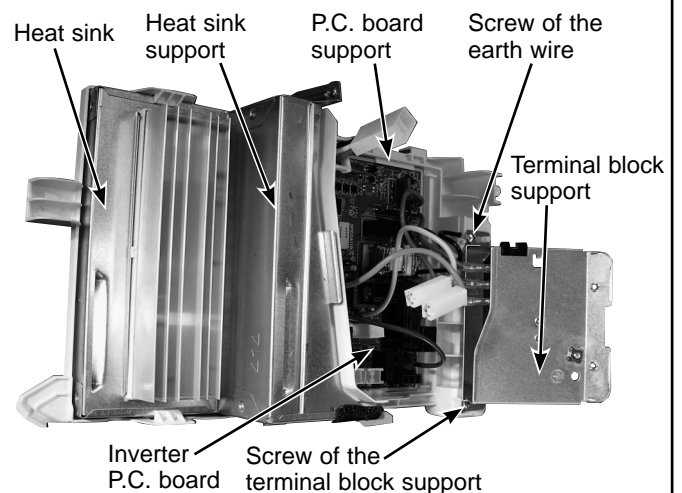

Photo 5 (Inverter assembly)



## OPERATING PROCEDURE

### 4. Removing the discharge temperature thermistor and the defrost thermistor

- (1) Remove the cabinet and the panels. (Refer to 1.)
- (2) Disconnect the lead wire to the reactor and the following connectors:  
<Inverter P.C. board>  
CN641 (Defrost thermistor and discharge temperature thermistor)
- (3) Pull out the discharge temperature thermistor from its holder.
- (4) Pull out the defrost thermistor from its holder.

### 5. Removing the outdoor fan motor

- (1) Remove the cabinet and the panels. (Refer to 1.)
- (2) Disconnect the following connectors:  
<Inverter P.C. board>  
CN771 (Fan motor)
- (3) Remove the fan motor lead wire from where it is fastened on the separator.
- (4) Remove the propeller nut.
- (5) Remove the propeller.
- (6) Remove the screws fixing the fan motor.
- (7) Remove the fan motor.

### 6. Removing the compressor and the 4-way valve

- (1) Remove the cabinet and the panels. (Refer to 1.)
- (2) Remove the inverter assembly. (Refer to 2.)
- (3) Remove the screws of the reactor and remove the reactor.
- (4) Remove the screws of the separator and remove the separator.
- (5) Remove the soundproof felt.
- (6) Remove the terminal cover and the compressor lead wire.
- (7) Recover gas from the refrigerant circuit.  
**NOTE:** Recover gas from the pipes until the pressure gauge shows 0 kg/cm<sup>2</sup> (0 MPa).
- (8) Detach the brazed part of the suction and the discharge pipe connected with the compressor.
- (9) Detach the brazed part of pipes connected with the 4-way valve.
- (10) Remove the nuts of compressor legs.
- (11) Remove the compressor.

## PHOTOS

Photo 6

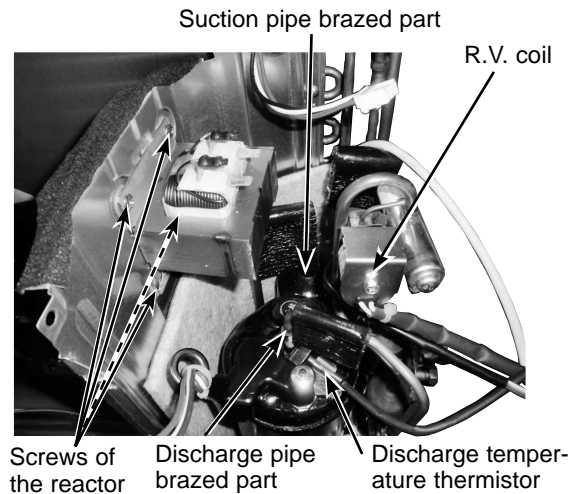

Photo 7

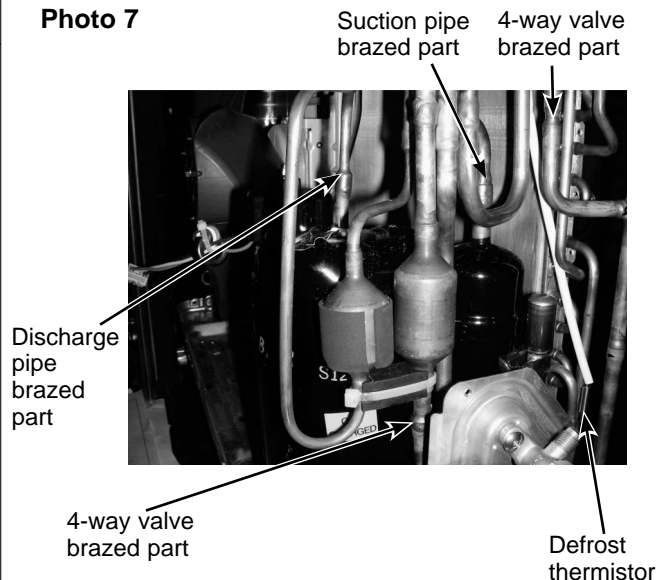
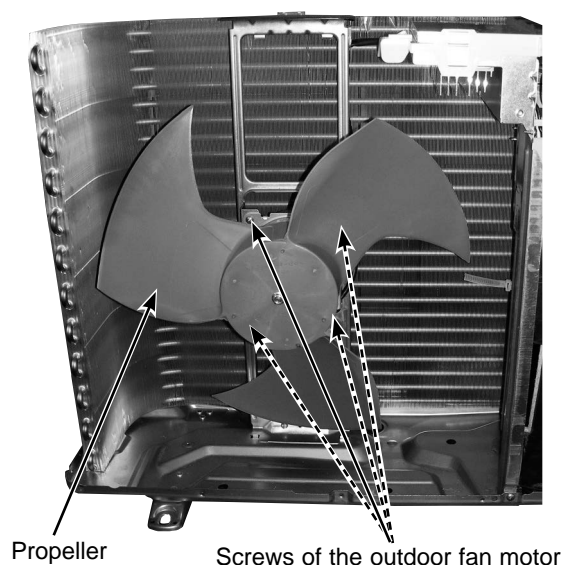
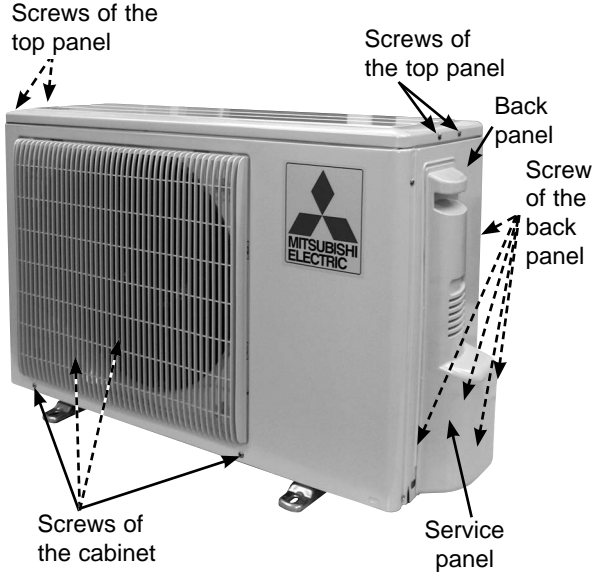
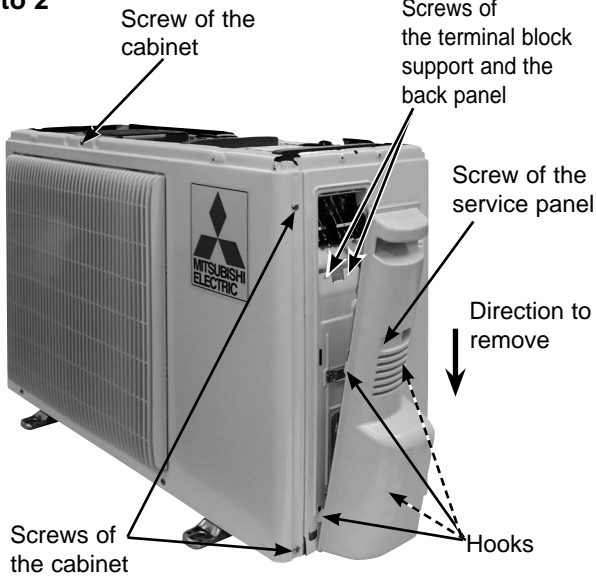

Photo 8



## 12-2. MUZ-HJ50VA

**NOTE:** Turn OFF power supply before disassembly.

OPERATING PROCEDURE	PHOTOS
<p><b>1. Removing the cabinet and the panels</b></p> <ol style="list-style-type: none"><li>(1) Remove the screw fixing the service panel.</li><li>(2) Pull down the service panel and remove it.</li><li>(3) Disconnect the power supply and indoor/outdoor connecting wire.</li><li>(4) Remove the screws fixing the top panel.</li><li>(5) Remove the top panel.</li><li>(6) Remove the screws fixing the cabinet.</li><li>(7) Remove the cabinet.</li><li>(8) Remove the fixing screws of the terminal block support and the back panel.</li><li>(9) Remove the screws fixing the back panel.</li><li>(10) Remove the back panel.</li></ol>	<p><b>Photo 1</b></p>  <p><b>Photo 2</b></p> 

## OPERATING PROCEDURE

### 2. Removing the inverter assembly, inverter P.C. board

- (1) Remove the cabinet and the panels. (Refer to 1.)
- (2) Disconnect the lead wire to the reactor and the following connectors:  
<Inverter P.C. board>  
CN721 (R.V. coil)  
CN931, CN932 (Fan motor)  
CN641 (Defrost thermistor and discharge temperature thermistor)  
CN644 (Outdoor heat exchanger temperature thermistor)  
CN724 (LEV)
- (3) Remove the compressor connector (CN61).
- (4) Remove the screws fixing the heat sink support and the separator.
- (5) Remove the inverter assembly.
- (6) Remove the screw of the earth wire and the screw of the terminal block support.
- (7) Remove the screw of the terminal block and remove the terminal block.
- (8) Remove the heat sink support from the P.C. board support.
- (9) Remove the screw of the inverter P.C. board and remove the inverter P.C. board from the P.C. board support.

### 3. Removing the R.V. coil

- (1) Remove the cabinet and the panels. (Refer to 1.)
- (2) Disconnect the following connectors:  
<Inverter P.C. board>  
CN721 (R.V. coil)
- (3) Remove the R.V. coil.

### 4. Removing the discharge temperature thermistor, defrost thermistor and outdoor heat exchanger temperature thermistor

- (1) Remove the cabinet and the panels. (Refer to 1.)
- (2) Disconnect the lead wire to the reactor and the following connectors:  
<Inverter P.C. board>  
CN641 (Defrost thermistor and discharge temperature thermistor)  
CN644 (Outdoor heat exchanger temperature thermistor)
- (3) Pull out the discharge temperature thermistor from its holder.
- (4) Pull out the defrost thermistor from its holder. (Photo 6)
- (5) Pull out the outdoor heat exchanger temperature thermistor from its holder. (Photo 6)

## PHOTOS

Photo 3

Screws of the heat sink support and the separator      Screws of the terminal block support and the back panel

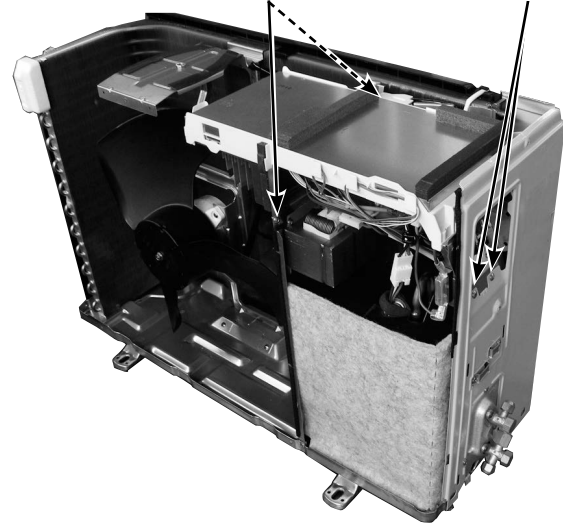

Photo 4 (Inverter assembly)

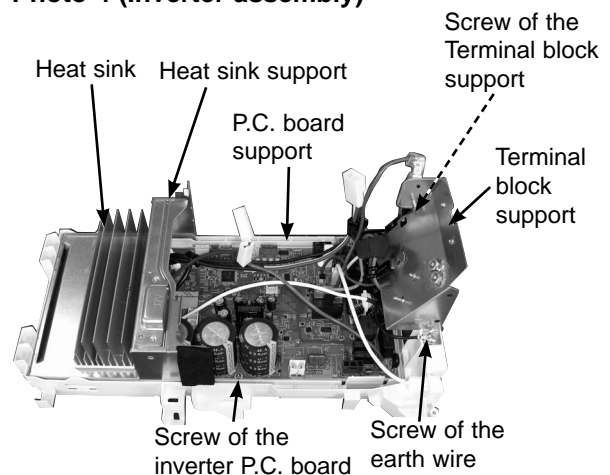

Photo 5



Discharge temperature thermistor

## OPERATING PROCEDURE

### 5. Removing the outdoor fan motor

- (1) Remove the cabinet and the panels. (Refer to 1.)
- (2) Disconnect the following connectors:  
<Inverter P.C. board>  
CN931, CN932 (Fan motor)
- (3) Remove the fan motor lead wire from where it is fastened on the separator.
- (4) Remove the propeller nut.
- (5) Remove the propeller.
- (6) Remove the screws fixing the fan motor.
- (7) Remove the fan motor.

### 6. Removing the compressor and the 4-way valve

- (1) Remove the cabinet and the panels. (Refer to 1.)
- (2) Remove the inverter assembly. (Refer to 2.)
- (3) Remove the screws of the reactor and remove the reactor.
- (4) Remove the screws of the separator and remove the separator.
- (5) Remove the soundproof felt.
- (6) Remove the terminal cover and the compressor lead wire.
- (7) Recover gas from the refrigerant circuit.  
**NOTE:** Recover gas from the pipes until the pressure gauge shows 0 kg/cm<sup>2</sup> (0 MPa).
- (8) Detach the brazed part of the suction and the discharge pipe connected with the compressor.
- (9) Detach the brazed part of pipes connected with the 4-way valve.
- (10) Remove the nuts of compressor legs.
- (11) Remove the compressor.

Photo 8

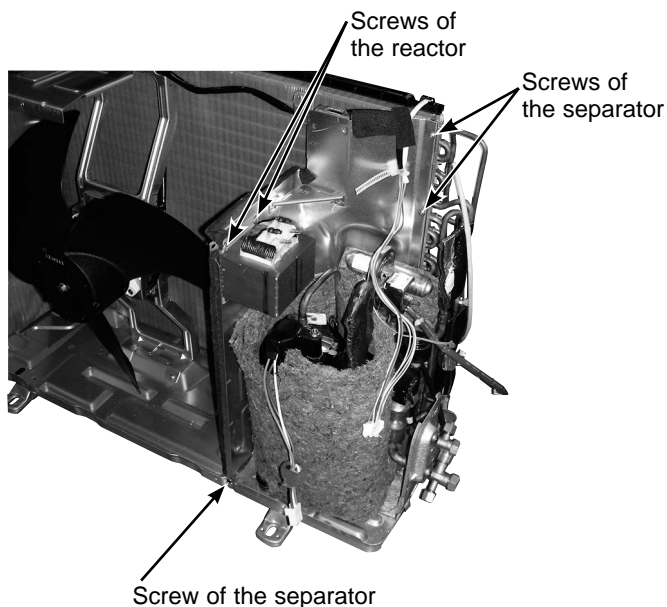

## PHOTOS

Photo 6

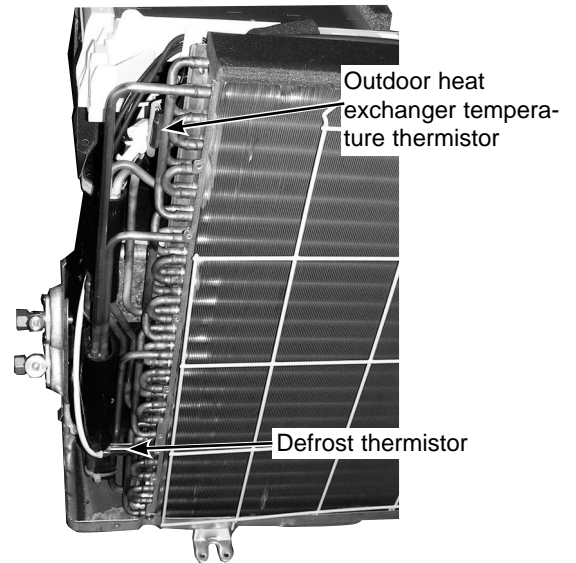

Photo 7

Screws of the outdoor fan motor

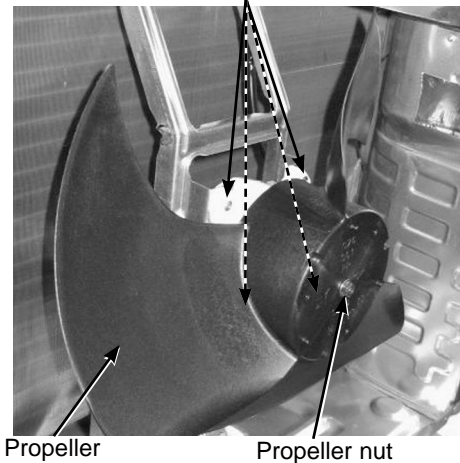
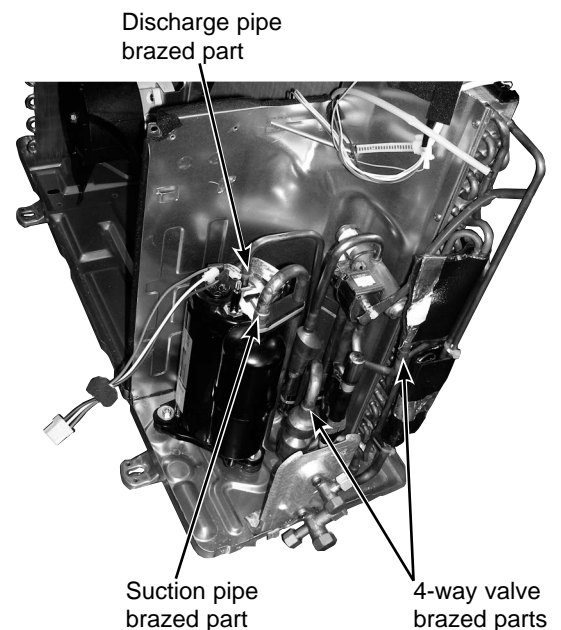

Photo 9



# **mitsubishi electric corporation**

HEAD OFFICE: TOKYO BLDG., 2-7-3, MARUNOUCHI, CHIYODA-KU, TOKYO 100-8310, JAPAN

© Copyright 2012 MITSUBISHI ELECTRIC CORPORATION  
Distributed in Mar. 2013. No. OBH648 REVISED EDITION-A  
Distributed in Dec. 2012. No. OBH648  
Made in Japan

New publication, effective Mar. 2013  
Specifications are subject to change without notice.