



SPLIT-TYPE AIR CONDITIONERS

## OUTDOOR UNIT

# SERVICE MANUAL



No. OBH751

### Models

**MUZ-DM25VA** - **E1**, **ER1**, **ET1**

**MUZ-DM35VA** - **E1**, **ER1**, **ET1**

Indoor unit service manual  
MSZ-DM•VA Series (OBH750)

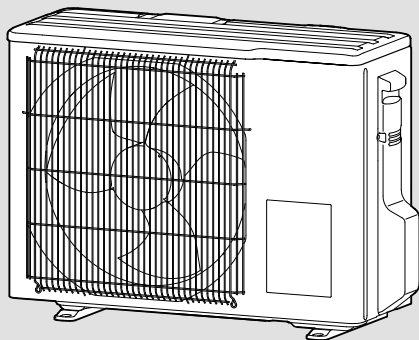

### CONTENTS

1. TECHNICAL CHANGES .....	2
2. PART NAMES AND FUNCTIONS .....	3
3. SPECIFICATION .....	4
4. NOISE CRITERIA CURVES .....	6
5. OUTLINES AND DIMENSIONS .....	7
6. WIRING DIAGRAM .....	8
7. REFRIGERANT SYSTEM DIAGRAM .....	9
8. PERFORMANCE CURVES .....	10
9. ACTUATOR CONTROL .....	20
10. SERVICE FUNCTIONS .....	21
11. TROUBLESHOOTING .....	22
12. DISASSEMBLY INSTRUCTIONS .....	40

**PARTS CATALOG (OBB751)**

**NOTE:**  
RoHS compliant products have <G> mark on the spec name plate.

## Use the specified refrigerant only

### Never use any refrigerant other than that specified.

Doing so may cause a burst, an explosion, or fire when the unit is being used, serviced, or disposed of.

Correct refrigerant is specified in the manuals and on the spec labels provided with our products.

We will not be held responsible for mechanical failure, system malfunction, unit breakdown or accidents caused by failure to follow the instructions.

#### <Preparation before the repair service>

- Prepare the proper tools.
- Prepare the proper protectors.
- Provide adequate ventilation.
- After stopping the operation of the air conditioner, turn off the power-supply breaker and remove the power plug.
- Discharge the capacitor before the work involving the electric parts.

#### <Precautions during the repair service>

- Do not perform the work involving the electric parts with wet hands.
- Do not pour water into the electric parts.
- Do not touch the refrigerant.
- Do not touch the hot or cold areas in the refrigeration cycle.
- When the repair or the inspection of the circuit needs to be done without turning off the power, exercise great caution not to touch the live parts.

## 1

## TECHNICAL CHANGES

**MUZ-DM25VA** -E1, ER1, ET1

**MUZ-DM35VA** -E1, ER1, ET1

1. New model

## 2

# PART NAMES AND FUNCTIONS

MUZ-DM25VA MUZ-DM35VA

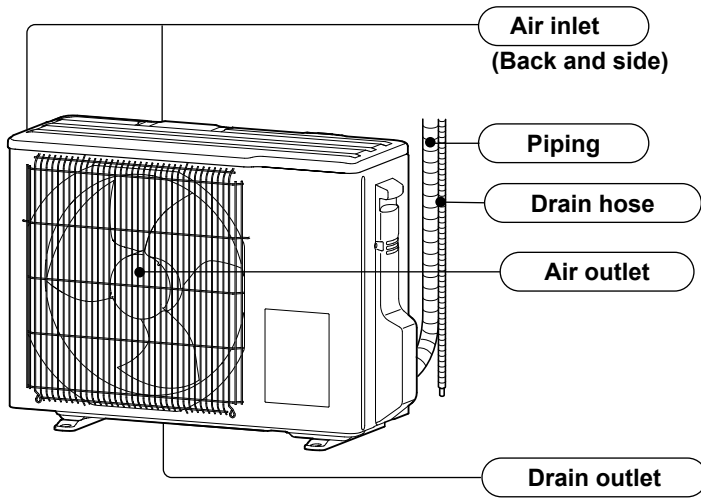

### ACCESSORIES

①	Drain socket	1
---	--------------	---

# 3

# SPECIFICATION

Outdoor model			MUZ-DM25VA	MUZ-DM35VA		
Power supply			Single phase, 230 V, 50 Hz			
Capacity Rated frequency (Min.-Max.)	Cooling	kW	2.5 (1.3 - 3.0)	3.15 (1.4 - 3.5)		
	Heating		3.15 (0.9 - 3.5)	3.6 (1.1 - 4.1)		
Breaker Capacity		A	10			
Electrical data	Power input *1 (Set)	Cooling	710	1,020		
		Heating	850	975		
	Running current *1 (Set)	Cooling	3.6	4.8		
		Heating	4.1	4.7		
	Power factor *1 (Set)	Cooling	85	92		
		Heating	90			
Starting current *1 (Set)		A	4.1	4.8		
Coeff. of performance (COP) *1 (Set)		Cooling	3.52	3.09		
		Heating	3.71	3.69		
Compressor		Model		KNB065FUBMC	KNB073FUXMC	
		Output		W	500	550
		Current *1	Cooling	A	3.3	4.4
			Heating	A	3.8	4.4
Refrigeration oil (Model)		L	0.27 (FV50S)			
Fan motor		Model		RC0J20-AA		
		Current *1		A	0.26	
Dimensions W × H × D			mm		699 × 538 × 249	
Weight			kg	24	25	
Special remarks	Dehumidification	Cooling	L/h	0.4	0.6	
	Air flow *1		m <sup>3</sup> /h	1,890		
	Sound level *1	Cooling	dB(A)	50	51	
		Heating		50	51	
	Fan speed		rpm	840		
	Fan speed regulator			1		
Refrigerant filling capacity (R410A)		kg	0.70	0.72		

**NOTE:** Test conditions are based on ISO 5151.

Cooling: Indoor Dry-bulb temperature 27°C  
 Outdoor Dry-bulb temperature 35°C  
 Heating: Indoor Dry-bulb temperature 20°C  
 Outdoor Dry-bulb temperature 7°C

Wet-bulb temperature 19°C

Wet-bulb temperature 6°C

Refrigerant piping length (one way): 5 m

\*1 Measured under rated operating frequency.



**Specifications and rated conditions of main electric parts**

Item	Model	MUZ-DM25VA	MUZ-DM35VA
Smoothing capacitor	(C62)	800 $\mu$ F 420 V	
Diode module	(DB61)	15 A 600 V	
	(DB65)	25 A 600 V	
Fuse	(F701, F801, F901)	T3.15AL250V	
Power module	(IC700)	10 A 600 V	
Expansion valve coil	(LEV)	12 VDC	
Reactor	(L61)	18 mH	
Switching power transistor	(Q821)	30 A 600 V	
Circuit protection	(PTC65)	33 $\Omega$	
Terminal block	(TB)	3 P	
Relay	(X63)	3 A 250 V	
	(X64)	20 A 250 V	
R.V. coil	(21S4)	220 - 240 VAC	

# 4

# NOISE CRITERIA CURVES

## MUZ-DM25VA

FUNCTION	SPL(dB(A))	LINE
COOLING	50	●—●
HEATING	50	○—○

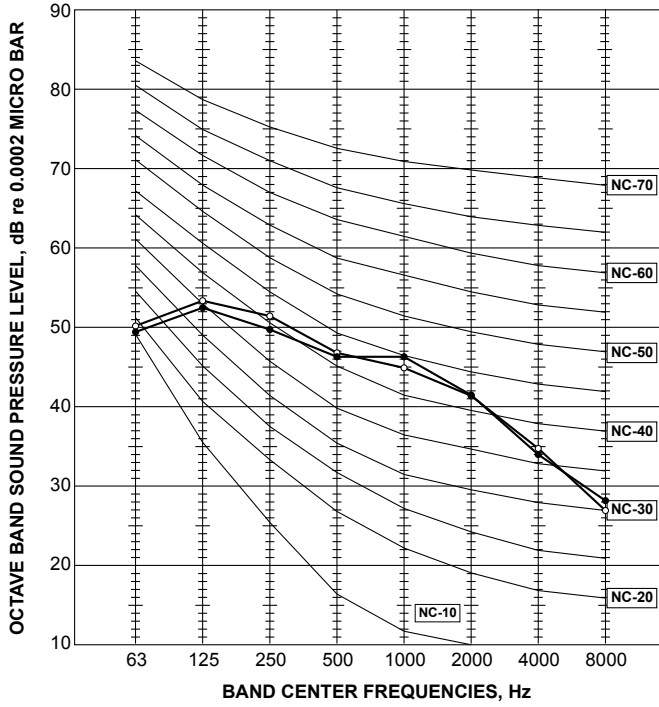

## MUZ-DM35VA

FUNCTION	SPL(dB(A))	LINE
COOLING	51	●—●
HEATING	51	○—○

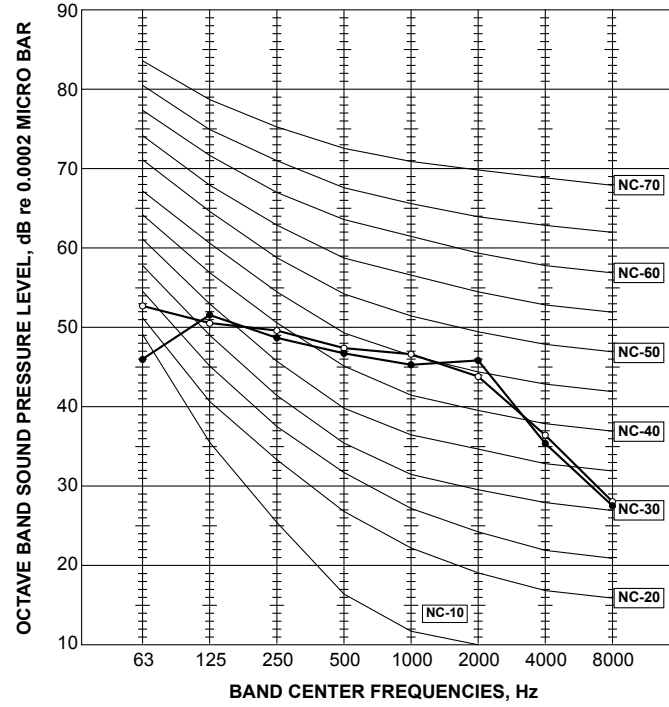

### Test conditions

Cooling : Dry-bulb temperature 35°C

Heating : Dry-bulb temperature 7°C Wet-bulb temperature 6°C

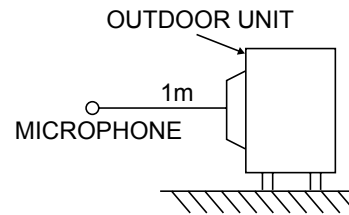

# 5

# OUTLINES AND DIMENSIONS

MUZ-DM25VA MUZ-DM35VA

Unit : mm

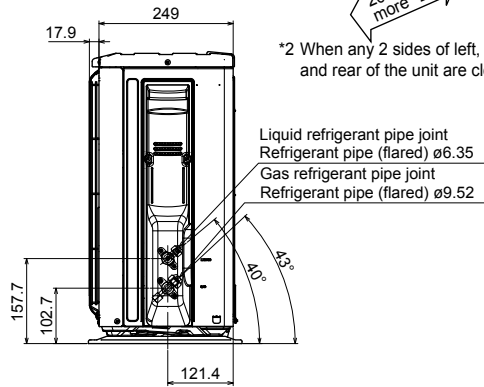
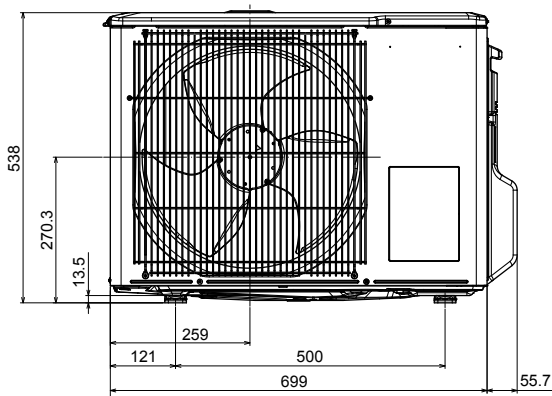
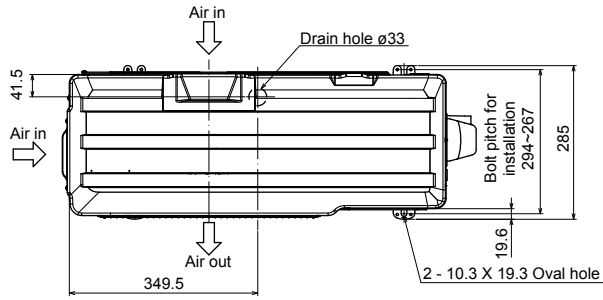

### REQUIRED SPACE

\*1 100 mm or more when front and sides of the unit are clear

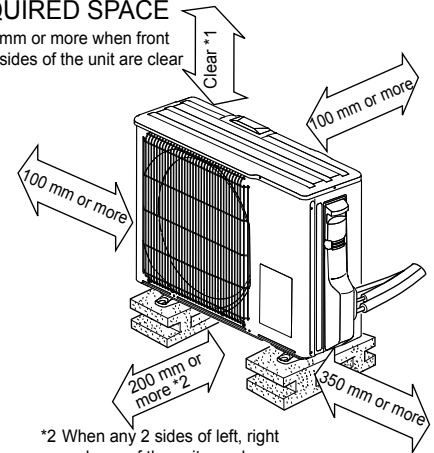



\*2 When any 2 sides of left, right and rear of the unit are clear

# 6

# WIRING DIAGRAM

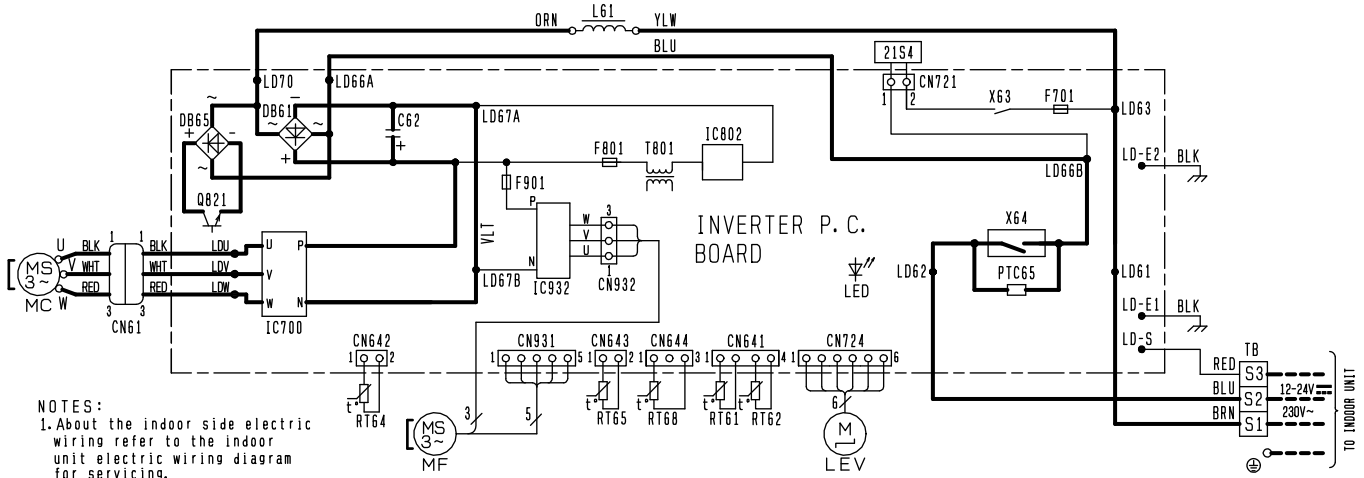
**MUZ-DM25VA**  
**MUZ-DM35VA**



- NOTES:**
- About the indoor side electric wiring refer to the indoor unit electric wiring diagram for servicing.
  - Use copper supply wires.
  - Symbols indicate, :Terminal block  
:Connector

SYMBOL	NAME	SYMBOL	NAME	SYMBOL	NAME
CN61	CONNECTOR	L61	REACTOR	RT65	AMBIENT TEMP. THERMISTOR
C62	SMOOTHING CAPACITOR	MC	COMPRESSOR	RT68	OUTDOOR HEAT EXCHANGER TEMP. THERMISTOR
DB61, DB65	DIODE MODULE	MF	FAN MOTOR	TB	TERMINAL BLOCK
F701, F801, F901	FUSE (T3, 15A/250V)	PTC65	CIRCUIT PROTECTION	T801	TRANSFORMER
IC700, IC932	POWER MODULE	Q821	SWITCHING POWER TRANSISTOR	X63, X64	RELAY
IC802	POWER DEVICE	RT61	DEFROST THERMISTOR	21S4	REVERSING VALVE COIL
LED	LED	RT62	DISCHARGE TEMP. THERMISTOR		
LEV	EXPANSION VALVE COIL	RT64	FIN TEMP. THERMISTOR		



# 7

# REFRIGERANT SYSTEM DIAGRAM

MUZ-DM25VA MUZ-DM35VA

Unit : mm

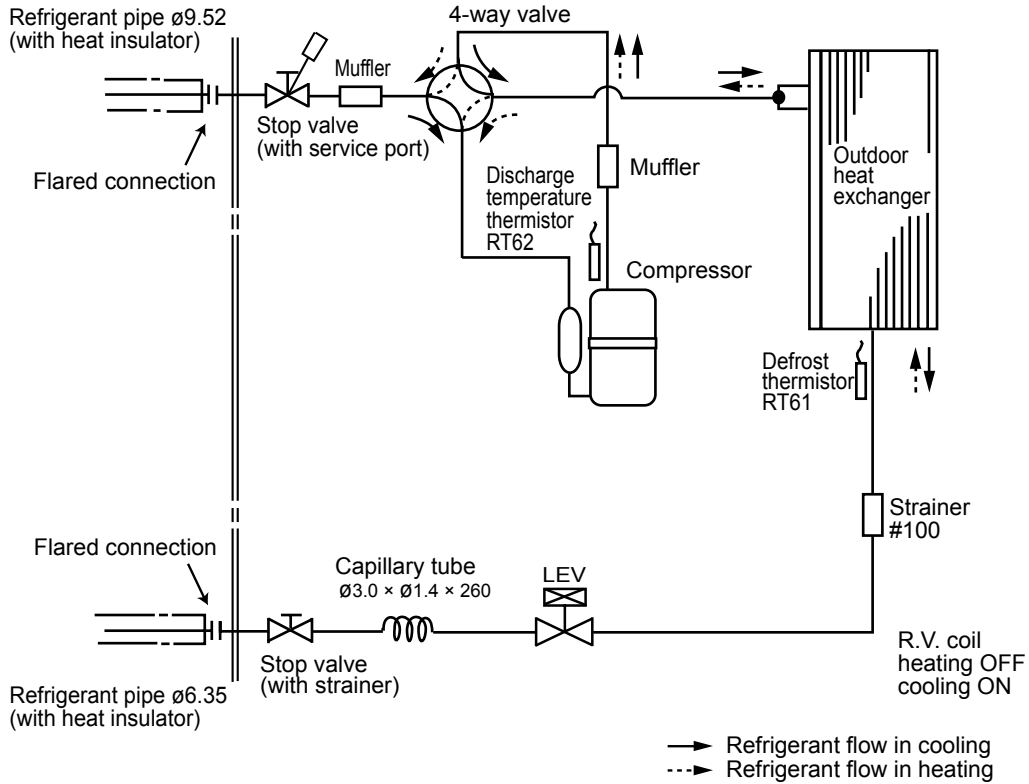

## MAX. REFRIGERANT PIPING LENGTH and MAX. HEIGHT DIFFERENCE

Model	Refrigerant piping: m		Piping size O.D: mm	
	Max. Length A	Max. Height difference B	Gas	Liquid
MUZ-DM25VA MUZ-DM35VA	20	12	9.52	6.35

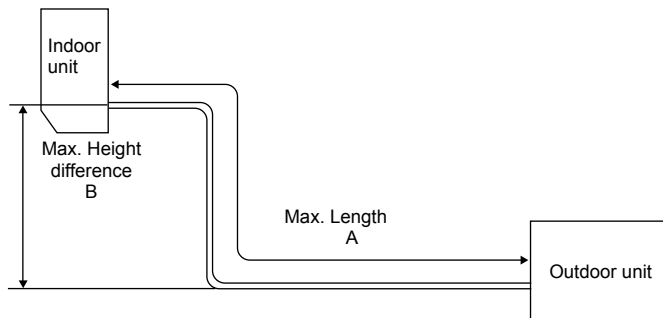

## ADDITIONAL REFRIGERANT CHARGE (R410A : g)

Model	Outdoor unit precharged	Refrigerant piping length (one way)											
		5 m	6 m	7 m	8 m	9 m	10 m	11 m	12 m	13 m	14 m	15 m	20 m
MUZ-DM25VA	700	0	0	0	20	40	60	80	100	120	140	160	260
MUZ-DM35VA	720	0	0	0	20	40	60	80	100	120	140	160	260

Calculation:  $X \text{ g} = 20 \text{ g/m} \times (\text{Refrigerant piping length (m)} - 7)$

**NOTE :** Refrigerant piping exceeding 7 m requires additional refrigerant charge according to the calculation.

**MUZ-DM25VA MUZ-DM35VA**

The standard specifications apply only to the operation of the air conditioner under normal conditions. Since operating conditions vary according to the areas where these units are installed, the following information has been provided to clarify the operating characteristics of the air conditioner under the conditions indicated by the performance curve.

**(1) GUARANTEED VOLTAGE**

198 ~ 264 V, 50 Hz

**(2) AIR FLOW**

Air flow should be set at MAX.

**(3) MAIN READINGS**

(1) Indoor intake air wet-bulb temperature :	°C WB	} Cooling
(2) Indoor outlet air wet-bulb temperature :	°C WB	
(3) Outdoor intake air dry-bulb temperature :	°C DB	
(4) Total input:	W	} Heating
(5) Indoor intake air dry-bulb temperature :	°C DB	
(6) Outdoor intake air wet-bulb temperature :	°C WB	
(7) Total input :	W	

Indoor air wet and dry bulb temperature difference on the left side of the following chart shows the difference between the indoor intake air wet and dry bulb temperature and the indoor outlet air wet and dry bulb temperature for your reference at service.

**How to measure the indoor air wet and dry bulb temperature difference**

1. Attach at least 2 sets of wet and dry bulb thermometers to the indoor air intake as shown in the figure, and at least 2 sets of wet and dry bulb thermometers to the indoor air outlet. The thermometers must be attached to the position where air speed is high.
2. Attach at least 2 sets of wet and dry bulb thermometers to the outdoor air intake.  
Cover the thermometers to prevent direct rays of the sun.
3. Check that the air filter is cleaned.
4. Open windows and doors of room.
5. Press the EMERGENCY OPERATION switch once (twice) to start the EMERGENCY COOL (HEAT) MODE.
6. When system stabilizes after more than 15 minutes, measure temperature and take an average temperature.
7. 10 minutes later, measure temperature again and check that the temperature does not change.

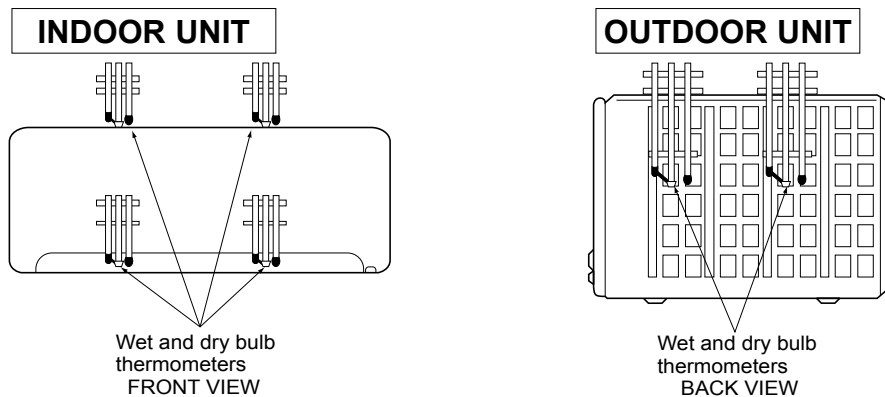

## 8-1. CAPACITY AND INPUT CURVES

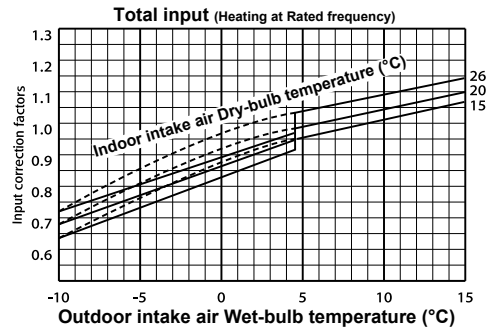
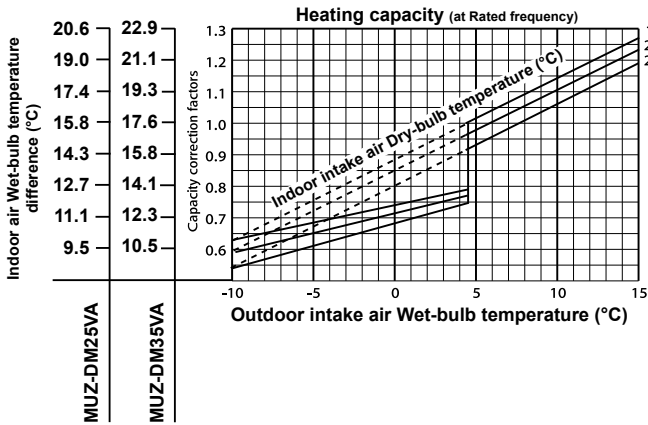
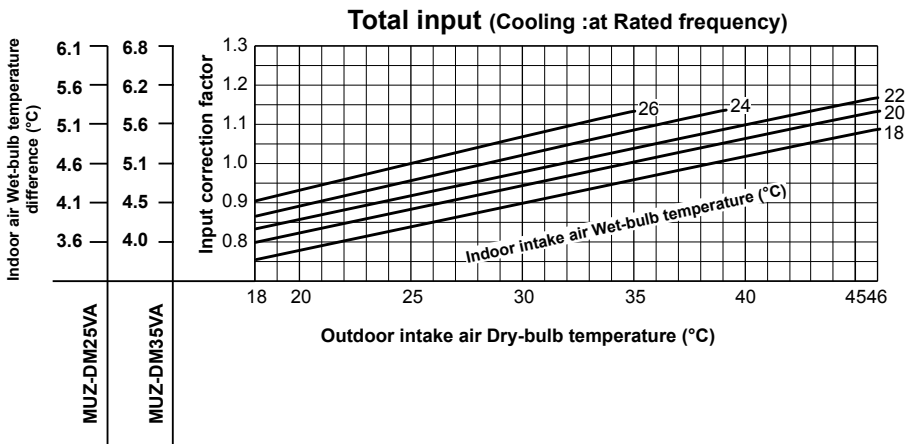
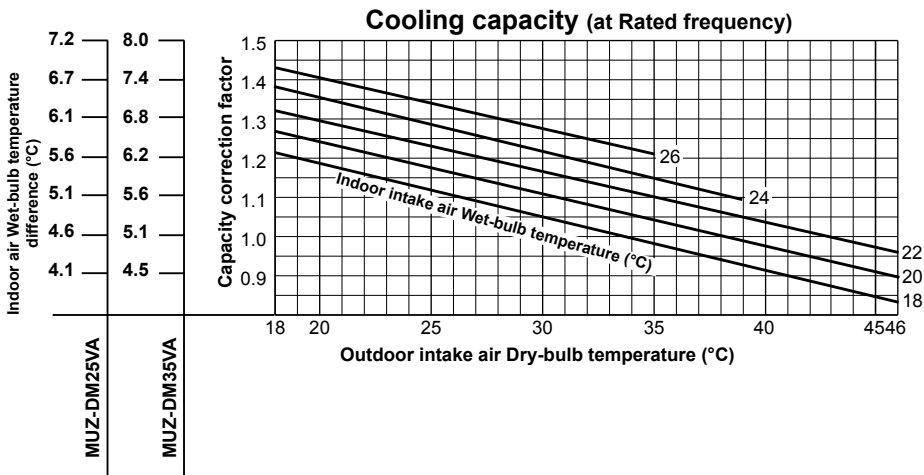

**NOTE:** The above broken lines are for the heating operation without any frost and defrost operation.

## 8-2. CAPACITY AND INPUT CORRECTION BY OPERATIONAL FREQUENCY OF COMPRESSOR

### MUZ-DM25VA

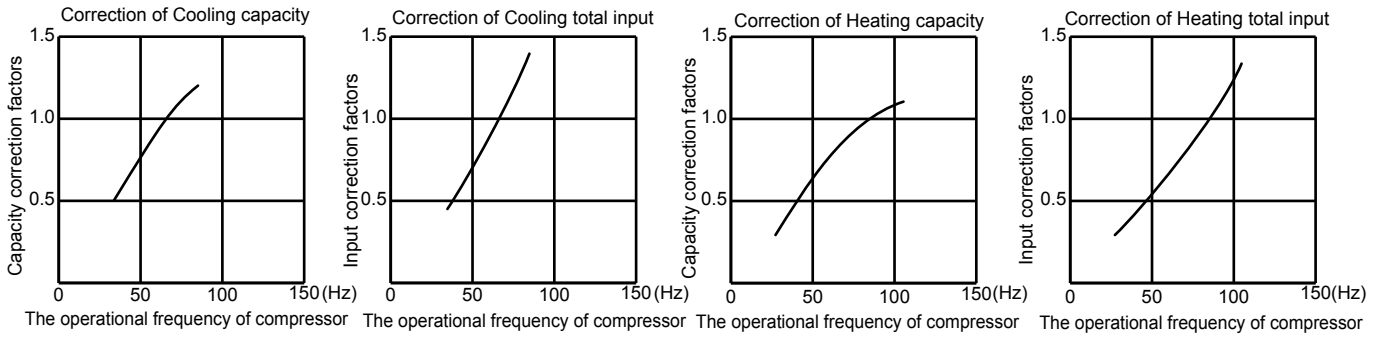

### MUZ-DM35VA

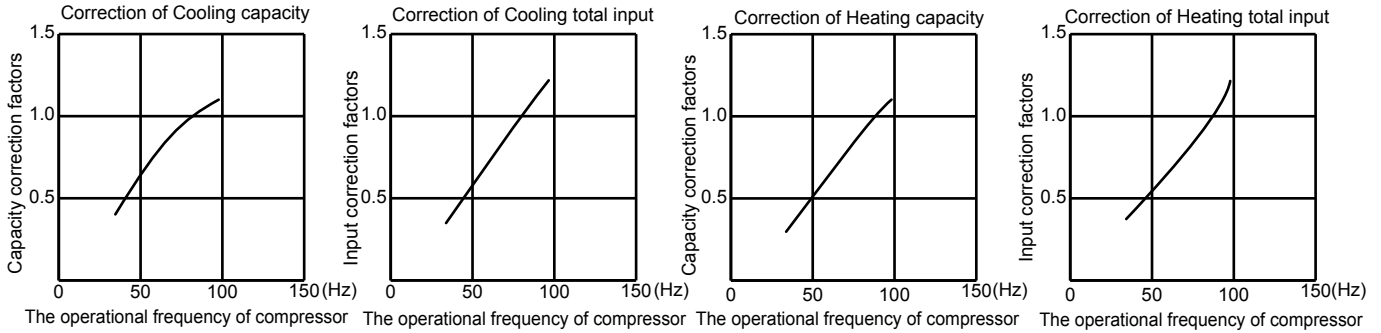

### 8-3. HOW TO OPERATE FIXED-FREQUENCY OPERATION

<Test run operation>

1. Press EMERGENCY OPERATION switch to start COOL or HEAT mode (COOL: Press once, HEAT: Press twice).
2. Test run operation starts and continues to operate for 30 minutes.
3. Compressor operates at rated frequency in COOL mode or 58 Hz in HEAT mode.
4. Indoor fan operates at High speed.
5. After 30 minutes, test run operation finishes and EMERGENCY OPERATION starts (operation frequency of compressor varies).
6. To cancel test run operation (EMERGENCY OPERATION), press EMERGENCY OPERATION switch or any button on remote controller.

### 8-4. OUTDOOR LOW PRESSURE AND OUTDOOR UNIT CURRENT

#### COOL operation

- ① Both indoor and outdoor unit are under the same temperature/humidity condition.
- ② Operation: TEST RUN OPERATION (Refer to 8-3.)

Dry-bulb temperature (°C)	Relative humidity (%)
20	50
25	60
30	70

#### Outdoor low pressure

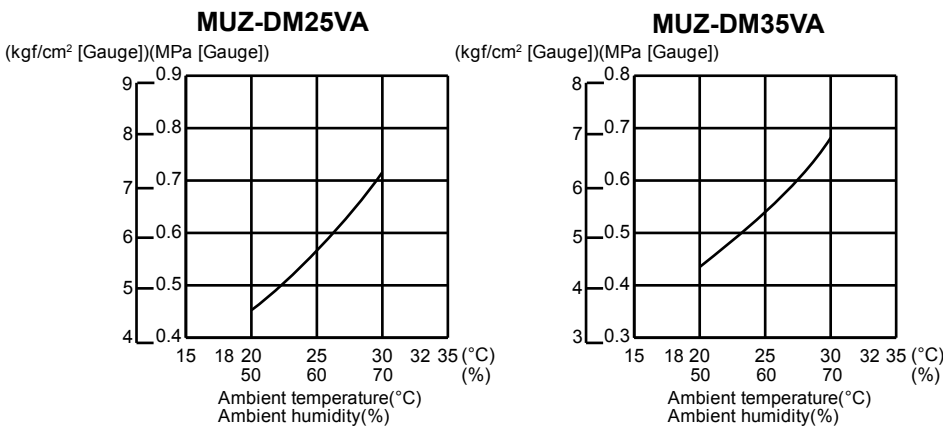

**NOTE :** The unit of pressure has been changed to MPa on the international system of units (SI unit system).  
The conversion factor is: **1 (MPa [Gauge]) = 10.2 (kgf/cm²[Gauge])**

#### Outdoor unit current

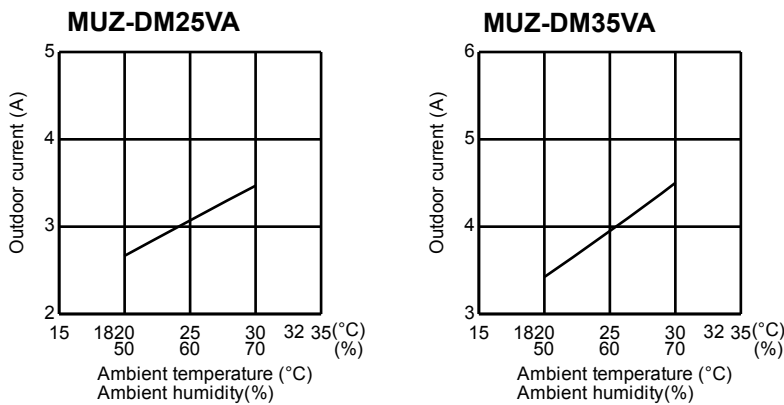

## HEAT operation

① Condition:

	Indoor	Outdoor			
Dry bulb temperature (°C)	20.0	2	7	15	20.0
Wet bulb temperature (°C)	14.5	1	6	12	14.5

② Operation: Test run operation (refer to 8-3.)

### Outdoor unit current

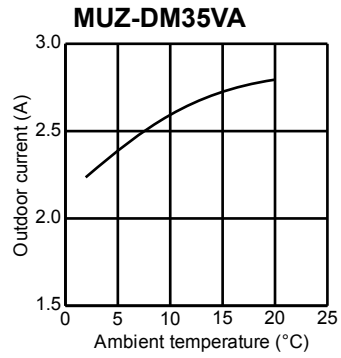
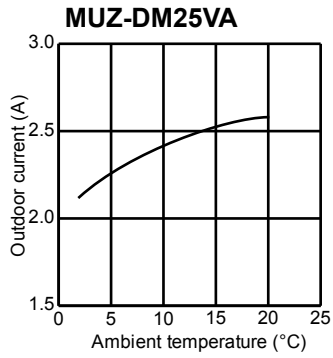

**PERFORMANCE DATA COOL operation at Rated frequency**

**MUZ-DM25VA**

CAPACITY: 2.5 kW

SHF: 0.89

INPUT: 710 W

INDOOR DB (°C)	INDOOR WB (°C)	OUTDOOR DB (°C)															
		21				25				27				30			
		Q	SHC	SHF	INPUT	Q	SHC	SHF	INPUT	Q	SHC	SHF	INPUT	Q	SHC	SHF	INPUT
21	18	2.94	2.09	0.71	568	2.81	2.00	0.71	596	2.70	1.92	0.71	625	2.60	1.85	0.71	653
21	20	3.06	1.81	0.59	596	2.94	1.73	0.59	632	2.85	1.68	0.59	646	2.75	1.62	0.59	675
22	18	2.94	2.20	0.75	568	2.81	2.11	0.75	596	2.70	2.03	0.75	625	2.60	1.95	0.75	653
22	20	3.06	1.93	0.63	596	2.94	1.85	0.63	632	2.85	1.80	0.63	646	2.75	1.73	0.63	675
22	22	3.19	1.63	0.51	618	3.08	1.57	0.51	657	3.00	1.53	0.51	675	2.88	1.47	0.51	703
23	18	2.94	2.32	0.79	568	2.81	2.22	0.79	596	2.70	2.13	0.79	625	2.60	2.05	0.79	653
23	20	3.06	2.05	0.67	596	2.94	1.97	0.67	632	2.85	1.91	0.67	646	2.75	1.84	0.67	675
23	22	3.19	1.75	0.55	618	3.08	1.69	0.55	657	3.00	1.65	0.55	675	2.88	1.58	0.55	703
24	18	2.94	2.44	0.83	568	2.81	2.33	0.83	596	2.70	2.24	0.83	625	2.60	2.16	0.83	653
24	20	3.06	2.17	0.71	596	2.94	2.09	0.71	632	2.85	2.02	0.71	646	2.75	1.95	0.71	675
24	22	3.19	1.88	0.59	618	3.08	1.81	0.59	657	3.00	1.77	0.59	675	2.88	1.70	0.59	703
24	24	3.35	1.57	0.47	646	3.23	1.52	0.47	682	3.15	1.48	0.47	703	3.05	1.43	0.47	738
25	18	2.94	2.56	0.87	568	2.81	2.45	0.87	596	2.70	2.35	0.87	625	2.60	2.26	0.87	653
25	20	3.06	2.30	0.75	596	2.94	2.20	0.75	632	2.85	2.14	0.75	646	2.75	2.06	0.75	675
25	22	3.19	2.01	0.63	618	3.08	1.94	0.63	657	3.00	1.89	0.63	675	2.88	1.81	0.63	703
25	24	3.35	1.71	0.51	646	3.23	1.64	0.51	682	3.15	1.61	0.51	703	3.05	1.56	0.51	738
26	18	2.94	2.67	0.91	568	2.81	2.56	0.91	596	2.70	2.46	0.91	625	2.60	2.37	0.91	653
26	20	3.06	2.42	0.79	596	2.94	2.32	0.79	632	2.85	2.25	0.79	646	2.75	2.17	0.79	675
26	22	3.19	2.14	0.67	618	3.08	2.06	0.67	657	3.00	2.01	0.67	675	2.88	1.93	0.67	703
26	24	3.35	1.84	0.55	646	3.23	1.77	0.55	682	3.15	1.73	0.55	703	3.05	1.68	0.55	738
26	26	3.45	1.48	0.43	682	3.35	1.44	0.43	717	3.30	1.42	0.43	738	3.20	1.38	0.43	760
27	18	2.94	2.79	0.95	568	2.81	2.67	0.95	596	2.70	2.57	0.95	625	2.60	2.47	0.95	653
27	20	3.06	2.54	0.83	596	2.94	2.44	0.83	632	2.85	2.37	0.83	646	2.75	2.28	0.83	675
27	22	3.19	2.26	0.71	618	3.08	2.18	0.71	657	3.00	2.13	0.71	675	2.88	2.04	0.71	703
27	24	3.35	1.98	0.59	646	3.23	1.90	0.59	682	3.15	1.86	0.59	703	3.05	1.80	0.59	738
27	26	3.45	1.62	0.47	682	3.35	1.57	0.47	717	3.30	1.55	0.47	738	3.20	1.50	0.47	760
28	18	2.94	2.91	0.99	568	2.81	2.78	0.99	596	2.70	2.67	0.99	625	2.60	2.57	0.99	653
28	20	3.06	2.66	0.87	596	2.94	2.56	0.87	632	2.85	2.48	0.87	646	2.75	2.39	0.87	675
28	22	3.19	2.39	0.75	618	3.08	2.31	0.75	657	3.00	2.25	0.75	675	2.88	2.16	0.75	703
28	24	3.35	2.11	0.63	646	3.23	2.03	0.63	682	3.15	1.98	0.63	703	3.05	1.92	0.63	738
28	26	3.45	1.76	0.51	682	3.35	1.71	0.51	717	3.30	1.68	0.51	738	3.20	1.63	0.51	760
29	18	2.94	2.94	1.00	568	2.81	2.81	1.00	596	2.70	2.70	1.00	625	2.60	2.60	1.00	653
29	20	3.06	2.79	0.91	596	2.94	2.67	0.91	632	2.85	2.59	0.91	646	2.75	2.50	0.91	675
29	22	3.19	2.52	0.79	618	3.08	2.43	0.79	657	3.00	2.37	0.79	675	2.88	2.27	0.79	703
29	24	3.35	2.24	0.67	646	3.23	2.16	0.67	682	3.15	2.11	0.67	703	3.05	2.04	0.67	738
29	26	3.45	1.90	0.55	682	3.35	1.84	0.55	717	3.30	1.82	0.55	738	3.20	1.76	0.55	760
30	18	2.94	2.94	1.00	568	2.81	2.81	1.00	596	2.70	2.70	1.00	625	2.60	2.60	1.00	653
30	20	3.06	2.91	0.95	596	2.94	2.79	0.95	632	2.85	2.71	0.95	646	2.75	2.61	0.95	675
30	22	3.19	2.65	0.83	618	3.08	2.55	0.83	657	3.00	2.49	0.83	675	2.88	2.39	0.83	703
30	24	3.35	2.38	0.71	646	3.23	2.29	0.71	682	3.15	2.24	0.71	703	3.05	2.17	0.71	738
30	26	3.45	2.04	0.59	682	3.35	1.98	0.59	717	3.30	1.95	0.59	738	3.20	1.89	0.59	760
31	18	2.94	2.94	1.00	568	2.81	2.81	1.00	596	2.70	2.70	1.00	625	2.60	2.60	1.00	653
31	20	3.06	3.03	0.99	596	2.94	2.91	0.99	632	2.85	2.82	0.99	646	2.75	2.72	0.99	675
31	22	3.19	2.77	0.87	618	3.08	2.68	0.87	657	3.00	2.61	0.87	675	2.88	2.50	0.87	703
31	24	3.35	2.51	0.75	646	3.23	2.42	0.75	682	3.15	2.36	0.75	703	3.05	2.29	0.75	738
31	26	3.45	2.17	0.63	682	3.35	2.11	0.63	717	3.30	2.08	0.63	738	3.20	2.02	0.63	760
32	18	2.94	2.94	1.00	568	2.81	2.81	1.00	596	2.70	2.70	1.00	625	2.60	2.60	1.00	653
32	20	3.06	3.06	1.00	596	2.94	2.94	1.00	632	2.85	2.85	1.00	646	2.75	2.75	1.00	675
32	22	3.19	2.90	0.91	618	3.08	2.80	0.91	657	3.00	2.73	0.91	675	2.88	2.62	0.91	703
32	24	3.35	2.65	0.79	646	3.23	2.55	0.79	682	3.15	2.49	0.79	703	3.05	2.41	0.79	738
32	26	3.45	2.31	0.67	682	3.35	2.24	0.67	717	3.30	2.21	0.67	738	3.20	2.14	0.67	760

**NOTE** Q : Total capacity (kW) SHF : Sensible heat factor DB : Dry-bulb temperature  
SHC : Sensible heat capacity (kW) INPUT : Total power input (W) WB : Wet-bulb temperature

**PERFORMANCE DATA COOL operation at Rated frequency**

**MUZ-DM25VA**

CAPACITY: 2.5 kW

SHF: 0.89

INPUT: 710 W

INDOOR DB (°C)	INDOOR WB (°C)	OUTDOOR DB (°C)											
		35				40				46			
		Q	SHC	SHF	INPUT	Q	SHC	SHF	INPUT	Q	SHC	SHF	INPUT
21	18	2.45	1.74	0.71	696	2.25	1.60	0.71	738	2.08	1.47	0.71	767
21	20	2.58	1.52	0.59	724	2.40	1.42	0.59	760	2.23	1.31	0.59	802
22	18	2.45	1.84	0.75	696	2.25	1.69	0.75	738	2.08	1.56	0.75	767
22	20	2.58	1.62	0.63	724	2.40	1.51	0.63	760	2.23	1.40	0.63	802
22	22	2.73	1.39	0.51	753	2.55	1.30	0.51	795	2.38	1.21	0.51	824
23	18	2.45	1.94	0.79	696	2.25	1.78	0.79	738	2.08	1.64	0.79	767
23	20	2.58	1.73	0.67	724	2.40	1.61	0.67	760	2.23	1.49	0.67	802
23	22	2.73	1.50	0.55	753	2.55	1.40	0.55	795	2.38	1.31	0.55	824
24	18	2.45	2.03	0.83	696	2.25	1.87	0.83	738	2.08	1.72	0.83	767
24	20	2.58	1.83	0.71	724	2.40	1.70	0.71	760	2.23	1.58	0.71	802
24	22	2.73	1.61	0.59	753	2.55	1.50	0.59	795	2.38	1.40	0.59	824
24	24	2.88	1.35	0.47	781	2.70	1.27	0.47	817	2.55	1.20	0.47	852
25	18	2.45	2.13	0.87	696	2.25	1.96	0.87	738	2.08	1.81	0.87	767
25	20	2.58	1.93	0.75	724	2.40	1.80	0.75	760	2.23	1.67	0.75	802
25	22	2.73	1.72	0.63	753	2.55	1.61	0.63	795	2.38	1.50	0.63	824
25	24	2.88	1.47	0.51	781	2.70	1.38	0.51	817	2.55	1.30	0.51	852
26	18	2.45	2.23	0.91	696	2.25	2.05	0.91	738	2.08	1.89	0.91	767
26	20	2.58	2.03	0.79	724	2.40	1.90	0.79	760	2.23	1.76	0.79	802
26	22	2.73	1.83	0.67	753	2.55	1.71	0.67	795	2.38	1.59	0.67	824
26	24	2.88	1.58	0.55	781	2.70	1.49	0.55	817	2.55	1.40	0.55	852
26	26	3.03	1.30	0.43	809	2.85	1.23	0.43	845	2.68	1.15	0.43	880
27	18	2.45	2.33	0.95	696	2.25	2.14	0.95	738	2.08	1.97	0.95	767
27	20	2.58	2.14	0.83	724	2.40	1.99	0.83	760	2.23	1.85	0.83	802
27	22	2.73	1.93	0.71	753	2.55	1.81	0.71	795	2.38	1.69	0.71	824
27	24	2.88	1.70	0.59	781	2.70	1.59	0.59	817	2.55	1.50	0.59	852
27	26	3.03	1.42	0.47	809	2.85	1.34	0.47	845	2.68	1.26	0.47	880
28	18	2.45	2.43	0.99	696	2.25	2.23	0.99	738	2.08	2.05	0.99	767
28	20	2.58	2.24	0.87	724	2.40	2.09	0.87	760	2.23	1.94	0.87	802
28	22	2.73	2.04	0.75	753	2.55	1.91	0.75	795	2.38	1.78	0.75	824
28	24	2.88	1.81	0.63	781	2.70	1.70	0.63	817	2.55	1.61	0.63	852
28	26	3.03	1.54	0.51	809	2.85	1.45	0.51	845	2.68	1.36	0.51	880
29	18	2.45	2.45	1.00	696	2.25	2.25	1.00	738	2.08	2.08	1.00	767
29	20	2.58	2.34	0.91	724	2.40	2.18	0.91	760	2.23	2.02	0.91	802
29	22	2.73	2.15	0.79	753	2.55	2.01	0.79	795	2.38	1.88	0.79	824
29	24	2.88	1.93	0.67	781	2.70	1.81	0.67	817	2.55	1.71	0.67	852
29	26	3.03	1.66	0.55	809	2.85	1.57	0.55	845	2.68	1.47	0.55	880
30	18	2.45	2.45	1.00	696	2.25	2.25	1.00	738	2.08	2.08	1.00	767
30	20	2.58	2.45	0.95	724	2.40	2.28	0.95	760	2.23	2.11	0.95	802
30	22	2.73	2.26	0.83	753	2.55	2.12	0.83	795	2.38	1.97	0.83	824
30	24	2.88	2.04	0.71	781	2.70	1.92	0.71	817	2.55	1.81	0.71	852
30	26	3.03	1.78	0.59	809	2.85	1.68	0.59	845	2.68	1.58	0.59	880
31	18	2.45	2.45	1.00	696	2.25	2.25	1.00	738	2.08	2.08	1.00	767
31	20	2.58	2.55	0.99	724	2.40	2.38	0.99	760	2.23	2.20	0.99	802
31	22	2.73	2.37	0.87	753	2.55	2.22	0.87	795	2.38	2.07	0.87	824
31	24	2.88	2.16	0.75	781	2.70	2.03	0.75	817	2.55	1.91	0.75	852
31	26	3.03	1.91	0.63	809	2.85	1.80	0.63	845	2.68	1.69	0.63	880
32	18	2.45	2.45	1.00	696	2.25	2.25	1.00	738	2.08	2.08	1.00	767
32	20	2.58	2.58	1.00	724	2.40	2.40	1.00	760	2.23	2.23	1.00	802
32	22	2.73	2.48	0.91	753	2.55	2.32	0.91	795	2.38	2.16	0.91	824
32	24	2.88	2.27	0.79	781	2.70	2.13	0.79	817	2.55	2.01	0.79	852
32	26	3.03	2.03	0.67	809	2.85	1.91	0.67	845	2.68	1.79	0.67	880

**NOTE** Q : Total capacity (kW) SHF : Sensible heat factor DB : Dry-bulb temperature  
 SHC : Sensible heat capacity (kW) INPUT : Total power input (W) WB : Wet-bulb temperature



PERFORMANCE DATA COOL operation at Rated frequency

MUZ-DM35VA

CAPACITY: 3.15 kW

SHF: 0.87

INPUT: 1020 W

INDOOR DB (°C)	INDOOR WB (°C)	OUTDOOR DB (°C)															
		21				25				27				30			
		Q	SHC	SHF	INPUT	Q	SHC	SHF	INPUT	Q	SHC	SHF	INPUT	Q	SHC	SHF	INPUT
21	18	3.70	2.55	0.69	816	3.54	2.45	0.69	857	3.40	2.35	0.69	898	3.28	2.26	0.69	938
21	20	3.86	2.20	0.57	857	3.70	2.11	0.57	908	3.59	2.05	0.57	928	3.47	1.98	0.57	969
22	18	3.70	2.70	0.73	816	3.54	2.59	0.73	857	3.40	2.48	0.73	898	3.28	2.39	0.73	938
22	20	3.86	2.35	0.61	857	3.70	2.26	0.61	908	3.59	2.19	0.61	928	3.47	2.11	0.61	969
22	22	4.02	1.97	0.49	887	3.87	1.90	0.49	944	3.78	1.85	0.49	969	3.62	1.78	0.49	1010
23	18	3.70	2.85	0.77	816	3.54	2.73	0.77	857	3.40	2.62	0.77	898	3.28	2.52	0.77	938
23	20	3.86	2.51	0.65	857	3.70	2.41	0.65	908	3.59	2.33	0.65	928	3.47	2.25	0.65	969
23	22	4.02	2.13	0.53	887	3.87	2.05	0.53	944	3.78	2.00	0.53	969	3.62	1.92	0.53	1010
24	18	3.70	3.00	0.81	816	3.54	2.87	0.81	857	3.40	2.76	0.81	898	3.28	2.65	0.81	938
24	20	3.86	2.66	0.69	857	3.70	2.55	0.69	908	3.59	2.48	0.69	928	3.47	2.39	0.69	969
24	22	4.02	2.29	0.57	887	3.87	2.21	0.57	944	3.78	2.15	0.57	969	3.62	2.06	0.57	1010
24	24	4.22	1.90	0.45	928	4.06	1.83	0.45	979	3.97	1.79	0.45	1010	3.84	1.73	0.45	1061
25	18	3.70	3.15	0.85	816	3.54	3.01	0.85	857	3.40	2.89	0.85	898	3.28	2.78	0.85	938
25	20	3.86	2.82	0.73	857	3.70	2.70	0.73	908	3.59	2.62	0.73	928	3.47	2.53	0.73	969
25	22	4.02	2.45	0.61	887	3.87	2.36	0.61	944	3.78	2.31	0.61	969	3.62	2.21	0.61	1010
25	24	4.22	2.07	0.49	928	4.06	1.99	0.49	979	3.97	1.94	0.49	1010	3.84	1.88	0.49	1061
26	18	3.70	3.29	0.89	816	3.54	3.15	0.89	857	3.40	3.03	0.89	898	3.28	2.92	0.89	938
26	20	3.86	2.97	0.77	857	3.70	2.85	0.77	908	3.59	2.77	0.77	928	3.47	2.67	0.77	969
26	22	4.02	2.61	0.65	887	3.87	2.52	0.65	944	3.78	2.46	0.65	969	3.62	2.35	0.65	1010
26	24	4.22	2.24	0.53	928	4.06	2.15	0.53	979	3.97	2.10	0.53	1010	3.84	2.04	0.53	1061
26	26	4.35	1.78	0.41	979	4.22	1.73	0.41	1030	4.16	1.70	0.41	1061	4.03	1.65	0.41	1091
27	18	3.70	3.44	0.93	816	3.54	3.30	0.93	857	3.40	3.16	0.93	898	3.28	3.05	0.93	938
27	20	3.86	3.13	0.81	857	3.70	3.00	0.81	908	3.59	2.91	0.81	928	3.47	2.81	0.81	969
27	22	4.02	2.77	0.69	887	3.87	2.67	0.69	944	3.78	2.61	0.69	969	3.62	2.50	0.69	1010
27	24	4.22	2.41	0.57	928	4.06	2.32	0.57	979	3.97	2.26	0.57	1010	3.84	2.19	0.57	1061
27	26	4.35	1.96	0.45	979	4.22	1.90	0.45	1030	4.16	1.87	0.45	1061	4.03	1.81	0.45	1091
28	18	3.70	3.59	0.97	816	3.54	3.44	0.97	857	3.40	3.30	0.97	898	3.28	3.18	0.97	938
28	20	3.86	3.28	0.85	857	3.70	3.15	0.85	908	3.59	3.05	0.85	928	3.47	2.95	0.85	969
28	22	4.02	2.93	0.73	887	3.87	2.83	0.73	944	3.78	2.76	0.73	969	3.62	2.64	0.73	1010
28	24	4.22	2.57	0.61	928	4.06	2.48	0.61	979	3.97	2.42	0.61	1010	3.84	2.34	0.61	1061
28	26	4.35	2.13	0.49	979	4.22	2.07	0.49	1030	4.16	2.04	0.49	1061	4.03	1.98	0.49	1091
29	18	3.70	3.70	1.00	816	3.54	3.54	1.00	857	3.40	3.40	1.00	898	3.28	3.28	1.00	938
29	20	3.86	3.43	0.89	857	3.70	3.29	0.89	908	3.59	3.20	0.89	928	3.47	3.08	0.89	969
29	22	4.02	3.09	0.77	887	3.87	2.98	0.77	944	3.78	2.91	0.77	969	3.62	2.79	0.77	1010
29	24	4.22	2.74	0.65	928	4.06	2.64	0.65	979	3.97	2.58	0.65	1010	3.84	2.50	0.65	1061
29	26	4.35	2.30	0.53	979	4.22	2.24	0.53	1030	4.16	2.20	0.53	1061	4.03	2.14	0.53	1091
30	18	3.70	3.70	1.00	816	3.54	3.54	1.00	857	3.40	3.40	1.00	898	3.28	3.28	1.00	938
30	20	3.86	3.59	0.93	857	3.70	3.44	0.93	908	3.59	3.34	0.93	928	3.47	3.22	0.93	969
30	22	4.02	3.25	0.81	887	3.87	3.14	0.81	944	3.78	3.06	0.81	969	3.62	2.93	0.81	1010
30	24	4.22	2.91	0.69	928	4.06	2.80	0.69	979	3.97	2.74	0.69	1010	3.84	2.65	0.69	1061
30	26	4.35	2.48	0.57	979	4.22	2.41	0.57	1030	4.16	2.37	0.57	1061	4.03	2.30	0.57	1091
31	18	3.70	3.70	1.00	816	3.54	3.54	1.00	857	3.40	3.40	1.00	898	3.28	3.28	1.00	938
31	20	3.86	3.74	0.97	857	3.70	3.59	0.97	908	3.59	3.48	0.97	928	3.47	3.36	0.97	969
31	22	4.02	3.41	0.85	887	3.87	3.29	0.85	944	3.78	3.21	0.85	969	3.62	3.08	0.85	1010
31	24	4.22	3.08	0.73	928	4.06	2.97	0.73	979	3.97	2.90	0.73	1010	3.84	2.81	0.73	1061
31	26	4.35	2.65	0.61	979	4.22	2.57	0.61	1030	4.16	2.54	0.61	1061	4.03	2.46	0.61	1091
32	18	3.70	3.70	1.00	816	3.54	3.54	1.00	857	3.40	3.40	1.00	898	3.28	3.28	1.00	938
32	20	3.86	3.86	1.00	857	3.70	3.70	1.00	908	3.59	3.59	1.00	928	3.47	3.47	1.00	969
32	22	4.02	3.57	0.89	887	3.87	3.45	0.89	944	3.78	3.36	0.89	969	3.62	3.22	0.89	1010
32	24	4.22	3.25	0.77	928	4.06	3.13	0.77	979	3.97	3.06	0.77	1010	3.84	2.96	0.77	1061
32	26	4.35	2.83	0.65	979	4.22	2.74	0.65	1030	4.16	2.70	0.65	1061	4.03	2.62	0.65	1091

NOTE Q : Total capacity (kW) SHF : Sensible heat factor DB : Dry-bulb temperature  
SHC : Sensible heat capacity (kW) INPUT : Total power input (W) WB : Wet-bulb temperature

**PERFORMANCE DATA COOL operation at Rated frequency**

**MUZ-DM35VA**

CAPACITY: 3.15 kW

SHF: 0.87

INPUT: 1020 W

INDOOR DB (°C)	INDOOR WB (°C)	OUTDOOR DB (°C)											
		35				40				46			
		Q	SHC	SHF	INPUT	Q	SHC	SHF	INPUT	Q	SHC	SHF	INPUT
21	18	3.09	2.13	0.69	1000	2.84	1.96	0.69	1061	2.61	1.80	0.69	1102
21	20	3.24	1.85	0.57	1040	3.02	1.72	0.57	1091	2.80	1.60	0.57	1153
22	18	3.09	2.25	0.73	1000	2.84	2.07	0.73	1061	2.61	1.91	0.73	1102
22	20	3.24	1.98	0.61	1040	3.02	1.84	0.61	1091	2.80	1.71	0.61	1153
22	22	3.43	1.68	0.49	1081	3.21	1.57	0.49	1142	2.99	1.47	0.49	1183
23	18	3.09	2.38	0.77	1000	2.84	2.18	0.77	1061	2.61	2.01	0.77	1102
23	20	3.24	2.11	0.65	1040	3.02	1.97	0.65	1091	2.80	1.82	0.65	1153
23	22	3.43	1.82	0.53	1081	3.21	1.70	0.53	1142	2.99	1.59	0.53	1183
24	18	3.09	2.50	0.81	1000	2.84	2.30	0.81	1061	2.61	2.12	0.81	1102
24	20	3.24	2.24	0.69	1040	3.02	2.09	0.69	1091	2.80	1.93	0.69	1153
24	22	3.43	1.96	0.57	1081	3.21	1.83	0.57	1142	2.99	1.71	0.57	1183
24	24	3.62	1.63	0.45	1122	3.40	1.53	0.45	1173	3.21	1.45	0.45	1224
25	18	3.09	2.62	0.85	1000	2.84	2.41	0.85	1061	2.61	2.22	0.85	1102
25	20	3.24	2.37	0.73	1040	3.02	2.21	0.73	1091	2.80	2.05	0.73	1153
25	22	3.43	2.09	0.61	1081	3.21	1.96	0.61	1142	2.99	1.83	0.61	1183
25	24	3.62	1.78	0.49	1122	3.40	1.67	0.49	1173	3.21	1.57	0.49	1224
26	18	3.09	2.75	0.89	1000	2.84	2.52	0.89	1061	2.61	2.33	0.89	1102
26	20	3.24	2.50	0.77	1040	3.02	2.33	0.77	1091	2.80	2.16	0.77	1153
26	22	3.43	2.23	0.65	1081	3.21	2.09	0.65	1142	2.99	1.95	0.65	1183
26	24	3.62	1.92	0.53	1122	3.40	1.80	0.53	1173	3.21	1.70	0.53	1224
26	26	3.81	1.56	0.41	1163	3.59	1.47	0.41	1214	3.37	1.38	0.41	1265
27	18	3.09	2.87	0.93	1000	2.84	2.64	0.93	1061	2.61	2.43	0.93	1102
27	20	3.24	2.63	0.81	1040	3.02	2.45	0.81	1091	2.80	2.27	0.81	1153
27	22	3.43	2.37	0.69	1081	3.21	2.22	0.69	1142	2.99	2.06	0.69	1183
27	24	3.62	2.06	0.57	1122	3.40	1.94	0.57	1173	3.21	1.83	0.57	1224
27	26	3.81	1.72	0.45	1163	3.59	1.62	0.45	1214	3.37	1.52	0.45	1265
28	18	3.09	2.99	0.97	1000	2.84	2.75	0.97	1061	2.61	2.54	0.97	1102
28	20	3.24	2.76	0.85	1040	3.02	2.57	0.85	1091	2.80	2.38	0.85	1153
28	22	3.43	2.51	0.73	1081	3.21	2.35	0.73	1142	2.99	2.18	0.73	1183
28	24	3.62	2.21	0.61	1122	3.40	2.08	0.61	1173	3.21	1.96	0.61	1224
28	26	3.81	1.87	0.49	1163	3.59	1.76	0.49	1214	3.37	1.65	0.49	1265
29	18	3.09	3.09	1.00	1000	2.84	2.84	1.00	1061	2.61	2.61	1.00	1102
29	20	3.24	2.89	0.89	1040	3.02	2.69	0.89	1091	2.80	2.50	0.89	1153
29	22	3.43	2.64	0.77	1081	3.21	2.47	0.77	1142	2.99	2.30	0.77	1183
29	24	3.62	2.35	0.65	1122	3.40	2.21	0.65	1173	3.21	2.09	0.65	1224
29	26	3.81	2.02	0.53	1163	3.59	1.90	0.53	1214	3.37	1.79	0.53	1265
30	18	3.09	3.09	1.00	1000	2.84	2.84	1.00	1061	2.61	2.61	1.00	1102
30	20	3.24	3.02	0.93	1040	3.02	2.81	0.93	1091	2.80	2.61	0.93	1153
30	22	3.43	2.78	0.81	1081	3.21	2.60	0.81	1142	2.99	2.42	0.81	1183
30	24	3.62	2.50	0.69	1122	3.40	2.35	0.69	1173	3.21	2.22	0.69	1224
30	26	3.81	2.17	0.57	1163	3.59	2.05	0.57	1214	3.37	1.92	0.57	1265
31	18	3.09	3.09	1.00	1000	2.84	2.84	1.00	1061	2.61	2.61	1.00	1102
31	20	3.24	3.15	0.97	1040	3.02	2.93	0.97	1091	2.80	2.72	0.97	1153
31	22	3.43	2.92	0.85	1081	3.21	2.73	0.85	1142	2.99	2.54	0.85	1183
31	24	3.62	2.64	0.73	1122	3.40	2.48	0.73	1173	3.21	2.35	0.73	1224
31	26	3.81	2.33	0.61	1163	3.59	2.19	0.61	1214	3.37	2.06	0.61	1265
32	18	3.09	3.09	1.00	1000	2.84	2.84	1.00	1061	2.61	2.61	1.00	1102
32	20	3.24	3.24	1.00	1040	3.02	3.02	1.00	1091	2.80	2.80	1.00	1153
32	22	3.43	3.06	0.89	1081	3.21	2.86	0.89	1142	2.99	2.66	0.89	1183
32	24	3.62	2.79	0.77	1122	3.40	2.62	0.77	1173	3.21	2.47	0.77	1224
32	26	3.81	2.48	0.65	1163	3.59	2.33	0.65	1214	3.37	2.19	0.65	1265

**NOTE** Q : Total capacity (kW) SHF : Sensible heat factor DB : Dry-bulb temperature  
 SHC : Sensible heat capacity (kW) INPUT : Total power input (W) WB : Wet-bulb temperature

**PERFORMANCE DATA HEAT operation at Rated frequency**  
**MUZ-DM25VA**

CAPACITY: 3.15 kW      INPUT: 850 W

INDOOR DB (°C)	OUTDOOR WB (°C)													
	-10		-5		0		5		10		15		20	
	Q	INPUT	Q	INPUT	Q	INPUT	Q	INPUT	Q	INPUT	Q	INPUT	Q	INPUT
15	1.98	553	2.39	663	2.80	748	3.21	808	3.62	859	4.00	884	4.41	901
21	1.89	595	2.27	706	2.68	782	3.06	842	3.47	884	3.84	910	4.24	944
26	1.70	638	2.11	748	2.49	825	2.90	884	3.31	927	3.69	952	4.10	978

**MUZ-DM35VA**

CAPACITY: 3.6 kW      INPUT: 975 W

INDOOR DB (°C)	OUTDOOR WB (°C)													
	-10		-5		0		5		10		15		20	
	Q	INPUT	Q	INPUT	Q	INPUT	Q	INPUT	Q	INPUT	Q	INPUT	Q	INPUT
15	2.27	634	2.74	761	3.20	858	3.67	926	4.14	985	4.57	1014	5.04	1034
21	2.16	683	2.59	809	3.06	897	3.49	965	3.96	1014	4.39	1043	4.84	1082
26	1.94	731	2.41	858	2.84	946	3.31	1014	3.78	1063	4.21	1092	4.68	1121

**NOTE** Q: Total capacity (kW)    INPUT : Total power input (W)    DB: Dry-bulb temperature    WB: Wet-bulb temperature

**MUZ-DM25VA MUZ-DM35VA**

**9-1. OUTDOOR FAN MOTOR CONTROL**

The fan motor turns ON/OFF, interlocking with the compressor.

[ON] The fan motor turns ON 5 seconds before the compressor starts up.

[OFF] The fan motor turns OFF 15 seconds after the compressor has stopped running.

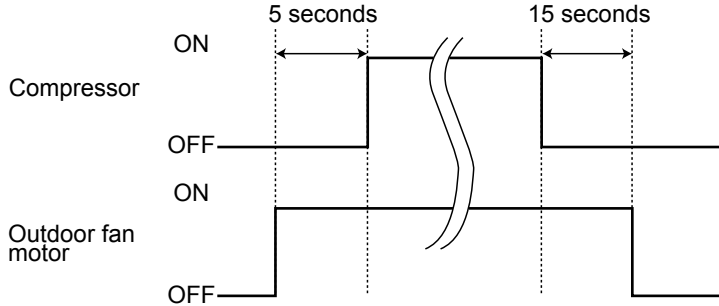

**9-2. R.V. COIL CONTROL**

**R.V. COIL CONTROL**

Heating ..... OFF

Cooling ..... ON

Dry ..... ON

**NOTE:** The 4-way valve reverses for 5 seconds right before start-up of the compressor.

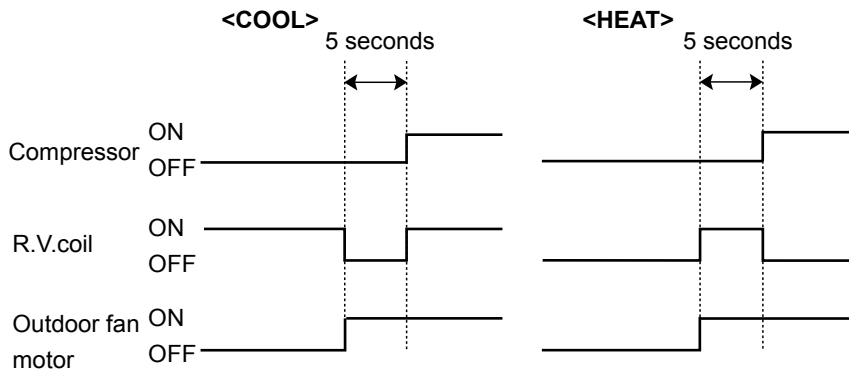

**9-3. RELATION BETWEEN MAIN SENSOR AND ACTUATOR**

Sensor	Purpose	Actuator				
		Compressor	LEV	Outdoor fan motor	R.V. coil	Indoor fan motor
Discharge temperature thermistor	Protection	○	○			
Indoor coil temperature thermistor	Cooling: Coil frost prevention	○				
	Heating: High pressure protection	○				
Defrost thermistor	Cooling: High pressure protection	○	○	○		
	Heating: Defrosting	○	○	○	○	○
Fin temperature thermistor	Protection	○		○		

**MUZ-DM25VA MUZ-DM35VA****10-1. CHANGE IN DEFROST SETTING**

<JS> When the JS wire of the inverter P.C. board is cut/ soldered, the defrost finish temperature is changed. (Refer to 11-6-1.)

Jumper wire		Defrost finish temperature (°C)
		MUZ-DM25/35VA
JS	Soldered (Initial setting)	8
	None (Cut)	11

**10-2. PRE-HEAT CONTROL SETTING****PRE-HEAT CONTROL**

When moisture gets into the refrigerant cycle, it may interfere the start-up of the compressor at low outside temperature. The pre-heat control prevents this interference. The pre-heat control turns ON when the discharge temperature thermostat is 20°C or below. When pre-heat control turns ON, compressor is energized. (About 50 W)

**Pre-heat control setting**

<JK>

ON: To activate the pre-heat control, cut the JK wire of the inverter P.C. board.

OFF: To deactivate the pre-heat control, solder the JK wire of the inverter P.C. board. (Refer to 11-6.1)

**NOTE:** When the inverter P.C. board is replaced, check the jumper wires, and cut/solder them if necessary.

**MUZ-DM25VA MUZ-DM35VA****11-1. CAUTIONS ON TROUBLESHOOTING****1. Before troubleshooting, check the following:**

- 1) Check the power supply voltage.
- 2) Check the indoor/outdoor connecting wire for miswiring.

**2. Take care of the following during servicing**

- 1) Before servicing the air conditioner, be sure to turn OFF the main unit first with the remote controller, and then after confirming the horizontal vane is closed, turn OFF the breaker and/or disconnect the power plug.
- 2) Be sure to turn OFF the power supply before removing the front panel, the cabinet, the top panel, and the electronic control P.C. board.
- 3) When removing the electrical parts, be careful to the residual voltage of smoothing capacitor.
- 4) When removing the electronic control P.C. board, hold the edge of the board with care NOT to apply stress on the components.
- 5) When connecting or disconnecting the connectors, hold the connector housing. DO NOT pull the lead wires.

&lt;Incorrect&gt;

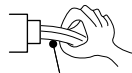
**Lead wiring**

&lt;Correct&gt;

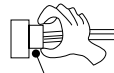
**Connector housing****3. Troubleshooting procedure**

- 1) Check if the OPERATION INDICATOR lamp on the indoor unit is flashing on and off to indicate an abnormality. To make sure, check how many times the OPERATION INDICATOR lamp is flashing on and off before starting service work.
- 2) Before servicing, check that the connector and terminal are connected properly.
- 3) When the electronic control P.C. board seems to be defective, check the copper foil pattern for disconnection and the components for bursting and discoloration.
- 4) Refer to 11-2 and 11-3.

## 11-2. FAILURE MODE RECALL FUNCTION

Outline of the function

This air conditioner can memorize the abnormal condition which has occurred once.

Even though LED indication listed on the troubleshooting check table (11-3.) disappears, the memorized failure details can be recalled.

This mode is very useful when the unit needs to be repaired for the abnormality which does not recur.

### 1. Flow chart of failure mode recall function for the indoor/outdoor unit

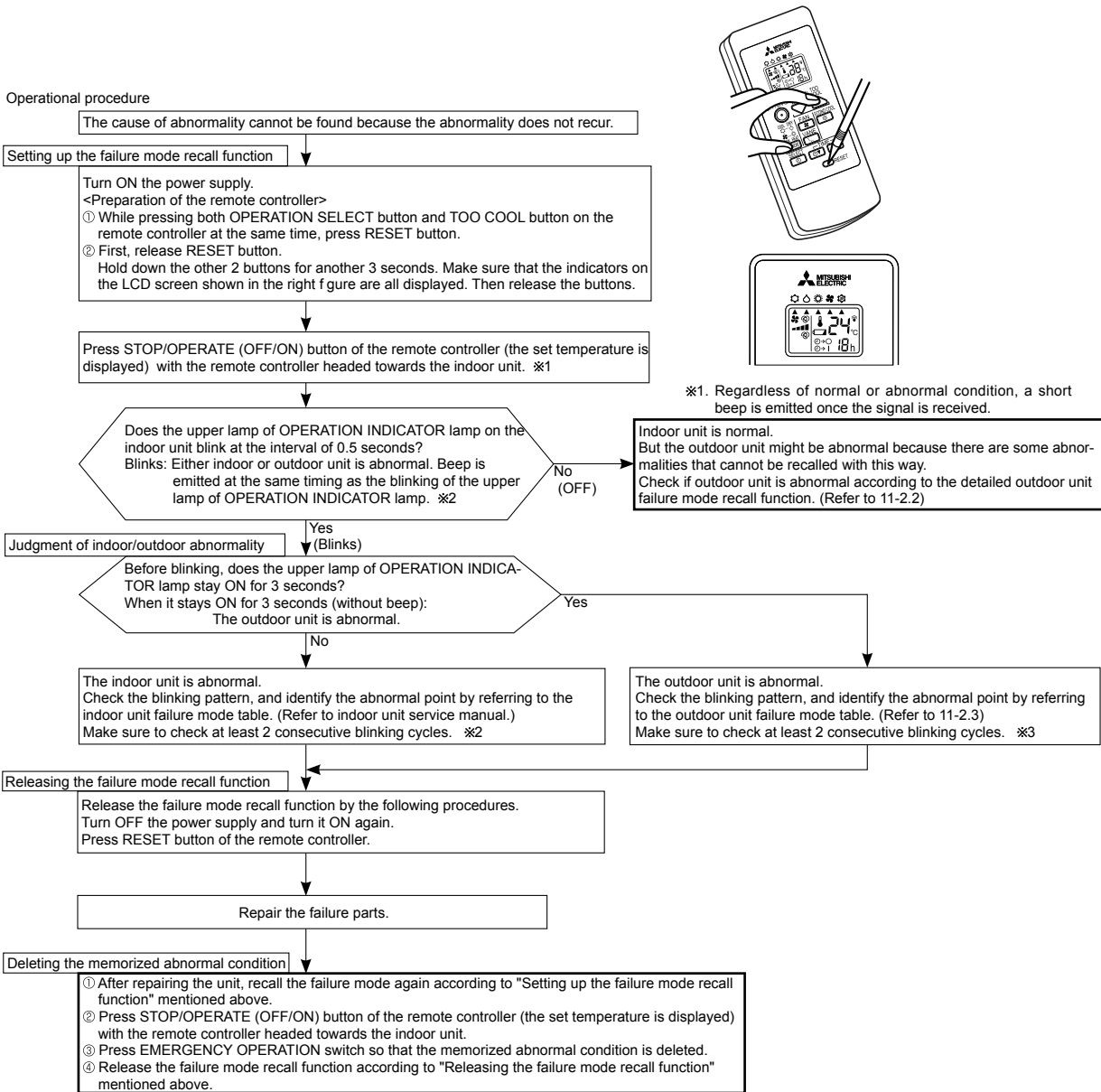

**NOTE:** 1. Make sure to release the failure mode recall function after it is set up, otherwise the unit cannot operate properly.  
 2. If the abnormal condition is not deleted from the memory, the last abnormal condition is kept memorized.

\*2. Blinking pattern when the indoor unit is abnormal:

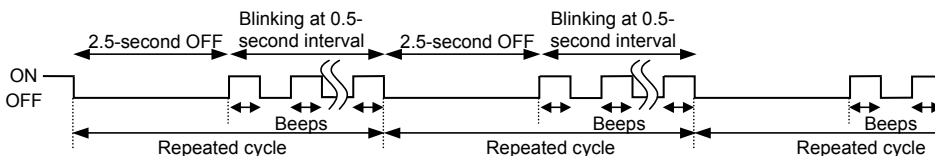

\*3. Blinking pattern when the outdoor unit is abnormal:

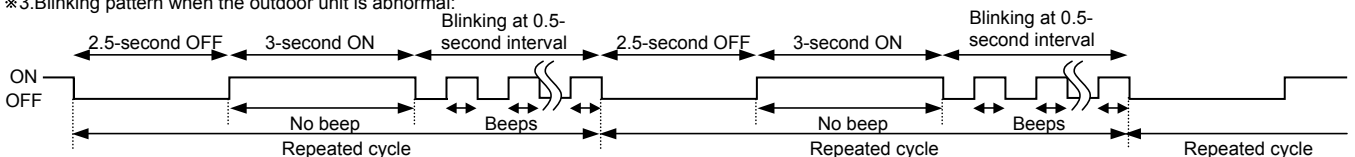

## 2. Flow chart of the detailed outdoor unit failure mode recall function

### Operational procedure

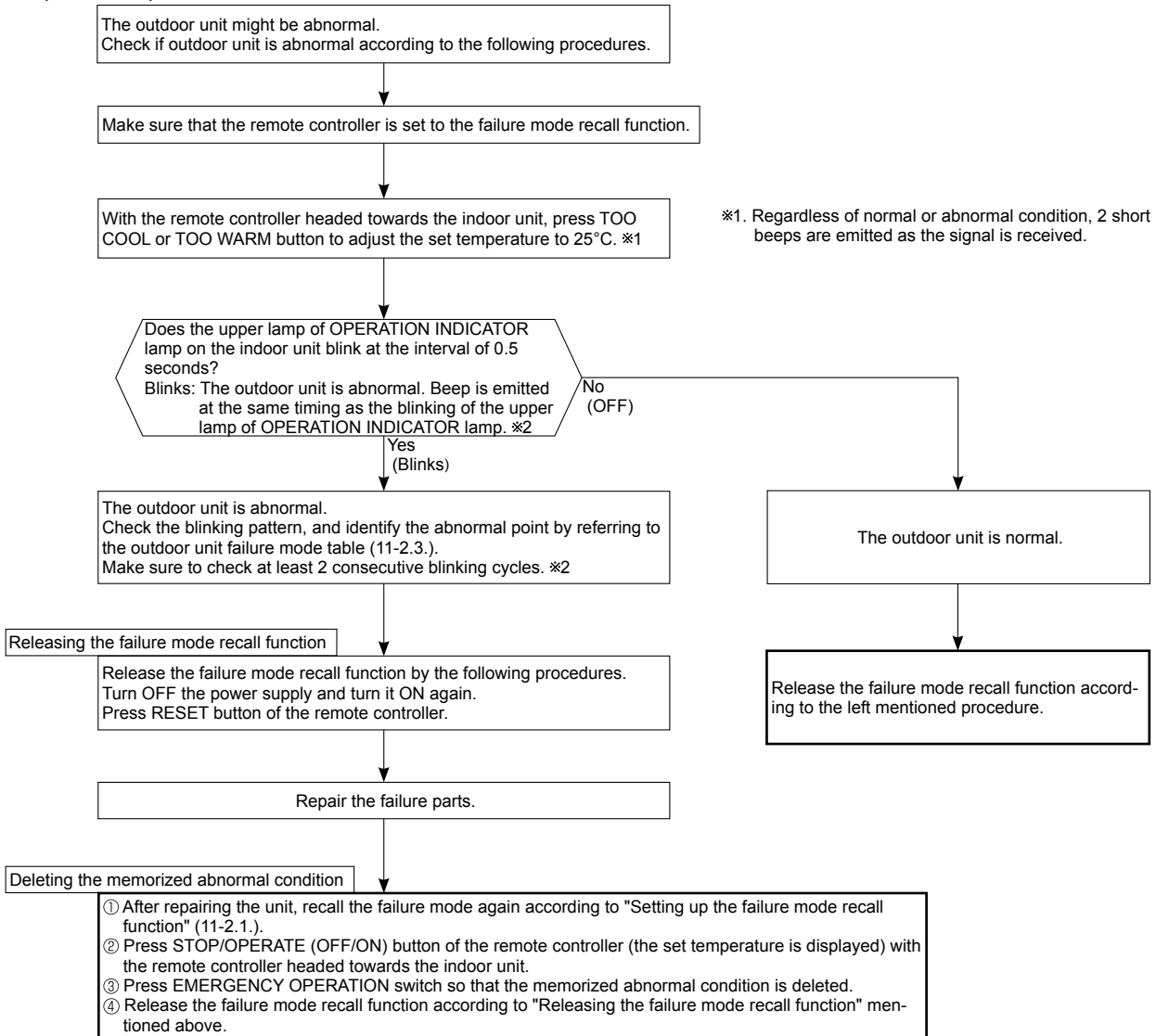

**NOTE:** 1. Make sure to release the failure mode recall function after it is set up, otherwise the unit cannot operate properly.  
2. If the abnormal condition is not deleted from the memory, the last abnormal condition is kept memorized.

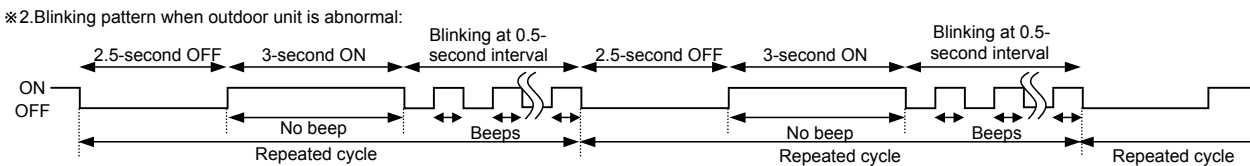



### 3. Outdoor unit failure mode table

The upper lamp of OPERATION INDICATOR lamp (Indoor unit)	Abnormal point (Failure mode/protection)	LED indication (Outdoor P.C. board)	Condition	Remedy	Indoor/outdoor unit failure mode recall function	Outdoor unit failure mode recall function
OFF	None (Normal)	—	—	—	—	—
1-time f ash 2.5 seconds OFF	Indoor/outdoor communication, receiving error	—	Any signals from the inverter P.C. board cannot be received normally for 3 minutes.	•Refer to 11-5. ㉑ How to check miswiring and serial signal error.	○	○
	Indoor/outdoor communication, receiving error	—	Although the inverter P.C. board sends signal "0", signal "1" has been received 30 consecutive times.	•Refer to 11-5. ㉑ How to check miswiring and serial signal error.		
2-time f ash 2.5 seconds OFF	Outdoor power system	—	Overcurrent protection cut-out operates 3 consecutive times within 1 minute after the compressor gets started.	•Reconnect connectors. •Refer to 11-5. ㉒ How to check inverter/compressor". •Check stop valve.	○	○
3-time f ash 2.5 seconds OFF	Discharge temperature thermistor	1-time f ash every 2.5 seconds	Thermistor shorts or opens during compressor running.	•Refer to 11-5. ㉓ "Check of outdoor thermistors". Defective outdoor thermistors can be identified by checking the blinking pattern of LED.	○	○
	Defrost thermistor	3-time f ash 2.5 seconds OFF				
	Fin temperature thermistor					
	P.C. board temperature thermistor					
4-time f ash 2.5 seconds OFF	Overcurrent	11-time f ash 2.5 seconds OFF	Large current flows into power module.	•Reconnect compressor connector. •Refer to 11-5. ㉔ How to check inverter/compressor". •Check stop valve.	—	○
	Compressor synchronous abnormality (Compressor start-up failure protection)	12-time f ash 2.5 seconds OFF	Waveform of compressor current is distorted.	•Reconnect compressor connector. •Refer to 11-5. ㉔ How to check inverter/compressor".	—	○
5-time f ash 2.5 seconds OFF	Discharge temperature	—	Temperature of discharge temperature thermistor exceeds 116°C, compressor stops. Compressor can restart if discharge temperature thermistor reads 100°C or less 3 minutes later.	•Check refrigerant circuit and refrigerant amount. •Refer to 11-5. ㉕ Check of LEV".	—	○
6-time f ash 2.5 seconds OFF	High pressure	—	Temperature of indoor coil thermistor exceeds 70°C in HEAT mode. Temperature of defrost thermistor exceeds 70°C in COOL mode.	•Check refrigerant circuit and refrigerant amount. •Check stop valve.	—	○
7-time f ash 2.5 seconds OFF	Fin temperature/ P.C. board temperature	7-time f ash 2.5 seconds OFF	Temperature of fin temperature thermistor on the inverter P.C. board exceeds 80°C or temperature of P.C. board temperature thermistor on the inverter P.C. board exceeds 78°C.	•Check around outdoor unit. •Check outdoor unit air passage. •Refer to 11-5. ㉖ Check of outdoor fan motor".	—	○
9-time f ash 2.5 seconds OFF	Nonvolatile memory data	5-time f ash 2.5 seconds OFF	Nonvolatile memory data cannot be read properly.	•Replace the inverter P.C. board.	○	○
	Power module	6-time f ash 2.5 seconds OFF	The interface short circuit occurs in the output of the power module (IC700). The compressor winding shorts circuit.	•Refer to 11-5. ㉗ How to check inverter/compressor".		
10-time f ash 2.5 seconds OFF	Discharge temperature	—	Temperature of discharge temperature thermistor has been 50°C or less for 20 minutes.	•Refer to 11-5. ㉘ Check of LEV". •Check refrigerant circuit and refrigerant amount.	—	○

**NOTE:** Blinking patterns of this mode differ from the ones of TROUBLESHOOTING CHECK TABLE (11-3.).



The upper lamp of OPERATION INDICATOR lamp (Indoor unit)	Abnormal point (Failure mode/protection)	LED indication (Outdoor P.C. board)	Condition	Remedy	Indoor/outdoor unit failure mode recall function	Outdoor unit failure mode recall function
11-time f ash 2.5 seconds OFF	DC voltage	8-time f ash 2.5 seconds OFF	DC voltage of inverter cannot be detected normally.	•Refer to 11-5.④"How to check inverter/compressor".	—	○
	Each phase current of compressor	9-time f ash 2.5 seconds OFF	Each phase current of compressor cannot be detected normally.			
14-time f ash or more 2.5 seconds OFF	Stop valve (Closed valve)	14-time f ash 2.5 seconds OFF	Closed valve is detected by compressor current.	•Check stop valve.	○	○
	4-way valve/ Pipe temperature	16-time f ash 2.5 seconds OFF	The 4-way valve does not work properly. The indoor coil thermistor detects an abnormal temperature.	•Check 4-way valve. •Replace inverter P.C. board.		
	Outdoor refrigerant system abnormality	17-time f ash 2.5 seconds OFF	A closed valve and air trapped in the refrigerant circuit are detected based on the temperature sensed by the indoor and outdoor thermistors and the current of the compressor.	•Check for a gas leak in a connecting piping etc. •Check the stop valve. •Refer to 11-5. ④ "Check of outdoor refrigerant circuit".		

**NOTE:** Blinking patterns of this mode differ from the ones of TROUBLESHOOTING CHECK TABLE (11-3.).

### 11-3. TROUBLESHOOTING CHECK TABLE

No.	Symptom	LED indication	Abnormal point/Condition	Condition	Remedy
1	Outdoor unit does not operate.	1-time flash every 2.5 seconds	Outdoor power system	Overcurrent protection cut-out operates 3 consecutive times within 1 minute after the compressor gets started, or failure of restart of compressor has repeated 24 times.	•Reconnect connector of compressor. •Refer to 11-5.Ⓐ "How to check inverter/compressor". •Check stop valve.
2			Outdoor thermistors	Discharge temperature thermistor, fin temperature thermistor, defrost thermistor, P.C. board temperature thermistor or outdoor heat exchanger temperature thermistor shorts or opens during compressor running.	•Refer to 11-5.Ⓒ "Check of outdoor thermistors".
3			Outdoor control system	Nonvolatile memory data cannot be read properly. (The upper lamp of OPERATION INDICATOR lamp of the indoor unit lights up or flashes 7-time.)	•Replace inverter P.C. board.
4			Serial signal	The communication fails between the indoor and outdoor unit for 3 minutes.	•Refer to 11-5.Ⓓ "How to check miswiring and serial signal error."
5	'Outdoor unit stops and restarts 3 minutes later' is repeated.	6-time flash 2.5 seconds OFF	Stop valve/ Closed valve	Closed valve is detected by compressor current.	•Check stop valve.
6		11-time flash 2.5 seconds OFF	4-way valve/ Pipe temperature	The 4-way valve does not work properly. The indoor coil thermistor detects an abnormal temperature.	•Refer to 11-5.Ⓔ "Check of R.V. coil". •Replace inverter P.C. board.
7		16-time flash 2.5 seconds OFF	Outdoor refrigerant system abnormality	A closed valve and air trapped in the refrigerant circuit are detected based on the temperature sensed by the indoor and outdoor thermistors and the current of the compressor.	•Check for a gas leak in a connecting piping etc. •Check the stop valve. •Refer to 11-5.Ⓜ "Check of outdoor refrigerant circuit".
8		17-time flash 2.5 seconds OFF	Overcurrent protection	Large current flows into power module. ※When overcurrent protection occurs within 10 seconds after compressor starts, compressor restarts after 15 seconds.	•Reconnect connector of compressor. •Refer to 11-5.Ⓐ "How to check inverter/compressor". •Check stop valve.
9		3-time flash 2.5 seconds OFF	Discharge temperature overheat protection	Temperature of discharge temperature thermistor exceeds 116°C, compressor stops. Compressor can restart if discharge temperature thermistor reads 100°C or less 3 minutes later.	•Check refrigerant circuit and refrigerant amount. •Refer to 11-5.Ⓢ "Check of LEV".
10		4-time flash 2.5 seconds OFF	Fin temperature /P.C. board temperature thermistor overheat protection	Temperature of fin temperature thermistor on the heat sink exceeds 80°C or temperature of P.C. board temperature thermistor on the inverter P.C. board exceeds 78°C.	•Check around outdoor unit. •Check outdoor unit air passage. •Refer to 11-5.Ⓙ "Check of outdoor fan motor".
11		5-time flash 2.5 seconds OFF	High pressure protection	Indoor coil thermistor exceeds 70°C in HEAT mode. Defrost thermistor exceeds 70°C in COOL mode.	•Check refrigerant circuit and refrigerant amount. •Check stop valve.
12	8-time flash 2.5 seconds OFF	Compressor synchronous abnormality	The waveform of compressor current is distorted.	•Reconnect connector of compressor. •Refer to 11-5.Ⓐ "How to check inverter/compressor".	
13	12-time flash 2.5 seconds OFF	Each phase current of compressor	Each phase current of compressor cannot be detected normally.	•Refer to 11-5.Ⓐ "How to check inverter/compressor".	
14	13-time flash 2.5 seconds OFF	DC voltage	DC voltage of inverter cannot be detected normally.	•Refer to 11-5.Ⓐ "How to check inverter/compressor".	
15	Outdoor unit operates.	1-time flash 2.5 seconds OFF	Frequency drop by current protection	When the input current exceeds 5.4 A (DM25)/6.1 A (DM35), compressor frequency lowers.	The unit is normal, but check the following. •Check if indoor filters are clogged. •Check if refrigerant is short. •Check if indoor/outdoor unit air circulation is short cycled.
16		3-time flash 2.5 seconds OFF	Frequency drop by high pressure protection	Temperature of indoor coil thermistor exceeds 55°C in HEAT mode, compressor frequency lowers.	
16		3-time flash 2.5 seconds OFF	Frequency drop by defrosting in COOL mode	Indoor coil thermistor reads 8°C or less in COOL mode, compressor frequency lowers.	
17		4-time flash 2.5 seconds OFF	Frequency drop by discharge temperature protection	Temperature of discharge temperature thermistor exceeds 111°C, compressor frequency lowers.	
18	5-time flash 2.5 seconds OFF	Outside temperature thermistor protection	When the outside temperature thermistor shorts or opens, protective operation without that thermistor is performed.	•Refer to 11-5.Ⓢ Check of outdoor thermistors.	

NOTE: 1. The location of LED is illustrated at the right figure. Refer to 11-6.1.  
2. LED is lighted during normal operation.

The flashing frequency shows the number of times the LED blinks after every 2.5-second OFF.  
(Example) When the flashing frequency is "2".

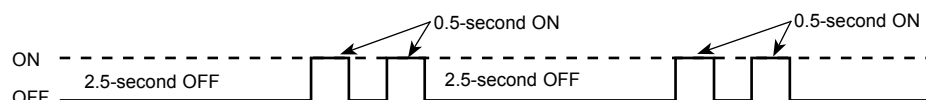

Inverter P.C. board

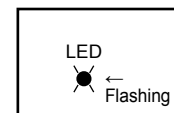



No.	Symptom	LED indication	Abnormal point/Condition	Condition	Remedy
20	Outdoor unit operates.	7-time flash 2.5 seconds OFF	Low discharge temperature protection	Temperature of discharge temperature thermistor has been 50°C or less for 20 minutes.	<ul style="list-style-type: none"> <li>Refer to 11-5.Ⓢ "Check of LEV".</li> <li>Check refrigerant circuit and refrigerant amount.</li> </ul>
21		8-time flash 2.5 seconds OFF	PAM protection PAM: Pulse Amplitude Modulation	The overcurrent flows into IC821 (Switching power transistor) or the bus-bar voltage reaches 320 V or more, PAM stops and restarts.	This is not malfunction. PAM protection will be activated in the following cases: 1 Instantaneous power voltage drop. (Short time power failure) 2 When the power supply voltage is high.
22		9-time flash 2.5 seconds OFF	Inverter check mode	The connector of compressor is disconnected, inverter check mode starts.	<ul style="list-style-type: none"> <li>Check if the connector of the compressor is correctly connected.</li> <li>Refer to 11-5.Ⓐ "How to check inverter/compressor".</li> </ul>

**NOTE:** 1. The location of LED is illustrated at the right figure. Refer to 11-6.1.  
 2. LED is lighted during normal operation.

The flashing frequency shows the number of times the LED blinks after every 2.5-second OFF.  
 (Example) When the flashing frequency is "2".

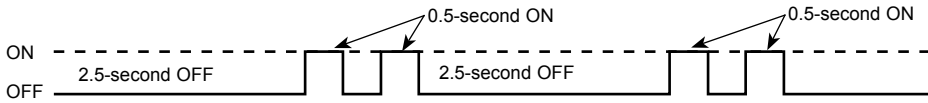

Inverter P.C. board

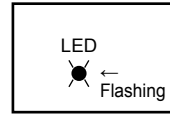



**11-4. TROUBLE CRITERION OF MAIN PARTS**  
**MUZ-DM25VA MUZ-DM35VA**

Part name	Check method and criterion	Figure										
Defrost thermistor (RT61)	<p>Measure the resistance with a tester.</p> <p>Refer to 11-6. "Test point diagram and voltage", 1. "Inverter P.C. board", for the chart of thermistor.</p>	/										
Discharge temperature thermistor (RT62) Fin temperature thermistor (RT64)	<p>Measure the resistance with a tester.</p> <p>Before measurement, hold the thermistor with your hands to warm it up.</p> <p>Refer to 11-6. "Test point diagram and voltage", 1. "Inverter P.C. board", for the chart of thermistor.</p>											
Compressor (MC)	<p>Measure the resistance between the terminals with a tester.            (Part temperature -10 - 40°C)</p> <table border="1" style="margin-left: auto; margin-right: auto;"> <thead> <tr> <th colspan="2">Normal</th> </tr> </thead> <tbody> <tr> <td>U-V</td> <td><b>MUZ-DM25VA</b></td> </tr> <tr> <td>U-W</td> <td><b>MUZ-DM35VA</b></td> </tr> <tr> <td>V-W</td> <td>2.01 - 2.86 Ω</td> </tr> <tr> <td></td> <td>1.20 - 1.72 Ω</td> </tr> </tbody> </table>	Normal		U-V	<b>MUZ-DM25VA</b>	U-W	<b>MUZ-DM35VA</b>	V-W	2.01 - 2.86 Ω		1.20 - 1.72 Ω	
Normal												
U-V	<b>MUZ-DM25VA</b>											
U-W	<b>MUZ-DM35VA</b>											
V-W	2.01 - 2.86 Ω											
	1.20 - 1.72 Ω											
Outdoor fan motor (MF)	<p>Measure the resistance between lead wires with a tester.            (Part temperature -10 - 40°C)</p> <table border="1" style="margin-left: auto; margin-right: auto;"> <thead> <tr> <th>Color of lead wire</th> <th>Normal</th> </tr> </thead> <tbody> <tr> <td>RED - BLK</td> <td rowspan="3" style="text-align: center;">85 - 90 Ω</td> </tr> <tr> <td>BLK - WHT</td> </tr> <tr> <td>WHT - RED</td> </tr> </tbody> </table>	Color of lead wire	Normal	RED - BLK	85 - 90 Ω	BLK - WHT	WHT - RED					
Color of lead wire	Normal											
RED - BLK	85 - 90 Ω											
BLK - WHT												
WHT - RED												
R.V. coil (21S4)	<p>Measure the resistance between the terminals with a tester.            (Part temperature -10°C - 40°C)</p> <table border="1" style="margin-left: auto; margin-right: auto;"> <thead> <tr> <th>Normal</th> </tr> </thead> <tbody> <tr> <td>1.19 - 1.78 kΩ</td> </tr> </tbody> </table>	Normal	1.19 - 1.78 kΩ	/								
Normal												
1.19 - 1.78 kΩ												
Expansion valve coil (LEV)	<p>Measure the resistance using a tester.            (Part temperature: -10 - 40°C)</p> <table border="1" style="margin-left: auto; margin-right: auto;"> <thead> <tr> <th>Color of lead wire</th> <th>Normal</th> </tr> </thead> <tbody> <tr> <td>WHT - BRN</td> <td rowspan="4" style="text-align: center;">37 - 54 Ω</td> </tr> <tr> <td>BRN - ORN</td> </tr> <tr> <td>YLW - RED</td> </tr> <tr> <td>RED - BLU</td> </tr> </tbody> </table>	Color of lead wire	Normal	WHT - BRN	37 - 54 Ω	BRN - ORN	YLW - RED	RED - BLU				
Color of lead wire	Normal											
WHT - BRN	37 - 54 Ω											
BRN - ORN												
YLW - RED												
RED - BLU												



## 11-5. TROUBLESHOOTING FLOW

### A How to check inverter/compressor

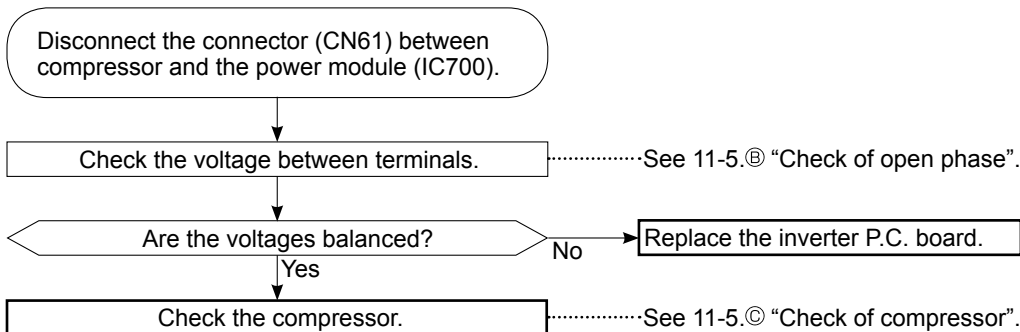

### B Check of open phase

- With the connector between the compressor and the power module disconnected, activate the inverter and check if the inverter is normal by measuring the **balance of voltage** between the terminals.

Output voltage is 50 - 130 V. (The voltage may differ according to the tester.)

<< Operation method >>

Start cooling or heating operation by pressing EMERGENCY OPERATION switch on the indoor unit. (TEST RUN OPERATION : Refer to 8-3.)

<< Measurement point >>

At 3 points

BLK (U)-WHT (V)

BLK (U)-RED (W)

WHT(V)-RED (W)

※ Measure AC voltage between the lead wires at 3 points.

- NOTE :**
1. Output voltage varies according to power supply voltage.
  2. Measure the voltage by analog type tester.
  3. During this check, LED of the inverter P.C. board flashes 9 times. (Refer to 11-6.1.)

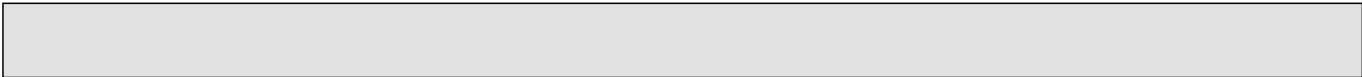

### C Check of compressor

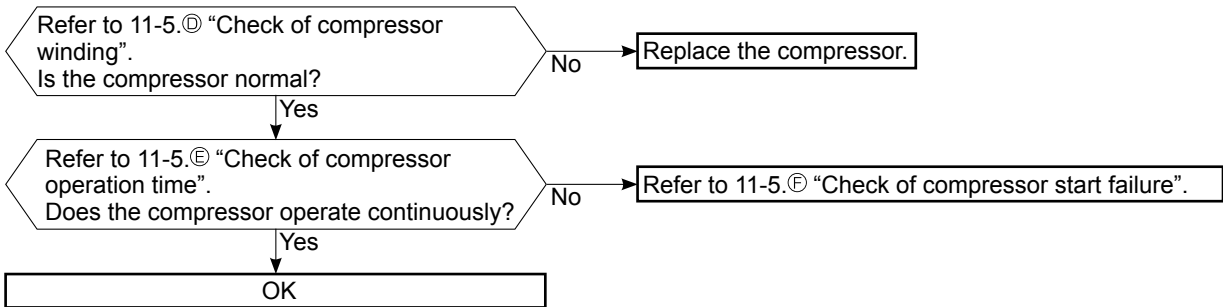

### D Check of compressor winding

- Disconnect the connector (CN61) between the compressor and power module, and measure the resistance between the compressor terminals.
- <<Measurement point>>  
 At 3 points  
 BLK-WHT  
 BLK-RED      \* Measure the resistance between the lead wires at 3 points.  
 WHT-RED
- <<Judgement>>  
 Refer to 11-4.  
 0 [Ω] .....Abnormal [short]  
 Infinite [Ω] .....Abnormal [open]
- NOTE** : Be sure to zero the ohmmeter before measurement.

### E Check of compressor operation time

- Connect the compressor and activate the inverter. Then measure the time until the inverter stops due to overcurrent.
- <<Operation method>>  
 Start heating or cooling operation by pressing EMERGENCY OPERATION switch on the indoor unit. (TEST RUN OPERATION: Refer to 8-3.)
- <<Measurement>>  
 Measure the time from the start of compressor to the stop of compressor due to overcurrent.

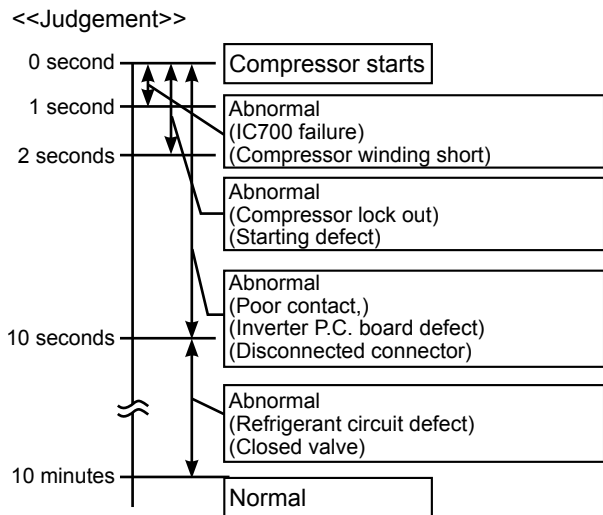

## F Check of compressor start failure

Make sure that ①~④ is normal.

•Electrical circuit check

- ①. Contact of the compressor connector (Including CN61)
- ②. Output voltage of inverter P.C. board and balance of them (See 11-5.㉔)
- ③. Direct current voltage between DB61(+) and (-) on the inverter P.C. board
- ④. Voltage between outdoor terminal block S1-S2

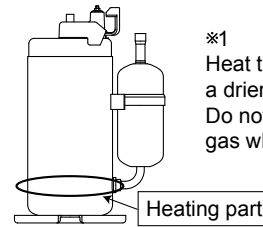
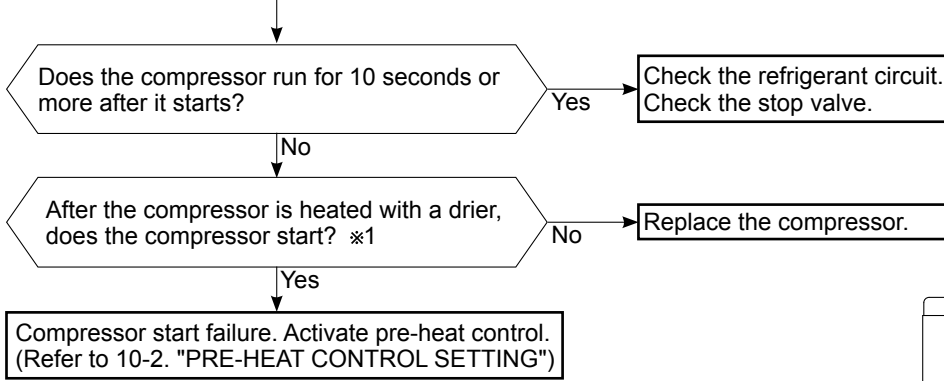

※1 Heat the compressor with a drier for about 20 minutes. Do not recover refrigerant gas while heating.

## G Check of outdoor thermistors

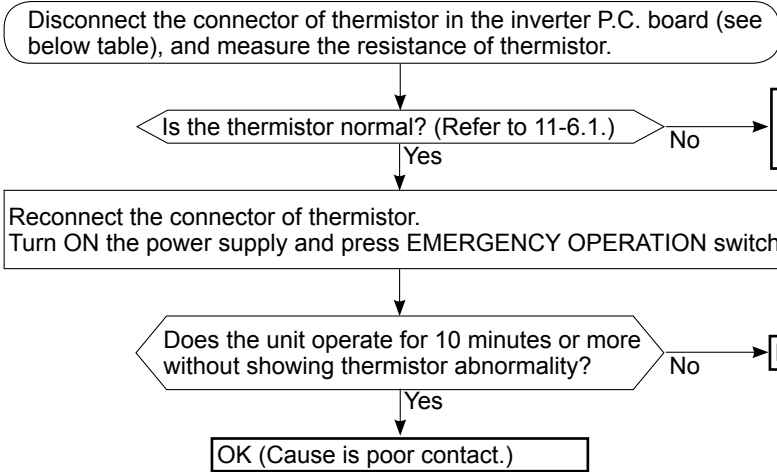

Thermistor	Symbol	Connector, Pin No.	Board
Defrost	RT61	Between CN641 pin 1 and pin 2	Inverter P.C. board
Discharge temperature	RT62	Between CN641 pin 3 and pin 4	
Fin temperature	RT64	Between CN642 pin 1 and pin 2	
Ambient temperature thermistor	RT65	Between CN643 pin 1 and pin 2	
Outdoor heat exchanger temperature	RT68	Between CN644 pin 1 and pin 3	





**H Check of R.V. coil**

- ※ First of all, measure the resistance of R.V. coil to check if the coil is defective. Refer to 11-4.
- ※ In case CN721 is not connected or R.V. coil is open, voltage is generated between the terminal pins of the connector although any signal is not being transmitted to R.V. coil.  
Check if CN721 is connected.

**Unit operates COOL mode even if it is set to HEAT mode.**

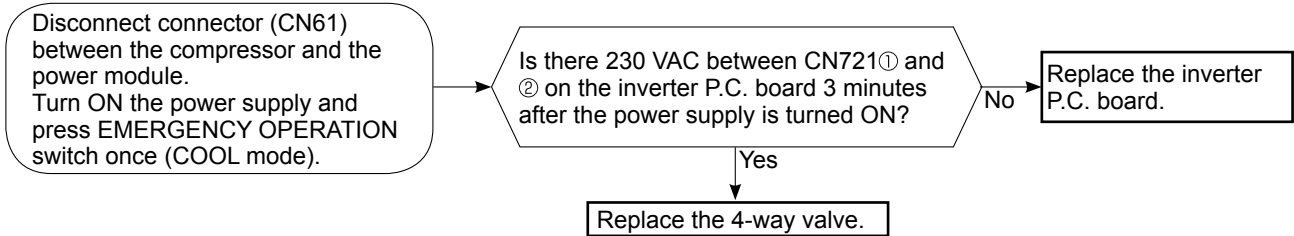

**Unit operates HEAT mode even if it is set to COOL mode.**

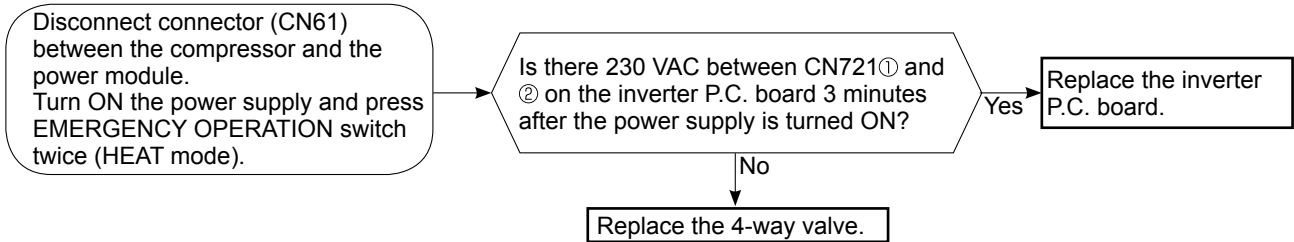



**① Check of outdoor fan motor**

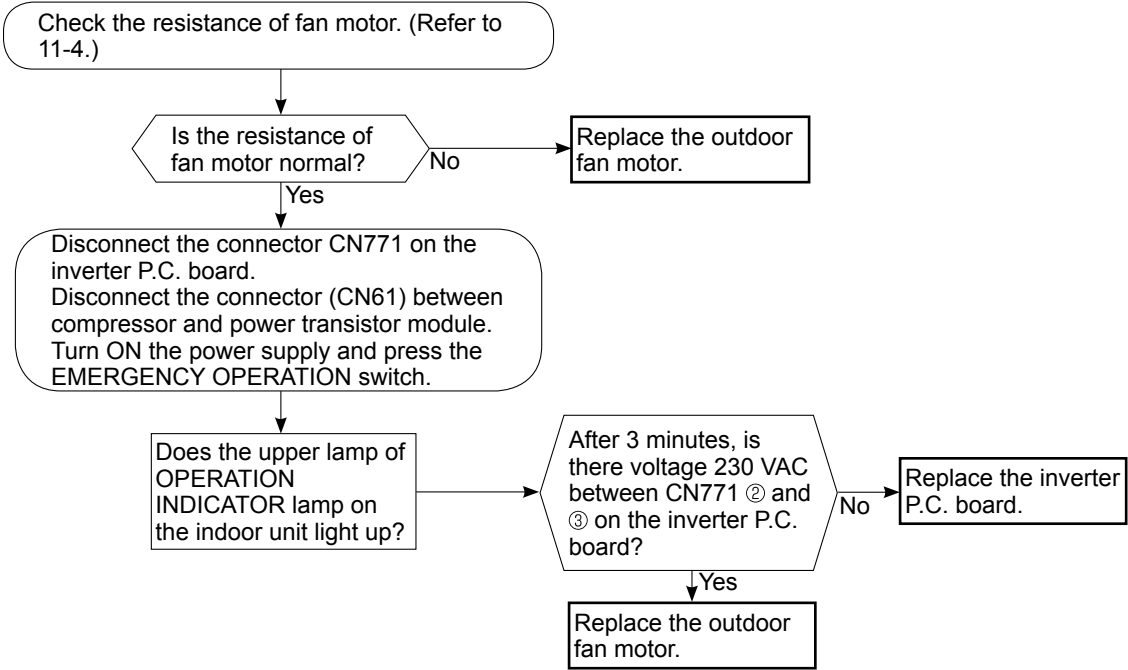

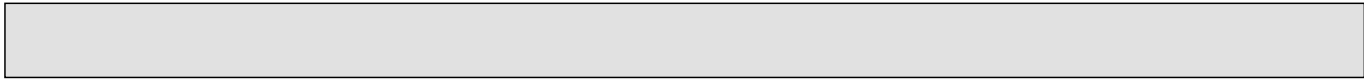

### J Check of power supply

Disconnect the connector (CN61) between compressor and power module.  
Turn ON power supply and press EMERGENCY OPERATION switch.

Does the upper lamp of OPERATION INDICATOR lamp on the indoor unit light up?

No

Rectify indoor/outdoor connecting wire.

Yes

Is there voltage 230 VAC between the indoor terminal block S1 and S2?

No

Replace the indoor electronic control P.C. board.

Yes

Is there voltage 250 - 370 VDC between DB61 (+) and DB61 (-) on the inverter P.C. board? (Refer to 11-6.1.)

Yes

Does LED on the inverter P.C. board light up or flash? (Refer to 11-6.1.)

No

Replace the inverter P.C. board.

No

Check the electric parts in main circuit.

If lights up, OK.  
If flashes, refer to 11-3.

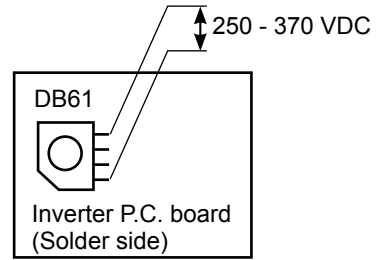

### K Check of LEV (Expansion valve)

Turn ON the power supply.  
<Preparation of the remote controller>  
① While pressing both OPERATION SELECT button and TOO COOL button on the remote controller at the same time, press RESET button.  
② First, release RESET button.  
Hold down the other 2 buttons for another 3 seconds. Make sure that the indicators on the LCD screen shown in the right figure are all displayed. Then release the buttons.

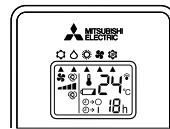
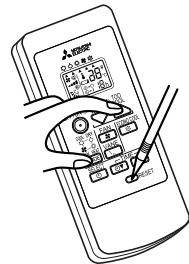

Press STOP/OPERATE (OFF/ON) button of the remote controller (the set temperature is displayed) with the remote controller headed towards the indoor unit. \*1

Expansion valve operates in full-opening direction.

Do you hear the expansion valve "click, click....."?  
Do you feel the expansion valve vibrate when touching it?

Yes

OK

No

Is LEV coil properly fixed to the expansion valve?

No

Properly fix the LEV coil to the expansion valve.

Yes

Does the resistance of LEV coil have the characteristics? (Refer to 11-4.)

Yes

Measure each voltage between connector pins of CN724 on the inverter P.C. board.  
1. Pin③(-) — Pin①(+)  
2. Pin④(-) — Pin①(+)  
3. Pin⑤(-) — Pin①(+)  
4. Pin⑥(-) — Pin①(+)  
Is there about 3 ~ 5 VAC between each?  
**NOTE:** Measure the voltage by an analog tester.

No

Replace the inverter P.C. board.

No

Replace the LEV coil.

Yes

Replace the expansion valve.

\*1. Regardless of normal or abnormal condition, a short beep is emitted once the signal is received.

**NOTE :** After check of LEV, do the undermentioned operations.  
1. Turn OFF the power supply and turn ON it again.  
2. Press RESET button on the remote controller.

## Ⓛ How to check miswiring and serial signal error

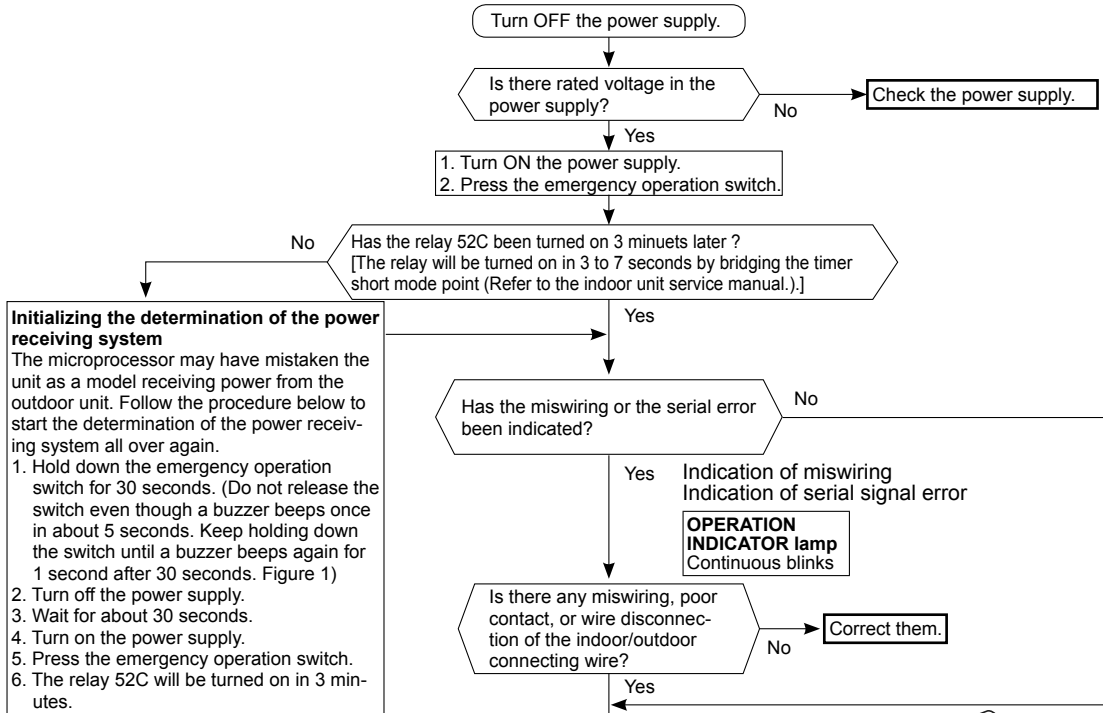
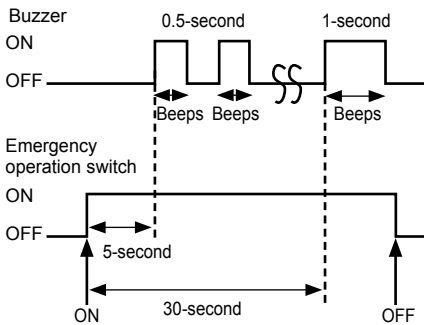

Figure 1



Turn OFF the power supply. Make sure again that the indoor/outdoor connecting wire is correctly connected. With the indoor/outdoor connecting wire connected, bridge between S2 and S3 on the outdoor terminal block. \*1

<Preparation of the remote controller>

① While pressing both OPERATION SELECT button and TOO COOL button on the remote controller at the same time, press RESET button.

② First, release RESET button. Hold down the other 2 buttons for another 3 seconds. Make sure that the indicators on the LCD screen shown in the right figure are all displayed. Then release the buttons. (Setting up the failure mode recall function)

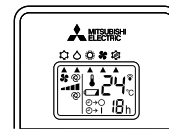
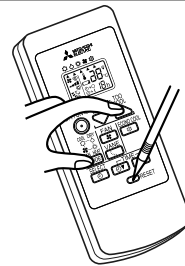

Aim the remote controller at the indoor unit, and press STOP/OPERATE (OFF/ON) button. The relay 52C will be turned on, and the outdoor unit will be energized.

\*1 Make sure that the wiring is correct. If the procedure is performed without correcting miswiring, it may lead to damage to the P.C. board.

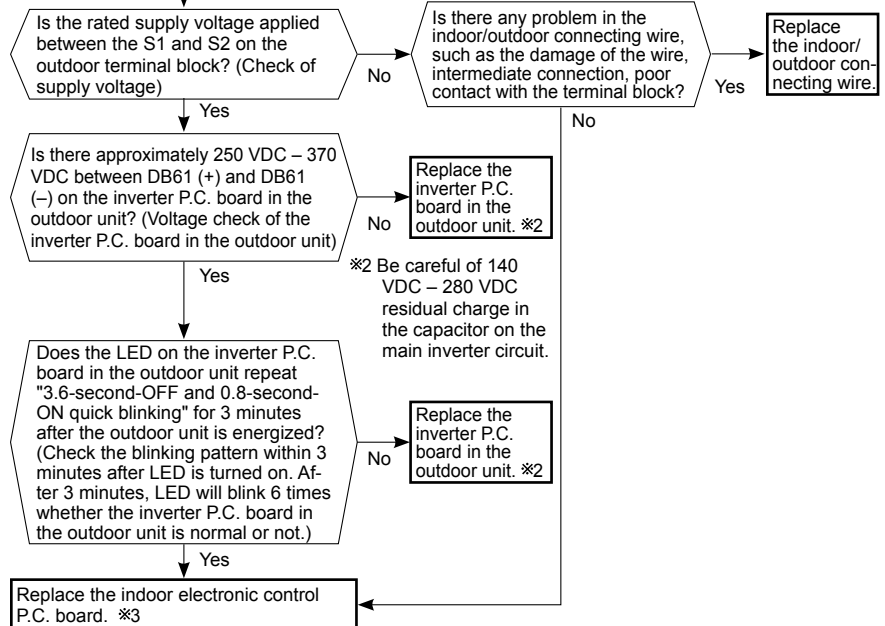
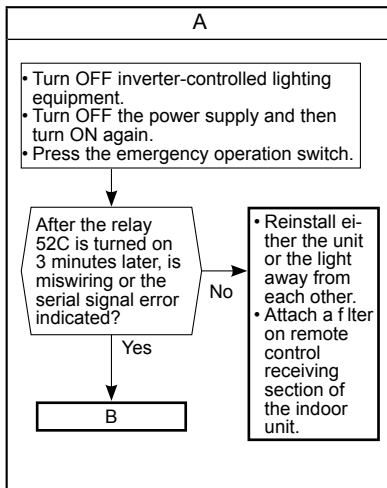

\*2 Be careful of 140 VDC – 280 VDC residual charge in the capacitor on the main inverter circuit.

\*3 Be sure to release the failure-mode recall function after checking.



**M Check of outdoor refrigerant circuit**

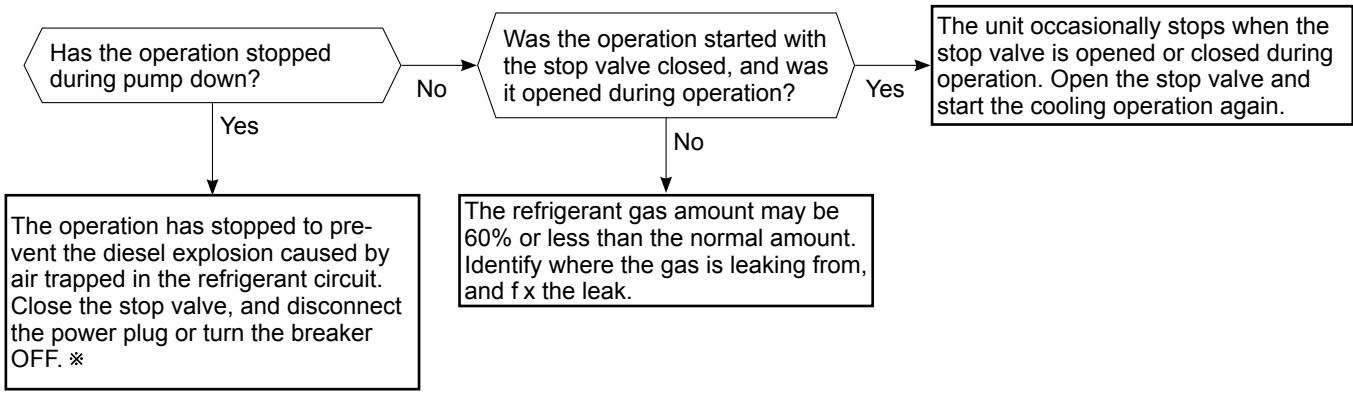

**\* CAUTION : Do not start the operation again to prevent hazards.**

## Ⓝ Electromagnetic noise enters into TV sets or radios

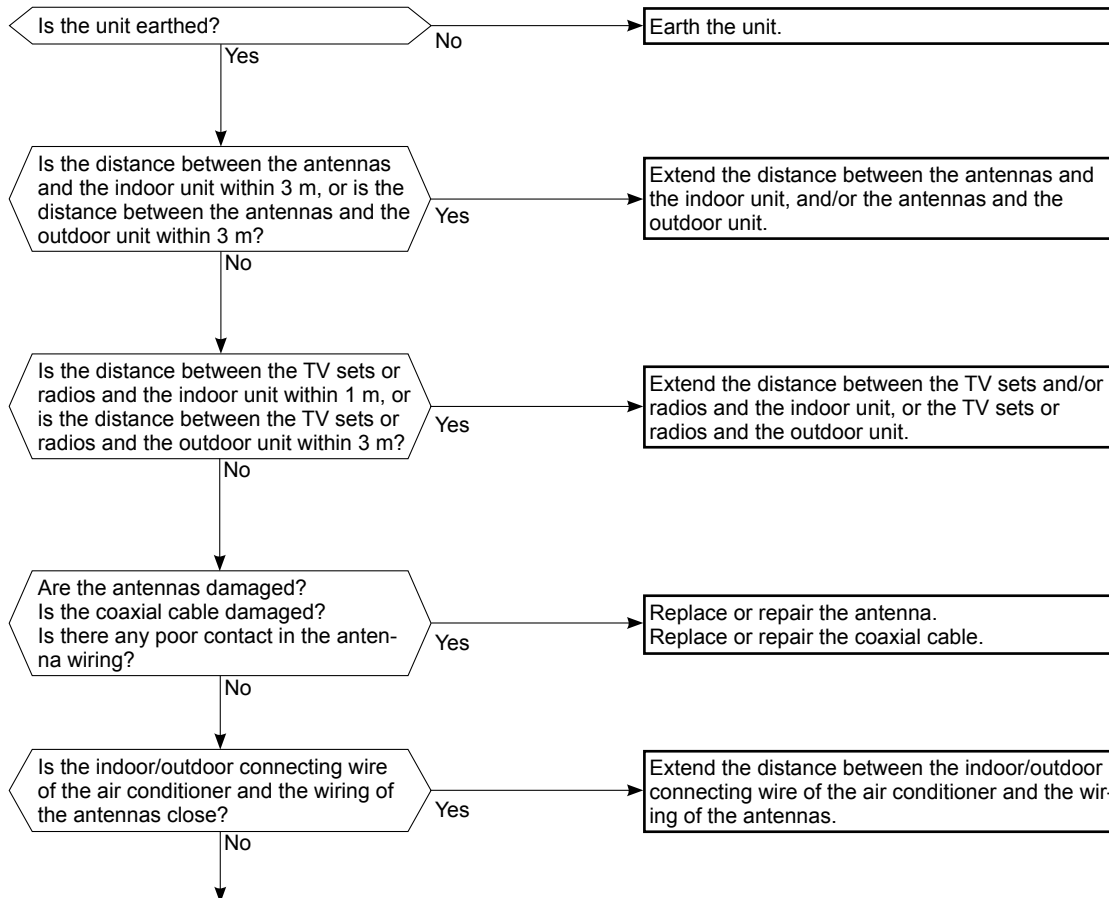

Even if all of the above conditions are fulfilled, the electromagnetic noise may enter, depending on the electric field strength or the installation condition (combination of specific conditions such as antennas or wiring). Check the following before asking for service.

1. Devices affected by the electromagnetic noise  
TV sets, radios (FM/AM broadcast, shortwave)
2. Channel, frequency, broadcast station affected by the electromagnetic noise
3. Channel, frequency, broadcast station unaffected by the electromagnetic noise
4. Layout of ;  
indoor/outdoor unit of the air conditioner, indoor/outdoor wiring, earth wire, antennas, wiring from antennas, receiver
5. Electric field intensity of the broadcast station affected by the electromagnetic noise
6. Presence or absence of amplifier such as booster
7. Operation condition of air conditioner when the electromagnetic noise enters in
  - 1) Turn OFF the power supply once, and then turn ON the power supply. In this situation, check for the electromagnetic noise.
  - 2) Within 3 minutes after turning ON the power supply, press STOP/OPERATE (OFF/ON) button on the remote controller for power ON, and check for the electromagnetic noise.
  - 3) After a short time (3 minutes later after turning ON), the outdoor unit starts running. During operation, check for the electromagnetic noise.
  - 4) Press STOP/OPERATE (OFF/ON) button on the remote controller for power OFF, when the outdoor unit stops but the indoor/outdoor communication still runs on. In this situation, check for the electromagnetic noise.

# 11-6. TEST POINT DIAGRAM AND VOLTAGE

## 1. Inverter P.C. board

### MUZ-DM25VA MUZ-DM35VA

Back side of unit

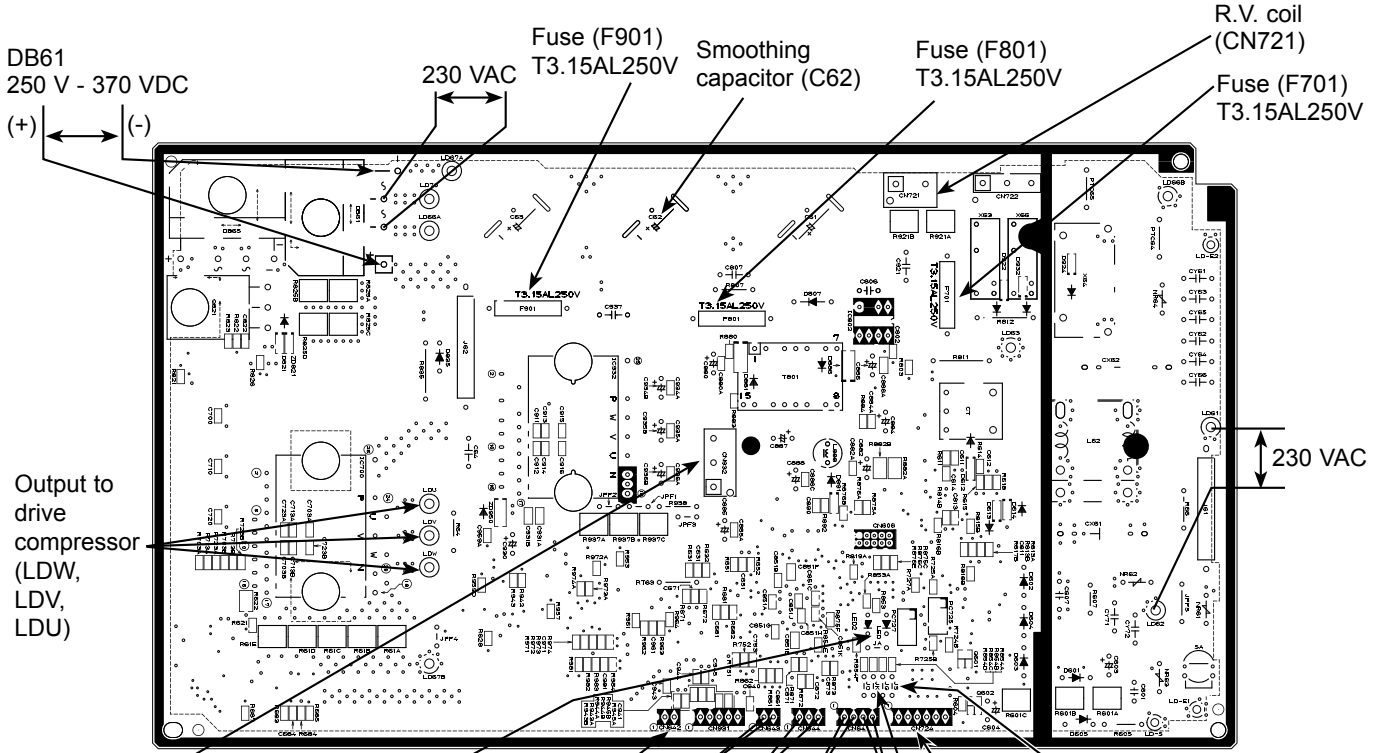

Output to drive outdoor fan motor (CN932)

LED

Front side of unit

Fin temperature thermistor/RT64 (CN642)

Defrost thermistor/RT65 (CN643)

Defrost thermistor/RT68 (CN644)

Defrost thermistor/RT61 (CN641)

Discharge temperature thermistor/RT62 (CN641)

LEV connector (CN724)

Jumper wire for changing defrost setting (JS)

Jumper wire for pre-heat control setting (JK)

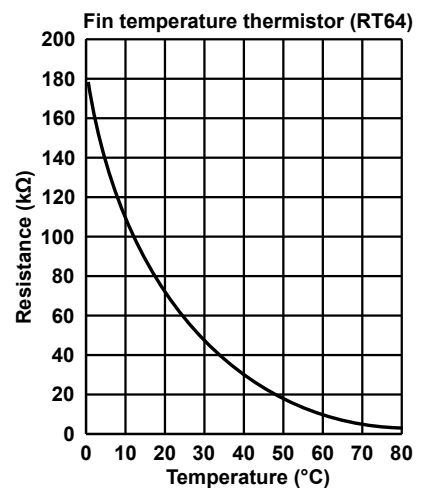
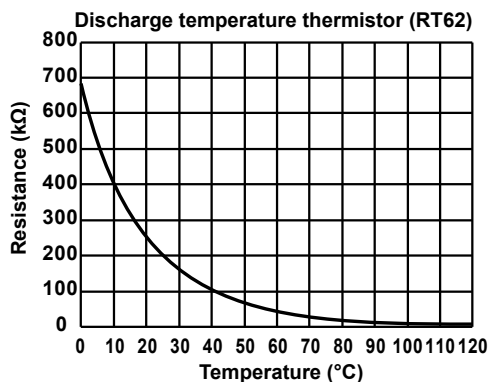
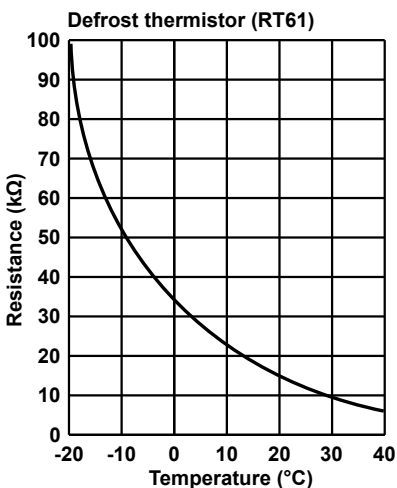

<"Terminal with locking mechanism" Detaching points>

The terminal which has the locking mechanism can be detached as shown below.

There are 2 types (refer to (1) and (2)) of the terminal with locking mechanism.

The terminal without locking mechanism can be detached by pulling it out.

Check the shape of the terminal before detaching.

(1) Slide the sleeve and check if there is a locking lever or not.

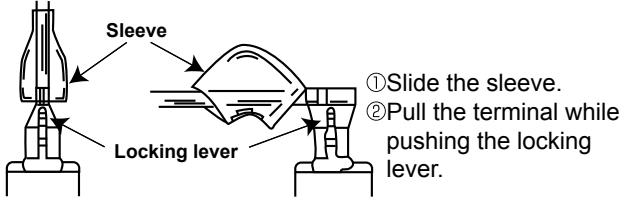

(2) The terminal with this connector has the locking mechanism.

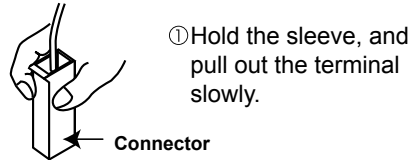

**12-1. MUZ-DM25VA MUZ-DM35VA**

**NOTE:** Turn OFF the power supply before disassembly.

OPERATING PROCEDURE	PHOTOS
<p><b>1. Removing the cabinet and the panels</b></p> <ol style="list-style-type: none"> <li>(1) Remove the screws fixing the service panel.</li> <li>(2) Pull down the service panel and remove it.</li> <li>(3) Disconnect the power supply and indoor/outdoor connecting wire.</li> <li>(4) Remove the screws fixing the top panel.</li> <li>(5) Remove the top panel.</li> <li>(6) Remove the screws fixing the cabinet and the motor support.</li> <li>(7) Remove the cabinet.</li> <li>(8) Remove the fixing screws of the terminal block support and the back panel. (Photo 4)</li> <li>(9) Remove the screws fixing the back panel.</li> <li>(10) Remove the back panel.</li> </ol> <p><b>Photo 2</b></p> <p>Screws of the top panel</p> <p>Direction to remove</p> <p>Screws of the service panel</p> <p>Hooks</p> <p>Screw of the cabinet</p>	<p><b>Photo 1</b></p> <p>Screws of the top panel</p> <p>Screws of the motor support</p> <p>Screws of the cabinet</p> <p><b>Photo 3</b></p> <p>Screws of the back panel</p>



## OPERATING PROCEDURE

### 2. Removing the inverter assembly, inverter P.C. board

- (1) Remove the cabinet and the panels. (Refer to 1.)
- (2) Disconnect the lead wire to the reactor and the following connectors:  
<Inverter P.C. board>  
CN721 (R.V. coil)  
CN931, CN932 (Fan motor)  
CN641 (Defrost thermistor and discharge temperature thermistor)  
CN643 (Ambient temperature thermistor)  
CN644 (Outdoor heat exchanger temperature thermistor)  
CN724 (LEV)
- (3) Remove the compressor connector (CN61).
- (4) Remove the screw fixing the heat sink support and the separator.
- (5) Remove the inverter assembly.
- (6) Remove the screws of the earth wire and the terminal block support.
- (7) Remove the screw of the terminal block and remove the terminal block.
- (8) Remove the heat sink support from the P.C. board support.
- (9) Unhook the catch of the inverter P.C. board and remove the inverter P.C. board from the P.C. board support.

### 3. Removing the R.V. coil

- (1) Remove the cabinet and the panels. (Refer to 1.)
- (2) Disconnect the following connectors:  
<Inverter P.C. board>  
CN721 (R.V. coil)
- (3) Remove the R.V. coil.

## PHOTOS

Photo 4

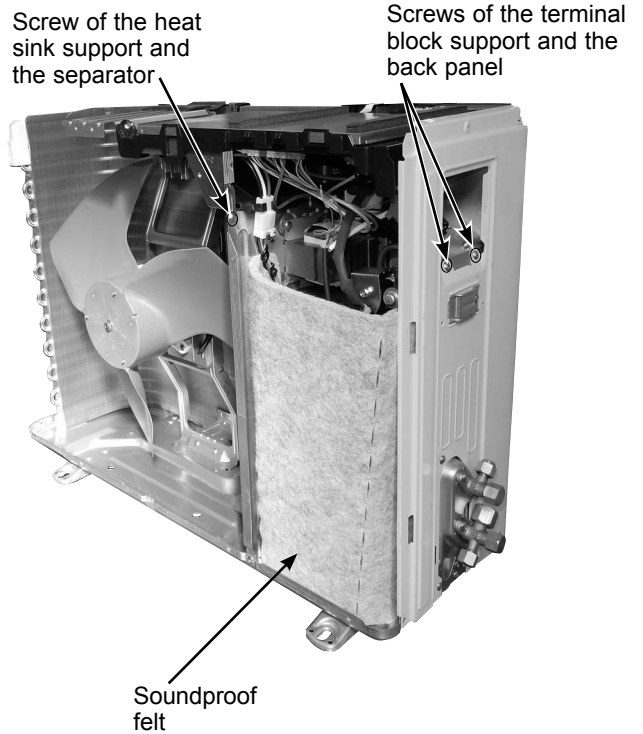
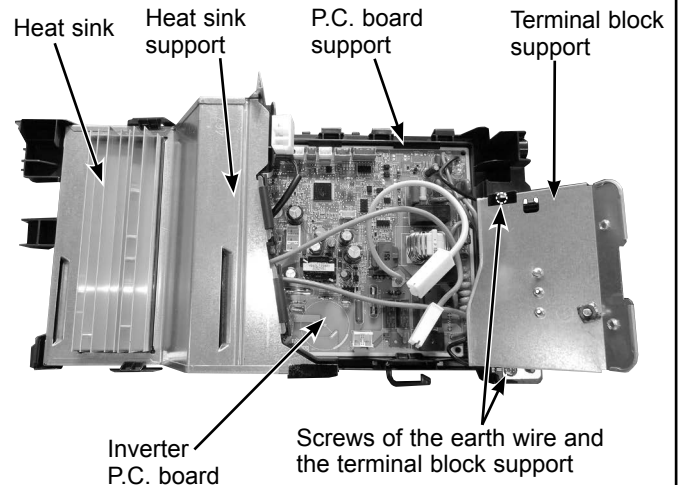

Photo 5 (Inverter assembly)



## OPERATING PROCEDURE

### 4. Removing the discharge temperature thermistor, the defrost thermistor, the ambient temperature thermistor and the outdoor heat exchanger temperature thermistor

- (1) Remove the cabinet and the panels. (Refer to 1.)
- (2) Disconnect the lead wire to the reactor and the following connectors:  
<Inverter P.C. board>  
CN641 (Defrost thermistor and discharge temperature thermistor)  
CN643 (Ambient temperature thermistor)  
CN644 (Outdoor heat exchanger temperature thermistor)
- (3) Pull out the discharge temperature thermistor from its holder.
- (4) Pull out the defrost thermistor from its holder. (Photo 9)
- (5) Pull out the outdoor heat exchanger temperature thermistor from its holder.
- (6) Pull out the ambient temperature thermistor from its holder.

### 5. Removing the outdoor fan motor

- (1) Remove the cabinet and the panels. (Refer to 1.)
- (2) Disconnect the following connectors:  
<Inverter P.C. board>  
CN931, CN932 (Fan motor)
- (3) Remove the fan motor lead wire from where it is fastened on the separator.
- (4) Remove the propeller fan nut.
- (5) Remove the propeller fan.
- (6) Remove the screws fixing the fan motor.
- (7) Remove the fan motor.

## PHOTOS

Photo 6

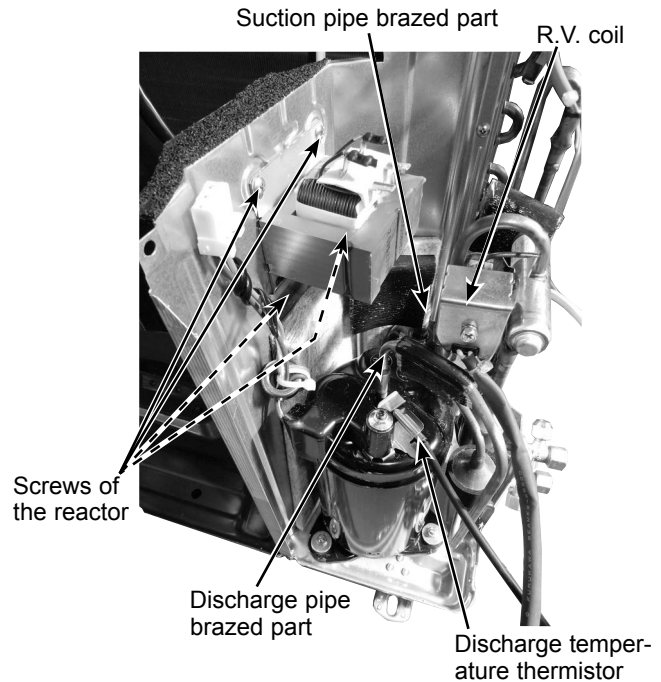

Photo 7

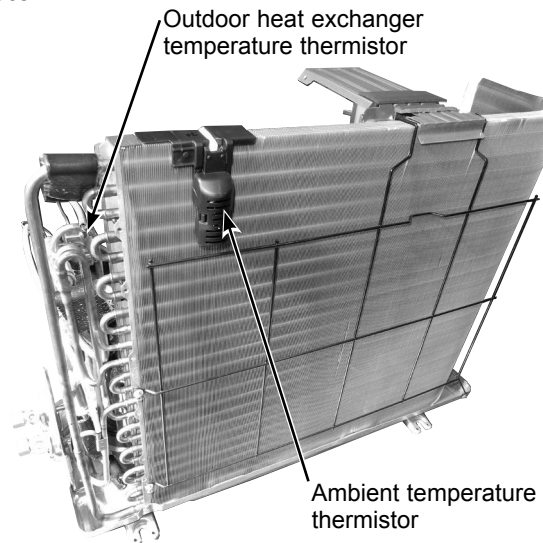
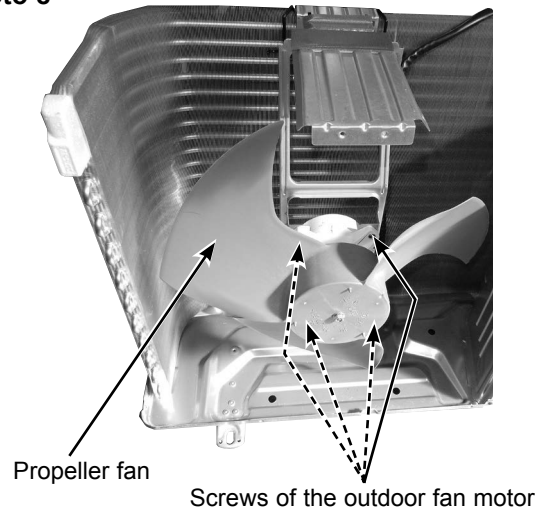
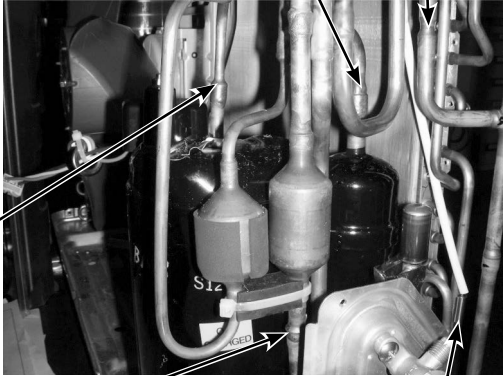

Photo 8





OPERATING PROCEDURE	PHOTOS
<p><b>6. Removing the compressor and the 4-way valve</b></p> <ul style="list-style-type: none"><li>(1) Remove the cabinet and the panels. (Refer to 1.)</li><li>(2) Remove the inverter assembly. (Refer to 2.)</li><li>(3) Remove the screws of the reactor and remove the reactor.</li><li>(4) Remove the screws of the separator and remove the separator.</li><li>(5) Remove the soundproof felt.</li><li>(6) Remove the terminal cover and the compressor lead wire.</li><li>(7) Recover gas from the refrigerant circuit. <b>NOTE:</b> Recover gas from the pipes until the pressure gauge shows 0 kg/cm<sup>2</sup> (0 MPa).</li><li>(8) Detach the brazed part of the suction and the discharge pipe connected with the compressor.</li><li>(9) Detach the brazed part of pipes connected with the 4-way valve.</li><li>(10) Remove the nuts of compressor legs.</li><li>(11) Remove the compressor.</li></ul>	<p><b>Photo 9</b></p>  <p>Suction pipe brazed part      4-way valve brazed part</p> <p>Discharge pipe brazed part</p> <p>4-way valve brazed part      Defrost thermistor</p>

# **MITSUBISHI ELECTRIC CORPORATION**

HEAD OFFICE: TOKYO BLDG., 2-7-3, MARUNOUCHI, CHIYODA-KU, TOKYO 100-8310, JAPAN

© Copyright 2015 MITSUBISHI ELECTRIC CORPORATION  
Distributed in Dec. 2015. No. OBH751  
Made in Japan

New publication, effective Dec. 2015  
Specifications are subject to change without notice.