

SPLIT-TYPE AIR CONDITIONERS

Revision F:
• Some descriptions have been modified.

OBB600 REVISED EDITION-E is void.

INDOOR UNIT PARTS CATALOG

No. OBB600
REVISED EDITION-F

Models

MSZ-SF25VE - E1, E2, EN1, EN2, ER2

MSZ-SF35VE - E1, E2, EN1, EN2, ER2

MSZ-SF42VE - E1, E2, EN1, EN2, ER2

MSZ-SF50VE - E1, E2, EN1, EN2, ER2

MSZ-SF25VE2 - E1, EN1, ER1

MSZ-SF35VE2 - E1, EN1, ER1

MSZ-SF42VE2 - E1, EN1, ER1

MSZ-SF50VE2 - E1, EN1, ER1

MSZ-SF25VE3 - E1, EN1, ER1

MSZ-SF35VE3 - E1, EN1, ER1

MSZ-SF42VE3 - E1, EN1, ER1

MSZ-SF50VE3 - E1, EN1, ER1

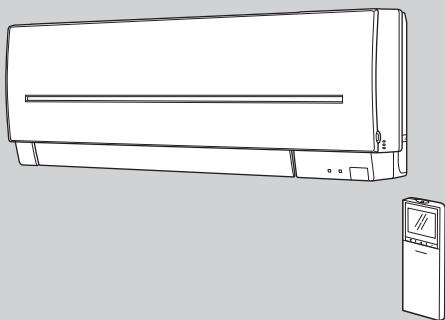

CONTENTS

1. SERVICE PARTS LIST	2
2. OPTIONAL PARTS	22

SERVICE MANUAL (OBH600)

Revision A:

• Part number of "INDOOR COIL THERMISTOR" has been changed.

Revision B:

• MSZ-SF25/35/42/50VE- **E2** and MSZ-SF25/35/42/50VE- **EN2** have been added.

Revision C:

• MSZ-SF25/35/42/50VE- **ER2** have been added.

Revision D:

• MSZ-SF25/35/42/50VE2- **E1**, **EN1**, **ER1** have been added.

Revision E:

• MSZ-SF25/35/42/50VE3- **E1**, **EN1**, **ER1** have been added.

Revision F:

• Some descriptions have been modified.

1 SERVICE PARTS LIST

MSZ-SF25VE- **E1**, **E2**, **EN1**, **EN2**

MSZ-SF35VE- **E1**, **E2**, **EN1**, **EN2**

MSZ-SF42VE- **E1**, **E2**, **EN1**, **EN2**

MSZ-SF50VE- **E1**, **E2**, **EN1**, **EN2**

1-1. INDOOR UNIT STRUCTURAL PARTS

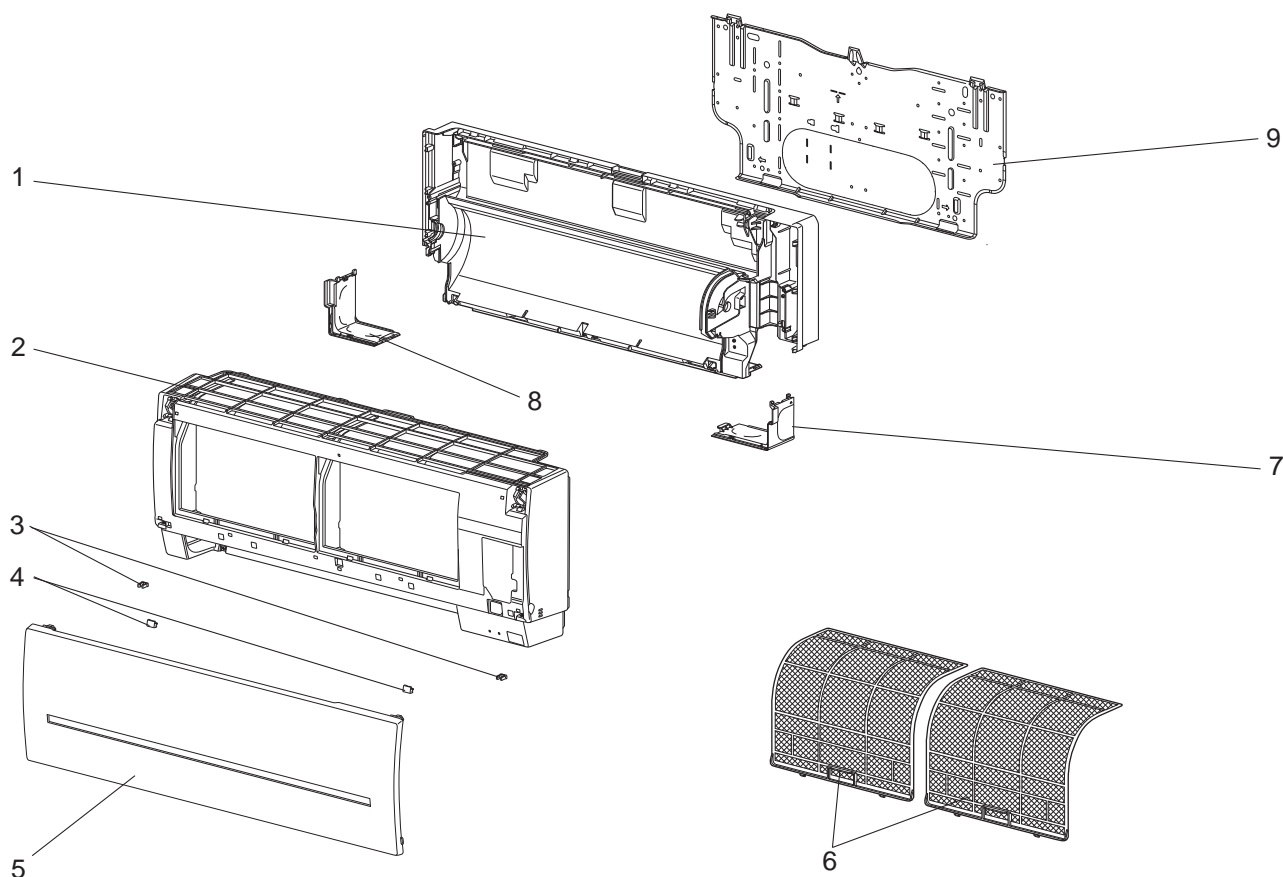

1-2. ACCESSORY AND REMOTE CONTROLLER

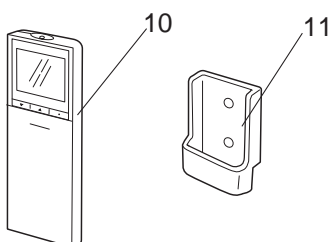

1-1. INDOOR UNIT STRUCTURAL PARTS

No.	Part No.	Part name	Symbol in Wiring Diagram	Q'ty/unit																Remarks
				MSZ-SF																
				25				35				42				50				
				VE -E1	VE -E2	VE -EN1	VE -EN2	VE -E1	VE -E2	VE -EN1	VE -EN2	VE -E1	VE -E2	VE -EN1	VE -EN2	VE -E1	VE -E2	VE -EN1	VE -EN2	
1	E12 H14 234	BOX ASSEMBLY		1	1	1	1	1	1	1	1	1	1	1	1	1	1	1	1	
2	E12 H14 000	PANEL ASSEMBLY		1	1	1	1	1	1	1	1	1	1	1	1	1	1	1	1	Includes No. 3, 4 and 5
3	E12 F95 142	CATCH		2	2	2	2	2	2	2	2	2	2	2	2	2	2	2	2	2 PCS/SET
4	E12 913 067	SCREW CAP		2	2	2	2	2	2	2	2	2	2	2	2	2	2	2	2	2 PCS/SET
5	E12 H14 010	FRONT PANEL		1	1	1	1	1	1	1	1	1	1	1	1	1	1	1	1	
6	E12 H14 100	AIR FILTER (NANO PLATINUM FILTER)		2	2	2	2	2	2	2	2	2	2	2	2	2	2	2	2	1 PC/SET
7	E12 H14 975	CORNER BOX RIGHT		1	1	1	1	1	1	1	1	1	1	1	1	1	1	1	1	
8	E12 H14 976	CORNER BOX LEFT		1	1	1	1	1	1	1	1	1	1	1	1	1	1	1	1	
9	E12 H14 970	INSTALLATION PLATE		1	1	1	1	1	1	1	1	1	1	1	1	1	1	1	1	

1-2. ACCESSORY AND REMOTE CONTROLLER

No.	Part No.	Part name	Symbol in Wiring Diagram	Q'ty/unit																Remarks
				MSZ-SF																
				25				35				42				50				
				VE -E1	VE -E2	VE -EN1	VE -EN2	VE -E1	VE -E2	VE -EN1	VE -EN2	VE -E1	VE -E2	VE -EN1	VE -EN2	VE -E1	VE -E2	VE -EN1	VE -EN2	
10	E12 F95 426	REMOTE CONTROLLER		1	1	1	1	1	1	1	1	1	1	1	1	1	1	1	1	SG11D
11	E12 F28 083	REMOTE CONTROLLER HOLDER		1	1	1	1	1	1	1	1	1	1	1	1	1	1	1	1	

MSZ-SF25VE- [E1], [E2], [EN1], [EN2]
 MSZ-SF42VE- [E1], [E2], [EN1], [EN2]

MSZ-SF35VE- [E1], [E2], [EN1], [EN2]
 MSZ-SF50VE- [E1], [E2], [EN1], [EN2]

1-3. INDOOR UNIT ELECTRICAL PARTS AND FUNCTIONAL PARTS

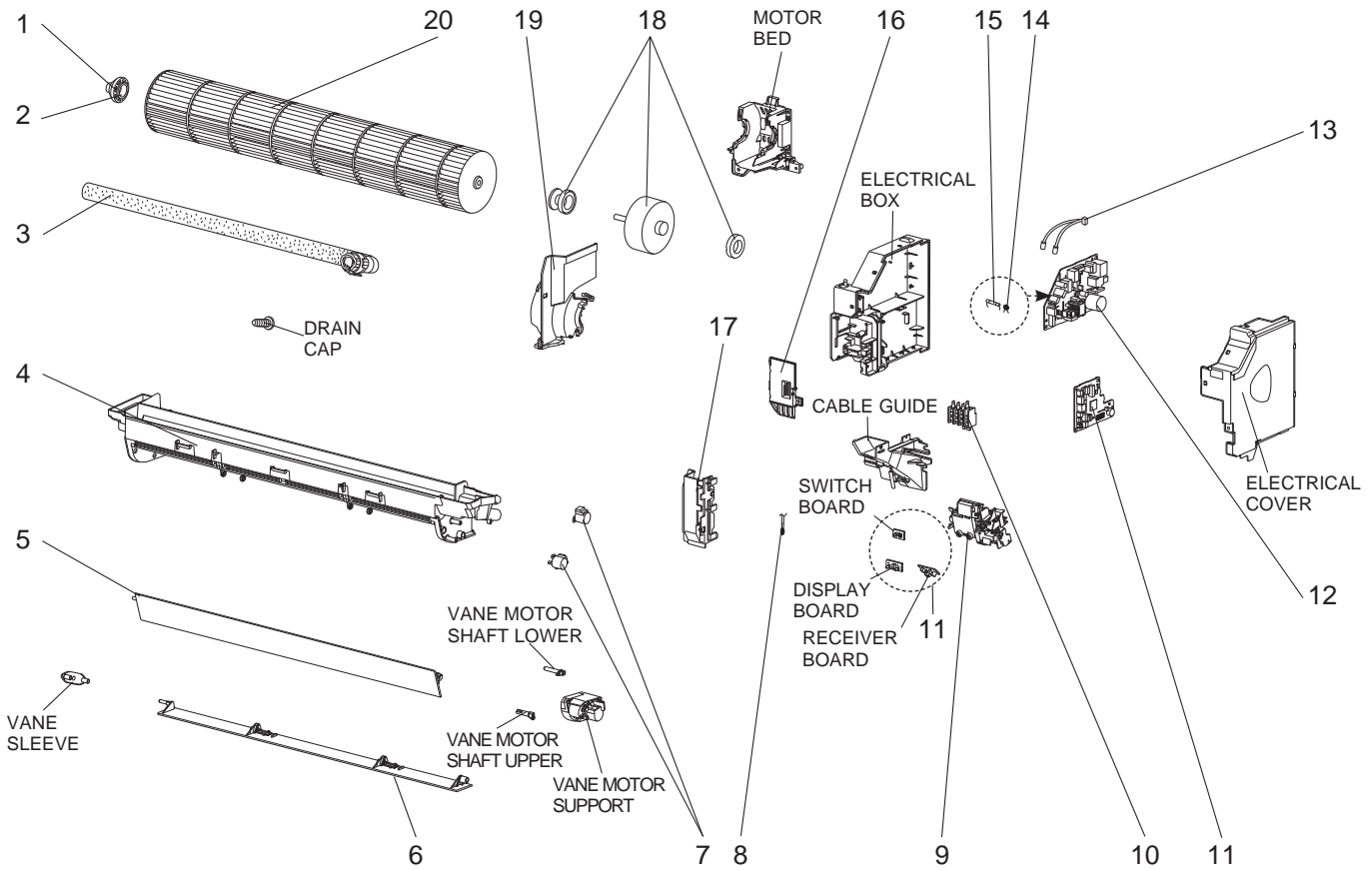

1-4. INDOOR UNIT HEAT EXCHANGER

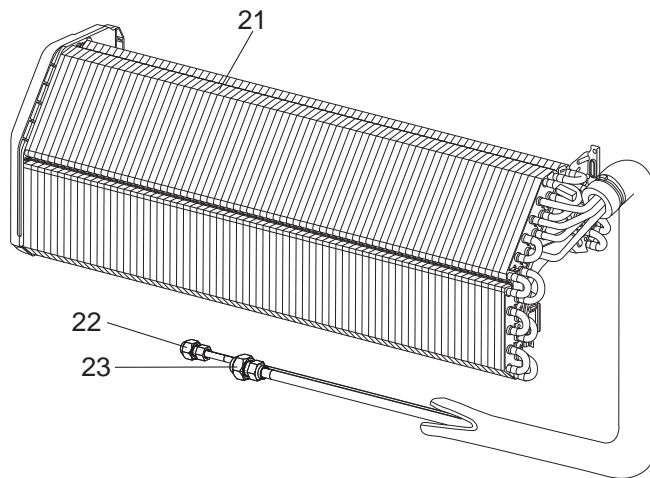

1-3. INDOOR UNIT ELECTRICAL PARTS AND FUNCTIONAL PARTS

No.	Part No.	Part name	Symbol in Wiring Diagram	Q'ty/unit																Remarks
				MSZ-SF																
				25				35				42				50				
VE	VE	VE	VE	VE	VE	VE	VE	VE	VE	VE	VE	VE	VE	VE	VE	VE	VE	VE	VE	
-E1	-E2	-EN1	-EN2	-E1	-E2	-EN1	-EN2	-E1	-E2	-EN1	-EN2	-E1	-E2	-EN1	-EN2	-E1	-E2	-EN1	-EN2	
1	E12 751 509	BEARING MOUNT		1	1	1	1	1	1	1	1	1	1	1	1	1	1	1	1	
2	E12 001 504	SLEEVE BEARING		1	1	1	1	1	1	1	1	1	1	1	1	1	1	1	1	
3	E12 897 702	DRAIN HOSE		1	1	1	1	1	1	1	1	1	1	1	1	1	1	1	1	
4	E12 H14 235	NOZZLE ASSEMBLY		1	1	1	1	1	1	1	1	1	1	1	1	1	1	1	1	
5	E12 H14 040	VANE UPPER		1	1	1	1	1	1	1	1	1	1	1	1	1	1	1	1	
6	E12 H14 041	VANE LOWER		1	1	1	1	1	1	1	1	1	1	1	1	1	1	1	1	
7	E12 A89 303	VANE MOTOR	MV	2	2	2	2	2	2	2	2	2	2	2	2	2	2	2	2	UP & DOWN, 1 PC/SET
8	E12 H14 308	ROOM TEMPERATURE THERMISTOR	RT11	1	1	1	1	1	1	1	1	1	1	1	1	1	1	1	1	
9	E12 H14 095	DISPLAY P.C. BOARD HOLDER ASSEMBLY		1	1	1	1	1	1	1	1	1	1	1	1	1	1	1	1	
10	E12 F95 375	TERMINAL BLOCK	TB	1	1	1	1	1	1	1	1	1	1	1	1	1	1	1	1	
11	E12 H14 452	ELECTRONIC CONTROL P.C. BOARD		1		1														Includes RECEIVER BOARD, DISPLAY BOARD and SWITCH BOARD.
	E12 J53 452				1		1													
	E12 H15 452							1		1										
	E12 J54 452									1		1								
	E12 H16 452												1		1					
	E12 J55 452															1		1		
	E12 H17 452																		1	
12	E12 H14 440	POWER P.C. BOARD		1		1						1		1						
	E12 J53 440				1		1					1		1						
	E12 H15 440							1		1						1		1		
	E12 J55 440									1							1	1		
13	E12 H14 307	INDOOR COIL THERMISTOR	RT12,RT13	1	1	1	1	1	1	1	1	1	1	1	1	1	1	1	1	
14	E12 B75 385	VARISTOR	NR11	1	1	1	1	1	1	1	1	1	1	1	1	1	1	1	1	
15	E12 A49 382	FUSE	F11	1	1	1	1	1	1	1	1	1	1	1	1	1	1	1	1	T3.15AL250V
16	E12 F95 784	V.A. CLAMP		1	1	1	1	1	1	1	1	1	1	1	1	1	1	1	1	
17	E12 H14 541	WATER CUT ASSEMBLY		1	1	1	1	1	1	1	1	1	1	1	1	1	1	1	1	
18	E12 H14 300	INDOOR FAN MOTOR	MF	1	1	1	1	1	1	1	1	1	1	1	1	1	1	1	1	RC0J21-□□ Includes FAN MOTOR RUBBER MOUNT (2 PCS/SET)
19	E12 F95 333	MOTOR BAND		1	1	1	1	1	1	1	1	1	1	1	1	1	1	1	1	
20	E12 H14 302	LINE FLOW FAN		1	1	1	1	1	1	1	1	1	1	1	1	1	1	1	1	

1-4. INDOOR UNIT HEAT EXCHANGER

No.	Part No.	Part name	Symbol in Wiring Diagram	Q'ty/unit																Remarks
				MSZ-SF																
				25				35				42				50				
VE	VE	VE	VE	VE	VE	VE	VE	VE	VE	VE	VE	VE	VE	VE	VE	VE	VE	VE	VE	
-E1	-E2	-EN1	-EN2	-E1	-E2	-EN1	-EN2	-E1	-E2	-EN1	-EN2	-E1	-E2	-EN1	-EN2	-E1	-E2	-EN1	-EN2	
21	E12 H14 620	INDOOR HEAT EXCHANGER		1	1			1	1			1	1							
	E12 H90 620					1	1			1	1			1	1					
	E12 H17 620															1	1			
	E12 H93 620																	1	1	
22	E12 151 667	UNION (LIQUID)		1	1	1	1	1	1	1	1	1	1	1	1	1	1	1	1	ø6.35
23	E12 815 666	UNION (GAS)		1	1	1	1	1	1	1	1	1	1	1	1					ø9.52
	E12 155 666															1	1	1	1	ø12.7

MSZ-SF25VE2- ,  MSZ-SF35VE2- , 
MSZ-SF42VE2- ,  MSZ-SF50VE2- , 

1-5. INDOOR UNIT STRUCTURAL PARTS

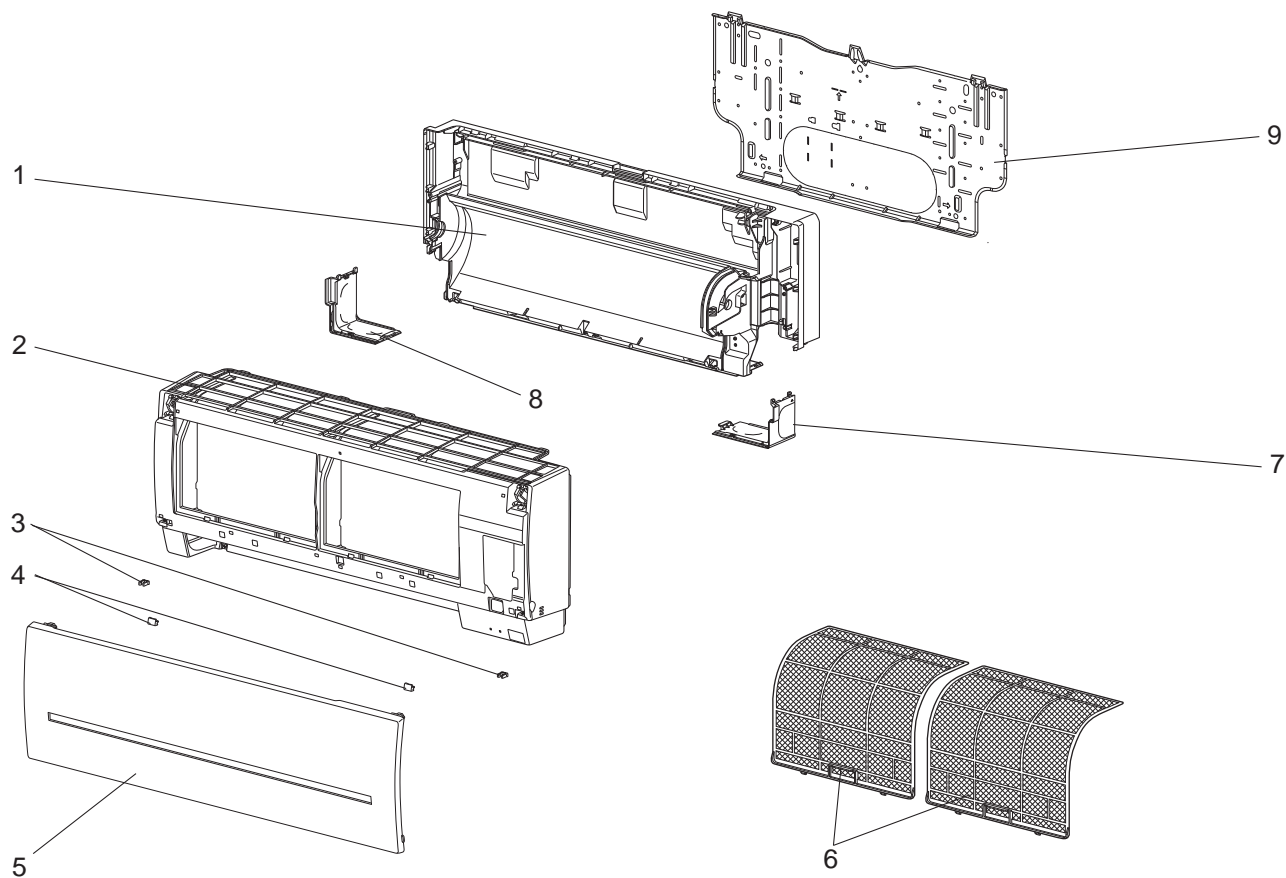

1-6. ACCESSORY AND REMOTE CONTROLLER

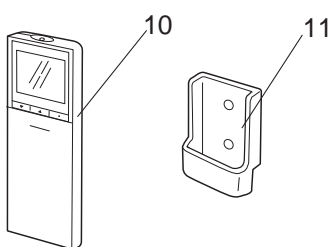

1-5. INDOOR UNIT STRUCTURAL PARTS

No.	Part No.	Part name	Symbol in Wiring Diagram	Q'ty/unit								Remarks
				MSZ-SF								
				25		35		42		50		
				VE2 -E1	VE2 -EN1	VE2 -E1	VE2 -EN1	VE2 -E1	VE2 -EN1	VE2 -E1	VE2 -EN1	
1	E12 H14 234	BOX ASSEMBLY		1	1	1	1	1	1	1	1	
2	E12 H14 000	PANEL ASSEMBLY		1	1	1	1	1	1	1	1	Includes No. 3, 4 and 5
3	E12 F95 142	CATCH		2	2	2	2	2	2	2	2	2 PCS/SET
4	E12 913 067	SCREW CAP		2	2	2	2	2	2	2	2	2 PCS/SET
5	E12 H14 010	FRONT PANEL		1	1	1	1	1	1	1	1	
6	E12 H14 100	AIR FILTER (NANO PLATINUM FILTER)		2	2	2	2	2	2	2	2	1 PC/SET
7	E12 H14 975	CORNER BOX RIGHT		1	1	1	1	1	1	1	1	
8	E12 H14 976	CORNER BOX LEFT		1	1	1	1	1	1	1	1	
9	E12 H14 970	INSTALLATION PLATE		1	1	1	1	1	1	1	1	

1-6. ACCESSORY AND REMOTE CONTROLLER

No.	Part No.	Part name	Symbol in Wiring Diagram	Q'ty/unit								Remarks
				MSZ-SF								
				25		35		42		50		
				VE2 -E1	VE2 -EN1	VE2 -E1	VE2 -EN1	VE2 -E1	VE2 -EN1	VE2 -E1	VE2 -EN1	
10	E12 M42 426	REMOTE CONTROLLER		1	1	1	1	1	1	1	1	SG14D
11	E12 F28 083	REMOTE CONTROLLER HOLDER		1	1	1	1	1	1	1	1	

MSZ-SF25VE2- E1, EN1 MSZ-SF35VE2- E1, EN1
 MSZ-SF42VE2- E1, EN1 MSZ-SF50VE2- E1, EN1

1-7. INDOOR UNIT ELECTRICAL PARTS AND FUNCTIONAL PARTS

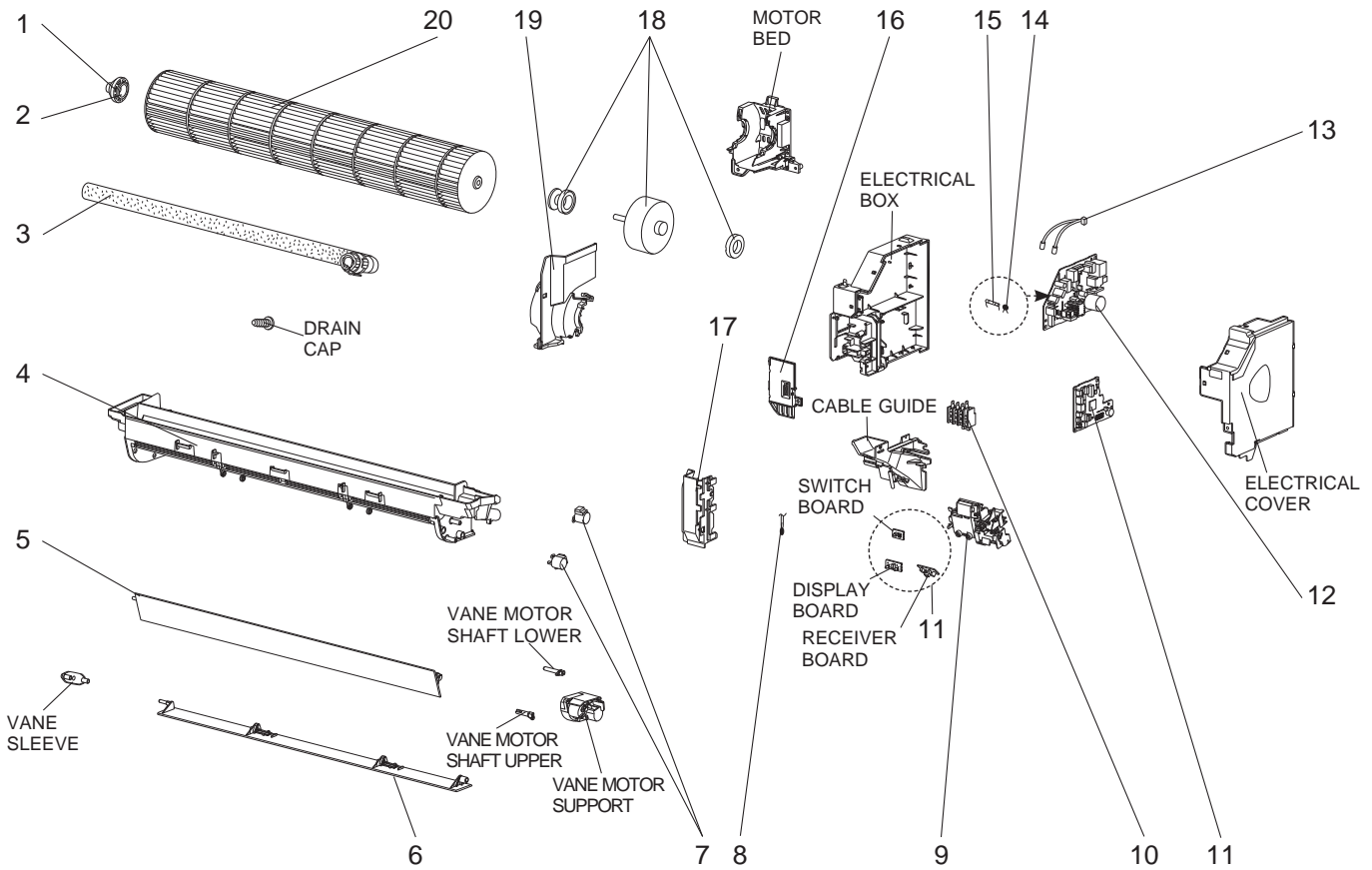

1-8. INDOOR UNIT HEAT EXCHANGER

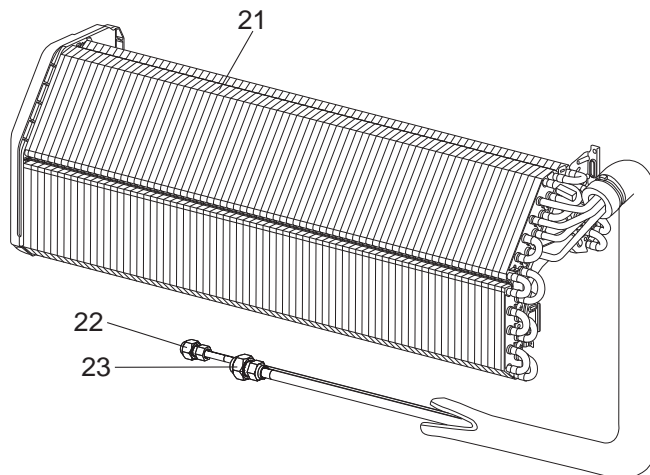

1-7. INDOOR UNIT ELECTRICAL PARTS AND FUNCTIONAL PARTS

No.	Part No.	Part name	Symbol in Wiring Diagram	Q'ty/unit								Remarks
				MSZ-SF								
				25		35		42		50		
				VE2 -E1	VE2 -EN1	VE2 -E1	VE2 -EN1	VE2 -E1	VE2 -EN1	VE2 -E1	VE2 -EN1	
1	E12 751 509	BEARING MOUNT		1	1	1	1	1	1	1	1	
2	E12 001 504	SLEEVE BEARING		1	1	1	1	1	1	1	1	
3	E12 897 702	DRAIN HOSE		1	1	1	1	1	1	1	1	
4	E12 H14 235	NOZZLE ASSEMBLY		1	1	1	1	1	1	1	1	
5	E12 H14 040	VANE UPPER		1	1	1	1	1	1	1	1	
6	E12 H14 041	VANE LOWER		1	1	1	1	1	1	1	1	
7	E12 A89 303	VANE MOTOR	MV	2	2	2	2	2	2	2	2	UP & DOWN, 1 PC/SET
8	E12 H14 308	ROOM TEMPERATURE THERMISTOR	RT11	1	1	1	1	1	1	1	1	
9	E12 H14 095	DISPLAY P.C. BOARD HOLDER ASSEMBLY		1	1	1	1	1	1	1	1	
10	E12 F95 375	TERMINAL BLOCK	TB	1	1	1	1	1	1	1	1	
11	E12 P83 452	ELECTRONIC CONTROL P.C. BOARD		1	1							Includes RECEIVER BOARD, DISPLAY BOARD and SWITCH BOARD.
	E12 P84 452					1	1					
	E12 P85 452							1	1			
	E12 P86 452									1	1	
12	E12 J53 440	POWER P.C. BOARD		1	1			1	1			
	E12 J55 440					1	1			1	1	
13	E12 H14 307	INDOOR COIL THERMISTOR	RT12, RT13	1	1	1	1	1	1	1	1	
14	E12 B75 385	VARISTOR	NR11	1	1	1	1	1	1	1	1	
15	E12 A49 382	FUSE	F11	1	1	1	1	1	1	1	1	T3.15AL250V
16	E12 F95 784	V.A. CLAMP		1	1	1	1	1	1	1	1	
17	E12 H14 541	WATER CUT ASSEMBLY		1	1	1	1	1	1	1	1	
18	E12 H14 300	INDOOR FAN MOTOR	MF	1	1	1	1	1	1	1	1	RC0J21-□□ Includes FAN MOTOR RUBBER MOUNT (2 PCS/SET)
19	E12 F95 333	MOTOR BAND		1	1	1	1	1	1	1	1	
20	E12 H14 302	LINE FLOW FAN		1	1	1	1	1	1	1	1	

1-8. INDOOR UNIT HEAT EXCHANGER

No.	Part No.	Part name	Symbol in Wiring Diagram	Q'ty/unit								Remarks
				MSZ-SF								
				25		35		42		50		
				VE2 -E1	VE2 -EN1	VE2 -E1	VE2 -EN1	VE2 -E1	VE2 -EN1	VE2 -E1	VE2 -EN1	
21	E12 H14 620	INDOOR HEAT EXCHANGER		1		1		1				
	E12 H90 620				1			1				
	E12 H17 620								1			
	E12 H93 620									1		
22	E12 151 667	UNION (LIQUID)		1	1	1	1	1	1	1	1	ø6.35
23	E12 815 666	UNION (GAS)		1	1	1	1	1	1			ø9.52
	E12 155 666								1	1	ø12.7	

MSZ-SF25VE-ER2

MSZ-SF35VE-ER2

MSZ-SF42VE-ER2

MSZ-SF50VE-ER2

MSZ-SF25VE2-ER1

MSZ-SF35VE2-ER1

MSZ-SF42VE2-ER1

MSZ-SF50VE2-ER1

1-9. INDOOR UNIT STRUCTURAL PARTS

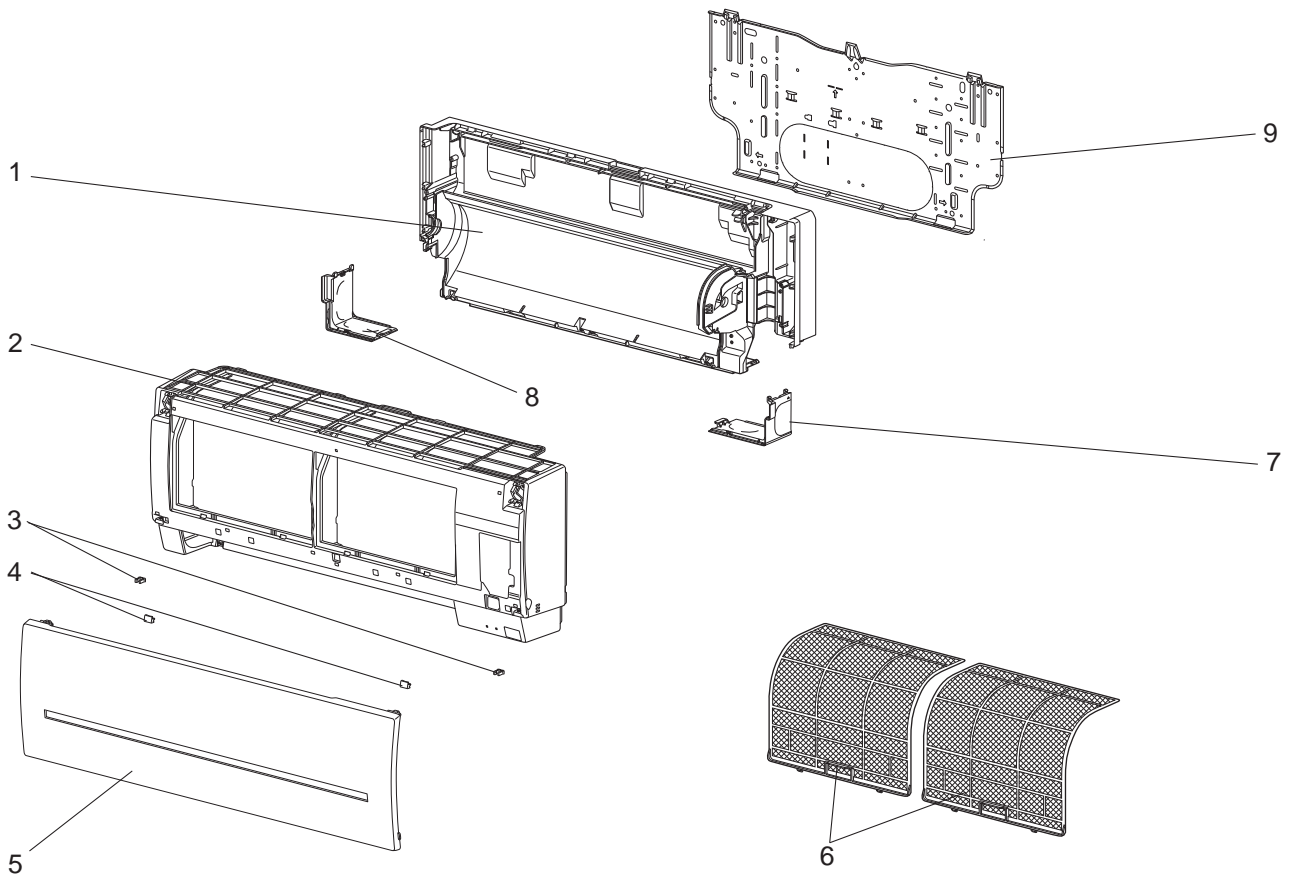

1-10. ACCESSORY AND REMOTE CONTROLLER

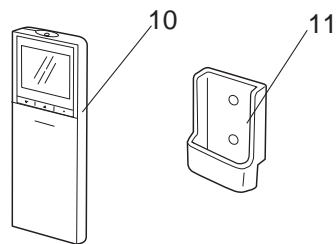

1-9. INDOOR UNIT STRUCTURAL PARTS

No.	Part No.	Part name	Symbol in Wiring Diagram	Q'ty/unit								Remarks
				MSZ-SF								
				25		35		42		50		
				VE -ER2	VE2 -ER1	VE -ER2	VE2 -ER1	VE -ER2	VE2 -ER1	VE -ER2	VE2 -ER1	
1	E12 H14 234	BOX ASSEMBLY		1	1	1	1	1	1	1	1	
2	E12 H14 000	PANEL ASSEMBLY		1	1	1	1	1	1	1	1	Includes No. 3, 4 and 5
3	E12 F95 142	CATCH		2	2	2	2	2	2	2	2	2 PCS/SET
4	E12 913 067	SCREW CAP		2	2	2	2	2	2	2	2	2 PCS/SET
5	E12 H14 010	FRONT PANEL		1	1	1	1	1	1	1	1	
6	E12 H14 100	AIR FILTER (NANO PLATINUM FILTER)		2	2	2	2	2	2	2	2	1 PC/SET
7	E12 H14 975	CORNER BOX RIGHT		1	1	1	1	1	1	1	1	
8	E12 H14 976	CORNER BOX LEFT		1	1	1	1	1	1	1	1	
9	E12 H14 970	INSTALLATION PLATE		1	1	1	1	1	1	1	1	

1-10. ACCESSORY AND REMOTE CONTROLLER

No.	Part No.	Part name	Symbol in Wiring Diagram	Q'ty/unit								Remarks
				MSZ-SF								
				25		35		42		50		
				VE -ER2	VE2 -ER1	VE -ER2	VE2 -ER1	VE -ER2	VE2 -ER1	VE -ER2	VE2 -ER1	
10	E12 F95 426	REMOTE CONTROLLER		1		1		1		1		SG11D
	E12 M42 426				1		1		1		1	SG14D
11	E12 F28 083	REMOTE CONTROLLER HOLDER		1	1	1	1	1	1	1	1	

MSZ-SF25VE-ER2

MSZ-SF35VE-ER2

MSZ-SF42VE-ER2

MSZ-SF50VE-ER2

MSZ-SF25VE2-ER1

MSZ-SF35VE2-ER1

MSZ-SF42VE2-ER1

MSZ-SF50VE2-ER1

1-11. INDOOR UNIT ELECTRICAL PARTS AND FUNCTIONAL PARTS

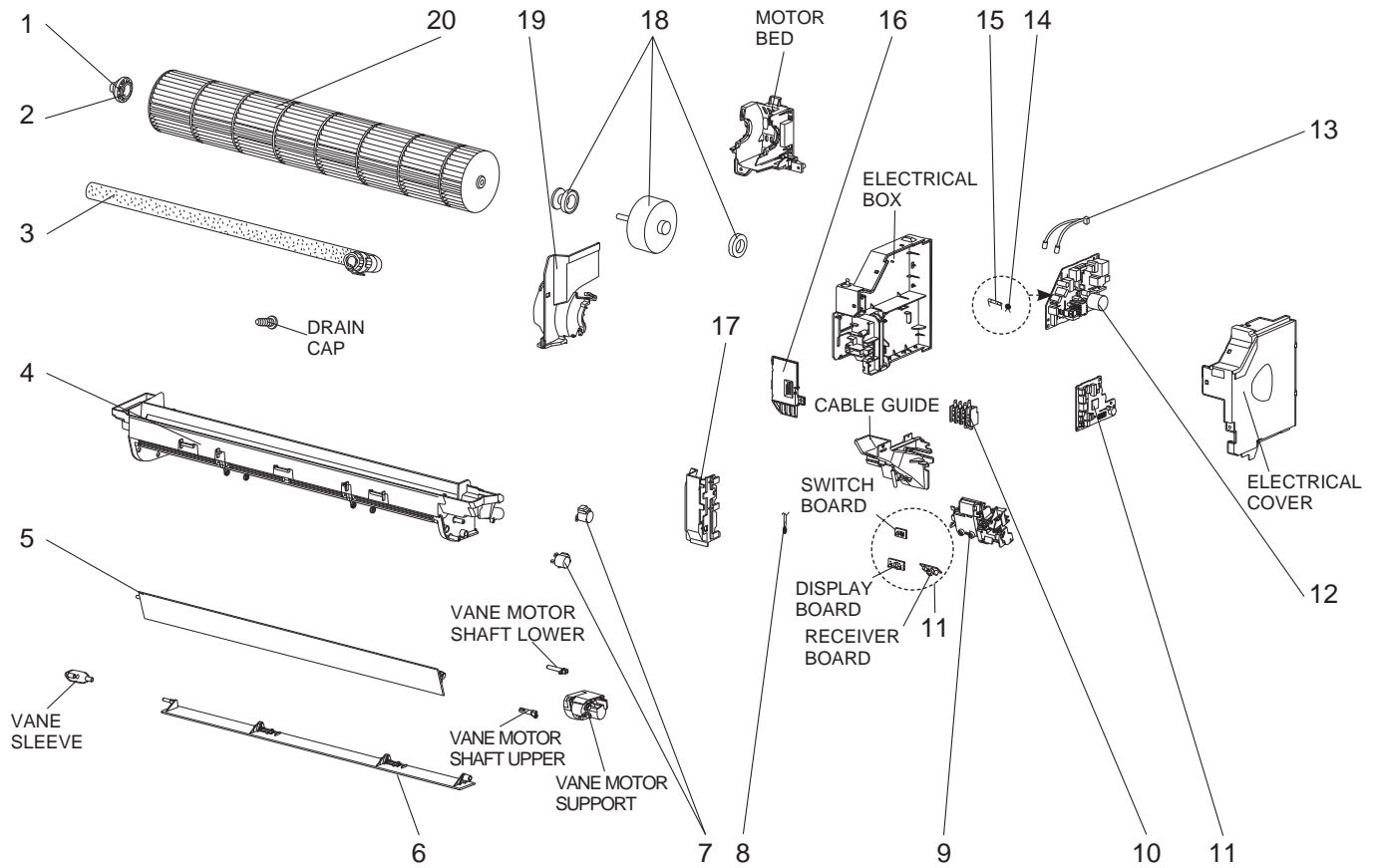

1-12. INDOOR UNIT HEAT EXCHANGER

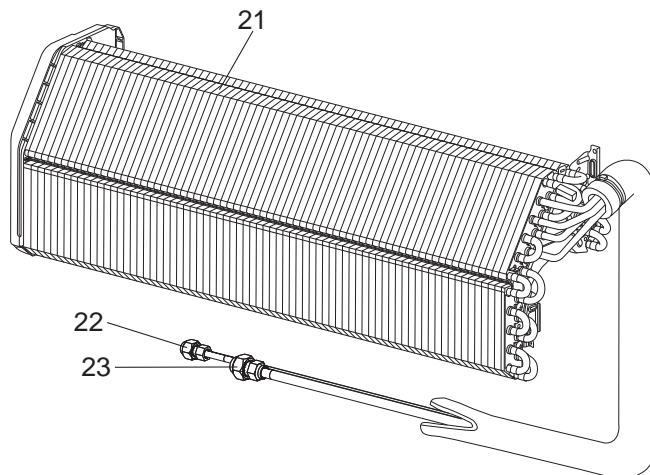

1-11. INDOOR UNIT ELECTRICAL PARTS AND FUNCTIONAL PARTS

No.	Part No.	Part name	Symbol in Wiring Diagram	Q'ty/unit								Remarks
				MSZ-SF								
				25		35		42		50		
				VE -ER2	VE2 -ER1	VE -ER2	VE2 -ER1	VE -ER2	VE2 -ER1	VE -ER2	VE2 -ER1	
1	E12 751 509	BEARING MOUNT		1	1	1	1	1	1	1	1	
2	E12 001 504	SLEEVE BEARING		1	1	1	1	1	1	1	1	
3	E12 897 702	DRAIN HOSE		1	1	1	1	1	1	1	1	
4	E12 H14 235	NOZZLE ASSEMBLY		1	1	1	1	1	1	1	1	
5	E12 H14 040	VANE UPPER		1	1	1	1	1	1	1	1	
6	E12 H14 041	VANE LOWER		1	1	1	1	1	1	1	1	
7	E12 A89 303	VANE MOTOR	MV	2	2	2	2	2	2	2	2	UP & DOWN, 1 PC/SET
8	E12 H14 308	ROOM TEMPERATURE THERMISTOR	RT11	1	1	1	1	1	1	1	1	
9	E12 H14 095	DISPLAY P.C. BOARD HOLDER ASSEMBLY		1	1	1	1	1	1	1	1	
10	E12 F95 375	TERMINAL BLOCK	TB	1	1	1	1	1	1	1	1	
11	E12 J53 452	ELECTRONIC CONTROL P.C. BOARD		1								Includes RECEIVER BOARD, DISPLAY BOARD and SWITCH BOARD.
				1								
					1							
						1						
							1					
									1			
										1		
12	E12 J53 440	POWER P.C. BOARD		1	1			1	1			
	E12 J55 440					1	1			1	1	
13	E12 H14 307	INDOOR COIL THERMISTOR	RT12, RT13	1	1	1	1	1	1	1	1	
14	E12 B75 385	VARIATOR	NR11	1	1	1	1	1	1	1	1	
15	E12 A49 382	FUSE	F11	1	1	1	1	1	1	1	1	T3.15AL250V
16	E12 F95 784	V.A. CLAMP		1	1	1	1	1	1	1	1	
17	E12 H14 541	WATER CUT ASSEMBLY		1	1	1	1	1	1	1	1	
18	E12 H14 300	INDOOR FAN MOTOR	MF	1	1	1	1	1	1	1	1	RC0J21-□□ Includes FAN MOTOR RUBBER MOUNT (2 PCS/SET)
19	E12 F95 333	MOTOR BAND		1	1	1	1	1	1	1	1	
20	E12 H14 302	LINE FLOW FAN		1	1	1	1	1	1	1	1	

1-12. INDOOR UNIT HEAT EXCHANGER

No.	Part No.	Part name	Symbol in Wiring Diagram	Q'ty/unit								Remarks
				MSZ-SF								
				25		35		42		50		
				VE -ER2	VE2 -ER1	VE -ER2	VE2 -ER1	VE -ER2	VE2 -ER1	VE -ER2	VE2 -ER1	
21	E12 H14 620	INDOOR HEAT EXCHANGER		1	1	1	1	1	1			
	E12 H17 620								1	1		
22	E12 151 667	UNION (LIQUID)		1	1	1	1	1	1	1	1	ø6.35
23	E12 815 666	UNION (GAS)		1	1	1	1	1	1			ø9.52
	E12 155 666								1	1		ø12.7

MSZ-SF25VE3- E1, EN1 MSZ-SF35VE3- E1, EN1
MSZ-SF42VE3- E1, EN1 MSZ-SF50VE3- E1, EN1

1-13. INDOOR UNIT STRUCTURAL PARTS

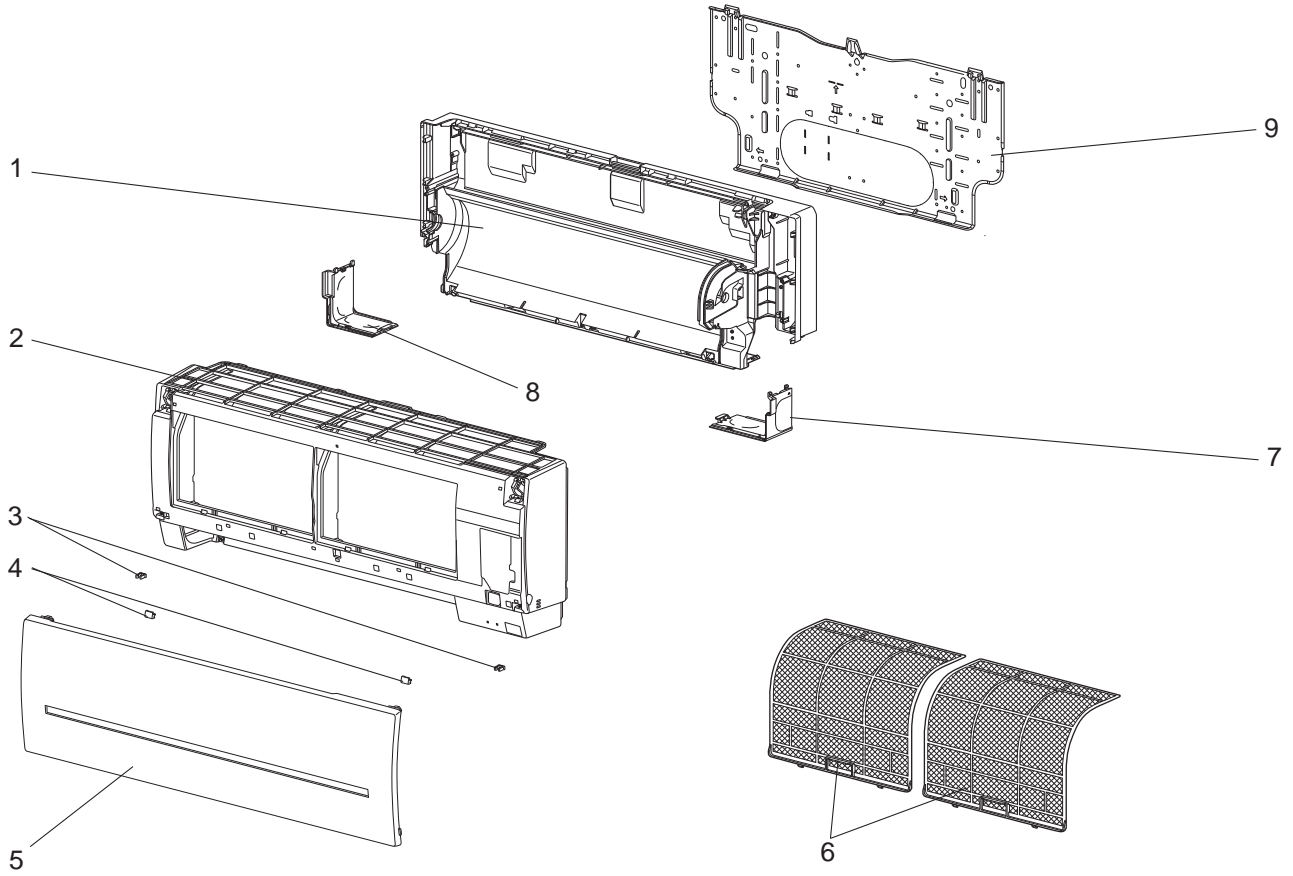

1-14. ACCESSORY AND REMOTE CONTROLLER

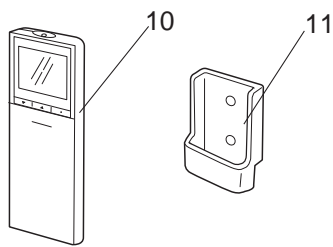

1-13. INDOOR UNIT STRUCTURAL PARTS

No.	Part No.	Part name	Symbol in Wiring Diagram	Q'ty/unit								Remarks
				MSZ-SF								
				25		35		42		50		
				VE3 -E1	VE3 -EN1	VE3 -E1	VE3 -EN1	VE3 -E1	VE3 -EN1	VE3 -E1	VE3 -EN1	
1	E22 H14 234	BOX ASSEMBLY		1	1	1	1	1	1	1	1	
2	E22 W74 000	PANEL ASSEMBLY		1	1	1	1	1	1	1	1	Includes No. 3, 4 and 5
3	E22 F95 142	CATCH		2	2	2	2	2	2	2	2	2 PCS/SET
4	E22 913 067	SCREW CAP		2	2	2	2	2	2	2	2	2 PCS/SET
5	E22 W74 010	FRONT PANEL		1	1	1	1	1	1	1	1	
6	E22 W74 100	AIR PURIFYING FILTER		2	2	2	2	2	2	2	2	1 PC/SET
7	E22 H14 975	CORNER BOX RIGHT		1	1	1	1	1	1	1	1	
8	E22 H14 976	CORNER BOX LEFT		1	1	1	1	1	1	1	1	
9	E22 H14 970	INSTALLATION PLATE		1	1	1	1	1	1	1	1	

1-14. ACCESSORY AND REMOTE CONTROLLER

No.	Part No.	Part name	Symbol in Wiring Diagram	Q'ty/unit								Remarks
				MSZ-SF								
				25		35		42		50		
				VE3 -E1	VE3 -EN1	VE3 -E1	VE3 -EN1	VE3 -E1	VE3 -EN1	VE3 -E1	VE3 -EN1	
10	E22 R80 426	REMOTE CONTROLLER		1	1	1	1	1	1	1	1	SG15D
11	E22 F28 083	REMOTE CONTROLLER HOLDER		1	1	1	1	1	1	1	1	

MSZ-SF25VE3- E1, EN1 MSZ-SF35VE3- E1, EN1
 MSZ-SF42VE3- E1, EN1 MSZ-SF50VE3- E1, EN1

1-15. INDOOR UNIT ELECTRICAL PARTS AND FUNCTIONAL PARTS

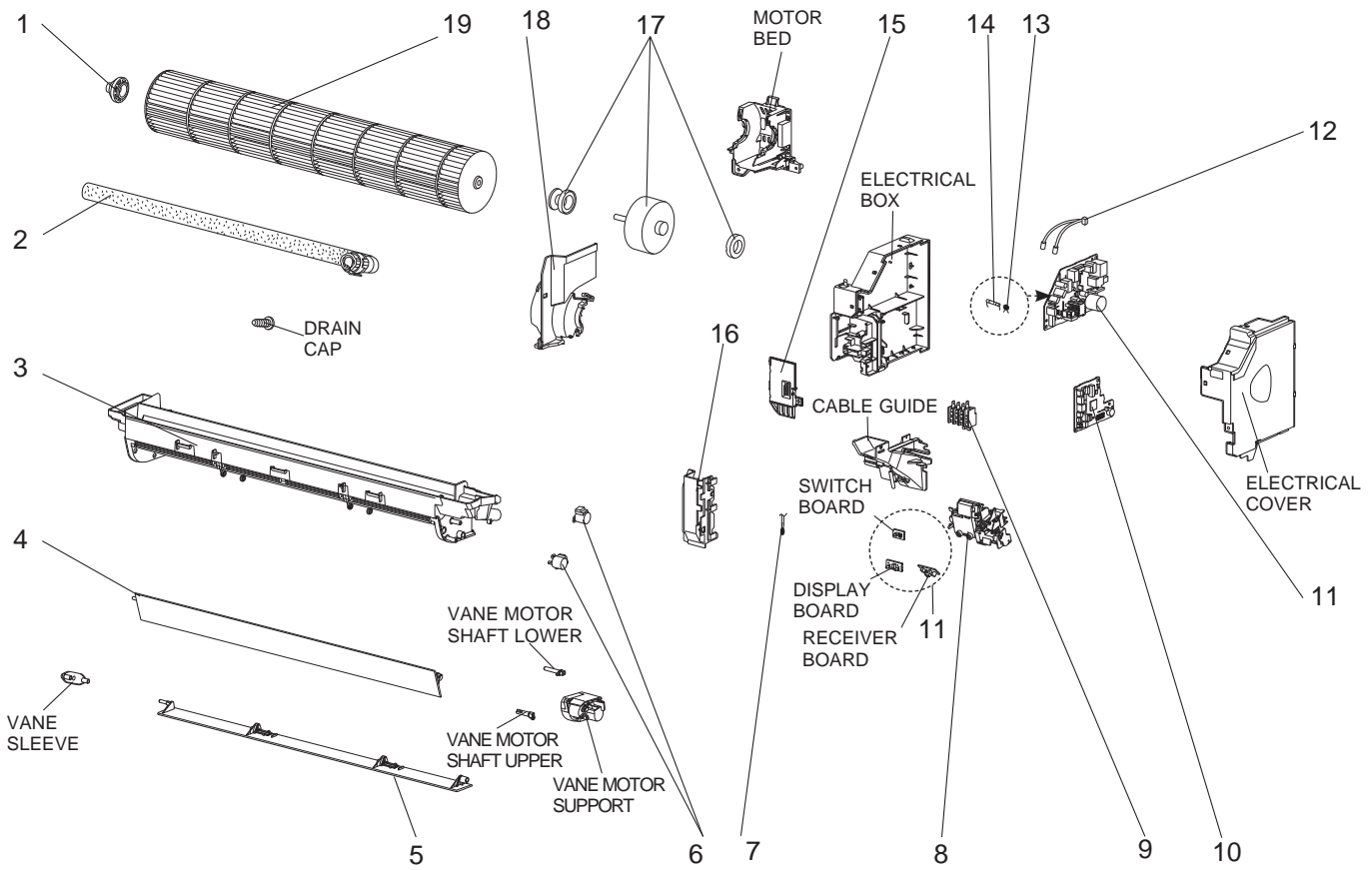

1-16. INDOOR UNIT HEAT EXCHANGER

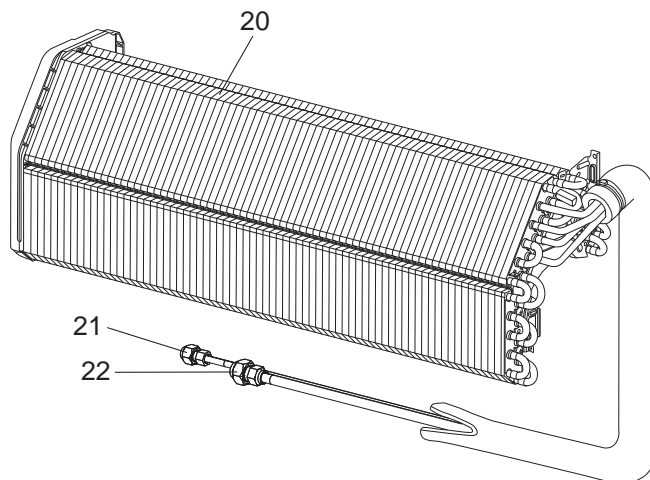

1-15. INDOOR UNIT ELECTRICAL PARTS AND FUNCTIONAL PARTS

No.	Part No.	Part name	Symbol in Wiring Diagram	Q'ty/unit								Remarks
				MSZ-SF								
				25		35		42		50		
				VE3 -E1	VE3 -EN1	VE3 -E1	VE3 -EN1	VE3 -E1	VE3 -EN1	VE3 -E1	VE3 -EN1	
1	E22 A89 509	BEARING MOUNT		1	1	1	1	1	1	1	1	Includes SLEEVE BEARING
2	E22 P72 702	DRAIN HOSE		1	1	1	1	1	1	1	1	
3	E22 H14 235	NOZZLE ASSEMBLY		1	1	1	1	1	1	1	1	
4	E22 H14 040	VANE UPPER		1	1	1	1	1	1	1	1	
5	E22 H14 041	VANE LOWER		1	1	1	1	1	1	1	1	
6	E22 A89 303	VANE MOTOR	MV	2	2	2	2	2	2	2	2	UP & DOWN, 1 PC/SET
7	E22 H14 308	ROOM TEMPERATURE THERMISTOR	RT11	1	1	1	1	1	1	1	1	
8	E22 H14 095	DISPLAY P.C. BOARD HOLDER ASSEMBLY		1	1	1	1	1	1	1	1	
9	E22 T21 375	TERMINAL BLOCK	TB	1	1	1	1	1	1	1	1	
10	E22 P83 452	ELECTRONIC CONTROL P.C. BOARD		1	1							Includes RECEIVER BOARD, DISPLAY BOARD and SWITCH BOARD.
					1	1						
							1	1				
									1	1		
11	E22 J53 440	POWER P.C. BOARD		1	1			1	1			
	E22 J55 440					1	1			1	1	
12	E22 H14 307	INDOOR COIL THERMISTOR	RT12, RT13	1	1	1	1	1	1	1	1	
	E22 B75 385	VARISTOR	NR11	1	1	1	1	1	1	1	1	
13	E22 A49 382	FUSE	F11	1	1	1	1	1	1	1	1	T3.15AL250V
14	E22 F95 784	V.A. CLAMP		1	1	1	1	1	1	1	1	
15	E22 H14 541	WATER CUT ASSEMBLY		1	1	1	1	1	1	1	1	
16	E22 H14 300	INDOOR FAN MOTOR	MF	1	1	1	1	1	1	1	1	RC0J21-□□ Includes FAN MOTOR RUBBER MOUNT (2 PCS/SET)
18	E22 F95 333	MOTOR BAND		1	1	1	1	1	1	1	1	
19	E22 H14 302	LINE FLOW FAN		1	1	1	1	1	1	1	1	

1-16. INDOOR UNIT HEAT EXCHANGER

No.	Part No.	Part name	Symbol in Wiring Diagram	Q'ty/unit								Remarks
				MSZ-SF								
				25		35		42		50		
				VE3 -E1	VE3 -EN1	VE3 -E1	VE3 -EN1	VE3 -E1	VE3 -EN1	VE3 -E1	VE3 -EN1	
20	E22 H14 620	INDOOR HEAT EXCHANGER		1	1	1	1	1	1			
	E22 H17 620								1	1		
21	E22 151 667	UNION (LIQUID)		1	1	1	1	1	1	1	1	ø6.35
22	E22 815 666	UNION (GAS)		1	1	1	1	1	1			ø9.52
	E22 155 666								1	1	ø12.7	

MSZ-SF25VE3-ER1 MSZ-SF35VE3-ER1 MSZ-SF42VE3-ER1 MSZ-SF50VE3-ER1

1-17. INDOOR UNIT STRUCTURAL PARTS

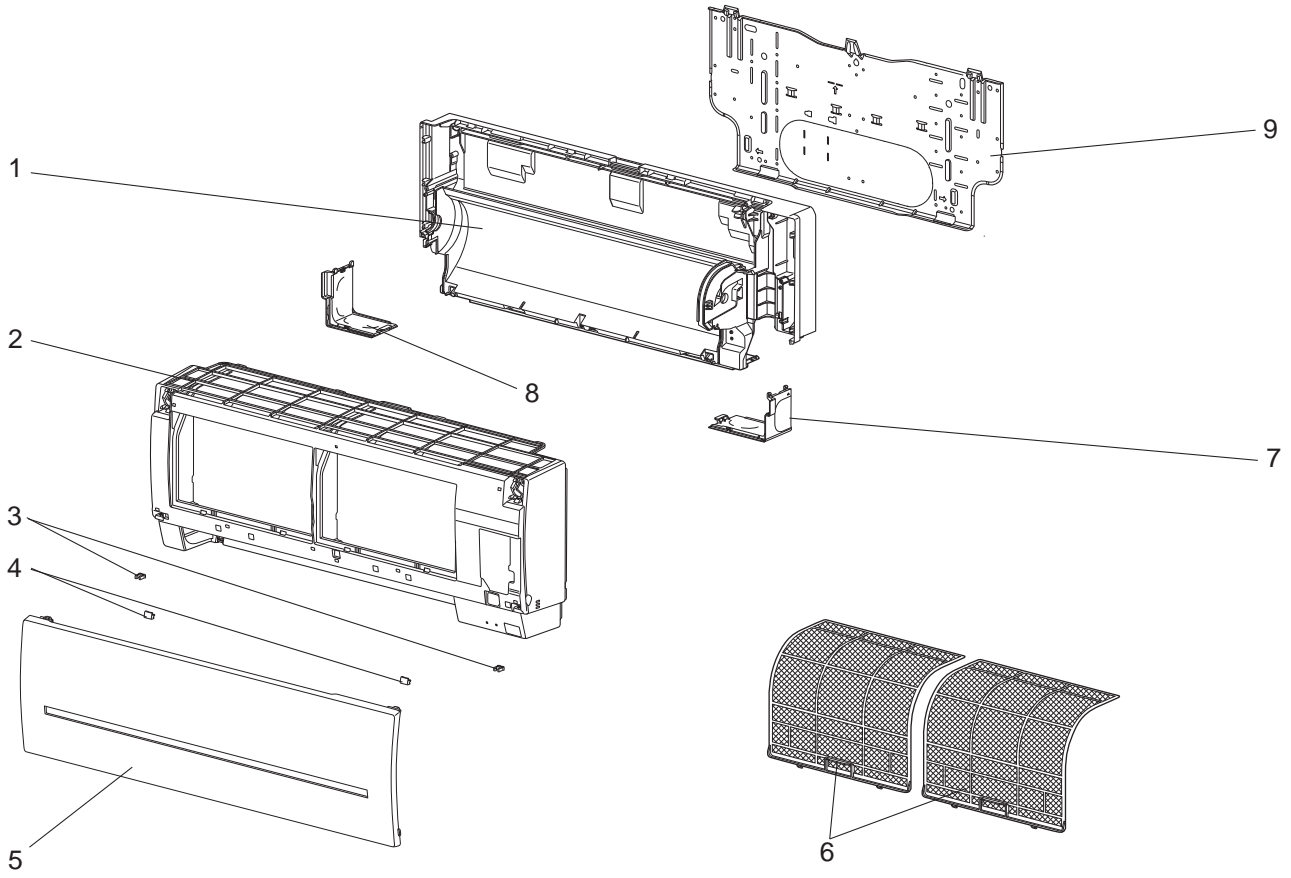

1-18. ACCESSORY AND REMOTE CONTROLLER

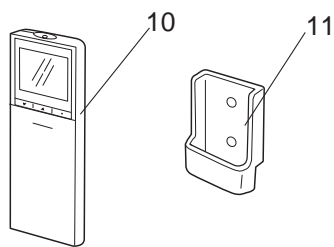

1-17. INDOOR UNIT STRUCTURAL PARTS

No.	Part No.	Part name	Symbol in Wiring Diagram	Q'ty/unit				Remarks
				MSZ-SF				
				25	35	42	50	
				VE3-ER1	VE3-ER1	VE3-ER1	VE3-ER1	
1	E22 H14 234	BOX ASSEMBLY		1	1	1	1	
2	E22 W82 000	PANEL ASSEMBLY		1	1	1	1	Includes No. 3, 4 and 5
3	E22 F95 142	CATCH		2	2	2	2	2 PCS/SET
4	E22 913 067	SCREW CAP		2	2	2	2	2 PCS/SET
5	E22 W74 010	FRONT PANEL		1	1	1	1	
6	E22 W74 100	AIR PURIFYING FILTER		2	2	2	2	1 PC/SET
7	E22 H14 975	CORNER BOX RIGHT		1	1	1	1	
8	E22 H14 976	CORNER BOX LEFT		1	1	1	1	
9	E22 H14 970	INSTALLATION PLATE		1	1	1	1	

1-18. ACCESSORY AND REMOTE CONTROLLER

No.	Part No.	Part name	Symbol in Wiring Diagram	Q'ty/unit				Remarks
				MSZ-SF				
				25	35	42	50	
				VE3-ER1	VE3-ER1	VE3-ER1	VE3-ER1	
10	E22 R80 426	REMOTE CONTROLLER		1	1	1	1	SG15D
11	E22 F28 083	REMOTE CONTROLLER HOLDER		1	1	1	1	

MSZ-SF25VE3-ER1 MSZ-SF35VE3-ER1 MSZ-SF42VE3-ER1 MSZ-SF50VE3-ER1

1-19. INDOOR UNIT ELECTRICAL PARTS AND FUNCTIONAL PARTS

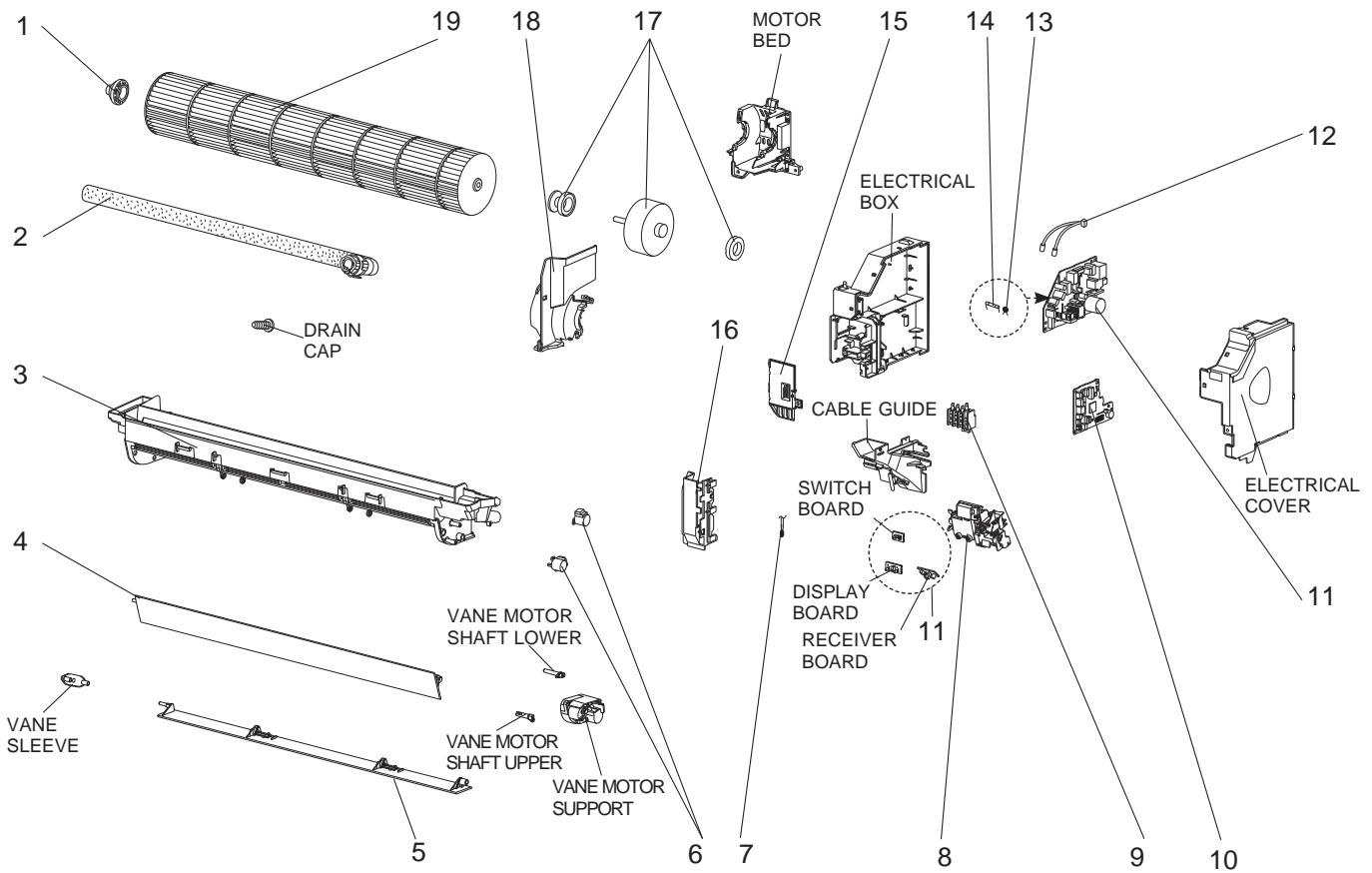

1-20. INDOOR UNIT HEAT EXCHANGER

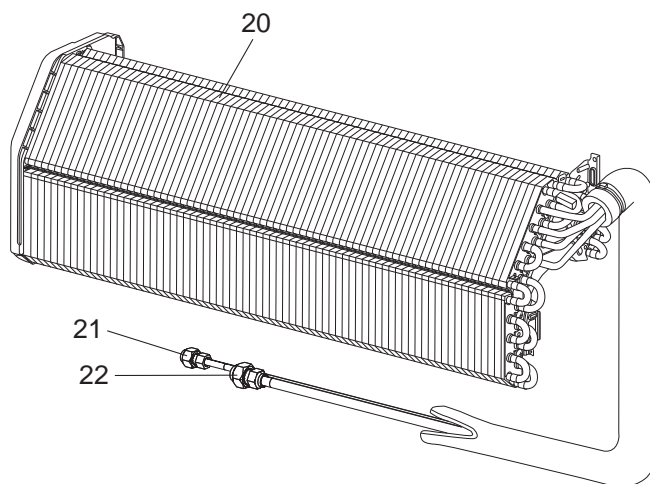

1-19. INDOOR UNIT ELECTRICAL PARTS AND FUNCTIONAL PARTS

No.	Part No.	Part name	Symbol in Wiring Diagram	Q'ty/unit				Remarks
				MSZ-SF				
				25	35	42	50	
VE3-ER1	VE3-ER1	VE3-ER1	VE3-ER1					
1	E22 A89 509	BEARING MOUNT		1	1	1	1	Includes SLEEVE BEARING
2	E22 P72 702	DRAIN HOSE		1	1	1	1	
3	E22 H14 235	NOZZLE ASSEMBLY		1	1	1	1	
4	E22 H14 040	VANE UPPER		1	1	1	1	
5	E22 H14 041	VANE LOWER		1	1	1	1	
6	E22 A89 303	VANE MOTOR	MV	2	2	2	2	UP & DOWN, 1 PC/SET
7	E22 H14 308	ROOM TEMPERATURE THERMISTOR	RT11	1	1	1	1	
8	E22 H14 095	DISPLAY P.C. BOARD HOLDER ASSEMBLY		1	1	1	1	
9	E22 T21 375	TERMINAL BLOCK	TB	1	1	1	1	
10	E22 P83 452	ELECTRONIC CONTROL P.C. BOARD		1				Includes RECEIVER BOARD, DISPLAY BOARD and SWITCH BOARD.
	E22 P84 452				1			
	E22 P85 452					1		
	E22 P86 452						1	
11	E22 J53 440	POWER P.C. BOARD		1		1		
	E22 J55 440				1		1	
12	E22 H14 307	INDOOR COIL THERMISTOR	RT12, RT13	1	1	1	1	
13	E22 B75 385	VARISTOR	NR11	1	1	1	1	
14	E22 A49 382	FUSE	F11	1	1	1	1	T3.15AL250V
15	E22 F95 784	V.A. CLAMP		1	1	1	1	
16	E22 H14 541	WATER CUT ASSEMBLY		1	1	1	1	
17	E22 H14 300	INDOOR FAN MOTOR	MF	1	1	1	1	RC0J21-□□ Includes FAN MOTOR RUBBER MOUNT (2 PCS/SET)
18	E22 F95 333	MOTOR BAND		1	1	1	1	
19	E22 H14 302	LINE FLOW FAN		1	1	1	1	

1-20. INDOOR UNIT HEAT EXCHANGER

No.	Part No.	Part name	Symbol in Wiring Diagram	Q'ty/unit				Remarks
				MSZ-SF				
				25	35	42	50	
VE3-ER1	VE3-ER1	VE3-ER1	VE3-ER1					
20	E22 H14 620	INDOOR HEAT EXCHANGER		1	1	1		
	E22 H17 620						1	
21	E22 151 667	UNION (LIQUID)		1	1	1	1	ø6.35
22	E22 815 666	UNION (GAS)		1	1	1		ø9.52
	E22 155 666						1	ø12.7

2-1. AIR CLEANING FILTER

(ELECTROSTATIC ANTI-ALLERGY ENZYME FILTER: MSZ-SF·VE, MSZ-SF·VE2)

(SILVER-IONIZED AIR PURIFIER FILTER: MSZ-SF·VE3)

Every 3 months:

- Remove dirt by a vacuum cleaner.

When dirt cannot be removed by vacuum cleaning:

- Soak the filter and its frame in lukewarm water before rinsing it.
- After washing, dry it well in shade. Install all tabs of the air filter.

Every year:

- Replace it with a new air cleaning filter for best performance.

NOTE 1: Clean the filters regularly for best performance and to reduce power consumption.

NOTE 2: Dirty filters cause condensation in the air conditioner which will contribute to the growth of fungi such as mold. It is therefore recommended to clean air filters every 2 weeks.

Model	Part No.
MSZ-SF25VE MSZ-SF35VE MSZ-SF42VE MSZ-SF50VE MSZ-SF25VE2 MSZ-SF35VE2 MSZ-SF42VE2 MSZ-SF50VE2	MAC-2320FT
MSZ-SF25VE3 MSZ-SF35VE3 MSZ-SF42VE3 MSZ-SF50VE3	MAC-2370FT-E

Pull to remove from the air filter

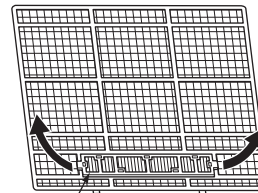

Air cleaning filter
MSZ-SF·VE, MSZ-SF·VE2
(Electrostatic anti-allergy enzyme filter)
MSZ-SF·VE3
(Silver-ionized air purifier filter)

MITSUBISHI ELECTRIC CORPORATION

HEAD OFFICE: TOKYO BUILDING, 2-7-3, MARUNOUCHI, CHIYODA-KU, TOKYO 100-8310, JAPAN

© Copyright 2011 MITSUBISHI ELECTRIC CORPORATION

Issued: Oct. 2019. No.OBB600 REVISED EDITION-F

Issued: Jan. 2016. No.OBB600 REVISED EDITION-E

Issued: Nov. 2014. No.OBB600 REVISED EDITION-D

Issued: Dec. 2013. No.OBB600 REVISED EDITION-C

Issued: Nov. 2012. No.OBB600 REVISED EDITION-B

Issued: Jan. 2012. No.OBB600 REVISED EDITION-A

Published: Nov. 2011. No.OBB600

Made in Japan

Specifications are subject to change without notice.