

## INDOOR UNIT

No. OBB801

# PARTS CATALOG

### Models

**MLZ-KP25VF** - **E1**, **ER1**

**MLZ-KP35VF** - **E1**, **ER1**

**MLZ-KP50VF** - **E1**, **ER1**

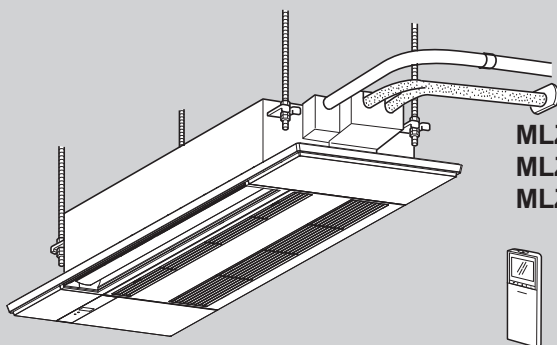

MLZ-KP25VF  
MLZ-KP35VF  
MLZ-KP50VF

### CONTENTS

1. RoHS PARTS LIST..... 2
2. OPTIONAL PARTS..... 6

**SERVICE MANUAL (OBH801)**

**NOTE:**

RoHS compliant products have <G> mark on the spec name plate.

## MLZ-KP25VF MLZ-KP35VF MLZ-KP50VF

## 1-1. INDOOR UNIT STRUCTURAL PARTS AND FUNCTIONAL PARTS

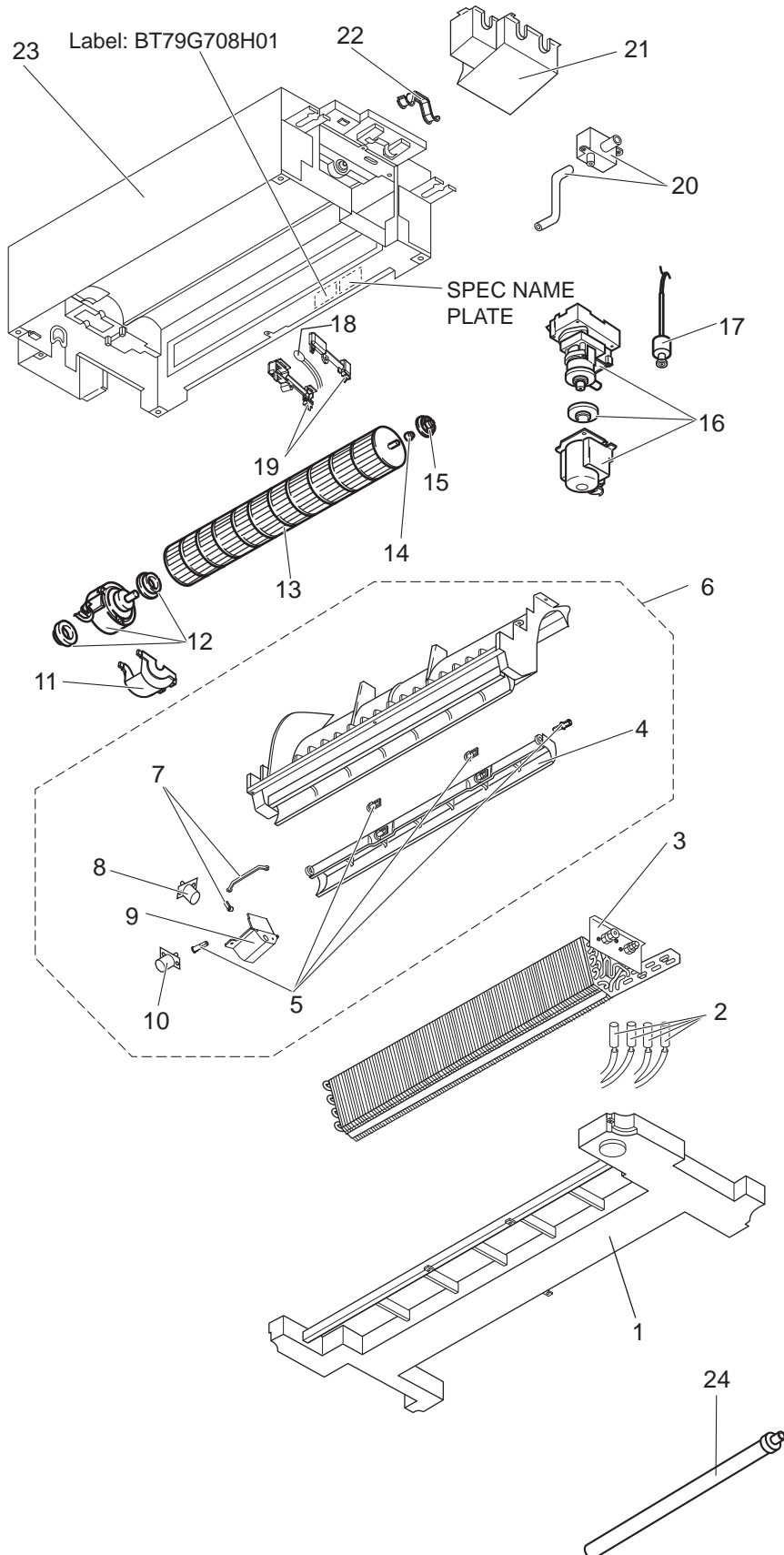

# RoHS PARTS LIST

## 1-1. INDOOR UNIT STRUCTURAL PARTS AND FUNCTIONAL PARTS

No.	RoHS	Part No.	Part Name	Symbol in Wiring Diagram	Q'ty/unit						Remarks
					MLZ-KP						
					25VF -		35VF -		50VF -		
					E1	ER1	E1	ER1	E1	ER1	
1	G	M21 EA4 700	DRAIN PAN		1	1	1	1	1	1	
2	G	M21 EAP 307	INDOOR COIL THERMISTOR	RT12,13	1	1	1	1			
	G	M21 EAS 307		RT12,13,14					1	1	
	G	M21 EAR 307		RT15					1	1	
3	G	M21 EGC 620	INDOOR HEAT EXCHANGER		1	1	1	1			
	G	M21 EG7 620							1	1	
4	G	M21 EAF 040	HORIZONTAL VANE		1	1	1	1	1	1	
5	G	M21 L9V 049	VANE SHAFT		1	1	1	1	1	1	
6	G	M21 EA4 279	STABILIZER ASSEMBLY		1	1	1	1	1	1	Including vertical vane
7	G	M21 L9V 915	LINK		1	1	1	1	1	1	CRANK SET
8	G	M21 L9V 306	VERTICAL VANE MOTOR	MV2	1	1	1	1	1	1	
9	G	M21 EA0 953	VANE MOTOR SUPPORT		1	1	1	1	1	1	
10	G	M21 EAL 306	HORIZONTAL VANE MOTOR	MV1	1	1	1	1	1	1	
11	G	M21 L9V 024	MOTOR BAND		1	1	1	1	1	1	
12	G	T2W ED4 300	INDOOR FAN MOTOR	MF	1	1	1	1	1	1	RC0J30-□□
13	G	M21 L9V 302	LINE FLOW FAN		1	1	1	1	1	1	
14	G	M21 L9V 504	SLEEVE BEARING		1	1	1	1	1	1	
15	G	M21 L9V 509	BEARING MOUNT		1	1	1	1	1	1	
16	G	T2W EA1 303	DRAIN PUMP SET	DP	1	1	1	1	1	1	Including CUSHION x 2, BASE, COVER SET
17	G	M21 L9V 312	FLOAT SENSOR	FS	1	1	1	1	1	1	
18	G	M21 EAG 307	ROOM TEMPERATURE THERMISTOR	RT11	1	1	1	1	1	1	
19	G	M21 L9V 783	SENSOR HOLDER		1	1	1	1	1	1	COVER, HOLDER SET
20	G	M21 EA2 703	DRAIN PIPE		1	1	1	1	1	1	
21	G	M21 L9V 249	DRAIN COVER		1	1	1	1	1	1	
22	G	M21 L9V 708	PIPE FIXING BAND		1	1	1	1			
	G	M21 L3W 708	PIPE FIXING BAND						1	1	
23	G	—	CABINET ASSEMBLY		1	1	1	1	1	1	DT00A664G77 Not including SPECIFICATION LABEL
24	G	M21 EA9 703	DRAIN HOSE		1	1	1	1	1	1	

# RoHS PARTS LIST

MLZ-KP25VF MLZ-KP35VF MLZ-KP50VF

## 1-2. INDOOR UNIT ELECTRICAL PARTS AND FUNCTIONAL PARTS

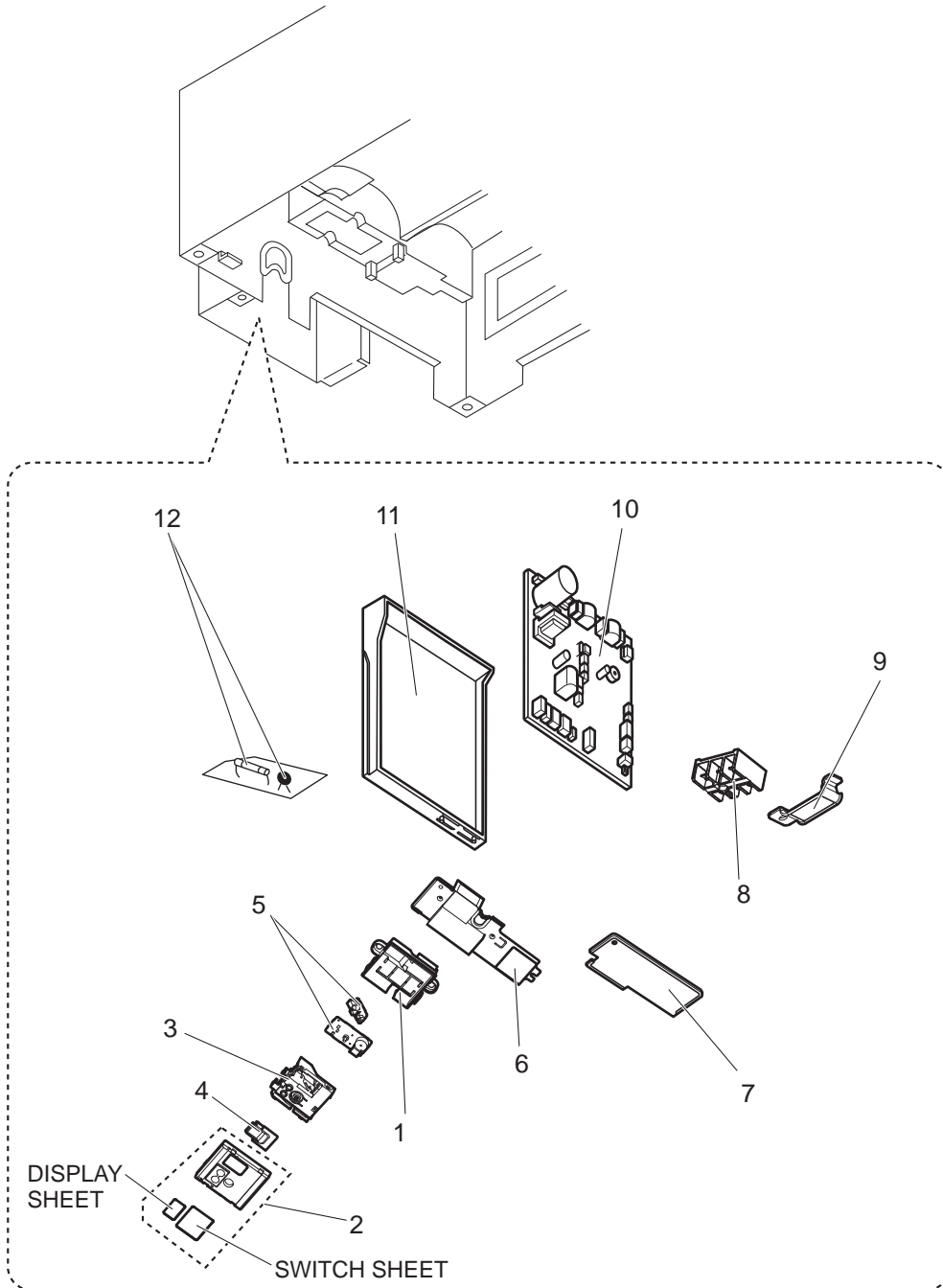

## 1-3. ACCESSORY AND REMOTE CONTROLLER

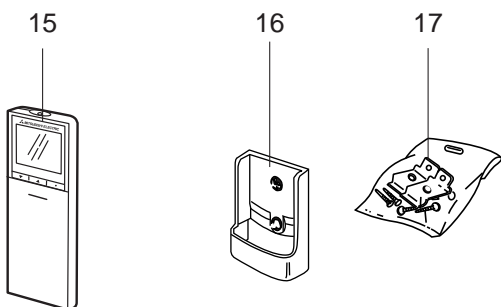

# RoHS PARTS LIST

## 1-2. INDOOR UNIT ELECTRICAL PARTS AND FUNCTIONAL PARTS

Part numbers that are circled are not shown in the illustration.

No.	RoHS	Part No.	Part Name	Symbol in Wiring Diagram	Q'ty/unit						Remarks
					MLZ-KP						
					25VF -		35VF -		50VF -		
E1	ER1	E1	ER1	E1	ER1						
1	G	—	DL COVER ASSEMBLY		1	1	1	1	1	1	RK00C864G02
2	G	—	DISPLAY RECEIVER COVER ASSEMBLY		1						RK00G135G18
	G	—	DISPLAY RECEIVER COVER ASSEMBLY			1					RK00G135G21
	G	—	DISPLAY RECEIVER COVER ASSEMBLY				1				RK00G135G19
	G	—	DISPLAY RECEIVER COVER ASSEMBLY					1			RK00G135G22
	G	—	DISPLAY RECEIVER COVER ASSEMBLY						1		RK00G135G20
	G	—	DISPLAY RECEIVER COVER ASSEMBLY							1	RK00G135G23
3	G	—	DISPLAY RECEIVER HOLDER		1	1	1	1	1	1	BK25V915G02
4	G	—	RECEIVER COVER		1	1	1	1	1	1	BK25V917G02
5	G	T2W EA6 326	DISPLAY RECEIVER P.C. BOARD ASSEMBLY		1	1	1	1	1	1	
6	G	—	PB COVER ASSEMBLY		1		1		1		RK00C861G03
	G	—	PB COVER ASSEMBLY			1		1		1	RK00C861G04
7	G	—	TB COVER ASSEMBLY		1		1				JG00G689G35
	G	—	TB COVER ASSEMBLY						1		JG00G689G36
	G	—	TB COVER ASSEMBLY			1		1			JG00G689G37
	G	—	TB COVER ASSEMBLY							1	JG00G689G38
8	G	M21 EA3 376	TERMINAL BLOCK	TB	1	1	1	1	1	1	3P
9	G	M21 N2A 784	VA CLAMP		1	1	1	1	1	1	
10	G	T2W F2A 450	ELECTRONIC CONTROL P.C. BOARD		1	1					
	G	T2W F2C 450					1	1			
	G	T2W F2D 450							1	1	
11	G	M21 L9V 784	ELECTRONIC CONTROL P.C. BOARD BOX		1	1	1	1	1	1	
12	G	M21 EA5 313	FUSE VARISTOR SET	F11, NR11, NR12	1	1	1	1	1	1	T3.15AL250V
⑬	G	—	LEAD WIRE ASSEMBLY (DISPLAY RECEIVER P.C. BOARD)		1	1	1	1	1	1	BT78G837G01
⑭	G	—	LEAD WIRE ASSEMBLY (VANE MOTOR)		1	1	1	1	1	1	DY00C301G02

## 1-3. ACCESSORY AND REMOTE CONTROLLER

No.	RoHS	Part No.	Part Name	Symbol in Wiring Diagram	Q'ty/unit						Remarks
					MLZ-KP						
					25VF -		35VF -		50VF -		
E1	ER1	E1	ER1	E1	ER1						
15	G	T2W EEY 426	REMOTE CONTROLLER		1	1	1	1	1	1	SG175
16	G	T2W EA0 083	REMOTE CONTROLLER HOLDER		1	1	1	1	1	1	
17	G	M21 EA6 250	SCREW ASSEMBLY		1	1	1	1	1	1	

# 2

# OPTIONAL PARTS

MLZ-KP25VF MLZ-KP35VF MLZ-KP50VF

2-1. GRILLE

MLP-444W: MLZ-KP-VF-E1, ER1

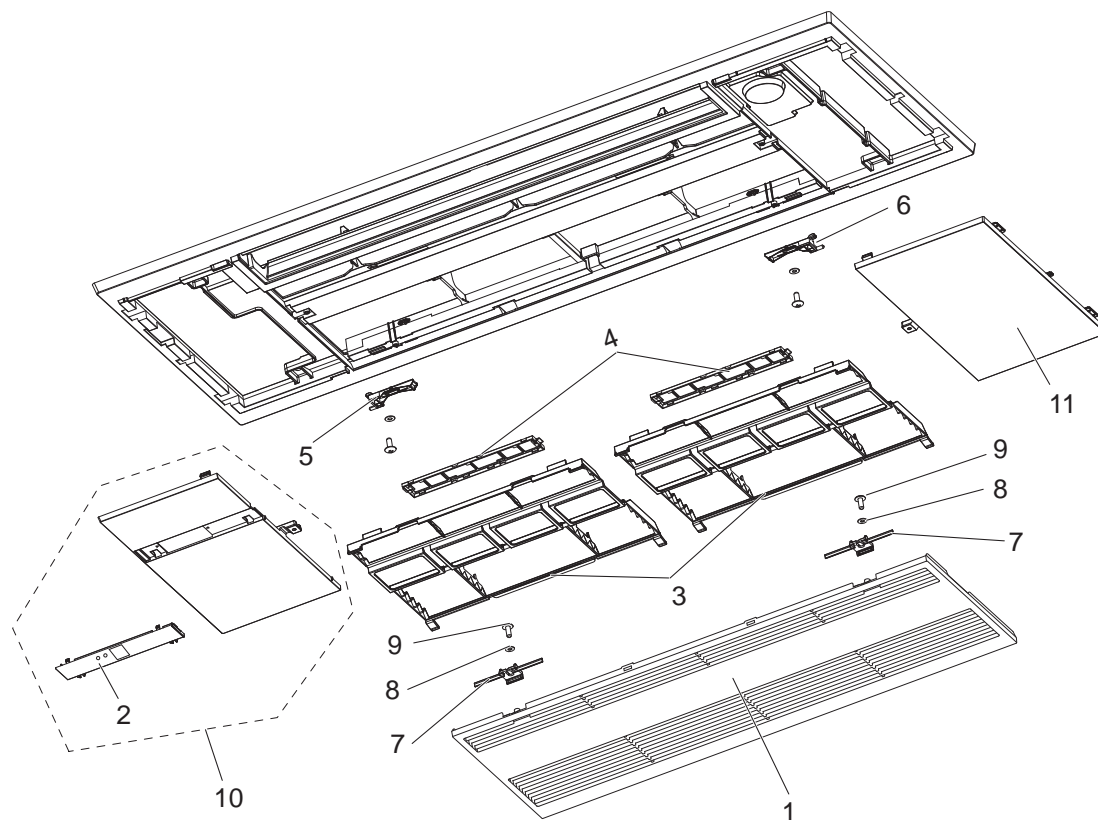

Part numbers that are circled are not shown in the illustration.

No.	RoHS	Part No.	Part Name	Symbol in Wiring Diagram	Q'ty/unit						Remarks
					MLZ-KP						
					25VF -		35VF -		50VF -		
<span style="border: 1px solid black; padding: 0 2px;">E1</span>	<span style="border: 1px solid black; padding: 0 2px;">ER1</span>	<span style="border: 1px solid black; padding: 0 2px;">E1</span>	<span style="border: 1px solid black; padding: 0 2px;">ER1</span>	<span style="border: 1px solid black; padding: 0 2px;">E1</span>	<span style="border: 1px solid black; padding: 0 2px;">ER1</span>						
1	G	M21 ECA 010	GRILLE ASSEMBLY (W)		1	1	1	1	1	1	
2	G	T2W EB0 093	DISPLAY COVER SET		1	1	1	1	1	1	
3	G	M21 EBF 100	AIR FILTER (AIR PURIFYING FILTER)		2	2	2	2	2	2	
4	G	—	AIR CLEANING FILTER (SILVER-IONIZED AIR PURIFIER FILTER)		1	1	1	1	1	1	MAC-2370FT-E
5	G	M21 EA0 054	GRILLE SHAFT L		1	1	1	1	1	1	
6	G	M21 EA1 054	GRILLE SHAFT R		1	1	1	1	1	1	
7	G	M21 EAC 049	GRILLE KNOB (W)		2	2	2	2	2	2	
8	G	—	WASHER		2	2	2	2	2	2	Z006Z051H07
9	G	—	SCREW		2	2	2	2	2	2	Z004Z015H37
10	G	T2W EA6 975	SIDE PANEL L ASSEMBLY (W)		1	1	1	1	1	1	
11	G	M21 EAZ 976	SIDE PANEL R ASSEMBLY (W)		1	1	1	1	1	1	
<span style="border: 1px solid black; border-radius: 50%; padding: 2px;">12</span>	G	M21 EAF 067	SCREW CAP (W)		1	1	1	1	1	1	
<span style="border: 1px solid black; border-radius: 50%; padding: 2px;">13</span>	G	M21 EA9 250	SCREW ASSEMBLY		1	1	1	1	1	1	

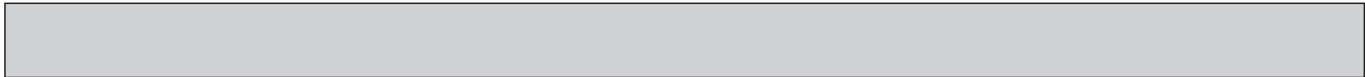

## GRILLE: MLP-444W

### 1.SPECIFICATION

ITEM		CONTENTS
EXTERIOR	COLOR(MUNSELL NO.)	WHITE(4.0GY 9.1/0.2)
	SURFACE TREATMENT	NONE
	MATERIAL	ABS RESIN
MASS		3.5kg

### 2.OUTLINE DRAWING

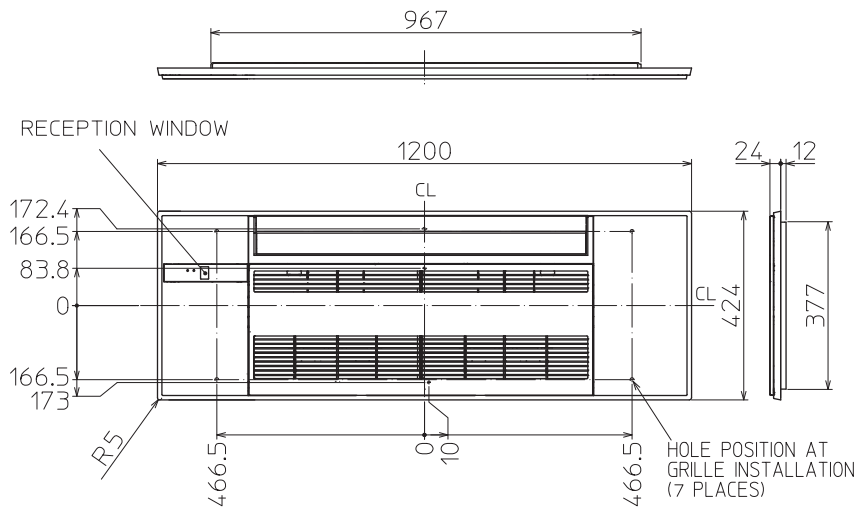

## 2-2. AIR FILTER (AIR PURIFYING FILTER)

- Clean every 2 weeks
- Remove dirt by a vacuum cleaner, or rinse with water.
- Dry it well in shade before installing it.
- Install the tabs into the intake grille hole.

### NOTE:

- Clean the filters regularly for best performance and to reduce power consumption.
- Dirty filters cause condensation in the air conditioner which will contribute to the growth of fungi such as mold.

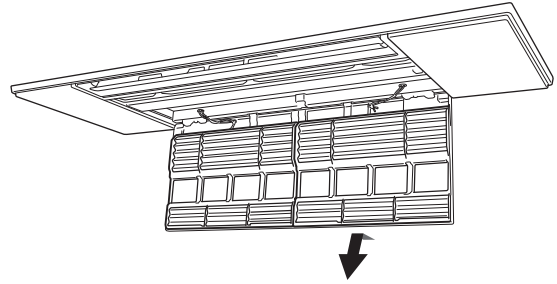

## 2-3. AIR CLEANING FILTER (SILVER-IONIZED AIR PURIFIER FILTER)

Back side of air filter  
Clean every 3 months:

- Remove dirt by a vacuum cleaner.
- Install the tabs into the intake grille hole.

### When dirt cannot be removed by vacuum cleaning:

- Soak the filter and its frame in lukewarm water before rinsing it.  
(Diluted mild detergents can be used when dirt cannot be removed.)
- After washing, dry it well in shade.

### Every year:

- Replace it with a new air cleaning filter for best performance.

### NOTE:

- Clean the filters regularly for best performance and to reduce power consumption.
- Dirty filters cause condensation in the air conditioner which will contribute to the growth of fungi such as mold.

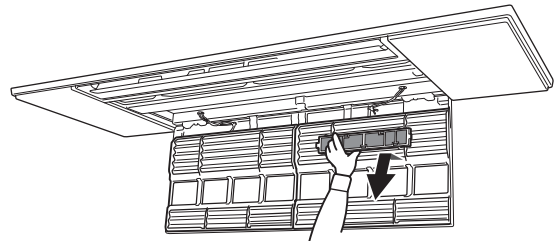

Model	Part No.
MLZ-KP25VF- E1, ER1	MAC-2370FT-E
MLZ-KP35VF- E1, ER1	
MLZ-KP50VF- E1, ER1	

# MITSUBISHI ELECTRIC CORPORATION

HEAD OFFICE: TOKYO BUILDING, 2-7-3, MARUNOUCHI, CHIYODA-KU, TOKYO 100-8310, JAPAN

© Copyright 2018 MITSUBISHI ELECTRIC CORPORATION  
Published in Feb. 2018 No. OBB801  
Made in Japan

Specifications are subject to change without notice.