

Mitsubishi Electric Air-conditioner Network System

Central Controller Model: G-50A

Installation Manual

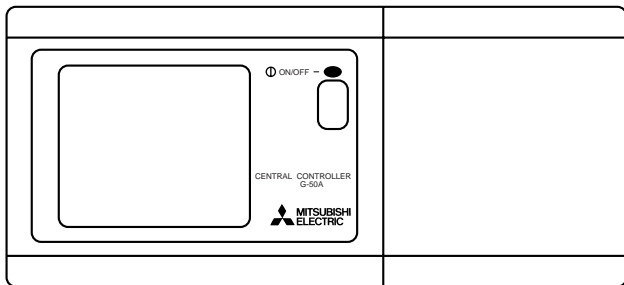

Contents



1. Safety precautions to be observed without fail	1
2. Confirmation of parts	2
3. Outline dimensions	2
4. System diagram	3
5. Installation method	4
1. Part prepared at site	4
2. Installation method	4
6. Initial setting	5
1. Address setting method	5
2. Function selection method	5
3. IP address setting method	6
4. Group setting	6
5. Others	6
7. Test run	7
8. Example for system configuration	7
1. To control a K control model	7
9. External input/output usage method	7
1. External signal input function	7
2. External signal output function	8
3. LAN connection function	9
4. RS232C connection function	9

Before using the controller, please read this Installation Manual carefully to ensure correct operation. Store this Installation Manual in a location that is easy to find.

This manual describes the installation of the central controller and wiring to the air conditioner. Refer to the installation manual of the air conditioner. Carefully read item (1) Safety precautions to be observed without fail before installing the unit.

1 Safety precautions to be observed without fail

* Hazards and levels of danger that can occur due to incorrect handling are classified by the following symbols.

 Warning	Incorrect handling can result in death, serious injury, etc.
 Cautions	Incorrect handling can result in injury or damage to the building or its contents.

* After reading this manual, keep in a handy place. When removing or repairing the unit, give this manual to the installer. When the user changes, also give to the new user.

 Warning	
<p>Ask your dealer or technical representative to install. If incorrect installation is done by a customer, it may cause an electric shock, fire, etc.</p>	<p>Securely install the controller according to the installation manual. If installation is not correct, it may cause an electric shock, fire, etc.</p>
<p>Securely install in a place which can withstand the weight of the controller. If it is not enough, the unit may fall and cause an injury.</p>	<p>The electric work should be performed by authorized personnel according to the installation manual. Any lack of electric circuit or any deficiency caused by installation may result in an electric shock or fire.</p>
<p>Securely connect the wiring using the specified cables and fix them so that the stress from the cables is not applied to the terminal connection sections. If connection or fixing is not sure, it may cause heat generation, a fire, etc.</p>	<p>Do not move and re-install the unit by yourself. If installation is not correct, it may cause an electric shock, fire, etc. Ask your dealer or technical representative.</p>
<p>Never modify or repair by yourself. If the controller is modified or a repair is not correct, it may cause an electric shock, fire, etc. Consult your dealer if repairs are necessary.</p>	

 Cautions	
<p>Do not install the controller in a place where flammable gas could leak. If gas leaks and collects around the unit, it may cause a fire or explosion.</p>	<p>Do not install this controller in a place where steam is generated such as bathroom, kitchen, etc. Avoid placing where water condenses on the walls. It may cause an electric shock or malfunction.</p>
<p>Do not use this controller in an abnormal environment. If the controller is used in a place where there is much oil (including machine oil), steam or sulfide gas, the performance of the controller may deteriorate or parts may be damaged.</p>	<p>Do not install this controller in a place where an acid or alkaline solution, special spray, etc. is used frequently. It may cause an electric shock or malfunction.</p>
<p>Perform wiring so the tension is not applied. If tension is applied, it may cause disconnection, heat generation or a fire.</p>	<p>Use specified wires corresponding to the current capacity for wiring. Otherwise it may cause power leakage, heat generation or fire.</p>
<p>Seal the wire lead-in port with putty to prevent the entry of dew, water, insects, etc. It may cause an electric or malfunction.</p>	<p>Do not touch the PCB (Printed Circuit Board) with your hand or a tool. Also do not get dirt on the PCB. It may cause a fire or malfunction.</p>
<p>Do not wash this controller with water. It may cause an electric shock or malfunction.</p>	<p>Do not touch the switches with wet hands. It may cause an electric shock or malfunction.</p>
<p>Do not install this controller in a place where the ambient temperature exceeds 40°C (104°F) or drops below 0°C (32°F), also do not install in a place where it is exposed to direct sunlight. It may cause a deformation or malfunction.</p>	<p>Do not press the switches with sharp objects. It may cause an electric shock or malfunction.</p>
	<p>Do not connect an AC power source to the M-NET and Power (DC12V) terminal blocks of this device. It may cause a breakdown or fire.</p>

2 Confirmation of parts

* Please confirm that in addition to this Installation Manual the following items are enclosed in the box.

No.	Part name	Qty.
①	Central controller	1
②	Installation plate	1
③	Wood screw 4.1×16 (use when directly installing on the wall)	2
④	M4 round head screw for main unit installation	2
⑤	M3 round head screw for cover fixing	1
⑥	M4 countersunk screw (M4×40) for installation plate fixing	3
⑦	Instruction book	1

* If the screw enclosed for installation plate fixing cannot be used because the wall is thick, prepare an M4 countersunk screw with a length matching the wall thickness.

* Besides the above parts, purchase a power supply unit (PAC-SC50KUA) that supplies power (DC12V) to the central controller and to the M-NET transmission line.

3 Outline dimensions

Unit: mm (in)

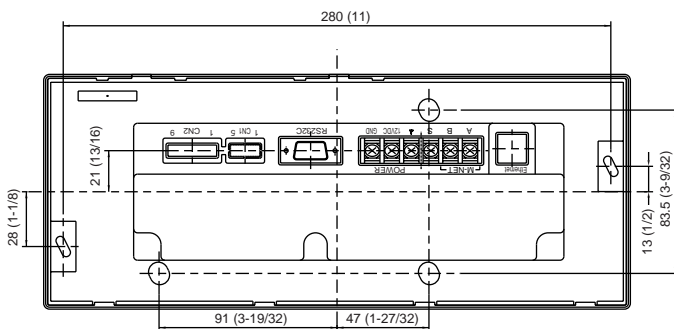
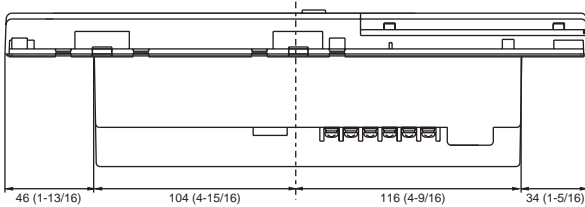
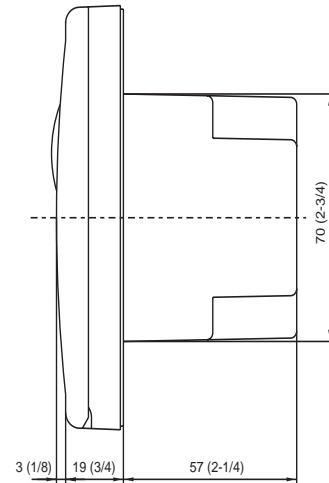
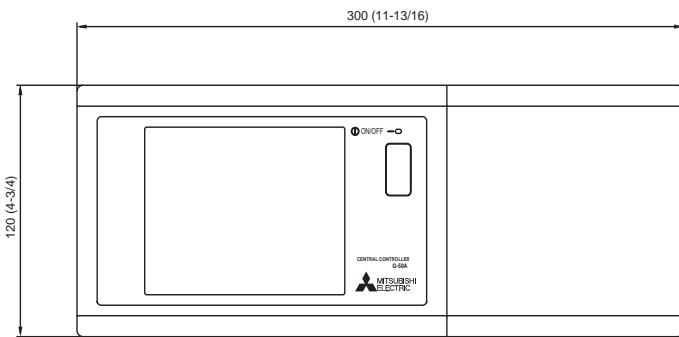

Installation plate

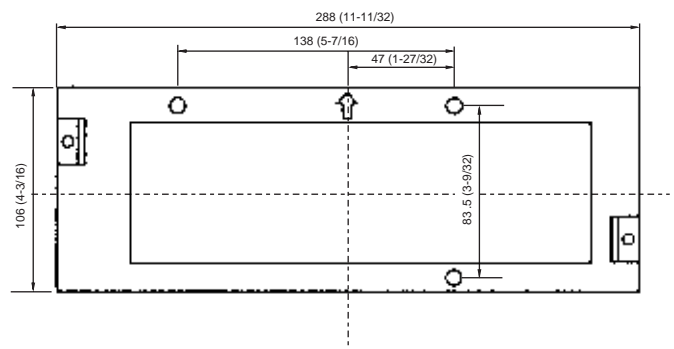

4 System diagram

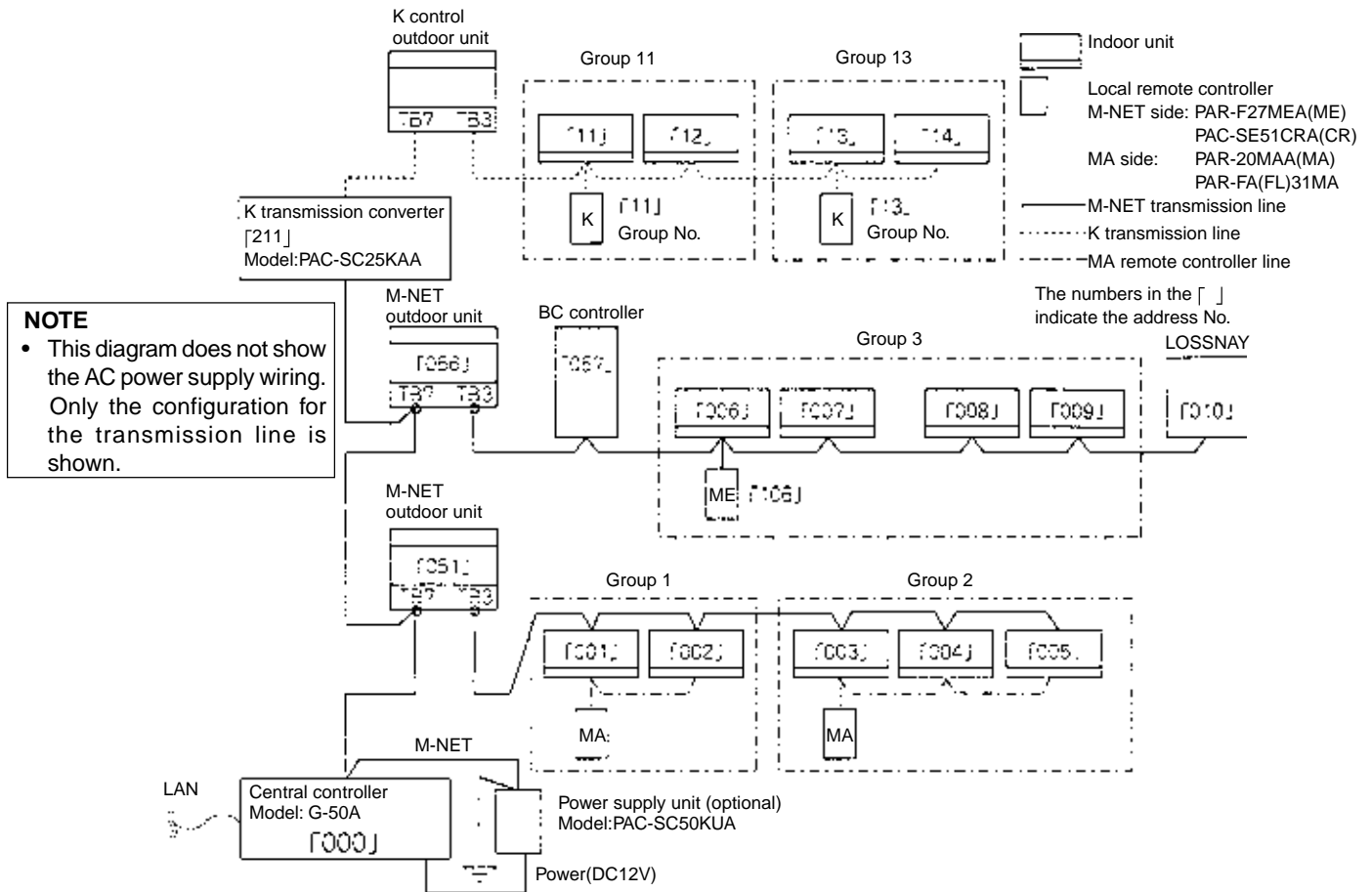

* Address setting for each M-NET device (The same address cannot be duplicated.)

* The K transmission converter (PAC-SC25KAA) and OA processing unit (LOSSNAY) are not included in systems shipped to North America (USA & Canada).

	Address setting method	Address
Indoor unit	Set the indoor unit you want to make the master unit in the same group to the minimum address, and sequentially set the indoor unit addresses in the same group.	1~50
Outdoor unit	Min.indoor unit address in same refrigerant system + No.50 unit.	51~100
BC controller/OS controller	Outdoor unit address in same refrigerant system + No.1 unit. However, for Sub-BC controller, minimum indoor unit address that connects the local refrigerant piping + 50.	52~100
K control side remote controller	Same address as indoor unit master unit	1~50
M-NET remote controller	Set to the minimum indoor unit master address in the same group + 100.	101~200
MA remote controller	Address setting is unnecessary.	-
OA processing unit/LOSSNAY	After setting all the indoor units, set an arbitrary address.	1~50
K transmission converter	Min.address of K control indoor unit + No.200 unit.	201~250

NOTE

* The following precautions will apply when using the K transmission converter (model:PAC-SC25KAA) and controlling the M-NET model and K control model with the same controller.

Refer to the K transmission converter installation manual for details.

- ① Central controller address
Always set the controller address to "000".
(Refer to section (6) Initial setting.)
- ② Central controller function selects
Always set the No.3 function selects of the controller to "ON"
(Refer to section (6) Initial setting.)
- ③ Indoor unit address
Set all M-NET model indoor units from the No.1 unit, and then set the K control model addresses.
Indoor unit No.1 unit ~M-NET indoor unit max. address->K control indoor unit min. address ~50
- ④ K control model group No.
The min.indoor address No. of that group becomes the group No. (Same for K control side local remote controller.)

5 Installation method

Unit: mm (in)

1. Parts prepared at site

- ① Prepare an electric box.
- ② Prepare lock nuts and bushing that match the conduit.
- ③ Prepare an M-NET transmission line CVVS(2-wire): 1.25mm² (AWG 16) or equivalent.
- ④ DC power supply line (3-conductor): Provide 0.75mm² (AWG 18) or greater.

2. Installation method

- ① Secure the space shown on the right when installing the electric box.
- ② When installing the controller on the electric box, the controller will be shifted by 1mm (1/32 in) to the left as shown above.

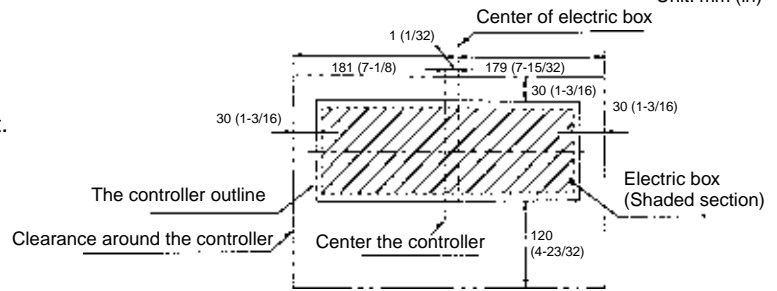

NOTE

- * When installing two controllers horizontally in parallel, secure a clearance of 30mm (1-3/16 in) or more between the products. When installing vertically with the same clearance, removing of the cover will be difficult.
 - * When connecting a LAN and RS-232C, a space for the connector and wiring is required. Provide this space between this unit and the rear of the electric box.
- It varies depending on the specifications of the LAN cable and RS-232C cable that is procured, but the LAN connector may protrude approximately 20mm (25/32 in) and the RS-232C connector may protrude approximately 40mm (1-9/16 in) from the bottom of the unit cabinet. Provide a cable with the smallest possible connector to secure space.
- Reference example) Example of installation when a 67mm (2-5/8 in) deep electric box is used with a 30mm (1-3/16 in) thick wall.

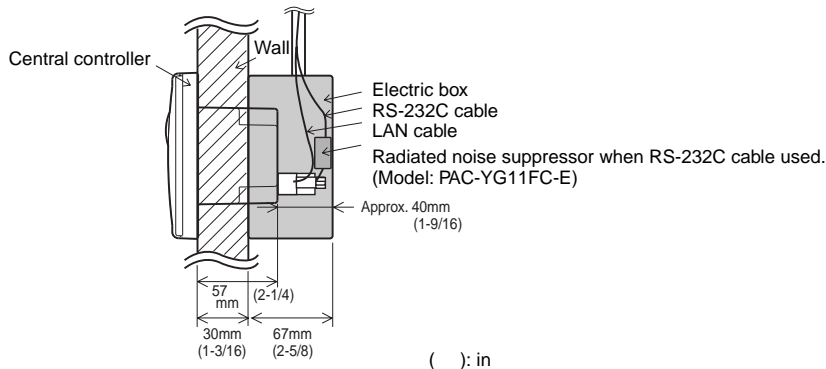

- ③ Connect the M-NET transmission line (centralized control line which is connected to TB7 of the outdoor unit) to M-NET transmission line terminal A and B. (Non Polarity)
- Connect the DC power line from the power supply unit (PAC-SC50KUA) to the DC power supply terminal block of this device. There is a 12VDC and a GND polarity.

- * Type of wire. Use the cables which comply with the following specifications or equivalent.

M-NET transmission line:

CVVS 1.25mm²/AWG 16 (PVC-insulated, PVCsheathed shield control cable)

CPEVS ø1.2mm/AWG 17 (PE-insulated, PVC-sheathed shield communication cable)

DC power line: 0.75mm²/AWG 18 or greater 3-conductor power line

CAUTION

- * Do not connect the AC power line to the M-NET and POWER (DC12V) terminal blocks of this device. It may cause a failure.
- * Do not connect to the M-NET transmission line of indoor unit control line which is connected to TB3 of the outdoor unit.
- * The conduit outlet faces only vertically. When leading the line out from above, seal the port so that water does not enter along the transmission line and DC power supply line.

- ④ Securely seal the line lead-in port with putty to prevent the entry of dew, water and insects, etc.

- * Seal the connecting section of the electric box and conduit with putty.

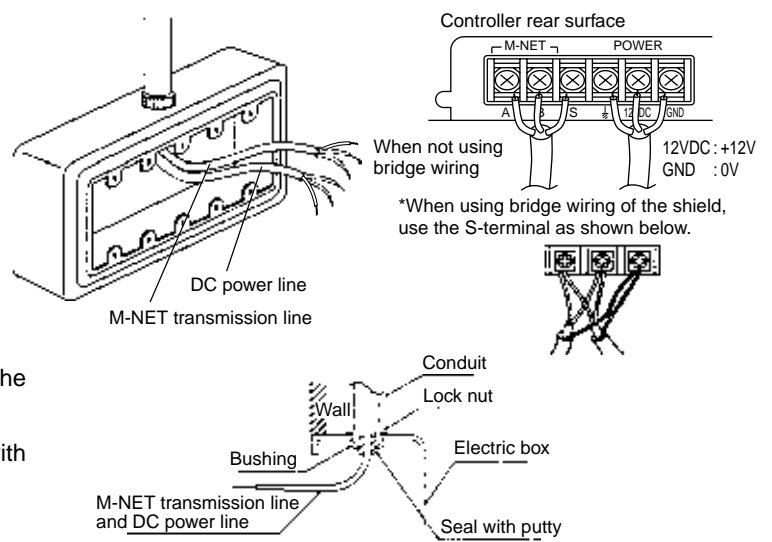

- ⑤ Remove the controller's cover and install on to the electric box.

(NOTE)
The cover fixing screw is packaged with the other enclosed screws.
Insert a flat-tip screwdriver and rotate it to remove the cover.

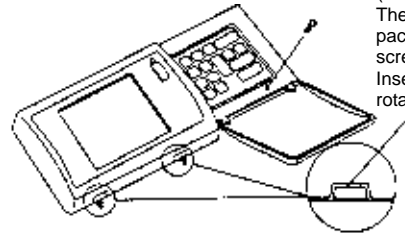

<Installation on to electric box>

NOTE

- * When installing the controller directly on to a wall instead of using the electric box, do not use the installation plate.
- * If the screw enclosed for the installation plate, fixing cannot be used because of the wall thickness, prepare an M4 countersunk screw that matches the wall thickness.
- * When using an LAN and external signal I/O, refer to section 9 External input/output usage method.

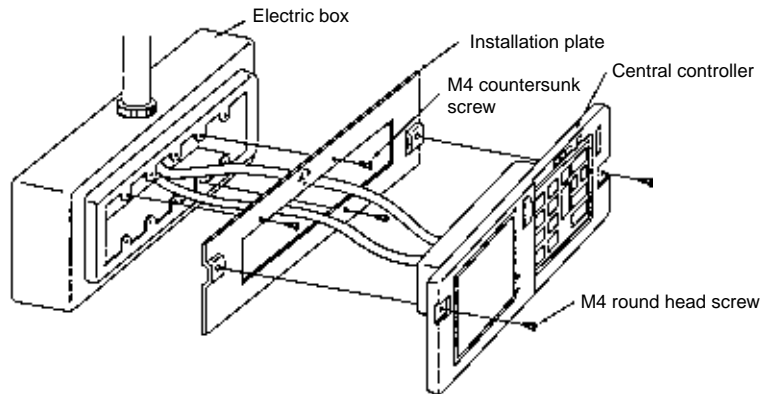

6 Initial setting

* Turn on the power supply unit (PAC-SC50KUA) power and run and initially set this unit. When the power is first turned on, the startup screen shown at the right is displayed.

(When changing the initially set contents after various initial settings were performed and the system was already started, the initial setting menu screen is displayed by pressing the \uparrow and \downarrow switches simultaneously for 2 seconds or longer during user operation menu screen display.)

At the end of various initial settings, return to the user operation menu screen by pressing the \uparrow and \downarrow switches simultaneously for 2 seconds or longer.

Refer to the attached instruction book section 5. Initial setting for further information.

- 1 ADDRESS SETTING
- 2 FUNCTION SETTING
- 3 IPADDRESS SETTING
- 4 GROUP SETTING

PLEASE SET INITIAL SETTING

1. Address setting method

- ① When the startup screen is displayed at power on, press the $\boxed{1}$ switch to select "1 ADDRESS SETTING".
- ② Press the $\boxed{0}$ ~ $\boxed{9}$ switches, and set the address of this unit. (000,201~250)
- ③ When the $\boxed{\text{BACK SCREEN}}$ switch is pressed after setting, the screen returns.

* Always set to [000] when using K transmission converter.
* The M-NET address initial value of this unit is [000].

2. Function selection method

- ① On the startup screen, press the $\boxed{2}$ switch to select "2 FUNCTION SETTING".
- ② Switch the function by pressing the $\boxed{1}$ ~ $\boxed{8}$ switch of the same No. as the function No. you want to change.
Each time the switch is pressed, the ON/OFF state of that No. is changed.
No.1 and No.2 cannot be changed.
When Function No. 3 is set to ON, set the K transmission converter address.
Move the address and Function setting using the \uparrow , \downarrow , \rightarrow , and \leftarrow keys.

<Operation example>

- 1) When the $\boxed{3}$ switch was pressed



- ③ When the $\boxed{\text{BACK SCREEN}}$ switch is pressed, the screen is returned.

<Function Selection Display>

- No. 1 — OFF : Not used (Fixed to off)
- No. 2 — OFF : Not used (Fixed to off)
- No. 3 — OFF : K transmission converter not provided/ON:K trahsmission converter provided
- No. 4 — OFF : Operation prohibit transmission valid/ON:Operation prohibit transmission invalid
- No. 5 — OFF : Emergency stop broadcast enabled/ON: Emergency stop broadcast disabled
- No. 6 — External input changeover
- No. 7 —
- No. 8 — The range of a controller which the operation is prohibited.
OFF : Both of the systems controller and the local remote controller/ON:Only the local remote controller

<Meanings of function selects>

Function	State	Name	Details
No.1	Fixed to OFF		Not used. Always set this to "OFF"
No.2	Fixed to OFF		Not used. Always set this to "OFF"
No.3 *1	OFF	K transmission converter not provided	The packaged air conditioner to be used is only an M-NET model.
	ON	K transmission converter provided	K control model is included in the packaged air conditioner being used.(In this case, set the controller address "000".) Set the K transmission converter address at this screen. Prepare the K transmission converter (PAC-SC25KAA) separately.
No.4	OFF	Operation prohibit valid	Set this when using as a system controller for which local remote operation prohibit can be set. A system controller set to this can be used only for external input. Note that only one unit can be used in the system.
	ON	Operation prohibit invalid	Set this when using as a system controller for which local remote operation prohibit cannot be used. Set only one unit in the system to the operation prohibit transmission valid setting, and set all other units to the invalid setting.
No.5	OFF	Emergency stop broadcast enabled.	Please be sure to make it "OFF" setting.
	ON	Emergency stop broadcast disabled.	
No.6,7	OFF/ON	External input changeover	This changes the input when using CN3 (external input I/F). (Refer to section (9) External input/output usage method) for details.)
No.8	OFF	The range of a controller which the operation is prohibited.	Both of the system controller and the local remote controller.
	ON		Only the local remote controller.

*1 The K transmission converter (PAC-SC25KAA) is not included in systems shipped to North America (USA & Canada) Always set this to "OFF".

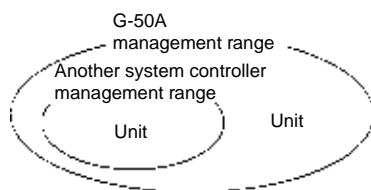

When G-50A controls another system controller or when the system contains only G-50A: G-50A is set as the master system controller,

* G-50A performs the group setting in this configuration.

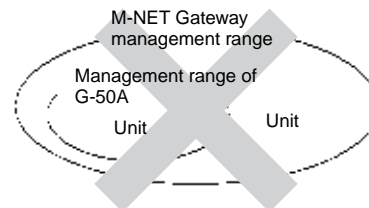

* G-50A does not support slaves.

When G-50A is controlled by another system controller: G-50A is set as the slave system controller.

* The group setting is performed by Master system controller.

3. IP address setting method

When connecting an LAN to this unit, set the IP ADDRESS and MASK ADDRESS.

- ① On the startup screen, press the switch to select "3 IP ADDRESS SETTING".
- ② When the () or () switch is pressed, the cursor moves to right or left.
- ③ Set both addresses using the ~ switches.
- ④ When the switch is pressed, the screen is returned.

4. Group setting

* Set the group configuration with indoor units, local remote controllers (only when M-NET type used) and slave system controller to be controlled by this unit.

* Select "4 (or 1) Group Setting" on the menu screen in the initial setting mode, and set the group configuration.

* Refer to the attached instruction book section 5 Initial Setting for the initial setting method.

5. Others

* Since the screen switches from the startup screen to the initial setting menu screen after group setting, choose the menu and perform setting and monitoring, as required.

- Interlocked setting (Sets interlocking between ventilator and indoor unit.)
- refrigerant monitor (Outdoor unit and indoor unit refrigeration connection can be monitored.)
- malfunction monitor (Past abnormality history can be monitored.)
- user setting (Real-time display information selection and setting)

Refer to the attached instruction book sections 5-5 Interlocked operation setting to 6-2 Malfunction log monitor function for a detailed description of the functions and settings.

When all the initial settings are complete, initiate startup communication by holding down the and switches on the initial setting menu screen simultaneously for at least 2 seconds. After a while, the display shifts to the user operation menu screen.

Refer to the attached instruction book section 5.Initial setting for further information.

7 Test run

- * After setting the group or interlocked setting, confirm that the controller has started up, and then perform a test run.
 - * It may take approx. 10 minutes for local remote controller operation to be enabled after the power is turned ON. In this case, press the ON/OFF button on the controller to enable immediate local remote controller operation.
- (Test run procedure)

1. Turn ON the Power to the controller and all the units.
 2. When the "INITIAL SETTING (PLEASE WAIT)" blink on the controller LCD stops, press the "① ON/OFF switch" and the "temperature setting switch ▲" at the same time.
 3. Confirm the run state (indoor unit outlet air temperature, cool air, confirmation, etc.) during the test run.
 4. When each unit has been confirmed, stop the unit with the controller or local remote controller. Even if the units are not stopped, the test run will stop automatically after approx. 2 hours.
- * Refer to the installation manual for the connected indoor unit for details on the test run method.

8 Example for system configuration

1. To control a K control model

- * Set G-50A address to "000" When a K transmission converter is connected. Always set to the master system controller when the address is "000".
- * When using a group setting for the K control model, set only the indoor unit that belongs to that group.
- * Set the min.indoor unit address in the group for the K control model group No.
- * Set the master system controller function select No.4 to "OFF" (operation prohibit transmission valid) when the K transmission controller is connected.

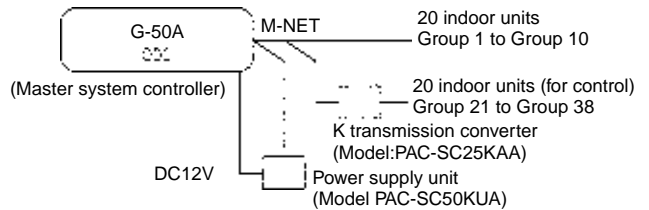

9 External input/output usage method

1. External signal input function

- * External signal input requires the external I/O adapter (Model: PAC-YG10HA-E) sold separately.

(1) External input

Emergency stop/normal, run/stop and prohibit/enable of local remote controller operation can be controlled for all air conditioners being controlled by using a voltage (DC12V or DC24V) contact signal from an external source. (Select with the function select setting)

No.	External signal input function	Function		Remarks
		No.6	No.7	
1	Do not use external input signal (factory setting)	OFF	OFF	
2	Execute emergency stop/normal with level signal	OFF	ON	The local remote controller ON/OFF operations, and the controller ON/OFF operation and prohibit/enable change operations will be prohibited during emergency stop.
3	Perform ON/OFF with level signal	ON	OFF	The local remote controller ON/OFF operations, and the controller ON/OFF operations and prohibit/enable change operations will be prohibited.
4	Perform ON/OFF, prohibit/enable with pulse signals.	ON	ON	Set the pulse width while the contact is ON to 0.5 to 1 sec.

(2) Level signal and pulse signal (DC12V or DC24V)

(A) Level signal

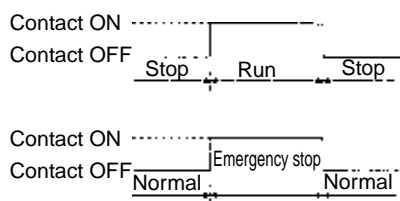

(B) Pulse signal (Example) for ON/OFF

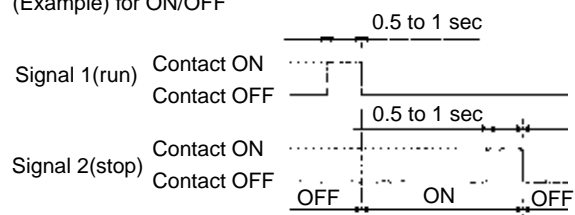

*The prohibit/enable input is the same.

(3) External input specifications

CN2	Lead wire	Emergency stop/normal level signal	ON/OFF, level signal	ON/OFF, prohibit/enable pulse signal
No.5	Orange	Emergency stop/normal input	ON/OFF input	ON input
No.6	Yellow	Not used	Not used	OFF input
No.7	Blue	Not used	Not used	Local remote controller operation prohibit input
No.8	Gray	Not used	Not used	Local remote controller operation enable input
No.9	Red	External DC source “+”		

(A) For level signal

- ① When the emergency stop/normal signal is selected, the status will change from normal to emergency stop when the external input signal contact changes from OFF to ON, and will change from emergency stop to normal when the contact changes from ON to OFF.
- ② When the ON/OFF signal is selected, the status will change from OFF to ON when the external input signal contact changes from OFF to ON, and will change from ON to OFF when the contact changes from ON to OFF.

(B) For pulse signal

- ① Even if the ON signal is input during ON, the status will remain ON.
- ② If the local remote controller is prohibited, the ON/OFF operation mode and temperature setting operations by the local remote controller will be prohibited.
- ③ Set the pulse width (contact ON time) to 0.5 to 1 sec.

(4) Recommended circuit example

(A) For level signal

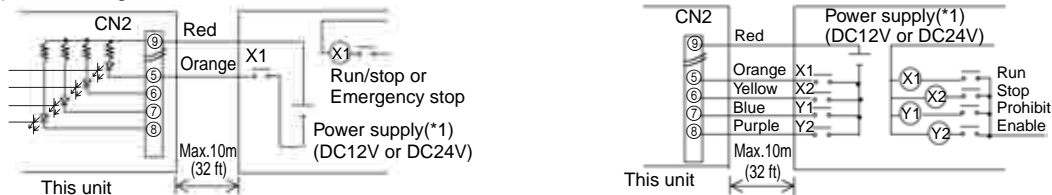

- ① The contact relay, DC power source, extension cable, etc., must be prepared separately at the site.
- ② The connection cable can be extended up to 10m (32 ft). (Use a 0.3mm² (AWG 22) or larger wire.)
- ③ Strip the extra cable near the connector, and securely insulate the exposed section with tape, etc.

2. External signal output function

* External signal output requires the external I/o adapter (Model: PAC-YG10HA-E) sold separately.

(1) External output

When one or more air conditioners are running, the “ON” signal will be output and if a malfunction occurs in one or more air conditioners, the “Malfunction” signal will be shown.

(2) External output specifications

CN 2	Lead wire	Details of each terminal
No.1	Green	Common (External ground)
No.2	Black	ON/OFF
No.3	Brown	Malfunction/normal
No.9	Red	Common (External power supply) (*1)

- ① “ON” signal and “Malfunction” signal will both be shown.

(3) Recommended circuit example

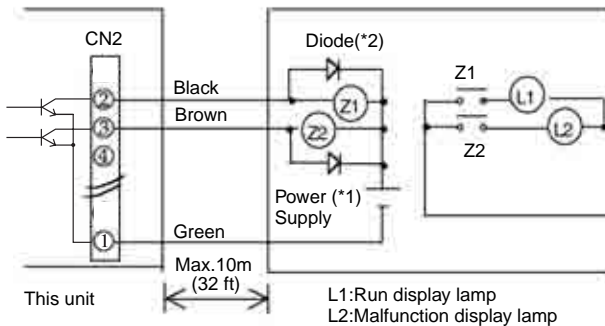

Use Z1 and Z2 relays having the following specifications.
 Operation coil
 Rated voltage :DC12V,DC24V
 Power Consumption : 0.9W or less
 (*1) Prepare a power supply separately according to the relay being used. (DC12V or DC24V)
 (*2) Always insert a diode on both ends of the relay coil.

- ① Each element will turn on while ON operation or a malfunction occurs.
- ② The connection cable can be extended up to 10m (32 ft).
- ③ The relays, lamps, diodes and extension cables, etc, must be prepared separately at the site.

⚠ CAUTION

When connecting the external input/output cables to connector CN2 on the controller, Peel off the label on the controller connector section.

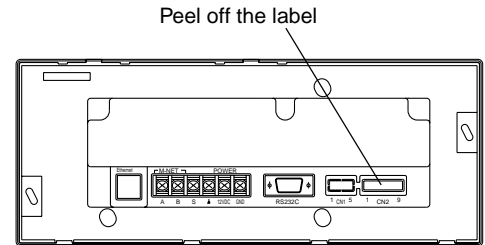

3. LAN connection function

When using the LAN connection function, connect the LAN cable to the Ethernet connector of this device.

- * Procure the LAN cable at the site, and use an enhanced category 5UTP cable.
- * For a description of the IP address setting method, refer to section (6 Initial setting).
- * LAN is 10 BASE-T Specification.

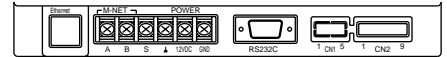

NOTE

- * Perform the LAN wiring before installation, and wire up to the body by the same method as wiring the M-NET transmission line.
- * When a LAN is already connected, decide the IP address by consultation with the system administrator and connect to the LAN body after changing the IP address.
- * When connecting an LAN connector, space for the connector and wiring is required. Provide this space at this unit and the rear of the electric box. Refer to section (5 Installation method).
- * When the G-50A cover is opened, the LAN status lamp and LAN changeover switch are accessed. For detailed information, refer to sections 3-2 and 5-9 of the Instruction Book.

4. RS232C connection function

When using an RS232C port, connect the cable to the RS232C connector of this device.

- * The RS232C cable is procured at the site, and the connector of the cable that connects to this device is a D-Sub9pin (female). RS-232C cable is maximum 15m (49 ft).
- * When using an RS-232C cable, to suppress the noise radiated from the RS-232C communication line, always procure the option Model PAC-YG11FC-E and install it so that the RS-232C communication line is inserted near the D-sub connector of the G-50A.

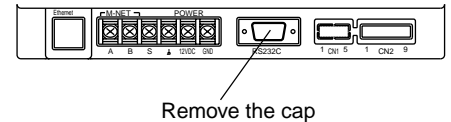

NOTE

- * When installing G-50A to the electric box, the D-sub connector does not pass through the conduit. In this case, use a type that can be separated from the D-sub connector cable. Remove the D-sub connector from the cable, pass the cable through the conduit, connect the cable to the D-sub connector using solder, etc., and then connect the D-sub connector to this unit.
- * When connecting the RS-232C connector, a connector and wiring space is required. Provide this space at this unit and the rear of the electric box. Refer to section (5 Installation method).
- * Wire the RS-232C before installation, and wire up to the body by the same method as wiring the M-NET transmission line.

This product is designed and intended for use in the residential,
commercial and light -industrial environment.

The product at hand is
based on the following
EU regulations:

- Low Voltage Directive 73/23/EEC
- Electromagnetic Compatibility Directive 89/
336/EEC