

Hot Water Heat Pump Unit

CAHV

Installation/Operation Manual

CAHV-P500YA-HPB

CONTENTS

| | |
|--|----|
| Safety Precautions..... | 2 |
| 1. Selecting the Installation Site..... | 8 |
| [1] Installation Conditions..... | 8 |
| [2] Installation Space Requirements | 9 |
| 2. Installation of Unit | 12 |
| 3. Water Pipe Installation..... | 13 |
| [1] Caution for Water Pipe Installation..... | 13 |
| [2] Installing the Water Pipes | 16 |
| [3] Water Pipe Hole Size and Location | 16 |
| 4. System Configurations..... | 17 |
| [1] System Configuration..... | 17 |
| [2] Configuring the System..... | 18 |
| [3] Settings the Operating Conditions (time and water temperature)..... | 20 |
| 5. Electrical Wiring Installation | 40 |
| [1] Wiring of Main Power Supply and Equipment Capacity | 40 |
| [2] Cable Connections..... | 42 |
| 6. Troubleshooting | 46 |
| [1] When No Errors Are Displayed..... | 46 |
| [2] Diagnosing Problems Using Error Codes | 47 |
| 7. Operating the Unit..... | 51 |
| [1] Initial Operation..... | 51 |
| [2] Daily Operation | 51 |
| [3] How to Operate..... | 52 |
| [4] Function Selection | 57 |
| [5] Using the Unit in Sub-freezing or Snowy Conditions..... | 59 |
| 8. Main Specifications..... | 60 |

Thoroughly read this manual prior to use.

Save this manual for future reference.

Some of the items in this manual may not apply to made-to-order units.

Make sure that this manual is passed on to the end users.

Safety Precautions

- Thoroughly read the following safety precautions prior to use.
- Observe these precautions carefully to ensure safety.



WARNING

Indicates a risk of death or serious injury



CAUTION

Indicates a risk of injury or structural damage



IMPORTANT

Indicates a risk of damage to the unit or other components in the system

All electric work must be performed by personnel certified by Mitsubishi Electric.

■ General



WARNING

Do not install the unit in a place where large amounts of oil, steam, organic solvents, or corrosive gases, such as sulfuric gas, are present or where acidic/alkaline solutions or sprays containing sulfur are used frequently.

These substances can compromise the performance of the unit or cause certain components of the unit to corrode, which can result in refrigerant leakage, water leakage, injury, electric shock, malfunctions, smoke, or fire.

Do not try to defeat the safety features of the unit or make unauthorized setting changes.

Forcing the unit to operate the unit by defeating the safety features of the devices such as the pressure switch or the temperature switch, making unauthorized changes to the switch settings, or using accessories other than the ones recommended by Mitsubishi Electric may result in smoke, fire, or explosion.

To reduce the risk of fire or explosion, do not use volatile or flammable substances as a heat carrier.

To reduce the risk of burns or electric shock, do not touch exposed pipes and wires.

To reduce the risk of shorting, current leakage, electric shock, malfunctions, smoke, or fire, do not splash water on electric parts.

To reduce the risk of burns, do not touch the pipes with bare hands.

To reduce the risk of electric shock, malfunctions, smoke or fire, do not operate the switches/buttons or touch other electrical parts with wet hands.

To reduce the risk of electric shock and injury from the fan or other rotating parts, stop the operation and turn off the main power before cleaning, maintaining, or inspecting the unit.

To reduce the risk of burns or frost bites, do not touch the refrigerant pipes or refrigerant circuit components with bare hands during and immediately after operation.

Before cleaning the unit, switch off the power. (Unplug the unit, if it is plugged in.)

To reduce the risk of injury, keep children away while installing, inspecting, or repairing the unit.

Children should be supervised to ensure that they do not play with the appliance.

This appliance is not intended for use by persons (including children) with reduced physical, sensory or mental capabilities, or lack of experience and knowledge, unless they have been given supervision or instruction concerning use of the appliance by a person responsible for their safety

Keep the space well ventilated. Refrigerant can displace air and cause oxygen starvation.

If leaked refrigerant comes in contact with a heat source, toxic gas may be generated.

Always replace a fuse with one with the correct current rating.

The use of improperly rated fuses or a substitution of fuses with steel or copper wire may result in fire or explosion.

Properly install all required covers and panels on the terminal box and control box to keep moisture and dust out.

Dust accumulation and water may result in electric shock, smoke, or fire.

If any abnormality (e.g., burning smell) is noticed, stop the operation, turn off the power switch, and consult your dealer.

Continuing the operation may result in electric shock, malfunctions, or fire.

Consult an authorized agency for the proper disposal of the unit

Refrigerant oil and refrigerant that may be left in the unit pose a risk of fire, explosion, or environmental pollution.



CAUTION

To reduce the risk of fire or explosion, do not place flammable materials or use flammable sprays around the unit.

Do not operate the unit without panels and safety guards properly installed.

To reduce the risk of injury, do not sit, stand, or place objects on the unit.

Do not connect the makeup water pipe directly to the potable water pipe. Use a cistern tank between them.

Connecting these pipes directly may cause the water in the unit to migrate into the potable water and cause health problems.

To reduce the risk of adverse effects on plants and animals, do not place them where they are directly exposed to discharge air from the unit.

Do not install the unit on or over things that are vulnerable to water damage.

Condensation may drip from the unit.

The model of heat pump unit described in this manual is not intended for use to preserve food, animals, plants, precision instruments, or art work.

To reduce the risk of injury, do not touch the heat exchanger fins or sharp edges of components with bare hands.

Do not place a container filled with water on the unit.

If water spills on the unit, it may result in shorting, current leakage, electric shock, malfunction, smoke, or fire.

Always wear protective gears when touching electrical components on the unit.

Several minutes after the power is switched off, residual voltage may still cause electric shock.

To reduce the risk of injury, do not insert fingers or foreign objects into air inlet/outlet grills. If the unit is left on a damaged base, it may fall and cause injury.

To reduce the risk of injury, wear protective gear when working on the unit.

Do not release refrigerant into the atmosphere. Collect and reuse the refrigerant, or have it properly disposed of by an authorized agency.

Refrigerant poses environmental hazards if released into the air.

To prevent environmental pollution, dispose of brine in the unit or cleaning solutions according to the local regulations.

It is punishable by law not to dispose of them according to the applicable laws.

The water heated by the heat pump is not suitable for use as drinking water or for cooking.

It may cause health problems or degrade food.

In areas where temperature drops to freezing during the periods of non-use, blow the water out of the pipes or fill the pipes with anti-freeze solution.

Not doing so may cause the water to freeze, resulting in burst pipes and damage to the unit or the furnishings.

In areas where temperature drops to freezing, use an anti-freeze circuit and leave the main power turned on to prevent the water in the water circuit from freezing and damaging the unit or causing water leakage and resultant damage to the furnishings.

Use clean tap water.

The use of acidic or alkaline water or water high in chlorine may corrode the unit or the pipes, causing water leakage and resultant damage to the furnishings.

In areas where temperature can drop low enough to cause the water in the pipes to freeze, operate the unit often enough to prevent the water from freezing.

Frozen water in the water circuit may cause the water to freeze, resulting in burst pipes and damage to the unit or the furnishings.

Periodically inspect and clean the water circuit.

Dirty water circuit may compromise the unit's performance or corrodes the unit or cause water leakage and resultant damage to the furnishings.

■ Transportation

 **WARNING**

Lift the unit by placing the slings at designated locations. Support the outdoor unit securely at four points to keep it from slipping and sliding.

If the unit is not properly supported, it may fall and cause personal injury.

 **CAUTION**

To reduce the risk of injury, do not carry the product by the PP bands that are used on some packages.

To reduce the risk of injury, products weighing 20 kg or more should be carried by two or more people.

■ Installation

 **WARNING**

Do not install the unit where there is a risk of leaking flammable gas.

If flammable gas accumulates around the unit, it may ignite and cause a fire or explosion.

Properly dispose of the packing materials.

Plastic bags pose suffocation hazard to children.

The unit should be installed only by personnel certified by Mitsubishi Electric according to the instructions detailed in the Installation/Operation Manual.

Improper installation may result in refrigerant leakage, water leakage, injury, electric shock, or fire.

Periodically check the installation base for damage.

Remove packing materials from the unit before operating the unit. Note that some accessories may be taped to the unit. Properly install all accessories that are required.

Failing to remove the packing materials or failing to install required accessories may result in refrigerant leakage, oxygen starvation, smoke, or fire.

Consult your dealer and take appropriate measures to safeguard against refrigerant leakage and resultant oxygen starvation. An installation of a refrigerant gas detector is recommended.

Any additional parts must be installed by qualified personnel. Only use the parts specified by Mitsubishi Electric.

Take appropriate safety measures against wind gusts and earthquakes to prevent the unit from toppling over and causing injury.

Be sure to install the unit horizontally, using a level.

If the unit is installed at an angle, it may fall and cause injury or cause water leakage.

The unit should be installed on a surface that is strong enough to support its weight.

As an anti-freeze, use ethylene glycol or propylene glycol diluted to the specified concentration.

The use of other types of anti-freeze solution may cause corrosion and resultant water leakage. The use of flammable anti-freeze may cause fire or explosion.

CAUTION

Do not install the unit on or over things that are vulnerable to water damage.

When the indoor humidity exceeds 80% or if the drain water outlet becomes clogged, condensation may drip from the indoor unit onto the ceiling or floor.

All drainage work should be performed by the dealer or qualified personnel according to the instructions detailed in the Installation Manual.

Improper drainage work may cause rain water or drain water to enter the buildings and damage the furnishings.

■ Pipe installation

WARNING

To prevent explosion, do not heat the unit with refrigerant gas in the refrigerant circuit.

Check for refrigerant leakage at the completion of installation.

If leaked refrigerant comes in contact with a heat source, toxic gas may be generated.

CAUTION

Check that no substance other than the specified refrigerant (R407C) is present in the refrigerant circuit.

Infiltration of other substances may cause the pressure to rise abnormally high and cause the pipes to explode.

To keep the ceiling and floor from getting wet due to condensation, properly insulate the pipes.

Piping work should be performed by the dealer or qualified personnel according to the instructions detailed in the Installation Manual.

Improper piping work may cause water leakage and damage the furnishings.

■ Electrical wiring

To reduce the risk of wire breakage, overheating, smoke, and fire, keep undue force from being applied to the wires.

Properly secure the cables in place and provide adequate slack in the cables so as not to stress the terminals.

Improperly connected cables may break, overheat, and cause smoke or fire.

To reduce the risk of injury or electric shock, switch off the main power before performing electrical work.

All electric work must be performed by a qualified electrician according to the local regulations, standards, and the instructions detailed in the Installation Manual.

Capacity shortage to the power supply circuit or improper installation may result in malfunction, electric shock, smoke, or fire.

To reduce the risk of electric shock, smoke, or fire, install an inverter circuit breaker on the power supply to each unit.

Use properly rated breakers and fuses (inverter breaker, Local Switch <Switch + Type-B fuse>, or no-fuse breaker).

The use of improperly rated breakers may result in malfunctions or fire.

To reduce the risk of current leakage, overheating, smoke, or fire, use properly rated cables with adequate current carrying capacity.

Keep the unsheathed part of cables inside the terminal block.

If unsheathed part of the cables come in contact with each other, electric shock, smoke, or fire may result.

Proper grounding must be provided by a licensed electrician. Do not connect the grounding wire to a gas pipe, water pipe, lightning rod, or telephone wire.

Improper grounding may result in electric shock, smoke, fire, or malfunction due to electrical noise interference.

CAUTION

To reduce the risk of current leakage, wire breakage, smoke, or fire, keep the wiring out of contact with the refrigerant pipes and other parts, especially sharp edges.

To reduce the risk of electric shock, shorting, or malfunctions, keep wire pieces and sheath shavings out of the terminal block.

■ Transportation and repairs

WARNING

The unit should be moved, disassembled, or repaired only by qualified personnel. Do not alter or modify the unit.

Improper repair or unauthorized modifications may result in refrigerant leakage, water leakage, injury, electric shock, or fire.

After disassembling the unit or making repairs, replace all components as they were.

Failing to replace all components may result in injury, electric shock, or fire.

If the supply cord is damaged, it must be replaced by the manufacturer, its service agent or similarly qualified persons in order to avoid a hazard.

CAUTION

To reduce the risk of shorting, electric shock, fire, or malfunction, do not touch the circuit board with tools or with your hands, and do not allow dust to accumulate on the circuit board.



IMPORTANT

■ General

To avoid damage to the unit, use appropriate tools to install, inspect, or repair the unit.

To reduce the risk of malfunctions, use the unit within its operating range.

To reduce the risk of malfunction, turn on the power at least 12 hours before starting operation, and leave the power turned on throughout the operating season.

Do not switch on or off the main power in a cycle of shorter than 10 minutes.

Short-cycling the compressor may damage the compressor.

Recover all refrigerant from the unit.

It is punishable by law to release refrigerant into the atmosphere.

To maintain optimum performance and reduce the risk of malfunction, keep the air pathway clear.

Do not unnecessarily change the switch settings or touch other parts in the refrigerant circuit.

Doing so may change the operation mode or damage the unit.

To ensure proper operation of the unit, periodically check for proper concentration of anti-freeze.

Inadequate concentration of anti-freeze may compromise the performance of the unit or cause the unit to abnormally stop.

■ Installation

Take appropriate measures against electrical noise interference when installing the air conditioners in hospitals or facilities with radio communication capabilities.

Inverter, high-frequency medical, or wireless communication equipment as well as power generators may cause the air conditioning system to malfunction. Air conditioning system may also adversely affect the operation of these types of equipment by creating electrical noise.

■ Pipe installation

Check the water system, using a relevant manual as a reference.

Using the system that does not meet the standards (including water quality and water flow rate) may cause the water pipes to corrode.

■ Electrical wiring

To reduce the risk of power capacity shortage, always use a dedicated power supply circuit.

1. Selecting the Installation Site

[1] Installation conditions

Select the installation site in consultation with the client.

Select a site to install the outdoor unit that meets the following conditions:

- The unit will not be subject to heat from other heat sources.
- The noise from the unit will not be a problem.
- The unit will not be exposed to strong winds.
- Water from the unit can be drained properly.
- The space requirements (specified on page 9) are met.

<1> Providing protection against winds

Using the figures at right as a reference, provide adequate protection against winds.

A unit installed alone is vulnerable to strong winds. Select the installation site carefully to minimize the effect of winds. When installing a unit in a place where the wind always blows from the same direction, install the unit so that the outlet faces away from the direction of the wind.

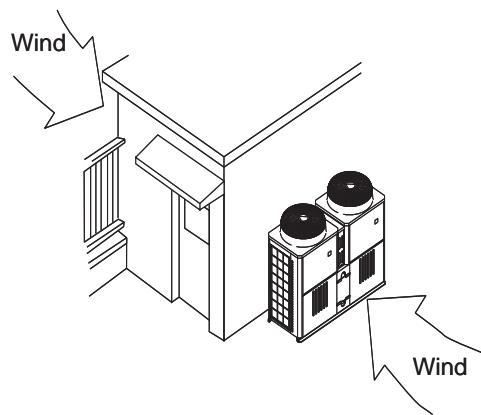

- Install the outdoor unit in a place where it is not exposed to direct wind, such as behind a building.

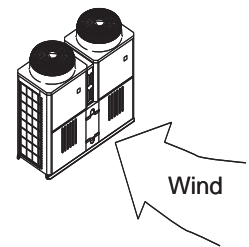

- Install the outdoor unit so that the outlet/inlet faces away from the wind.

<2> Cold Climate Installation

Observe the following when installing the units in areas where snow or strong winds prevail.

- Avoid direct exposure to rain, winds, and snow.
- When deciding the high of the unit stand for snow damage prevention, consider the snow accumulation.
- There is a possibility that an icicle may form under the unit stand. Consider this when installing the unit on the roof for this may injure person or the property.
- If the units are installed in the direct line of rain, winds, or snow, install the optional snow hood (on both the discharge and suction ducts). Use a snow net or snow fence as necessary to protect the unit.
- Install the unit on a base approximately twice as high as the expected snowfall.
- If the unit is continuously operated for a long time with the outside air temperature below the freezing point, install a heater at the base of the unit to prevent the water from freezing at the unit bottom.

[2] Installation space requirements

<1> Single unit installation

Secure enough space around the unit as shown in the figures below.

<Unit: mm>

(1) Walls around the unit do not exceed the height limit.

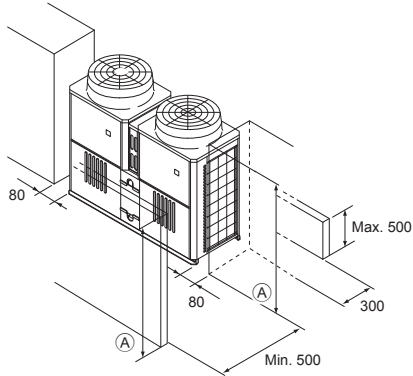

Ⓐ Walls are lower than the unit's height.

(2) There is a wall above the unit.

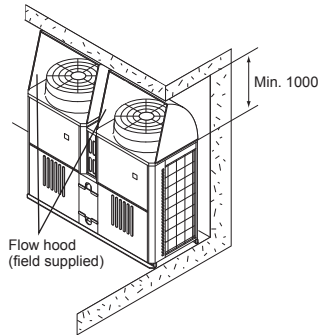
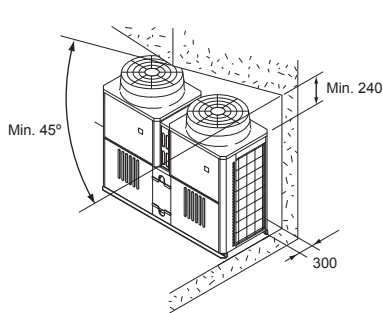

(3) One or more of the walls around the unit are taller than the maximum allowable height <h>.

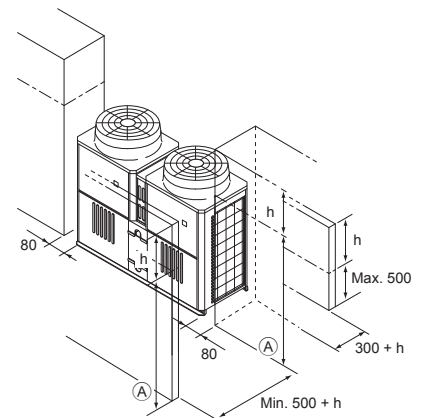
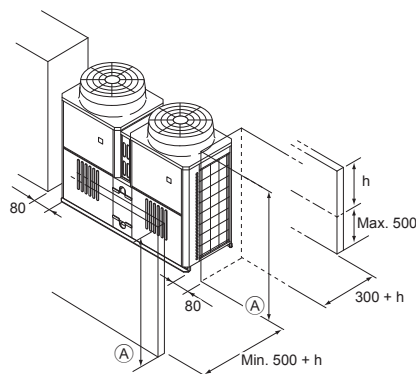
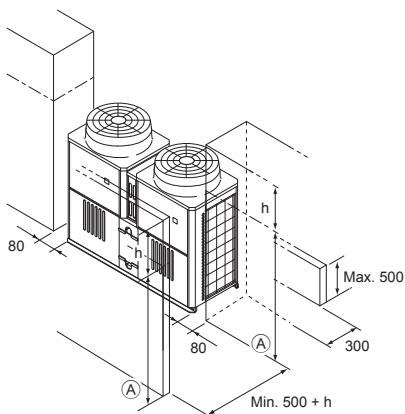

Ⓐ Walls are lower than the unit's height.

(4) Water pipe installation

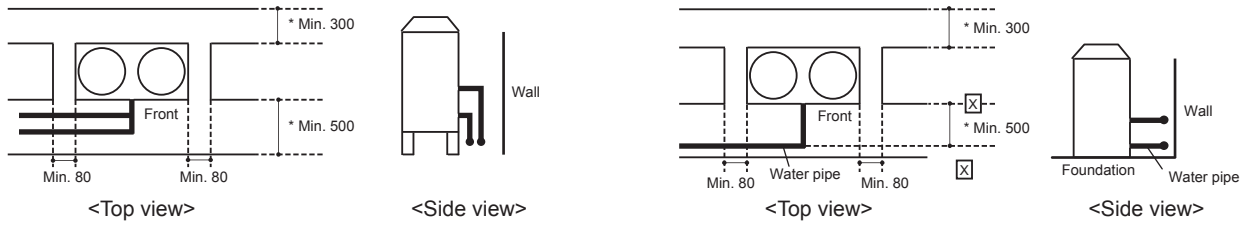

Leave a space of at least 500 between the unit and the water pipe if it is not possible to install the unit on a raised foundation. (SEE ☒ in the figure.)

<2> Grouped and side-by-side installation

When multiple units are installed adjacent to each other, allow enough space for air circulation and a walk way between groups of units as shown in the figures below.

* Leave both sides of each group of units open.

As with individual installation, if the wall height exceeds the height limit, widen the space in the front and the back of a given group of units by the amount that exceeds the limit (labeled h in the figure).

<Unit: mm>

(1) Side-by-side installation

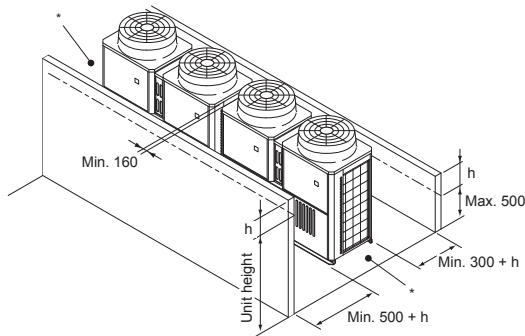

(2) Face-to-face installation

- There are walls in the back and the front of a given group of units.

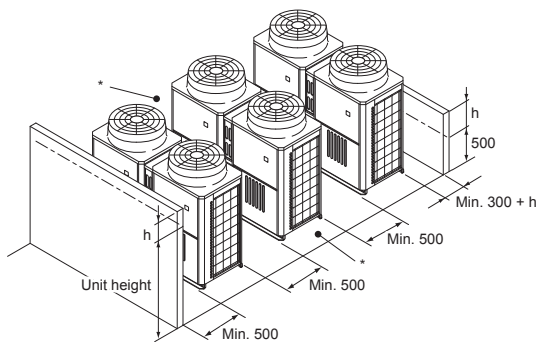

- There is a wall on one side.

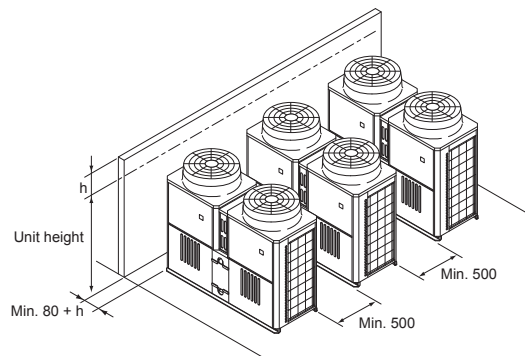

(3) Combination of face-to-face and side-by-side installations

- There are walls in the back and the front of a given group of units.
- There is a wall on one side and either the front or the back of a given group of unit.

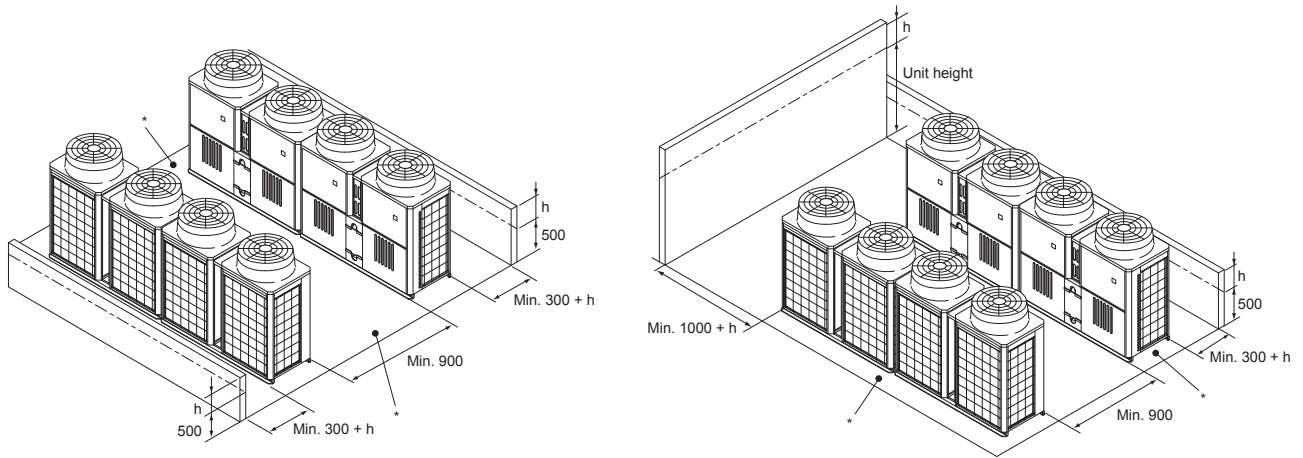

(4) Water pipe installation

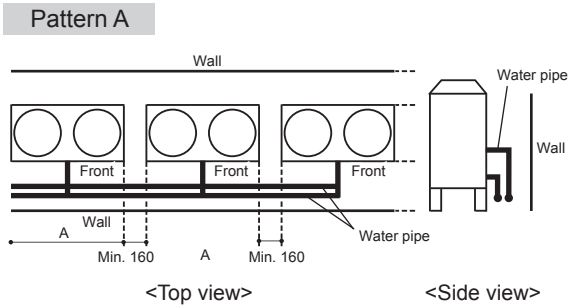

If the product width (labeled A in the figure) times the number of units that are installed side by side exceeds 6 m, leave a space of 1000 mm between each block. Each block is defined as a group of units that fit within 6 m.

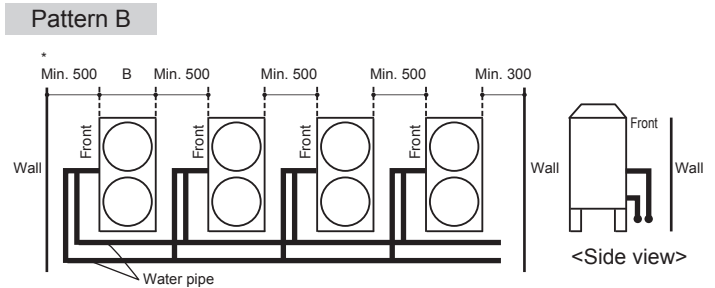

If the product depth (labeled B in the figure) times the number of units that are installed in rows exceeds 6 m, leave a space of 1000 mm between each block. Each block is defined as a group of units that fit within 6 m.

2. Installation of unit

Units should be installed only by personnel certified by Mitsubishi Electric.

- Fix unit tightly with bolts so that unit will not fall down due to earthquakes or strong winds.
- Use concrete or an angle bracket as the foundation of unit.
- Vibration may be transmitted to the installation section and noise and vibration may be generated from the floor and walls, depending on the installation conditions. Therefore, provide ample vibrationproofing (cushion pads, cushion frame, etc.).
- Build the foundation in such way that the corner of the installation leg is securely supported as shown in the figure. When using a rubber isolating cushion, please ensure it is large enough to cover the entire width of each of the unit's legs. If the corners are not firmly seated, the installation feet may be bent.
- The projecting length of the anchor bolt should be less than 30 mm.
- Hole-in anchor bolts are not compatible with this product. However, if fixing brackets are mounted on the 4 locations of the unit attachment part, hole-in anchor bolts can be used.
- The detachable leg can be removed at the site.
- Detaching the detachable leg
Loosen the three screws to detach the detachable leg (Two each in the front and back).
If the base leg finish is damaged when detaching, be sure to repair at the site.

⚠ Warning:

- **Be sure to install unit in a place strong enough to withstand its weight.**
Any lack of strength may cause unit to fall down, resulting in a personal injury.
- **Have installation work in order to protect against strong winds and earthquakes.**
Any installation deficiency may cause unit to fall down, resulting in a personal injury.

When building the foundation, give full attention to the floor strength, drain water disposal <during operation, drain water flows out of the unit>, and piping and wiring routes.

Precautions when routing the pipes and wires below the unit (Without detachable leg)

When routing the pipes and wires below the unit, be sure that the foundation and base work do not block the base through-holes. Also make sure the foundation is at least 100 mm high so that the piping can pass under the unit.

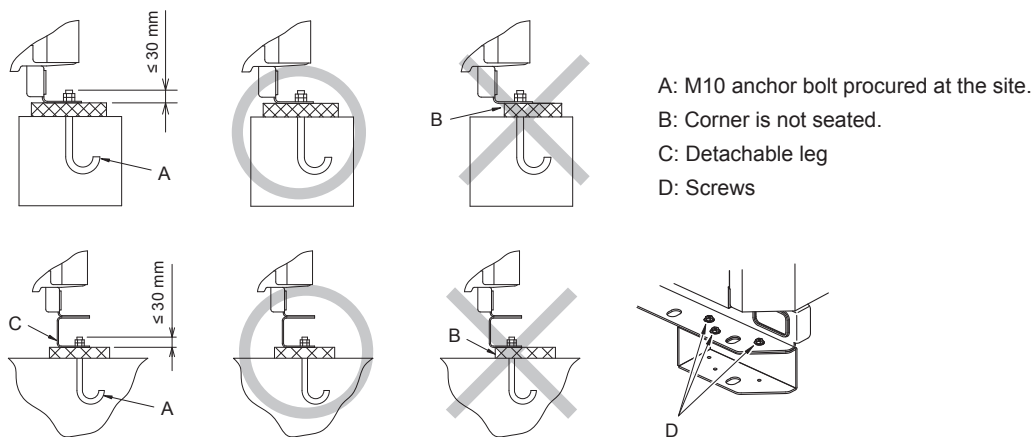

3. Water Pipe Installation

[1] Caution for water pipe installation

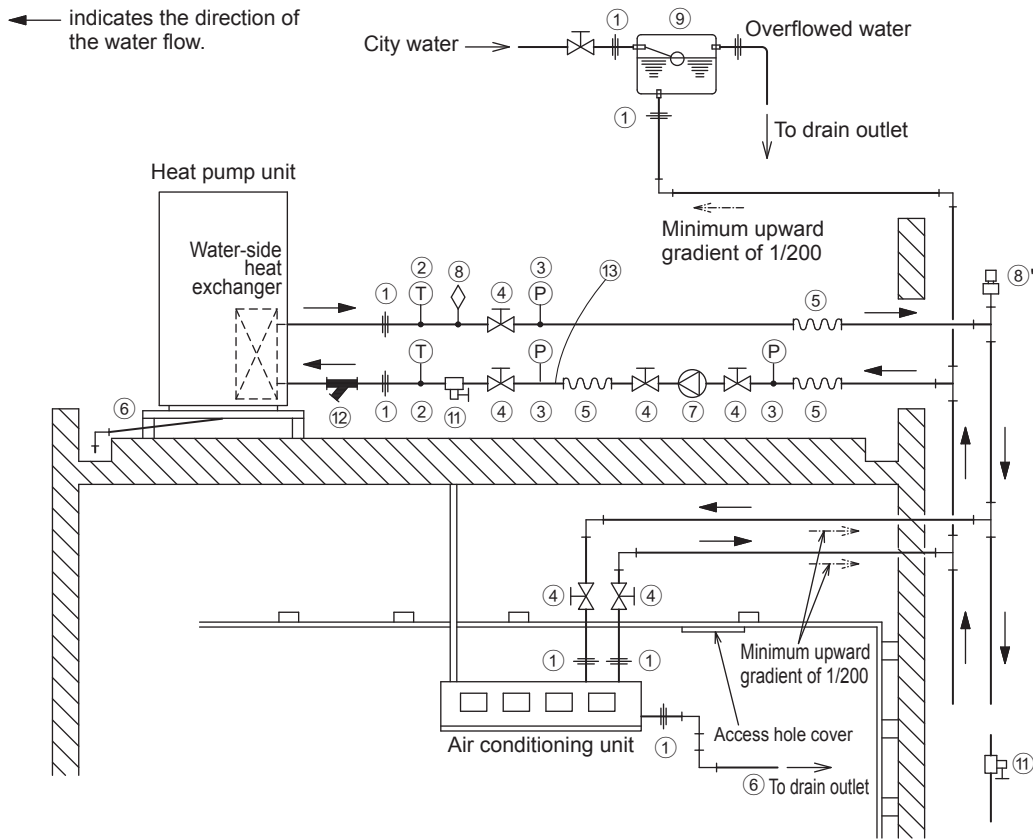

| | |
|-----------------------------------|--|
| ① Union joints/flange joints etc. | Required to allow for a replacement of equipment |
| ② Thermometer | Required to check the performance and monitor the operation of the units. |
| ③ Water pressure gauge | Recommended for checking the operation status. |
| ④ Valve | Required to allow for a replacement or cleaning of the flow adjuster. |
| ⑤ Flexible joint | Recommended to prevent the noise and vibration from the pump from being transmitted. |
| ⑥ Drain pipe | Install the drain pipe with a downward inclination of between 1/100 and 1/200. To prevent drain water from freezing in winter, install the drain pipe as steep an angle as practically possible and minimize the straight line. For cold climate installation, take an appropriate measure (e.g., drain heater) to prevent the drain water from freezing. |
| ⑦ Pump | Use a pump that is large enough to compensate for the total water pressure loss and supply sufficient water to the unit. |
| ⑧ Air vent valve | Install air venting valves to the places where air can accumulate. Automatic air vent valves (such as ⑧') are effective. |
| ⑨ Expansion tank | Install an expansion tank to accommodate expanded water and to supply water. |
| ⑩ Water pipe | Use pipes that allow for easy air purging, and provide adequate insulation. |
| ⑪ Drain valve | Install drain valves so that water can be drained for servicing. |
| ⑫ Strainer | Install a strainer near the unit to keep foreign materials from entering the water-side head exchanger (supplied). |
| ⑬ Flow switch | Required to protect the unit. |

<2> Notes on pipe corrosion

Water processing and water quality control

When the circulating water quality is poor, the water heat exchanger can develop scales, leading to a reduction in heat-exchange power and possible corrosion of the heat exchanger. Please pay careful attention to water processing and water quality control when installing the water circulation system.

- Removal of foreign objects or impurities within the pipes.

During installation, be careful that foreign objects, such as welding fragments, sealant particles, or rust, do not enter the pipes.

- Water Quality Processing

- (1) Depending on the quality of water used, the heat exchanger may become corroded or scaled up. We recommend regular water quality processing.

Water circulation systems using open heat storage tanks are particularly prone to corrosion.

When using an open-type heat storage tank, install a water-to-water heat exchanger, and use a closed-loop circuit on the air conditioner side. If a water supply tank is installed, keep contact with air to a minimum, and keep the level of dissolved oxygen in the water no higher than 1 mg/ℓ.

(2) Water quality standard

| Items | | Lower mid-range temperature water system Water Temp. ≤ 60°C | | Higher mid-range temperature water system Water Temp. > 60°C | | Tendency | |
|------------------------|---|--|-----------------------------|---|-----------------------------|-----------|---------------|
| | | Recirculating water | Make-up water | Recirculating water | Make-up water | Corrosive | Scale-forming |
| Standard items | pH (25 °C) | 7.0 ~ 8.0 | 7.0 ~ 8.0 | 7.0 ~ 8.0 | 7.0 ~ 8.0 | ○ | ○ |
| | Electric conductivity (mS/m) (25 °C) (μs/cm) (25 °C) | 30 or less [300 or less] | 30 or less [300 or less] | 30 or less [300 or less] | 30 or less [300 or less] | ○ | ○ |
| | Chloride ion (mg Cl/ℓ) | 50 or less | 50 or less | 30 or less | 30 or less | ○ | |
| | Sulfate ion (mg SO ₄ ²⁻ /ℓ) | 50 or less | 50 or less | 30 or less | 30 or less | ○ | |
| | Acid consumption (pH4.8) (mg CaCO ₃ /ℓ) | 50 or less | 50 or less | 50 or less | 50 or less | | ○ |
| | Total hardness (mg CaCO ₃ /ℓ) | 70 or less | 70 or less | 70 or less | 70 or less | | ○ |
| | Calcium hardness (mg CaCO ₃ /ℓ) | 50 or less | 50 or less | 50 or less | 50 or less | | ○ |
| Reference items | Ionic silica (mg SiO ₂ /ℓ) | 30 or less | 30 or less | 30 or less | 30 or less | | ○ |
| | Iron (mg Fe/ℓ) | 1.0 or less | 0.3 or less | 1.0 or less | 0.3 or less | ○ | ○ |
| | Copper (mg Cu/ℓ) | 1.0 or less | 1.0 or less | 1.0 or less | 1.0 or less | ○ | |
| | Sulfide ion (mg S ²⁻ /ℓ) | Not to be detected | Not to be detected | Not to be detected | Not to be detected | ○ | |
| | Ammonium ion (mg NH ₄ ⁺ /ℓ) | 0.3 or less | 0.1 or less | 0.1 or less | 0.1 or less | ○ | |
| | Residual chlorine (mg Cl/ℓ) | 0.25 or less | 0.3 or less | 0.1 or less | 0.3 or less | ○ | |
| | Free carbon dioxide (mg CO ₂ /ℓ) | 0.4 or less | 4.0 or less | 0.4 or less | 4.0 or less | ○ | |
| Ryzner stability index | — | — | — | — | ○ | ○ | |

Reference: Guideline of Water Quality for Refrigeration and Air Conditioning Equipment. (JRA GL02E-1994)

- (3) Please consult with a water quality control specialist about water quality control methods and water quality calculations before using anti-corrosive solutions for water quality management.

- (4) When replacing a previously installed air conditioning device (even when only the heat exchanger is being replaced), first conduct a water quality analysis and check for possible corrosion.

Corrosion can occur in water systems even if there has been no prior signs of corrosion.

If the water quality level has dropped, please adjust water quality sufficiently before replacing the unit.

(5) Suspended solids in the water

Sand, pebbles, suspended solids, and corrosion products in water can damage the heating surface of the heat exchanger and cause corrosion. Install a good quality strainer (20 mesh or better) at the inlet of the unit to filter out suspended solids.

Removing foreign substances from the water system

Consider installing a settlement tank or a bypass strainer to remove foreign substances from the water system.

Select a strainer capable of handling two to three percent of the circulating water. The figure below shows a sample system with a bypass strainer.

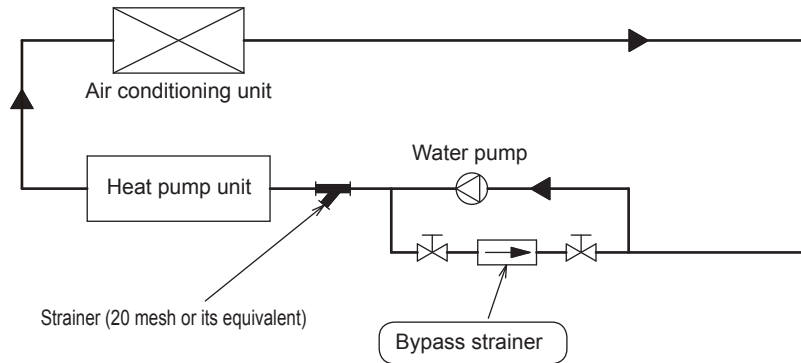

(6) Connecting pipes made from different materials

If different types of metals are placed in direct contact with each other, the contact surface will corrode.

Install an insulating material between pipes that are made of different materials to keep them out of direct contact with each other.

[2] Installing the water pipes

<1> Installing the strainer

Install the supplied strainer on the inlet water pipe near the unit to filter out suspended solids and prevent clogging or corrosion of the heat exchanger.

Install the strainer in a way that allows for easy access for cleaning, and instruct the user to clean it regularly.

Operating the units with a clogged strainer may cause the units to make an abnormal stop.

Select a location to install a strainer, taking into consideration the installation angle, insulation thickness, and maintenance space.

* The dimensions given below indicate the amount of space necessary when screwing in a Y-shaped strainer.

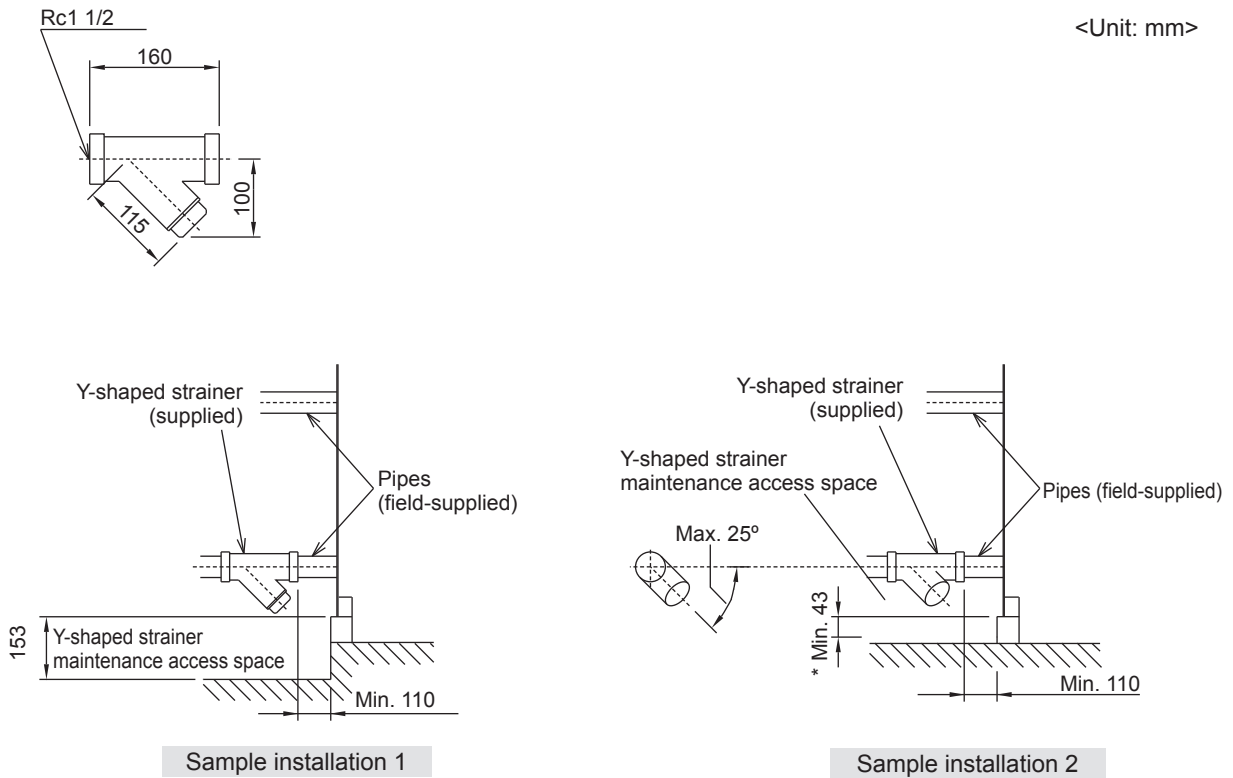

<2> Installing a flow switch

Install a flow switch that meets the following specifications on the water pipe.

Connect the flow switch to the flow switch contact on the unit.

Minimum flow rate= 7.5 m³/h (125 L/min)

Unit usage range (water flow rate): 7.5 - 15.0 m³/h

[3] Water pipe hole size and location

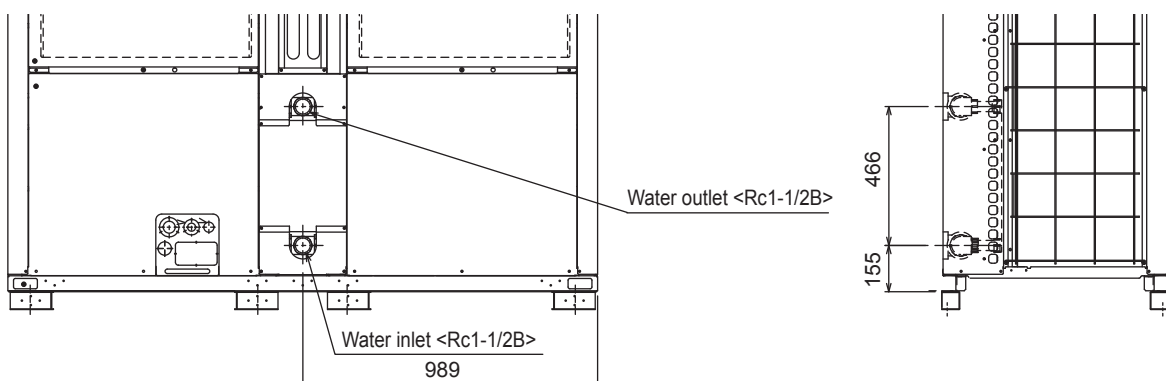

4. System Configurations

[1] System Configuration

(1) Individual system

- Each unit is operated individually by connecting a dry contact switch/relay to each unit.

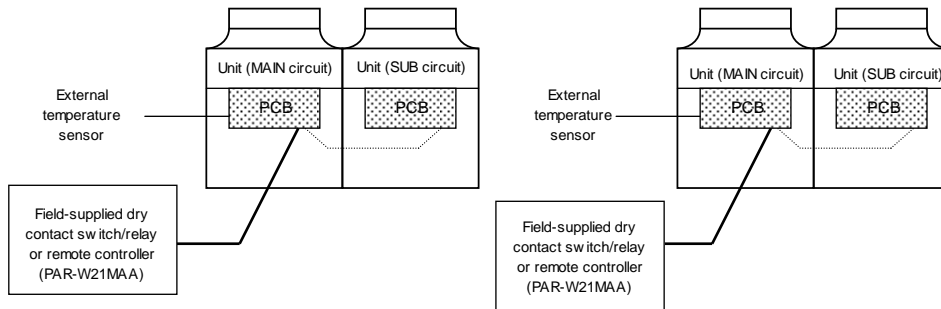

Refer to the sections "Configuring the System" on the next page and "System configuration procedures: Individual System" for further details.

(2) Multiple system (2-16 units)

- A group of unit that consists of one main unit and up to 15 sub units is operated collectively by connecting a representative water temperature sensor and a dry contact switch/relay to the main unit.

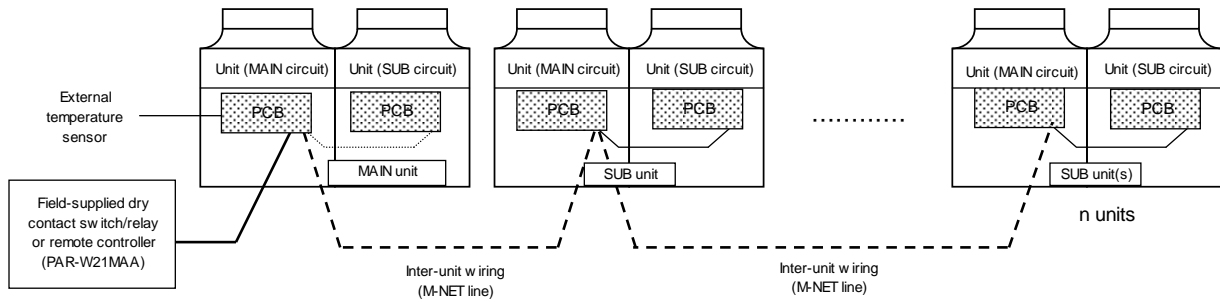

Refer to the sections "Names and functions of the switches" on the next page and "System configuration procedures: Multiple System" for further details.

[2] Configuring the System

(1) Switch names and functions

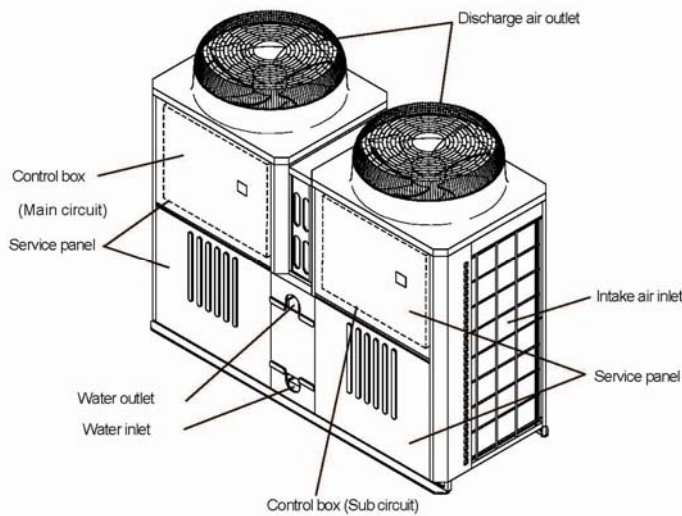

There are four main ways to set the settings as follows:

- ① Dip switches (SW1 - SW3)
- ② Dip switches used in combination with the push switches
- ③ Rotary switches
- ④ Slide switches

See below for how these switches are used to set certain items.

Different types of switches on the PCB

[Entire view of a PCB]

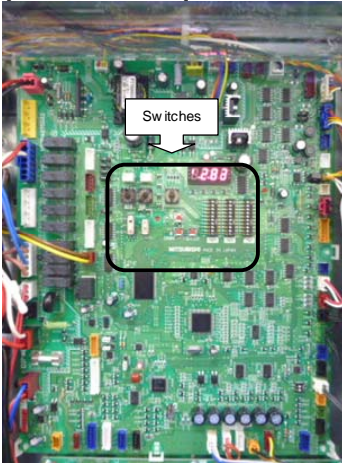

- Rotary switch (SWU3) (0-F)
- Rotary switch (SWU2) (0-9)
- Rotary switch (SWU1) (0-9)
- Slide switch (SWS1) (LOCAL, OFF, and REMOTE from the top)
- Slide switch (SWS2) (A and B from the top)
- Push switch (SWP1) "UP"
- Push switch (SWP2) "DOWN"
- Push switch (SWP3) "ENTER"

[Enlarged view of the switches]

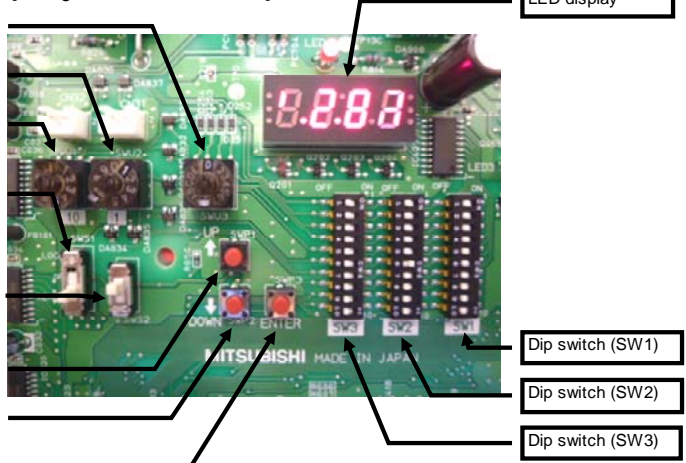

| | | Initial Setting | |
|----------------------|--|-----------------|-------------|
| | | MAIN circuit | SUB circuit |
| Rotary switch (SWU1) | Sets the 10's digit of the unit address (Simple group operation). | "0" | "5" |
| Rotary switch (SWU2) | Sets the 1's digit of the unit address (Simple group operation). | "1" | "1" |
| Rotary switch (SWU3) | Starts up or resets the system (when set to F). | "0" | "0" |
| Slide switch (SWS1) | LOCAL OFF REMOTE The action that the switch takes when set to a certain position depends on the type of system configuration (e.g., individual operation, simple group operation) | REMOTE | REMOTE |
| Slide switch (SWS2) | Unused | A | A |
| Push switch (SWP1) | Switches the display between the item code and the current value for a specific item. Increases value. | - | - |
| Push switch (SWP2) | Switches the display between the item code and the current value for a specific item. Decreases value. | - | - |
| Push switch (SWP3) | Advances the item code. Saves the changed value. | - | - |
| Dip switches (SW1-3) | Switches the LED display contents. | | |

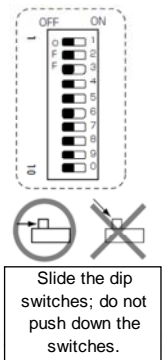

(2) Factory Switch Settings (Dip switch settings table)

| SW | Function | Usage | Factory setting | | OFF setting | ON setting | Setting timing | |
|------|----------|--|---|-------------|--|--|---|------------|
| | | | MAIN circuit | SUB circuit | | | | |
| SW01 | 1 | Model setting | Depends on the unit | - | Leave the setting as it is. | | At a reset | |
| | 2 | | | | | | | |
| | 3 | | | | | | | |
| | 4 | | | | | | | |
| | 5 | | | | | | | |
| | 6 | | | | | | | |
| | 7 | | | | | | | |
| | 8 | | | | | | | |
| | 9 | | | | | | | |
| | 10 | | | | | | | |
| SW02 | 1 | Freeze-up protection setting | OFF | - | Starts the pump when both the outside and water temperatures drop to prevent water pipe freeze up. | - | At a reset | |
| | 2 | Scheduled operation display | Turns on and off the remote display during scheduled operation. | OFF | - | Turns off the operation display during the period in which the unit is scheduled to be stopped. | Leaves the operation display on during the period in which the unit is scheduled to be stopped. | At a reset |
| | 3 | Model setting | | OFF | - | Leave the setting as it is. | | At a reset |
| | 4 | Model setting | | OFF | - | Leave the setting as it is. | | At a reset |
| | 5 | Recovery conditions after forced stoppage | Selects what the operation restoration condition will be based on after the unit was forced to stop based on the external thermistor reading (water outlet temperature). | OFF | - | External thermistor | Built-in thermistor | At a reset |
| | 6 | Power supply option to the communication circuit | Switches between supplying or not supplying power to the communication circuit. | - | ON | Supplies power to the communication circuit. | Does not supply power to the communication circuit. | Any time |
| | 7 | Remote water-temperature setting | Allows or disallows the water temperature to be set using analog signals from a remote location. | OFF | - | Disallows the water temperature to be set using external analog signals. | Allows the water temperature to be set using external analog signals. | At a reset |
| | 8 | Water-temperature control option | Selects either the representative water temperature sensor or the built-in sensor to be used to control water temperature. | OFF | - | Built-in sensor on the unit | External water temperature sensor | At a reset |
| | 9 | Individual/Multiple system | Selects between individual and Multiple system | OFF | - | Individual control | Multiple system | At a reset |
| | 10 | Display mode switch 7 | These switches are used in combination with dip switches SW03-5 through 3-10 and push switches SWP 1, 2, and 3 to configure or view the settings when performing a test run or changing the system configuration. | OFF | - | Changes the 7-segment LED display mode. | | Any time |
| SW03 | 1 | Remote reset | Enables or disables the error to be reset from a remote location. | ON | - | Disables the error to be reset from a remote location. | Enables the error to be reset from a remote location. | At a reset |
| | 2 | Auto restart after power failure | Enables or disables the automatic restoration of operation after power failure (in the same mode as the unit was in before a power failure). | ON | - | An alarm will be issued when power is restored after a power outage. The alarm will be reset when the power is turned off and then turned back on. | Automatically restores operation after power failure. | At a reset |
| | 3 | Water-temperature control | Switches between inlet-water-temperature-based control and outlet-water-temperature-based control. | OFF | - | Outlet-water-temperature-based control | Inlet-water-temperature-based control | At a reset |
| | 4 | Pump-thermistor interlock setting | Interlocks or does not interlock the operation of the pump with the external thermistor. (Effective only when SW02-8 is set to ON.) | OFF | - | The pump turns on when the operation switch is turned on regardless of the Thermo-ON/Thermo-OFF status. | Interlocks the operation of the pump with the Thermo-ON/Thermo-OFF status. | At a reset |
| | 5 | Display mode switch 1 | These switches are used in combination with dip switches SW02-5 and push switches SWP 1, 2, and 3 to configure or view the settings when performing a test run or changing the system configuration. | OFF | - | Changes the 7-segment LED display mode. | | Any time |
| | 6 | Display mode switch 2 | | OFF | - | Changes the 7-segment LED display mode. | | Any time |
| | 7 | Display mode switch 3 | | OFF | - | Changes the 7-segment LED display mode. | | Any time |
| | 8 | Display mode switch 4 | | OFF | - | Changes the 7-segment LED display mode. | | Any time |
| | 9 | Display mode switch 5 | | OFF | - | Changes the 7-segment LED display mode. | | Any time |
| | 10 | Display mode switch 6 | | OFF | - | Changes the 7-segment LED display mode. | | Any time |

"-" in the table indicates that the function in the corresponding row will be disabled regardless of the actual switch setting. The factory setting for these items is OFF. Refer to page 26 for how to reset errors.

[3] Setting the Operating Conditions (time and water temperature)

The settings must be set only by a qualified personnel.

<1> Making the settings

Use the LED display and the three push switches (SWP1(↑), SWP2(↓), and SWP3(Enter)) to change the current settings on the circuit board and to monitor various monitored values.

(1) Setting Procedures

Take the following steps to set the push switches SWP1 through SWP3. These switches must be set after the dip switches SW2 and SW3 have been set.

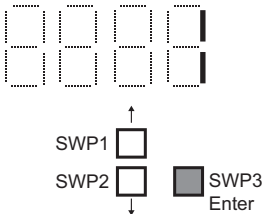
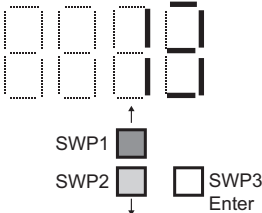
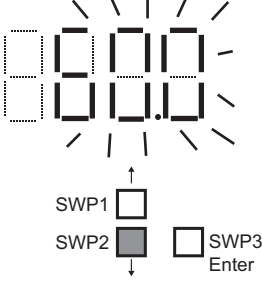
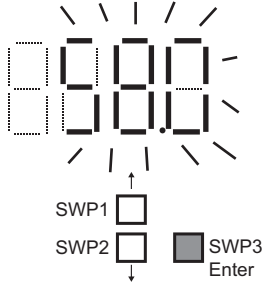
- ①
- 
- Normally an item code appears on the display.
(The figure at left shows the case where item code 1 is displayed.) Press SWP3 (Enter) to advance the item code.
- ↓
- Press SWP3 (Enter) until the item code appears that corresponds to the item to change or monitor its value.
- ②
- 
- The left figure shows a display example (Code 13 Built-in thermistor temperature setting 2).
- ↓
- Press either SWP1 (↑) or SWP2 (↓) to display the value that corresponds to the selected item.
- ③
- 
- The current setting value will blink.
- ↓
- The left figure shows that the current setting value is "60.0."
To decrease this value to 58.0, for example, press SWP2 (↓).
Press SWP1 (↑) to increase the value.
- ④
- 
- <To change the settings>**
When the desired value is displayed (58.0 in the example at left), press SWP3 (Enter).
- ↓
- The displayed value will stop blinking and stay lit.
A lit LED indicates that the new setting has been saved.
- * Pressing SWP1 (↑) or SWP2 (↓) will change the blinking setting value, but the change will not be saved until SWP3 (Enter) is pressed.
If SWP3 is not pressed within one minute, the change will not be saved and the display will return to the item code display mode.
Press and hold SWP1 (↑) or SWP2 (↓) for one second or longer to fast forward through the numbers.
- <To view the monitored data>**
Press SWP3 (Enter) while the LED display is blinking (see step 3 above) to stop the blinking.
- * The values of the items that can only be monitored will not change when SWP1 (↑) or SWP2 (↓) is pressed.
- The display will stop blinking and stay lit after a minute, and the display will automatically return to the item code display regardless of the type of values displayed.
To change the values of other items, repeat the steps from step 2 above.

(2) Table of settings items

HPB System Setting Value

| SW2 and SW3 settings for changing | | | | Setting Item | Item Code | Default | NOTES |
|--|-------|-------|--------|---|-----------|-----------------------------------|---|
| SW2-1 | SW3-8 | SW3-9 | SW3-10 | | | | |
| OFF | OFF | ON | OFF | Booster heater operation temperature | 1052 | 10°C | |
| | | | | Maximum peak-demand capacity | 2 | 100% | |
| | | | | Peak-demand control start time | 3 | | |
| | | | | Peak-demand control end time | 4 | | |
| | | | | Remote water temperature input signal type | 21 | | |
| | | | | Setting temp D,E for analog input | 11 | D=60°C,E=45°C | |
| | | | | Setting temp A (Heating mode) | 11 | 45°C | Range 25-70 |
| | | | | Setting temp B (Hotwater mode) | 13 | 60°C | Range 25-70 |
| | | | | Setting temp C1,C2,C3,C4 for Setting temp C at Heating Eco mode | 22-25 | C1=60°C,C2=0°C C3=35°C,C4=25°C | |
| | | | | Enable/disable schedule setting | 5 | | Set to "1" to enable scheduled operation. |
| | | | | On tme 1 (at schedule mode without remote) | 6 | 0:00 | |
| | | | | OFF time 1 (at schedule mode without remote) | 7 | 0:00 | |
| | | | | On tme 2 (at schedule mode without remote) | 8 | 0:00 | |
| | | | | OFF time 2 (at schedule mode without remote) | 9 | 0:00 | |
| | | | | On tme 3 (at schedule mode without remote) | 18 | 0:00 | |
| OFF time 3 (at schedule mode without remote) | 19 | 0:00 | | | | | |
| OFF | ON | OFF | OFF | Setting temp select1 (Ontime1-Offtime1) | 1218 | A (1) | A or B or C. you can select |
| | | | | Setting temp select2 (Ontime2-Offtime2) | 1219 | A (1) | A or B or C. you can select |
| | | | | Setting temp select3 (Ontime3-Offtime3) | 1220 | A (1) | A or B or C. you can select |
| | | | | Control Sensor select (at Target Setting temp | 1215 | TH15 | TH14 or TH15. you can select |
| | | | | Control Sensor select (at Target Setting temp | 1216 | TH15 | TH14 or TH15. you can select |
| | | | | Control Sensor select (at Target Setting temp | 1217 | TH15 | TH14 or TH15. you can select |
| | | | | Thermo differential 2 | 1016 | | Range 0-8 |
| | | | | Multipule System Thermo-ON/OFF prohibition periods | 1020 | | Range 1-5 |

(3) System configuration procedures: Individual system

1. Set the dip switches on the MAIN circuit board.

Switch settings on the MAIN circuit

Set the dip switches (labeled A in the figure at right) that correspond to the items below, according to the local system.

- Water temperature control based on the representative water temperature reading
- Water temperature control based on the inlet water temperature

Refer to "Dip switch settings table" (page 19) for further details.

Unit (MAIN circuit)

Unit (SUB circuit)

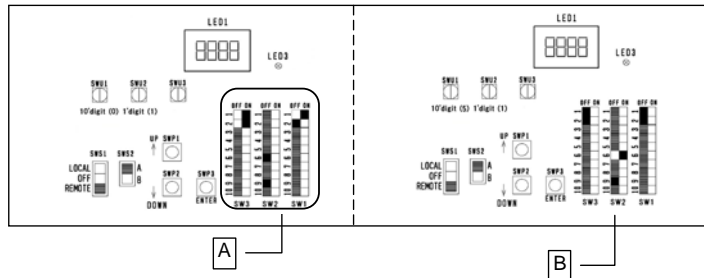

If the system is not started up for five minutes after the power is turned on (with the [EEEE] being displayed on the MAIN circuit), an error code [6500] or [7133] will appear on the SUB circuit. This error code will automatically light off once the system startup procedure is completed.

2. Switch on the power to the unit.

Check for loose or incorrect wiring, and then switch on the power to the unit.

When the power is switched on, the following codes will appear on the LED:

- [EEEE] will appear on LED1 in the MAIN circuit board (labeled A in the figure at right).
- [9999] will appear on LED1 in the SUB circuit board (labeled B in the figure at right).

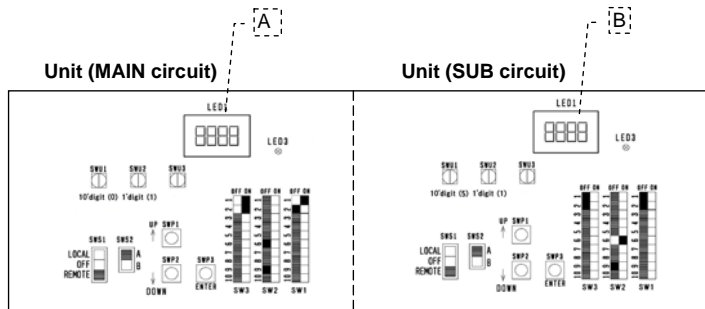

3. Set the preset values with the switches on the MAIN circuit

- Press either one of the push switches SWP1, 2, or 3 (labeled A in the figure at right) on the MAIN circuit board.
* [EEEE] will disappear, and an item code ([101]) will appear on LED1 (labeled B in the figure at right).
- Use SWP3 to toggle through the item codes and select an item code to change its current value. (The item codes will appear in the following order: [101]→[102]→[104]→[105]→[107]→[101] (back to the beginning).)
- Use SWP1 to increase the value and SWP2 to decrease the value.
- Press SWP3 to save the changed value.

Following the steps above, set the value for the following items as necessary.

- [101] Not used
- [102] Not used
- [104] Not used
- [105] Not used
- [107] Total number of units in the system (Default = 1)(Leave it as it is.)

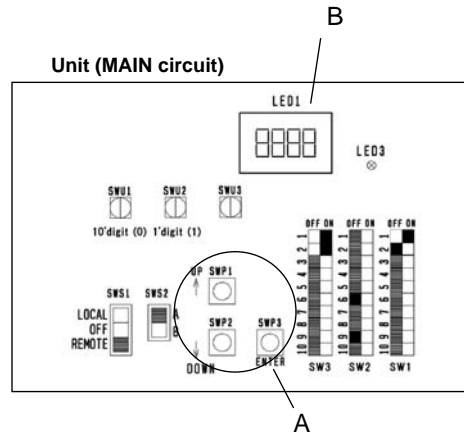

4. Perform an initial setup. (MAIN circuit side)

- Set the rotary switch SWU3 (labeled A in the figure at right) to "F". [EEEE] will appear in the LED1 (labeled B in the figure). *1
- Press and hold the push switch (SWP3)(labeled C in the figure) for one
 - While the system is starting up [9999] will appear on LED1 (labeled B in the figure at right).
 - When start-up is complete, a control property [0012] will appear.
 - Then five seconds later [FFFF] will appear.
- Set the rotary switch SWU3 (labeled A in the figure) back to "0."

The start-up process is complete, and the settings for such items as clock, peak-demand control, schedule, and thermistor settings can now be made.

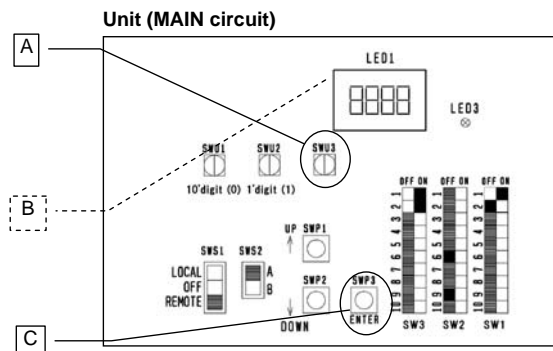

*1 If the start-up process has already been completed, [FFFF] (instead of [EEEE]) will appear when the rotary switch SWU3 is set to "F."

(4) System configuration procedures : Multiple system

1. Set the dip switches and rotary switches.
 (Switches on the MAIN circuit on the main unit* AND the MAIN and SUB circuits on all sub units) on the sub unit)

System configuration

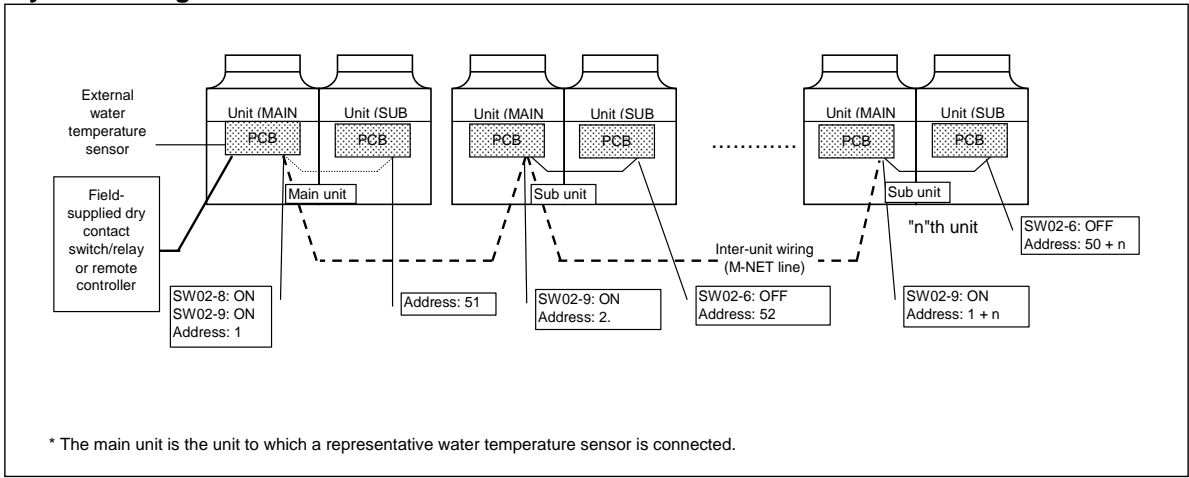

Setting the switches on the main unit

MAIN circuit

- (1) Set the dip switch SW02-8 to ON. (representative water temperature) (labeled A in the figure at right)
- (2) Set the dip switch SW02-9 to ON. (multiple unit control)(labeled A in the figure at right)

SUB circuit

Nothing needs to be changed.

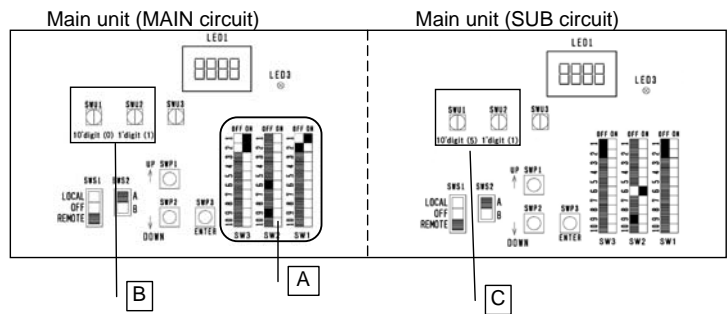

Refer to "Dip switch settings table" (page 19) for further details.

Make sure the address of the MAIN circuit on the main unit is set to "1"(labeled B in the figure above) and that the address of the SUB circuit on the main unit is set to "51" (labeled C in the figure above). The address of each SUB circuit should equal the sum of the MAIN circuit address on the same unit and 50.

Setting the switches on all sub units

MAIN circuit

- (1) Set the dip switch SW02-9 to ON. (multiple unit control)(labeled A in the figure at right)
- (2) Set the MAIN circuit addresses with the rotary switches. (labeled B in the figure at right). Set the 10's digit with SWU1, and set the 1's digit with SWU2. Assign sequential addresses to the MAIN circuit on all sub units starting with 2.

SUB circuit

- (3) Set the dip switch W02-6 to OFF. (power supply to communication circuit) (labeled C in the figure at right)
- (4) Set the SUB circuit addresses with the rotary switches (labeled D in the figure at right). Set the 10's digit with SWU1, and set the 1's digit with SWU2. Assign sequential addresses to the SUB circuit on all sub units

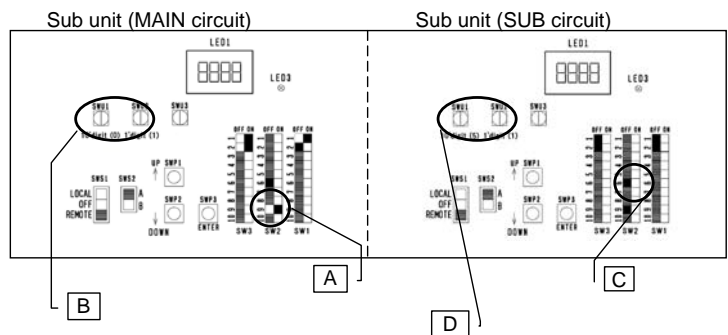

2. Switch on the power to the unit.

Check for loose or incorrect wiring, and then switch on the power to all units.

When the power is switched on, the following codes will appear on the LED:

- [E E E E] will appear on LED1 in the MAIN circuit board
- [9999] will appear on LED1 in the SUB circuit board on the main unit and both MAIN and SUB circuits on the sub units.

If the system is not started up for five minutes after the power is turned on (with the [E E E E] being displayed on the MAIN circuit), an error code [6500] or [7133] will appear on the SUB circuit. This error code will automatically light off once the system startup procedure is completed.

3. Set the preset values with the switches on the MAIN circuit

- Press either one of the push switches SWP1, 2, or 3 (labeled A in the figure at right) on the MAIN circuit board.
 - * [E E E E] will disappear, and an item code ([101]) will appear on LED1 (labeled B in the figure at right).
- Use SWP3 to toggle through the item codes, and select an item code to change its current value. (The item codes will appear in the following order: [101] → [102] → [104] → [105] → [107] → [101] (back to the beginning).)
- Use SWP1 to increase the value and SWP2 to decrease the value.
- Press SWP3 to save the changed value.

Following the steps above, set the value for the following items with the switches on the MAIN circuit as necessary. Item [107] must be set when multiple units are connected to a system.

- [101] Not used
- [102] Not used
- [104] Not used
- [105] Not used
- [107] Total number of the main and sub units in the system

4. Perform an initial setup on the MAIN circuit on the main

- Set the rotary switch SWU3 on the MAIN circuit on the main unit (labeled A in the figure at right) to "F."

[E E E E] will appear in the LED1 (labeled B in the figure). *1

- Press and hold the push switch (SWP3) (labeled C in the figure) for one second or longer.

- While the system is starting up [9999] will appear on LED1 (labeled B in the figure at right).
- When start-up is complete, a control property [0012] will appear.
- Then, five seconds later, [F F F F] will appear.

- Set the rotary switch SWU3 (labeled A in the figure) back to "0."

The start-up process is complete, and the settings for such items as clock, peak-demand control, schedule, and thermistor settings can now be made.

*1 If the start-up process has already been completed, [F F F F] (instead of [E E E E]) will appear when the rotary switch SWU3 is set to "F."

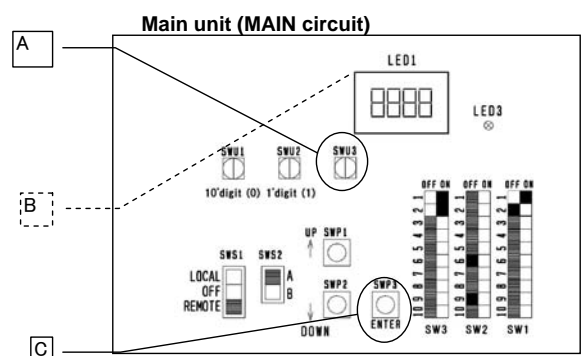
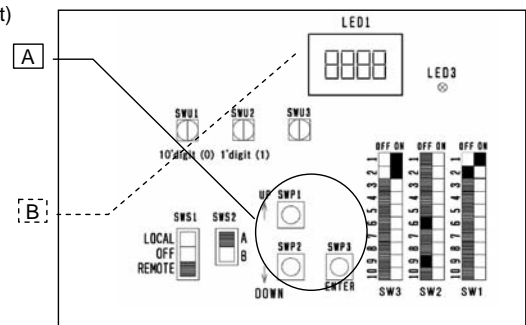
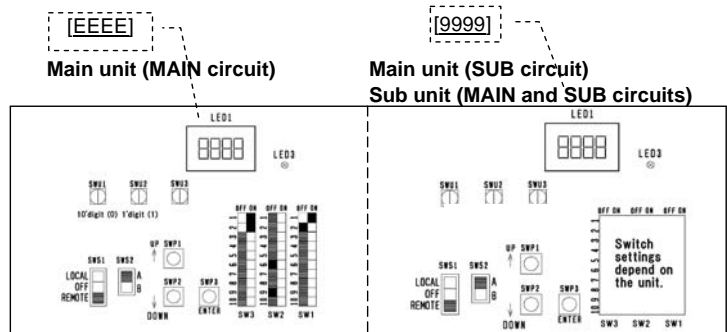

Slide switch (SWS1) settings

Individual system

| SWS1 Setting | | Unit Operation | |
|--------------|-------------|--|--|
| MAIN circuit | SUB circuit | MAIN circuit | SUB circuit |
| Local | LOCAL | Follows the input signal of the MAIN circuit | Follows the input signal of the sub circuit |
| | OFF | | Ignores the signal input |
| | REMOTE | | Follows the input signal of the sub circuit |
| OFF | LOCAL | Ignores the signal input | Ignores the signal input |
| | OFF | | |
| | REMOTE | | |
| REMOTE | LOCAL | Follows the input signal fed through a dry contact interface | Follows the input signal of the MAIN circuit |
| | OFF | | Ignores the signal input |
| | REMOTE | | Follows the input signal of the MAIN circuit |

Multiple system (SWS1 in the SUB circuit on both the main and sub units will be ineffective.)

| SWS1 Setting | | Unit Operation | | | |
|------------------------|-----------------------|---|---|--|--|
| Main unit MAIN circuit | Sub unit MAIN circuit | Main unit MAIN circuit | Main unit SUB circuit | SUB unit MAIN circuit | SUB unit SUB circuit |
| LOCAL | LOCAL | Follows the input signal of the MAIN circuit on the Main unit | Follows the input signal of the MAIN circuit on the Main unit | Follows the input signal of the MAIN circuit on the Sub unit | Follows the input signal of the MAIN circuit on the Sub unit |
| | OFF | | | Ignores the signal input | |
| | REMOTE | | | Follows the input signal of the MAIN circuit on the Sub unit | |
| OFF | LOCAL | Ignores the signal input | | Ignores the signal input | |
| | OFF | | | | |
| | REMOTE | | | | |
| REMOTE | LOCAL | Follows the input signal fed through a dry contact interface | Follows the input signal of the MAIN circuit on the Main unit | | |
| | OFF | | Ignores the signal input | | |
| | REMOTE | | Follows the input signal of the MAIN circuit on the Main unit | | |

(5) Re-initializing the system

When the settings for the items below have been changed, the system will require re-initialization.

- Dip switch SW02-8 (use or non-use of representative water temperature) (Re-initialization is required only when Simple Group Operation is used.)
- Dip switch SW02-9 (multiple unit control)
- Dip switch SW03-3 (water temperature control method)
- External signal input setting [107] (total number of units in the system)
- Rotary switches (SWU1 and SWU2) (unit address)

Take the following steps to re-initialize the system:

- (1) Set the rotary switch SWU3 to "F."
[FFFF] will appear in the LED1.
- (2) Press and hold the push switch (SWP3) for one second or longer.
 - While the system is starting up [9999] will appear on LED1 (labeled B in the figure at right).
 - When start-up is complete, a control property [0022] will appear.
 - Then, five seconds later, [FFFF] will appear.
- (3) Press and hold the push switch (SWP3) again for one second or longer.
 - While the system is starting up [9999] will appear on LED1 (labeled B in the figure at right).
 - When start-up is complete, a control property [0022] will appear.
 - Then, five seconds later, [FFFF] will appear.
- (4) Set the rotary switch SWU3 back to "0."

(6) Resetting the system (MAIN and SUB circuits)

Take the following steps to reset the system. An error can also be reset by taking the steps below.

Note that the errors on the MAIN unit must be reset through the MAIN circuit, and the errors on the sub unit must be reset through the SUB circuit. When an error on the MAIN unit is reset, all sub units will stop.

- (1) Set the rotary switch SWU3 to "F."
[FFFF] will appear in the LED1.
- (2) Press and hold the push switch (SWP3) for one second or longer.
 - While the system is starting up [9999] will appear on LED1 (labeled B in the figure at right).
 - When start-up is complete, a control property [0022] will appear.
 - Then, five seconds later, [FFFF] will appear.
- (3) Set the rotary switch SWU3 back to "0."

The Sensor and Target Temp of HPB System

| Remote | | | | <u>Condition of mode</u> | | Main board of HPB (schedule) | <u>What degree</u> | <u>Where</u> |
|---------------------------------|---|-----------|------------------------------|--------------------------|--------------------------------|--------------------------------|---------------------------------|-------------------------------|
| analog input (SW2-7 ON Setting) | | | Remote controller PAR-W21MAA | | | | | |
| | Heating | Hot Water | manual | schedule | | | | |
| setting | Analog input priority | | | | | | By analog input | TH15 only |
| no-setting | Main board of HPB schedule priority (no using remote controller (*1)) | | | | | setting | Setting temp A~C you can select | TH14 or TH15 (you can select) |
| | ON | ON | non voltage priority | | No-setting | Setting temp B (Hotwater mode) | TH14 or TH15 (you can select) | |
| | ON | OFF | non voltage priority | | | Setting temp C (Heating Eco) | TH14 or TH15 (you can select) | |
| | OFF | ON | non voltage priority | | | Setting temp B (Hotwater mode) | TH14 or TH15 (you can select) | |
| | OFF | OFF | no using remote controller | | | Setting temp A (Heating mode) | TH14 or TH15 (you can select) | |
| | | | Hot water mode | | Setting temp B (Hotwater mode) | TH14 or TH15 (you can select) | | |
| | | | Heating ECO mode | | Setting temp C (Heating Eco) | TH14 or TH15 (you can select) | | |
| | | | Heating | | Setting temp A (Heating mode) | TH14 or TH15 (you can select) | | |
| | | | | setting | according to | TH15 only | | |

<2> Major control items and their settings

Described below is how to make various settings on the heat pump unit's circuit board.

Refer to the Instructions Manual for how to use the optional remote controller.

(1) Water-temperature setting

Different water temperature settings can be set for different modes. Use item codes 11, 13, 22, 23, 24, or 25 to set the water temperatures.

Setting procedures

Set the dip switches on the circuit board as follows before making the settings for the items described in this section.

Step 0

Set the ON/OFF switch (SWS1) to OFF.

Set SWS1 to OFF from the remote controller or with the local switch.

Most settings (other than item codes 11 and 13 (water temperature setting)) cannot be changed unless the ON/OFF setting is set to OFF. *

* Settings can be changed from the optional remote controller, regardless of the ON/OFF status of the operation switch.

Step 1

Set the dip switches SW02 and SW03.

| SW02 | SW03 | | | | | |
|------|------|-----|-----|-----|----|-----|
| -10 | 5 | 6 | 7 | 8 | 9 | 10 |
| OFF | OFF | OFF | OFF | OFF | ON | OFF |

Step 2

Select the desired item with the push switch SWP3.

Item codes 1, 11, 13, 22, 23, 24, and 25 relate to water-temperature setting.

Press the push switch SWP3 to select an item code.

Press the push switches SWP1 and SWP2 to change the value of the selected item.

The value will keep blinking while it is being changed.

Step 3

Press the push switches SWP1 (↑) or SWP2 (↓) to increase or decrease the value.

Settings table

| Items that can be set | Item code | Initial value | Unit | Setting | | | Notes | Setting change from an optional remote controller (PAR-W21MAA) |
|---|-----------|---------------|------|------------|-------------|-------------|-------|--|
| | | | | Increments | Lower limit | Upper limit | | |
| Water temp. setting A (Heating mode) | 11 | 60 | °C | 0.1°C | 25 | 70 | | Possible |
| Water temp. setting B (Hot water mode) | 13 | 65 | °C | 0.1°C | 25 | 70 | *1 | Possible |
| Energy-save mode/ Water temp. setting C1 *3 | 22 | 60 | °C | 0.1°C | 25 | 70 | | |
| Energy-save mode/ Outside temp. setting C2 *3 | 23 | 0 | °C | 0.1°C | -20 | 50 | | |
| Energy-save mode/ Water temp. setting C3 *3 | 24 | 35 | °C | 0.1°C | 25 | 70 | | |
| Energy-save mode/ Outside temp. setting C4 *3 | 25 | 25 | °C | 0.1°C | -20 | 50 | | |

* The graph below shows the relationship between C1/C3 and C2/C4.

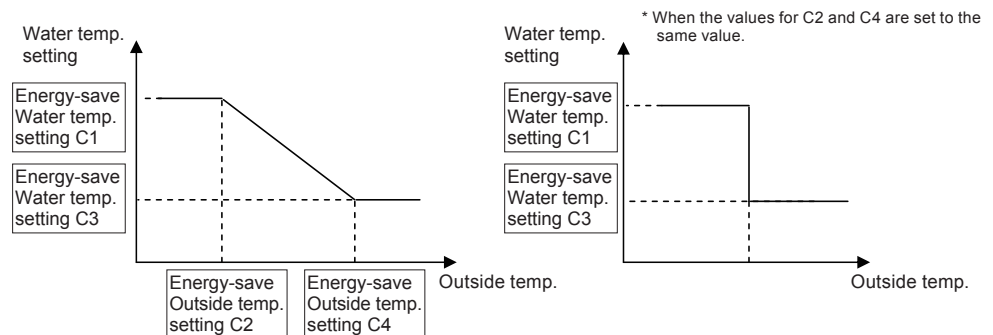

* When the values for C2 and C4 are set to the same value.

*1 These items need not be set when only a single water temperature setting is used.

When a signal through a dry contact is used to switch between the three modes, the water temperature setting is selected as follows.

*2 The setting ranges for the water temperature setting A, B, C1, and C3 are shown in the table below.

| Model | Water-temperature control | Lower limit | Upper limit |
|-----------------|--|-------------|-------------|
| CAHV-P500YA-HPB | Outlet-water-temperature-based control | 35.0°C | 70.0°C |
| | Inlet-water-temperature-based control | 32.0°C | 65.0°C |

* When the outside temperature is -5°C or below and the water temperature is set as follows, the unit may operate at a higher preset temperature than the preset temperature: Outlet temperature 45°C/Inlet temperature 40°C.

Step 4

Press the push switch SWP3 to save the change.

Press SWP3 once within one minute of changing the setting with SWP1 or SWP2 to save the setting.

Once the new setting is saved, the display will stop blinking and stay lit. The display will, then, return to the item code display mode.

If SWP3 is not pressed within one minute, the change will not be saved and the display will return to the item code display mode.

(2) Scheduled operation

Up to three sets of start/end times can be assigned for each day.

To operate the units according to the schedule, set the item code 5 to "1", and set the time for item codes 1 and 6 through 9.

Note The operation schedule function will operate only when SWS1 is set to "REMOTE."

Setting procedure

Step 0
Set the ON/OFF switch (SWS1) to OFF.

Set SWS1 to OFF from the remote controller or with the local switch. Settings cannot be changed unless the ON/OFF setting is set to OFF. *

* Settings can be changed from the optional remote controller regardless of the ON/OFF status of the operation switch.

Step 1
Set the dip switches SW02 and SW03.

Set the dip switches on the circuit board as follows before making the settings for the items described in this section.

| SW02 | SW03 | | | | | |
|------|------|-----|-----|-----|----|-----|
| -10 | 5 | 6 | 7 | 8 | 9 | 10 |
| OFF | OFF | OFF | OFF | OFF | ON | OFF |

Step 2
Select the desired item with the push switch SWP3.

Item codes 1, 5 through 9, 18, and 19 relate to scheduled operation setting. Set the item code to 1, and set the time for each of the relevant items. Press the push switch SWP3 to select an item code. Use the push switches SWP1 and SWP2 to change the value of the selected item. The value will keep blinking while it is being changed.

Step 3
Press the push switches SWP1 (↑) or SWP2 (↓) to increase or decrease the value.

Settings table

| Settable item | Item code | Initial value | Unit | Limits and increments | | |
|--|-----------|---------------|--------------------------|-----------------------|-------------|-------------|
| | | | | Increments | Lower limit | Upper limit |
| Current time | 1 | 0000 | Hour: minute | 1 minute | 0000 | 2359 |
| Enable or disable scheduled operation (ON/OFF) | 5 | 0 | Enable : 1 Disable: 0 | 1 | 0 | 1 |
| Operation start time 1 | 6 | 0000 | Hour: minute | 1 minute | 0000 | 2359 |
| Operation end time 1 | 7 | 0000 | Hour: minute | 1 minute | 0000 | 2359 |
| Operation start time 2 | 8 | 0000 | Hour: minute | 1 minute | 0000 | 2359 |
| Operation end time 2 | 9 | 0000 | Hour: minute | 1 minute | 0000 | 2359 |
| Operation start time 3 | 18 | 0000 | Hour: minute | 1 minute | 0000 | 2359 |
| Operation end time 3 | 19 | 0000 | Hour: minute | 1 minute | 0000 | 2359 |

Step 4
Press the push switch SWP3 to save the change.

Press SWP3 once within one minute of changing the setting with SWP1 or SWP2 to save the setting. Once the new setting is saved, the display will stop blinking and stay lit. The display will, then, return to the item code display mode. If SWP3 is not pressed within one minute, the change will not be saved and the display will return to the item code display mode.

Note A mode (preset temperatures) can be selected for each operation time period. See the next page for how to make the settings.

Note If Code 5 is set to "1," lock the remote controller's schedule function. See P.57 [4] - 3 - (2)

[When the peration Start/End times do not overlap]

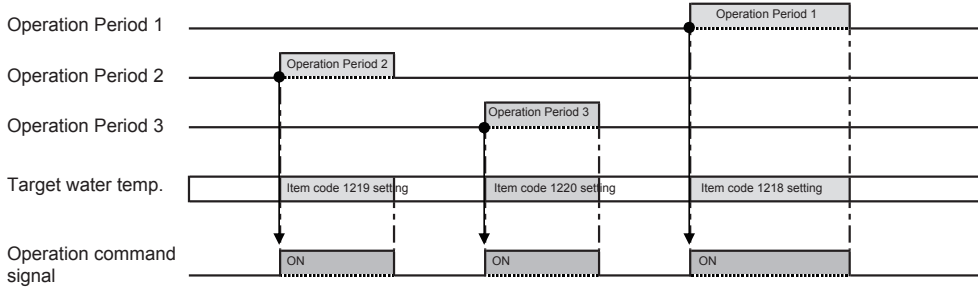

If "Start time 1 - End time 1", "Start time 2 - End time 2", "Start time 3 - End time 3" overlap, the settings for the period with a larger number will be ineffective.

[When operation period 1 and 2 overlap]

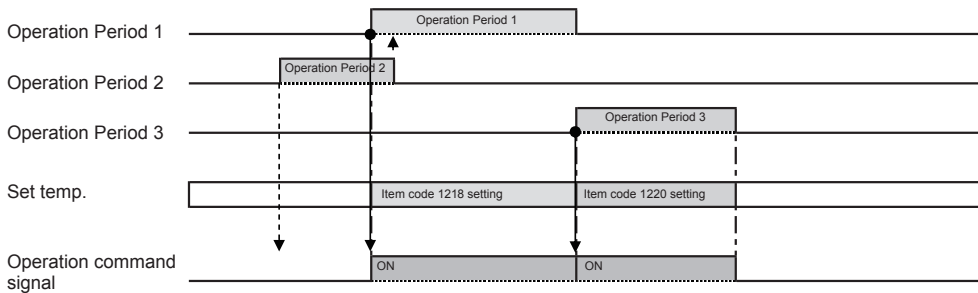

If two or more operation periods overlap, the settings for the period with a larger number will be ineffective. If Start time 1 and start time 3 are set to the same value, the setting for Start time 3 will be ineffective.

Set the setting for Start time 3 to a time at least one minute after End time 1.

(Once the compressor stops when End time 1 comes, the 3-minute restart delay function will keep the compressor from restarting for three minutes. Because of this, even if Start 3 time is set to a time within three minutes after End time 1, the compressor will not start right away.)

[When operation periods 1 and 3 overlap]

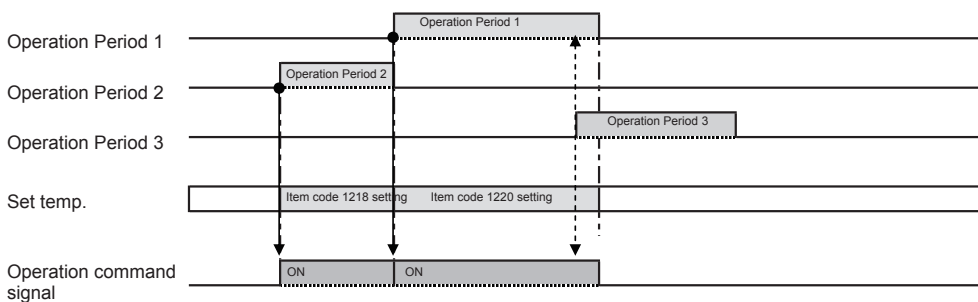

[When operation periods 2 and 3 overlap]

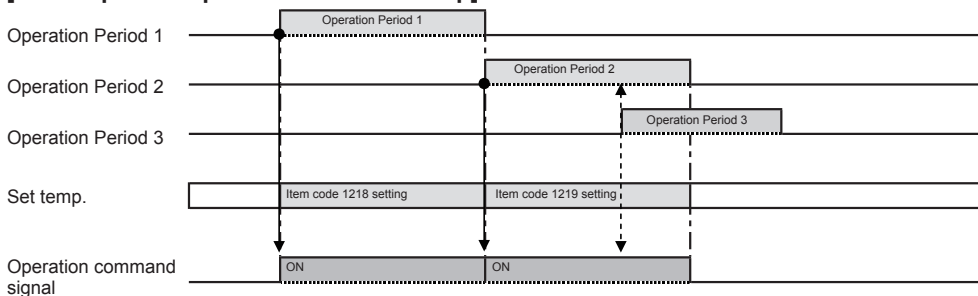

[When operation periods 1, 2, and 3 overlap]

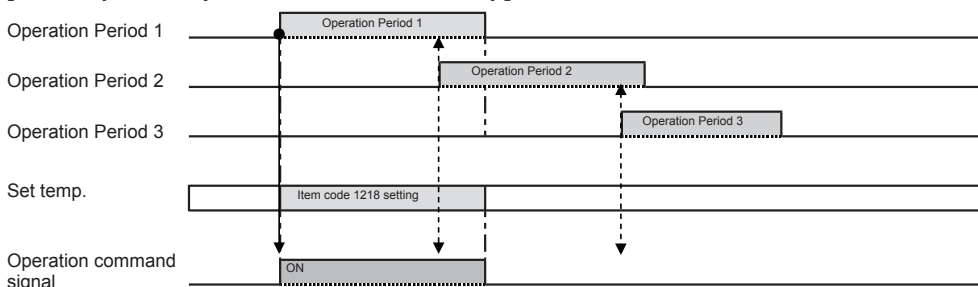

(*) Refer to the section on how to select the preset water temperatures on the next page.

(3) Selecting the preset temperature for different operation periods

Setting procedure

Step 0
Set the ON/OFF switch (SWS1) to OFF.

Set SWS1 to OFF from the remote controller or with the local switch. Settings cannot be changed unless the ON/OFF setting is set to OFF. *

* Settings can be changed from the optional remote controller regardless of the ON/OFF status of the operation switch.

Step 1
Set the dip switches SW02 and SW03.

Set the dip switches on the circuit board as follows before making the settings for the items described in this section.

| | | | | | | |
|------|------|-----|-----|----|-----|-----|
| SW02 | SW03 | | | | | |
| -10 | 5 | 6 | 7 | 8 | 9 | 10 |
| OFF | OFF | OFF | OFF | ON | OFF | OFF |

Step 2
Select the desired item with the push switch SWP3.

Item codes 1215 through 1220 relate to scheduled operation setting. Set the item code to 1, and set the time for each of the relevant items. Press the push switch SWP3 to select an item code. Use the push switches SWP1 and SWP2 to change the value of the selected item. The value will keep blinking while it is being changed.

Step 3
Press the push switches SWP1 (↑) or SWP2 (↓) to increase or decrease the value.

Settings table

| Items that can be set | Item code | Initial value | Unit | Setting | | | Note | Setting change from an optional remote controller |
|---|-----------|---------------|------|------------|-------------|-------------|------|---|
| | | | | Increments | Lower limit | Upper limit | | |
| Preset temp. 1 (Heating) | 1215 | 14 | TH | 1 | 14 | 15 | | Not possible |
| Preset temp. 1 (Hot Water) | 1216 | 14 | TH | 1 | 14 | 15 | | Not possible |
| Preset temp. 1 (Heating ECO) | 1217 | 14 | TH | 1 | 14 | 15 | | Not possible |
| Start/End time setting 1 (ON/OFF) water temp. setting | 1218 | 1 | | 1 | 1 | 3 | * | Not possible |
| Start/End time setting 2 (ON/OFF) water temp. setting | 1219 | 1 | | 1 | 1 | 3 | * | Not possible |
| Start/End time setting 3 (ON/OFF) water temp. setting | 1220 | 1 | | 1 | 1 | 3 | * | Not possible |

* 1: Preset temp. A (Heating)
2: Preset temp. B (Hot Water)
3: Preset temp. C (Heating ECO)

Step 4
Press the push switch SWP3 to save the change.

Press SWP3 once within one minute of changing the setting with SWP1 or SWP2 to save the setting. Once the new setting is saved, the display will stop blinking and stay lit. The display will, then, return to the item code display mode. If SWP3 is not pressed within one minute, the change will not be saved and the display will return to the item code display mode.

Selecting the preset temperature for different operation periods

When operating the units on schedule, preset temperatures can be selected from A, B, or C for time periods 1 through 3.

- Item code 1218: Operation time setting 1
 - Item code 1219: Operation time setting 2
 - Item code 1220: Operation time setting 3
- Item code 1215: Preset temp. 1 (Item code 11: Heating)
 - Item code 1216: Preset temp 2 (Item code 13: Hot Water)
 - Item code 1217: Preset temp 3 (Item code: 22- 25: Heating ECO)

Preset temperature selection for different time periods

| | | | Example 1 | Example 2 | Example 3 |
|------------|----------------------------|---|-------------|-----------|-------------|
| <1> <2> | Start time 1 End time 1 | Operation 1 (Preset temperature is selectable from A, B, or C.) | Heating | Heating | Hot Water |
| <3> <4> | Start time 2 End time 2 | Operation 2 (Preset temperature is selectable from A, B, or C.) | Hot Water | Hot Water | Heating ECO |
| <5> <6> | Start time 3 End time 3 | Operation 2 (Preset temperature is selectable from A, B, or C.) | Heating ECO | Heating | Hot Water |

Example 1

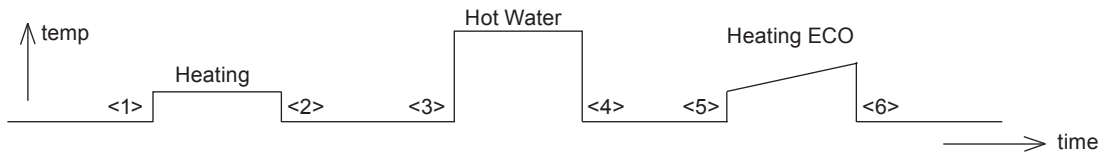

Example 2

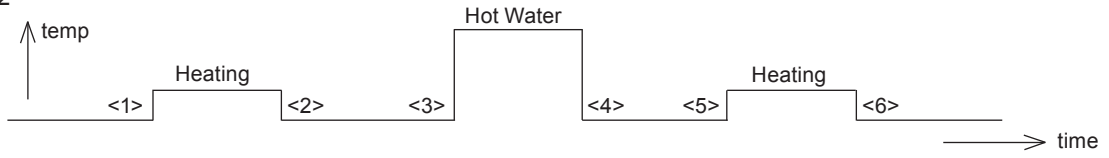

Example 3

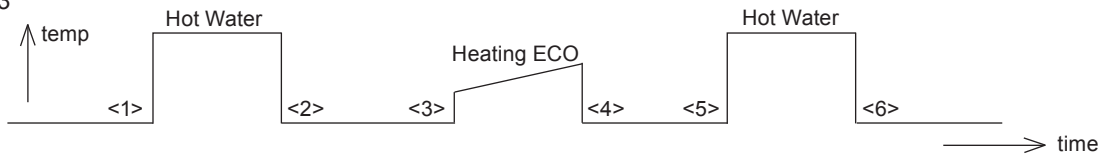

(4) Peak-demand control operation

Peak-demand control is a function used to control the power consumptions of the units during peak-demand hours.

* The type of peak-demand control signal to be used must be specified by the switch setting as explained on page 27.

Note When the peak-demand control signal is received via the remote controller, do not unnecessarily press the "DEMAND ON/OFF" button on the remote controller.

The number of units in operation and the compressor's maximum operating frequency will be controlled according to the peak-demand control signal.

| Individual and simultaneous unit control | Simplified multi-unit control |
|---|--|
| Individual unit control Maximum frequency = Maximum capacity under peak-demand control | Depending on the peak-demand control setting that is made on the main unit, the number of units in operation and the maximum operating frequency of the units in operation will be adjusted. |

Setting procedures

Set the maximum capacity setting on the circuit board.

Step 0
Set the ON/OFF switch (SWS1) to OFF.

Set SWS1 to OFF from the remote controller or with the local switch.
Settings cannot be changed unless the ON/OFF setting is set to OFF. *

* Settings can be changed from the optional remote controller regardless of the ON/OFF status of the operation switch.

Step 1
Set the dip switches SW2 and SW3.

Set the dip switches on the circuit board as follows before making the settings for the items described in this section.

| SW02 | SW03 | | | | | |
|------|------|-----|-----|-----|----|-----|
| -10 | 5 | 6 | 7 | 8 | 9 | 10 |
| OFF | OFF | OFF | OFF | OFF | ON | OFF |

Step 2
Select the desired item with the push switch SWP3.

Press the push switch SWP3 to select item code 2.
Press the push switches SWP1 or SWP2 to change the value of the selected item.
The value will keep blinking while it is being changed.

Step 3
Press the push switches SWP1 (↑) or SWP2 (↓) to increase or decrease the value.

Settings table

| Items that can be set | Item code | Initial value | Unit | Setting | | | Setting change from an optional remote controller |
|--------------------------------|-----------|---------------|--------------|------------|-------------|-------------|---|
| | | | | Increments | Lower limit | Upper limit | |
| Maximum capacity setting | 2 | 100 | % | 5% | 0 | 100 | Possible |
| Peak-demand control start time | 3 | 1300 | Hour: minute | 1 | 0000 | 2359 | Not possible |
| Peak-demand control end time | 4 | 1300 | Hour: minute | 1 | 0000 | 2359 | Not possible |

Step 4
Press the push switch SWP3 to save the change.

Press SWP3 once within one minute of changing the setting with SWP1 or SWP2 to save the setting.
Once the new setting is saved, the display will stop blinking and stay lit. The display will, then, return to the item code display mode.
If SWP3 is not pressed within one minute, the change will not be saved and the display will return to the item code display mode.
(*) If the peak-demand control contact is ON, units will operate at the maximum capacity that was set in the steps above.

(5) Setting the total number of units for a multiple system

Step 0
Set the ON/OFF switch (SWS1) to OFF.

Set SWS1 to OFF from the remote controller or with the local switch. Settings cannot be changed unless the ON/OFF switch is set to OFF.

Step 1
Set the dip switches SW2 and SW3.

Set the dip switches on the circuit board as follows to select how external inputs are received.

| SW2 | SW3 | | | | | |
|-----|-----|-----|-----|----|----|----|
| -10 | 5 | 6 | 7 | 8 | 9 | 10 |
| OFF | OFF | OFF | OFF | ON | ON | ON |

Step 2
Select the desired item with the push switch SWP3.

The item codes shown in the table below will appear in order every time the push switch SWP3 is pressed. Use the push switches SWP1 and SWP2 to change the value of the selected item. The value will keep blinking while it is being changed.

Step 3
Press the push switches SWP1 (↑) or SWP2 (↓) to increase or decrease the value.

Setting the total number of units

| | Item code | Increments | Lower limit | Upper limit | Initial value |
|---------------------------------------|-----------|------------|-------------|-------------|---------------|
| Total number of units in the system*1 | 107 | 1 | 1 | 16 | 1 |

*1 Enter the total number of units including the main unit. Applicable only to the main unit.

Step 4
Press the push switch SWP3 to save the change.

Press SWP3 once within one minute of changing the setting with SWP1 or SWP2 to save the setting. Once the new setting is saved, the display will stop blinking and stay lit. The display will, then, return to the item code display mode. If SWP3 is not pressed within one minute, the change will not be saved and the display will return to the item code display mode.

Step 5
Turn the power back on. Reset the system.

After changing the settings, reset the system according to the procedures detailed on page 21.

Note The new setting will not be saved unless a reset is performed.

Setting the unit addresses

Refer to section (4) System Configuration Procedures.

(6) Selecting the item that normally appears on the LED

| SW2 | SW3 | | | | | | Display content |
|-----|-----|-----|-----|-----|-----|-----|--|
| | -10 | 5 | 6 | 7 | 8 | 9 | |
| OFF | OFF | OFF | ON | OFF | OFF | OFF | Displays the operation mode.(*1) |
| OFF | OFF | ON | ON | OFF | OFF | OFF | Displays the operation mode.(*2) |
| OFF | ON | ON | OFF | OFF | OFF | OFF | Displays the current water temperature. |
| OFF | ON | OFF | OFF | OFF | OFF | OFF | Displays the water-temperature setting. |
| OFF | OFF | OFF | OFF | OFF | OFF | OFF | Displays the high and low refrigerant pressures. |

(*1)

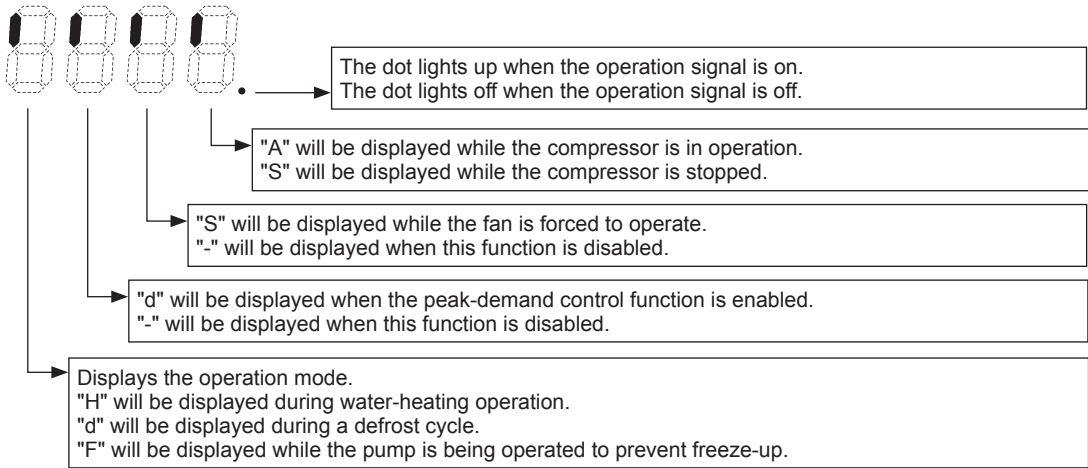

(*2)

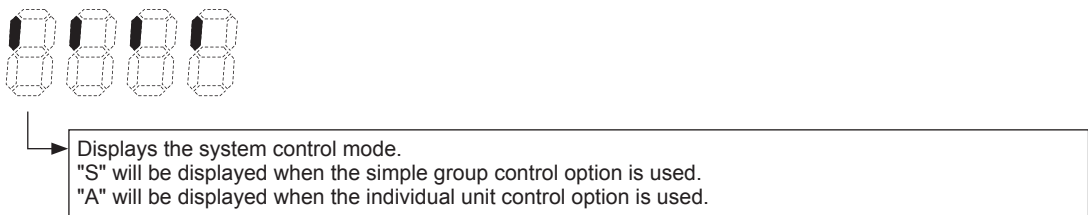

(7) Remote water temperature setting input signal type

By setting SW2-7 to ON, external analog signals can be used to set the water temperatures.

Analog input type can be selected from the following four types:

- "0": 4-20 mA
- "1": 0-10 V
- "2": 0-5 V
- "3": 2-10 V

Select item code 21 to set the type of analog input signal to be used to set the water temperature from a remote location.

Setting procedures

Set the dip switches on the circuit board as follows to change the settings.

Step 1
Set dip switches SW2, SW3, SW421-1, and SW421-2.

| | SW421-1 | SW421-2 |
|---------|---------|---------|
| 4-20 mA | ON | ON |
| 0-10 V | OFF | OFF |
| 1-5 V | OFF | ON |
| 2-10 V | OFF | OFF |

| | SW2 | | SW3 | | | | | |
|-----------------|-----|-----|-----|-----|-----|----|-----|--|
| | -10 | 5 | 6 | 7 | 8 | 9 | 10 | |
| Switch settings | OFF | OFF | OFF | OFF | OFF | ON | OFF | |

Step 2
Select the item to be set with push switch SWP3.

Select the type of analog input signal to be used to set the water temperature from a remote location.

Step 3
Change the values with push switches SWP1 (↑) or SWP2 (↓).

Press push switch SWP3 to select the item code.
Change the values with push switches SWP1 and SWP2.
Until the changed values are saved, the values will blink.

| Items that can be set | Item code | Initial value | Unit | Setting | | | Note | Setting change from an optional remote controller |
|---|-----------|---------------|------|------------|-------------|-------------|------|---|
| | | | | Increments | Lower limit | Upper limit | | |
| Water temperature setting input signal type | 21 | 0 | | 1 | 0 | 3 | | Not possible |

Step 4
Press push switch SWP3 to save the changed value.

Press SWP3 once within one minute of changing the settings to save the change.
When the new setting is saved, it will stop blinking, and the display will return to the item code display.
If the new setting is not save within one minute, the change will not be reflected, and the display will return to the item code display.

(8) Setting the water temperature using analog signal input

• When dip switch SW2-7 is set to ON (Enable external input), the target water temperature varies with the preset temperatures A and B and the type of analog input signal.

• When the water temperature setting input signal type is set to 0 (4-20 mA)

- External analog input signal of 4 mA: Preset temp. A
- External analog input signal of 20 mA: Preset temp. B
- External analog input signal of between 4 and 20 mA: the preset temperature will be linearly interpolated.

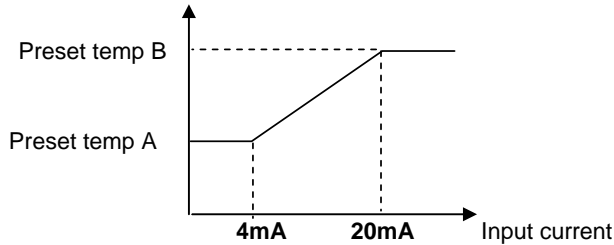

• When the water temperature setting input signal type is set to 1 (0-10 V)

- External analog input signal of 0 V: Preset temp. A
- External analog input signal of 10 V: Preset temp. B
- External analog input signal of between 0 and 10 V: the preset temperature will be linearly interpolated.

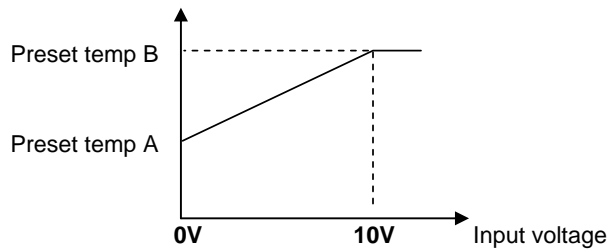

• When the water temperature setting input signal type is set to 2 (1-5 V)

- External analog input signal of 1 V: Preset temp. A
- External analog input signal of 5 V: Preset temp. B
- External analog input signal of between 1 and 5 V: the preset temperature will be linearly interpolated.

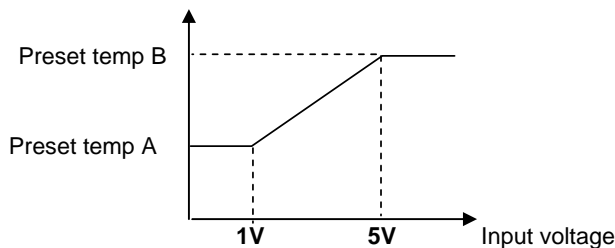

• When the water temperature setting input signal type is set to 3 (2-10 V)

- External analog input signal of 2 V: Preset temp. A
- External analog input signal of 10 V: Preset temp. B
- External analog input signal of between 2 and 10 V: the preset temperature will be linearly interpolated.

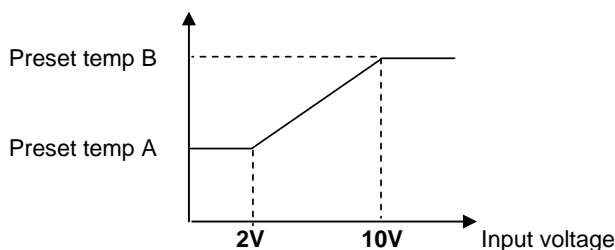

(9) Setting the booster heater operation conditions

A temperature at which the booster heater will go into operation (TWL) can be selected.

Select item code 1052 to set the threshold temperature (TWL) for booster heater operation.

Booster heater operation conditions

•Individual system

The operation command signal is ON and at least one of the following four conditions is met.

- 1 Both the MAIN and SUB circuits are sending the abnormal signal stop signals, or the local switch of the SUB circuit is turned off.
- 2 The unit has been forced to stop due to abnormal outside temperature.
- 3 Water-temperature control option is set to OFF, and the water inlet temperature (*) drops below TWL..
- 4 Water-temperature control option is set to ON, and the representative water temperature drops below TWL.

The booster heater signal of the MAIN circuit comes on.

•Multiple system

The operation command signal is ON and at least one of the following three conditions is met.

- 1 Both circuits of all units are sending the abnormal stop signal, or the local switches of all circuits on all units except the MAIN circuit to which the representative temperature sensor is connected are turned off.
- 2 The MAIN circuit of the main unit has been forced to stop due to abnormal outside temperature.
- 3 Representative water temperatures (TH14 and TH15) drop below TWL

The booster heater signal of the MAIN circuit comes on.

Booster heater operation-stop conditions

The operation command signal is OFF or all of the following three conditions are met.

- 1 None of the circuit is sending the abnormal stop signal, or the local switch of any of the circuit is not turned off.
- 2 The MAIN circuit of the main unit has not been forced to stop due to abnormal outside temperature.
- 3 One of the following conditions is met:
 - a. Water-temperature control option is set to OFF, and the water inlet temperature (*) exceeds TWL+2°C.
 - b. Water-temperature control option is set to ON, and the representative temperatures (TH14 and TH15) exceed TWL+2°C.

(*) Unit's inlet water temperature: Average value between the water temperature settings of the MAIN and SUB circuits

Setting procedures

Set the dip switches on the circuit board as follows to change the settings.

Step 1
Set dip switches SW2 and SW3.

| | | | | | | | |
|-----------------|-----|-----|-----|-----|-----|----|-----|
| | SW2 | SW3 | | | | | |
| | -10 | 5 | 6 | 7 | 8 | 9 | 10 |
| Switch settings | OFF | OFF | OFF | OFF | OFF | ON | OFF |

Step 2
Select the item to be set with push switch SWP3.

Step 3
Change the values with push switches SWP1 (↑) or SWP2 (↓).

Select item code 1052 to set the operation temperature (TWL) for the booster heater.

Press push switch SWP3 to select the item code.

Change the values with push switches SWP1 and SWP2.

Until the changed values are saved, the values will blink.

| Items that can be set | Item code | Initial value | Unit | Setting | | | Note | Setting change from an optional remote controller |
|--|-----------|---------------|------|------------|-------------|-------------|------|---|
| | | | | Increments | Lower limit | Upper limit | | |
| Booster heater operation temperature (TWL) | 1052 | 10 | °C | 0.1 | 0 | 70 | | Not possible |

Press and hold push switches SWP1 and SWP2 to fast forward the numbers.

Step 4
Press push switch SWP3 to save the changed value.

Press SWP3 once within one minute of changing the settings to save the change.

When the new setting is saved, it will stop blinking, and the display will return to the item code display.

If the new setting is not save within one minute, the change will not be reflected, and the display will return to the item code display.

5. Electrical Wiring Installation

[1] Wiring of main power supply and equipment capacity

Schematic Drawing of Wiring (Example)

- Ⓐ: Switch (Breakers for wiring and current leakage)
- Ⓑ: Breakers for current leakage
- Ⓒ: Outdoor unit
- Ⓓ: Pull box
- Ⓔ: Indoor unit

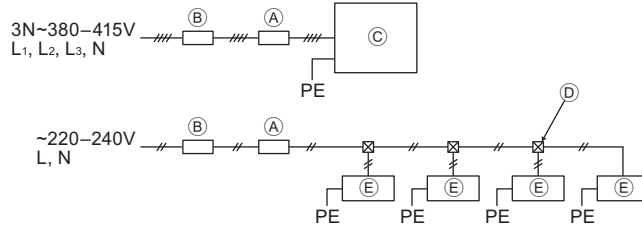

Thickness of wire for main power supply, capacities of the switch and system impedance

| Model | Minimum wire thickness (mm ²) | | | Breaker for current leakage | Local switch (A) | | Breaker for wiring (NFB) (A) | Max. Permissible System Impedance |
|-----------------|---|--------|--------|-----------------------------|------------------|------|------------------------------|-----------------------------------|
| | Main cable | Branch | Ground | | Capacity | Fuse | | |
| CAHV-P500YA-HPB | 25 | - | 25 | 75A 100mA 0.1sec. or less | 75 | 75 | 75 | 0.28 Ω |

1. Use dedicated power supplies for the unit. Ensure each units are wired individually.
2. Bear in mind ambient conditions (ambient temperature, direct sunlight, rain water, etc.) when proceeding with the wiring and connections.
3. The wire size is the minimum value for metal conduit wiring. If the voltage drops, use a wire that is one rank thicker in diameter.
Make sure the power-supply voltage does not drop more than 10%.
4. Specific wiring requirements should adhere to the wiring regulations of the region.
5. Power supply cords of parts of appliances for outdoor use shall not be lighter than polychloroprene sheathed flexible cord (design 60245 IEC57).
6. A switch with at least 3 mm contact separation in each pole shall be provided by the Air Conditioner installer.
7. Do not install a phase advancing capacitor on the motor. Doing so may damage the capacitor and result in fire. The figure in the parentheses indicates the capacity necessary when the "Maximum capacity operation" setting is selected.

⚠ Warning:

- Be sure to use specified wires for connections and ensure no external force is imparted to terminal connections. If connections are not fixed firmly, heating or fire may result.
- Be sure to use the appropriate type of overcurrent protection switch. Note that generated overcurrent may include some amount of direct current.

⚠ Caution:

- Some installation sites may require attachment of an earth leakage breaker for the inverter. If no earth leakage breaker is installed, there is a danger of electric shock.
- Do not use anything other than a breaker and fuse with the correct capacity. Using a fuse or wire of too large capacity may cause malfunction or fire.

Note:

- This device is intended for the connection to a power supply system with a maximum permissible system impedance shown in the above table at the interface point (power service box) of the user's supply.
- The user must ensure that this device is connected only to a power supply system which fulfils the requirement above.
If necessary, the user can ask the public power supply company for the system impedance at the interface point.
- This equipment complies with IEC 61000-3-12 provided that the short-circuit power SSC is greater than or equal to SSC (*2) at the interface point between the user's supply and the public system. It is the responsibility of the installer or user of the equipment to ensure, by consultation with the distribution network operator if necessary, that the equipment is connected only to a supply with a short-circuit power SSC greater than or equal to SSC (*2).

S_{sc} (*2)

| Model | S _{sc} (MVA) |
|-----------------|-----------------------|
| CAHV-P500YA-HPB | 4.11 |

Types of control cables

| | | | |
|----------------------|------------------------------|-------------------------|---|
| Control cable wiring | Remote controller cable | Size | 0.3 - 1.25 mm ² (Max. 200 m total) |
| | | Recommended cable types | CVV |
| | M-NET cable between units *1 | Size | More than 1.25 mm ² (Max. 120 m total) |
| | | Recommended cable types | Shielding wire CVVS, CPEVS or MVVS |
| | External input wire size | | Min. 0.3 mm ² |
| | External output wire size | | 1.25 mm ² |

*1. Use a CVVS or CPEVS cable (Max. total length of 200 m) if there is a source of electrical interference near by (e.g., factory) or the total length of control wiring exceeds 120 m.

[2] Cable connections

<1> Terminal Block Arrangement

To remove the front panel of the control box, unscrew the four screws and pull the panel forward and then down.

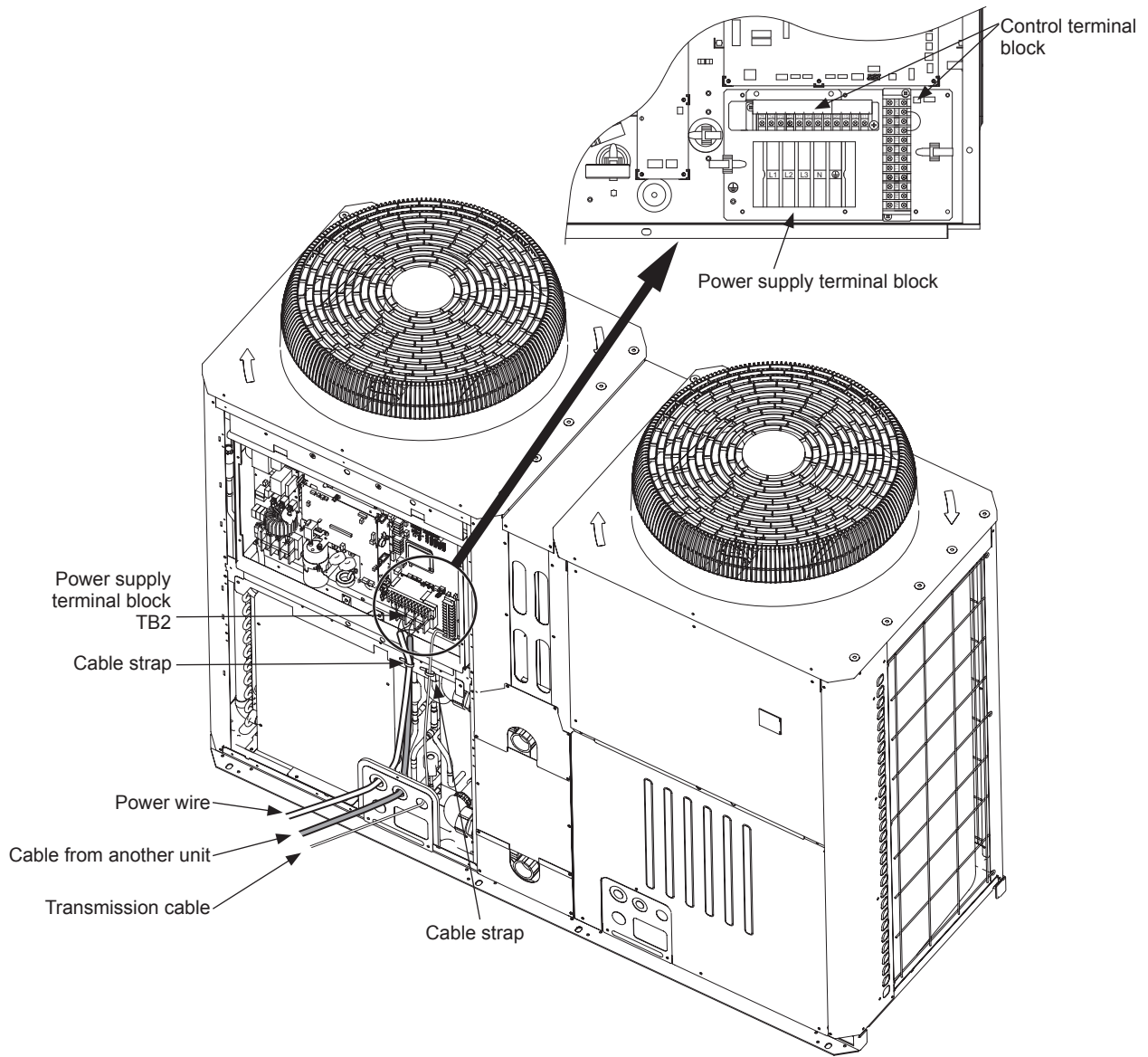

Important: Power supply cables larger than 60 mm² in diameter are not connectable to the power supply terminal block (TB2). Use a pull box to connect them.

<2> Installing the conduit tube

- Punch out the knockout hole for wire routing at the bottom of the front panel with a hammer.
- When putting wires through knockout holes without protecting them with a conduit tube, deburr the holes and protect the wires with protective tape.
- If damage from animals is a concern, use a conduit tube to narrow the opening.

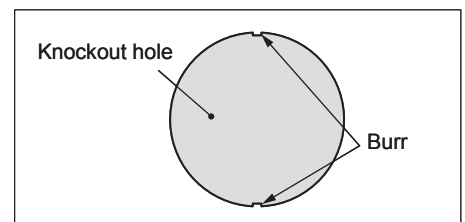

CAHV-P500YA-HPB ELECTRICAL WIRING DIAGRAM

- Note 1. Single-dotted lines indicate field wiring.
- Note 2. Fan terminals have a locking function. Press the tab in the middle.
- Note 3. The symbols of the field connecting terminals are as follows.
- Note 4. When switching the capacity setting, remove the short-circuit wire on terminal 23 and 25.
- Note 5. The broken lines indicate the optional parts, field-supplied parts, and add work.
- Note 6. Make sure to connect a pump inductance contact.
- Note 7. One of the following methods can be selected individually for how to input operation signal: to input from the optional remote control or by setting time ranges.

- Note 8. Leave a space of at least 5 cm between the low voltage external wiring (no-voltage contact input and remote controller wiring) and wiring of 100 V or greater. Do not place them in the same conduit.
- Note 9. Use a contact that takes 12 VDC 5 mA for no-voltage contact input.
- Note 10. When a capacity cable is used for the control cable wiring, use a separate capacity cable for the following wiring.
Using the same capacity cable may cause malfunctions and damage.
- Note 11. The SW1 - SW3 switches indicated with can be set on site. Do not change the other SW1 - SW3 switch settings.

Symbol Explanation

| Symbol | Explanation |
|--------|--|
| CH | Compressor heater (for heating the compressor) |
| CT1.2 | AC current sensor |
| CT3 | Capacitor (Electrolysis) |
| GL00 | DC reactor |
| F01 | Fuse |
| F02 | Electronic expansion valve (Main circuit) |
| F03 | Electronic expansion valve (Injection) |
| F04 | Fan motor |
| F05 | Compressor motor |
| F06 | Electrical resistance |
| LE1 | Solenoid valve (Injection circuit) |
| LE2 | Solenoid valve (Main gas circuit) |
| LE3 | Function setting connector |
| Z1S4 | 4-way valve |
| 63HS | High pressure sensor |
| 63HI | High pressure switch |
| 63LS | Low pressure sensor |
| 72C | Electromagnetic relay (Inverter main circuit) |
| TH1~4 | Thermistor |
| TH4 | Earth leakage breaker |
| (F2) | Fuse |
| (L2) | Emergency signal (for extra heater) |
| (L3) | Power motor |
| (MP) | Overcurrent relay (A/PM) |
| (G1P) | Overcurrent relay (A/PM) |
| (G2P) | Electromagnetic connector (Pump) |

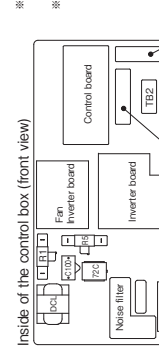
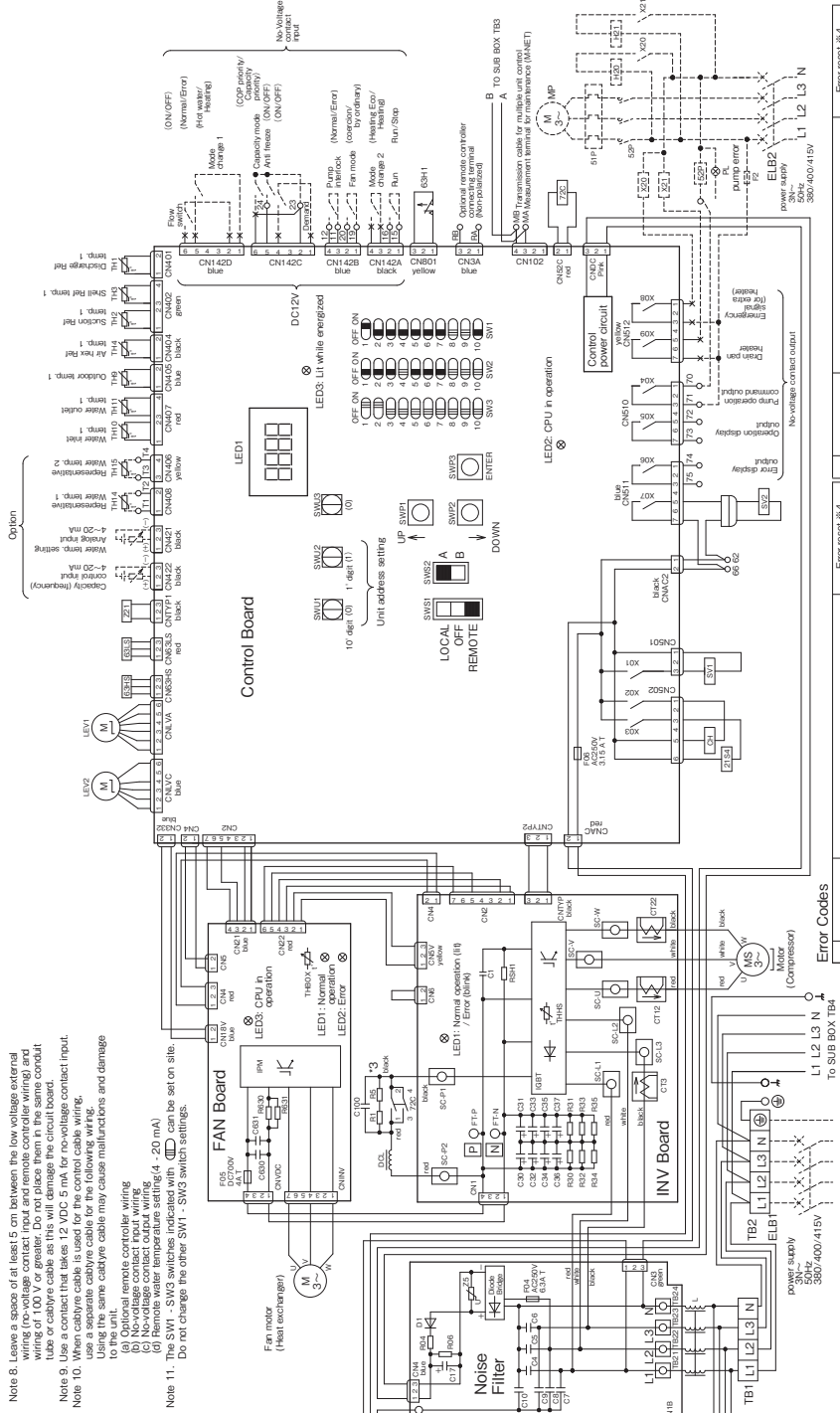

- ### Inside of the control box (front view)
- Control board SW setting:
 - SW3-5: ON
 - SW3-6: OFF
 - SW3-7: ON
 - SW3-8: OFF
 - SW3-9: OFF
 - SW3-10: OFF
 - SW3-11: OFF
 - SW3-12: OFF
 - Select a display by setting the switches.
 - The current water temperature is displayed according to the preset water temperature method.

- ### Display setting
- Control board display
 - Present water temperature
 - Current water temperature
 - High pressure/Low pressure
- Note 1. If an error occurs, a 4-digit error code, as explained in the table on the right, will blink on the board and remote controller display. (Error code) and (Error source address) appear alternately on the remote controller display.
- Note 2. Errors that can be reset regardless of the switch settings
- Note 3. Errors that can be reset if the remote reset setting on the unit is set to 'Enable' (factory setting)
- Note 4. Errors that cannot be reset
- Note 5. Errors that will be automatically reset after the cause of the error is removed
- Note 6. Power failure is detected only when the switch setting 'Automatic recovery after power failure' on the unit is set to 'Disable'. (The default setting is 'Enable'.)
- Note 7. Depending on the system configuration, the unit may come to an abnormal stop when the communication error lasts for 10 minutes or longer. In this case, the error needs to be reset by setting either SW1 on the unit (PCB) or remote reset.
- Note 8. This error code will appear when multiple errors occur that are reset in different ways and when one or more of these errors have not been reset. This error can be reset by turning off and then back on the unit's power.
- Note 9. **Resistor operations without removing the cause may bias the heat exchanger.** Refer to the installation manual for detail codes.

Error Codes

| No. | Error code (PCB #5) | Error type | No. | Error code (PCB #5) | Error type |
|-----|---------------------|---|-----|---------------------|---|
| 1 | R00 | Lowest error | 28 | S108 | Archieval switch/valve error (HS SUB Circuit) |
| 2 | R01 | Power failure | 29 | S109 | Outside temperature sensor error (THB) |
| 3 | R02 | Discharge temperature fault | 30 | S110 | THHS sensor/Circuit fault |
| 4 | R03 | Compressor flooding | 31 | S111 | THL water temperature sensor error (THO MAIN Circuit) |
| 5 | R04 | Water supply cutoff (flow switch) | 32 | S112 | THH water temperature sensor error (THI MAIN Circuit) |
| 6 | R05 | Compressor fault | 33 | S113 | Outlet water temperature sensor error (THS SUB Circuit) |
| 7 | R06 | Open phase | 34 | S114 | Outlet water temperature sensor error (THS SUB Circuit) |
| 8 | R07 | Serial communication error | 35 | S115 | Representative water temperature sensor error (TH14, TH15) |
| 9 | R08 | Small temperature fault | 36 | S116 | High-pressure sensor fault |
| 10 | R09 | Heat exchanger freeze up | 37 | S117 | Low-pressure sensor fault |
| 11 | R10 | Heat exchanger freeze up | 38 | S118 | CCO/CCS sensor error (Circuit fault) |
| 12 | R12 | Over heat (T/phase) | 39 | S119 | Communication error between the MAIN and SUB units |
| 13 | R15 | Power supply frequency fault | 40 | S120 | Communication error between the MAIN and SUB units (Simple multiple unit control) |
| 14 | R16 | Active filter fault | 41 | S121 | Address overlap |
| 15 | R17 | Power supply frequency fault | 42 | S122 | Remote controller signal reception error 1 |
| 16 | R18 | Inverter overcurrent fault | 43 | S123 | Remote controller signal reception error 2 |
| 17 | R19 | Inverter overcurrent fault | 44 | S124 | Discrete address system error |
| 18 | R20 | Inverter overcurrent protection fault | 45 | S125 | Model setting error |
| 19 | R21 | PM error (circulator/concurrent relay trip) | 46 | S126 | Incompatible combination of units |
| 20 | R22 | PM error (circulator/concurrent relay trip) | 47 | S127 | Remote controller signal reception error 1 |
| 21 | R23 | Discharge temperature sensor error (TH1 MAIN Circuit) | 48 | S128 | Remote controller signal reception error 2 |
| 22 | R24 | Discharge temperature sensor error (TH2 MAIN Circuit) | 49 | S129 | Remote controller signal reception error 3 |
| 23 | R25 | Small temperature sensor error (TH3 MAIN Circuit) | 50 | S130 | Discrete address system error |
| 24 | R26 | Avch heat exchanger temperature sensor error (TH4 MAIN Circuit) | 51 | S131 | Model setting error |
| 25 | R27 | Discharge temperature sensor error (TH5 SUB Circuit) | 52 | S132 | Incompatible combination of units |
| 26 | R28 | Compressor heat temperature sensor error (TH6 SUB Circuit) | | | |
| 27 | R29 | Small temperature sensor error (TH7 SUB Circuit) | | | |

CAHV-P500YA-HPB ELECTRICAL WIRING DIAGRAM

- Note 1. Single-dotted lines indicate field wiring.
- Note 2. Fusion terminals have a locking function. Press the tab in the middle. Check that the terminals are securely locked in place after insertion.
- Note 3. The SW1 - SW3 switches indicated with can be set on site. Do not change the other SW1 - SW3 switch settings.

Symbol explanation

| Symbol | Explanation |
|---------|---|
| CH | Crankcase heater (for heating the compressor) |
| CT12 | AC current sensor |
| CT20 | Capacitor (Electrolytic) |
| DC1 | DC reactor |
| FD2 | Fuse |
| FD4 | Fuse |
| FD5 | Fuse |
| FD6 | Fuse |
| LEV1 | Electronic expansion valve (Main circuit) |
| LEV2 | Electronic expansion valve (Injection) |
| M | Fan motor |
| MS | Compressor motor |
| R1 | Electrical resistance |
| SV1 | Solenoid valve (Injection circuit) |
| THHS | IGBT temperature |
| Z1 | Function set/ID connector |
| Z1S4 | 4-way valve |
| 53HS | High pressure sensor |
| 53HT | High pressure switch |
| 53LS | Low pressure sensor |
| Z20 | Electromagnetic relay (Inverter main circuit) |
| TH2, 13 | Thermistor |

Inside of the control box (front view)

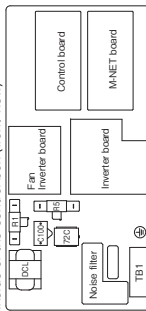

Display setting

| | |
|------------------------------|-----------------------------|
| Control board display | Control board SW setting #1 |
| Preset water temperature | SW3.5: ON - SW3.6: OFF |
| Current water temperature #2 | SW3.5: ON - SW3.6: ON |
| High pressure/Low pressure | SW2.10: OFF - SW3.8: OFF |
| | SW3.9: OFF - SW3.10: OFF |
| | SW3.7: OFF |

- #1. Select a display by setting the switches.
- #2. The current water temperature is displayed according to the preset water temperature method.

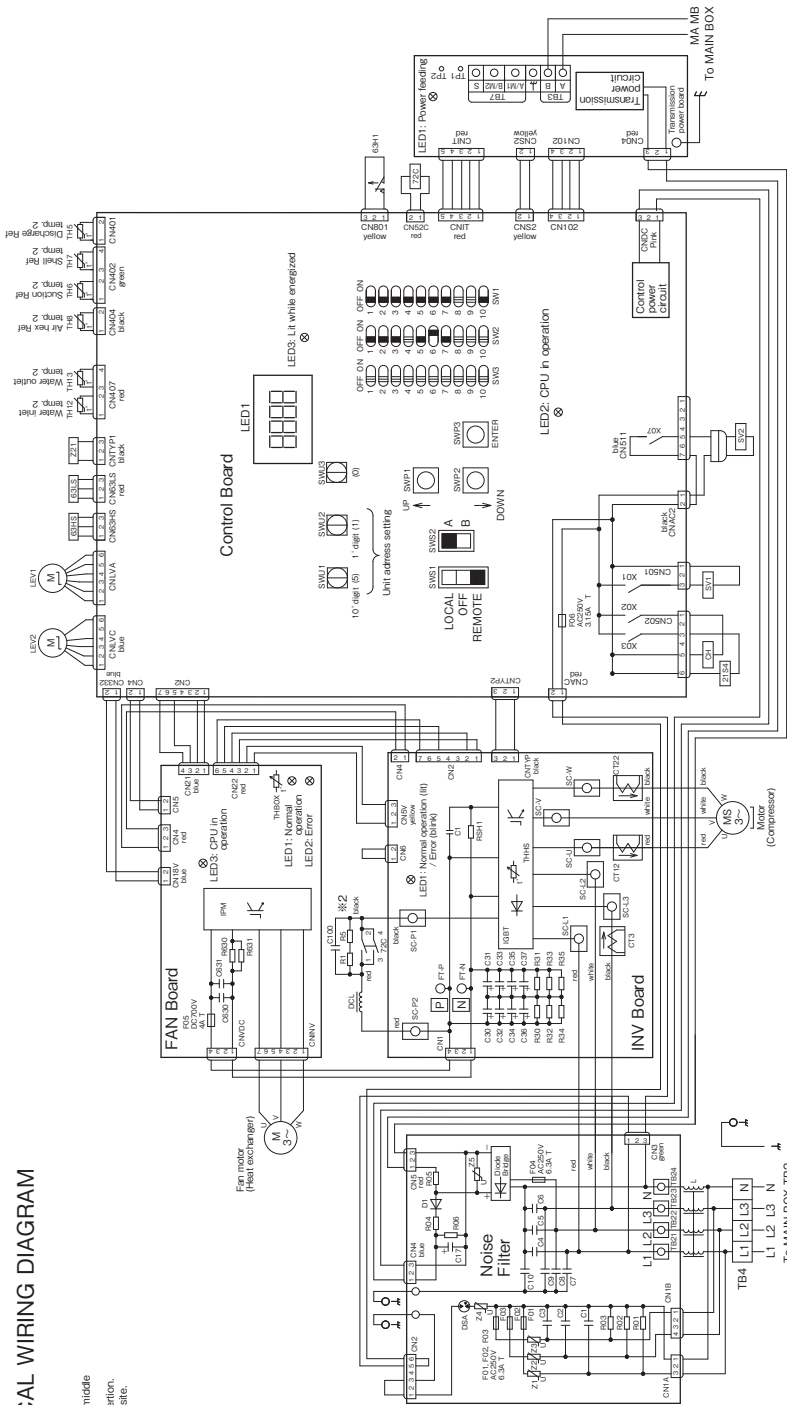

Error Codes

| No. | Error code (PCB #3) | Error type | Remote SW | Operation | Error reset #14 (PCB) |
|-----|---------------------|---|-----------|-----------|-----------------------|
| 1 | 6550 | Unreset errors | X | X | ○ |
| 2 | 6551 | Discharge temperature fault | 8:5 | ○ | ○ |
| 3 | 6554 | Compressor flooding | ○ | ○ | ○ |
| 4 | 6559 | Water supply cutoff (Flow switch) | ○ | ○ | ○ |
| 5 | 6561 | High pressure fault | ○ | ○ | ○ |
| 6 | 6563 | Shell communication error | X | ○ | ○ |
| 7 | 6564 | Shell temperature fault | ○ | ○ | ○ |
| 8 | 6565 | Heat exchanger/freeze up | ○ | ○ | ○ |
| 9 | 6566 | Vacuum protection fault | ○ | ○ | ○ |
| 10 | 6567 | Power supply frequency fault | ○ | ○ | ○ |
| 11 | 6568 | Power supply frequency fault | ○ | ○ | ○ |
| 12 | 6569 | Inverter fan voltage fault | ○ | ○ | ○ |
| 13 | 6570 | Inverter contact protection fault | ○ | ○ | ○ |
| 14 | 6571 | IPM error (inclusion)/overcurrent relay trip | ○ | ○ | ○ |
| 15 | 6572 | Cooling fan temperature | ○ | ○ | ○ |
| 16 | 6573 | Compressor inlet temperature thermistor error (TH1 MAIN Circuit) | ○ | ○ | ○ |
| 17 | 6574 | Compressor inlet temperature thermistor error (TH2 MAIN Circuit) | ○ | ○ | ○ |
| 18 | 6575 | Compressor inlet temperature thermistor error (TH3 MAIN Circuit) | ○ | ○ | ○ |
| 19 | 6576 | Compressor inlet temperature thermistor error (TH4 MAIN Circuit) | ○ | ○ | ○ |
| 20 | 6577 | Compressor inlet temperature thermistor error (TH5 MAIN Circuit) | ○ | ○ | ○ |
| 21 | 6578 | Compressor inlet temperature thermistor error (TH6 MAIN Circuit) | ○ | ○ | ○ |
| 22 | 6579 | Compressor inlet temperature thermistor error (TH7 MAIN Circuit) | ○ | ○ | ○ |
| 23 | 6580 | Compressor inlet temperature thermistor error (TH8 MAIN Circuit) | ○ | ○ | ○ |
| 24 | 6581 | Compressor inlet temperature thermistor error (TH9 MAIN Circuit) | ○ | ○ | ○ |
| 25 | 6582 | Compressor inlet temperature thermistor error (TH10 MAIN Circuit) | ○ | ○ | ○ |
| 26 | 6583 | Compressor inlet temperature thermistor error (TH11 MAIN Circuit) | ○ | ○ | ○ |
| 27 | 6584 | Compressor inlet temperature thermistor error (TH12 MAIN Circuit) | ○ | ○ | ○ |

- #3. If an error occurs, a 4-digit error code, as explained in the table on the right, will blink on the board and remote controller display. (Error code) and (Error source address) appear alternately on the remote controller display.
- #4. Errors that can be reset regardless of the switch settings:
 - ... Errors that can be reset if the remote reset setting on the unit is set to 'Enable' (factory setting).
 - ... Errors that cannot be reset.
 - ... Errors that will be automatically reset after the cause of the error is removed.
- #5. Power failure can be detected only when the switch setting 'Automatic recovery' is set to 'On'. If the power is restored, the unit will automatically resume operation. (Error code) and (Error source address) will blink on the remote controller display. (Error code) and (Error source address) will blink on the board and remote controller display. (Error code) and (Error source address) will blink on the remote controller display.
- #6. Depending on the system configuration, the unit may come to an abnormal stop when the communication error lasts for 10 minutes or longer. In this case, the error needs to be reset by setting either SW1 on the unit (PCB) or remote controller to 'Enable' (factory setting).
- #7. This error code will appear when multiple errors occur that are reset in different ways and when one or more of these errors have not been reset. This error can be reset by turning off and then back on the unit's power.
- #8. Remove the cause of the error before resetting the error.
- #9. Resuming operation without removing the cause may burn the heat exchanger. Refer to the Installation Manual for detail codes.

When using a local controller, refer to the table below for the types of input/output signals that are available and the operations that correspond to the signals.

External Input/Output

| Input | non-Voltage contact | | | | Terminal clock / connector | |
|--------|-------------------------------------|---|---|--|--|-----------|
| | Kind of non voltage contact | Close/Open | The operation in the condition when this contact is open | The operation in the condition when this contact is close | | |
| (a) | OPERATION | RUN/STOP | The unit runs under the temp which was setted by you | The unit stops except for Anti-freeze mode | TB6 15-16 | |
| (b) | MODE CHANGE 2 | Heating Eco/Heating | The unit runs under the temp A°C which was setted by you | The unit runs under the temp C°C which was setted by you | CN142A 3-4 | |
| (c) | CAPACITY MODE | COP Priority/ Capacity Priority | The unit runs in the maxmum capacity mode | The unit runs in the COP priority mode | CN142C 2-6 | |
| (d) | MODE CHANGE 1 | Hot water/Heating | The unit runs under the temp A°C which was setted by you | The unit runs under the temp B°C which was setted by you | CN142D 1-5 | |
| (e) | ANTI FREEESE | On/Off | The unit runs keeping outlet water temp 25°C-35°C even if (a) ON/OFF control is off by your operation | The unit runs keeping outlet water temp the temp setted by you if (a) ON/OFF control is on by your operation | TB6 23-24 | |
| (f) | FAN MODE | COERSION/ ORDINARY | Fan continuous run at comp stopping | Fan runs when compressor is stopping | TB5 19-20 | |
| (g) | FLOW SWITCH | Normal/Error | Compressor don't run | Compressor can run | CN142D 2-6 | |
| (h) | PUMP INTERLOCK | Normal/Error | Compressor don't run | Compressor can run | TB5 11-12 | |
| (i) | DEMAND | On/Off | The unit runs under the capacity(comp frequency) rate which was setted by you | The unit runs in the maximum capacity mode or the COP priority mode which you selected | CN142C 1-4 | |
| Analog | | | | | | |
| | Kind of input | Operation | | | | |
| (j) | Water Temp Setting | Setting temp changes automatically according to 4-20mA Analog input | | | CN421 2(+)-3(-) | |
| (k) | External Water Sensor (option) TH14 | - | | | TB6 T1-T2 | |
| (l) | External Water Sensor (option) TH15 | - | | | TB6 T3-T4 | |
| Output | Kind of contact | Voltage | When the signal is on? | When the signal is off? | | |
| | (m) | CHECK DISPLAY | non-Voltage | If the unit stops unusually this output is on | If the unit runs usually,this output is off | TB5 74-75 |
| | (n) | OPERATION DISPLAY | non-Voltage | If (a) ON/OFF control is on,this output is on | If (a) ON/OFF control is OFF this output is off | TB5 72-73 |
| | (o) | PUMP OPERATION COMMAND | non-Voltage | If (a) ON/OFF control is on,this output is on | If (a)ON/OFF control is OFF this output is off | TB5 70-71 |
| | (p) | EMERGENCY SIGNAL(option) | non-Voltage | If the unit stops or water temp below setting temp E °C | If the unit runs and water temp over setting temp F °C | CN512 1-3 |
| | (q) | DRINPAN HEATER SIGNAL (option) | non-Voltage | If outdoor temp below 1 °C | If outdoor temp over 3 °C | CN512 5-7 |
| Other | REMOTE CONTROLER | PARW21MAA | | | TB6 RA-RB | |
| | M-NET | - | | | TB6 MA-MB | |

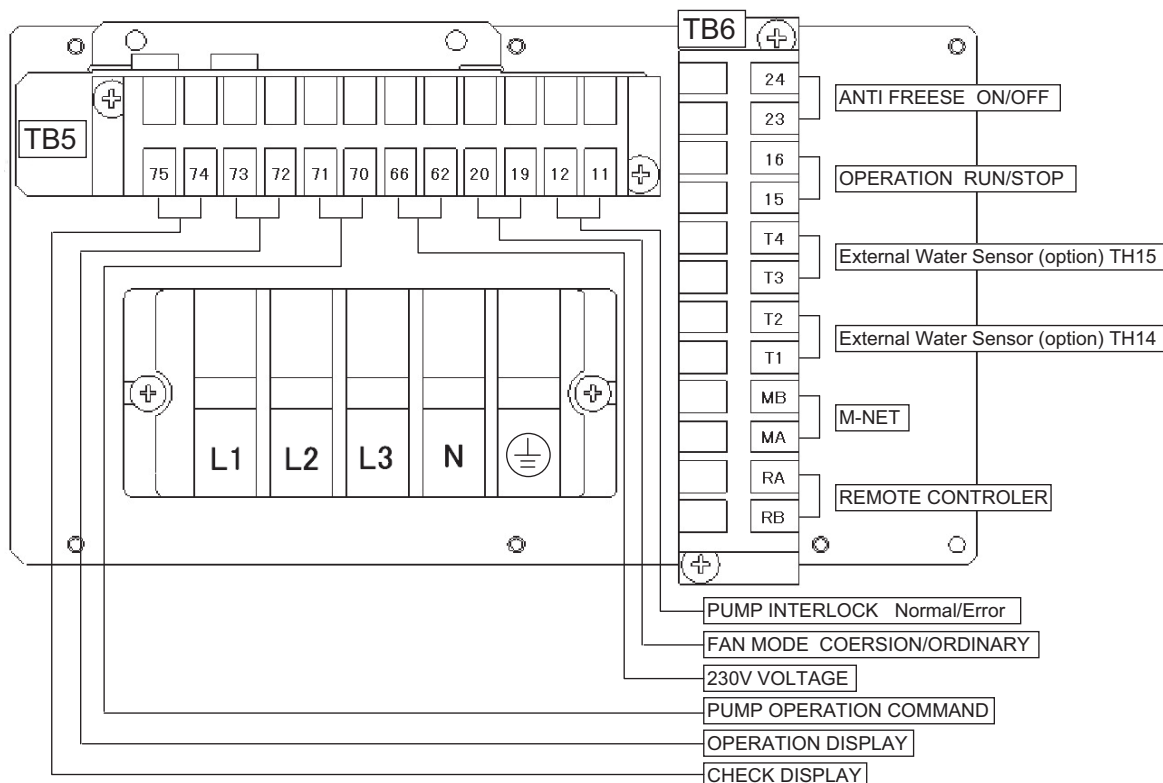

6. Troubleshooting

Troubleshooting must be performed only by personnel certified by Mitsubishi Electric.

[1] When No Error Codes Are Displayed

If a problem occurs, please check the following. If a protection device has tripped and brought the unit to stop (when an error code is blinking on the LED), resolve the cause of the error before resuming operation.

Resuming operation without removing the causes of an error may damage the unit and its components.

| Problem | Check item | Cause | Solution |
|---|--|--|---|
| The unit does not operate. | The fuse in the control box is not blown. | The power lamp on the circuit board is not lit. | The main power is not turned on. Switch on the power. |
| | | The power lamp on the circuit board is lit. | The pump interlock circuit is not connected. The flow switch wiring is not connected. Connect the pump interlock circuit wiring to the system. Connect the flow switch wiring to the system. |
| | The fuse in the control box is blown. | Measure the circuit resistance and the earth resistance. | Short-circuited circuit or ground fault Resolve the cause, and replace the fuse. |
| | Automatic Start/Stop thermistor has tripped. | Water temperature is high. | Normal |
| | | Water temperature is low. | The setting for the automatic Start/Stop thermistor is too low. Change the setting for the automatic Start/Stop thermistor. |
| The unit is in operation, but the water does not heat up. | Water temperature is low. | The water inlet/outlet temperature differential is normal. | The water-heating load is too high. Install more units. |
| | | The water inlet/outlet temperature differential is small. | Low refrigerant charge due to a leak. Perform a leakage test, repair the leaks, evacuate the system, and charge the refrigerant circuit with refrigerant. |
| | | | LEV fault in the main circuit Replace the LEV in the main circuit. |
| | Water temperature is high. | Compressor failure Replace the compressor. | |
| | | High pressure is too high, or low pressure is too low. Operate the units within the specified pressure range. | |
| Water temperature is high. | Water flow shortage Increase the water flow rate. | | |
| | Problem with the external devices Repair the devices. | | |

[2] Diagnosing Problems Using Error Codes

If a problem occurs, please check the following before calling for service.

- (1) Check the error code against the table below.
- (2) Check for possible causes of problems listed in the "Cause" column that correspond to the error code.
- (3) If the error codes that appear on the display are not listed in the table below, or no problems were found with the items listed in the "Cause" column, please consult your dealer or servicer.

Diagnosing Problems Using Error Codes

| Error code *1 (PCB *2) | Error type | | Cause (Installation/Setting error) | Cause (Parts problems) | Error reset *3 | |
|-------------------------------|--|---|--|--|--------------------|--------------|
| | | | | | Unit side (PCB) | Remote |
| | | | | | SWS1 | Operation SW |
| R000 | Unreset errors | | *4 Some of the errors have not been reset. | | — | — |
| R-P0 | Power failure | | *5 Power failure occurred when the operation switch is switched on. | | ⊙ | ⊙ |
| RFSR | Water supply cutoff (Flow switch has been triggered.) | | The water flow rate dropped below the flow switch threshold. Water supply cutoff | <ul style="list-style-type: none"> • Open-circuited flow switch • Broken flow switch wiring | ○ | ○ |
| RHP1 | High pressure fault | | No water Water supply cutoff | <ul style="list-style-type: none"> • Linear expansion valve fault • High-pressure sensor fault | ○ | ○ |
| RdSH | Compressor flooding | | | <ul style="list-style-type: none"> • Fan motor fault/broken fan motor wiring • Low-pressure sensor fault • Shell temperature thermistor fault • High-pressure sensor fault • Discharge refrigerant temperature thermistor fault • Linear expansion valve fault • Hot gas solenoid valve fault | ○ | ○ |
| I303 | Suction pressure fault | | The outside temperature was below the operating range. Sudden frosting or heavy snow clogged up the air-refrigerant heat exchanger. | <ul style="list-style-type: none"> • Low-pressure sensor fault • Air-refrigerant heat exchanger inlet thermistor fault • Suction refrigerant temperature thermistor fault • LEV bypass check valve fault • Linear expansion valve fault • Fan motor fault/broken fan motor wiring • Refrigerant deficiency (refrigerant gas leak) | ○ | ○ |
| I103 | Shell temperature fault | | The outside temperature was above the upper limit of the operating range. Excessive oil flow | <ul style="list-style-type: none"> • Shell temperature thermistor fault • Linear expansion valve fault | ○ | ○ |
| S109 | Ther- mistor fault | Outside temperature (TH9) | | • Broken or shorted thermistor wiring | ○ | ○ |
| S110 | | Inlet water temperature (TH10 MAIN Circuit) | | • Broken or shorted thermistor wiring | ○ | ○ |
| S112 | | Inlet water temperature (TH12 SUB Circuit) | | | ○ | ○ |
| S111 | | Outlet water temperature (TH11 MAIN Circuit) | | • Broken or shorted thermistor wiring | ○ | ○ |
| S113 | | Outlet water temperature (TH13 SUB Circuit) | | | ○ | ○ |
| S103 | | Shell temperature (TH3 MAIN Circuit) | | • Broken or shorted thermistor wiring | ○ | ○ |
| S107 | | Shell temperature (TH7 SUB Circuit) | | | ○ | ○ |
| S101 | | Discharge temperature (TH1 MAIN Circuit) | | • Broken or shorted thermistor wiring | ○ | ○ |
| S105 | | Discharge temperature (TH5 SUB Circuit) | | | ○ | ○ |
| S102 | | Inlet temperature (TH2 MAIN Circuit) | | • Broken or shorted thermistor wiring | ○ | ○ |
| S106 | | Inlet temperature (TH6 SUB Circuit) | | | ○ | ○ |
| S104 | | Air-refrigerant heat exchanger inlet temperature (TH4 MAIN Circuit) | | • Broken or shorted thermistor wiring | ○ | ○ |
| S108 | | Air-refrigerant heat exchanger inlet temperature (TH8 SUB Circuit) | | | ○ | ○ |
| S114 | Representative water temperature (TH14) | | • Broken or shorted thermistor wiring | ○ | ○ | |
| S115 | Representative water temperature (TH15) | | • Broken or shorted thermistor wiring | ○ | ○ | |
| S117 | High-pressure sensor fault/high-pressure fault | | | • Broken or shorted pressure sensor wiring | ○ | ○ |
| S118 | Low-pressure sensor fault/low-pressure fault | | | • Broken or shorted pressure sensor wiring | ○ | ○ |
| 7113 | Model setting error 1 | | Dip switches on the PCB were set incorrectly during maintenance. | | × | × |
| 7117 | Model setting error 2 | | | • Resistor R21 fault (connected to the Main control board) | × | × |
| 4115 | Power supply frequency fault | | Power supply frequency is a frequency other than 50 Hz or 60 Hz. | | × | × |
| R471 | Open phase | | There is an open phase. | • Circuit board fault | × | × |
| 4106 (255) | Power supply fault | | | • Transmission power supply PCB fault | — | — |
| 4121 | Active filter fault | | | • Active filter fault | ⊙ | ⊙ |
| RCE1 (Preliminary RCE1) | Discharge temperature fault (A discharge refrigerant temperature of 120°C or above is detected for 30 seconds while the compressor is in operation.) (A discharge refrigerant temperature of 125°C or above is detected momentarily while the compressor is in operation.) | | No water Abrupt change in water temperature (5K/min. or greater) Pump failure | <ul style="list-style-type: none"> • High-pressure sensor fault • Linear expansion valve fault (Main circuit LEV, injection LEV) • Injection solenoid valve fault • Refrigerant deficiency (refrigerant gas leak) | ○ | ○ |

| Error code *1 (PCB *2) | Error type | | Cause (Installation/Setting error) | Cause (Parts problems) | Error reset *3 | |
|---------------------------|---|---|--|--|--------------------|--------------|
| | | | | | Unit side (PCB) | Remote |
| | | | | | SWS1 | Operation SW |
| 1104 | Heat exchanger freeze up *6 | | Drop in water flow or water supply cutoff during the defrost cycle Water temperature drop during defrost cycle | • 4-way valve switching failure | ○ | ○ |
| 4250 4255 (101) | Inverter error | Electric current related errors during operation | IPM error | • INV board fault • Ground fault of the compressor • Coil problem • IPM error (loose terminal screws, cracked due to swelling) • Items listed under "Heatsink overheat protection" below | ○ | ○ |
| 4250 4255 (102) | | ACCT overcurrent | | • INV board fault • Ground fault of the compressor • Coil problem | ○ | ○ |
| 4250 4255 (103) | | DCCT overcurrent | | • IPM error (loose terminal screws, cracked due to swelling) | ○ | ○ |
| 4250 4255 (107) | | Overcurrent relay trip (effective value) (During operation) | | | ○ | ○ |
| 4250 4255 (106) | | Overcurrent relay trip (momentary value) (During operation) | | | ○ | ○ |
| 4250 4255 (104) | | Short-circuited IPM/ground fault (During operation) | | • Ground fault of the compressor • IPM error (loose terminal screws, cracked due to swelling) | ○ | ○ |
| 4250 4255 (105) | | Overcurrent error due to a short-circuited (During operation) | Inter-phase voltage drop (Inter-phase voltage at or below 180 V) | • Ground fault of the compressor • Shorted output wiring | ○ | ○ |
| 4250 4255 (101) | Current-related problems at start up | IPM error (At startup) | | • INV board fault • Ground fault of the compressor • Coil problem • IPM error (loose terminal screws, cracked due to swelling) • Items listed under "Heatsink overheat protection" below | ○ | ○ |
| 4250 4255 (102) | | ACCT overcurrent (At startup) | | • INV board fault • Ground fault of the compressor • Coil problem | ○ | ○ |
| 4250 4255 (103) | | DCCT overcurrent (At startup) | | • IPM error (loose terminal screws, cracked due to swelling) | ○ | ○ |
| 4250 4255 (107) | | Overcurrent relay trip (effective value) (At startup) | | | ○ | ○ |
| 4250 4255 (106) | | Overcurrent relay trip (momentary value) (At startup) | | | ○ | ○ |
| 4220 4225 (108) | Voltage-related problems during operation | Bus voltage drop protection | Momentary power failure/power failure Power supply voltage drop (Inter-phase voltage is 180 V or below.) Voltage drop | • INV board CNDC2 wiring fault • INV board fault • 72C fault • Diode stack failure | ○ | ○ |
| 4220 4225 (109) | | Bus voltage rise protection | Incorrect power supply voltage | • INV board fault | ○ | ○ |
| 4220 4225 (111) | | Logic error | Malfunction due to external noise interference • Faulty grounding • Improper transmission and external wiring installation (Shielded cable is not used.) • Low-voltage signal wire and high-voltage wire are in contact. (Placing the signal wire and power wire in the same conduit) | • INV board fault | ○ | ○ |
| 4220 4225 (131) | | Voltage meter error at start up (Bus voltage drop protection at start up (detected by the Main unit side)) | Power supply voltage drop | • PCB fault | ○ | ○ |
| 4230 4235 | | Heatsink fault (Heatsink overheat protection) | Power supply voltage drop (Inter-phase voltage is 180 V or below.) Clogged heatsink cooling air passage | • Fan motor fault • INV board fan output fault • THHS sensor fault • IPM error (loose terminal screws, cracked due to swelling) | ○ | ○ |
| 4240 4245 | | Overload protection | Short-cycling of air (reduced air flow) Clogged heatsink cooling air passage Power supply voltage drop (Inter-phase voltage is 180 V or below.) | • THHS sensor fault • Current sensor fault • INV board fan output fault • INV circuit fault • Compressor fault | ○ | ○ |
| 5301 5305 (115) | | ACCT sensor fault | | • INV board fault • Ground fault of the compressor and IPM error | ○ | ○ |

| Error code *1 (PCB *2) | Error type | Cause (Installation/Setting error) | Cause (Parts problems) | Error reset *3 | |
|---------------------------|--|--|--|---|--------------|
| | | | | Unit side (PCB) | Remote |
| | | | | SWS1 | Operation SW |
| 5301 5305 (116) | Inverter error | DCCT sensor | <ul style="list-style-type: none"> Poor contact at the INV board connector CNCT Poor contact at the INV board connector DCCT Ground fault of the compressor and IPM error | ○ | ○ |
| 5301 5305 (117) | | ACCT sensor/circuit fault | <ul style="list-style-type: none"> Poor contact at the INV board connector CNCT2 (ACCT) ACCT sensor fault | ○ | ○ |
| 5301 5305 (118) | | DCCT sensor/circuit fault | <ul style="list-style-type: none"> Poor contact at the INV board connector CNCT Poor contact at the INV board connector DCCT DCCT sensor fault INV board fault | ○ | ○ |
| 5301 5305 (119) | | Open-circuited IPM/loose ACCT sensor | <ul style="list-style-type: none"> Disconnected ACCT sensor (CNCT2) ACCT sensor fault Broken compressor wiring INV circuit fault (IPM error etc.) | ○ | ○ |
| 5301 5305 (120) | | Faulty wiring | <ul style="list-style-type: none"> ACCT sensor is connected in the wrong phase. ACCT sensor is connected in the wrong orientation. | ○ | ○ |
| 5110 (01) (05) | | THHS sensor/circuit fault | <ul style="list-style-type: none"> THHS sensor contact failure THHS sensor fault INV board fault | ○ | ○ |
| 0403 (01) (05) | | Serial communication error | <ul style="list-style-type: none"> Communication error between control board and INV board (noise interference, broken wiring) | ○ | ○ |
| — | | IPM system error | INV board switch setting error | <ul style="list-style-type: none"> Wiring or connector connection between connectors on IPM-driven power supply circuit INV board fault | ○ |
| 7105 | Multiple unit system error | Address setting error | Address setting error (Non-consecutive address) | × | × |
| 7130 | | Incompatible combination of units | Different types of units are connected to the same system. | × | × |
| 7102 | | No.-of-connected-unit setting is incorrect. | No.-of-connected-unit setting is incorrect (Main unit). | × | × |
| 6500 | Communication error between the main and sub units Communication error between the MAIN and SUB circuits | | | — | — |
| 6600 | Transmission line power supply PCB fault Communication error between the main and sub units (Simple multiple unit control mode) *7 | Communication error due to external noise interference | <ul style="list-style-type: none"> Broken wiring to the transmission power supply circuit board (between the main and sub units) Transmission power supply PCB communication circuit fault | × | × |
| 6602 | | | | — | — |
| 6603 | | | | — | — |
| 6606 | | | | — | — |
| 6607 | | | | — | — |
| 6608 | — | — | — | — | |

*1: The codes in the parentheses in the "Error code" column indicate error detail codes.

*2: If an error occurs, error codes shown above will appear in the 4-digit digital display on the PCB.

*3: Definition of symbols in the "Error reset" column.

- ⊙ : Errors that can be reset regardless of the switch settings
- : Errors that cannot be reset if the remote reset setting on the unit is set to "Enable" (factory setting)
Errors that cannot be reset if the remote reset setting on the unit is set to "Disable"
- ×
- : Errors that will be automatically cancelled once its cause is removed

*4: Power failure will be detected as an error only when the "Automatic recovery after power failure" setting on the unit is set to "Disable."
(The default setting for the "Automatic recovery after power failure" setting is "Enable.")

*5: Depending on the system configuration, if communication error lasts for 10 minutes or longer, units will make an abnormal stop.
This error can be reset by turning off and then back on the unit's power.

*6: This error code will appear when multiple errors occur that are reset in different ways and when one or more of these errors have not been reset. This error can be reset by turning off and then back on the unit's power.

*7: Before resetting this error, remove its causes. Resuming operation without removing the causes of heat exchanger freeze up will cause heat exchanger damage.

[3] Calling for Service

If the problem cannot be solved by following the instructions provided in the table above, please contact your dealer or servicer along with the types of information listed below.

- (1) **Model name**
The model name is a string that starts with "CAHV" and is found on the lower part of the left side of the unit.
- (2) **Serial number**
Example: 75W00001
- (3) **Error code**
- (4) **Nature of the problem in detail**
Example: The unit stops approximately one minute after it was started.

7. Operating the Unit

[1] Initial Operation

1. Make sure the Run/Stop switch that controls the unit on the local control panel is switched off.
2. Switch on the main power.
3. Leave the main power switched on for at least 12 hours before turning on the Run/Stop switch that controls the unit on the on-site control panel to warm up the compressor.
4. Switch on the Run/Stop switch that controls the unit on the on-site control panel.

[2] Daily Operation

To start an operation

Switch on the Run/Stop switch that controls the unit on the local control panel, or press the ON/OFF button on the remote controller. (*1)

Note

The unit described in this manual features a circuit that protects the compressor from short-cycling. Once the compressor stops, it will not start up again for up to 10 minutes. If the unit does not start when the ON/OFF switch is turned on, leave the switch turned on for 10 minutes. The unit will automatically start up within 10 minutes.

To stop an operation

Switch off the Run/Stop switch that controls the unit on the on-site control panel, or press the ON/OFF button on the remote controller. (*1)

Refer to the following pages for how to use the remote controller.

IMPORTANT

- Keep the main power turned on throughout the operating season, in which the unit is stopped for three days or shorter (e.g., during the night and on weekends).
- Unless in areas where the outside temperature drops to freezing, switch off the main power when the unit will not be operated for four days or longer. (Switch off the water circulating pump if the pump is connected to a separate circuit.)
- When resuming operation after the main power has been turned off for a full day or longer, follow the steps under “Initial Operation” above.
- If the main power was turned off for six days or longer, make sure that the clock on the unit is correct.

[3] How to operate

<1> Using the Remote Controller

How to Start, Stop, Change the Mode, and Adjust the Water Temperature

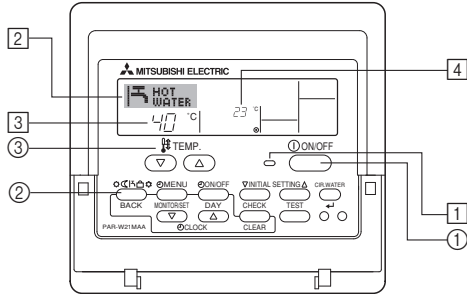

To Start Operation

1. Press the ON/OFF button ①.
The ON lamp ① and the display area come on.

Note:

- When the unit is restarted, initial settings are as follows.

| | Remote Controller settings |
|---------------------|----------------------------|
| Mode | Last operation mode |
| Temperature setting | Last set temperature |

To Stop Operation

1. Press the ON/OFF button ① again.
The ON lamp ① and the display area go dark.

Selecting the Mode

1. With the unit running, press the Mode button ② as many times as necessary.
 - Each press switches operation to the next mode, in the sequence shown below.
 - The currently selected mode is shown at ②.

To Change the Temperature Setting...

- To lower the temperature: Press the (▽) Set Temperature button ③.
- To raise the temperature: Press the (△) Set Temperature button ③.
 - Each press changes the setting by 1 °C (1 °F). The current setting is displayed at ③.
 - The available ranges are as follows. *1, *2

| Hot Water | Heating |
|---------------------------------|---------------------------------|
| 30 °C - 70 °C 87 °F - 158 °F | 30 °C - 45 °C 87 °F - 113 °F |

Note:

- *1 Available ranges vary according to the type of unit connected.
- *2 If temperature range limits have been set at Function Selection of remote controller, the available ranges will be narrower than shown above. If you attempt to set a value outside of the restricted range, the display will show a message indicating that the range is currently restricted. For information about how to set and clear these range limits, refer to section 3, item [3]-2 (3).
- *3 If Function Selection of remote controller are set to display the temperature in Fahrenheit. For information about how to select °C or °F, refer to section 3, item [3]-4 (1).

<2> Water temperature adjustment

To change water temperature

Press the (Ⓞ) [water temperature adjustment] button and set the water temperature of your choice.

Pressing (△) or (▽) once changes the setting by 1 °C. If the pressing is continued, the setting continues to change by 1 °C.

- Indoor temperature can be set within the following range.

| Hot Water | Heating |
|---------------------------------|---------------------------------|
| 30 °C - 70 °C 87 °F - 158 °F | 30 °C - 45 °C 87 °F - 113 °F |

- It is impossible to set the water temperature by the Inlet Water Temp. or Outlet Water Temp.
- * The range of water temperature display is 0 °C to 100 °C. Outside this range, the display flashes either 0 °C or 100 °C to inform you if the water temperature is lower or higher than the displayed temperature.

<3> Setting the Day of the Week and Time

Use this screen to change the current day of the week and time setting.

Note:

The day and time will not appear if clock use has been disabled at Function Selection of remote controller.

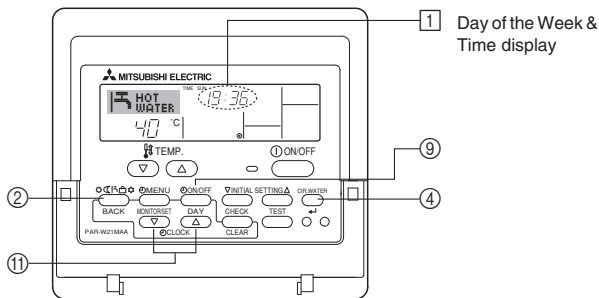

How to Set the Day of the Week and Time...

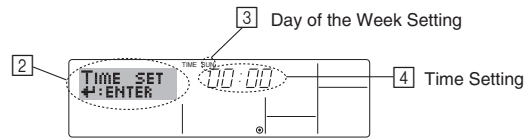

- Press the (▽) or (△) Set Time button ① to show display ②.
- Press the TIMER ON/OFF (SET DAY) button ② to set the day.
 - * Each press advances the day shown at ③: Sun → Mon → ... → Fri → Sat.
- Press the appropriate Set Time button ① as necessary to set the time.
 - * As you hold the button down, the time (at ④) will increment first in minute intervals, then in ten-minute intervals, and then in one-hour intervals.
- After making the appropriate settings at Steps 2 and 3, press the CIR.WATER ↵ button ④ to lock in the values.

Note:

Your new entries at Steps 2 and 3 will be cancelled if you press the Mode (Return) button ② before pressing the CIR.WATER ↵ button ④.

- Press the Mode (Return) button ② to complete the setting procedure. This will return the display to the standard control screen, where ① will now show the newly set day and time.

<4> Using the Timer

This section explains how to set and use the timer. You can use Function Selection of remote controller to select which of three types of timer to use: ① Weekly timer, ② Simple timer, or ③ Auto Off timer.

For information about how to set the Function Selection of remote controller, refer to section 3, item [3]-3 (3).

Using the Weekly Timer

- The weekly timer can be used to set up to six operations for each day of the week.
 - Each operation may consist of any of the following: ON/OFF time together with a temperature setting, or ON/OFF time only, or temperature setting only.
 - When the current time reaches a time set at this timer, the unit carries out the action set by the timer.
- Time setting resolution for this timer is 1 minute.

Note:

- *1. Weekly Timer/Simple Timer/Auto Off Timer cannot be used at the same time.
- *2. The weekly timer will not operate when any of the following conditions is in effect.

The timer feature is off; the system is in a malfunction state; a test run is in progress; the remote controller is undergoing self-check or remote controller check; the user is in the process of setting a function; the user is in the process of setting the timer; the user is in the process of setting the current day of the week or time; the system is under central control. (Specifically, the system will not carry out operations (unit on, unit off, or temperature setting) that are prohibited during these conditions.)

Operation No.

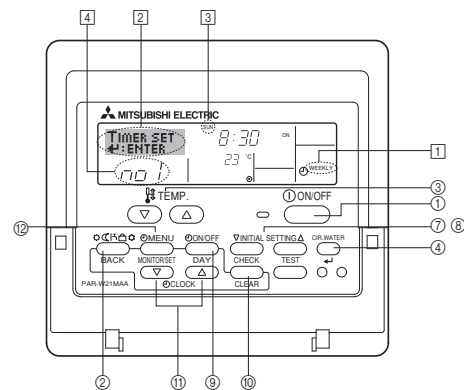

How to Set the Weekly Timer

1. Be sure that you are at a standard control screen, and that the weekly timer indicator **1** is shown in the display.
2. Press the TIMER MENU button **12**, so that the "Set Up" appears on the screen (at **2**). (Note that each press of the button toggles the display between "Set Up" and "Monitor".)
3. Press the TIMER ON/OFF (SET DAY) button **9** to set the day. Each press advances the display at **3** to the next setting, in the following sequence: "Sun Mon Tues Wed Thurs Fri Sat" → "Sun" → ... → "Fri" → "Sat" → "Sun Mon Tues Wed Thurs Fri Sat"...
4. Press the **▽** or **△** INITIAL SETTING button (**7** or **8**) as necessary to select the appropriate operation number (1 to 6) **4**.
 - * Your inputs at Steps 3 and 4 will select one of the cells from the matrix illustrated below.
 - (The remote-controller display at left shows how the display would appear when setting Operation 1 for Sunday to the values indicated below.)

Setup Matrix

| Op No. | Sunday | Monday | ... | Saturday |
|--------|--------------------------------|------------------|------------------|------------------|
| No. 1 | • 8:30 • ON • 23°C(73°F) | | | |
| No. 2 | • 10:00 • OFF | • 10:00 • OFF | • 10:00 • OFF | • 10:00 • OFF |
| ... | | | | |
| No. 6 | | | | |

<Operation 1 settings for Sunday>
Start the unit at 8:30, with the temperature set to 23 °C (73 °F).

<Operation 2 settings for every day>
Turn off the unit at 10:00.

Note:

By setting the day to "Sun Mon Tues Wed Thurs Fri Sat", you can set the same operation to be carried out at the same time every day. (Example: Operation 2 above, which is the same for all days of the week.)

Setting the Weekly Timer

Shows the time setting **5** **6** Shows the selected operation (ON or OFF)
* Does not appear if operation is not set.

Shows the temperature setting **7**
* Does not appear if temperature is not set.

5. Press the appropriate Set Time button **11** as necessary to set the desired time (at **5**).
 - * As you hold the button down, the time first increments in minute intervals, then in ten-minute intervals, and then in one-hour intervals.
6. Press the ON/OFF button **1** to select the desired operation (ON or OFF), at **6**.
 - * Each press changes the next setting, in the following sequence: No display (no setting) → "ON" → "OFF"
7. Press the appropriate Set Temperature button **3** to set the desired temperature (at **7**).
 - * Each press changes the setting, in the following sequence: No display (no setting) ⇔ 5 (41) ⇔ 6 (43) ⇔ ... ⇔ 89 (192) ⇔ 90 (194) ⇔ No display. (Available range: The range for the setting is 5 °C (41 °F) to 90 °C (194 °F). The actual range over which the temperature can be controlled, however, will vary according to the type of the connected unit.)
8. To clear the currently set values for the selected operation, press and quickly release the CHECK (CLEAR) button **10** once.
 - * The displayed time setting will change to "—:—", and the ON/OFF and temperature settings will all disappear.
 - (To clear all weekly timer settings at once, hold down the CHECK (CLEAR) button **10** for two seconds or more. The display will begin flashing, indicating that all settings have been cleared.)
9. After making the appropriate settings at Steps 5, 6, and 7, press the CIR.WATER **↵** button **4** to lock in the values.

Note:

- Your new entries will be cancelled if you press the Mode (Return) button **2** before pressing the CIR.WATER **↵** button **4**.
- If you have set two or more different operations for exactly the same time, only the operation with the highest Operation No. will be carried out.
10. Repeat Steps 3 to 8 as necessary to fill as many of the available cells as you wish.
 11. Press the Mode (Return) button **2** to return to the standard control screen and complete the setting procedure.
 12. To activate the timer, press the TIMER ON/OFF button **9**, so that the "Timer Off" indication disappears from the screen. **Be sure that the "Timer Off" indication is no longer displayed.**
 - * If there are no timer settings, the "Timer Off" indication will flash on the screen.

How to View the Weekly Timer Settings

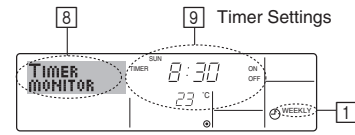

1. Be sure that the weekly timer indicator is visible on the screen (at **1**).
2. Press the TIMER MENU button **12** so that "Monitor" is indicated on the screen (at **8**).
3. Press the TIMER ON/OFF (SET DAY) button **9** as necessary to select the day you wish to view.
4. Press the **▽** or **△** INITIAL SETTING (**7** or **8**) as necessary to change the timer operation shown on the display (at **9**).
 - * Each press will advance to the next timer operation, in order of time setting.
5. To close the monitor and return to the standard control screen, press the Mode (Return) button **2**.

To Turn Off the Weekly Timer

Press the TIMER ON/OFF button **9** so that "Timer Off" appears at **10**.

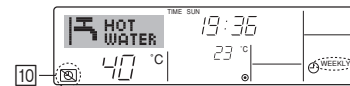

To Turn On the Weekly Timer

Press the TIMER ON/OFF button **9** so that the "Timer Off" indication (at **10**) goes dark.

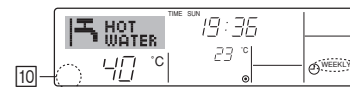

Using the Simple Timer

1. You can set the simple timer in any of three ways.
 - Start time only : The unit starts when the set time has elapsed.
 - Stop time only : The unit stops when the set time has elapsed.
 - Start & stop times : The unit starts and stops at the respective elapsed times.
2. The simple timer (start and stop) can be set only once within a 72-hour period. The time setting is made in hour increments.

Note:

- *1. Weekly Timer/Simple Timer/Auto Off Timer cannot be used at the same time.
- *2. The simple timer will not operate when any of the following conditions is in effect. The timer is off; the system is in malfunction state; a test run is in progress; the remote controller is undergoing self-check or remote controller check; the user is in the process of selecting a function; the user is in the process of setting the timer; the system is under central control. (Under these conditions, ON/OFF operation is prohibited.)

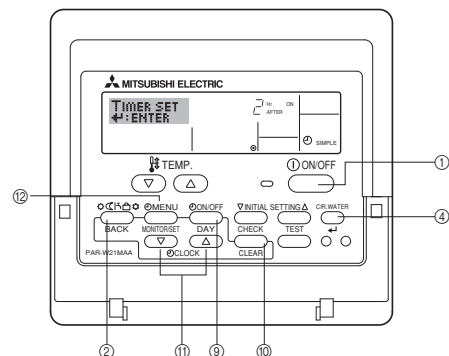

How to Set the Simple Timer

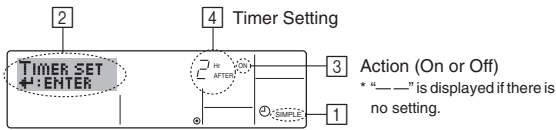

- Be sure that you are at a standard control screen, and that the simple timer indicator is visible in the display (at [1]).
When something other than the Simple Timer is displayed, set it to SIMPLE TIMER using the function selection of remote controller (see 3.[3]-3 (3)) timer function setting.
- Press the TIMER MENU button [2], so that the "Set Up" appears on the screen (at [2]). (Note that each press of the button toggles the display between "Set Up" and "Monitor".)
- Press the ON/OFF button [1] to display the current ON or OFF simple timer setting. Press the button once to display the time remaining to ON, and then again to display the time remaining to OFF. (The ON/OFF indication appears at [4]).
 - "ON" timer: The unit will start operation when the specified number of hours has elapsed.
 - "OFF" timer: The unit will stop operation when the specified number of hours has elapsed.
- With "ON" or "OFF" showing at [3]: Press the appropriate Set Time button [1] as necessary to set the hours to ON (if "ON" is displayed) or the hours to OFF (if "OFF" is displayed) at [4].
 - Available Range: 1 to 72 hours
- To set both the ON and OFF times, repeat Steps 3 and 4.
* Note that ON and OFF times cannot be set to the same value.
- To clear the current ON or OFF setting: Display the ON or OFF setting (see step 3) and then press the CHECK (CLEAR) button [1] so that the time setting clears to "—" at [4]. (If you want to use only an ON setting or only an OFF setting, be sure that the setting you do not wish to use is shown as "—".)
- After completing steps 3 to 6 above, press the CIR.WATER button [4] to lock in the value.

Note:

Your new settings will be cancelled if you press the Mode (Return) button [2] before pressing the CIR.WATER button [4].

- Press the Mode (Return) button [2] to return to the standard control screen.
- Press the TIMER ON/OFF button [9] to start the timer countdown. When the timer is running, the timer value is visible on the display. **Be sure that the timer value is visible and appropriate.**

Viewing the Current Simple Timer Settings

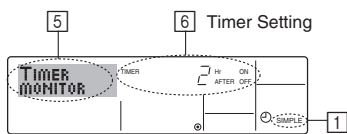

- Be sure that the simple timer indicator is visible on the screen (at [1]).
- Press the TIMER MENU button [2], so that the "Monitor" appears on the screen (at [5]).
 - If the ON or OFF simple timer is running, the current timer value will appear at [6].
 - If ON and OFF values have both been set, the two values appear alternately.
- Press the Mode (Return) button [2] to close the monitor display and return to the standard control screen.

To Turn Off the Simple Timer...

Press the TIMER ON/OFF button [9] so that the timer setting no longer appears on the screen (at [7]).

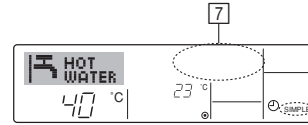

To Turn On the Simple Timer...

Press the TIMER ON/OFF button [9] so that the timer setting becomes visible at [7].

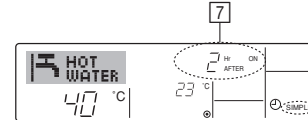

Examples

If ON and OFF times have both been set at the simple timer, operation and display are as indicated below.

Example 1:

Start the timer, with ON time set sooner than OFF time
ON Setting: 3 hours
OFF Setting: 7 hours

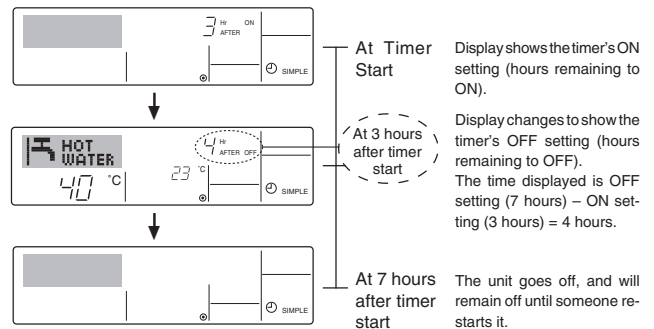

Example 2:

Start the timer, with OFF time is sooner than ON time
ON Setting: 5 hours
OFF Setting: 2 hours

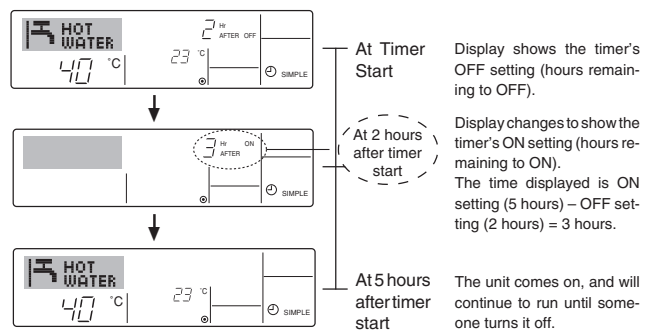

Using the Auto Off Timer

1. This timer begins countdown when the unit starts, and shuts the unit off when the set time has elapsed.
2. Available settings run from 30 minutes to 4 hours, in 30-minute intervals.

Note:

- *1. Weekly Timer/Simple Timer/Auto Off Timer cannot be used at the same time.
- *2. The Auto Off timer will not operate when any of the following conditions is in effect.

The timer is off; the system is in malfunction state; a test run is in progress; the remote controller is undergoing self-check or remote controller check; the user is in the process of selecting a function; the user is in the process of setting the timer; the system is under central control. (Under these conditions, ON/OFF operation is prohibited.)

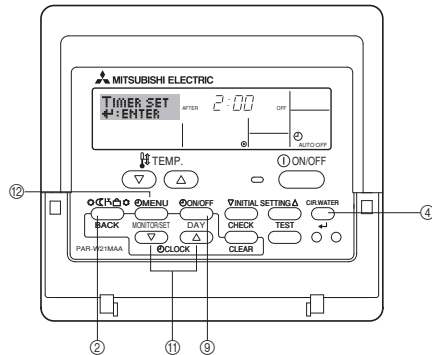

How to Set the Auto Off TIMER

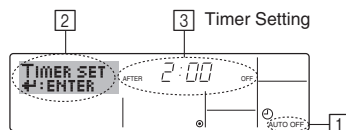

1. Be sure that you are at a standard control screen, and that the Auto Off timer indicator is visible in the display (at 1).
When something other than the Auto Off Timer is displayed, set it to AUTO OFF TIMER using the function selection of remote controller (see 3.[3]-3 (3) timer function setting).
2. Hold down the TIMER MENU button ② for **3 seconds**, so that the "Set Up" appears on the screen (at 2).
(Note that each press of the button toggles the display between "Set Up" and "Monitor".)
3. Press the appropriate Set Time button ⑪ as necessary to set the OFF time (at 3).
4. Press the CIR.WATER button ④ to lock in the setting.

Note:

Your entry will be cancelled if you press the Mode (Return) button ② before pressing the CIR.WATER button ④.

5. Press the Mode (Return) button ② to complete the setting procedure and return to the standard control screen.
6. If the unit is already running, the timer starts countdown immediately. **Be sure to check that the timer setting appears correctly on the display.**

Checking the Current Auto Off Timer Setting

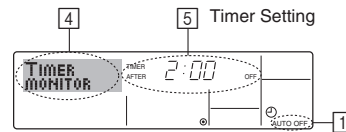

1. Be sure that the "Auto Off" is visible on the screen (at 1).
2. Hold down the TIMER MENU button ② for **3 seconds**, so that "Monitor" is indicated on the screen (at 4).
 - The timer remaining to shutdown appears at 5.
3. To close the monitor and return to the standard control screen, press the Mode (Return) button ②.

To Turn Off the Auto Off Timer...

- Hold down the TIMER ON/OFF button ③ for **3 seconds**, so that "Timer Off" appears (at 6) and the timer value (at 7) disappears.

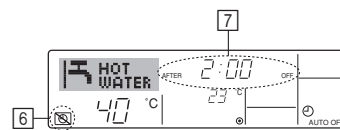

- Alternatively, turn off the unit itself. The timer value (at 7) will disappear from the screen.

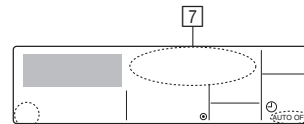

To Turn On the Auto Off Timer...

- Hold down the TIMER ON/OFF button ③ for **3 seconds**. The "Timer Off" indication disappears (at 6), and the timer setting comes on the display (at 7).
- Alternatively, turn on the unit. The timer value will appear at 7.

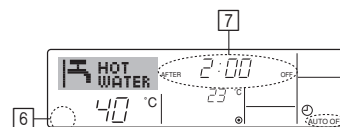

[4] Function Selection

Function selection of remote controller

The setting of the following remote controller functions can be changed using the remote controller function selection mode. Change the setting when needed.

| Item 1 | Item 2 | Item 3 (Setting content) |
|--|--|---|
| 1. Change Language ("CHANGE LANGUAGE") | Language setting to display | <ul style="list-style-type: none"> Display in multiple languages is possible |
| 2. Function limit ("FUNCTION SELECTION") | (1) Operation function limit setting (operation lock) ("LOCKING FUNCTION") | <ul style="list-style-type: none"> Setting the range of operation limit (operation lock) |
| | (2) Operation mode skip setting ("SELECT MODE") | <ul style="list-style-type: none"> Setting the use or non-use of each operation mode |
| | (3) Temperature range limit setting ("LIMIT TEMP FUNCTION") | <ul style="list-style-type: none"> Setting the temperature adjustable range (maximum, minimum) |
| 3. Mode selection ("MODE SELECTION") | (1) Remote controller main/sub setting ("CONTROLLER MAIN/SUB") | <ul style="list-style-type: none"> Selecting main or sub remote controller * When two remote controllers are connected to one group, one controller must be set to sub. |
| | (2) Use of clock setting ("CLOCK") | <ul style="list-style-type: none"> Setting the use or non-use of clock function |
| | (3) Timer function setting ("WEEKLY TIMER") | <ul style="list-style-type: none"> Setting the timer type |
| | (4) Contact number setting for error situation ("CALL.") | <ul style="list-style-type: none"> Contact number display in case of error Setting the telephone number |
| | (5) Temp off set setting ("TEMP OFF SET FUNCTION") | <ul style="list-style-type: none"> Setting the use or non-use of setback amount setting |
| 4. Display change ("DISP MODE SETTING") | (1) Temperature display °C/°F setting ("TEMP MODE °C/°F") | <ul style="list-style-type: none"> Setting the temperature unit (°C or °F) to display |
| | (2) Water temperature display setting ("WATER TEMP DISP SELECT") | <ul style="list-style-type: none"> Setting the use or non-use of the display of water temperature |

Function selection flowchart

[1] Stop the unit to start remote controller function selection mode. → [2] Select from item 1. → [3] Select from item 2. → [4] Make the setting. (Details are specified in item 3) → [5] Setting completed. → [6] Change the display to the normal one. (End)

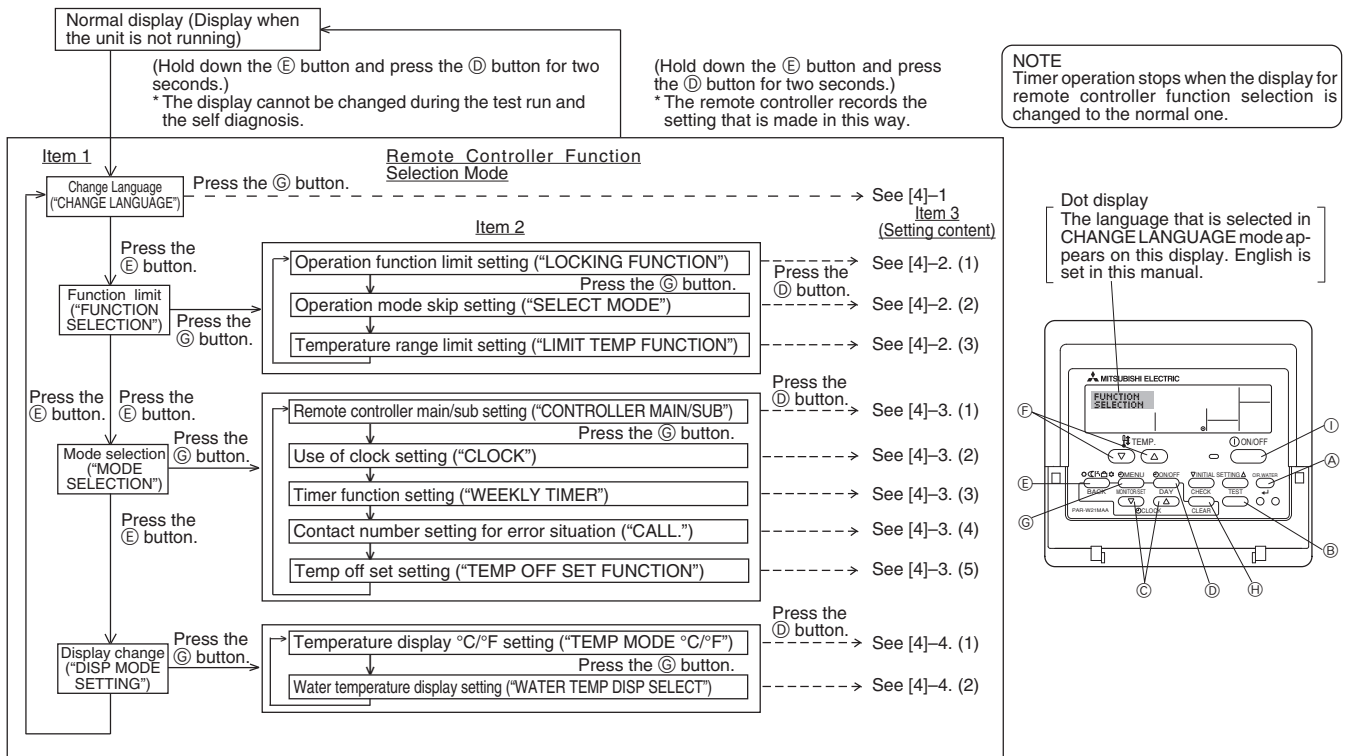

Detailed setting

[4]–1. CHANGE LANGUAGE setting

The language that appears on the dot display can be selected.

- Press the [MENU] button to change the language.
 - ① English (GB), ② German (D), ③ Spanish (E), ④ Russian (RU), ⑤ Italian (I), ⑥ French (F), ⑦ Swedish

[4]–2. Function limit

(1) Operation function limit setting (operation lock)

- To switch the setting, press the [ON/OFF] button.
 - ① no1 : Operation lock setting is made on all buttons other than the [ON/OFF] button.
 - ② no2 : Operation lock setting is made on all buttons.
 - ③ OFF (Initial setting value) : Operation lock setting is not made.

* To make the operation lock setting valid on the normal screen, it is necessary to press buttons (Press and hold down the [CIR.WATER] and [ON/OFF] buttons at the same time for two seconds.) on the normal screen after the above setting is made.

(2) Operation mode skip setting

After setting is changed, the operation mode can not be changed within the changed range.

- To switch the following settings, press the [ON/OFF] button.
 - ① Heating mode : Sets the use or non-use of the Heating mode.
 - ② Heating ECO mode : Sets the use or non-use of the Heating ECO mode.
 - ③ Hot Water mode : Sets the use or non-use of the Hot Water mode.
 - ④ Anti-freeze mode : Sets the use or non-use of the Anti-freeze mode.
 - ⑤ Cooling mode : Sets the use or non-use of the Cooling mode.
 - ⑥ OFF (Initial setting value) : Operation mode skip is not executed.

* When the setting, other than OFF, is made, the skip settings of the Heating, Heating ECO, Hot Water, Anti-freeze, and Cooling modes are executed at the same time.

* A mode that is not available on the unit to connect cannot be used even if the setting is "AVAILABLE."

(3) Temperature range limit setting

After this setting is made, the temperature can be changed within the set range.

- To switch the setting, press the [ON/OFF] button.
 - ① LIMIT TEMP HEATING MODE:
The temperature range can be changed on heating mode.
 - ② LIMIT TEMP HOT WATER MODE:
The temperature range can be changed on heating/hot water mode.
 - ③ LIMIT TEMP ANTI-FREEZE MODE:
The temperature range can be changed on anti-freeze mode.
 - ④ LIMIT TEMP COOLING MODE:
The temperature range can be changed on cooling mode.
 - ⑤ OFF (Initial setting) : The temperature range limit is not active.

* When the setting, other than OFF, is made, the temperature range limit setting on hot water, anti-freeze and cooling mode is made at the same time. However, the range cannot be limited when the set temperature range has not changed.

 - To increase or decrease the temperature, press the [TEMP. ∇] or [TEMP. Δ] button.

| | |
|----------------|---|
| Settable range | |
| Hot Water mode | : Lower limit: 30 ~70 °C (87 ~158 °F) Upper limit: 70 ~30 °C (158 ~ 87 °F) |
| Heating mode | : Lower limit: 30 ~45 °C (87 ~113 °F) Upper limit: 45 ~30 °C (113 ~ 87 °F) |
| Cooling mode | : Lower limit: 10 ~30 °C (50 ~ 87 °F) Upper limit: 30 ~10 °C (87 ~ 50 °F) |

* The settable range varies depending on the unit to connect.

[4]–3. Mode selection setting

(1) Remote controller main/sub setting

- To switch the setting, press the [ON/OFF] button ①.
 - ① Main : The controller will be the main controller.
 - ② Sub : The controller will be the sub controller.

(2) Use of clock setting

- To switch the setting, press the [ON/OFF] button ①.
 - ① ON : The clock function can be used.
 - ② OFF : The clock function cannot be used.

(3) Timer function setting

- To switch the setting, press the [ON/OFF] button ① (Choose one of the followings.).
 - ① WEEKLY TIMER (Initial setting value): The weekly timer can be used.
 - ② AUTO OFF TIMER : The auto off timer can be used.
 - ③ SIMPLE TIMER : The simple timer can be used.
 - ④ TIMER MODE OFF : The timer mode cannot be used.

* When the use of clock setting is OFF, the "WEEKLY TIMER" cannot be used.

(4) Contact number setting for error situation

- To switch the setting, press the [ON/OFF] button ①.
 - ① CALL OFF : The set contact numbers are not displayed in case of error.
 - ② CALL ***** : The set contact numbers are displayed in case of error.
CALL_ : The contact number can be set when the display is as shown on the left.
 - Setting the contact numbers
To set the contact numbers, follow the following procedures.
Move the flashing cursor to set numbers. Press the [TEMP. ∇] or [TEMP. Δ] button ② to move the cursor to the right (left). Press the [CLOCK ∇] or [CLOCK Δ] button ③ to set the numbers.

(5) Temp off see. setting

- To switch the following settings, press the [ON/OFF] button ①.
 - ① ON : The setback amount setting is displayed under the water temperature initial setting mode.
 - ② OFF : The setback amount setting is not displayed under the water temperature initial setting mode.

[4]–4. Display change setting

(1) Temperature display °C/°F setting

- To switch the setting, press the [ON/OFF] button ①.
 - ① °C: The temperature unit °C is used.
 - ② °F: The temperature unit °F is used.

(2) Water temperature display setting

- To switch the setting, press the [ON/OFF] button ①.
 - ① ON : The water temperature is displayed.
 - ② OFF : The water temperature is not displayed.

[5] Using the Unit in Sub-freezing or Snowy Conditions

In areas where temperature drops to freezing during the periods of non-use, blow the water out of the pipes or fill the pipes with anti-freeze solution.

Not doing so may cause the water to freeze, resulting in burst pipes and damage to the unit or the furnishings.

In areas where temperature drops to freezing, use an anti-freeze circuit and leave the main power turned on to prevent the water in the water circuit from freezing and damaging the unit or causing water leakage and resultant damage to the furnishings.

In areas where temperature can drop low enough to cause the water in the pipes to freeze, operate the unit often enough to prevent the water from freezing.

Frozen water in the water circuit may cause the water to freeze, resulting in burst pipes and damage to the unit or the furnishings.

- Remove the snow off the unit before switching on the ON/OFF switch.
- In areas where the outside air drops below freezing, leave the main switch turned on even when the unit will not be operated for four days or longer. Leave the switch on the water circulation pump turned on if the pump is connected to a separate circuit.
 - If the unit is left turned off for a while (e.g., overnight) when the outside temperature drops below freezing, the water in the water circuit will freeze and damage the pipes and the heat exchanger.
 - The recommended electric circuit has an anti-freeze circuit. For this circuit to function, the main power must be turned on.
 - If the water circulation pump is connected differently from the recommended way, make sure the circuit has some type of anti-freeze function*.
(* A function that automatically operates the water circulation pump to prevent the water in the circuit from freezing when the water temperature drops.)

8. Main Specifications

| SPECIFICATIONS | | | |
|--|-------------------------------|---------------------------------------|---|
| Model | | CAHV-P500YA-HPB | |
| Power source | | 3-phase 4-wire 380-400-415 V 50/60 Hz | |
| Capacity ¹ | | kW | 45 |
| | | kcal/h | 38700 |
| | | Btu/h | 153540 |
| | Power input | kW | 12.9 |
| | Current input | A | 21.78-20.69-19.94 |
| | COP (kW/kW) | | 3.49 |
| Capacity ² | | kW | 45 |
| | | kcal/h | 38700 |
| | | Btu/h | 153540 |
| | Power input | kW | 25.57 |
| | Current input | A | 43.17-41.01-39.53 |
| | COP (kW/kW) | | 1.76 |
| Maximum current input ³ | | A | 57.77-54.88-52.90 |
| Water pressure drop ¹ | | | 12.9 kPa (1.87 psi) |
| Temperature range ⁴ | Outlet water temperature | | 40-65°C (35-70°C)(25-70°C) 104-149°F (95-158°F)(77-158°F) |
| | Outdoor temperature | D.B. | -20-40°C (-10-40°C)(0-40°C) -4-104°F (14-104°F)(32-104°F) |
| Circulating water volume range | | | 7.5 m ³ /h-15.0 m ³ /h |
| Sound pressure level (measured in an anechoic room) ¹ | | dB (A) | 59 |
| Sound pressure level (measured in an anechoic room) ³ | | dB (A) | 63 |
| Water pipe diameter and type | Inlet | mm (in) | 38.1 (Rc 1 1/2"), screw pipe |
| | Outlet | mm (in) | 38.1 (Rc 1 1/2"), screw pipe |
| External finish | | | Acrylic painted steel sheet <Munsell 5Y 8/1 or similar> |
| External dimensions H x W x D | | mm in | 1710 (1650 not including legs) x 1978 x 759 67.3 (65.0 not including legs) x 77.9 x 29.9 |
| Net weight | | kg (lb) | 526 (1160) |
| Accessories | | | Y-strainer Rc 1 1/2 |
| Design pressure | R407C | MPa | 3.85 |
| | Water | MPa | 0-1.0 |
| Drawing number | Wiring | | KC94G268X01 |
| | External appearance | | KC94G195X01 |
| Heat exchanger | Water-side | | Copper brazed stainless steel sheet |
| | Air-side | | Plate fins and copper tubes |
| Compressor | Type | | Inverter scroll hermetic compressor |
| | Manufacturer | | MITSUBISHI ELECTRIC CORPORATION |
| | Starting method | | Inverter |
| | Motor output | kW | 7.5 x 2 |
| | Case heater | kW | 0.045 X 2 |
| | Lubricant | | MEL 32 |
| Fan | Air flow rate | m ³ /min | 185 x 2 |
| | | L/s | 3083 x 2 |
| | | cfm | 6532 x 2 |
| | External static pressure | | 0 Pa (0 mm H ₂ O) |
| | Type and quantity | | Propeller fan x 2 |
| | Control and driving mechanism | | Inverter control, direct driven by motor |
| Motor output | kW | 0.46 x 2 | |
| HIC (Heat inter-changer) circuit | | | Copper pipe |
| Protection devices | High pressure | | High-pressure sensor and switch set at 3.85 MPa (643 psi) |
| | Inverter circuit | | Overheat and overcurrent protection |
| | Compressor | | Overheat protection |
| | Fan motor | | Thermal switch |
| Defrosting method | | | Auto-defrost mode (Reversed refrigerant cycle) |
| Refrigerant | Type and factory charge | kg | R407C, 5.5 kg x 2 |
| | Flow and temperature control | | LEV and HIC circuit |

- *1 Under normal heating conditions at the outdoor temperature of 7 °CDB/6 °CWB (44.6 °FDB/42.8 °FWB) and the outlet water temperature of 45 °C (113 °F)
- *2 Under normal heating conditions at the outdoor temperature of 7 °CDB/6 °CWB (44.6 °FDB/42.8 °FWB) and outlet water temperature of 70 °C (158 °F)
- *3 Under normal heating conditions at the outdoor temperature of 7 °CDB/6 °CWB (44.6 °FDB/42.8 °FWB) and the unit is set to the “Capacity Priority” mode through the no-voltage A-contact.
- *4

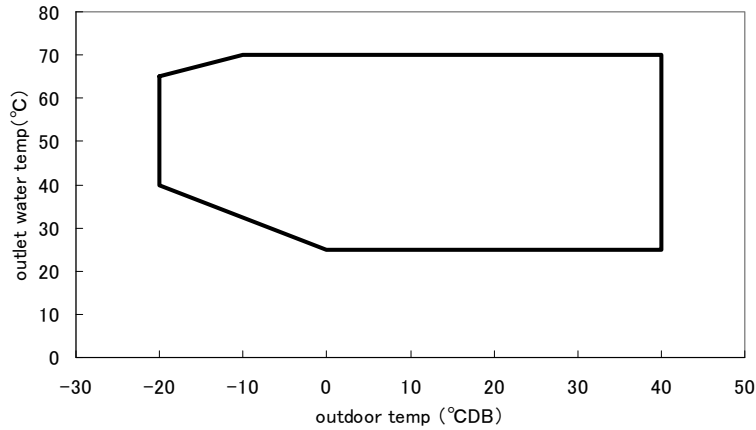

- Due to continuing improvements, specifications may be subject to change without notice.
- Do not use steel pipes as water pipes.
- Keep the water circulated at all times. Blow the water out of the pipes if the unit will not be used for an extended period of time.
- Do not use ground water or well water.
- Do not install the unit in an environment where the wet bulb temperature exceeds 32 °C.
- The water circuit must be a closed circuit.

Unit converter

Kcal = kW x 860
 BTU/h = kW x 3.412
 cfm = m³/min x 35.31
 Lb = kg/0.4536

This product is designed and intended for use in the residential,
commercial and light-industrial environment.

The product at hand is
based on the following
EU regulations:

- Low Voltage Directive 2006/95/EC
- Electromagnetic Compatibility Directive
2004/108/EC
- Pressure Equipment Directive 97/23/EC
- Machinery Directive 2006/42/EC

Please be sure to put the contact address/telephone number on
this manual before handing it to the customer.



HEAD OFFICE: TOKYO BLDG., 2-7-3, MARUNOUCHI, CHIYODA-KU, TOKYO 100-8310, JAPAN
Authorized representative in EU: MITSUBISHI ELECTRIC EUROPE B.V.

HARMAN HOUSE, 1 GEORGE STREET, UXBRIDGE, MIDDLESEX UB8 1QQ, U.K.