

## Water cooled screw chillers

WHS XE 098.1÷272.2

Cooling capacity from 343 to 957 kW

50Hz – Refrigerant: HFC 134a



McQuay is participating in the Eurovent Certification Programme. Product are as listed in the Eurovent Directory of Certified Products and on the web site [www.eurovent-certification.com](http://www.eurovent-certification.com)





# New water cooled screw chillers McQuay WHS XE

McQuay International introduces their newest water cooled screw chillers equipped with new single screw compressors.

McQuay water cooled WHS chillers equipped with 1 or 2 McQuay screw compressors are a new range of the unit using the Frame 4 single screw compressors. They are manufactured by McQuay to satisfy the requirements of the consultants and the end user. McQuay WHS units are designed to minimise energy costs while maximising the refrigeration capacities. Once again McQuay has developed a line of chillers unsurpassed in performance and quality that will meet the most stringent requirements of comfort cooling, ice storage and process applications.

McQuay's chiller design experience, combined with outstanding features makes the WHS chiller unmatched in the industry.

## Lower noise – higher flexibility

The McQuay original compressor design with a single screw and twin rotors allows a constant gas flow. This compression process completely eliminates gas pulsations. The oil injection also results in significant mechanical noise reduction.

The twin gas compressor discharge chambers are designed to act as attenuators, based on the harmonic wave principle with destructive interference, thus always resulting equal to zero. The extremely low noise compressor performance affords the use of WHS chiller for all applications.

The reduced number of vibrations produced from the WHS chillers offers a surprisingly quiet operation eliminating the noise transmission through the structure and the chilled water piping system.

## Infinitely variable capacity control

Cooling capacity control is infinitely variable by means of a capacity slide controlled by microprocessor system. Each unit has infinitely variable capacity control down to 12.5% (two compressors units), to 25% (one compressor unit). This modulation allows the compressor capacity to exactly match the building cooling load. The result is a decrease in chiller energy costs, particularly at the part-load conditions at which the chiller operates most of the time. In order to optimize control sequence, each compressor load (and unload) from 95 to 100 % of its capacity by one step.

## Unmatched serviceability

Field serviceability has not been sacrificed. Inspection covers allows visual inspection of the main screw and gaterotors. Suction valves allow easy isolation and field servicing of this unit.

## Outstanding reliability features

Full factory testing of all the units ensures a trouble free start-up. Extensive test makes certain that each safety and operating control is properly adjusted, and operates correctly.

# General characteristics

## Structure

The chiller is equipped with brackets directly installed on heat exchangers. The evaporator and the suction piping are appropriately insulated to prevent condensation. Unit is provided with lifting holes.

## Ecological HFC 134a refrigerant

McQuay has designed and optimized Stargate™ compressors to operate with HFC 134a, ecological refrigerant with zero ODP (Ozone Depletion Potential) and very low GWP (Global Warming Potential) that means low value of the "direct effect" in the formula of TEWI (Total Equivalent Warming Impact).

## Screw compressors

The newest Stargate™ single-screw compressor has a well balanced compression mechanism which cancels the screw rotor load in both the radial and axial directions. Inherent to the basic single-screw compressor design is the virtually load-free operation, that gives main bearing design life of 3-4 times greater than twin-screws, and eliminates expensive and complicated thrust balancing schemes. The two exactly opposed gaterotors create two exactly opposed compression cycles. Compression is made at the lower and upper parts of the screw rotor at the same time, thus cancelling the radial loads. Also, both ends of the screw rotor are subjected to suction pressure only, which cancels the axial loads and eliminates the huge thrust loads inherent in twin-screw compressors.

Oil injection is used for these compressors in order to get high COP at high condensing pressure. WHS units are provided with an high efficiency oil separator to maximise oil extraction.

Compressors have a infinitely variable capacity control down to 25% of its total capacity. This control is made by means of capacity slides controlled by microprocessors.

Standard start is star-delta type; Soft start type is available (as option) in order to have lower inrush current.

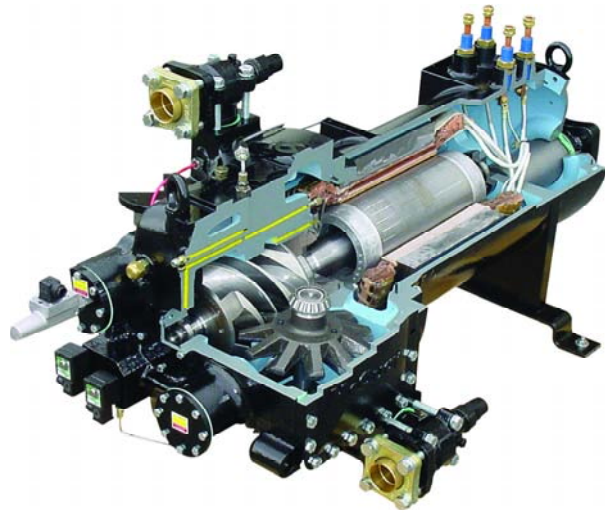

## Evaporator

The evaporator is a direct expansion type with refrigerant inside the copper tubes and water on the outside. The evaporators are manufactured with carbon steel shells, high efficiency copper tubes and polypropylene baffles. The copper tubes are roll expanded into carbon steel tube plates.

## Condensers

Condensers are shell and cleanable, through-tube type. Standard configuration is 2 passes. The unit has independent condensers, one per circuit. Each condenser has a carbon steel and seamless, integrally finned high efficiency copper tubes, roll expanded into heavy carbon steel tube sheets. Water heads are removable and include vent and drain plugs. Condensers come complete with liquid shut-off valve, spring loaded relief valve.

## Electronic expansion valve

The WHS water cooled chiller is equipped with the most advanced electronic expansion valve to achieve precise control of refrigerant mass flow. As today's system requires improved energy efficiency, tighter temperature control, wider range of operating conditions and incorporate new features like remote monitoring and diagnostics, the application of electronic expansion valves becomes mandatory. WHS's electronic expansion valve proposes features that makes it unique: short opening and closing time, high resolution, positive shut-off function to eliminate use of additional solenoid valve, highly linear flow capacity, continuous modulation of mass flow without stress in the refrigerant circuit and corrosion resistance stainless steel body.

## Electrical control panel

Power and control are located into two sections of the main panel that is manufactured to insure protection for all weather conditions.

The power panel is fitted with a interlocked door main isolator to prevent access while power supply is on. Electrical panel is IP43.

**Power section includes** - The power section includes contactors, all compressors fuses, and control circuit transformer. Additional space is provided for an easy installation of the various optional accessories provided to enhance the WHS units capabilities.

## Certifications

All the WHS units are CE marked (89/392). McQuay Italia obtained ISO 9001:2000.

## Water content in cooling circuits

The cooled water distribution circuits should have a minimum water content to avoid excessive compressors start and stop.

In fact, each time the compressor starts up, an excessive quantity of oil goes from the compressor sump and simultaneously there is a rise in the temperature of the compressor motor's stator due to the inrush current during the start-up. To prevent damage to the compressors, McQuay has envisaged the application of a device to limit frequent stops and restarts.

During the span of one hour there will be no more than 6 starts of the compressor. The plant side should therefore ensure that the overall water content allows a more constant functioning of the unit and consequently greater environmental comfort. The minimum installation water content envisaged should be calculated with a certain approximation using this simplified formula:

$$(1) \quad Q = 35,83 \times \frac{P \text{ (kW)}}{\Delta T \text{ (}^\circ\text{C)}} \times \frac{1}{N}$$

where:

Q = Minimum content of the plant expressed in litres

P = Cooling capacity of the plant expressed in kW

$\Delta T$  = Entering/leaving water temperature difference of the evaporator expressed in  $^\circ\text{C}$

N = Number of compressors.

For a more accurate determination of the quantity of water, it is advisable to contact the designer of the plant.

## MicroTech II C Plus controller

MicroTech II C Plus controller is installed as standard on all the units; it can be used to modify unit set points and check control parameters. A display illustrates the machine's operating status, programable values and setpoints e.g. temperatures, and pressures of fluids (water, refrigerant and air). Device controls maximise the McQuay chillers energy efficiency and reliability characteristics. It uses sophisticated software with predictive logic to select the most energy efficient combination of compressor, EEXV and condenser fan to keep stable operating conditions and maximise energy efficiency. The compressors are automatically rotated to ensure equal operating hours. MicroTech II protects critical components in response to external signals from its system sensors measuring: motor temperatures, refrigerant gas and oil pressures, correct phase sequence and evaporator.

### Control section - main features:

- Management of the compressor capacity slide and fans modulation according to the distributed multiprocessor logic system
- Chillers enabled to work in partial failure condition thanks to the distributed multiprocessor logic system
- Full routine operation at condition of:
  - High ambient temperature value
  - High thermal load
  - High evaporator entering water temperature (start-up)
- Display of evaporator entering/leaving water temperature
- Display of condensing-evaporating temperature and pressure, suction and discharge superheat for each circuit
- Leaving water cooled temperature regulation. Temperature tolerance=0,1  $^\circ\text{C}$
- Compressors and evaporator/condenser pumps hours counter
- Display of Status Safety Devices
- Start up numbers and compressors working hours equalization
- Excellent management of compressors load
- Fans management according to condensing pressure
- Automatic re-start in case of power supply interruption (adjustable)
- Soft Load
- Return Reset
- AOT Reset
- Setpoint Reset
- Demand limit or Current limit (optional)

### Safety for each refrigerant circuit

High pressure (pressure switch)

Low pressure (pressure switch)

Oil differential pressure switch  
 Compressor thermal  
 Condensation fan Magneto-thermal  
 High Discharge Temperature on the compressor  
 Phase Monitor  
 Star / Delta Transition Failed  
 Low Delta Pressure between Suction and Discharge  
 Low pressure ratio  
 High oil pressure drop  
 Low oil pressure

## System security

Phase monitor  
 Freeze protection

## Regulation type

Proportional + integral + derivative regulation on the evaporator output probe.

## Condensation

The condensation can be carried out according to temperature or pressure. The fans can be managed according to ON/OFF mode or with a 0/10 V modulating signal or both (SPEEDTROL).

## MicroTech II C Plus terminal

The MicroTech II C Plus terminal has following features:

- 4-lines by 20-character liquid crystal display back lighting
- Removable and remote key-pad
- Key-pad consisting of 15 keys “ clear language display ”
- Memory to protect the data
- General faults alarm relays
- 4-level password access to modify the setting
- Service report displaying all running hours and general conditions

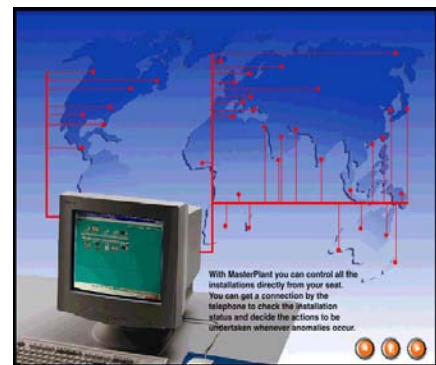

## MicroPlant™:

**Solution for: tele-maintenance and supervisory systems**

MicroTech II can be monitored locally or via modem by MicroPlant™ supervision program, that runs on PC systems under Windows '95 – '98.

## MicroPlant™ is the best solution:

- To centralise all the information in just one local and/or remote PC
- To check all the parameters for each unit connected
- Data logging of temperature - pressure
- Printouts of alarms, parameters and graphs
- To control several plants located in different geographical areas from a central station
- To manage the Service centers

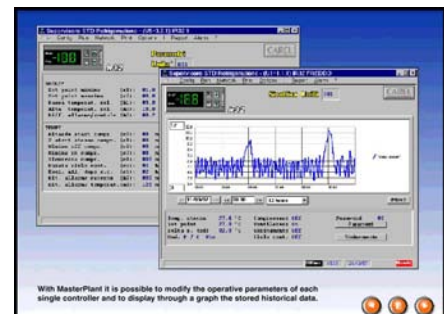

## MicroPlant™ allows:

- Visualization of all working conditions for each controller

- Visualization of their graphics
- Display, print-out of the actual alarms
- Connection between local and remote computer via telephone line (Modem)

## MicroTech II C Plus remote control

Compatibility with supervisory systems is becoming increasingly important in HVAC. MicroTech II C Plus allows easy interfacing with BMS (Building Management Systems), the external world that can be:

- Full compatible Siemens, Johnson;
- Every MODBUS compatible system; ( Satchwell, Honeywell )
- BacNet point to point, ECHELON FTT10. ( available on request )

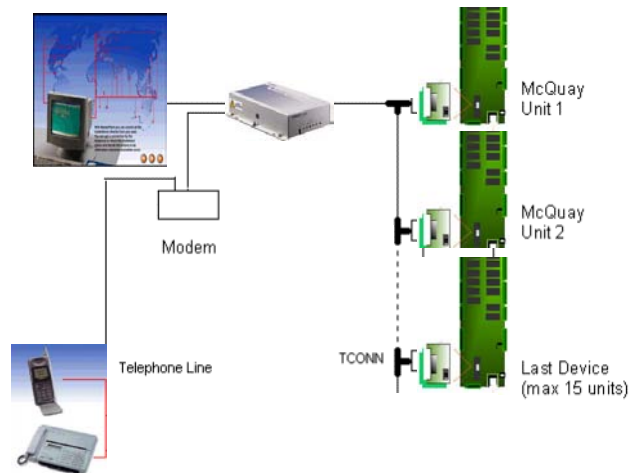

## Standard Accessories (furnished on basic unit)

**Star Delta Compressors starter** – For low inrush current and reduced starting torque.

**Phase monitor** – The phase monitor controls the voltage values on the supply line stopping the unit when the calibration threshold is reached ( $\pm 10\%$ ). This safety device is automatically reset.

**Evaporator connection water side Victaulic** – Hydraulic joint with gasket for an easy and quick water connection.

**Hour run meter** – Digital compressors hour run meter.

**General fault relay** – Contactor for the alarm warning.

**Alarm from external device** – Microprocessor is able to receive an alarm signal from an external device (pump etc.). User can decide if this alarm signal will stop or not the unit.

**Brine double set point version (CB)** – This accessory allows, with an external electric switch supplied by customer, a dual leaving glycol mixture temperature setpoints. The lower setpoint can go down to  $-8^{\circ}\text{C}$ .

## Options (on request)

**Compressor thermal overload relays** - Safety devices against compressor motor overloading in addition to the normal protection envisaged by the electrical windings.

**Ammeter and voltmeter** - Digital meters of unit drawn amperes and voltage values, installed on the electrical control panel.

**Condenser power factor correction** - Installed on the electrical control panel to ensure it conforms to the plant rules. (McQuay advises maximum 0,9).

**Flow switch** - Supplied separately to be wired and installed on the evaporator water piping (by the customer).

**Cu-Ni 90-10 condenser** – To work with sea water the heat exchangers are fitted with Cu-Ni tubes and special protection inside the end covers.

**Rubber type antivibration mounts** - Supplied separately, these are positioned under the base of the unit for "floor" installation.

**Sound proof cabinet** - Made of sheet metal and internally insulated, the cabinet is "integral kind" ( around the whole chiller, not only around the compressors ) to reach the best performance in noise reduction.

**Note:** to realize the baseframe consider that the dimensions of the sound proof cabinet are 300 mm longer, 300 mm wider and 200 mm higher than the standard unit.

**Suction line shut off valve** – Suction shut-off valve installed on the suction port of the compressor to facilitate maintenance operation.

**Witness tests** - The units are normally tested at the test bench prior to the shipment. On request, a second test can be carried out, at customer's presence, in accordance with the procedures indicated on the test form. (Not available for units with Glycol mixtures).

**Soft start** – Electronic starting device to reduce inrush current.

**20mm thicked evaporator insulation** – Useful in really heavy operating conditions.

**Under / Over voltage controller** - The device controls the voltage value and stops the chiller when this exceeds limits set by customer.

## Installation notes

### Warning

Installation and maintenance are to be performed only by qualified personnel who are familiar with local codes and regulations, and who are experienced with this type of equipment. Must be avoided the unit installation in places that could be considered dangerous for all the maintenance operations.

### Handling

The chiller is mounted on heavy wooden skids to protect the unit from accidental damage and to permit easy handling and moving. It is recommended that all moving and handling be performed with the skids under the unit when possible and that the skids not be removed until the unit is in the final location.

If the unit must be hoisted, it is necessary to lift the unit by attaching cables or chains at the lifting holes in the evaporator tube sheets. Spreader bars must be used to protect the control cabinet and the other areas of the chiller.

### Location

A levelled and sufficiently strong floor is required. If necessary, additional structural members should be provided to transfer the weight of the unit to the nearest beams.

Rubber-in-shear isolators can be furnished and field placed under each corner of the package. A rubber anti-skid pad should be used under isolators if hold-down bolts are not used.

Vibration isolator in all water piping connected to the chiller are recommended to avoid straining the piping and transmitting vibration and noise.



**Table 1 – Operating limits**

WHS 098.1÷272.2		HFC 134a
Max evaporator leaving water temperature	°C	15
Min evaporator leaving water temperature (without glycol)	°C	4
Min evaporator leaving water temperature (with glycol)	°C	-8
Min evaporator water ΔT	°C	4
Max evaporator water ΔT	°C	8
Max condenser leaving water temperature	°C	55

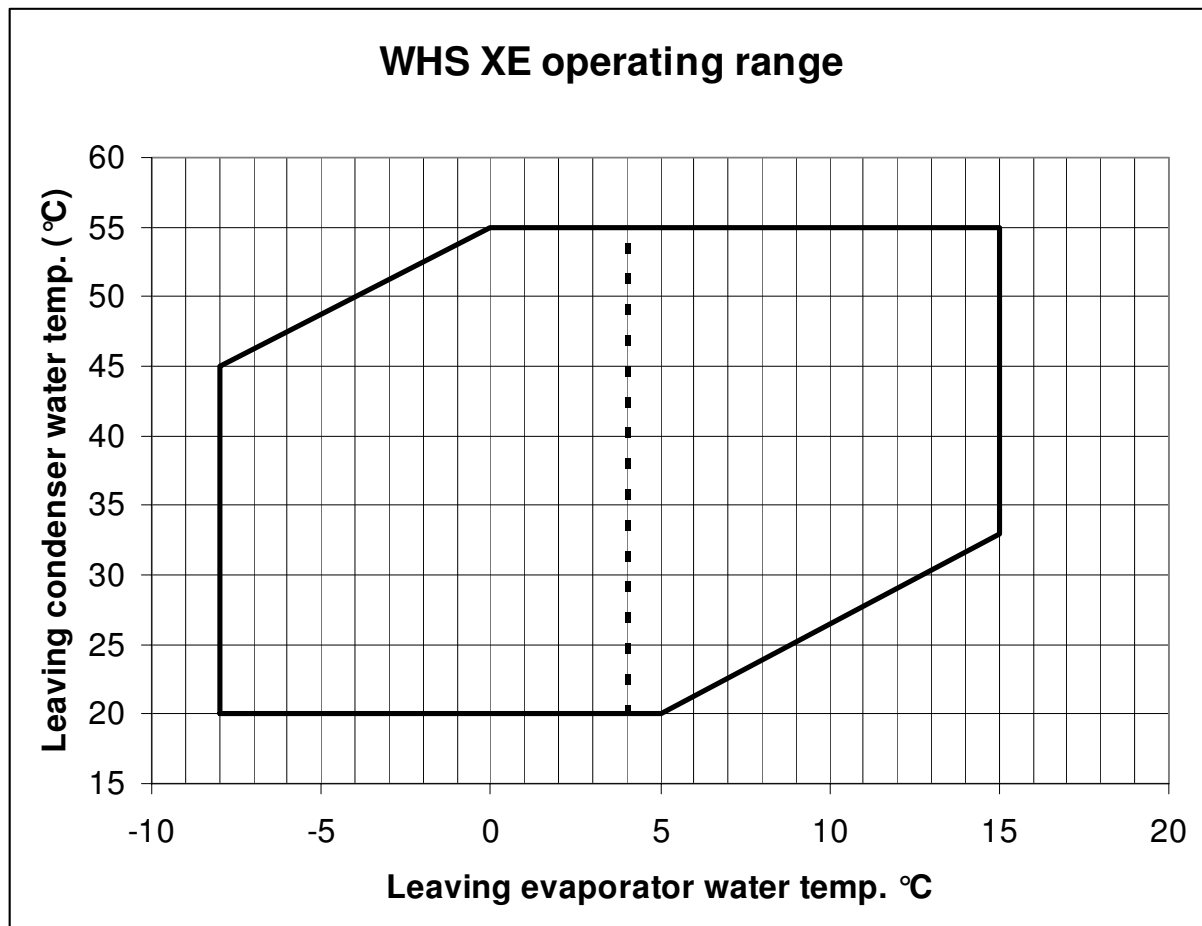

**Table 2 – Evaporator fouling factors**

Fouling factors m <sup>2</sup> °C / kW	Cooling capacity correction factor	Power input correction factor	COP correction factor
0,0176	1,000	1,000	1,000
0,0440	0,978	0,986	0,992
0,0880	0,957	0,974	0,983
0,1320	0,938	0,962	0,975

**Table 3 – Condenser fouling factors**

Fouling factors m <sup>2</sup> °C / kW	Cooling capacity correction factor	Power input correction factor	COP correction factor
0,0440	1,000	1,000	1,000
0,0880	0,990	1,018	0,973
0,1320	0,981	1,036	0,945

**Table 4 – Ethylene glycol and low ambient temperature correction factors**

Air ambient temperature °C	-3	-8	-15	-23	-35
% of ethylene glycol by weight	10	20	30	40	50
Cooling capacity correction factor	0,991	0,982	0,972	0,961	0,946
Power input correction factor	0,996	0,992	0,986	0,976	0,966
Flow rate correction factor	1,013	1,040	1,074	1,121	1,178
Water pressure drops correction factor	1,070	1,129	1,181	1,263	1,308

**Table 5 – Low temperature operation performance factors**

Ethylene glycol/water leaving temperature °C	2	0	-2	-4	-6	-8
Min. % of ethylene glycol	10	20	20	30	30	30
Cooling capacity correction factor	0,842	0,785	0,725	0,670	0,613	0,562
Power input compressors correction factor	0,95	0,94	0,92	0,89	0,87	0,84

# Nomenclature

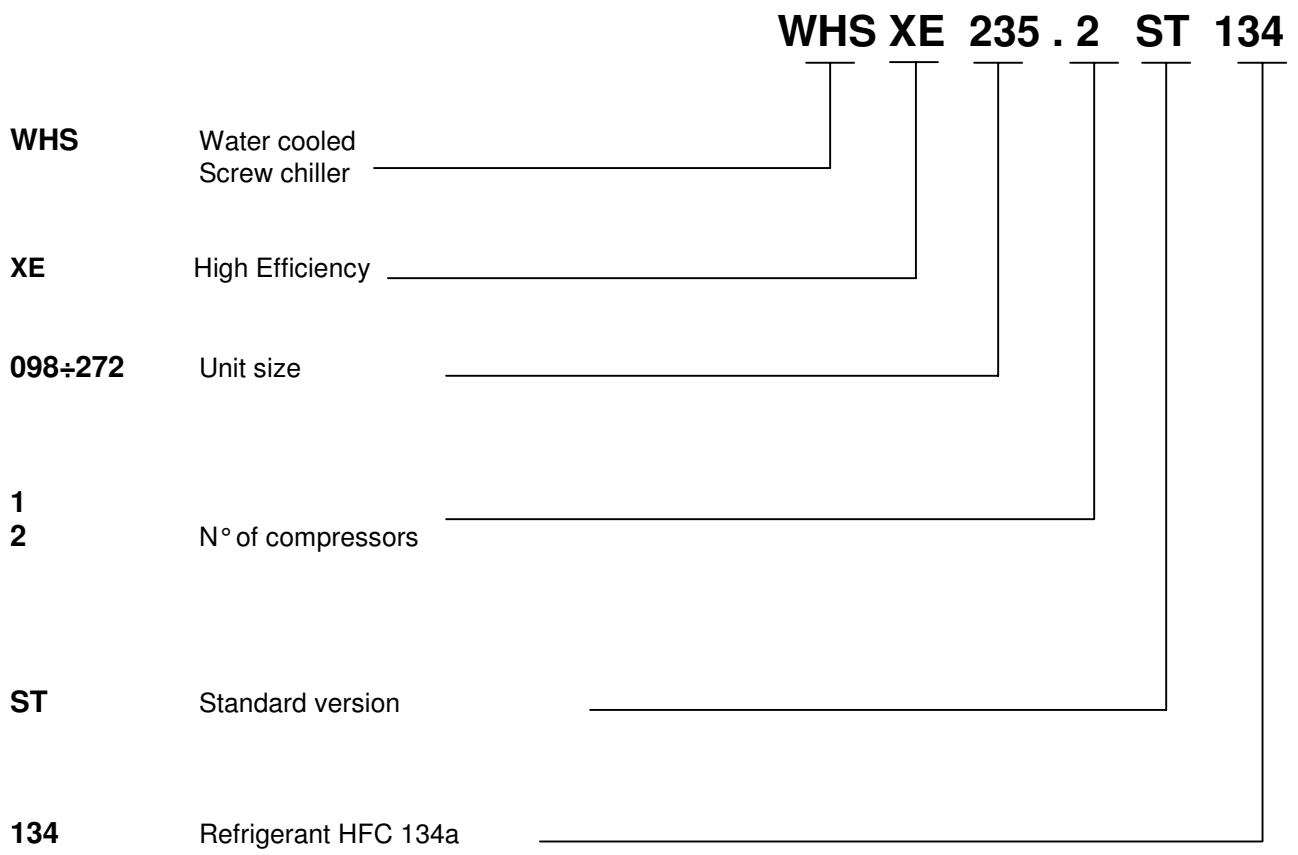

## Physical data WHS XE - HFC 134a

<b>“WHS” Unit size</b>		<b>098.1</b>	<b>118.1</b>	<b>138.1</b>	<b>196.2</b>
<b>Cooling capacity (1)</b>	<b>kW</b>	343,5	416,3	485,7	688,5
<b>Power input (1)</b>	<b>kW</b>	67,0	81,6	93,6	134,0
<b>COP</b>		5,13	5,10	5,19	5,14
<b>McQuay Stargate™ Screw compressor</b>	<b>No.</b>	1	1	1	2
<b>Refrigerant circuits</b>	<b>No.</b>	1	1	1	2
<b>Refrigerant charge HFC 134a</b>	<b>kg</b>	53	63	72	106
<b>Oil charge</b>	<b>l</b>	20	20	20	40
<b>Min % of capacity reduction</b>	<b>%</b>	25	25	25	12,5
<b>Evaporator</b>					
<b>Evaporators / water volume</b>	<b>No./l</b>	1/210	1/350	1/350	1/400
<b>Max operating pressure</b>	<b>bar</b>	10,5	10,5	10,5	10,5
<b>Condenser</b>					
<b>Condensers / water volume</b>	<b>No./l</b>	1/60	1/63	1/70	2/95
<b>Max operating pressure</b>	<b>bar</b>	10,5	10,5	10,5	10,5
<b>Weight and dimensions (cond. 2 passes <math>\Delta T</math> 4+8 °C)</b>					
<b>Standard unit shipping weight</b>	<b>kg</b>	1830	1855	1965	4215
<b>Standard unit operating weight</b>	<b>kg</b>	2100	2270	2385	4820
<b>Unit length</b>	<b>mm</b>	3695	3695	3695	4510
<b>Unit width</b>	<b>mm</b>	1050	1050	1050	1500
<b>Unit height</b>	<b>mm</b>	2018	2018	2070	2233

<b>“WHS” Unit size</b>		<b>218.2</b>	<b>235.2</b>	<b>254.2</b>	<b>272.2</b>
<b>Cooling capacity (1)</b>	<b>kW</b>	764,6	827,8	894,0	956,5
<b>Power input (1)</b>	<b>kW</b>	147,7	161,0	175,1	186,9
<b>COP</b>		5,18	5,14	5,11	5,12
<b>McQuay Stargate™ Screw compressor</b>	<b>No.</b>	2	2	2	2
<b>Refrigerant circuits</b>	<b>No.</b>	2	2	2	2
<b>Refrigerant charge HFC 134a</b>	<b>kg</b>	126	144	162	200
<b>Oil charge</b>	<b>l</b>	40	40	40	40
<b>Min % of capacity reduction</b>	<b>%</b>	12,5	12,5	12,5	12,5
<b>Evaporator</b>					
<b>Evaporators / water volume</b>	<b>No./l</b>	1/400	1/415	1/415	1/415
<b>Max operating pressure</b>	<b>bar</b>	10,5	10,5	10,5	10,5
<b>Condenser</b>					
<b>Condensers / water volume</b>	<b>No./l</b>	2/100	2/105	2/110	2/115
<b>Max operating pressure</b>	<b>bar</b>	10,5	10,5	10,5	10,5
<b>Weight and dimensions (cond. 2 passes <math>\Delta T</math> 4+8 °C)</b>					
<b>Standard unit shipping weight</b>	<b>kg</b>	4245	4275	4515	4720
<b>Standard unit operating weight</b>	<b>kg</b>	4840	4880	5140	5370
<b>Unit length</b>	<b>mm</b>	4510	4510	4510	4510
<b>Unit width</b>	<b>mm</b>	1500	1500	1500	1500
<b>Unit height</b>	<b>mm</b>	2233	2233	2233	2233

**Note:** (1) Nominal cooling capacity and power input are based on: 12/7 °C entering/leaving evaporator water temperature; 30/35 °C entering/leaving condenser water temperature. The power input is for compressor only.

## Electrical data WHS XE - HFC 134a

WHS unit size		098.1	118.1	138.1	196.2
Standard voltage (1)		400 V - 3f - 50 Hz			
Nominal unit current (2)	A	136	152	167	272
Max unit current (3)	A	183	215	243	366
Max unit inrush current star/delta (4)	A	593	593	593	695
Max unit current for wires sizing (5)	A	230	260	320	460

WHS unit size		218.2	235.2	254.2	272.2
Standard voltage (1)		400 V - 3f - 50 Hz			
Nominal unit current (2)	A	287	302	317	332
Max unit current (3)	A	397	427	458	485
Max unit inrush current star/delta (4)	A	706	710	718	722
Max unit current for wires sizing (5)	A	490	520	580	640

- Note:**
- (1) Allowed voltage tolerance  $\pm 10\%$ . Voltage unbalance between phases must be within  $\pm 3\%$ .
  - (2) Absorbed current referred to nominal condition: 12/7 °C entering/leaving evaporator water temperature; 30/35 °C entering/leaving condenser water temperature.
  - (3) Absorbed current referred to the following conditions: 14/9 °C entering/leaving evaporator water temperature; 50/55 °C entering/leaving condenser water temperature.
  - (4) StarDelta inrush current for the unique compressor (units 098.1÷138.1); absorbed current of compressor n°1 at 75% + inrush current of second compressor (units 196.2÷272.2).
  - (5) Compressor FLA (Full Load Ampere)

## Sound pressure level WHS XE

WHS Unit size	Sound pressure level at 1 m from the in free field ( rif. $2 \times 10^{-5}$ )								
	63 Hz	125 Hz	250 Hz	500 Hz	1000 Hz	2000 Hz	4000 Hz	8000 Hz	dBA
098.1	53,6	56,2	71,1	74,5	69,7	65,6	63,9	59,5	75,2
118.1	54,6	57,2	72,1	75,5	70,7	66,6	64,9	60,5	76,2
138.1	56,6	59,2	74,1	77,5	72,7	68,6	66,9	62,5	78,2
196.2	56,6	59,2	74,1	77,5	72,7	68,6	66,9	62,5	78,2
218.2	56,2	58,8	73,7	77,1	72,3	68,2	66,5	62,1	77,8
235.2	56,6	59,2	74,1	77,5	72,7	68,6	66,9	62,5	78,2
254.2	57,1	59,7	74,6	78,0	73,2	69,1	67,4	63,0	78,7
272.2	58,2	60,8	75,7	79,1	74,3	70,2	68,5	64,1	79,8

## Sound pressure level WHS XE with sound proof cabinet

WHS Unit size	Sound pressure level at 1 m from the in free field ( rif. $2 \times 10^{-5}$ )								
	63 Hz	125 Hz	250 Hz	500 Hz	1000 Hz	2000 Hz	4000 Hz	8000 Hz	dBA
098.1	48,6	49,5	61,6	63,3	56,8	52,1	51,0	46,6	63,2
118.1	49,6	50,5	62,6	64,3	57,8	53,1	52,0	47,6	64,2
138.1	51,6	52,5	64,6	66,3	59,8	55,1	54,0	49,6	66,2
196.2	51,6	52,5	64,6	66,3	59,8	55,1	54,0	49,6	66,2
218.2	51,2	52,1	64,2	65,9	59,4	54,7	53,6	49,2	65,8
235.2	51,6	52,5	64,6	66,3	59,8	55,1	54,0	49,6	66,2
254.2	52,1	53,0	65,1	66,8	60,3	55,6	54,5	50,1	66,7
272.2	53,2	54,1	66,2	67,9	61,4	56,7	55,6	51,2	67,8

**Note:** Average sound pressure level rated in accordance to ISO 3744, free field semispheric conditions.

## Sound pressure level correction factor for different distances

WHS Unit size	Distance (m)					
	1	5	10	15	20	25
098.1	0	8,4	13,4	16,5	18,8	20,7
118.1	0	8,4	13,4	16,5	18,8	20,7
138.1	0	8,4	13,4	16,5	18,8	20,7
196.2	0	8	12,9	15,9	18,2	20
218.2	0	8	12,9	15,9	18,2	20
235.2	0	8	12,9	15,9	18,2	20
254.2	0	8	12,9	15,9	18,2	20
272.2	0	8	12,9	15,9	18,2	20

**Note:** The values in table are in dB(A) and must be deduct to those refer at 1m in free field.

## Standard ratings WHS XE 098.1 ÷ 196.2

WHS unit size	Evaporator leaving water temp. (°C)	ENTERING CONDENSER WATER TEMPERATURE °C													
		20		25		30		35		40		45		50	
		Cool. cap. (kW)	Power input (kW)	Cool. cap. (kW)	Power input (kW)	Cool. cap. (kW)	Power input (kW)	Cool. cap. (kW)	Power input (kW)	Cool. cap. (kW)	Power input (kW)	Cool. cap. (kW)	Power input (kW)	Cool. cap. (kW)	Power input (kW)
WHS 098.1	4	336,8	51,2	323,7	58,3	309,9	66,0	295,3	74,4	280,2	83,8	264,7	94,1	248,7	105,5
	5	348,3	51,6	335,0	58,6	320,8	66,3	306,0	74,7	290,6	84,0	274,6	94,3	258,3	105,7
	6	360,1	51,9	346,5	59,0	332,0	66,6	316,9	75,0	301,1	84,3	284,8	94,6	268,1	105,9
	7	372,2	52,3	358,2	59,3	343,5	67,0	328,0	75,4	311,8	84,6	295,2	94,8	278,0	106,2
	8	384,4	52,6	370,2	59,7	355,1	67,3	339,3	75,7	322,8	84,9	305,7	95,1	288,2	106,4
	9	--	--	382,4	60,0	367,0	67,6	350,8	76,0	334,0	85,2	316,5	95,4	298,6	106,6
WHS 118.1	4	409,5	61,6	392,9	70,8	375,6	80,4	357,6	90,8	339,1	102,1	319,9	114,8	300,2	128,9
	5	423,6	61,9	406,6	71,2	388,9	80,8	370,5	91,1	351,5	102,4	331,9	115,0	311,7	129,0
	6	438,0	62,3	420,6	71,6	402,4	81,2	383,6	91,5	364,2	102,8	344,1	115,2	323,5	129,1
	7	452,6	62,6	434,8	72,0	416,3	81,6	397,0	91,9	377,1	103,1	356,6	115,4	335,6	129,2
	8	467,6	63,0	449,4	72,3	430,4	82,0	410,7	92,3	390,4	103,5	369,4	115,7	347,9	129,4
	9	--	--	464,2	72,7	444,8	82,5	424,7	92,7	403,9	103,8	382,5	116,0	360,5	129,6
WHS 138.1	4	478,8	71,7	458,8	81,8	438,4	92,3	417,5	103,8	396,0	116,6	374,0	131,2	351,3	148,1
	5	494,9	72,0	474,6	82,1	453,8	92,7	432,5	104,2	410,6	116,9	388,1	131,4	364,9	147,9
	6	511,4	72,2	490,8	82,5	469,6	93,2	447,9	104,7	425,5	117,3	402,5	131,6	378,7	147,9
	7	528,3	72,3	507,3	82,9	485,7	93,6	463,6	105,1	440,7	117,7	417,2	131,9	392,9	147,9
	8	545,5	72,5	524,2	83,2	502,2	94,1	479,6	105,6	456,3	118,2	432,2	132,2	407,3	148,1
	9	--	--	541,4	83,5	519,0	94,5	495,9	106,1	472,1	118,7	447,5	132,6	422,1	148,3
WHS 196.2	4	675,1	102,4	648,8	116,6	621,0	132,0	591,9	148,9	561,6	167,6	530,3	188,2	498,3	211,1
	5	698,3	103,2	671,4	117,3	643,0	132,6	613,3	149,5	582,3	168,1	550,3	188,7	517,5	211,5
	6	722,0	103,9	694,6	118,0	665,6	133,3	635,1	150,1	603,4	168,7	570,7	189,2	537,1	211,9
	7	746,2	104,6	718,2	118,7	688,5	134,0	657,4	150,8	625,0	169,2	591,5	189,7	557,1	212,3
	8	770,8	105,3	742,2	119,4	712,0	134,6	680,2	151,4	647,0	169,8	612,8	190,2	577,5	212,8
	9	--	--	766,8	120,0	735,8	135,3	703,3	152,0	669,5	170,4	634,4	190,8	598,4	213,3

**Note:** (1) Nominal cooling capacity and power input are based on  $\Delta T=5^{\circ}\text{C}$  entering/leaving condenser water temperature; evaporator fouling factor= $0,0176\text{ m}^2\text{ }^{\circ}\text{C}/\text{kW}$ ; condenser fouling factor= $0,0440\text{ m}^2\text{ }^{\circ}\text{C}/\text{kW}$ .

## Standard ratings WHS XE 218.2 ÷ 272.2

WHS unit size	Evaporator leaving water temp. (°C)	ENTERING CONDENSER WATER TEMPERATURE °C													
		20		25		30		35		40		45		50	
		Cool. cap. (kW)	Power input (kW)	Cool. cap. (kW)	Power input (kW)	Cool. cap. (kW)	Power input (kW)	Cool. cap. (kW)	Power input (kW)	Cool. cap. (kW)	Power input (kW)	Cool. cap. (kW)	Power input (kW)	Cool. cap. (kW)	Power input (kW)
WHS 218.2	4	750,7	112,0	720,9	128,2	689,6	145,5	657,0	164,2	623,1	184,8	588,3	207,6	552,4	233,1
	5	776,6	112,7	746,1	128,9	714,1	146,2	680,7	164,9	646,1	185,3	610,4	208,0	573,7	233,3
	6	803,0	113,4	771,8	129,7	739,1	146,9	704,9	165,6	669,5	186,0	632,9	208,5	595,4	233,6
	7	829,9	114,1	798,0	130,4	764,6	147,7	729,6	166,3	693,4	186,6	656,0	209,1	617,6	234,0
	8	857,4	114,8	824,8	131,1	790,6	148,4	754,9	167,0	717,9	187,3	679,6	209,6	640,3	234,4
	9	--	--	852,1	131,8	817,1	149,1	780,6	167,7	742,8	187,9	703,7	210,2	663,5	234,9
WHS 235.2	4	814,0	121,2	781,6	139,5	747,7	158,6	712,6	179,2	676,1	201,7	638,5	226,8	599,9	254,9
	5	841,7	121,8	808,5	140,2	773,9	159,4	737,9	179,9	700,6	202,3	662,2	227,2	622,6	255,0
	6	870,0	122,5	836,0	141,0	800,5	160,2	763,7	180,7	725,7	203,0	686,4	227,6	645,9	255,2
	7	898,8	123,2	864,0	141,8	827,8	161,0	790,2	181,5	751,2	203,7	711,1	228,2	669,7	255,5
	8	928,2	123,8	892,6	142,5	855,6	161,8	817,2	182,3	777,4	204,4	736,3	228,7	694,1	255,8
	9	--	--	921,9	143,3	884,0	162,7	844,7	183,1	804,1	205,2	762,1	229,3	719,0	256,2
WHS 254.2	4	880,6	133,2	844,5	152,4	807,3	172,5	769,0	194,4	729,5	218,6	688,9	245,9	647,1	277,1
	5	910,3	133,8	873,5	153,1	835,6	173,4	796,5	195,2	756,1	219,2	714,6	246,3	671,9	277,0
	6	940,6	134,3	903,2	153,9	864,5	174,2	824,5	196,0	783,3	219,9	740,9	246,7	697,2	277,0
	7	971,6	134,9	933,4	154,6	894,0	175,1	853,2	196,8	811,1	220,6	767,7	247,2	723,0	277,1
	8	1003,3	135,3	964,3	155,3	924,1	175,9	882,4	197,7	839,5	221,4	795,1	247,8	749,4	277,4
	9	--	--	995,9	156,0	954,8	176,7	912,3	198,6	868,4	222,3	823,1	248,4	776,4	277,8
WHS 272.2	4	943,1	143,2	904,2	163,2	864,4	184,2	823,6	207,2	781,7	233,0	738,7	262,4	694,5	296,2
	5	974,5	143,7	934,9	164,0	894,4	185,1	852,9	208,1	810,2	233,6	766,2	262,6	720,9	295,9
	6	1006,5	144,2	966,4	164,7	925,1	186,0	882,8	208,9	839,2	234,3	794,3	263,0	748,0	295,8
	7	1039,3	144,5	998,5	165,4	956,5	186,9	913,3	209,8	868,9	235,1	823,0	263,5	775,7	295,8
	8	1072,8	144,8	1031,2	166,0	988,5	187,8	944,5	210,8	899,2	236,0	852,3	264,1	803,9	296,0
	9	--	--	1064,7	166,6	1021,2	188,6	976,3	211,7	930,0	236,9	882,1	264,8	832,6	296,4

**Note:** (1) Nominal cooling capacity and power input are based on  $\Delta T=5^{\circ}\text{C}$  entering/leaving condenser water temperature; evaporator fouling factor= $0,0176\text{ m}^2\text{ }^{\circ}\text{C}/\text{kW}$ ; condenser fouling factor= $0,0440\text{ m}^2\text{ }^{\circ}\text{C}/\text{kW}$ .



# Evaporator pressure drop

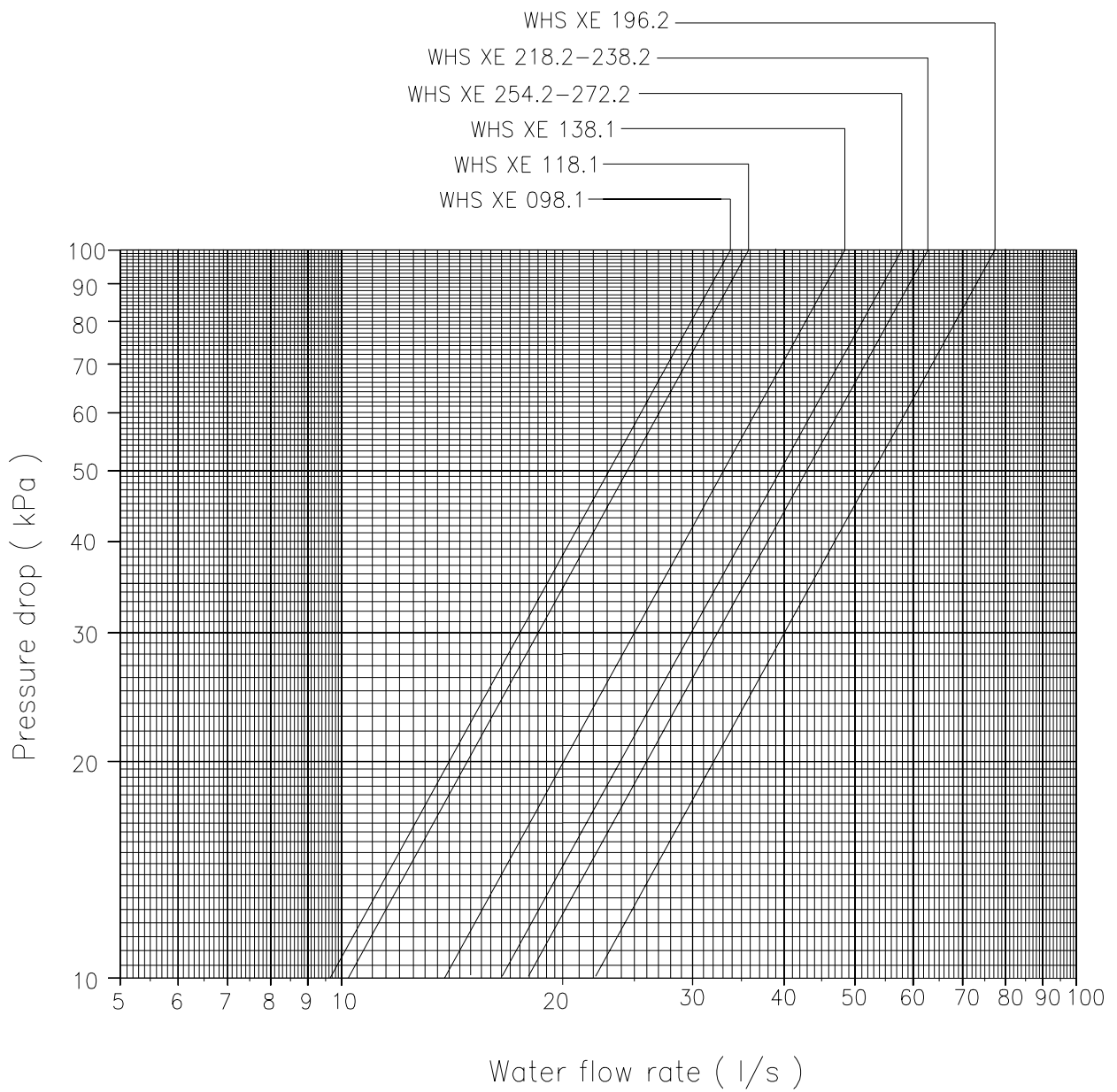

**Note:** in case of pressure drop higher than 100 kPa, it is necessary to contact the factory.

## Condenser (2 passes) pressure drop

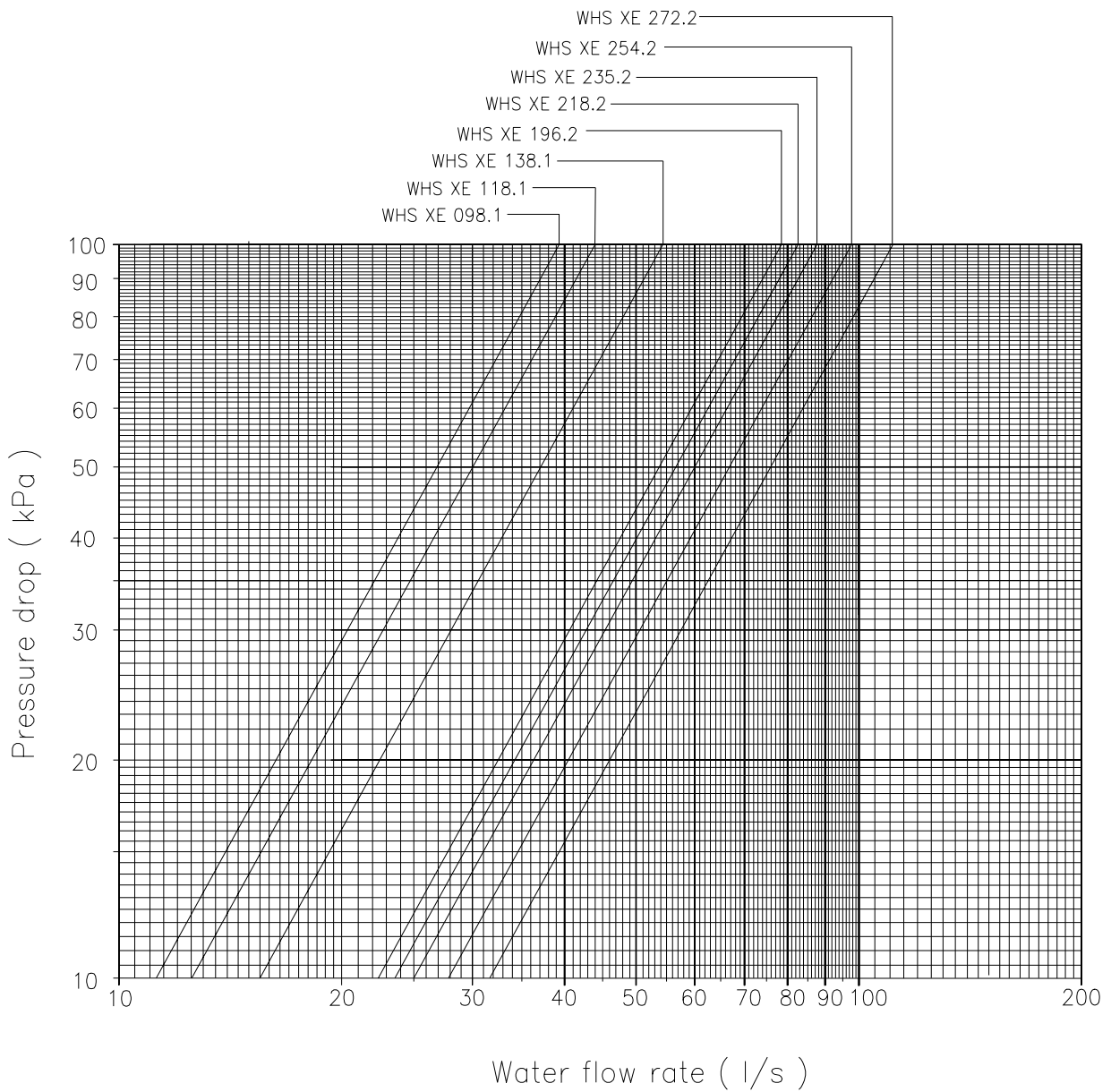

**Note:** in case of pressure drop higher than 100 kPa, it is necessary to contact the factory.

**Note:** in case of pressure drop less than 10 kPa it is necessary install a 4 passes condenser

## Condenser (4 passes) pressure drop

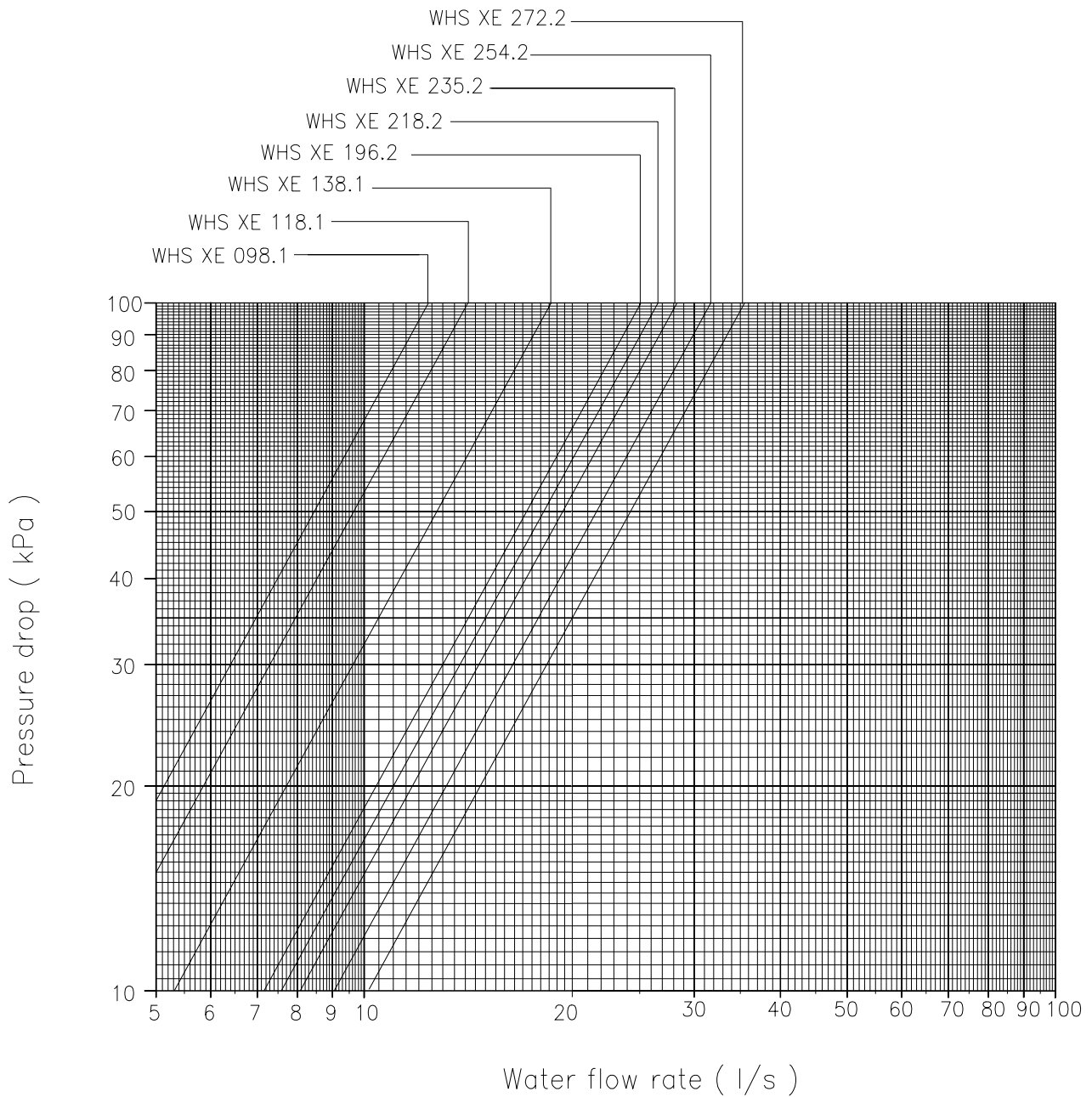

**Note:** in case of pressure drop higher than 100 kPa, it is necessary to contact the factory.

## Dimensions WHS XE 098.1 ÷ 138.1

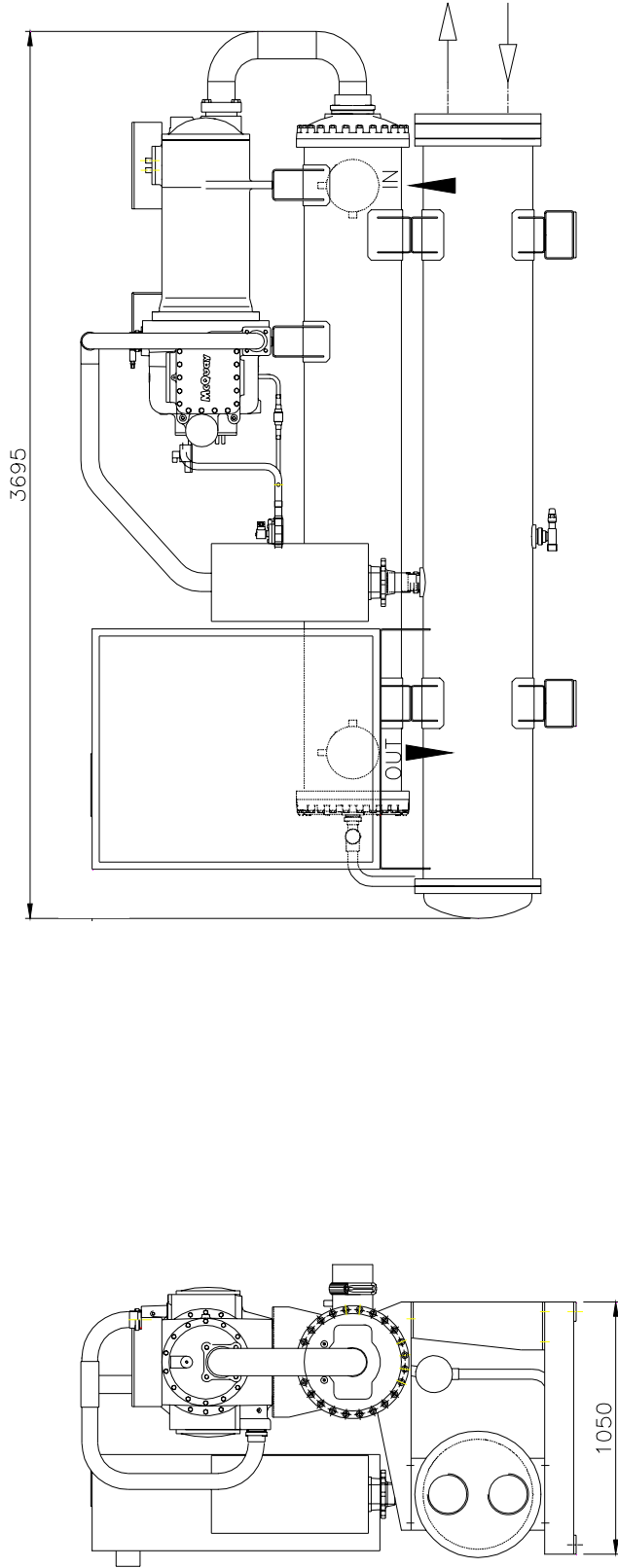

# Dimensions WHS XE 196.2 ÷ 272.2

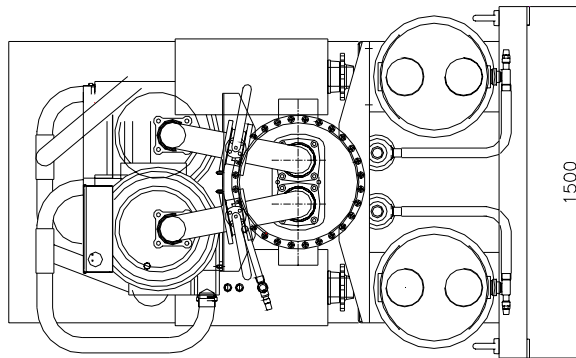
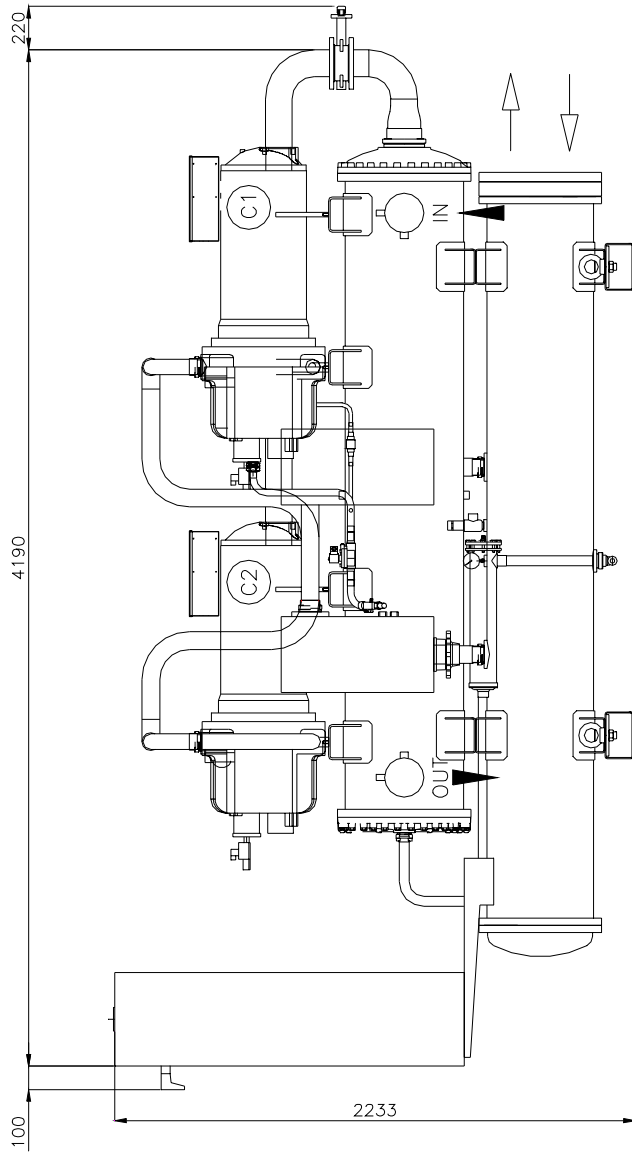

## WHS HF Frame 4 - Technical specifications

To supply and install, where specified in the project n ..... unit(s) water cooled chiller with cooling capacity of ..... kW, to cool ..... l/sec. of water from ..... °C to ....., condenser entering water temperature ....°C, condenser leaving water temperature ....°C. The unit should work with electricity at ..... V, 3ph, 50Hz. The electrical power absorbed should not exceed ..... kW. The units COP will be at least ..... at the working conditions of the project. Part load COP will be at least ..... at the working conditions of the project. For the units with 1, or 2 compressors the chillers will have (1), or (2) independent refrigerant circuits, and the respective electronic microprocessor will allow the starting of the compressors. Each chiller will be factory assembled on a robust baseframe. The unit will be tested at full load in the factory at the nominal working conditions and water temperatures. Before shipment a full test will be held to avoid any losses, and the units will be filled with oil and refrigerant.

**Refrigerant** - only HFC 134a will be accepted.

**Noise level and vibrations** – Sound pressure level at 1 meter distance in free field shall not exceed .....dBA  
Vibration level should not exceed 2 mm/s.

Units will have the following components:

**Compressors** - The compressor should be single screw type with one main screw rotor that meshes with two diametrically opposed gaterotors. The two exactly opposed gaterotors create two exactly opposed compression cycles which results in balanced forces acting on the compressor. The gaterotors should be constructed of a carbon impregnated engineered composite material. The gaterotor supports will be constructed of cast iron. The semi-hermetic compressor should be gas-cooled.

Oil injection shall be used for this compressor in order to get high COP at high condensing pressure. The unit should be provided with an oil separator and it will be the high efficiency, augmented gas impingement type to maximise oil extraction.

**Evaporator** - The units will be supplied with one direct expansion evaporator with refrigerant inside the tubes and water outside (shell side) with carbon steel tube sheets, with straight copper tubes that are spirally wound internally for higher efficiencies, expanded on the tube plates. The external shell, will be linked with an electrical heater to prevent freezing to - 28 C ambient temperature, commanded by a thermostat and will be covered with a closed cell insulation material. Each evaporator will have 1, or 2 refrigerant circuits one for each compressor. Each evaporator is manufactured in accordance to PED approval.

**Condensers** - Condensers will be shell and cleanable, through-tube type. The unit will have one condensers per circuit. Each condenser shall have a carbon steel and seamless, integrally finned high efficiency copper tubes, roll expanded into heavy carbon steel tube sheets. Water heads shall be removable and include vent and drain plugs. Condensers will come complete with liquid shut-off valve, spring loaded relief valve.

**Electronic expansion valve** - Each refrigerant circuit will be equipped with all the necessary components in order to ensure the workings and service (dehydration filter, liquid sight glass, shut-off valve, load connection, pressure switch etc.) and an electronic expansion valve that allows a simple control system that quickly interacts at load variations. This valve combines two functions: liquid solenoid and electronic expansion valve. It is managed directly by a microprocessor.

**Control panel** - Field power connection, control interlock terminals, and unit control system should be centrally located in an electric panel (IP 43). Power and starting controls should be separate from safety and operating controls in different compartments of the same panel. Starting will be star/delta type. Power and starting controls should include fuses and contactors for each compressor winding. Operating and safety controls should include energy saving control; emergency stop switch; overload protection for compressor motor; high and low pressure cut-out switch (for each refrigerant circuit); anti-freeze thermostat; compressor lead-lag switch (on 2 compressor units only); cut-out switch for each compressor; operating hour meter (for each compressor).

All of the information regarding the unit will be reported on a display and with the internal built-in calendar and clock that will switch the unit ON/OFF during day time all year long.

**Regulation of cooling capacity** - Each unit will have a microprocessor for the control and operation of the unit that should have a infinitely variable capacity control down to 12,5% (two compressors), to 25% (one compressor) of the cooling capacity.

**Refrigerant piping** - Refrigerant circuit should include a factory insulated suction line, manual liquid line shut-off valve with charging connection, refrigerant filter drier with replaceable core, sensor indicator, electronic expansion valve and relief valve.



We reserve the right to make changes in design and construction at any time without notice, thus the cover picture is not binding.

McQuay partecipa al programma di  
Certificazione Eurovent.  
I prodotti interessati figurano nella Guida  
Eurovent dei Prodotti Certificati.



McQuay is participating in the Eurovent  
Certification Programme  
Product are as listed in the Eurovent  
Directory of Certified Products

**McQuay**<sup>®</sup>  
International

McQuay Italia S.P.A.

S.S. Nettunense, km 12+300 – 00040 Cecchina (Roma) Italia – Tel. (06) 937311 – Fax (06) 9374014 – E-mail: [info@mcquayeuropa.com](mailto:info@mcquayeuropa.com)  
[www.mcquayeuropa.com](http://www.mcquayeuropa.com)