

## Water cooled screw chillers

WHS 095.1 ÷ 539.4

Cooling capacity from 334 to 1893 kW

50Hz – Refrigerant: HFC 134a



# New water cooled screw chillers McQuay WHS

McQuay International introduces their newest water cooled screw chillers equipped with new single screw compressors.

McQuay water cooled WHS chillers equipped with 1, 2, 3 and 4 McQuay screw compressors are a new range of the unit using the StarGate™ Frame 4 single screw compressors. They are manufactured by McQuay to satisfy the requirements of the consultants and the end user. McQuay WHS units are designed to minimise energy costs while maximising the refrigeration capacities. Once again McQuay has developed a line of chillers unsurpassed in performance and quality that will meet the most stringent requirements of comfort cooling, ice storage and process applications.

McQuay's chiller design experience, combined with outstanding features makes the WHS chiller unmatched in the industry.

## Lower noise – higher flexibility

The McQuay original compressor design with a single screw and twin rotors allows a constant gas flow. This compression process completely eliminates gas pulsations. The oil injection also results in significant mechanical noise reduction.

The twin gas compressor discharge chambers are designed to act as attenuators, based on the harmonic wave principle with destructive interference, thus always resulting equal to zero. The extremely low noise compressor performance affords the use of WHS chiller for all applications.

The reduced number of vibrations produced from the WHS chillers offers a surprisingly quiet operation eliminating the noise transmission through the structure and the chilled water piping system.

## Infinitely variable capacity control

Cooling capacity control is infinitely variable by means of a capacity slide controlled by microprocessor system. Each unit has infinitely variable capacity control down to 6.25% (four compressors units), to 8.3% (three compressors units), to 12.5% (two compressors units), to 25% (one compressor units). This modulation allows the compressor capacity to exactly match the building cooling load. The result is a decrease in chiller energy costs, particularly at the part-load conditions at which the chiller operates most of the time. In order to optimize control sequence, each compressor load (and unload) from 95 to 100 % of its capacity by one step.

## Unmatched serviceability

Field serviceability has not been sacrificed. Inspection covers allows visual inspection of the main screw and gaterotors. Suction valves allow easy isolation and field servicing of this unit.

## Outstanding reliability features

Full factory testing of all the units ensures a trouble free start-up. Extensive test makes certain that each safety and operating control is properly adjusted, and operates correctly.

# General characteristics

## Structure

The chiller is equipped with brackets directly installed on heat exchangers. The evaporator and the suction piping are appropriately insulated to prevent condensation. Unit is provided with lifting holes.

## Ecological HFC 134a refrigerant

As the HCFC phase out will occur more quickly than currently legislated, the designers, owners and operators should only evaluate equipment using chlorine free refrigerants. McQuay has designed and optimized new Stargate™ compressors to operate with HFC 134a, ecological refrigerant with zero ODP (Ozone Depletion Potential) and very low GWP (Global Warming Potential) that means low value of the "direct effect" in the formula of TEWI (Total Equivalent Warming Impact).

## Screw compressors

The newest Stargate™ single-screw compressor has a well balanced compression mechanism which cancels the screw rotor load in both the radial and axial directions. Inherent to the basic single-screw compressor design is the virtually load-free operation, that gives main bearing design life of 3-4 times greater than twin-screws, and eliminates expensive and complicated thrust balancing schemes. The two exactly opposed gaterotors create two

exactly opposed compression cycles. Compression is made at the lower and upper parts of the screw rotor at the same time, thus cancelling the radial loads. Also, both ends of the screw rotor are subjected to suction pressure only, which cancels the axial loads and eliminates the huge thrust loads inherent in twin-screw compressors. Oil injection is used for these compressors in order to get high COP at high condensing pressure. WHS units are provided with an high efficiency oil separator to maximise oil extraction. Compressors have a infinitely variable capacity control down to 25% of its total capacity. This control is made by means of capacity slides controlled by microprocessors. Standard start is star-delta type; Soft start type is available (as option) in order to have lower inrush current.

## Evaporator

The evaporator is a direct expansion type with refrigerant inside the copper tubes and water on the outside. The evaporators are manufactured with carbon steel shells, high efficiency copper tubes and polypropylene baffles. The copper tubes are roll expanded into carbon steel tube plates.

## Condensers

Condensers are shell and cleanable, through-tube type. The unit has independent condensers, one per circuit. Each condenser has a carbon steel and seamless, integrally finned high efficiency copper tubes, roll expanded into heavy carbon steel tube sheets. Water heads are removable and include vent and drain plugs. Condensers come complete with liquid shut-off valve, spring loaded relief valve.

**Note: The units are furnished with 1 pass condensers as standard (water entering a side and water leaving the opposite side of the heat exchanger).**

**On request the chillers will be equipped with:**

- **condensers one pass with entering and leaving water on the same side of the heat exchanger through a steel pipe bringing back the leaving water flow.**
- **condensers two passes “4÷8 °C water  $\Delta T$ ”. In this case total heat recovery is not available.**
- **condensers two passes “8÷15 °C water  $\Delta T$ ”.**

## Electronic expansion valve

The WHS water cooled chiller is equipped with the most advanced electronic expansion valve to achieve precise control of refrigerant mass flow. As today's system requires improved energy efficiency, tighter temperature control, wider range of operating conditions and incorporate new features like remote monitoring and diagnostics, the application of electronic expansion valves becomes mandatory. WHS's electronic expansion valve proposes features that makes it unique: short opening and closing time, high resolution, positive shut-off function to eliminate use of additional solenoid valve, highly linear flow capacity, continuous modulation of mass flow without stress in the refrigerant circuit and corrosion resistance stainless steel body.

## Electrical control panel

Power and control are located into two sections of the main panel that is manufactured to insure protection for all weather conditions.

The power panel is fitted with a interlocked door main isolator to prevent access while power supply is on. Electrical panel is IP54.

**Power section includes** - The power section includes contactors, all compressors fuses, and control circuit transformer. Additional space is provided for an easy installation of the various optional accessories provided to enhance the WHS units capabilities.

## Certifications

All the WHS units are CE marked (89/392). McQuay Italia obtained ISO 9001 certification in 1997.

## Available versions

The WHS units are available in 3 versions:

**WHS ST** - standard.

**WHS LR** – special execution without water condensers but equipped with liquid receivers, one per refrigerant circuit and copper connection to be welded on the remote condenser. The unit version is specially designed for remote air condenser application or evaporating gas condensers.

**WHS ME** – special execution without condensers. Similar to the LR version but without the liquid receiver that must be included in the plant circuit.

## Water content in cooling circuits

The cooled water distribution circuits should have a minimum water content to avoid excessive compressors start and stop.

In fact, each time the compressor starts up, an excessive quantity of oil goes from the compressor's sump and simultaneously there is a rise in the temperature of the compressor motor's stator due to the inrush current during the start-up. To prevent damage to the compressors, McQuay has envisaged the application of a device to limit frequent stops and restarts.

During the span of one hour there will be no more than 6 starts of the compressor. The plant side should therefore ensure that the overall water content allows a more constant functioning of the unit and consequently greater environmental comfort. The minimum installation water content envisaged should be calculated with a certain approximation using this formula:

$$(1) \quad Q = \frac{P \times \rho}{25}$$

where:

Q = minimum content of the plant expressed in litres

P = cooling capacity of the plant expressed in W

$\rho$  = minimum unloading capacity percentage

For a more accurate determination of the quantity of water, it is advisable to contact the designer of the plant.

## MicroTech II controller

MicroTech II device is installed as standard on all the units; it can be used to alter unit set points and control commands. A display illustrates the machine's operating status and programmable parameters (setpoints) e.g. temperatures and pressures of fluids (water, refrigerant). Device controls maximise the McQuay chillers energy efficiency and reliability characteristics. It uses sophisticated software with predictive logic to select the most energy efficient combination of compressor, EEV to maintain stable operating conditions and maximise energy efficiency. The compressors are automatically rotated to ensure equal operating hours. Microprocessor device protects critical components in response to external signals from its system sensors measuring: motor temperatures, refrigerant gas and oil pressures, electrical supply and evaporator.

### Control section - main features:

- Management of the compressor capacity slide according to the distributed multiprocessor logic system
- Chillers enabled to work in partial failure condition thanks to the distributed multiprocessor logic system
- Full routine operation at condition of:
  - High thermal load
  - High evaporator entering water temperature (start-up)
- Display of evaporator entering/leaving water temperature
- Display of condensing-evaporating temperature and pressure, superheat temperature for each circuit
- Leaving water cooled temperature regulation (also available entering water regulation). Temperature tolerance=0,2°C
- Compressors and evaporator/condenser pumps hours counter
- Display of Status Safety Devices
- Start up numbers and compressors working hours equalization
- Excellent management of compressors load
- Automatic re-start in case of power supply interruption

### Safety for each refrigerant circuit

High pressure (pressure switch)

Low pressure (pressure switch)

Oil differential pressure switch

Compressor thermal  
High Discharge Temperature on the compressor  
Phase Monitor  
Star / Delta Transition Failed  
Low Delta Pressure between Suction and Discharge

## System security

A serious alarm input (stops the unit)  
A flow controller input (stops the unit)  
A pump thermal input (stops the unit)  
Remote on/off input without alarm signaling

## Regulation type

Proportional or proportional + integral regulation on the evaporator input probe.

## MicroTech II terminal

The MicroTech II terminal has following features:

- 4-lines by 20-character liquid crystal display
- Removable and remote key-pad
- Key-pad consisting of 15 keys “ clear language display ”
- Memory to protect the data
- General faults alarm led
- 4-level password access to modify the setting
- Service report displaying all working hours and general conditions

## MicroPlant™:

**Solution for: tele-maintenance and supervisory systems**

MicroTech II can be monitored locally or via modem by MicroPlant supervision program, that runs on PC systems under Windows '95 – '98 – 2000.

## MicroPlant is the best solution:

- To centralise all the information in just one local and/or remote PC
- To check all the parameters for each unit connected
- To be informed immediately and automatically of any alarm situation via modem - fax - voice message - printouts
- Data logging of temperature - humidity - pressure
- Automatic printouts of alarms, parameters and graphs
- To control several plants located in different geographical areas from a central station
- To manage the Service centers



## MicroPlant allows:

- Visualization and modification of all the parameters for each controller
- Protection of the main parameters against incidental modifications (different levels of passwords)
- Memorization of the detected values and visualization of their graphics
- Display, print-out and chronological memorization of the detected alarms
- Connection between local and remote computer via telephone line (Modem)



## MicroTech II remote control

Compatibility with supervisory systems is becoming increasingly important in HVAC. MicroTech II allows easy interfacing with BMS (Building Management Systems), the external world that can be:

Landis & Staefa, Siemens, Johnson, Honeywell, Satchwell, Trend.

McQuay Chiller System Controller (CSC) is available as option.

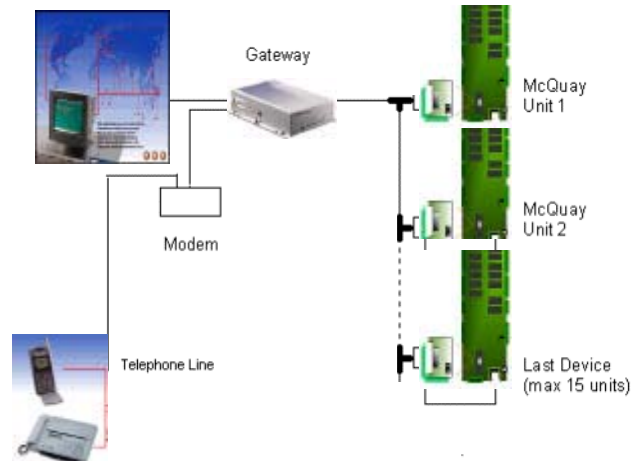

## Standard Accessories (furnished on basic unit)

**Star Delta Compressors starter** – For low inrush current and reduced starting torque.

**Phase monitor** – The phase monitor controls the voltage values on the supply line stopping the unit when the calibration threshold is reached ( $\pm 10\%$ ). This safety device is automatically reset.

**Evaporator connection water side Victaulic** – Hydraulic joint with gasket for an easy and quick water connection.

**Hour run meter** – Digital compressors hour run meter.

**General fault contactor** – Contactor for the alarm warning.

## Options (on request)

**100% total heat recovery (R)** – Produced with tube bundle placed in a single shell with the water condensers. Heat exchangers heads are provided with 2 connections for entering/leaving heat recovery water and 2 separate connections for condensing water.

**Partial heat recovery (D)** – Produced with plate to plate heat exchangers installed on discharge side of compressor hot gas. These allow hot water to be produced up to a maximum temperature of  $+ 50^{\circ}\text{C}$ .

**Brine double set point version (CB)** - Dual leaving glycol mixture temperature setpoints. The lower setpoint can go down to  $-8^{\circ}\text{C}$ .

**Compressor thermal overload relays** - Safety devices against compressor motor overloading in addition to the normal protection envisaged by the electrical windings.

**Ammeter and voltmeter** - Digital meters of unit drawn amperes and voltage values, installed on the electrical control panel.

**Condenser power factor correction** - Installed on the electrical control panel to ensure it conforms to the plant rules. (McQuay advises maximum 0,9).

**Flow switch** - Supplied separately to be wired and installed on the evaporator water piping (by the customer).

**Suction line shut off valve** – Suction shut-off valve installed on the suction port of the compressor to facilitate maintenance operation.

**Cu-Ni 90-10 condenser** – To work with sea water the heat exchangers are fitted with Cu-Ni tubes and special protection inside the end covers.

**Rubber type antivibration mounts** - Supplied separately, these are positioned under the base of the unit for “floor” installation.

**Sound proof cabinet** - Made of sheet metal and internally insulated, the cabinet is "integral kind" ( around the whole chiller, not only around the compressors ) to reach the best performance in noise reduction.

**Note:** to realize the baseframe consider that the dimensions of the sound proof cabinet are 300 mm longer, 300 mm wider and 200 mm higher than the standard unit.

**Witness tests** - The units are normally tested at the test bench prior to the shipment. On request, a second test can be carried out, at customer’s presence, in accordance with the procedures indicated on the test form. (Not available for units with Glycol mixtures).

**Soft start** – Electronic starting device to reduce inrush current. An overload protection is included (no need of compressors thermal relays).

## Installation notes

### Warning

Installation and maintenance are to be performed only by qualified personnel who are familiar with local codes and regulations, and who are experienced with this type of equipment. Must be avoided the unit installation in places that could be considered dangerous for all the maintenance operations.

### Handling

The chiller is mounted on heavy wooden skids to protect the unit from accidental damage and to permit easy handling and moving. It is recommended that all moving and handling be performed with the skids under the unit when possible and that the skids not be removed until the unit is in the final location.

If the unit must be hoisted, it is necessary to lift the unit by attaching cables or chains at the lifting holes in the evaporator tube sheets. Spreader bars must be used to protect the control cabinet and the other areas of the chiller.

### Location

A levelled and sufficiently strong floor is required. If necessary, additional structural members should be provided to transfer the weight of the unit to the nearest beams.

Rubber-in-shear isolators can be furnished and field placed under each corner of the package. A rubber anti-skid pad should be used under isolators if hold-down bolts are not used. Vibration isolator in all water piping connected to the chiller are recommended to avoid straining the piping and transmitting vibration and noise.

**Table 1 – Operating limits**

WHS 095.1÷539.4		HFC 134a
Max evaporator leaving water temperature	°C	15
Min evaporator leaving water temperature (without glycol)	°C	4
Min evaporator leaving water temperature (with glycol)	°C	-8
Min evaporator water $\Delta T$	°C	4
Max evaporator water $\Delta T$	°C	10
Min $\Delta T$ between leaving water evaporator and leav. water condenser	°C	16
Max $\Delta T$ between leaving water evaporator and leav. water condenser	°C	48
Min condenser entering water temperature	°C	15
Max condenser leaving water temperature	°C	55
Min condenser water $\Delta T$ (1 pass, 2 passes - $\Delta T$ 4÷8 °C)	°C	4
Max condenser water $\Delta T$ (1 pass, 2 passes - $\Delta T$ 4÷8 °C)	°C	8
Min condenser water $\Delta T$ (2 passes - $\Delta T$ 8÷15 °C)	°C	8
Max condenser water $\Delta T$ (2 passes - $\Delta T$ 8÷15 °C)	°C	15

**Table 2 – Evaporator fouling factors**

Fouling factors m <sup>2</sup> °C / kW	Cooling capacity correction factor	Power input correction factor	COP correction factor
0,0176	1,000	1,000	1,000
0,0440	0,978	0,986	0,992
0,0880	0,957	0,974	0,983
0,1320	0,938	0,962	0,975

**Table 3 – Condenser fouling factors**

Fouling factors m <sup>2</sup> °C / kW	Cooling capacity correction factor	Power input correction factor	COP correction factor
0,0440	1,000	1,000	1,000
0,0880	0,990	1,018	0,973
0,1320	0,981	1,036	0,945

**Table 4 – Ethylene glycol and low ambient temperature correction factors**

Air ambient temperature °C	-3	-8	-15	-23	-35
% of ethylene glycol by weight	10	20	30	40	50
Cooling capacity correction factor	0,991	0,982	0,972	0,961	0,946
Power input correction factor	0,996	0,992	0,986	0,976	0,966
Flow rate correction factor	1,013	1,040	1,074	1,121	1,178
Water pressure drops correction factor	1,070	1,129	1,181	1,263	1,308

**Table 5 – Low temperature operation performance factors**

Ethylene glycol/water leaving temperature °C	2	0	-2	-4	-6	-8
Min. % of ethylene glycol	10	20	20	30	30	30
Cooling capacity correction factor	0,842	0,785	0,725	0,670	0,613	0,562
Power input compressors correction factor	0,95	0,94	0,92	0,89	0,87	0,84

## Nomenclature

**WHS 226 . 2 ST 134**

**WHS** Water cooled  
Screw chiller

**095÷539** Unit size

**1**  
**2** N° of compressors  
**3**  
**4**

**ST** Standard version  
**ME** Condenserless version  
**LR** Version with liquid receiver

**134** Refrigerant HFC 134a



## Physical data WHS HFC 134a

“WHS” Unit size		095.1	114.1	132.1	146.1	191.2	210.2	226.2
Cooling capacity (1)	kW	334	399	462	510	666	735	792
Power input (1)	kW	81	90	103	110	160	171	180
McQuay Stargate™ Screw compressor	No.	1	1	1	1	2	2	2
Refrigerant circuits	No.	1	1	1	1	2	2	2
Refrigerant charge HFC 134a	kg	75	85	100	125	150	160	170
Oil charge	l	14	14	14	14	28	28	28
Min % of capacity reduction	%	25	25	25	25	12,5	12,5	12,5

### Evaporator

Evaporators / water volume	No./l	1/140	1/135	1/128	1/152	1/210	1/350	1/350
Max operating pressure	bar	10,5	10,5	10,5	10,5	10,5	10,5	10,5

### Condenser

Condensers / water volume	No./l	1/30	1/35	1/34	1/36	2/60	2/63	2/70
Max operating pressure	bar	16	16	16	16	16	16	16

### Weight and dimensions (cond. 1 pass, 2 passes $\Delta T$ 8±15 °C)

Standard unit shipping weight	kg	1830	1855	1886	1965	3395	3495	3515
Standard unit operating weight	kg	2000	2030	2050	2160	3640	3910	3940
Unit length	mm	3310	3310	3310	3310	4300	4300	4300
Unit width	mm	900	900	900	900	1290	1290	1290
Unit height	mm	1970	1970	1970	1970	2070	2070	2070

### Weight and dimensions (cond. 2 passes $\Delta T$ 4±8 °C, cond. 1 pass+total heat recovery)

Standard unit shipping weight	kg	2000	2045	2090	2185	3735	3850	3890
Standard unit operating weight	kg	2200	2240	2300	2430	4070	4330	4380
Unit length	mm	3310	3310	3310	3310	4300	4300	4300
Unit width	mm	900	900	900	900	1290	1290	1290
Unit height	mm	1970	1970	1970	1970	2070	2070	2070

“WHS” Unit size		248.2	266.2	306.3	325.3	343.3	361.3
Cooling capacity (1)	kW	871	934	1074	1139	1205	1268
Power input (1)	kW	195	207	251	262	273	285
McQuay Stargate™ Screw compressor	No.	2	2	3	3	3	3
Refrigerant circuits	No.	2	2	3	3	3	3
Refrigerant charge HFC 134a	kg	185	200	235	245	255	270
Oil charge	l	28	28	42	42	42	42
Min % of capacity reduction	%	12,5	12,5	8,3	8,3	8,3	8,3

### Evaporator

Evaporators / water volume	No./l	1/350	1/350	1/350	1/350	1/415	1/415
Max operating pressure	bar	16	16	16	16	16	16

### Condenser

Condensers / water volume	No./l	2/75	2/80	3/95	3/100	3/105	3/110
Max operating pressure	bar	10,5	10,5	10,5	10,5	10,5	10,5

### Weight and dimensions (cond. 1 pass, 2 passes $\Delta T$ 8±15 °C)

Standard unit shipping weight	kg	3560	3590	4960	4980	5110	5135
Standard unit operating weight	kg	3990	4020	5410	5430	5630	5660
Unit length	mm	4300	4300	3770	3770	3770	3770
Unit width	mm	1290	1290	2160	2160	2160	2160
Unit height	mm	2070	2070	2320	2320	2320	2320

### Weight and dimensions (cond. 2 passes $\Delta T$ 4±8 °C, cond. 1 pass+total heat recovery)

Standard unit shipping weight	kg	3945	3980	5490	5525	5670	5705
Standard unit operating weight	kg	4440	4490	6030	6080	6300	6340
Unit length	mm	4300	4300	3770	3770	3770	3770
Unit width	mm	1290	1290	2160	2160	2160	2160
Unit height	mm	2070	2070	2320	2320	2320	2320

Note: (1) Nominal cooling capacity and power input are based on: 12/7 °C entering/leaving evaporator water temperature; 30/35 °C entering/leaving condenser water temperature.

## Physical data WHS HFC 134a

"WHS" Unit size		<b>379.3</b>	<b>397.3</b>	<b>434.4</b>	<b>464.4</b>	<b>502.4</b>	<b>539.4</b>
Cooling capacity (1)	kW	1331	1394	1525	1629	1761	1893
Power input (1)	kW	298	309	344	366	391	416
McQuay Stargate™ Screw compressor	No.	3	3	4	4	4	4
Refrigerant circuits	No.	3	3	4	4	4	4
Refrigerant charge HFC 134a	kg	285	300	325	340	370	400
Oil charge	l	42	42	56	56	56	56
Min % of capacity reduction	%	8,3	8,3	6,25	6,25	6,25	6,25

### Evaporator

Evaporators / water volume	No./l	1/415	1/415	1/400	1/400	1/400	1/400
Max operating pressure	bar	16	16	16	16	16	16

### Condenser

Condensers / water volume	No./l	3/115	3/120	4/135	4/140	4/150	4/160
Max operating pressure	bar	10,5	10,5	10,5	10,5	10,5	10,5

### Weight and dimensions (cond. 1 pass, 2 passes ΔT 8÷15 °C)

Standard unit shipping weight	kg	5175	5205	6790	6830	6890	6940
Standard unit operating weight	kg	5710	5740	7580	7630	7690	7730
Unit length	mm	3770	3770	5151	5151	5151	5151
Unit width	mm	2160	2160	2240	2240	2240	2240
Unit height	mm	2320	2320	2320	2320	2320	2320

### Weight and dimensions (cond. 2 passes ΔT 4÷8 °C, cond. 1 pass+total heat recovery)

Standard unit shipping weight	kg	5750	5790	7595	7665	7750	7825
Standard unit operating weight	kg	6400	6450	8510	8600	8700	8780
Unit length	mm	3770	3770	5151	5151	5151	5151
Unit width	mm	2160	2160	2240	2240	2240	2240
Unit height	mm	2320	2320	2320	2320	2320	2320

Note: (1) Nominal cooling capacity and power input are based on: 12/7 °C entering/leaving evaporator water temperature; 30/35 °C entering/leaving condenser water temperature.

## Electrical data WHS HFC 134a

WHS unit size		<b>095.1</b>	<b>114.1</b>	<b>132.1</b>	<b>146.1</b>	<b>191.2</b>	<b>210.2</b>	<b>226.2</b>
Standard voltage (1)		400 V - 3f - 50 Hz						
Nominal unit current (2)	A	154	168	185	187	308	323	336
Max unit current (3)	A	193	217	255	257	386	412	436
Max unit inrush current (4)	A	631	631	631	631	785	786	799
Max unit current for wires sizing (5)	A	223	271	271	310	446	494	542

WHS unit size		<b>248.2</b>	<b>266.2</b>	<b>306.3</b>	<b>325.3</b>	<b>343.3</b>	<b>361.3</b>
Standard voltage (1)		400 V - 3f - 50 Hz					
Nominal unit current (2)	A	354	370	478	491	504	528
Max unit current (3)	A	472	510	605	628	651	690
Max unit inrush current (4)	A	799	816	941	954	967	973
Max unit current for wires sizing (5)	A	581	620	717	765	813	852

WHS unit size		<b>379.3</b>	<b>397.3</b>	<b>434.4</b>	<b>464.4</b>	<b>502.4</b>	<b>539.4</b>
Standard voltage (1)		400 V - 3f - 50 Hz					
Nominal unit current (2)	A	543	561	648	676	706	736
Max unit current (3)	A	729	768	824	872	944	1016
Max unit inrush current (4)	A	988	1005	1110	1138	1153	1183
Max unit current for wires sizing (5)	A	891	930	988	1084	1162	1240

Note: (1) Allowed voltage tolerance ± 10%. Voltage unbalance between phases must be within ± 3%.  
 (2) Absorbed current referred to nominal condition: 12/7 °C entering/leaving evaporator water temperature; 30/35 °C entering/leaving condenser water temperature.  
 (3) Absorbed current referred to the following conditions: 14/9 °C entering/leaving evaporator water temperature; 50/55°C entering/leaving condenser water temperature.  
 (4) Absorbed current of compressor n°1+(n°2)+(n°3) at nominal conditions+inrush current of last compressor (n°4).  
 (5) Compressor FLA (Full Load Ampere).

## Sound pressure level WHS

WHS Unit size	Sound pressure level at 1 m from the in free field ( rif. 2 x 10 <sup>-5</sup> )								
	63 Hz	125 Hz	250 Hz	500 Hz	1000 Hz	2000 Hz	4000 Hz	8000 Hz	dBA
095.1	53,6	56,2	71,1	74,5	69,7	65,6	63,9	59,5	75,2
114.1	54,6	57,2	72,1	75,5	70,7	66,6	64,9	60,5	76,2
132.1	56,6	59,2	74,1	77,5	72,7	68,6	66,9	62,5	78,2
146.1	56,6	59,2	74,1	77,5	72,7	68,6	66,9	62,5	78,2
191.2	56,2	58,8	73,7	77,1	72,3	68,2	66,5	62,1	77,8
210.2	56,6	59,2	74,1	77,5	72,7	68,6	66,9	62,5	78,2
226.2	57,1	59,7	74,6	78,0	73,2	69,1	67,4	63,0	78,7
248.2	58,2	60,8	75,7	79,1	74,3	70,2	68,5	64,1	79,8
266.2	59,1	61,7	76,6	80,0	75,2	71,1	69,4	65,0	80,7
306.3	57,5	60,1	75,0	78,4	73,6	69,5	67,8	63,4	79,2
325.3	57,8	60,4	75,3	78,7	73,9	69,8	68,1	63,7	79,5
343.3	58,2	60,8	75,7	79,1	74,3	70,2	68,5	64,1	79,8
361.3	58,9	61,5	76,4	79,8	75,0	70,9	69,2	64,8	80,6
379.3	59,6	62,2	77,1	80,5	75,7	71,6	69,9	65,5	81,2
397.3	60,2	62,8	77,7	81,1	76,3	72,2	70,5	66,1	81,8
434.4	58,6	61,2	76,1	79,5	74,7	70,6	68,9	64,5	80,3
464.4	59,1	61,7	76,6	80,0	75,2	71,1	69,4	65,0	80,8
502.4	60,2	62,8	77,7	81,1	76,3	72,2	70,5	66,1	81,9
539.4	61,1	63,7	78,6	82,0	77,2	73,1	71,4	67,0	82,8

## Sound pressure level WHS with sound proof cabinet

WHS Unit size	Sound pressure level at 1 m from the in free field ( rif. 2 x 10 <sup>-5</sup> )								
	63 Hz	125 Hz	250 Hz	500 Hz	1000 Hz	2000 Hz	4000 Hz	8000 Hz	dBA
095.1	41,6	44,2	59,1	62,5	57,7	53,6	51,9	47,5	63,2
114.1	42,6	45,2	60,1	63,5	58,7	54,6	52,9	48,5	64,2
132.1	44,6	47,2	62,1	65,5	60,7	56,6	54,9	50,5	66,2
146.1	44,6	47,2	62,1	65,5	60,7	56,6	54,9	50,5	66,2
191.2	44,2	46,8	61,7	65,1	60,3	56,2	54,5	50,1	65,8
210.2	44,6	47,2	62,1	65,5	60,7	56,6	54,9	50,5	66,2
226.2	45,1	47,7	62,6	66,0	61,2	57,1	55,4	51,0	66,7
248.2	46,2	48,8	63,7	67,1	62,3	58,2	56,5	52,1	67,8
266.2	47,1	49,7	64,6	68,0	63,2	59,1	57,4	53,0	68,7
306.3	45,5	48,1	63,0	66,4	61,6	57,5	55,8	51,4	67,2
325.3	45,8	48,4	63,3	66,7	61,9	57,8	56,1	51,7	67,5
343.3	46,2	48,8	63,7	67,1	62,3	58,2	56,5	52,1	67,8
361.3	46,9	49,5	64,4	67,8	63,0	58,9	57,2	52,8	68,6
379.3	47,6	50,2	65,1	68,5	63,7	59,6	57,9	53,5	69,2
397.3	48,2	50,8	65,7	69,1	64,3	60,2	58,5	54,1	69,8
434.4	46,6	49,2	64,1	67,5	62,7	58,6	56,9	52,5	68,3
464.4	47,1	49,7	64,6	68,0	63,2	59,1	57,4	53,0	68,8
502.4	48,2	50,8	65,7	69,1	64,3	60,2	58,5	54,1	69,9
539.4	49,1	51,7	66,6	70,0	65,2	61,1	59,4	55,0	70,8

Note: Average sound pressure level rated in accordance to ISO 3744, free field semispheric conditions.

## Sound pressure level correction factor for different distances

WHS Unit size	Distance (m)					
	1	5	10	15	20	25
095.1	0	8,7	13,7	16,9	19,2	21,1
114.1	0	8,7	13,7	16,9	19,2	21,1
132.1	0	8,7	13,7	16,9	19,2	21,1
146.1	0	8,7	13,7	16,9	19,2	21,1
191.2	0	8,4	13,4	16,5	18,8	20,6
210.2	0	8,3	13,3	16,4	18,7	20,5
226.2	0	8,3	13,3	16,4	18,7	20,5
248.2	0	8,3	13,3	16,4	18,7	20,5
266.2	0	8,3	13,3	16,4	18,7	20,5
306.3	0	7,9	12,7	15,8	18,0	19,8
325.3	0	7,9	12,7	15,8	18,0	19,8
343.3	0	7,9	12,7	15,8	18,0	19,8
361.3	0	7,9	12,7	15,8	18,0	19,8
379.3	0	7,9	12,7	15,8	18,0	19,8
397.3	0	7,9	12,7	15,8	18,0	19,8
434.4	0	7,8	12,5	15,6	17,9	19,7
464.4	0	7,8	12,5	15,6	17,9	19,7
502.4	0	7,8	12,5	15,6	17,9	19,7
539.4	0	7,8	12,5	15,6	17,9	19,7

# Standard ratings WHS 095.1 ÷ 226.2

WHS unit size	Evaporator leaving water temp. (°C)	ENTERING CONDENSER WATER TEMPERATURE °C															
		15		20		25		30		35		40		45		50	
		Cool. cap. (kW)	Power input (kW)	Cool. cap. (kW)	Power input (kW)	Cool. cap. (kW)	Power input (kW)	Cool. cap. (kW)	Power input (kW)	Cool. cap. (kW)	Power input (kW)	Cool. cap. (kW)	Power input (kW)	Cool. cap. (kW)	Power input (kW)	Cool. cap. (kW)	Power input (kW)
WHS 095.1	4	341	59	329	65	317	71	304	76	291	82	277	88	264	95	249	104
	5	351	60	339	66	327	72	314	78	300	83	287	90	273	97	258	105
	6	363	61	350	67	337	73	324	79	310	85	296	91	282	98	267	106
	7	373	60	360	67	347	74	334	80	320	86	306	92	291	99	276	107
	8	384	61	371	68	358	75	344	81	330	87	315	94	300	100	285	108
	9	396	62	382	69	368	76	354	82	340	89	325	95	310	102	294	110
WHS 114.1	4	407	66	393	73	379	80	364	86	348	94	333	101	315	110	299	120
	5	422	67	406	74	390	81	375	88	359	95	343	103	327	112	309	121
	6	433	68	418	75	403	82	387	89	371	96	354	104	337	113	319	122
	7	447	69	431	76	415	83	399	90	382	98	366	106	348	113	330	123
	8	459	70	443	77	427	84	411	92	394	99	377	107	359	115	341	125
	9	472	69	456	77	440	85	423	93	407	101	389	109	371	116	352	126
WHS 132.1	4	472	72	456	81	440	90	422	100	404	109	385	119	367	132	346	146
	5	489	73	471	82	453	91	436	101	417	111	399	120	379	133	358	146
	6	503	73	485	83	467	93	449	102	431	112	411	122	391	134	371	147
	7	519	74	500	84	481	94	462	103	444	113	424	123	404	135	383	148
	8	533	73	514	84	495	95	477	105	457	114	438	124	416	136	396	149
	9	546	74	528	85	510	96	491	106	472	115	451	126	430	138	408	150
WHS 146.1	4	522	75	503	86	484	97	464	106	444	116	423	127	401	139	380	154
	5	538	76	519	87	500	98	479	108	459	118	438	129	415	140	393	155
	6	554	75	535	87	516	99	495	109	474	120	453	130	430	142	407	156
	7	572	76	552	88	532	100	510	110	489	121	468	132	444	144	421	157
	8	590	75	569	88	548	101	528	111	505	122	483	133	459	145	435	158
	9	607	76	586	89	565	102	544	112	521	124	498	134	474	147	449	160
WHS 191.2	4	682	118	657	130	632	142	607	153	581	164	554	177	527	191	499	208
	5	704	120	678	132	652	144	626	155	600	167	573	179	545	193	516	210
	6	723	120	698	133	673	146	647	158	619	170	591	181	563	196	534	211
	7	747	123	720	135	693	147	666	160	639	172	611	184	581	198	551	213
	8	769	122	742	136	715	150	687	163	659	175	630	187	600	201	570	216
	9	790	124	763	138	736	152	709	165	680	178	650	190	619	204	588	219
WHS 210.2	4	753	127	725	139	697	151	670	163	641	177	612	190	581	206	550	224
	5	776	127	748	140	720	153	691	166	662	178	631	193	600	209	569	226
	6	797	129	770	142	743	155	713	169	683	181	652	195	621	210	588	228
	7	823	131	794	144	765	157	735	171	705	184	674	198	641	213	608	231
	8	848	130	818	145	788	160	758	174	727	187	695	201	662	216	627	233
	9	872	130	842	146	812	162	781	176	749	190	717	204	683	219	648	236
WHS 226.2	4	810	133	781	146	752	159	722	173	692	187	660	202	627	219	593	241
	5	832	132	804	147	776	162	746	176	714	189	682	205	648	222	614	243
	6	859	134	829	149	799	164	768	178	736	192	703	208	670	224	634	244
	7	884	134	854	150	824	166	792	180	759	195	726	210	691	227	656	246
	8	911	136	880	152	849	168	816	183	783	198	749	213	714	230	677	249
	9	937	136	905	153	873	170	840	185	806	201	771	216	736	233	699	251

**Note:** (1) Nominal cooling capacity and power input are based on  $\Delta T=5^{\circ}\text{C}$  entering/leaving condenser water temperature; evaporator fouling factor= $0,0176\text{ m}^2\text{ }^{\circ}\text{C}/\text{kW}$ ; condenser fouling factor= $0,0440\text{ m}^2\text{ }^{\circ}\text{C}/\text{kW}$ .

# Standard ratings WHS 248.2 ÷ 361.3

WHS unit size	Evaporator leaving water temp. (°C)	ENTERING CONDENSER WATER TEMPERATURE °C															
		15		20		25		30		35		40		45		50	
		Cool. cap. (kW)	Power input (kW)	Cool. cap. (kW)	Power input (kW)	Cool. cap. (kW)	Power input (kW)	Cool. cap. (kW)	Power input (kW)	Cool. cap. (kW)	Power input (kW)	Cool. cap. (kW)	Power input (kW)	Cool. cap. (kW)	Power input (kW)	Cool. cap. (kW)	Power input (kW)
WHS 248.2	4	891	138	859	155	827	172	794	187	760	204	725	221	688	243	651	266
	5	919	140	886	157	853	174	819	189	785	206	749	224	712	244	674	268
	6	946	142	913	159	880	176	845	192	810	209	773	227	735	247	696	270
	7	974	142	940	160	906	178	871	195	835	211	798	230	759	249	720	273
	8	1002	145	968	162	934	179	898	197	861	214	823	233	784	252	744	275
	9	1032	145	997	163	962	181	925	200	888	217	849	236	809	255	767	277
WHS 266.2	4	955	147	921	164	887	181	851	200	815	218	777	240	739	263	698	291
	5	985	148	950	166	915	184	879	202	842	221	802	242	763	266	722	293
	6	1016	148	979	167	942	186	905	205	868	224	829	244	788	268	747	295
	7	1045	150	1008	169	971	188	934	207	895	226	855	247	814	271	771	297
	8	1075	150	1038	170	1001	190	962	210	923	229	882	250	840	273	796	299
	9	1106	150	1068	171	1030	192	991	211	951	232	909	253	866	275	822	302
WHS 306.3	4	1098	186	1059	204	1020	222	979	241	936	259	893	278	849	302	802	328
	5	1132	186	1092	206	1052	226	1009	244	967	263	923	282	878	306	830	331
	6	1167	189	1126	209	1085	229	1041	248	998	267	953	287	906	309	858	335
	7	1202	188	1160	210	1118	232	1074	251	1030	271	984	291	936	313	887	339
	8	1238	191	1195	213	1152	235	1107	255	1062	275	1016	295	967	317	917	342
	9	1275	192	1231	215	1187	238	1141	259	1095	279	1046	300	998	321	947	346
WHS 325.3	4	1166	190	1124	211	1082	232	1038	250	994	271	948	292	900	316	852	344
	5	1203	193	1159	214	1115	235	1071	254	1026	275	979	296	931	320	881	348
	6	1237	194	1194	216	1151	238	1105	258	1059	278	1010	300	962	324	911	351
	7	1274	196	1230	219	1186	242	1139	262	1092	282	1043	304	993	328	941	355
	8	1312	198	1267	221	1222	244	1174	266	1127	287	1076	308	1026	332	972	359
	9	1352	199	1305	223	1258	247	1210	270	1161	291	1110	312	1058	337	1004	363
WHS 343.3	4	1233	197	1188	219	1143	241	1098	261	1051	281	1002	305	952	331	900	361
	5	1271	201	1225	222	1179	243	1133	265	1085	286	1035	308	984	335	931	365
	6	1309	203	1262	225	1215	247	1168	269	1120	290	1069	313	1017	339	963	368
	7	1346	204	1300	227	1254	250	1205	273	1155	294	1103	317	1051	342	995	372
	8	1387	205	1339	229	1291	253	1241	276	1191	299	1138	321	1084	346	1028	375
	9	1426	207	1378	232	1330	257	1279	280	1227	303	1173	326	1119	351	1062	379
WHS 361.3	4	1295	205	1249	228	1203	251	1156	274	1106	297	1055	323	1002	352	948	386
	5	1337	208	1289	231	1241	254	1192	277	1141	301	1090	327	1036	356	981	389
	6	1377	208	1328	233	1279	258	1230	281	1178	305	1125	331	1070	359	1014	392
	7	1418	211	1368	236	1318	261	1268	285	1215	309	1161	335	1105	363	1048	396
	8	1457	212	1408	238	1359	264	1306	289	1252	313	1198	340	1140	368	1082	400
	9	1501	213	1450	240	1399	267	1345	292	1291	317	1235	343	1177	372	1117	404

**Note:** (1) Nominal cooling capacity and power input are based on  $\Delta T=5^{\circ}\text{C}$  entering/leaving condenser water temperature; evaporator fouling factor= $0,0176\text{ m}^2\text{ }^{\circ}\text{C}/\text{kW}$ ; condenser fouling factor= $0,0440\text{ m}^2\text{ }^{\circ}\text{C}/\text{kW}$ .

# Standard ratings WHS 379.3 ÷ 539.4

WHS unit size	Evaporator leaving water temp. (°C)	ENTERING CONDENSER WATER TEMPERATURE °C															
		15		20		25		30		35		40		45		50	
		Cool. cap. (kW)	Power input (kW)	Cool. cap. (kW)	Power input (kW)	Cool. cap. (kW)	Power input (kW)	Cool. cap. (kW)	Power input (kW)	Cool. cap. (kW)	Power input (kW)	Cool. cap. (kW)	Power input (kW)	Cool. cap. (kW)	Power input (kW)	Cool. cap. (kW)	Power input (kW)
WHS 379.3	4	1361	212	1312	237	1263	262	1212	286	1161	312	1107	340	1053	373	995	411
	5	1401	215	1352	240	1303	265	1251	290	1198	316	1144	344	1088	376	1029	414
	6	1445	216	1394	242	1343	268	1291	294	1237	320	1181	348	1124	380	1064	417
	7	1489	214	1436	243	1383	272	1331	298	1275	324	1218	352	1160	384	1100	420
	8	1530	217	1478	246	1426	275	1371	301	1315	328	1257	357	1197	388	1136	424
	9	1574	219	1521	248	1468	277	1412	305	1355	332	1296	361	1235	392	1172	428
WHS 397.3	4	1425	217	1374	245	1323	273	1270	299	1216	327	1160	359	1102	395	1042	437
	5	1467	221	1416	248	1365	275	1310	303	1256	331	1198	362	1139	398	1078	439
	6	1514	222	1460	250	1406	278	1351	307	1295	335	1237	366	1177	402	1114	441
	7	1557	223	1503	252	1449	281	1394	309	1336	339	1276	370	1215	404	1152	444
	8	1604	224	1548	254	1492	284	1436	313	1377	342	1316	374	1254	408	1190	448
	9	1649	225	1593	256	1537	287	1479	317	1419	347	1358	378	1294	412	1228	451
WHS 434.4	4	1560	251	1503	278	1446	305	1387	329	1327	355	1265	382	1201	413	1136	450
	5	1608	254	1550	281	1492	308	1432	335	1370	360	1307	387	1242	418	1175	454
	6	1658	257	1598	285	1538	313	1477	340	1415	366	1350	393	1284	424	1216	459
	7	1705	259	1646	288	1587	317	1525	344	1461	372	1394	399	1326	429	1257	464
	8	1759	261	1697	291	1635	321	1572	349	1507	376	1440	404	1370	435	1299	469
	9	1810	262	1747	294	1684	326	1620	355	1553	382	1485	410	1414	440	1342	474
WHS 464.4	4	1668	267	1607	295	1546	323	1483	350	1419	378	1353	408	1285	442	1214	483
	5	1719	269	1657	298	1595	327	1532	355	1466	383	1399	414	1329	448	1257	487
	6	1771	272	1708	302	1645	332	1580	361	1513	389	1444	419	1373	453	1300	492
	7	1824	274	1760	305	1696	336	1629	366	1561	395	1491	426	1418	459	1344	497
	8	1880	274	1814	307	1748	340	1680	371	1611	401	1539	432	1465	465	1388	502
	9	1934	276	1867	310	1800	344	1731	376	1660	406	1587	437	1512	470	1435	507
WHS 502.4	4	1802	280	1737	312	1672	344	1604	375	1535	408	1463	444	1389	485	1313	534
	5	1858	282	1791	315	1724	348	1655	381	1585	414	1512	450	1437	490	1359	537
	6	1915	283	1847	318	1779	353	1708	386	1636	419	1561	455	1484	496	1405	541
	7	1971	285	1902	321	1833	357	1761	391	1688	425	1612	461	1534	501	1452	546
	8	2031	287	1960	324	1889	361	1816	396	1741	431	1663	467	1583	506	1501	551
	9	2090	288	2018	327	1946	366	1872	401	1794	437	1716	472	1634	512	1550	556
WHS 539.4	4	1937	294	1867	330	1797	366	1724	402	1650	439	1573	481	1494	529	1412	584
	5	1996	296	1925	333	1854	370	1780	406	1704	444	1625	486	1544	533	1461	587
	6	2058	299	1985	336	1912	373	1836	411	1758	450	1679	491	1595	537	1510	591
	7	2122	300	2046	339	1970	378	1893	416	1814	455	1732	497	1648	542	1561	596
	8	2182	300	2106	341	2030	382	1952	421	1872	461	1788	502	1702	548	1613	599
	9	2247	300	2169	343	2091	386	2012	426	1929	467	1844	508	1756	554	1666	604

**Note:** (1) Nominal cooling capacity and power input are based on  $\Delta T=5^{\circ}\text{C}$  entering/leaving condenser water temperature; evaporator fouling factor= $0,0176\text{ m}^2\text{ }^{\circ}\text{C}/\text{kW}$ ; condenser fouling factor= $0,0440\text{ m}^2\text{ }^{\circ}\text{C}/\text{kW}$ .

# Evaporator pressure drop (WHS 095.1 – 539.4)

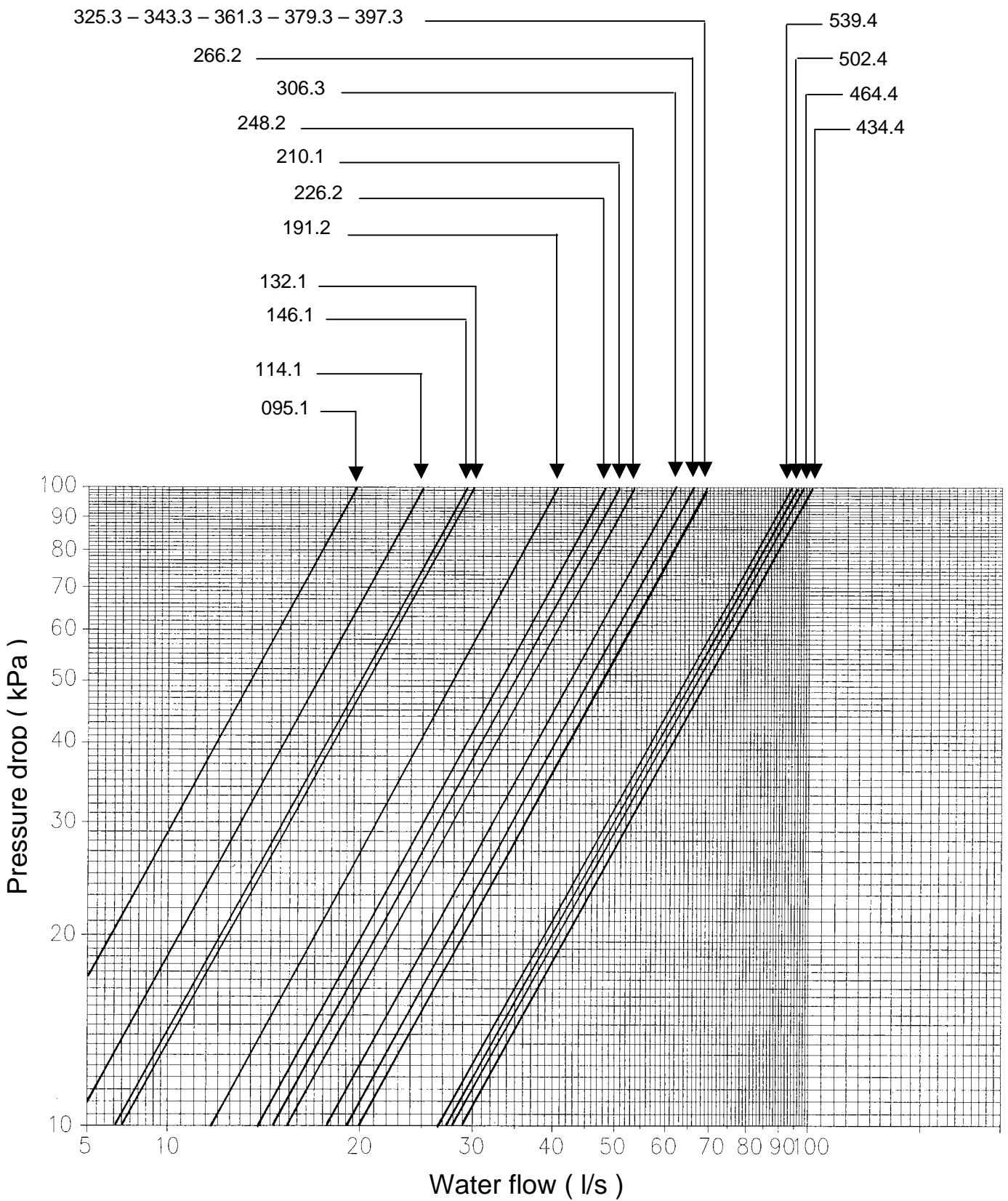

# Condenser (1 pass) – heat recov. cond. (1 pass) pressure drop

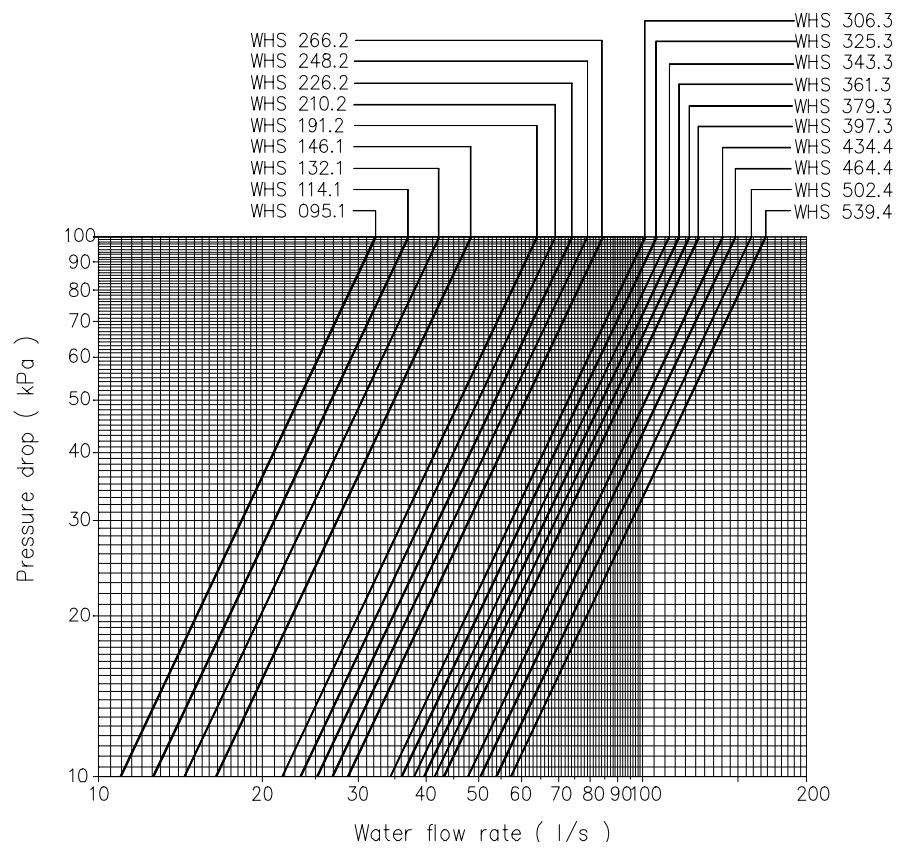



## Condenser (2 passes – $\Delta T 4\div 8\text{ }^{\circ}\text{C}$ ) pressure drop

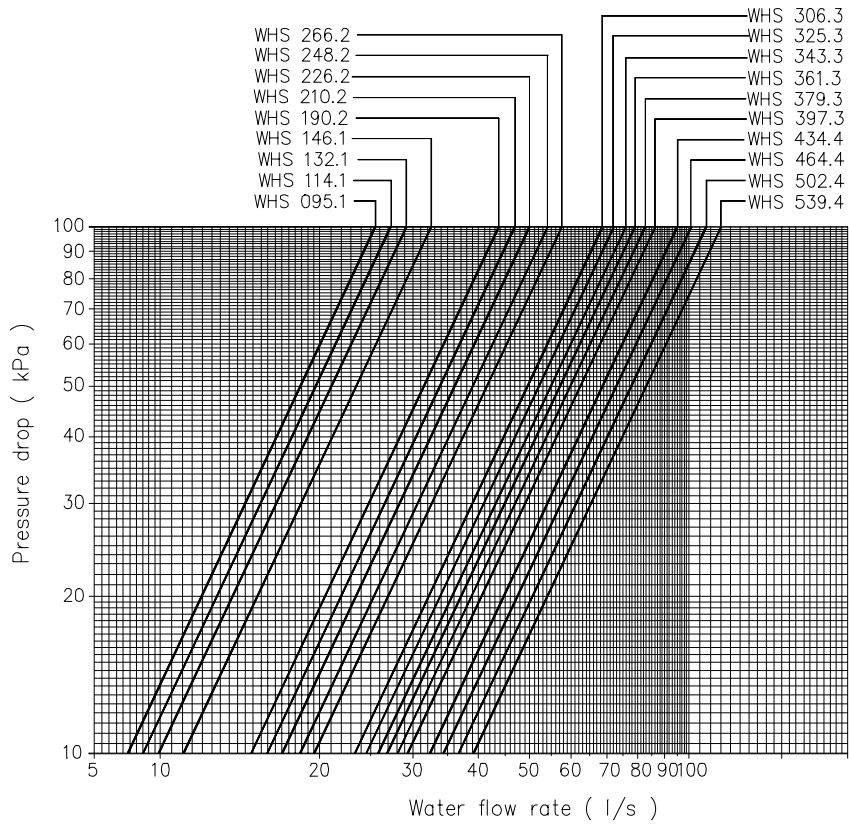

## Condenser (2 passes – $\Delta T 8\div 15\text{ }^{\circ}\text{C}$ ) pressure drop

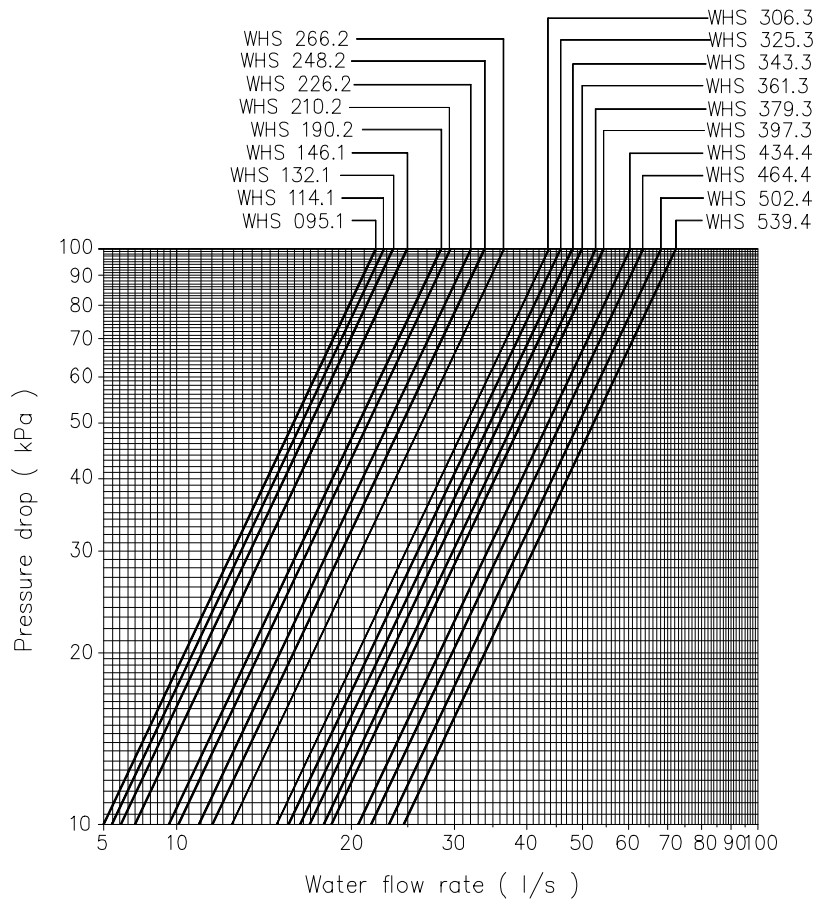

## Partial heat recovery ratings WHS 095.1 ÷ 539.4

WHS Unit	Leaving desuperheaters water temperature °C	Entering condenser water temperature °C				
		30	35	40	45	50
		Heating capacity (kW)	Heating capacity (kW)	Heating capacity (kW)	Heating capacity (kW)	Heating capacity (kW)
WHS 095.1	40	43,7	69,4	92,8	114,7	135,2
	45	39,3	62,5	83,6	103,4	121,8
	50	35,8	56,9	76,1	94,0	110,8
WHS 114.1	40	51,6	82,1	110,0	135,6	159,9
	45	46,5	73,9	99,1	122,2	144,1
	50	42,3	67,3	90,2	111,2	131,1
WHS 132.1	40	59,6	95,2	127,5	158,5	187,4
	45	53,7	85,8	114,9	142,8	168,9
	50	48,8	78,1	104,5	130,0	153,7
WHS 146.1	40	65,4	104,3	139,9	173,0	204,0
	45	58,9	93,9	126,0	155,8	183,8
	50	53,6	85,5	114,7	141,8	167,3
WHS 191.2	40	87,1	138,6	185,3	229,1	269,7
	45	78,5	124,9	167,0	206,4	243,0
	50	71,4	113,7	151,9	187,9	221,1
WHS 210.2	40	95,5	152,0	203,3	251,2	296,2
	45	86,1	136,9	183,1	226,3	266,8
	50	78,3	124,6	166,6	205,9	242,8
WHS 226.2	40	102,5	163,1	218,2	270,0	318,4
	45	92,3	146,9	196,6	243,3	286,8
	50	84,0	133,7	178,9	221,4	261,0
WHS 248.2	40	112,4	178,8	239,6	296,5	350,5
	45	101,3	161,1	215,9	267,1	315,8
	50	92,2	146,6	196,5	243,1	287,4
WHS 266.2	40	120,3	191,6	256,9	319,2	377,0
	45	108,4	172,6	231,4	287,5	339,6
	50	98,6	157,1	210,6	261,6	309,1
WHS 306.3	40	139,7	222,4	297,2	367,4	432,8
	45	125,9	200,4	267,8	331,0	389,9
	50	114,5	182,3	243,7	301,2	354,8
WHS 325.3	40	147,7	234,9	314,0	388,6	457,5
	45	133,1	211,6	282,9	350,1	412,1
	50	121,1	192,6	257,4	318,6	375,0
WHS 343.3	40	155,9	247,7	331,0	409,8	482,5
	45	140,4	223,1	298,2	369,1	434,7
	50	127,8	203,1	271,4	335,9	395,6
WHS 361.3	40	163,8	260,5	348,7	431,8	509,7
	45	147,5	234,7	314,2	389,0	459,2
	50	134,3	213,6	285,9	354,0	417,9
WHS 379.3	40	171,8	273,3	366,0	454,2	536,5
	45	154,8	246,2	329,7	409,2	483,4
	50	140,8	224,1	300,0	372,3	439,9
WHS 397.3	40	179,6	286,3	383,7	476,2	563,4
	45	161,8	258,0	345,7	429,0	507,5
	50	147,2	234,7	314,6	390,4	461,9
WHS 434.4	40	197,1	313,3	417,9	516,2	607,5
	45	177,6	282,3	376,5	465,1	547,3
	50	161,6	256,9	342,6	423,2	498,0
WHS 464.4	40	210,4	334,4	446,9	552,1	649,8
	45	189,5	301,2	402,6	497,4	585,4
	50	172,5	274,1	366,3	452,6	532,7
WHS 502.4	40	226,9	361,2	483,2	598,6	705,3
	45	204,4	325,4	435,3	539,3	635,4
	50	186,0	296,1	396,2	490,7	578,2
WHS 539.4	40	243,5	387,9	519,6	644,2	761,4
	45	219,4	349,4	468,1	580,4	685,9
	50	199,6	318,0	426,0	528,1	624,2

Note: (1) Leaving evaporator water temperature 7°C -  $\Delta T$  5°C;  $\Delta T$  condenser water temperature 5°C.

### Heating capacity correction factors for different evaporator leaving water temp.

Evaporator leaving water temp.	9	8	7	6	5	4
Heating capacity correction factor	1,062	1,029	1,000	0,973	0,941	0,914

# Total heat recovery ratings WHS 095.1 ÷ 306.3

WHS Unit size	Leaving chilled water temp. °C	LEAVING HEAT RECOVERY CONDENSER WATER TEMPERATURE - °C											
		40			45			50			55		
		Cool. cap. (kW)	Pow. input (kW)	Heat. cap. (kW)	Cool. cap. (kW)	Pow. input (kW)	Heat. cap. (kW)	Cool. cap. (kW)	Pow. input (kW)	Heat. cap. (kW)	Cool. cap. (kW)	Pow. input (kW)	Heat. cap. (kW)
WHS 095.1	4	291	82	362	277	88	355	264	95	348	249	104	343
	5	300	83	372	287	90	365	273	97	358	258	105	352
	6	310	85	383	296	91	375	282	98	368	267	106	361
	7	320	86	394	306	92	386	291	99	378	276	107	371
	8	330	87	405	315	94	397	300	100	389	285	108	381
	9	340	89	416	325	95	408	310	102	400	294	110	392
WHS 114.1	4	348	94	429	333	101	421	315	110	412	299	120	406
	5	359	95	441	343	103	432	327	112	425	309	121	417
	6	371	96	453	354	104	444	337	113	436	319	122	428
	7	382	98	466	366	106	457	348	113	448	330	123	439
	8	394	99	479	377	107	469	359	115	461	341	125	452
	9	407	101	492	389	109	483	371	116	473	352	126	464
WHS 132.1	4	404	109	497	385	119	489	367	132	484	346	146	477
	5	417	111	512	399	120	503	379	133	497	358	146	490
	6	431	112	526	411	122	517	391	134	510	371	147	503
	7	444	113	540	424	123	531	404	135	522	383	148	516
	8	457	114	555	438	124	545	416	136	535	396	149	529
	9	472	115	570	451	126	560	430	138	550	408	150	541
WHS 146.1	4	444	116	544	423	127	533	401	139	524	380	154	518
	5	459	118	559	438	129	550	415	140	539	393	155	531
	6	474	120	576	453	130	565	430	142	555	407	156	546
	7	489	121	591	468	132	582	444	144	570	421	157	560
	8	505	122	608	483	133	597	459	145	585	435	158	576
	9	521	124	626	498	134	613	474	147	602	449	160	591
WHS 191.2	4	581	164	723	554	177	709	527	191	697	499	208	685
	5	600	167	744	573	179	730	545	193	716	516	210	704
	6	619	170	765	591	181	749	563	196	737	534	211	723
	7	639	172	786	611	184	771	581	198	755	551	213	742
	8	659	175	809	630	187	793	600	201	777	570	216	762
	9	680	178	832	650	190	815	619	204	798	588	219	783
WHS 210.2	4	641	177	793	612	190	778	581	206	763	550	224	751
	5	662	178	816	631	193	800	600	209	785	569	226	771
	6	683	181	838	652	195	822	621	210	807	588	228	792
	7	705	184	862	674	198	845	641	213	828	608	231	813
	8	727	187	887	695	201	869	662	216	852	627	233	834
	9	749	190	911	717	204	893	683	219	875	648	236	857
WHS 226.2	4	692	187	853	660	202	836	627	219	821	593	241	809
	5	714	189	876	682	205	860	648	222	844	614	243	831
	6	736	192	901	703	208	884	670	224	867	634	244	853
	7	759	195	925	726	210	909	691	227	891	656	246	875
	8	783	198	951	749	213	933	714	230	915	677	249	898
	9	806	201	977	771	216	958	736	233	940	699	251	922
WHS 248.2	4	760	204	935	725	221	918	688	243	903	651	266	889
	5	785	206	961	749	224	944	712	244	927	674	268	913
	6	810	209	988	773	227	969	735	247	953	696	270	937
	7	835	211	1015	798	230	997	759	249	978	720	273	963
	8	861	214	1043	823	233	1024	784	252	1005	744	275	988
	9	888	217	1072	849	236	1052	809	255	1032	767	277	1013
WHS 266.2	4	815	218	1002	777	240	986	739	263	971	698	291	960
	5	842	221	1031	802	242	1013	763	266	998	722	293	985
	6	868	224	1060	829	244	1041	788	268	1024	747	295	1010
	7	895	226	1087	855	247	1069	814	271	1052	771	297	1036
	8	923	229	1117	882	250	1098	840	273	1080	796	299	1062
	9	951	232	1147	909	253	1128	866	275	1107	822	302	1090
WHS 306.3	4	936	259	1159	893	278	1136	849	302	1116	802	328	1096
	5	967	263	1193	923	282	1169	878	306	1148	830	331	1126
	6	998	267	1227	953	287	1203	906	309	1179	858	335	1157
	7	1030	271	1262	984	291	1236	936	313	1212	887	339	1189
	8	1062	275	1296	1016	295	1271	967	317	1246	917	342	1221
	9	1095	279	1333	1046	300	1306	998	321	1280	947	346	1254

## Total heat recovery ratings WHS 325.3 ÷ 539.4

WHS Unit size	Leaving chilled water temp. °C	LEAVING HEAT RECOVERY CONDENSER WATER TEMPERATURE - °C											
		40			45			50			55		
		Cool. cap. (kW)	Pow. input (kW)	Heat. cap. (kW)	Cool. cap. (kW)	Pow. input (kW)	Heat. cap. (kW)	Cool. cap. (kW)	Pow. input (kW)	Heat. cap. (kW)	Cool. cap. (kW)	Pow. input (kW)	Heat. cap. (kW)
WHS 325.3	4	994	271	1227	948	292	1202	900	316	1180	852	344	1160
	5	1026	275	1261	979	296	1236	931	320	1214	881	348	1192
	6	1059	278	1297	1010	300	1271	962	324	1247	911	351	1224
	7	1092	282	1333	1043	304	1307	993	328	1281	941	355	1258
	8	1127	287	1372	1076	308	1343	1026	332	1317	972	359	1291
	9	1161	291	1408	1110	312	1380	1058	337	1353	1004	363	1326
WHS 343.3	4	1051	281	1292	1002	305	1268	952	331	1244	900	361	1223
	5	1085	286	1330	1035	308	1303	984	335	1279	931	365	1257
	6	1120	290	1367	1069	313	1341	1017	339	1314	963	368	1291
	7	1155	294	1405	1103	317	1378	1051	342	1351	995	372	1325
	8	1191	299	1445	1138	321	1415	1084	346	1387	1028	375	1361
	9	1227	303	1483	1173	326	1454	1119	351	1426	1062	379	1398
WHS 361.3	4	1106	297	1361	1055	323	1336	1002	352	1314	948	386	1294
	5	1141	301	1399	1090	327	1374	1036	356	1350	981	389	1328
	6	1178	305	1438	1125	331	1412	1070	359	1386	1014	392	1363
	7	1215	309	1479	1161	335	1451	1105	363	1424	1048	396	1400
	8	1252	313	1519	1198	340	1491	1140	368	1463	1082	400	1437
	9	1291	317	1560	1235	343	1531	1177	372	1502	1117	404	1474
WHS 379.3	4	1161	312	1429	1107	340	1404	1053	373	1383	995	411	1364
	5	1198	316	1469	1144	344	1444	1088	376	1420	1029	414	1400
	6	1237	320	1510	1181	348	1484	1124	380	1459	1064	417	1437
	7	1275	324	1551	1218	352	1523	1160	384	1498	1100	420	1474
	8	1315	328	1594	1257	357	1565	1197	388	1537	1136	424	1513
	9	1355	332	1637	1296	361	1607	1235	392	1578	1172	428	1552
WHS 397.3	4	1216	327	1497	1160	359	1473	1102	395	1452	1042	437	1434
	5	1256	331	1539	1198	362	1513	1139	398	1491	1078	439	1472
	6	1295	335	1580	1237	366	1555	1177	402	1532	1114	441	1509
	7	1336	339	1624	1276	370	1596	1215	404	1571	1152	444	1548
	8	1377	342	1668	1316	374	1640	1254	408	1612	1190	448	1589
	9	1419	347	1714	1358	378	1684	1294	412	1655	1228	451	1628
WHS 434.4	4	1327	355	1632	1265	382	1598	1201	413	1566	1136	450	1539
	5	1370	360	1678	1307	387	1643	1242	418	1610	1175	454	1580
	6	1415	366	1728	1350	393	1691	1284	424	1657	1216	459	1624
	7	1461	372	1777	1394	399	1739	1326	429	1702	1257	464	1669
	8	1507	376	1827	1440	404	1789	1370	435	1751	1299	469	1714
	9	1553	382	1877	1485	410	1838	1414	440	1799	1342	474	1762
WHS 464.4	4	1419	378	1744	1353	408	1709	1285	442	1676	1214	483	1647
	5	1466	383	1793	1399	414	1759	1329	448	1724	1257	487	1691
	6	1513	389	1845	1444	419	1807	1373	453	1771	1300	492	1738
	7	1561	395	1898	1491	426	1860	1418	459	1821	1344	497	1786
	8	1611	401	1951	1539	432	1911	1465	465	1871	1388	502	1834
	9	1660	406	2005	1587	437	1964	1512	470	1923	1435	507	1884
WHS 502.4	4	1535	408	1885	1463	444	1850	1389	485	1818	1313	534	1791
	5	1585	414	1939	1512	450	1903	1437	490	1869	1359	537	1839
	6	1636	419	1993	1561	455	1956	1484	496	1921	1405	541	1888
	7	1688	425	2050	1612	461	2011	1534	501	1973	1452	546	1938
	8	1741	431	2106	1663	467	2066	1583	506	2027	1501	551	1990
	9	1794	437	2164	1716	472	2123	1634	512	2081	1550	556	2043
WHS 539.4	4	1650	439	2027	1573	481	1992	1494	529	1961	1412	584	1936
	5	1704	444	2083	1625	486	2048	1544	533	2014	1461	587	1986
	6	1758	450	2142	1679	491	2105	1595	537	2069	1510	591	2038
	7	1814	455	2201	1732	497	2162	1648	542	2125	1561	596	2092
	8	1872	461	2262	1788	502	2222	1702	548	2182	1613	599	2146
	9	1929	467	2324	1844	508	2281	1756	554	2241	1666	604	2202

# Dimensions WHS 095.1 ÷ 146.1

## LEGENDA/LEGEND

- 1- PANNELLO ELETTRICO  
ELECTRICAL PANEL
- 2- ASOLA INGRESSO ALIMENTAZIONE 150x200  
POWER CONNECTIONS SLOT 150x200
- 3- N.4 FORI Ø28 PER FISSAGGIO ANTIVIBRANTI  
4 HOLES Ø28 FOR ISOLATOR MOUNTING
- 4- INGRESSO ACQUA EVAPOR. (CONNESSIONE VICTAULIC)  
EVAPORATOR WATER INLET (Victaulic connection)
- 5- USCITA ACQUA EVAPOR. (CONNESSIONE VICTAULIC)  
EVAPORATOR WATER OUTLET (Victaulic connection)
- 6- CONNESSIONE INGRESSO ACQUA CONDENSATORE 5" GAS  
CONDENSER WATER INLET CONNECTION 5" GAS
- 7- CONNESSIONE USCITA ACQUA CONDENSATORE 5" GAS  
CONDENSER WATER OUTLET CONNECTION 5" GAS
- 8- CONNESSIONE ACQUA CONDENSATORE  
CONDENSER WATER CONNECTION
- 9- CABINA INSONORIZZANTE COMPRESSORI (OPTIONAL)  
COMPRESSORS ENCLOSURE (OPTIONAL)

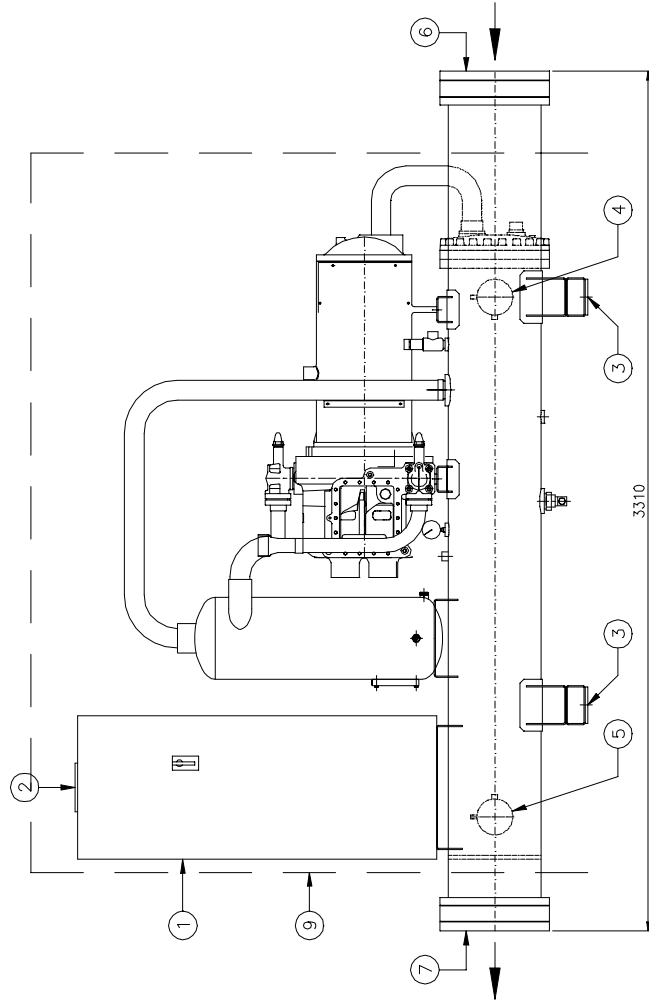
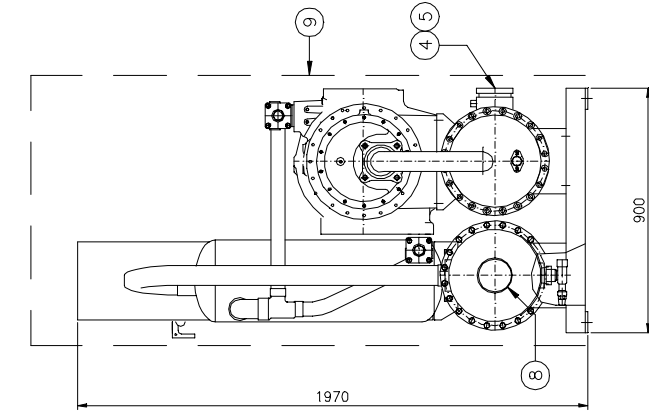

# Dimensions WHS 191.2 ÷ 266.2

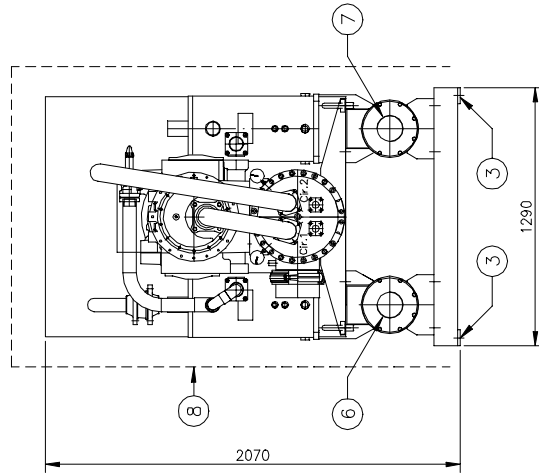
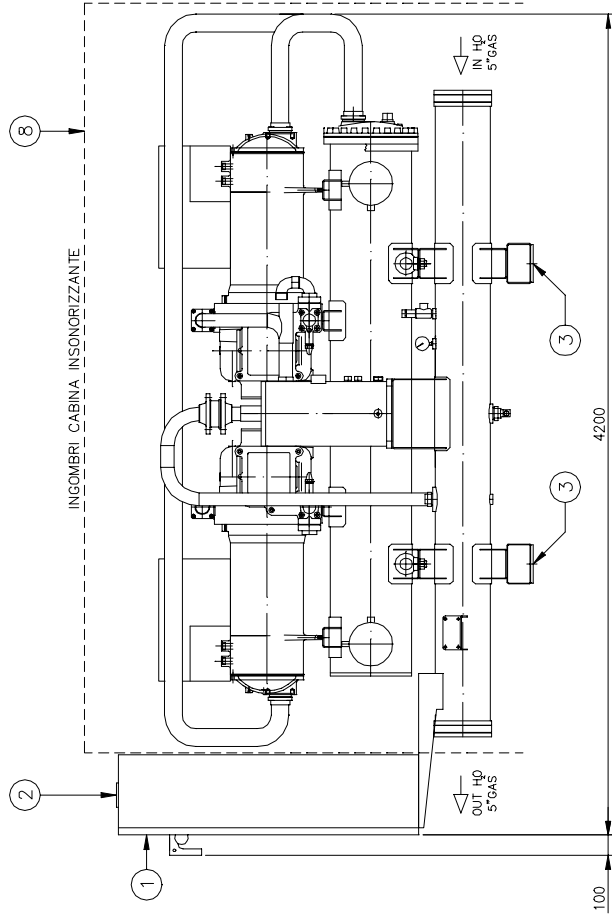

## LEGENDA/LEGEND

- 1- PANNELLO ELETTRICO  
ELECTRICAL PANEL
- 2- ASOLA INGRESSO ALIMENTAZIONE 150x260  
POWER CONNECTIONS SLOT 150x260
- 3- N.4 FORI Ø28 PER FISSAGGIO ANTIVIBRANTI  
4 HOLES Ø28 FOR ISOLATOR MOUNTING
- 4- INGRESSO ACQUA EVAPOR. (CONNESSIONE VITTAUCC. Ø 219,1)  
EVAPORATOR WATER INLET (Ø 219,1 Victaulic connection)
- 5- USCITA ACQUA EVAPOR. (CONNESSIONE VITTAUCC. Ø 219,1)  
EVAPORATOR WATER OUTLET (Ø 219,1 Victaulic connection)
- 6- CONNESSIONE INGRESSO ACQUA CONDENSATORE CIRC.1 - 5" GAS  
CIRC. 1 CONDENSER WATER INLET CONNECTION 5" GAS
- 7- CONNESSIONE INGRESSO ACQUA CONDENSATORE CIRC.2 - 5" GAS  
CIRC. 2 CONDENSER WATER INLET CONNECTION 5" GAS
- 8- CABINA INSONORIZZANTE COMPRESSORI (OPTIONAL)  
COMPRESSORS ENCLOSURE (OPTIONAL)

# Dimensions WHS 306.3 ÷ 397.3

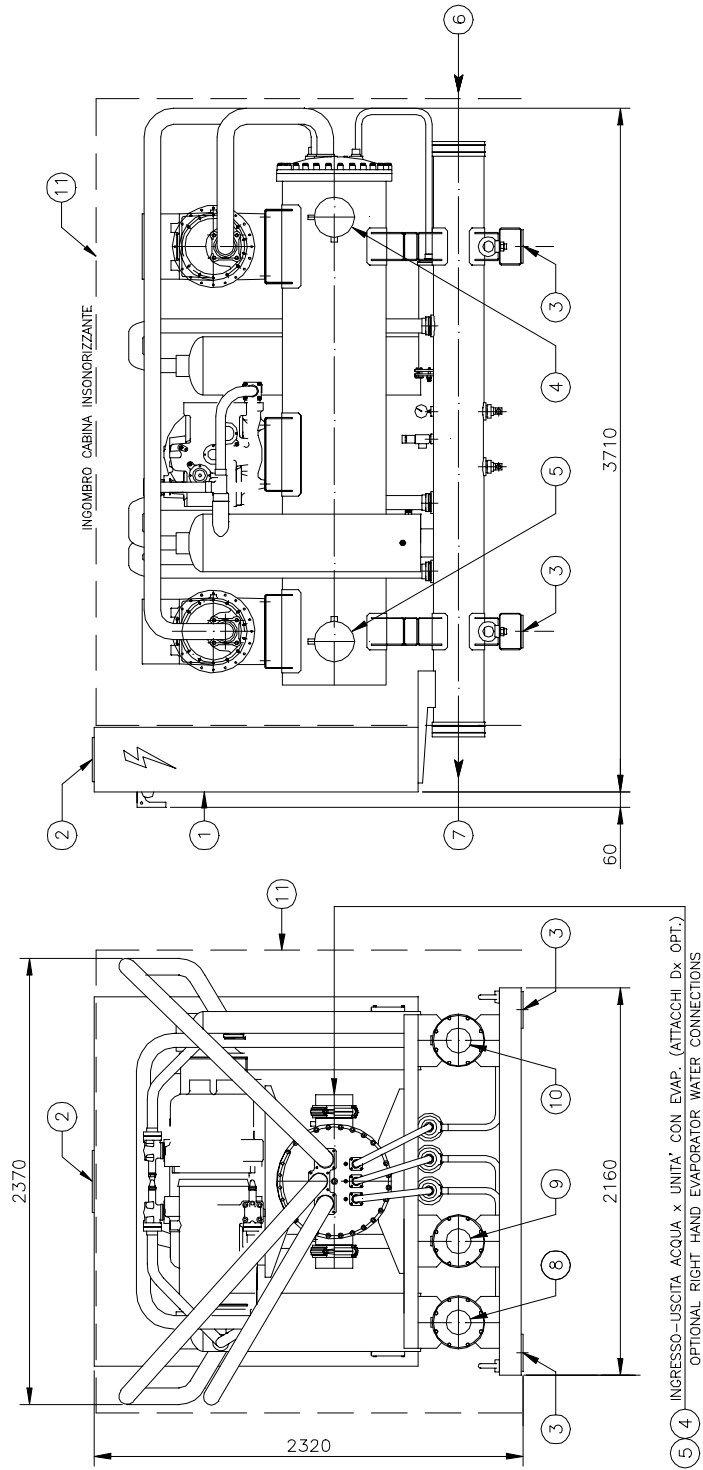

## LEGENDA / LEGEND

- 1- PANNELLO ELETTRICO  
ELECTRICAL PANEL
- 2- ASOLA INGRESSO ALIMENTAZIONE 150x260  
POWER CONNECTIONS SLOT 150x260
- 3- N.4. FORI #28 PER FISSAGGIO ANTIVIBRANTI  
4 HOLES #28 FOR ISOLATOR MOUNTING
- 4- INGRESSO ACQUA EVAPOR. (CONNESSIONE VICTAULIC #e 219,1)  
EVAPORATOR WATER INLET (P# 219,1 Victaulic connection)
- 5- USCITA ACQUA EVAPOR. (CONNESSIONE VICTAULIC #e 219,1)  
EVAPORATOR WATER OUTLET (P# 219,1 Victaulic connection)
- 6- CONNESSIONE INGRESSO ACQUA CONDENSATORE 5" GAS  
CONDENSER WATER INLET CONNECTION 5" GAS
- 7- CONNESSIONE USCITA ACQUA CONDENSATORE 5" GAS  
CONDENSER WATER OUTLET CONNECTION 5" GAS
- 8- CONNESSIONI ACQUA CONDENSATORI CIRC. 1  
CIRC. 1 CONDENSER WATER CONNECTION
- 9- CONNESSIONI ACQUA CONDENSATORI CIRC. 3  
CIRC. 2 CONDENSER WATER CONNECTION
- 10- CONNESSIONI ACQUA CONDENSATORI CIRC. 2  
CIRC. 3 CONDENSER WATER CONNECTION
- 11- CABINA INSONORIZZANTE COMPRESSORI (OPZIONALE)  
COMPRESSORS ENCLOSURE (OPTIONAL)

- 3 4 INGRESSO- USCITA ACQUA x UNITA' CON EVAP. (ATTACCHI D.x. OPT.)  
OPTIONAL RIGHT HAND EVAPORATOR WATER CONNECTIONS

# Dimensions WHS 434.4 ÷ 539.4

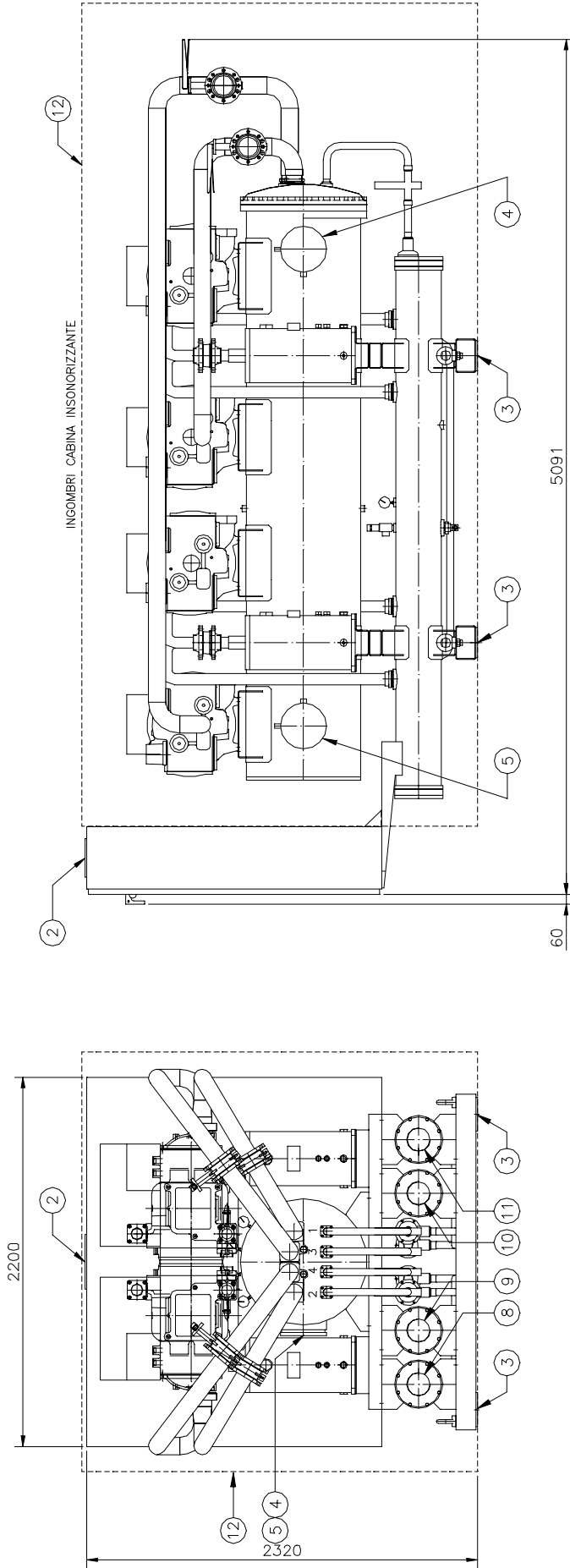

## LEGENDA / LEGEND

- |  |  |   |
|--|--|---|
| 1- PANNELLO ELETTRICO<br>ELECTRICAL PANEL  | 5- USCITA ACQUA EVAPOR. (CONNESSIONE VITAUILLIC #273)<br>EVAPORATOR WATER OUTLET (#273 Vitaulic connection)    | 9- CONNESSIONI ACQUA CONDENSATORI CIRC. 2 - 5" GAS FEMM.<br>CIRC. 2 CONDENSER WATER CONNECTION - 5" GAS FEMALE  |
| 2- ASOLA INGRESSO ALIMENTAZIONE 150x260<br>POWER CONNECTIONS SLOT 150x260                                    | 6- CONNESSIONE INGRESSO ACQUA CONDENSATORE 5" GAS<br>CONDENSER WATER INLET CONNECTION 5" GAS                   | 10- CONNESSIONI ACQUA CONDENSATORI CIRC. 3 - 5" GAS FEMM.<br>CIRC. 3 CONDENSER WATER CONNECTION - 5" GAS FEMALE |
| 3- N.4 FORI Ø28 PER ESSACCO ANTIURTO<br>4 HOLES Ø28 FOR ISOLATOR MOUNTING                                    | 7- CONNESSIONE USCITA ACQUA CONDENSATORE 5" GAS<br>CONDENSER WATER OUTLET CONNECTION 5" GAS                    | 11- CONNESSIONI ACQUA CONDENSATORI CIRC. 4 - 5" GAS FEMM.<br>CIRC. 4 CONDENSER WATER CONNECTION - 5" GAS FEMALE |
| 4- INGRESSO ACQUA EVAPOR. (CONNESSIONE VITAUILLIC #273)<br>EVAPORATOR WATER INLET (#273 Vitaulic connection) | 8- CONNESSIONI ACQUA CONDENSATORI CIRC. 1 - 5" GAS FEMM.<br>CIRC. 1 CONDENSER WATER CONNECTION - 5" GAS FEMALE | 12- CABINA INSONORIZZANTE COMPRESSORI (OPZIONALE)<br>COMPRESSORS ENCLOSURE (OPTIONAL)                           |



## WHS Frame 4 - Technical specifications

To supply and install, where specified in the project n ..... unit(s) water cooled chiller with cooling capacity of ..... kW, to cool ..... l/sec. of water from ..... °C to ....., condenser entering water temperature ....°C, condenser leaving water temperature ....°C. The unit should work with electricity at ..... V, 3ph, 50Hz. The electrical power absorbed should not exceed ..... kW. The units COP will be at least ..... at the working conditions of the project. Part load COP will be at least ..... at the working conditions of the project. For the units with 1, 2, 3 or 4 compressors the chillers will have (1), (2), (3) or (4) independent refrigerant circuits, and the respective electronic microprocessor will allow the starting of the compressors. Each chiller will be factory assembled on a robust baseframe. The unit will be tested at full load in the factory at the nominal working conditions and water temperatures. Before shipment a full test will be held to avoid any losses, and the units will be filled with oil and refrigerant.

**Refrigerant** - only HFC 134a will be accepted.

**Noise level and vibrations** – Sound pressure level at 1 meter distance in free field shall not exceed .....dBA  
Vibration level should not exceed 2 mm/s.

Units will have the following components:

**Compressors** - The compressor should be single screw type with one main screw rotor that meshes with two diametrically opposed gaterotors. The two exactly opposed gaterotors create two exactly opposed compression cycles which results in balanced forces acting on the compressor. The gaterotors should be constructed of a carbon impregnated engineered composite material. The gaterotor supports will be constructed of cast iron. The semi-hermetic compressor should be gas-cooled.

Oil injection shall be used for this compressor in order to get high COP at high condensing pressure. The unit should be provided with an oil separator and it will be the high efficiency, augmented gas impingement type to maximise oil extraction.

**Evaporator** - The units will be supplied with one direct expansion evaporator (2 evaporators for units with 4 compressors) with refrigerant inside the tubes and water outside (shell side) with carbon steel tube sheets, with straight copper tubes that are spirally wound internally for higher efficiencies, expanded on the tube plates. The external shell, will be linked with an electrical heater to prevent freezing to -28 C ambient temperature, commanded by a thermostat and will be covered with a closed cell insulation material. Each evaporator will have 1, 2, 3, o 4 refrigerant circuits one for each compressor. Each evaporator is manufactured in accordance to ISPEL approval.

**Condensers** - Condensers will be shell and cleanable, through-tube type. The unit will have one condensers per circuit. Each condenser shall have a carbon steel and seamless, integrally finned high efficiency copper tubes, roll expanded into heavy carbon steel tube sheets. Water heads shall be removable and include vent and drain plugs. Condensers will come complete with liquid shut-off valve, spring loaded relief valve.

**Electronic expansion valve** - Each refrigerant circuit will be equipped with all the necessary components in order to ensure the workings and service (dehydration filter, liquid sight glass, shut-off valve, load connection, pressure switch etc.) and an electronic expansion valve that allows a simple control system that quickly interacts at load variations. This valve combines two functions: liquid solenoid and electronic expansion valve. It is managed directly by a microprocessor.

**Control panel** - Field power connection, control interlock terminals, and unit control system should be centrally located in an electric panel (IP 54). Power and starting controls should be separate from safety and operating controls in different compartments of the same panel. Starting will be star/delta type. Power and starting controls should include fuses and contactors for each compressor winding. Operating and safety controls should include energy saving control; emergency stop switch; overload protection for compressor motor; high and low pressure cut-out switch (for each refrigerant circuit); anti-freeze thermostat; compressor lead-lag switch (on 2 compressor units only); cut-out switch for each compressor; operating hour meter (for each compressor).

All of the information regarding the unit will be reported on a display and with the internal built-in calender and clock that will switch the unit ON/OFF during day time all year long.

**Regulation of cooling capacity** - Each unit will have a microprocessor for the control and operation of the unit that should have a infinitely variable capacity control down to 6,25% (four compressors), 8,3% (three compressors), to 12,5% (two compressors), to 25% (one compressor) of the cooling capacity.

**Refrigerant piping** - Refrigerant circuit should include a factory insulated suction line, manual liquid line shut-off valve with charging connection, refrigerant filter drier with replaceable core, sensor indicator, electronic expansion valve and relief valve.





We reserve the right to make changes in design and construction at any time without notice, thus the cover picture is not binding.



**McQuay Italia S.P.A.**  
S.S. Nettunense, km 12+300 – 00040 Cecchina (Roma) Italia – Tel. (06) 937311 – Fax (06) 9374014 – E-mail: [mcquay@mcquayitalia.com](mailto:mcquay@mcquayitalia.com)