

Water cooled screw chillers

PROXIMUS “EVOLUTION”

SE (Standard Efficiency) 111.1÷596.2

Cooling capacity from 388 a 2093 kW

XE (High Efficiency) 111.1÷596.2

Cooling capacity from 431 to 2196 kW

50Hz – Refrigerant: R-410A



McQuay is participating in the Eurovent Certification Programme. Product are as listed in the Eurovent Directory of Certified Products and on the web site www.eurovent-certification.com



FEATURES AND ADVANTAGES

New water cooled screw chillers McQuay PROXIMUS “EVOLUTION”

McQuay International introduces its new water cooled screw chillers equipped with new compressors.

McQuay water cooled PROXIMUS “EVOLUTION” is a new range of chillers using the last generation of McQuay StarGate™ single screw compressors. They are manufactured by McQuay to satisfy the requirements of the consultants and the end users. McQuay PROXIMUS “EVOLUTION” units are designed to minimise energy costs while maximising the refrigeration capacities. Once again McQuay has developed a line of chillers unsurpassed in performance and quality that will meet the most stringent requirements of comfort cooling and process applications.

McQuay’s chiller design experience, combined with outstanding features, makes the PROXIMUS “EVOLUTION” chiller unmatched in the industry.

R-410A refrigerant – Ecological and efficient

McQuay has optimized Stargate™ compressors to operate with R-410A, ecological refrigerant with zero ODP (Ozone Depletion Potential) and very low GWP (Global Warming Potential), that means low value of the “direct effect” in the formula of TEWI (Total Equivalent Warming Impact).

This refrigerant is safe and chemically stable and is listed in ASHRAE Standard-34 (*Number Designation and Safety Classification For Refrigerants*) as “A-1” refrigerant: lowest toxicity, non-flammable.

An essential feature of this refrigerant is its very high cooling capacity: for example R-410A has nearly 50% higher cooling capacity in comparison to R22.

The research also indicates a favourable energy consumption when used with low condensing temperatures and this gives money saving and good premises for a very low value of the “indirect effect” in the TEWI formula.

An advantage is the high heat transfer coefficients (found also during the test) in the evaporator and condenser, therefore providing further potential for increased efficiencies. This refrigerant is a blend of two different types of refrigerant: 50% of R32 and 50% of R125.

Because of the negligible temperature glide (< 0,15 °C), the general usability can be seen similar to a pure refrigerant (as HFC134a) so this refrigerant doesn’t present any maintenance problem even if it’s a refrigerants blend .

Significant differences in the thermodynamic properties for this refrigerant (e.g. mass and volume flow, vapour density, pressure levels) have been evaluated and design changes to the single-screw compressor, piping and controls have been made to optimize the chiller’s performance and reliability.



Lower noise – higher flexibility

The compressor allows a constant gas flow. This compression process eliminates completely gas pulsations, that are one of the main reasons for quiet operation. The oil injection also results in a significant mechanical noise reduction, in a perfect moving parts cooling and clearances sealing to reach very high volumetric efficiency.

The gas compressor discharge chambers are designed to act as attenuators, based on the harmonic wave principle with destructive interference, thus always resulting almost equal to zero. The extremely low noise compressor performance allows the use of Proximus “Evolution” chiller for all applications.

Lower vibration levels – higher reliability

Since the moving components in the McQuay Single Screw Compressor are purely rotational and the loads are basically balanced, the dynamic forces and vibrations created by the system are very low. This reduced vibration results in less movement to refrigerant lines and other parts of the system.

The extremely low vibration levels, inherent with the single-screw design, will not pass through system piping and allow objectionable resonated sound to be carried into the building.

Infinitely variable capacity control – Higher control of the room ambient

Cooling capacity control is infinitely variable by means of a capacity slide controlled by microprocessor system. Each unit has infinitely variable capacity control from 100% down to 25% (one compressor unit), down to 12,5% (two compressors units). This modulation allows the compressor capacity to exactly match the building cooling load without any leaving evaporator water temperature fluctuation. This chilled water temperature fluctuation is avoided only with a stepless control, such as McQuay International has.

With a compressor load step control in fact, the compressor capacity, at partial loads, will be too high or too low compared to the building cooling load. The result is a decrease in chiller energy costs, particularly at the part-load conditions at which the chiller operates most of the time.

Additionally, in some case there should be the possibility to avoid inertial tank in the water circuit.

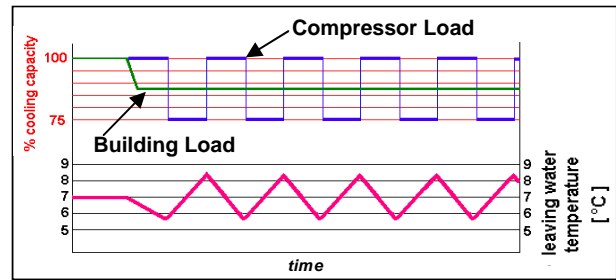

ELWT fluctuation with steps capacity control (4 steps)

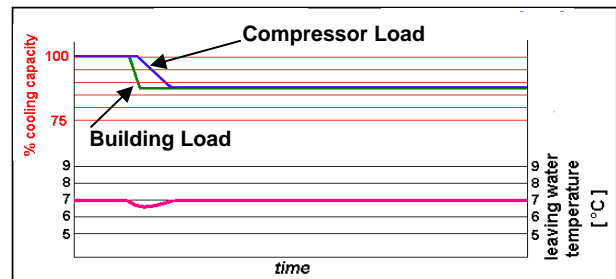

NO ELWT fluctuation with McQuay stepless capacity control (4 steps)

Unmatched serviceability

Field serviceability has not been sacrificed. Inspection covers allows visual inspection of the main screw and gaterotors.

Outstanding reliability features

Unsurpassed Efficiency

- Zero clearance fit between the gaterotor/s and main screw rotor virtually eliminates leakage between the high and low-pressure sides during compression. Special gaterotor material made from an advanced composite, temperature stable material makes a zero clearance design possible.
- The Proximus “Evolution” water-cooled chiller is equipped with the most advanced means of refrigerant flow control available. An electronic expansion valve coupled with the MicroTech II C Plus controller's control logic provides excellent operating efficiencies both at full and part load operation.
- Infinite unloading matches compressor capacity to load.
- Full factory testing of the unit with water hookups helps provides a trouble-free start-up. Extensive quality control checks during testing means that each equipment protection and operating control is properly adjusted and operates correctly before it leaves the factory. Factory-installed options minimize field expenses and startup labor.
- The rugged design of the single-screw compressor allows it to be tolerant of liquid slugging. Screw chiller will start and operate under conditions that would often destroy other compressors.
- Very low loading enhances the bearing and compressor reliability. Balanced forces result in the elimination of the high loads inherent in twin-screw compressors.
- Integral to the basic design of the single-screw compressor, the main screw rotor shaft and the gaterotor shaft/s cross at right angles in the compressor. The result is ample space to locate heavy duty bearings and increase compressor reliability since no limitations are placed on bearing design as found in twin-screw compressors.

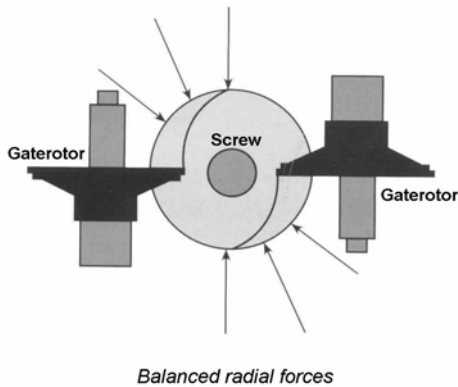

Single Screw Compressor

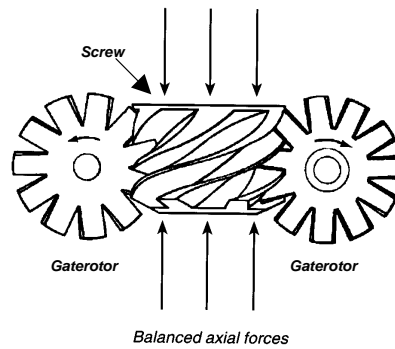

Single Screw Compressor

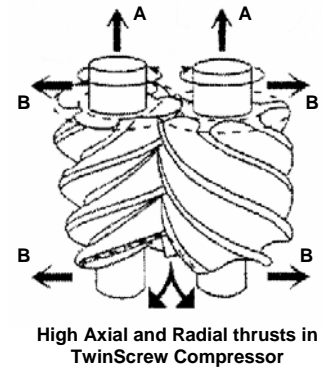

Twin Screw Compressor

Code requirements – Safety and observant of laws/directives

All water cooled units are designed and manufactured in accordance with applicable selections of the following which are equivalent to American Air-conditioning industry applicable codes:

Rating of chillers: EN 12055.

Construction of pressure vessel: Pressure Equipment 97/23/EC (PED).

Machinery Directive: 98/37/EC

Low Voltage: 2006/95/EC

Electromagnetic Compatibility: 2004/108/EC

Electrical & Safety codes: IEC 60204–1.

Manufacturing Quality Stds: ISO 9001:2000.

Certifications

All units manufactured by McQuay Italia S.p.A. are CE marked, complying with European directives in force, concerning manufacturing and safety. On request units can be produced complying with laws in force in non European countries (ASME, GOST, etc.), and with other applications, such as naval (RINA, etc.).

GENERAL CHARACTERISTICS

Structure

The chiller is equipped with brackets directly installed on heat exchangers. The evaporator and the suction piping are appropriately insulated to prevent condensation. Unit is provided with lifting holes.

Screw compressors

The Stargate™ single-screw compressor has a well balanced compression mechanism which gives main bearing design life of 3-4 times greater than twin-screws and eliminates expensive and complicated thrust balancing schemes.

Oil injection is used for these compressors in order to get high EER at high condensing pressure. The oil supplied to the compressor performs three basic functions: oil for capacity control actuation, oil for bearing lubrication, oil for sealing. The oil is injected via fixed ports in the casing around the rotor.

Compressors have an infinitely variable capacity control down to 25% of its total capacity. This control is made by means of capacity slides controlled by microprocessors.

The unit is furnished with an external (for Frame 4) or integrated (for Frame 3200) high efficiency oil separator to maximise oil extraction.

The compressor is provided with a liquid injection circuit to reach oil cooling.

Standard start is star-delta type.

Evaporator

The units are supplied with optimised shell and tubes evaporator pass that allows a perfect oil circulation and so a perfect oil return to the compressor. It is direct expansion with refrigerant inside the tubes and water outside (shell side) with carbon steel tube sheets, with straight copper tubes that are spirally wound internally for higher efficiencies, expanded on the tube plates. The external shell is covered with a closed cell insulation material.

Each evaporator has 1 or 2 circuits, one for each compressor and is manufactured in accordance to PED approval. The evaporator water outlet connections are provided with Victaulic Kit.

Condensers

Condensers are shell and tubes cleanable, through-tube type. The unit has independent condensers, one per circuit. Each condenser has a carbon steel and seamless, integrally finned high efficiency copper tubes, roll expanded into heavy carbon steel tube sheets. Water heads are removable and include vent and drain plugs. Condensers come complete with liquid shut-off valve, spring loaded relief valve.

Electronic expansion valve (EEXV)

Proximus "Evolution" water cooled chiller is equipped with the most advanced electronic expansion valve to achieve precise control of refrigerant mass flow. As today's system requires improved energy efficiency, tighter temperature control, wider range of operating conditions and incorporate features like remote monitoring and diagnostics, the application of electronic expansion valves becomes mandatory. Proximus "Evolution" electronic expansion valve proposes features that makes it unique: short opening and closing time, high resolution, positive shut-off function to eliminate use of additional solenoid valve, highly linear flow capacity, continuous modulation of mass flow without stress in the refrigerant circuit and corrosion resistance stainless steel body.

EEXV strength point is the capacity to work with lower ΔP between high and low pressure side, than a thermostatic expansion valve. The electronic expansion valve allows to system to work with low condenser pressure (winter time) without any refrigerant flow problems and with a perfect chilled water leaving temperature control. This feature becomes more important in Proximus "Evolution" that works with R-410A: the research indicates a favourable energy consumption when this refrigerant is used with low condensing temperatures.

Refrigerant Circuit

Each unit has 1 or 2 independent refrigerant circuits with one compressor per circuit, including:

- High and low pressure switches
- Moisture liquid indicator
- High efficiency oil separator
- Replaceable core filter-drier
- Electronic expansion valve

Electrical control panel

Power and control are located into two sections of the main panel that is manufactured to insure protection for all weather conditions.

The power panel is fitted with an interlocked door main isolator to prevent access while power supply is on. Electrical panel is IP54.

Power section includes

The power section includes contactors, all compressors fuses and control circuit transformer. Additional space is provided for an easy installation of the various optional accessories provided to enhance the Proximus "Evolution" units capabilities.

MicroTech II C Plus controller

MicroTech II C Plus controller is installed as standard on all the units; it can be used to modify unit set points and check control parameters. A display illustrates the machine's operating status, programmable values and setpoints e.g. temperatures, and pressures of fluids (water, refrigerant). Device controls maximise the McQuay chillers energy efficiency and reliability characteristics. It uses sophisticated software with predictive logic to select the most energy efficient combination of compressor, expansion device and condenser fan to keep stable operating conditions and maximise energy efficiency. The compressors are automatically rotated to ensure equal operating hours. MicroTech II C Plus protects critical components in response to external signals from its system sensors measuring: motor temperatures, refrigerant gas and oil pressures, correct phases sequence and phase loss.

Control section - main features:

- Chillers enabled to work in partial failure condition thanks to the distributed multiprocessor logic system
- Management of the compressor capacity slide and the EEXV valve according to the distributed multiprocessor logic system
- Full routine operation at condition of:
 - High pressure value
 - High thermal load
 - High evaporator entering water temperature (start-up)
- Display of evaporator entering/leaving water temperature
- Display of condensing-evaporating temperature and pressure, suction and discharge superheating temperature for each circuit
- Leaving water cooled temperature regulation. Temperature tolerance $\pm 0,1^{\circ}\text{C}$
- Compressors and evaporator/condenser pumps hours counter
- Display of Status Safety Devices
- Start up numbers and compressors working hours equalization
- Excellent management of compressors load
- Cooling tower's fans management according to condensing pressure
- Automatic re-start in case of power supply interruption (adjustable)
- Soft Load
- Return Reset
- AOT Reset (optional)
- Setpoint Reset (optional)
- Demand limit or Current limit (optional)

Safety for each refrigerant circuit

- High pressure (pressure switch)
- Compressor overload (optional)
- High Discharge Temperature on the compressor
- Phase Monitor
- Star / Delta Transition Failed
- Low Delta Pressure between Suction and Discharge
- Low pressure ratio
- High oil pressure drop
- Low oil pressure

System security

- Phase monitor
- Freeze protection
- An evaporator's flow controller input (stops the unit)
- Remote on/off input.
- Emergency stop (shuts down all compressors)

Regulation type

Proportional + integral + derivative regulation on the input probe of the evaporator water leaving temperature.

MicroTech II C Plus terminal

The MicroTech II C Plus terminal has following features:

- 4-lines by 20-character liquid crystal display back lighted
- Key-pad consisting of 15 keys " clear language display "

- Memory to protect the data
- General faults alarm led
- 4-level password access to modify the setting
- Service report displaying all running hours and general conditions
- Memorized alarm history to facilitate the fault's analysis
- Remote full featured versions of the LCD terminal are available for a comfortable check and control of the unit over RS488 line.

Standard Configuration (furnished on basic unit)

Star Delta Compressors starter – For low inrush current and reduced starting torque.

Phase monitor – The phase monitor controls phase sequence and phase loss.

Evaporator connection water side Victaulic – Hydraulic joint with gasket for an easy and quick water connection.

Double Set Point version (CB) – Dual leaving glycol mixture temperature setpoints. The lower setpoint can go down to 0°C. This option needs 20mm thicked evaporator insulation (option on request).

1 pass condensers for SE ST units 211.1-251.1-293.1 and 424.2÷596.2.

2 passes condensers for SE ST units 111.1÷186.1 and 231.2÷385.2, and for XE ST units.

Hour run meter – Digital compressors hour run meter.

General fault relay – Contactor for the alarm warning.

Alarm from external device – Microprocessor is able to receive an alarm signal from an external device (pump, etc...). User can decide if this alarm signal will stop or not the unit.

Discharge line check valves

Options (on request)

Partial heat recovery – Enabled through a shell & tubes type sited between the compressor and the condenser, completely dedicated to the heat recovery. These allow hot water to be produced up to a maximum temperature of 58°C, and to have a very economic solution.

Evaporator electric heater – Electric heater controlled by a thermostat to protect the evaporator from freezing down to -28°C ambient temperature.

Compressor thermal overload relays - Safety devices against compressor motor overloading in addition to the normal protection envisaged by the electrical windings.

Amp and Volt Meter - Digital meters of unit drawn amperes and voltage values, installed on the electrical control panel.

Power factor correction - Installed on the electrical control panel to ensure it complies with the plant rules. (McQuay advises maximum 0,9).

Flow switch - Supplied separately to be wired and installed on the evaporator water piping (by the customer).

Suction line shut-off valves – Suction shut-off valve installed on the suction part of the compressor to facilitate maintenance operations.

Discharge line shut-off valves – Discharge shut-off valve installed on the discharge part of the compressor to facilitate maintenance operations.

Cu-Ni 90-10 condenser – To work with sea water the heat exchangers are fitted with Cu-Ni tubes and special protection inside the end covers.

Rubber type antivibration mounts - Supplied separately, these are positioned under the base of the unit for "floor" installation.

Sound proof cabinet - Made of sheet metal and internally insulated, the cabinet is "integral kind" (around the whole chiller, not only around the compressors) to reach the best performance in noise reduction.

Current Limit / Display – This option allows to monitor the chiller absorbed current with possibility to set a limit value. This option excludes the Demand Limit.

20mm thicked evaporator insulation – Useful in really heavy operating conditions.

2 passes condensers working with 9÷12 °C water ΔT for SE ST units 211.1-251.1-293.1 and 424.2÷596.2

4 passes condensers working with 9÷12 °C water ΔT for SE ST units 111.1÷186.1 and 231.2÷385.2, and for XE ST units

Witness tests - The units are normally tested at the test bench prior to the shipment. On request, a second test can be carried out, at customer's presence, in accordance with the procedures indicated on the test form. (Not available for units with Glycol mixtures).

Soft start – Electronic starting device to prevent mechanical stress of the motor. An overload protection is included (no need of compressors thermal relays).

Over / Under Voltage – Phase monitor to control the minimum and maximum voltage value that the user can set.

Supervising systems (on request)

PlantVisor™:

Solution for tele-maintenance and supervisory

MicroTech II C Plus can be monitored locally or via modem or GSM by PlantVisor™ supervision program.

PlantVisor™ is compatible with all Windows based systems.

It allows the followings functions:

- Unit status monitoring
- Circuits status monitoring
- Set-points modification
- Alarms display.

MicroTech II C Plus remote control

MicroTech II C Plus is able to communicate to BMS (Building Management System) based on the most common protocols as:

- CARELNative
- ModbusRTU
- LonWorks, now also based on the international 8040 Standard Chiller Profile and LonMark Technology
- BacNet BTP certifief over IP and MS/TP (class 4)
- Ethernet TCP/IP and SNMP.

Chiller Sequencing

MicroTech II control family allows an easy plug-in sequencing technology based on digital or serial field panel

MCS (McQuay Chiller Sequences)

Digital Step Inverter to sequence and rotate up to 11 chillers, based on 1 or 2 configurable input sensors. A very interesting low level full configurable digital field system. Monitorable by Plant Visor.

CSC II (Chiller System Controller II)

Serial sequences for up to 5 MTII chillers. Full featured field serial device to sequence, optimize and monitor a little group of McQuay chillers (check your catalogue for compatibility and features). Monitorable by Plant Visor.

NOMENCLATURE

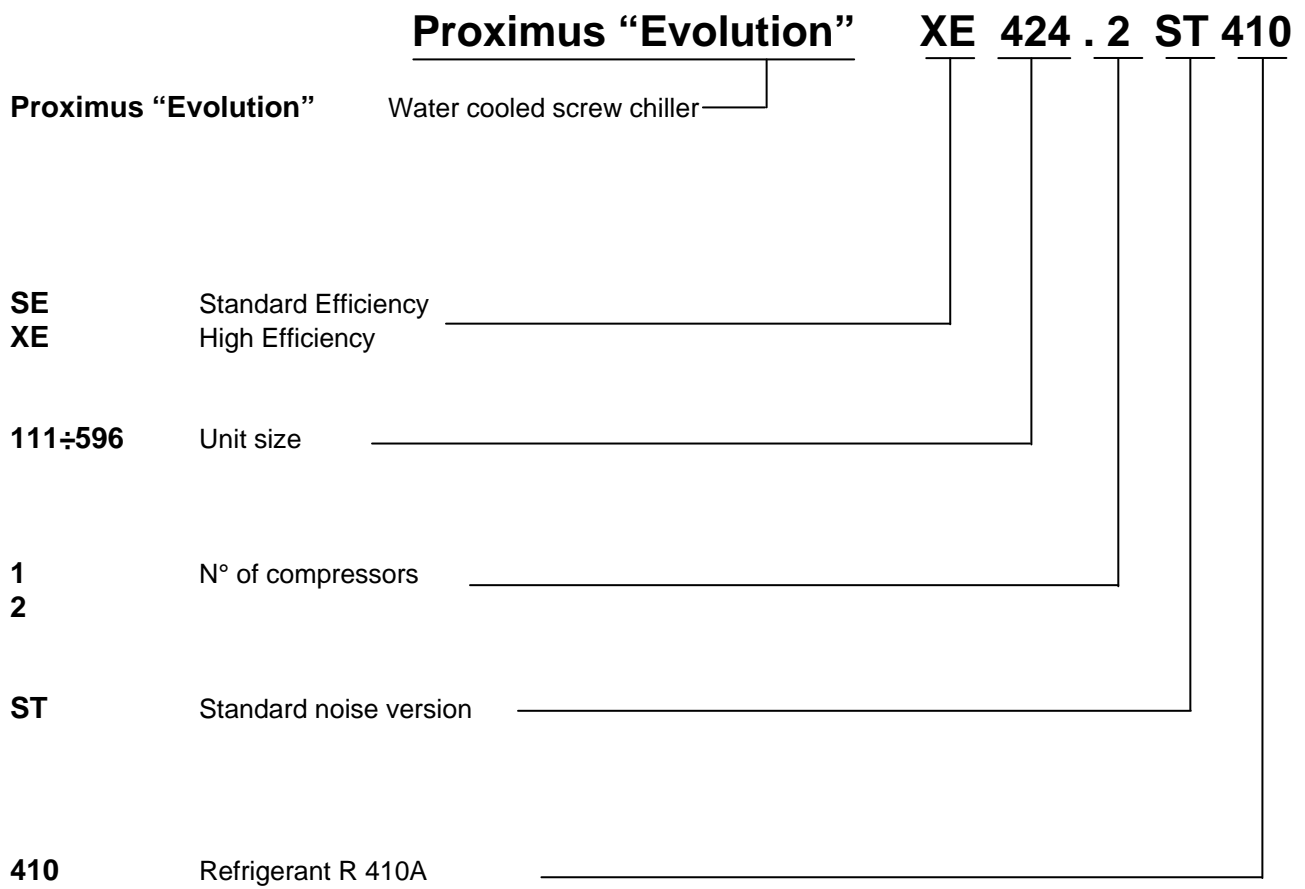

TECHNICAL SPECIFICATIONS

Technical data – Proximus “Evolution” SE ST

TECHNICAL SPECIFICATIONS			PROXIMUS “EVOLUTION” SE ST		111.1	135.1	164.1	186.1	211.1
Capacity	Cooling	kW	388	474	574	651	742		
Capacity control	Type	Stepless							
	Minimum capacity	%	25	25	25	25	25		
Unit power input	Cooling	kW	87	106	130	148	170		
EER			4.44	4.46	4.40	4.41	4.37		
ESEER			4.95	4.98	4.97	4.97	4.72		
Casing	Colour	RAL7032							
	Material	Galvanized and painted steel sheet							
Dimensions	Unit	Height	mm	1850	1850	2000	2000	1846	
		Width	mm	1065	1065	1185	1185	1160	
		Depth	mm	3518	3518	3483	3483	3554	
Weight	Unit	kg	1666	1701	1954	2047	2248		
	Operating Weight	kg	1868	1911	2214	2343	2618		
Water heat exchanger Evaporator	Type	Shell and tubes							
	Water volume	l	124	118	176	170	274		
	Nominal water flow rate	Cooling	l/min	18.5	22.7	27.4	31.1	35.4	
	Nominal Water pressure drop	Cooling	kPa	49	65	45	48	55	
	Insulation material	Closet cell foam elastomer							
Water heat exchanger Condenser	Type	Shell and tubes							
	Number of condensers	No.	1	1	1	1	1		
	Water volume	l	79	92	84	126	97		
	Nominal water flow rate	Cooling	l/min	22.9	27.9	33.9	38.5	43.9	
	Nominal Water pressure drop	Cooling	kPa	60	64	68	66	16	
Insulation Material	Expanded elastomer								
Compressor	Type	Semi-hermet. single screw compr.							
	Oil charge	l	16	16	16	16	16		
	Quantity		1	1	1	1	1		
Sound level	Sound Power	Cooling	dBA	100.2	101.1	102.3	102.3	101.5	
	Sound Pressure	Cooling	dBA	82	83	84	84	83	
Refrigerant circuit	Refrigerant type		R410A	R410A	R410A	R410A	R410A		
	Refrigerant charge	kg	80	80	90	90	100		
	N. of circuits		1	1	1	1	1		
Piping connections	Evaporator water inlet/outlet	mm	168.3	168.3	219.1	219.1	219.1		
Pipinogconnections	Condenser water inlet/outlet	in	5"	5"	6"	6"	6"		
Safety devices	High pressure (pressure switch)								
Safety devices	Low pressure (pressure switch)								
Safety devices	Emergency stop								
Safety devices	High discharge temperature on the compressor								
Safety devices	Phase monitor								
Safety devices	Low pressure ratio								
Safety devices	High oil pressure drop								
Safety devices	Low oil pressure								
Notes	Cooling capacity, unit power input in cooling and EER are based on the following conditions: evaporator 12°C/7°C; condenser 30/ 35°C.								

TECHNICAL SPECIFICATIONS PROXIMUS "EVOLUTION" SE ST				231.2	251.1	254.2	279.2	293.1
Capacity	Cooling		kW	813	880	891	980	1028
Capacity control	Type			Stepless				
	Minimum capacity		%	25	25	12.5	12.5	12.5
Unit power input	Cooling		kW	175	206	194	213	245
EER				4.64	4.26	4.59	4.60	4.19
ESEER				5.37	4.60	5.36	5.34	4.53
Casing	Colour			RAL7032				
	Material			Galvanized and painted steel sheet				
Dimensions	Unit	Height	mm	2170	1846	2170	2170	1846
		Width	mm	1350	1160	1350	1350	1160
		Depth	mm	4974	3554	4974	4974	3554
Weight	Unit		kg	3442	2268	3471	3510	2291
	Operating Weight		kg	3943	2636	3985	4018	2646
Water heat exchanger Evaporator	Type			Shell and tubes				
	Water volume		l	344	266	344	325	251
	Nominal water flow rate	Cooling	l/min	38.8	42.0	42.6	46.8	49.1
	Nominal Water pressure drop	Cooling	kPa	54	50	64	59	57
	Insulation material			Closet cell foam elastomer				
Water heat exchanger Condenser	Type			Shell and tubes				
	Number of condensers		No.	2	1	2	2	1
	Water volume		l	1)79 2)79	102	1)79 2)92	1)92 2)92	104
	Nominal water flow rate	Cooling	l/min	1)23.8 2)23.8	52.3	1)23.8 2)28.5	1)28.7 2)28.7	61.3
	Nominal Water pressure drop	Nominal Water pressure drop	kPa	1)64 2)64	20	1)64 2)67	1)68 2)68	26
	Insulation Material			Expanded elastomer				
Compressor	Type			Semi-hermet. Single screw compr.				
	Oil charge		l	32	16	32	32	16
	Quantity			2	1	2	2	1
Sound level	Sound Power	Cooling	dBA	104.7	102.3	104.7	105.1	103.2
	Sound Pressure	Cooling	dBA	84	85	85	85	86
Refrigerant circuit	Refrigerant type			R410A	R410A	R410A	R410A	R410A
	Refrigerant charge		kg	1)85 2)85	100	1)85 2)85	1)85 2)85	100
	N. of circuits			2	1	2	2	1
Piping connections	Evaporator water inlet/outlet		mm	219.1	219.1	219.1	219.1	219.1
Piping connections	Condenser water inlet/outlet		in	5"	6"	5"	5"	6"
Safety devices	High pressure (pressure switch)							
Safety devices	Low pressure (pressure switch)							
Safety devices	Emergency stop							
Safety devices	High discharge temperature on the compressor							
Safety devices	Phase monitor							
Safety devices	Low pressure ratio							
Safety devices	High oil pressure drop							
Safety devices	Low oil pressure							
Notes	Cooling capacity, unit power input in cooling and EER are based on the following conditions: evaporator 12°C/7°C; condenser 30/ 35°C.							

TECHNICAL SPECIFICATIONS			PROXIMUS "EVOLUTION" SE ST		307.2	345.2	365.2	385.2	424.2
Capacity	Cooling	kW	1077	1210	1281	1352	1488		
Capacity control	Type	Stepless							
	Minimum capacity	%	12.5	12.5	12.5	12.5	12.5		
Unit power input	Cooling	kW	237	262	279	296	340		
EER			4.55	4.62	4.59	4.56	4.38		
ESEER			5.33	5.36	5.35	5.29	4.93		
Casing	Colour	RAL7032							
	Material	Galvanized and painted steel sheet							
Dimensions	Unit	Height	mm	2170	2170	2320	2320	2320	
		Width	mm	1350	1350	1350	1350	1350	
		Depth	mm	3518	3518	4968	4968	4916	
Weight	Unit	kg	3480	3742	3757	3772	4391		
	Operating Weight	kg	3916	4399	4422	4445	5005		
Water heat exchanger Evaporator	Type	Shell and tubes							
	Water volume	l	325	538	538	538	505		
	Nominal water flow rate	Cooling	l/min	51.5	57.8	61.2	64.6	71.0	
	Nominal Water pressure drop	Cooling	kPa	70	45	50	55	60	
	Insulation material	Closet cell foam elastomer							
Water heat exchanger Condenser	Type	Shell and tubes							
	Number of condensers	No.	2	2	2	2	2		
	Water volume	l	1)52	1)60	1)60	1)68	1)54		
			2)60	2)60	2)68	2)68	2)54		
	Nominal water flow rate	Cooling	l/min	1)28.7 2)34.5	1)35.4 2)35.4	1)35.4 2)39.7	1)39.7 2)39.7	1)44.0 2)44.0	
	Nominal Water pressure drop	Nominal Water pressure drop	kPa	1)68 2)70	1)73 2)73	1)73 2)70	1)70 2)70	1)17 2)17	
Insulation Material	Expanded elastomer								
Compressor	Type	Semi-hermet. Single screw compr.							
	Oil charge	l	32	32	32	32	32		
	Quantity	2 2 2 2 2							
Sound level	Sound Power	Cooling	dBA	104.7	105.2	106.5	106.5	105.8	
	Sound Pressure	Cooling	dBA	86	87	87	87	86	
Refrigerant circuit	Refrigerant type	R410A R410A R410A R410A R410A							
	Refrigerant charge	kg	1)95	1)100	1)100	1)100	1)130		
			2)95	2)100	2)100	2)100	2)130		
N. of circuits	2 2 2 2 2								
Piping connections	Evaporator water inlet/outlet	mm	219.1	273	273	273	273		
Piping connections	Condenser water inlet/outlet	in	6"	6"	6"	6"	6"		
Safety devices	High pressure (pressure switch)								
Safety devices	Low pressure (pressure switch)								
Safety devices	Emergency stop								
Safety devices	High discharge temperature on the compressor								
Safety devices	Phase monitor								
Safety devices	Low pressure ratio								
Safety devices	High oil pressure drop								
Safety devices	Low oil pressure								
Notes	Cooling capacity, unit power input in cooling and EER are based on the following conditions: evaporator 12°C/7°C; condenser 30/ 35°C.								

TECHNICAL SPECIFICATIONS			PROXIMUS "EVOLUTION" SE ST		462.2	508.2	549.2	596.2
Capacity	Cooling	kW	1620	1783	1928	2093		
Capacity control	Type		Stepless					
	Minimum capacity	%	12.5	12.5	12.5	12.5		
Unit power input	Cooling	kW	375	409	442	475		
EER			4.32	4.36	4.37	4.40		
ESEER			4.93	4.82	4.89	4.87		
Casing	Colour		RAL7032					
	Material		Galvanized and painted steel sheet					
Dimensions	Unit	Height	mm	2320	2320	2320	2320	
		Width	mm	1350	1350	1350	1350	
		Depth	mm	4916	4916	4916	4916	
Weight	Unit		kg	4396	4426	4535	4577	
	Operating Weight		kg	5012	5043	5212	5258	
Water heat exchanger Evaporator	Type		Shell and tubes					
	Water volume		l	505	495	539	527	
	Nominal water flow rate	Cooling	l/min	77.3	85.1	92.0	99.8	
	Nominal Water pressure drop	Cooling	kPa	70	89	99	123	
	Insulation material		Closed cell foam elastomer					
Water heat exchanger Condenser	Type		Shell and tubes					
	Number of condensers		No.	2	2	2	2	
	Water volume		l	1)54 2)57	1)61 2)61	1)61 2)77	1)77 2)77	
	Nominal water flow rate	Cooling	l/min	1)44.0 2)52.0	1)52.7 2)52.7	1)53.0 2)61.0	1)61.8 2)61.8	
	Nominal Water pressure drop	Nominal Water pressure drop	kPa	1)17 2)19	1)17 2)17	1)17 2)15	1)15 2)15	
	Insulation Material		Expanded elastomer					
	Compressor	Type		Semi-hermet. single screw compr.				
Oil charge		l	32	32	32	32		
Quantity			2	2	2	2		
Sound level	Sound Power	Cooling	dBA	106.2	106.6	107.1	107.5	
	Sound Pressure	Cooling	dBA	87	87	88	88	
Refrigerant circuit	Refrigerant type		R-410A	R-410A	R-410A	R-410A		
	Refrigerant charge		kg	1)130 2)130	1)130 2)130	1)130 2)130	1)130 2)130	
	N. of circuits			2	2	2	2	
Piping connections	Evaporator water inlet/outlet		mm	273	273	273	273	
Piping connections	Condenser water inlet/outlet		in	6"	6"	6"	6"	
Safety devices	High pressure (pressure switch)							
Safety devices	Low pressure (pressure switch)							
Safety devices	Emergency stop							
Safety devices	High discharge temperature on the compressor							
Safety devices	Phase monitor							
Safety devices	Low pressure ratio							
Safety devices	High oil pressure drop							
Safety devices	Low oil pressure							
Notes	Cooling capacity, unit power input in cooling and EER are based on the following conditions: evaporator 12°C/7°C; condenser 30/35°C.							

Electrical data – Proximus “Evolution” SE ST

ELECTRICAL SPECIFICATIONS			PROXIMUS “EVOLUTION” SE ST		111.1	135.1	164.1	186.1	211.1
Power Supply	Phase				3~	3~	3~	3~	3~
	Frequency		Hz		50	50	50	50	50
	Voltage		V		400	400	400	400	400
	Voltage Tolerance	Minimum	%		-10%	-10%	-10%	-10%	-10%
		Maximum	%		+10%	+10%	+10%	+10%	+10%
Unit	Maximum starting current		A		455	455	455	455	656
	Nominal running current cooling		A		149	176	211	238	275
	Maximum running current		A		179	214	260	294	325
	Maximum current for wires sizing		A		197	235	286	324	357
Compressor	Phase				3~	3~	3~	3~	3~
	Voltage		V		400	400	400	400	400
	Voltage Tolerance	Minimum	%		-10%	-10%	-10%	-10%	-10%
		Maximum	%		+10%	+10%	+10%	+10%	+10%
	Maximum running current		A		189	225	274	310	325
Starting method			Open Star-Delta						
Notes	Allowed voltage tolerance $\pm 10\%$. Voltage unbalance between phases must be within $\pm 3\%$.								
	Nominal current in cooling mode is referred to installation with 25kA short circuit current and is based on the following conditions: evaporator 12°C/7°C; ambient 35°C.								
	Maximum starting current: starting current of biggest compressor + 75% of maximum current of the other compressor.								
	Maximum current for wires sizing: (compressors full load ampere) x 1,1.								
	Recommended fuses (IEC 269-2: 1.6 times largest compressor fuse size)								

ELECTRICAL SPECIFICATIONS			PROXIMUS “EVOLUTION” SE ST		231.2	251.1	254.2	279.2	293.1
Power Supply	Phase				3~	3~	3~	3~	3~
	Frequency		Hz		50	50	50	50	50
	Voltage		V		400	400	400	400	400
	Voltage Tolerance	Minimum	%		-10%	-10%	-10%	-10%	-10%
		Maximum	%		+10%	+10%	+10%	+10%	+10%
Unit	Maximum starting current		A		610	656	638	638	656
	Nominal running current cooling		A		289	330	325	352	386
	Maximum running current		A		358	381	393	428	445
	Maximum current for wires sizing		A		416	419	432	470	489
Compressor	Phase				3~	3~	3~	3~	3~
	Voltage		V		400	400	400	400	400
	Voltage Tolerance	Minimum	%		-10%	-10%	-10%	-10%	-10%
		Maximum	%		+10%	+10%	+10%	+10%	+10%
	Maximum running current		A		1)189 2)189	388	1)189 2)225	1)225 2)225	458
Starting method			Open Star-Delta						
Notes	Allowed voltage tolerance $\pm 10\%$. Voltage unbalance between phases must be within $\pm 3\%$.								
	Nominal current in cooling mode is referred to installation with 25kA short circuit current and is based on the following conditions: evaporator 12°C/7°C; ambient 35°C.								
	Maximum starting current: starting current of biggest compressor + 75% of maximum current of the other compressor.								
	Maximum current for wires sizing: (compressors full load ampere) x 1,1.								
	Recommended fuses (IEC 269-2: 1.6 times largest compressor fuse size)								

ELECTRICAL SPECIFICATIONS			PROXIMUS "EVOLUTION" SE ST		307.2	345.2	365.2	385.2	424.2
Power Supply	Phase			3~	3~	3~	3~	3~	3~
	Frequency		Hz	50	50	50	50	50	50
	Voltage		V	400	400	400	400	400	400
	Voltage Tolerance	Minimum	%	-10%	-10%	-10%	-10%	-10%	-10%
		Maximum	%	+10%	+10%	+10%	+10%	+10%	+10%
Unit	Maximum starting current		A	638	676	705	705	933	
	Nominal running current cooling		A	387	424	450	477	551	
	Maximum running current		A	474	522	556	589	650	
	Maximum current for wires sizing		A	522	574	611	648	715	
Compressor	Phase			3~	3~	3~	3~	3~	
	Voltage		V	400	400	400	400	400	
	Voltage Tolerance	Minimum	%	-10%	-10%	-10%	-10%	-10%	
		Maximum	%	+10%	+10%	+10%	+10%	+10%	
	Maximum running current		A	1)225 2)274	1)274 2)274	1)274 2)310	1)310 2)310	1)325 2)325	
	Starting method		Open Star-Delta						
Notes	Allowed voltage tolerance $\pm 10\%$. Voltage unbalance between phases must be within $\pm 3\%$.								
	Nominal current in cooling mode is referred to installation with 25kA short circuit current and is based on the following conditions: evaporator 12°C/7°C; ambient 35°C.								
	Maximum starting current: starting current of biggest compressor + 75% of maximum current of the other compressor.								
	Maximum current for wires sizing: (compressors full load ampere) x 1,1.								
	Recommended fuses (IEC 269-2: 1.6 times largest compressor fuse size)								

ELECTRICAL SPECIFICATIONS			PROXIMUS "EVOLUTION" SE ST		462.2	508.2	549.2	596.2	
Power Supply	Phase			3~	3~	3~	3~	3~	
	Frequency		Hz	50	50	50	50	50	
	Voltage		V	400	400	400	400	400	
	Voltage Tolerance	Minimum	%	-10%	-10%	-10%	-10%	-10%	
		Maximum	%	+10%	+10%	+10%	+10%	+10%	
Unit	Maximum starting current		A	984	984	1035	1035		
	Nominal running current cooling		A	604	654	701	749		
	Maximum running current		A	706	764	824	886		
	Maximum current for wires sizing		A	778	840	906	975		
Compressor	Phase			3~	3~	3~	3~		
	Voltage		V	400	400	400	400		
	Voltage Tolerance	Minimum	%	-10%	-10%	-10%	-10%		
		Maximum	%	+10%	+10%	+10%	+10%		
	Maximum running current		A	1)325 2)388	1)388 2)388	1)388 2)458	1)458 2)458		
	Starting method		Open Star-Delta						
Notes	Allowed voltage tolerance $\pm 10\%$. Voltage unbalance between phases must be within $\pm 3\%$.								
	Nominal current in cooling mode is referred to installation with 25kA short circuit current and is based on the following conditions: evaporator 12°C/7°C; ambient 35°C.								
	Maximum starting current: starting current of biggest compressor + 75% of maximum current of the other compressor.								
	Maximum current for wires sizing: (compressors full load ampere) x 1,1.								
	Recommended fuses (IEC 269-2: 1.6 times largest compressor fuse size)								

Technical data – Proximus “Evolution” XE ST

TECHNICAL SPECIFICATIONS		PROXIMUS “EVOLUTION” XE ST			111.1	135.1	164.1	186.1	211.1
Capacity	Cooling	kW		431	527	653	740	818	
Capacity control	Type			Stepless					
	Minimum capacity	%		25	25	25	25	25	
Unit power input	Cooling	kW		87	105	128	146	162	
EER				4.97	5.03	5.09	5.07	5.05	
ESEER				5.58	5.61	5.69	5.67	5.64	
Casing	Colour			RAL7032					
	Material			Galvanized and painted steel sheet					
Dimensions	Unit	Height	mm	2007	2007	2007	2007	2000	
		Width	mm	1192	1192	1192	1266	1266	
		Depth	mm	3908	3908	3908	4055	4055	
Weight	Unit		kg	1812	1852	1888	2082	2388	
	Operating Weight		kg	2084	2134	2169	2502	2796	
Water heat exchanger Evaporator	Type			Shell and tubes					
	Water volume		l	220	213	200	334	325	
	Nominal water flow rate	Cooling	l/min	20.0	24.4	30.2	34.3	37.9	
	Nominal Water pressure drop	Cooling	kPa	56	69	72	64	57	
	Insulation material			Closet cell foam elastomer					
Water heat exchanger Condenser	Type			Shell and tubes					
	Number of condensers		No.	1	1	1	1	1	
	Water volume		l	52	69	81	86	83	
	Nominal water flow rate	Cooling	l/min	24.3	29.6	36.7	41.6	46.0	
	Nominal Water pressure drop	Nominal Water pressure drop	kPa	50	40	42	47	60	
Insulation Material			Expanded elastomer						
Compressor	Type			Semi-hermet. single screw compr.					
	Oil charge		l	16	16	16	16	16	
	Quantity			1	1	1	1	1	
Sound level	Sound Power	Cooling	dBA	100.9	101.7	102.6	102.7	102.0	
	Sound Pressure	Cooling	dBA	82	83	84	84	83	
Refrigerant circuit	Refrigerant type			R410A	R410A	R410A	R410A	R410A	
	Refrigerant charge		kg	95	95	95	95	110	
	N. of circuits			1	1	1	1	1	
Piping connections	Evaporator water inlet/outlet		mm	219.1	219.1	219.1	219.1	219.1	
Piping connections	Condenser water inlet/outlet		in	6"	6"	6"	6"	6"	
Safety devices	High pressure (pressure switch)								
Safety devices	Low pressure (pressure switch)								
Safety devices	Emergency stop								
Safety devices	High discharge temperature on the compressor								
Safety devices	Phase monitor								
Safety devices	Low pressure ratio								
Safety devices	High oil pressure drop								
Safety devices	Low oil pressure								
Notes	Cooling capacity, unit power input in cooling and EER are based on the following conditions: evaporator 12°C/7°C; condenser 30/ 35°C.								

TECHNICAL SPECIFICATIONS			PROXIMUS "EVOLUTION" XE ST		251.1	279.2	293.1	307.2	345.2
Capacity	Cooling	kW	993	1059	1139	1182	1297		
Capacity control	Type	Stepless							
	Minimum capacity	%	25	12.5	25	12.5	12.5		
Unit power input	Cooling	kW	197	209	232	233	258		
EER			5.05	5.06	4.91	5.07	5.04		
ESEER			5.39	5.89	5.28	5.87	5.88		
Casing	Colour	RAL7032							
	Material	Galvanized and painted steel sheet							
Dimensions	Unit	Height	mm	2000	2320	2000	2320	2320	
		Width	mm	1450	1350	1450	1350	1350	
		Depth	mm	3945	4968	3945	4968	4968	
Weight	Unit	kg	2660	3892	2660	3924	3942		
	Operating Weight	kg	3289	4548	3289	4572	4581		
Water heat exchanger Evaporator	Type	Shell and tubes							
	Water volume	l	538	587	538	575	563		
	Nominal water flow rate	Cooling	l/min	46.0	49.1	52.7	54.8	60.1	
	Nominal Water pressure drop	Cooling	kPa	54	54	69	64	55	
	Insulation material	Closet cell foam elastomer							
Water heat exchanger Condenser	Type	Shell and tubes							
	Number of condensers	No.	1	2	1	2	2		
	Water volume	l	91	1)69 2)70	91	1)73 2)76	1)76 2)76		
	Nominal water flow rate	Cooling	l/min	55.8	1)29.8 2)29.8	64.4	1)30.1 2)36.4	1)36.5 2)36.5	
	Nominal Water pressure drop	Nominal Water pressure drop	kPa	65	1)40 2)40	84	1)36 2)48	1)48 2)48	
	Insulation Material	Expanded elastomer							
Compressor	Type	Semi-hermet. single screw compr.							
	Oil charge	l	16	32	16	32	32		
	Quantity		1	2	1	2	2		
Sound level	Sound Power	Cooling	dBA	102.9	105.2	103.8	105.6	106.1	
	Sound Pressure	Cooling	dBA	84	86	85	86	87	
Refrigerant circuit	Refrigerant type	R410A							
	Refrigerant charge	kg	130	1)120 2)120	130	1)120 2)120	1)120 2)120		
	N. of circuits		1	2	1	2	2		
Piping connections	Evaporator water inlet/outlet	mm	273	273	273	273	273		
Piping connections	Condenser water inlet/outlet	in	6"	6"	6"	6"	6"		
Safety devices	High pressure (pressure switch)								
Safety devices	Low pressure (pressure switch)								
Safety devices	Emergency stop								
Safety devices	High discharge temperature on the compressor								
Safety devices	Phase monitor								
Safety devices	Low pressure ratio								
Safety devices	High oil pressure drop								
Safety devices	Low oil pressure								
Notes	Cooling capacity, unit power input in cooling and EER are based on the following conditions: evaporator 12°C/7°C; condenser 30/ 35°C.								

TECHNICAL SPECIFICATIONS			PROXIMUS "EVOLUTION" XE ST		365.2	385.2	424.2	462.2	508.2
Capacity	Cooling	kW	1397	1479	1605	1769	1901		
Capacity control	Type	Stepless							
	Minimum capacity	%	12.5	12.5	12.5	12.5	12.5		
Unit power input	Cooling	kW	275	292	321	356	390		
EER			5.08	5.07	4.99	4.96	4.87		
ESEER			5.98	5.93	5.67	5.71	5.48		
Casing	Colour	RAL7032							
	Material	Galvanized and painted steel sheet							
Dimensions	Unit	Height	mm	2320	2320	2320	2320	2320	
		Width	mm	1350	1350	1350	1350	1350	
		Depth	mm	4968	4968	4916	4916	4916	
Weight	Unit	kg	3975	3994	4536	4548	4616		
	Operating Weight	kg	4602	4631	5213	5214	5338		
Water heat exchanger Evaporator	Type	Shell and tubes							
	Water volume	l	551	551	495	484	535		
	Nominal water flow rate	Cooling	l/min	64.7	68.5	74.3	81.9	88.1	
	Nominal Water pressure drop	Cooling	kPa	68	75	70	89	91	
	Insulation material	Closet cell foam elastomer							
Water heat exchanger Condenser	Type	Shell and tubes							
	Number of condensers	No.	2	2	2	2	2		
	Water volume	l	1)75	1)86	1)91	1)91	1)91		
			2)86	2)86	2)91	2)91	2)91		
	Nominal water flow rate	Cooling	l/min	1)36.9	1)41.6	1)45.2	1)45.6	1)53.8	
				2)41.6	2)41.6	2)45.2	2)54.1	2)53.8	
Nominal Water pressure drop	Nominal Water pressure drop	kPa	1)49	1)47	1)44	1)45	1)61		
			2)47	2)47	2)44	2)61	2)61		
	Insulation Material	Expanded elastomer							
Compressor	Type	Semi-hermet. single screw compr.							
	Oil charge	l	32	32	32	32	32		
	Quantity	2							
Sound level	Sound Power	Cooling	dBA	106.1	106.5	105.8	106.2	106.6	
	Sound Pressure	Cooling	dBA	87	87	86	87	87	
Refrigerant circuit	Refrigerant type	R410A							
	Refrigerant charge	kg	1)120	1)120	1)130	1)130	1)130		
			2)120	2)120	2)130	2)130	2)130		
N. of circuits	2								
Piping connections	Evaporator water inlet/outlet	mm	273	273	273	273	273		
Pipino connections	Condenser water inlet/outlet	in	6"	6"	6"	6"	6"		
Safety devices	High pressure (pressure switch)								
Safety devices	Low pressure (pressure switch)								
Safety devices	Emergency stop								
Safety devices	High discharge temperature on the compressor								
Safety devices	Phase monitor								
Safety devices	Low pressure ratio								
Safety devices	High oil pressure drop								
Safety devices	Low oil pressure								
Notes	Cooling capacity, unit power input in cooling and EER are based on the following conditions: evaporator 12°C/7°C; condenser 30/ 35°C.								

TECHNICAL SPECIFICATIONS			PROXIMUS "EVOLUTION" XE ST		549.2	596.2			
Capacity	Cooling	kW	2061	2196					
Capacity control	Type	Stepless							
	Minimum capacity	%	12.5	12.5					
Unit power input	Cooling	kW	426	461					
EER			4.84	4.77					
ESEER			5.50	5.38					
Casing	Colour	RAL7032							
	Material	Galvanized and painted steel sheet							
Dimensions	Unit	Height	mm	2320	2320				
		Width	mm	1350	1350				
		Depth	mm	4916	4916				
Weight	Unit	kg	4629	4629					
	Operating Weight	kg	5339	5339					
Water heat exchanger Evaporator	Type	Shell and tubes							
	Water volume	l	527	527					
	Nominal water flow rate	Cooling	l/min	95.5	101.7				
	Nominal Water pressure drop	Cooling	kPa	113	127				
	Insulation material	Closet cell foam elastomer							
Water heat exchanger Condenser	Type	Shell and tubes							
	Number of condensers	No.	2	2					
	Water volume	l	1)91	1)91					
			2)91	2)91					
	Nominal water flow rate	Cooling	l/min	1)54.4 2)62.4	1)62.4 2)62.4				
Nominal Water pressure drop	Nominal Water pressure drop	kPa	1)54 2)79	1)79 2)79					
	Insulation Material	Expanded elastomer							
Compressor	Type	Semi-hermet. single screw compr.							
	Oil charge	l	32	32					
	Quantity		2	2					
Sound level	Sound Power	Cooling	dBA	107.1	107.5				
	Sound Pressure	Cooling	dBA	88	88				
Refrigerant circuit	Refrigerant type		R410A	R410A					
	Refrigerant charge	kg	130	130					
	N. of circuits		2	2					
Piping connections	Evaporator water inlet/outlet	mm	273	273					
Piping connections	Condenseer water inlet/outlet	in	6"	6"					
Safety devices	High pressure (pressure switch)								
Safety devices	Low pressure (pressure switch)								
Safety devices	Emergency stop								
Safety devices	High discharge temperature on the compressor								
Safety devices	Phase monitor								
Safety devices	Low pressure ratio								
Safety devices	High oil pressure drop								
Safety devices	Low oil pressure								
Notes	Cooling capacity, unit power input in cooling and EER are based on the following conditions: evaporator 12°C/7°C; condenser 30/ 35°C.								

Electrical data – Proximus “Evolution” XE ST

ELECTRICAL SPECIFICATIONS			PROXIMUS “EVOLUTION” XE ST		111.1	135.1	164.1	186.1	211.1
Power Supply	Phase			3~	3~	3~	3~	3~	3~
	Frequency		Hz	50	50	50	50	50	50
	Voltage		V	400	400	400	400	400	400
	Voltage Tolerance	Minimum	%	-10%	-10%	-10%	-10%	-10%	-10%
		Maximum	%	+10%	+10%	+10%	+10%	+10%	+10%
Unit	Maximum starting current		A	455	455	455	455	656	
	Nominal running current cooling		A	148	173	208	235	263	
	Maximum running current		A	178	211	256	291	316	
	Maximum current for wires sizing		A	195	232	282	320	348	
Compressor	Phase			3~	3~	3~	3~	3~	
	Voltage		V	400	400	400	400	400	
	Voltage Tolerance	Minimum	%	-10%	-10%	-10%	-10%	-10%	
		Maximum	%	+10%	+10%	+10%	+10%	+10%	
	Maximum running current		A	189	225	274	310	325	
Starting method			Open Star-Delta						
Notes	Allowed voltage tolerance $\pm 10\%$. Voltage unbalance between phases must be within $\pm 3\%$.								
	Nominal current in cooling mode is referred to installation with 25kA short circuit current and is based on the following conditions: evaporator 12°C/7°C; ambient 35°C.								
	Maximum starting current: starting current of biggest compressor + 75% of maximum current of the other compressor.								
	Maximum current for wires sizing: (compressors full load ampere) x 1,1.								
	Recommended fuses (IEC 269-2: 1.6 times largest compressor fuse size)								

ELECTRICAL SPECIFICATIONS			PROXIMUS “EVOLUTION” XE ST		251.1	279.2	293.1	307.2	
Power Supply	Phase			3~	3~	3~	3~	3~	
	Frequency		Hz	50	50	50	50	50	
	Voltage		V	400	400	400	400	400	
	Voltage Tolerance	Minimum	%	-10%	-10%	-10%	-10%	-10%	
		Maximum	%	+10%	+10%	+10%	+10%	+10%	
Unit	Maximum starting current		A	656	636	656	674		
	Nominal running current cooling		A	315	347	367	381		
	Maximum running current		A	376	422	442	467		
	Maximum current for wires sizing		A	414	464	486	514		
Compressor	Phase			3~	3~	3~	3~		
	Voltage		V	400	400	400	400		
	Voltage Tolerance	Minimum	%	-10%	-10%	-10%	-10%		
		Maximum	%	+10%	+10%	+10%	+10%		
	Maximum running current		A	388	1)225 2)225	458	1)225 2)274		
Starting method			Open Star-Delta						
Notes	Allowed voltage tolerance $\pm 10\%$. Voltage unbalance between phases must be within $\pm 3\%$.								
	Nominal current in cooling mode is referred to installation with 25kA short circuit current and is based on the following conditions: evaporator 12°C/7°C; ambient 35°C.								
	Maximum starting current: starting current of biggest compressor + 75% of maximum current of the other compressor.								
	Maximum current for wires sizing: (compressors full load ampere) x 1,1.								
	Recommended fuses (IEC 269-2: 1.6 times largest compressor fuse size)								

ELECTRICAL SPECIFICATIONS			PROXIMUS "EVOLUTION" XE ST		345.2	365.2	385.2	424.2
Power Supply	Phase			3~	3~	3~	3~	
	Frequency		Hz	50	50	50	50	
	Voltage		V	400	400	400	400	
	Voltage Tolerance	Minimum	%	-10%	-10%	-10%	-10%	
Maximum		%	+10%	+10%	+10%	+10%		
Unit	Maximum starting current		A	674	702	702	925	
	Nominal running current cooling		A	417	417	444	522	
	Maximum running current		A	514	514	548	629	
	Maximum current for wires sizing		A	566	603	639	692	
Compressor	Phase			3~	3~	3~	3~	
	Voltage		V	400	400	400	400	
	Voltage Tolerance	Minimum	%	-10%	-10%	-10%	-10%	
		Maximum	%	+10%	+10%	+10%	+10%	
	Maximum running current		A	1)274 2)274	1)274 2)310	1)310 2)310	1)325 2)325	
	Starting method			Open Star-Delta				
Notes	Allowed voltage tolerance $\pm 10\%$. Voltage unbalance between phases must be within $\pm 3\%$.							
	Nominal current in cooling mode is referred to installation with 25kA short circuit current and is based on the following conditions: evaporator 12°C/7°C; ambient 35°C.							
	Maximum starting current: starting current of biggest compressor + 75% of maximum current of the other compressor.							
	Maximum current for wires sizing: (compressors full load ampere) x 1,1.							
	Recommended fuses (IEC 269-2: 1.6 times largest compressor fuse size)							

ELECTRICAL SPECIFICATIONS			PROXIMUS "EVOLUTION" XE ST		462.2	508.2	549.2	596.2
Power Supply	Phase			3~	3~	3~	3~	
	Frequency		Hz	50	50	50	50	
	Voltage		V	400	400	400	400	
	Voltage Tolerance	Minimum	%	-10%	-10%	-10%	-10%	
Maximum		%	+10%	+10%	+10%	+10%		
Unit	Maximum starting current		A	979	979	1032	1032	
	Nominal running current cooling		A	575	627	678	729	
	Maximum running current		A	689	749	814	877	
	Maximum current for wires sizing		A	758	824	895	965	
Compressor	Phase			3~	3~	3~	3~	
	Voltage		V	400	400	400	400	
	Voltage Tolerance	Minimum	%	-10%	-10%	-10%	-10%	
		Maximum	%	+10%	+10%	+10%	+10%	
	Maximum running current		A	1)325 2)388	1)388 2)388	1)388 2)458	1)458 2)458	
	Starting method			Open Star-Delta				
Notes	Allowed voltage tolerance $\pm 10\%$. Voltage unbalance between phases must be within $\pm 3\%$.							
	Nominal current in cooling mode is referred to installation with 25kA short circuit current and is based on the following conditions: evaporator 12°C/7°C; ambient 35°C.							
	Maximum starting current: starting current of biggest compressor + 75% of maximum current of the other compressor.							
	Maximum current for wires sizing: (compressors full load ampere) x 1,1.							
	Recommended fuses (IEC 269-2: 1.6 times largest compressor fuse size)							

NOISE LEVELS

Sound pressure level Proximus “Evolution” SE ST

Unit size	Sound pressure level at 1 m from the unit in semispheric free field (rif. 2×10^{-5} Pa)									Power
	63 Hz	125 Hz	250 Hz	500 Hz	1000 Hz	2000 Hz	4000 Hz	8000 Hz	dB(A)	dB(A)
111.1	55.1	59.4	71.6	84.1	71.9	72.5	58.5	53.2	82.2	100.2
135.1	55.9	60.2	72.4	84.9	72.7	73.3	59.3	54	83.0	101.2
164.1	56.8	61.1	73.3	85.8	73.6	74.2	60.2	54.9	83.9	102.3
186.1	56.8	61.1	73.3	85.8	73.6	74.2	60.2	54.9	83.9	102.3
211.1	56,1	60,4	72,6	85,1	72,9	73,5	59,5	54,2	83,2	101.5
231.2	56,9	61,2	73,4	85,9	73,7	74,3	60,3	55,0	84,0	104.7
251.1	57,8	62,1	74,3	86,8	74,6	75,2	61,2	55,9	84,9	102.3
254.2	58.1	62.4	74.6	87.1	74.9	75.5	61.5	56.2	85.2	104.7
279.2	58.1	62.4	74.6	87.1	74.9	75.5	61.5	56.2	85.2	105.1
293.1	58.5	62.8	75	87.5	75.3	75.9	61.9	56.6	85.6	103.2
307.2	58.9	63.2	75.4	87.9	75.7	76.3	62.3	57	86.0	104.7
345.2	59.4	63.7	75.9	88.4	76.2	76.8	62.8	57.5	86.5	105.2
365.2	59.8	64.1	76.3	88.8	76.6	77.2	63.2	57.9	86.9	106.5
385.2	59.8	64.1	76.3	88.8	76.6	77.2	63.2	57.9	86.9	106.5
424.2	59,1	63,4	75,6	88,1	75,9	76,5	62,5	57,2	86,2	105.8
462.2	59,5	63,8	76,0	88,5	76,3	76,9	62,9	57,6	86,6	106.2
508.2	59,9	64,2	76,4	88,9	76,7	77,3	63,3	58,0	87,0	106.6
549.2	60,4	64,7	76,9	89,4	77,2	77,8	63,8	58,5	87,5	107.1
596.2	60,8	65,1	77,3	89,8	77,6	78,2	64,2	58,9	87,9	107.5

Note: The values are according to ISO 3744 and are referred to: evaporator 12/7° C, condenser 30/35° C, full load operation.

Sound pressure level Proximus “Evolution” XE ST

Unit size	Sound pressure level at 1 m from the unit in semispheric free field (rif. 2×10^{-5} Pa)									Power
	63 Hz	125 Hz	250 Hz	500 Hz	1000 Hz	2000 Hz	4000 Hz	8000 Hz	dB(A)	dB(A)
111.1	55.1	59.4	71.6	84.1	71.9	72.5	58.5	53.2	82.2	100.9
135.1	55.9	60.2	72.4	84.9	72.7	73.3	59.3	54	83.0	101.7
164.1	56.8	61.1	73.3	85.8	73.6	74.2	60.2	54.9	83.9	102.6
186.1	56.8	61.1	73.3	85.8	73.6	74.2	60.2	54.9	83.9	102.7
211.1	56,1	60,4	72,6	85,1	72,9	73,5	59,5	54,2	83,2	102.0
251.1	56,9	61,2	73,4	85,9	73,7	74,3	60,3	55,0	84,0	102.9
279.2	58.5	62.8	75	87.5	75.3	75.9	61.9	56.6	85.6	105.2
293.1	57,8	62,1	74,3	86,8	74,6	75,2	61,2	55,9	84,9	103.8
307.2	58.9	63.2	75.4	87.9	75.7	76.3	62.3	57.0	86.0	105.6
345.2	59.4	63.7	75.9	88.4	76.2	76.8	62.8	57.5	86.5	106.1
365.2	59.8	64.1	76.3	88.8	76.6	77.2	63.2	57.9	86.9	106.5
385.2	59.8	64.1	76.3	88.8	76.6	77.2	63.2	57.9	86.9	106.5
424.2	59,1	63,4	75,6	88,1	75,9	76,5	62,5	57,2	86,2	105.8
462.2	59,5	63,8	76,0	88,5	76,3	76,9	62,9	57,6	86,6	106.2
508.2	59,9	64,2	76,4	88,9	76,7	77,3	63,3	58,0	87,0	106.6
549.2	60,4	64,7	76,9	89,4	77,2	77,8	63,8	58,5	87,5	107.1
596.2	60,8	65,1	77,3	89,8	77,6	78,2	64,2	58,9	87,9	107.5

Note: The values are according to ISO 3744 and are referred to: evaporator 12/7° C, condenser 30/35° C, full load operation.

Sound pressure correction factors for different distances SE ST-XE ST

Unit size	Distance (m)					
	1	5	10	15	20	25
111.1	0	-7.9	-12.7	-15.8	-18.1	-19.8
135.1	0	-7.9	-12.7	-15.8	-18.1	-19.8
164.1	0	-7.9	-12.7	-15.8	-18.1	-19.8
186.1	0	-7.9	-12.7	-15.8	-18.1	-19.8
211.1	0	-7.9	-12.7	-15.8	-18.1	-19.8
231.2	0	-7.5	-12.2	-15.3	-17.5	-19.3
251.1	0	-7.9	-12.7	-15.8	-18.1	-19.8
254.2	0	-7.5	-12.2	-15.3	-17.5	-19.3
279.2	0	-7.5	-12.2	-15.3	-17.5	-19.3
293.1	0	-7.9	-12.7	-15.8	-18.1	-19.8
307.2	0	-7.5	-12.2	-15.3	-17.5	-19.3
345.2	0	-7.5	-12.2	-15.3	-17.5	-19.3
365.2	0	-7.5	-12.2	-15.3	-17.5	-19.3
385.2	0	-7.5	-12.2	-15.3	-17.5	-19.3
424.2	0	-7.5	-12.2	-15.3	-17.5	-19.3
462.2	0	-7.5	-12.2	-15.3	-17.5	-19.3
508.2	0	-7.5	-12.2	-15.3	-17.5	-19.3
549.2	0	-7.5	-12.2	-15.3	-17.5	-19.3
596.2	0	-7.5	-12.2	-15.3	-17.5	-19.3

Note: The values are dB(A) (pressure level).

OPERATING FIELD

Operating limits Proximus "Evolution" SE ST - XE ST

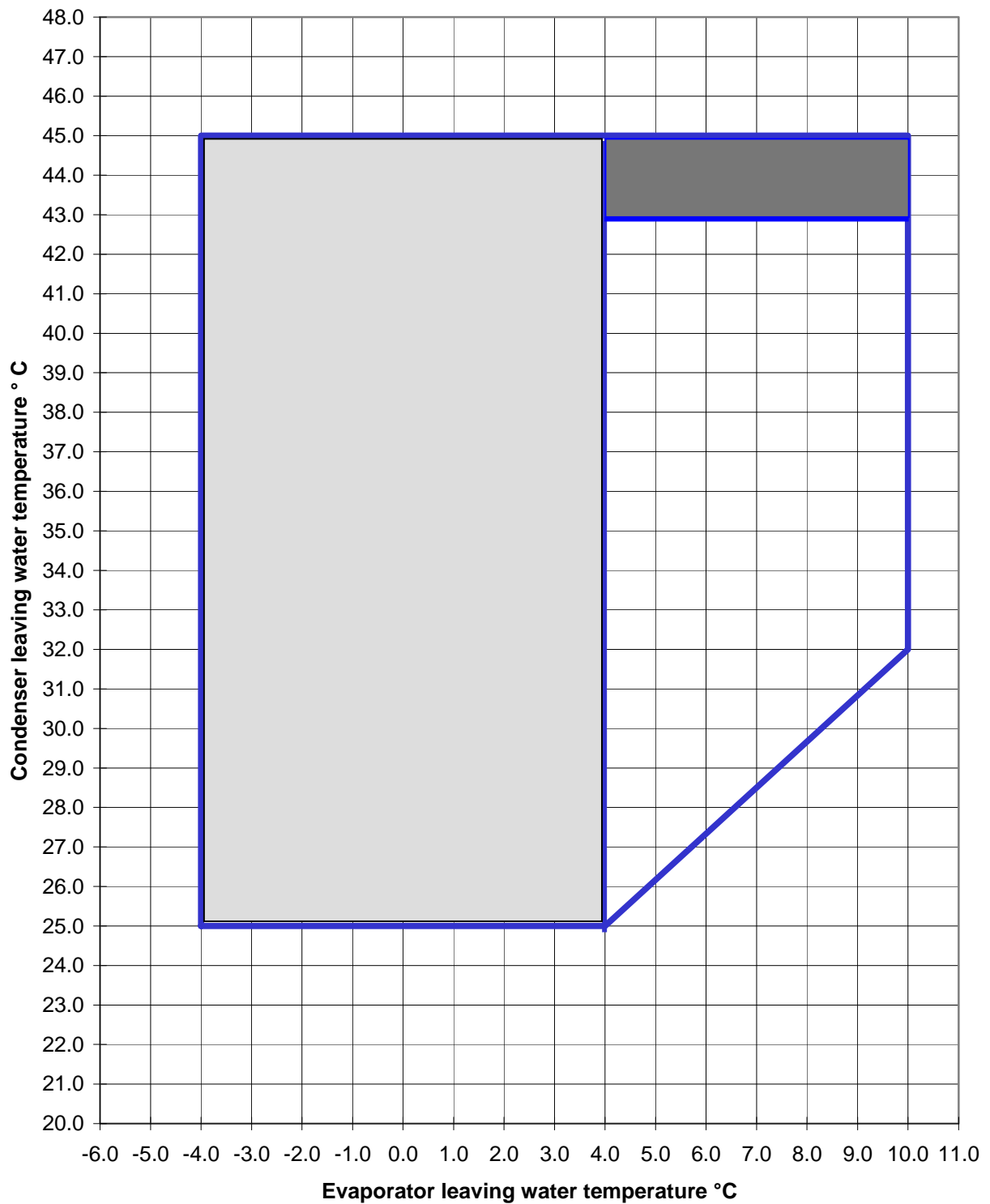

 The use of glycol is necessary

 In this area SE ST units 211.1-251.1-293.1-424.2-462.2-508.2-549.2-596.2 work with partialised compressor.

Operating limits

Proximus "Evolution" 111.1 ÷ 596.2		R-410A
Max evaporator water ΔT	°C	6
Min evaporator water ΔT	°C	4
Max condenser water ΔT	°C	8
Min condenser water ΔT	°C	4

Evaporator fouling factors

Fouling factors $m^2\text{°C} / \text{kW}$	Cooling capacity correction factor	Power input correction factor	EER correction factor
0,0176	1,000	1,000	1,000
0,0440	0,978	0,986	0,992
0,0880	0,957	0,974	0,983
0,1320	0,938	0,962	0,975

Condenser fouling factors

Fouling factors $m^2\text{°C} / \text{kW}$	Cooling capacity correction factor	Power input correction factor	EER correction factor
0,044	1,000	1,000	1,000
0,088	0,990	1,018	0,973
0,132	0,981	1,036	0,945

Ethylene glycol and low ambient temperature correction factors

Air ambient temperature °C	-3	-8	-15	-23	-35
% of ethylene glycol by weight	10	20	30	40	50
Cooling capacity correction factor	0,991	0,982	0,972	0,961	0,946
Power input correction factor	0,996	0,992	0,986	0,976	0,966
Flow rate correction factor	1,013	1,040	1,074	1,121	1,178
Water pressure drops correction factor	1,070	1,129	1,181	1,263	1,308

Low temperature operation performance factors

Ethylene glycol/water leaving temperature °C	3	2	0	-2	-4	-6	-8
Min. % of ethylene glycol	10	10	20	20	30	30	30
Cooling capacity correction factor	0,882	0,853	0,799	0,747	0,697	0,650	0,604
Power input compressors correction factor	0,977	0,971	0,960	0,947	0,934	0,919	0,903

Water content in cooling circuits

The cooled water distribution circuits should have a minimum water content to avoid excessive compressor's starts and stops.

In fact, each time the compressor starts up, an excessive quantity of oil goes from the compressor sump and simultaneously there is a rise in the temperature of the compressor motor's stator, due to the inrush current during the start-up. To prevent damage to the compressors, McQuay has envisaged the application of a device to limit frequent stops and restarts.

During the span of one hour there will be no more than 6 starts of the compressor. The plant side should therefore ensure that the overall water content allows a more constant functioning of the unit and consequently greater environmental comfort. The minimum installation water content envisaged should be calculated with a certain approximation using this simplified formula:

$$(1) \quad Q = 35,83 \times \frac{P \text{ (kW)}}{\Delta T (^{\circ}\text{C})} \times \frac{1}{N}$$

where:

Q = Minimum content of the plant expressed in litres

P = Cooling capacity of the plant expressed in kW

ΔT = Entering/leaving water temperature difference of the evaporator expressed in $^{\circ}\text{C}$

N = Number of compressors.

This should be the minimum quantity of water through the chiller in each operating condition, also when terminal hydronic units are switched off.

Therefore for a more accurate determination of the water quantity, it is advisable to contact the designer of the plant.

STANDARD RATINGS

PROXIMUS “EVOLUTION” 111.1÷ 231.2 SE ST

Unit size	Leaving chilled water temp. °C	ENTERING CONDENSER WATER TEMPERATURE (ΔT=5°C)									
		20		25		30		35		40	
		Cool. Cap. (kW)	Pow. Input (kW)	Cool. Cap. (kW)	Pow. Input (kW)	Cool. Cap. (kW)	Pow. Input (kW)	Cool. Cap. (kW)	Pow. Input (kW)	Cool. Cap. (kW)	Pow. Input (kW)
PRX EV 111.1	4	398.3	68.4	377.5	77.4	353.9	86.9	328.0	96.9	300.5	107.6
	5	410.0	68.5	389.1	77.6	365.1	87.1	338.8	97.1	310.8	107.8
	6	422.0	68.6	400.8	77.7	376.4	87.2	349.8	97.2	321.3	107.9
	7	434.1	68.7	412.6	77.9	388.0	87.4	360.9	97.4	332.1	108.1
	8	446.5	68.8	424.5	78.0	399.7	87.5	372.2	97.6	343.0	108.2
	9	459.0	68.9	436.7	78.1	411.5	87.7	383.7	97.7	354.1	108.4
	10	471.8	69.0	449.0	78.2	423.4	87.8	395.4	97.9	365.3	108.5
PRX EV 135.1	4	486.6	83.2	461.4	94.2	432.7	105.7	401.3	117.9	367.9	131.0
	5	500.7	83.4	475.4	94.4	446.4	105.9	414.4	118.1	380.5	131.1
	6	515.0	83.5	489.7	94.5	460.1	106.1	427.8	118.3	393.4	131.3
	7	529.5	83.6	503.8	94.7	474.1	106.3	441.3	118.5	406.4	131.5
	8	544.3	83.7	518.0	94.9	488.4	106.5	455.1	118.7	419.7	131.7
	9	559.3	83.8	532.6	95.0	502.4	106.6	469.0	118.9	433.1	131.9
	10	574.5	83.9	547.3	95.2	516.7	106.8	483.2	119.1	446.8	132.1
PRX EV 164.1	4	589.3	102.2	559.2	115.6	524.9	129.7	487.3	144.8	447.2	160.9
	5	606.5	102.3	575.9	115.8	541.2	130.0	503.0	145.0	462.4	161.1
	6	624.1	102.5	592.9	116.0	557.7	130.2	519.0	145.2	477.8	161.3
	7	642.0	102.7	610.2	116.2	574.4	130.4	535.2	145.5	493.5	161.5
	8	660.1	102.8	627.8	116.4	591.3	130.7	551.7	145.7	509.4	161.8
	9	678.6	103.0	645.6	116.6	608.6	130.9	568.3	146.0	525.5	162.0
	10	697.4	103.1	663.8	116.8	626.1	131.1	585.2	146.2	541.9	162.2
PRX EV 186.1	4	668.2	115.8	634.2	131.0	595.2	147.1	552.3	164.1	506.8	182.5
	5	687.7	116.0	653.1	131.3	613.9	147.3	570.3	164.4	524.0	182.7
	6	707.6	116.2	672.4	131.5	632.6	147.6	588.5	164.7	541.6	182.9
	7	727.8	116.4	691.9	131.7	651.5	147.9	607.1	164.9	559.5	183.2
	8	748.3	116.5	711.8	132.0	670.7	148.1	625.9	165.2	577.6	183.4
	9	769.2	116.7	732.0	132.2	690.2	148.4	644.7	165.5	596.0	183.7
	10	790.4	116.8	752.5	132.4	710.0	148.6	663.8	165.7	614.8	183.9
PRX EV 211.1	4	754.4	135.4	715.0	150.9	673.3	166.6	629.7	183.1	584.2	200.9
	5	778.5	136.3	738.4	151.9	695.8	167.7	651.2	184.2	604.6	202.1
	6	803.0	137.1	762.1	152.9	718.8	168.8	673.1	185.3	609.3	199.9
	7	828.0	137.9	786.3	153.8	742.1	169.7	695.5	186.4	613.3	197.4
	8	853.4	138.6	810.9	154.6	765.8	170.6	718.3	187.3	616.6	194.6
	9	879.1	139.1	836.0	155.2	789.9	171.3	741.4	188.1	619.0	191.4
	10	905.2	139.5	861.2	155.7	814.4	171.9	764.9	188.7	620.6	187.9
PRX EV 231.2	4	834.9	137.2	790.0	155.3	739.3	174.2	684.1	194.2	625.7	215.6
	5	860.7	137.4	814.9	155.6	763.3	174.6	707.2	194.6	647.6	215.9
	6	887.1	137.6	840.3	155.9	787.7	174.9	730.5	194.9	670.1	216.2
	7	913.9	137.8	866.2	156.1	812.5	175.2	754.3	195.2	693.0	216.5
	8	941.2	137.9	892.5	156.4	837.9	175.5	778.6	195.6	716.2	216.8
	9	968.9	138.1	919.4	156.6	863.7	175.8	803.4	195.9	739.8	217.2
	10	997.1	138.2	946.7	156.9	890.0	176.1	828.6	196.3	763.9	217.5

Notes: C.C. (cooling capacity) and P.I. (unit power input) are referred to 0,0176m² °C/kW evaporator fouling factor and 0,0440m² °C/kW condenser fouling factor. Rated conditions are for compressors running at nominal frequency. Shaded values are referred to part load operation.

PROXIMUS “EVOLUTION” 251.1÷ 345.2 SE ST

Unit size	Leaving chilled water temp. °C	ENTERING CONDENSER WATER TEMPERATURE (ΔT=5°C)									
		20		25		30		35		40	
		Cool. Cap. (kW)	Pow. Input (kW)	Cool. Cap. (kW)	Pow. Input (kW)	Cool. Cap. (kW)	Pow. Input (kW)	Cool. Cap. (kW)	Pow. Input (kW)	Cool. Cap. (kW)	Pow. Input (kW)
PRX EV 251.1	4	895.9	165.4	849.1	183.3	799.8	202.0	747.7	220.9	632.7	226.2
	5	924.0	166.5	876.4	184.6	826.1	203.5	772.9	222.5	636.1	223.4
	6	952.6	167.7	904.3	185.9	852.8	205.0	798.4	224.1	638.6	220.3
	7	981.8	168.7	932.4	187.2	880.1	206.4	824.5	225.6	640.1	216.9
	8	1011.4	169.8	960.9	188.5	907.7	207.8	851.0	227.1	640.6	213.2
	9	1041.3	170.8	990.0	189.6	935.6	209.1	877.9	228.5	647.3	210.8
	10	1071.5	171.7	1019.5	190.7	964.0	210.3	905.2	229.8	645.8	206.5
PRX EV 254.2	4	915.2	151.9	866.8	172.0	811.9	192.9	752.1	215.1	688.9	238.9
	5	943.1	152.2	893.7	172.3	837.9	193.3	777.0	215.5	712.7	239.2
	6	971.4	152.4	921.1	172.6	864.3	193.7	802.4	215.9	737.0	239.5
	7	1000.2	152.6	949.1	172.9	891.2	194.0	828.3	216.2	761.8	239.9
	8	1029.4	152.8	977.3	173.2	918.5	194.4	854.6	216.6	787.0	240.2
	9	1058.8	153.0	1006.0	173.5	946.4	194.7	881.4	217.0	812.6	240.6
	10	1088.5	153.1	1035.2	173.7	974.6	195.0	908.6	217.4	838.7	241.0
PRX EV 279.2	4	1007.1	166.8	953.4	188.7	892.8	211.7	826.7	236.1	757.0	262.2
	5	1037.8	167.0	983.2	189.1	921.5	212.2	854.3	236.5	783.3	262.6
	6	1068.9	167.3	1013.6	189.5	950.7	212.6	882.4	237.0	810.1	263.0
	7	1100.6	167.5	1044.2	189.8	980.4	213.0	911.0	237.4	837.5	263.3
	8	1132.8	167.8	1075.3	190.1	1010.8	213.4	940.0	237.8	865.4	263.7
	9	1165.4	168.0	1107.0	190.4	1041.3	213.7	969.6	238.2	893.8	264.1
	10	1198.6	168.1	1139.2	190.7	1072.4	214.1	999.8	238.6	922.6	264.5
PRX EV 293.1	4	1049.2	196.8	993.7	217.7	934.8	239.7	873.1	261.9	638.5	242.9
	5	1082.2	198.3	1025.4	219.4	965.6	241.7	902.6	263.9	638.2	238.5
	6	1115.8	199.8	1057.8	221.2	996.6	243.6	932.7	266.0	644.7	235.8
	7	1149.8	201.3	1090.7	222.9	1028.1	245.5	963.2	268.1	642.1	230.9
	8	1184.4	202.8	1124.1	224.7	1060.2	247.4	993.9	270.1	646.9	227.8
	9	1219.6	204.4	1157.9	226.4	1092.9	249.3	1025.1	272.1	650.9	224.6
	10	1255.4	205.9	1192.3	228.1	1125.9	251.2	1056.7	274.1	654.1	221.1
PRX EV 307.2	4	1105.9	185.5	1048.3	209.9	982.9	235.6	911.5	262.8	835.8	291.9
	5	1139.0	185.8	1080.3	210.3	1013.9	236.0	941.4	263.2	864.4	292.3
	6	1172.0	186.1	1113.0	210.7	1045.4	236.5	971.8	263.7	893.6	292.7
	7	1205.5	186.4	1145.9	211.1	1077.4	236.9	1002.6	264.1	923.4	293.1
	8	1239.6	186.6	1178.9	211.4	1110.0	237.3	1034.0	264.6	953.6	293.6
	9	1274.1	186.8	1212.4	211.8	1143.0	237.7	1065.9	265.0	984.2	294.0
	10	1309.2	187.0	1246.5	212.1	1175.8	238.1	1098.3	265.5	1015.4	294.4
PRX EV 345.2	4	1243.7	205.0	1176.3	231.9	1100.6	260.2	1018.0	290.2	931.4	322.3
	5	1282.4	205.3	1213.6	232.4	1136.4	260.7	1052.5	290.7	964.2	322.8
	6	1320.3	205.6	1251.6	232.8	1172.9	261.2	1087.7	291.2	997.6	323.2
	7	1359.0	205.9	1290.0	233.3	1210.1	261.7	1123.4	291.7	1031.8	323.7
	8	1398.3	206.2	1328.0	233.7	1248.0	262.2	1159.7	292.2	1066.6	324.2
	9	1438.4	206.5	1366.7	234.0	1286.5	262.7	1196.7	292.8	1102.1	324.7
	10	1479.2	206.7	1406.0	234.4	1324.4	263.1	1234.4	293.3	1138.1	325.2

Notes: C.C. (cooling capacity) and P.I. (unit power input) are referred to 0,0176m² °C/kW evaporator fouling factor and 0,0440m² °C/kW condenser fouling factor. Rated conditions are for compressors running at nominal frequency. Shaded values are referred to part load operation.

PROXIMUS “EVOLUTION” 365.2÷ 549.2 SE ST

Unit size	Leaving chilled water temp. °C	ENTERING CONDENSER WATER TEMPERATURE (ΔT=5°C)									
		20		25		30		35		40	
		Cool. Cap. (kW)	Pow. Input (kW)	Cool. Cap. (kW)	Pow. Input (kW)	Cool. Cap. (kW)	Pow. Input (kW)	Cool. Cap. (kW)	Pow. Input (kW)	Cool. Cap. (kW)	Pow. Input (kW)
PRX EV 365.2	4	1315.5	218.6	1246.1	247.3	1167.1	277.5	1080.3	309.5	989.0	343.8
	5	1355.4	218.9	1284.6	247.8	1204.8	278.0	1116.6	310.0	1023.6	344.3
	6	1395.3	219.2	1323.8	248.2	1242.7	278.5	1153.6	310.6	1058.9	344.8
	7	1435.9	219.5	1363.6	248.7	1281.1	279.0	1191.2	311.1	1094.8	345.3
	8	1477.3	219.8	1403.5	249.1	1320.2	279.6	1229.1	311.6	1131.5	345.8
	9	1519.6	220.1	1444.0	249.5	1359.9	280.1	1267.3	312.2	1168.8	346.3
	10	1562.7	220.3	1485.5	249.9	1399.7	280.5	1306.2	312.7	1206.8	346.8
PRX EV 385.2	4	1387.3	232.1	1316.0	262.7	1233.6	294.8	1142.6	328.8	1046.5	365.3
	5	1428.4	232.5	1355.6	263.2	1273.3	295.3	1180.7	329.4	1083.0	365.8
	6	1470.2	232.8	1396.0	263.6	1312.5	295.9	1219.5	329.9	1120.2	366.3
	7	1512.7	233.2	1437.1	264.1	1352.1	296.4	1259.0	330.5	1157.9	366.8
	8	1556.2	233.5	1478.9	264.5	1392.4	296.9	1298.6	331.1	1196.3	367.4
	9	1600.8	233.7	1521.4	264.9	1433.4	297.4	1338.0	331.6	1235.5	367.9
	10	1646.2	234.0	1565.0	265.4	1475.1	297.9	1378.1	332.1	1275.5	368.4
PRX EV 424.2	4	1512.7	271.2	1433.9	302.3	1350.6	333.8	1263.2	366.8	1172.2	402.7
	5	1560.7	273.0	1480.7	304.4	1395.5	336.0	1306.3	369.1	1192.1	400.6
	6	1609.7	274.6	1528.1	306.3	1441.4	338.1	1350.1	371.3	1200.7	396.0
	7	1659.5	276.1	1576.3	308.0	1488.1	340.0	1394.8	373.3	1196.5	388.4
	8	1710.1	277.4	1625.4	309.5	1535.4	341.6	1440.3	375.1	1201.6	382.4
	9	1761.2	278.5	1675.3	310.8	1583.4	343.1	1486.6	376.6	1217.3	378.3
	10	1813.1	279.3	1725.7	311.8	1632.3	344.2	1533.5	377.7	1219.5	370.8
PRX EV 462.2	4	1647.5	300.1	1563.0	333.5	1473.3	368.0	1378.8	403.5	1226.0	428.3
	5	1698.9	302.1	1612.8	335.8	1521.5	370.6	1425.0	406.2	1239.5	424.5
	6	1750.9	304.0	1663.5	338.1	1570.6	373.0	1472.0	408.8	1246.5	419.2
	7	1803.8	305.8	1715.0	340.2	1620.3	375.4	1519.8	411.3	1251.8	413.3
	8	1857.4	307.5	1767.0	342.1	1670.8	377.6	1568.5	413.6	1262.3	408.3
	9	1911.1	309.0	1819.7	343.9	1721.9	379.6	1617.7	415.8	1264.2	401.0
	10	1965.5	310.2	1873.0	345.5	1773.5	381.4	1667.6	417.7	1271.7	394.8
PRX EV 508.2	4	1812.6	327.2	1719.9	362.9	1622.1	400.6	1517.9	438.6	1407.3	475.6
	5	1869.3	329.3	1774.8	365.4	1675.1	403.4	1568.9	441.6	1443.7	476.2
	6	1926.9	331.3	1830.6	367.8	1728.8	406.1	1620.8	444.6	1454.6	471.6
	7	1985.5	333.3	1887.3	370.2	1783.4	408.7	1673.4	447.5	1463.7	466.4
	8	2044.3	335.1	1944.9	372.4	1839.0	411.3	1726.6	450.2	1470.9	460.6
	9	2103.8	336.8	2003.3	374.5	1895.3	413.7	1780.7	452.8	1476.1	454.1
	10	2164.2	338.3	2061.7	376.4	1952.5	415.9	1835.6	455.2	1479.2	446.8
PRX EV 549.2	4	1958.7	353.5	1860.6	392.0	1755.9	432.9	1645.1	474.5	1528.7	515.2
	5	2018.9	355.7	1918.9	394.6	1812.7	435.8	1699.6	477.7	1574.8	517.3
	6	2079.8	357.8	1978.2	397.1	1870.0	438.8	1755.1	480.9	1602.1	515.5
	7	2141.2	359.9	2038.4	399.6	1928.1	441.6	1811.6	484.1	1635.1	514.6
	8	2203.2	361.9	2099.1	402.1	1987.2	444.4	1868.5	487.1	1652.3	510.4
	9	2265.7	363.8	2160.3	404.4	2047.0	447.1	1926.1	490.0	1652.0	502.5
	10	2329.0	365.6	2222.0	406.7	2107.3	449.7	1984.5	492.9	1657.2	495.5

Notes: C.C. (cooling capacity) and P.I. (unit power input) are referred to 0,0176m² °C/kW evaporator fouling factor and 0,0440m² °C/kW condenser fouling factor. Rated conditions are for compressors running at nominal frequency. Shaded values are referred to part load operation.

PROXIMUS “EVOLUTION” 596.2 SE ST

Unit size	Leaving chilled water temp. °C	ENTERING CONDENSER WATER TEMPERATURE (ΔT=5°C)									
		20		25		30		35		40	
		Cool. Cap. (kW)	Pow. Input (kW)	Cool. Cap. (kW)	Pow. Input (kW)	Cool. Cap. (kW)	Pow. Input (kW)	Cool. Cap. (kW)	Pow. Input (kW)	Cool. Cap. (kW)	Pow. Input (kW)
PRX EV 596.2	4	2125.8	380.6	2019.3	421.8	1905.9	466.0	1785.8	511.2	1661.7	555.5
	5	2190.7	382.9	2082.8	424.6	1967.1	469.2	1845.2	514.7	1718.5	559.2
	6	2256.1	385.2	2147.5	427.3	2029.4	472.3	1905.7	518.2	1776.4	562.8
	7	2322.6	387.4	2211.8	430.1	2092.7	475.5	1966.5	521.6	1835.2	566.5
	8	2390.2	389.7	2277.2	432.8	2157.0	478.6	2028.3	525.0	1831.6	557.9
	9	2459.1	391.9	2343.6	435.5	2221.0	481.7	2091.2	528.4	1841.1	551.8
	10	2529.0	394.2	2411.1	438.2	2286.0	484.7	2154.9	531.8	1848.5	545.0

Notes: C.C. (cooling capacity) and P.I. (unit power input) are referred to 0,0176m² °C/kW evaporator fouling factor and 0,0440m² °C/kW condenser fouling factor. Rated conditions are for compressors running at nominal frequency. Shaded values are referred to part load operation.

PROXIMUS “EVOLUTION” 111.1÷ 251.1 XE ST

Unit size	Leaving chilled water temp. °C	ENTERING CONDENSER WATER TEMPERATURE (ΔT=5°C)									
		20		25		30		35		40	
		Cool. Cap. (kW)	Pow. Input (kW)	Cool. Cap. (kW)	Pow. Input (kW)	Cool. Cap. (kW)	Pow. Input (kW)	Cool. Cap. (kW)	Pow. Input (kW)	Cool. Cap. (kW)	Pow. Input (kW)
PRX EV 111.1	4	442.0	67.7	418.1	76.8	391.1	86.3	361.8	96.3	330.9	106.9
	5	456.0	67.8	431.6	76.9	404.1	86.4	374.2	96.4	342.7	107.0
	6	470.2	67.9	445.4	77.0	417.3	86.5	386.8	96.5	354.6	107.2
	7	484.7	67.9	459.4	77.1	430.7	86.7	399.6	96.7	366.9	107.3
	8	499.6	67.9	473.7	77.2	444.5	86.8	412.8	96.8	379.5	107.4
	9	514.7	68.0	488.2	77.3	458.6	86.9	426.3	97.0	392.2	107.6
	10	530.0	68.0	503.1	77.4	472.8	87.0	440.0	97.1	405.3	107.7
PRX EV 135.1	4	539.3	81.8	510.7	92.8	478.0	104.3	442.5	116.5	405.1	129.5
	5	556.3	81.8	527.3	92.9	493.9	104.5	457.6	116.6	419.4	129.6
	6	573.6	81.9	543.8	93.0	510.1	104.6	473.2	116.8	434.1	129.8
	7	591.2	81.9	560.9	93.1	526.6	104.7	488.9	116.9	449.2	129.9
	8	609.2	81.9	578.2	93.2	543.3	104.8	505.1	117.1	464.5	130.0
	9	627.6	81.9	596.0	93.2	560.3	104.9	521.5	117.2	480.2	130.1
	10	646.1	81.9	614.0	93.3	577.6	105.0	538.2	117.3	496.3	130.3
PRX EV 164.1	4	668.3	100.1	632.7	113.7	592.6	127.8	548.9	142.7	502.8	158.7
	5	689.6	100.2	653.1	113.8	612.1	127.9	567.6	142.9	520.7	158.9
	6	711.3	100.3	674.0	113.9	632.1	128.1	586.7	143.1	538.8	159.0
	7	733.6	100.3	695.4	114.0	652.5	128.3	606.3	143.3	557.3	159.2
	8	756.2	100.3	717.2	114.1	673.4	128.4	626.1	143.4	576.3	159.3
	9	779.3	100.3	739.4	114.2	694.7	128.6	646.4	143.6	595.6	159.5
	10	802.7	100.3	762.1	114.3	716.6	128.7	667.2	143.8	615.4	159.7
PRX EV 186.1	4	758.7	114.0	718.0	129.3	672.1	145.3	622.2	162.3	569.8	180.4
	5	782.8	114.1	741.3	129.5	694.4	145.5	643.5	162.5	590.0	180.6
	6	807.3	114.1	765.0	129.6	717.2	145.7	665.3	162.7	610.7	180.8
	7	832.3	114.2	789.2	129.8	740.4	145.9	687.5	162.9	631.8	181.0
	8	857.9	114.2	813.7	129.9	764.1	146.1	710.2	163.1	653.3	181.2
	9	883.9	114.3	838.7	130.0	788.3	146.3	733.3	163.4	675.4	181.4
	10	910.4	114.3	864.4	130.1	812.8	146.5	756.8	163.6	697.8	181.6
PRX EV 211.1	4	826.2	128.0	786.2	144.0	743.6	159.9	698.5	176.2	651.3	193.6
	5	852.1	128.5	811.3	144.7	767.9	160.7	721.9	177.1	673.6	194.5
	6	878.5	129.0	837.0	145.3	792.6	161.4	745.7	177.9	696.4	195.3
	7	905.3	129.4	863.0	145.9	817.8	162.0	769.9	178.5	719.6	196.0
	8	932.6	129.7	889.5	146.3	843.5	162.5	794.6	179.1	743.1	196.6
	9	960.3	129.8	916.4	146.5	869.5	162.9	819.7	179.5	767.1	197.0
	10	988.4	129.8	943.8	146.6	896.0	163.0	845.1	179.7	791.6	197.2
PRX EV 251.1	4	1005.1	156.9	953.4	174.5	899.2	193.2	842.1	212.5	782.0	231.5
	5	1038.1	157.7	985.3	175.4	929.9	194.4	871.5	213.8	809.8	232.9
	6	1071.9	158.4	1017.8	176.4	961.1	195.5	901.4	215.1	838.2	234.3
	7	1106.2	159.0	1051.1	177.2	993.0	196.6	931.8	216.3	867.3	235.6
	8	1139.9	159.5	1084.9	178.0	1025.5	197.5	962.9	217.4	896.7	236.8
	9	1174.1	159.9	1118.7	178.6	1058.6	198.4	994.6	218.4	926.8	237.9
	10	1208.8	160.3	1152.3	179.2	1092.2	199.1	1026.7	219.2	957.4	238.9

Notes: C.C. (cooling capacity) and P.I. (unit power input) are referred to 0,0176m² °C/kW evaporator fouling factor and 0,0440m² °C/kW condenser fouling factor. Rated conditions are for compressors running at nominal frequency. Shaded values are referred to part load operation.

PROXIMUS “EVOLUTION” 279.2÷ 385.2 XE ST

Unit size	Leaving chilled water temp. °C	ENTERING CONDENSER WATER TEMPERATURE (ΔT=5°C)									
		20		25		30		35		40	
		Cool. Cap. (kW)	Pow. Input (kW)	Cool. Cap. (kW)	Pow. Input (kW)	Cool. Cap. (kW)	Pow. Input (kW)	Cool. Cap. (kW)	Pow. Input (kW)	Cool. Cap. (kW)	Pow. Input (kW)
PRX EV 279.2	4	1085.5	163.6	1027.3	185.7	961.5	208.7	889.8	233.1	814.3	259.1
	5	1120.1	163.7	1060.7	185.9	993.4	209.0	920.4	233.3	843.4	259.3
	6	1155.4	163.7	1094.7	186.1	1026.1	209.2	951.5	233.6	873.0	259.6
	7	1191.3	163.8	1129.5	186.2	1059.5	209.5	983.4	233.9	903.3	259.8
	8	1227.9	163.8	1164.7	186.4	1093.6	209.7	1016.0	234.2	934.2	260.1
	9	1265.1	163.8	1200.7	186.5	1128.3	209.9	1049.2	234.4	965.8	260.3
	10	1303.2	163.8	1237.3	186.6	1163.5	210.1	1083.1	234.7	998.2	260.6
PRX EV 293.1	4	1152.9	185.4	1096.5	205.7	1034.1	227.6	968.8	250.3	901.3	272.7
	5	1188.6	186.5	1131.4	206.9	1068.8	229.1	1002.0	252.0	932.9	274.5
	6	1225.1	187.5	1166.6	208.2	1104.2	230.6	1035.8	253.6	965.1	276.3
	7	1263.4	188.5	1202.4	209.4	1138.7	232.1	1070.3	255.3	998.0	278.1
	8	1303.0	189.5	1239.0	210.6	1173.7	233.5	1105.3	256.9	1031.4	279.9
	9	1343.2	190.4	1277.7	211.9	1209.4	234.9	1139.5	258.5	1065.4	281.6
	10	1384.2	191.4	1317.3	213.1	1246.2	236.3	1174.3	260.0	1100.1	283.3
PRX EV 307.2	4	1211.2	182.0	1146.7	206.6	1073.6	232.2	994.0	259.3	910.0	288.3
	5	1249.6	182.1	1183.7	206.8	1109.2	232.5	1027.9	259.6	942.3	288.6
	6	1288.8	182.2	1221.5	207.0	1145.5	232.8	1062.7	260.0	975.4	288.9
	7	1328.8	182.3	1260.0	207.2	1182.4	233.1	1098.2	260.3	1009.1	289.2
	8	1369.4	182.3	1299.2	207.4	1220.1	233.4	1134.3	260.6	1043.6	289.5
	9	1410.6	182.3	1339.3	207.6	1258.7	233.6	1171.2	260.9	1078.8	289.8
	10	1452.6	182.3	1379.9	207.7	1298.0	233.9	1208.8	261.2	1114.8	290.1
PRX EV 345.2	4	1329.7	201.2	1258.6	228.2	1178.2	256.4	1091.0	286.3	999.1	318.3
	5	1371.8	201.3	1299.1	228.5	1217.2	256.8	1128.2	286.7	1034.4	318.6
	6	1414.6	201.5	1340.5	228.8	1256.9	257.2	1166.2	287.1	1070.6	319.0
	7	1458.3	201.6	1382.7	229.0	1297.5	257.5	1204.9	287.5	1107.5	319.3
	8	1502.9	201.7	1425.6	229.3	1338.8	257.9	1244.5	287.9	1145.2	319.7
	9	1548.1	201.7	1469.4	229.5	1380.9	258.2	1284.9	288.2	1183.6	320.1
	10	1594.1	201.8	1514.0	229.7	1423.8	258.5	1326.1	288.6	1222.9	320.4
PRX EV 365.2	4	1431.7	214.6	1355.0	243.4	1268.4	273.6	1174.5	305.5	1075.5	339.7
	5	1477.1	214.8	1398.7	243.8	1310.5	274.0	1214.6	305.9	1113.6	340.0
	6	1523.3	214.9	1443.4	244.1	1353.3	274.4	1255.6	306.3	1152.6	340.4
	7	1570.3	215.0	1489.0	244.3	1397.1	274.8	1297.4	306.7	1192.4	340.7
	8	1618.4	215.1	1535.2	244.6	1441.7	275.1	1340.0	307.1	1233.0	341.1
	9	1667.3	215.1	1582.4	244.8	1487.1	275.5	1383.6	307.5	1274.5	341.5
	10	1716.9	215.2	1630.5	245.0	1533.4	275.8	1428.1	307.9	1316.9	341.9
PRX EV 385.2	4	1514.7	227.9	1434.1	258.6	1342.9	290.6	1243.7	324.6	1139.4	360.9
	5	1562.5	228.1	1480.2	258.9	1387.1	291.1	1286.1	325.0	1179.6	361.2
	6	1610.8	228.3	1527.3	259.2	1432.3	291.5	1329.3	325.4	1220.8	361.6
	7	1660.2	228.4	1575.0	259.5	1478.5	291.9	1373.4	325.8	1262.8	362.0
	8	1710.4	228.5	1623.4	259.8	1525.5	292.2	1418.4	326.3	1305.6	362.4
	9	1761.6	228.5	1672.8	260.0	1573.2	292.6	1464.4	326.7	1349.3	362.8
	10	1813.7	228.5	1723.1	260.2	1621.5	292.9	1511.2	327.1	1394.0	363.2

Notes: C.C. (cooling capacity) and P.I. (unit power input) are referred to 0,0176m² °C/kW evaporator fouling factor and 0,0440m² °C/kW condenser fouling factor. Rated conditions are for compressors running at nominal frequency. Shaded values are referred to part load operation.

PROXIMUS “EVOLUTION” 424.2÷ 596.2 XE ST

Unit size	Leaving chilled water temp. °C	ENTERING CONDENSER WATER TEMPERATURE (ΔT=5°C)									
		20		25		30		35		40	
		Cool. Cap. (kW)	Pow. Input (kW)	Cool. Cap. (kW)	Pow. Input (kW)	Cool. Cap. (kW)	Pow. Input (kW)	Cool. Cap. (kW)	Pow. Input (kW)	Cool. Cap. (kW)	Pow. Input (kW)
PRX EV 424.2	4	1620.4	253.4	1539.9	285.3	1453.9	316.8	1362.6	349.2	1265.6	383.7
	5	1672.9	254.6	1590.7	286.8	1503.4	318.5	1410.7	351.1	1311.7	385.7
	6	1726.3	255.6	1642.7	288.1	1553.4	320.1	1459.0	352.8	1359.0	387.5
	7	1780.4	256.5	1695.7	289.3	1604.5	321.5	1508.3	354.3	1406.8	389.1
	8	1835.4	257.1	1749.1	290.2	1656.7	322.6	1558.3	355.6	1454.7	390.4
	9	1891.4	257.5	1803.5	290.9	1709.5	323.5	1609.2	356.6	1503.5	391.4
	10	1948.2	257.5	1858.8	291.2	1762.9	324.0	1661.0	357.2	1553.0	392.1
PRX EV 462.2	4	1787.7	282.9	1698.4	316.2	1603.8	350.7	1503.9	386.1	1398.7	422.5
	5	1845.0	284.3	1754.3	318.0	1657.8	352.7	1555.7	388.4	1448.2	424.8
	6	1903.6	285.5	1811.0	319.6	1712.7	354.6	1608.7	390.5	1498.5	427.0
	7	1963.2	286.6	1868.8	321.0	1768.7	356.3	1662.3	392.4	1549.9	429.1
	8	2023.5	287.4	1927.5	322.3	1825.4	357.9	1717.1	394.2	1602.3	431.0
	9	2084.7	288.1	1987.3	323.3	1883.1	359.2	1772.7	395.7	1655.4	432.6
	10	2146.7	288.5	2047.6	324.0	1941.8	360.2	1829.1	396.9	1709.5	434.0
PRX EV 508.2	4	1922.3	311.6	1827.4	346.3	1727.4	383.6	1621.5	422.1	1508.8	460.1
	5	1983.0	313.2	1886.2	348.2	1784.3	385.9	1676.1	424.6	1561.4	462.9
	6	2044.0	314.6	1946.1	350.1	1842.2	388.2	1731.8	427.2	1614.6	465.6
	7	2105.6	316.0	2007.1	352.0	1900.9	390.3	1788.6	429.6	1668.8	468.3
	8	2168.4	317.2	2067.8	353.6	1960.7	392.3	1846.1	431.9	1723.9	470.7
	9	2232.0	318.3	2129.5	355.1	2021.3	394.2	1904.4	434.0	1779.9	473.1
	10	2295.8	319.3	2192.3	356.5	2081.8	395.9	1963.7	436.0	1836.7	475.2
PRX EV 549.2	4	2085.0	340.4	1982.5	377.7	1873.9	418.3	1758.6	460.2	1637.6	501.7
	5	2149.5	342.1	2046.0	380.0	1935.0	420.9	1817.8	463.1	1694.1	504.9
	6	2215.1	343.8	2110.2	382.1	1997.3	423.4	1877.7	466.0	1751.7	507.9
	7	2281.9	345.5	2174.8	384.2	2060.7	425.9	1938.7	468.8	1810.4	511.0
	8	2349.8	347.0	2240.6	386.2	2124.5	428.3	2000.6	471.5	1869.8	513.9
	9	2418.4	348.5	2307.4	388.1	2189.0	430.6	2063.6	474.1	1930.0	516.7
	10	2487.6	349.8	2375.3	389.9	2254.5	432.8	2126.8	476.5	1991.2	519.4
PRX EV 596.2	4	2222.5	368.5	2115.1	408.4	1999.8	452.1	1877.6	497.5	1750.2	542.4
	5	2289.9	370.4	2181.7	410.9	2064.1	455.0	1940.1	500.7	1810.0	545.9
	6	2358.4	372.4	2248.8	413.4	2129.5	457.9	2003.2	503.9	1871.0	549.3
	7	2428.1	374.3	2316.3	415.8	2196.2	460.7	2067.2	507.1	1933.0	552.8
	8	2499.2	376.2	2384.9	418.1	2262.8	463.5	2132.3	510.2	1995.6	556.2
	9	2571.4	378.1	2454.7	420.5	2330.1	466.3	2198.5	513.3	2059.0	559.5
	10	2643.9	379.9	2525.7	422.8	2398.5	469.0	2264.7	516.3	2123.3	562.8

Notes: C.C. (cooling capacity) and P.I. (unit power input) are referred to 0,0176m² °C/kW evaporator fouling factor and 0,0440m² °C/kW condenser fouling factor. Rated conditions are for compressors running at nominal frequency. Shaded values are referred to part load operation.

EVAPORATOR PRESSURE DROPS

Proximus "Evolution" SE ST

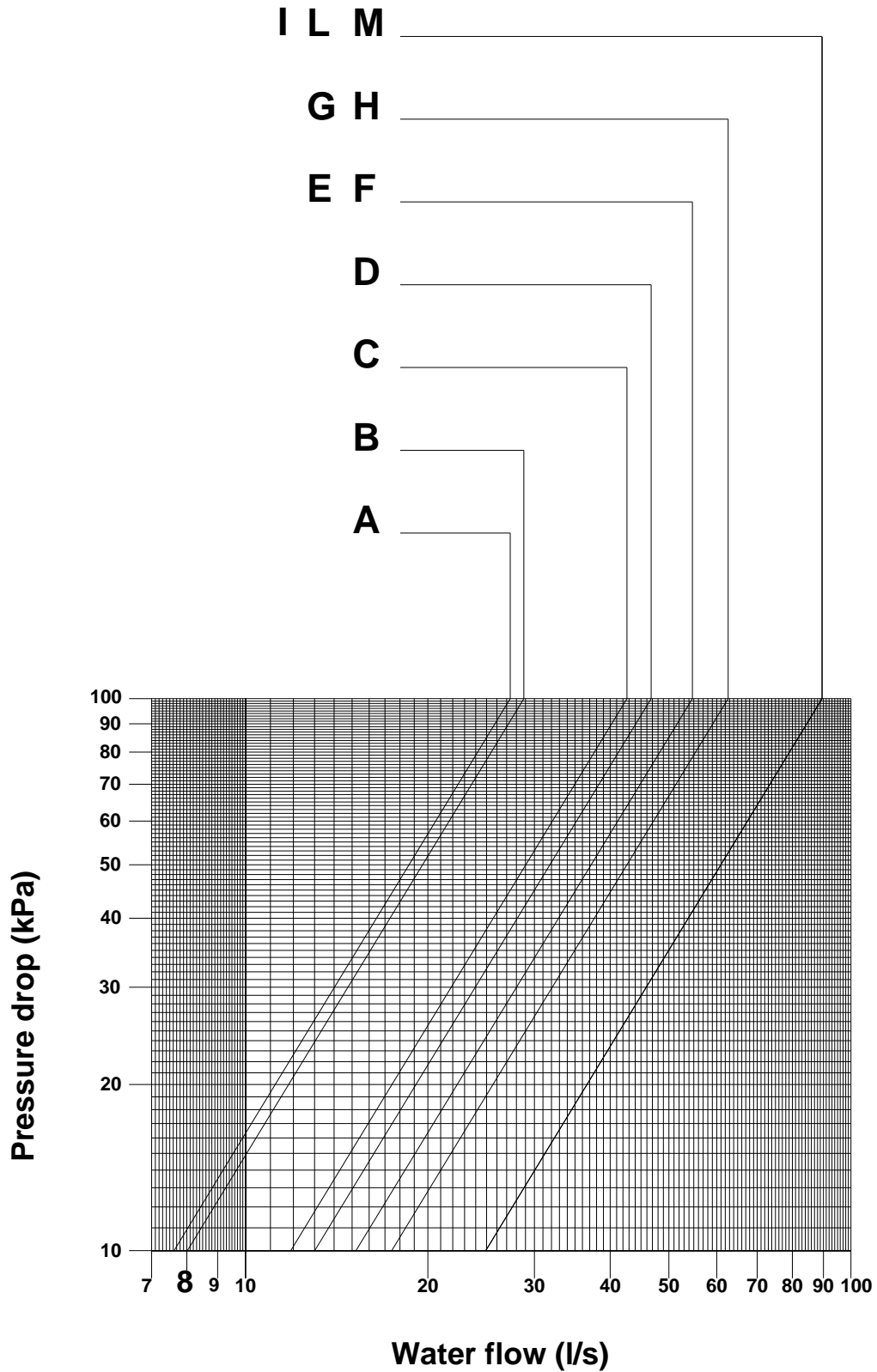

A.	111.1	G.	279.2
B.	135.1	H.	307.2
C.	164.1	I.	345.2
D.	186.1	L.	365.2
E.	231.2	M.	385.2
F.	254.2		

Proximus "Evolution" SE ST

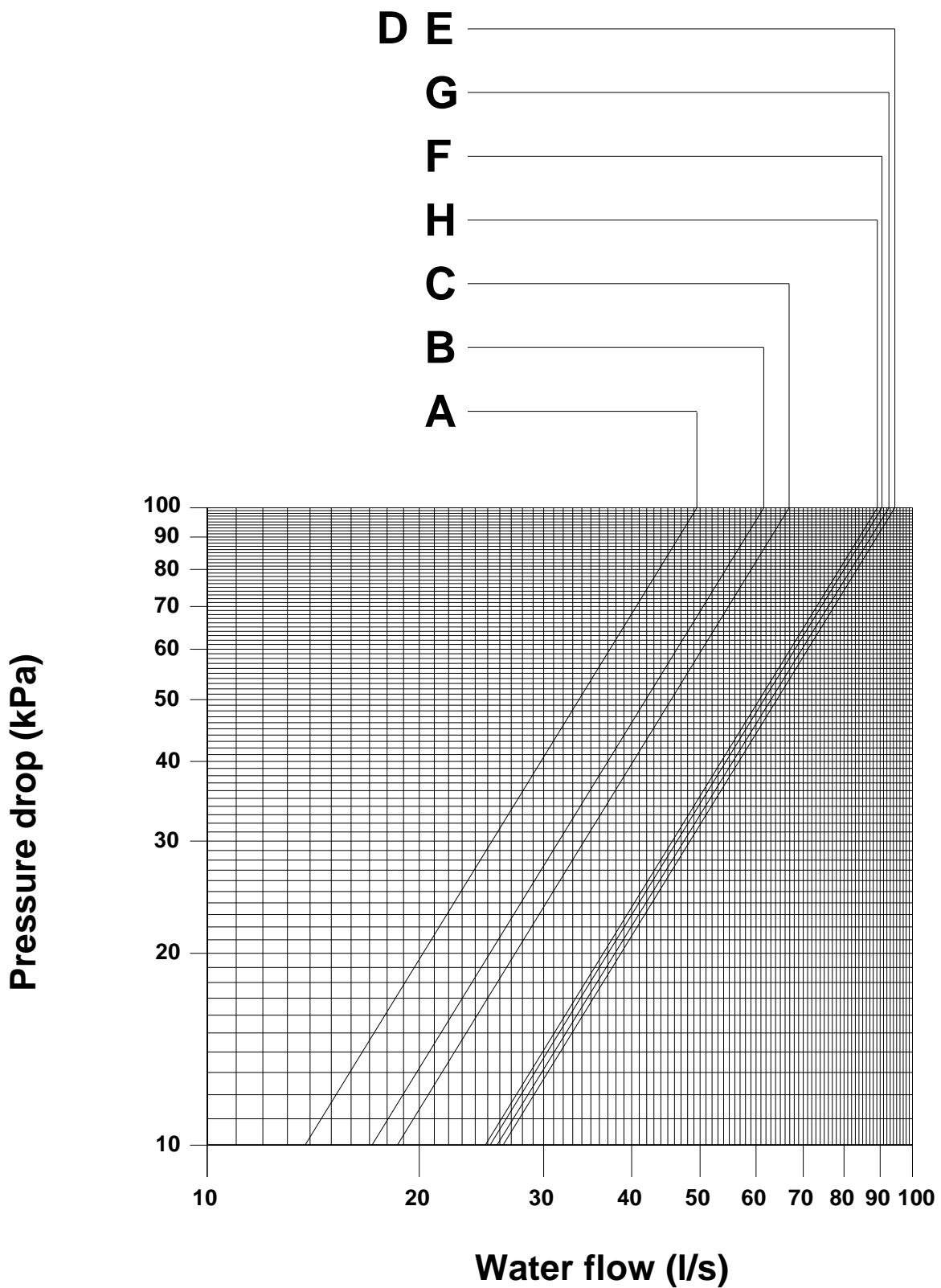

A. 211.1	E. 462.2
B. 251.1	F. 508.2
C. 293.1	G. 549.2
D. 424.2	H. 596.2

Proximus "Evolution" XE ST

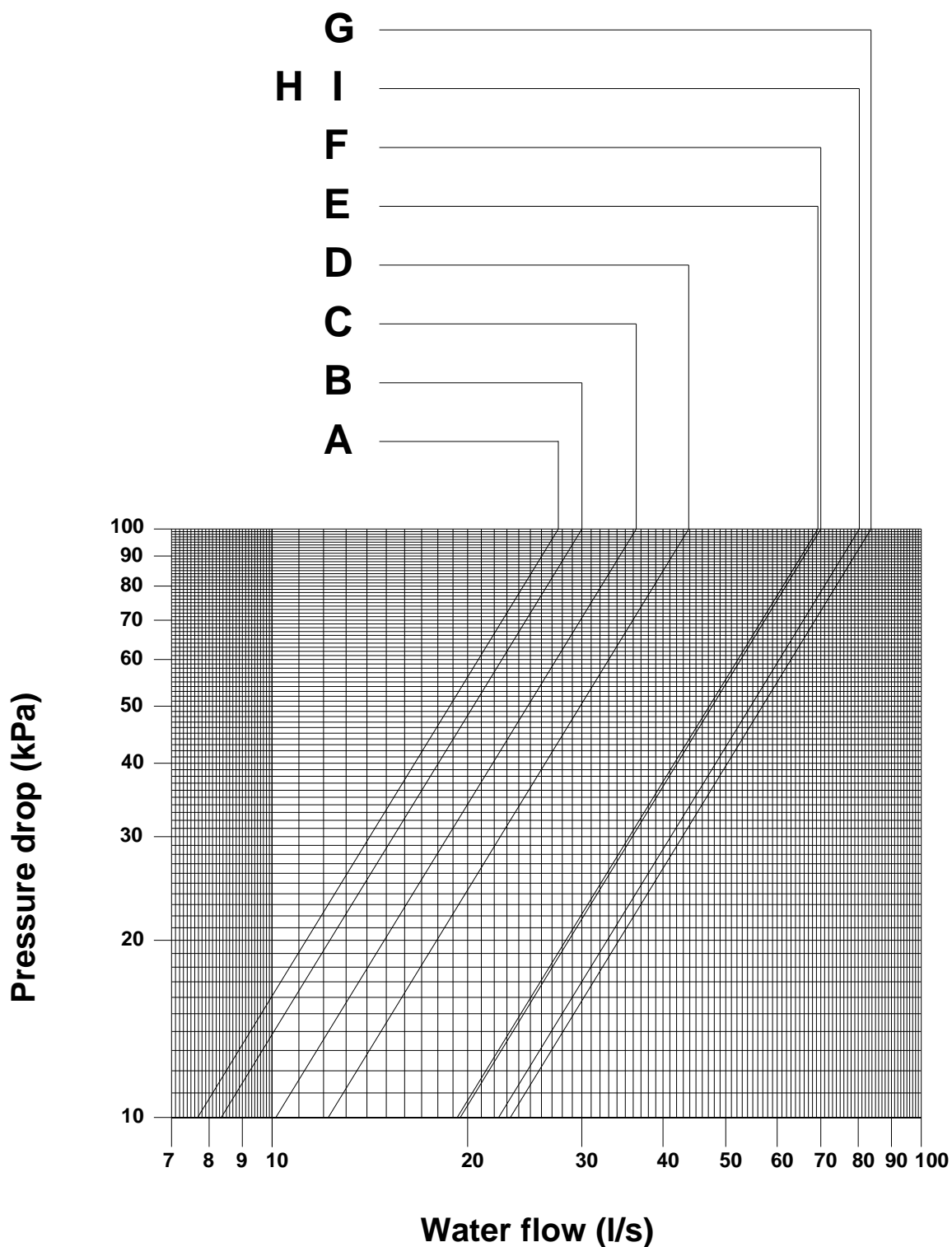

A.	111.1	F.	307.2
B.	135.1	G.	345.2
C.	164.1	H.	365.2
D.	186.1	I.	385.2
E.	279.2		

Proximus "Evolution" XE ST

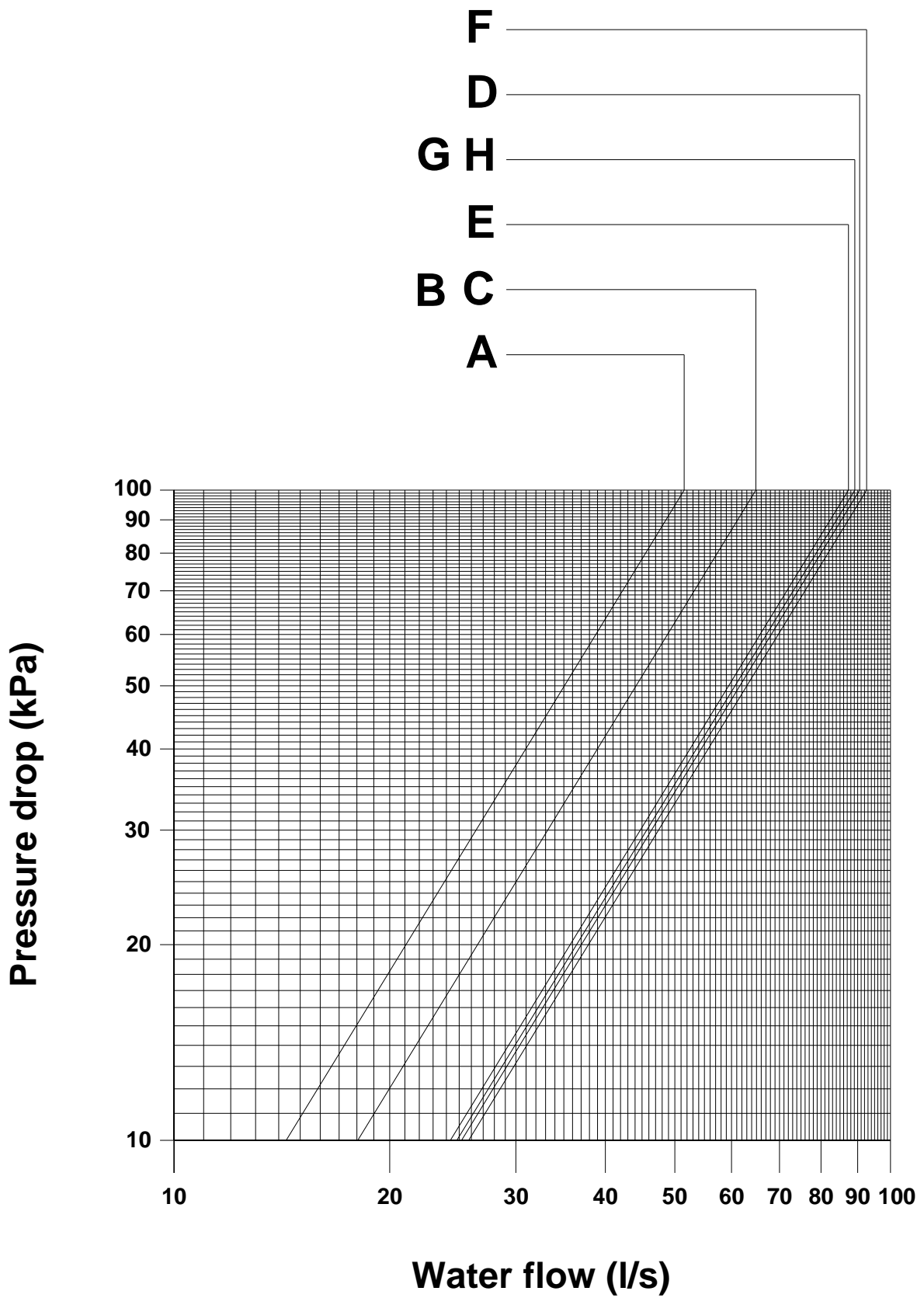

A.	211.1	E.	462.2
B.	251.1	F.	508.2
C.	293.1	G.	549.2
D.	424.2	H.	596.2

CONDENSER PRESSURE DROPS

Proximus "Evolution" SE ST

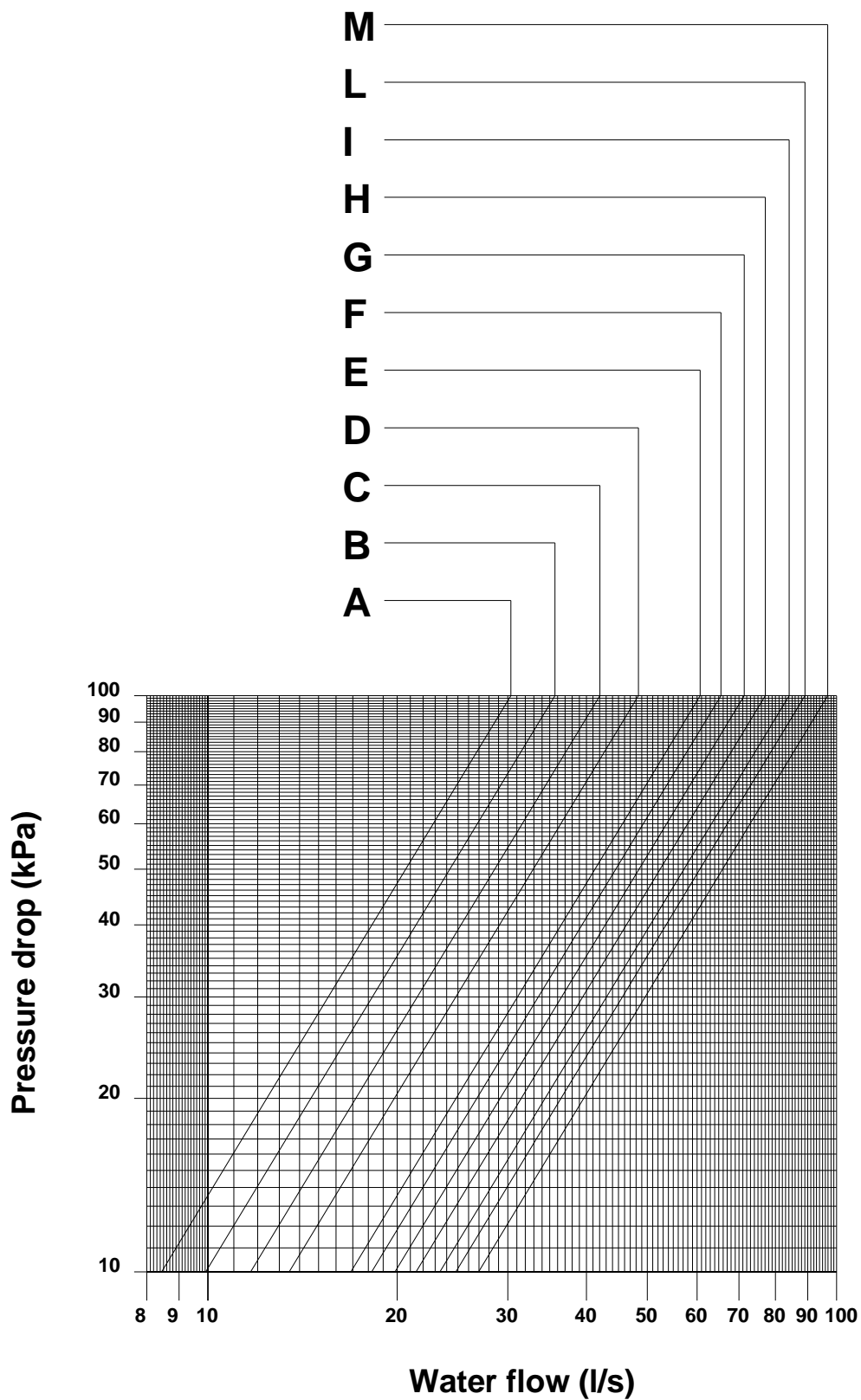

A.	111.1	G.	279.2
B.	135.1	H.	307.2
C.	164.1	I.	345.2
D.	186.1	L.	365.2
E.	231.2	M.	385.2
F.	254.2		

Proximus "Evolution" SE ST

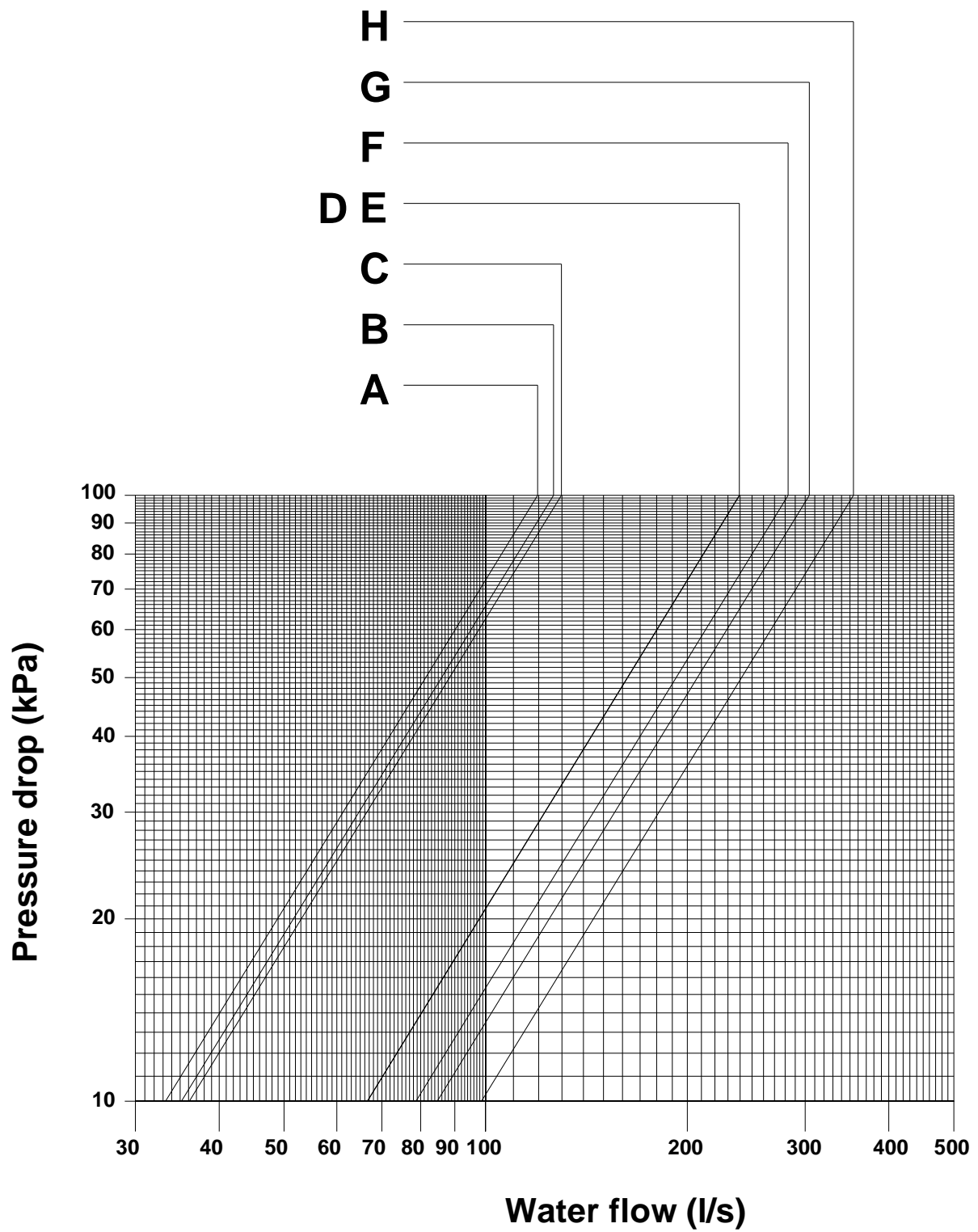

A.	211.1	E.	462.2
B.	251.1	F.	508.2
C.	293.1	G.	549.2
D.	424.2	H.	596.2

Proximus "Evolution" XE ST

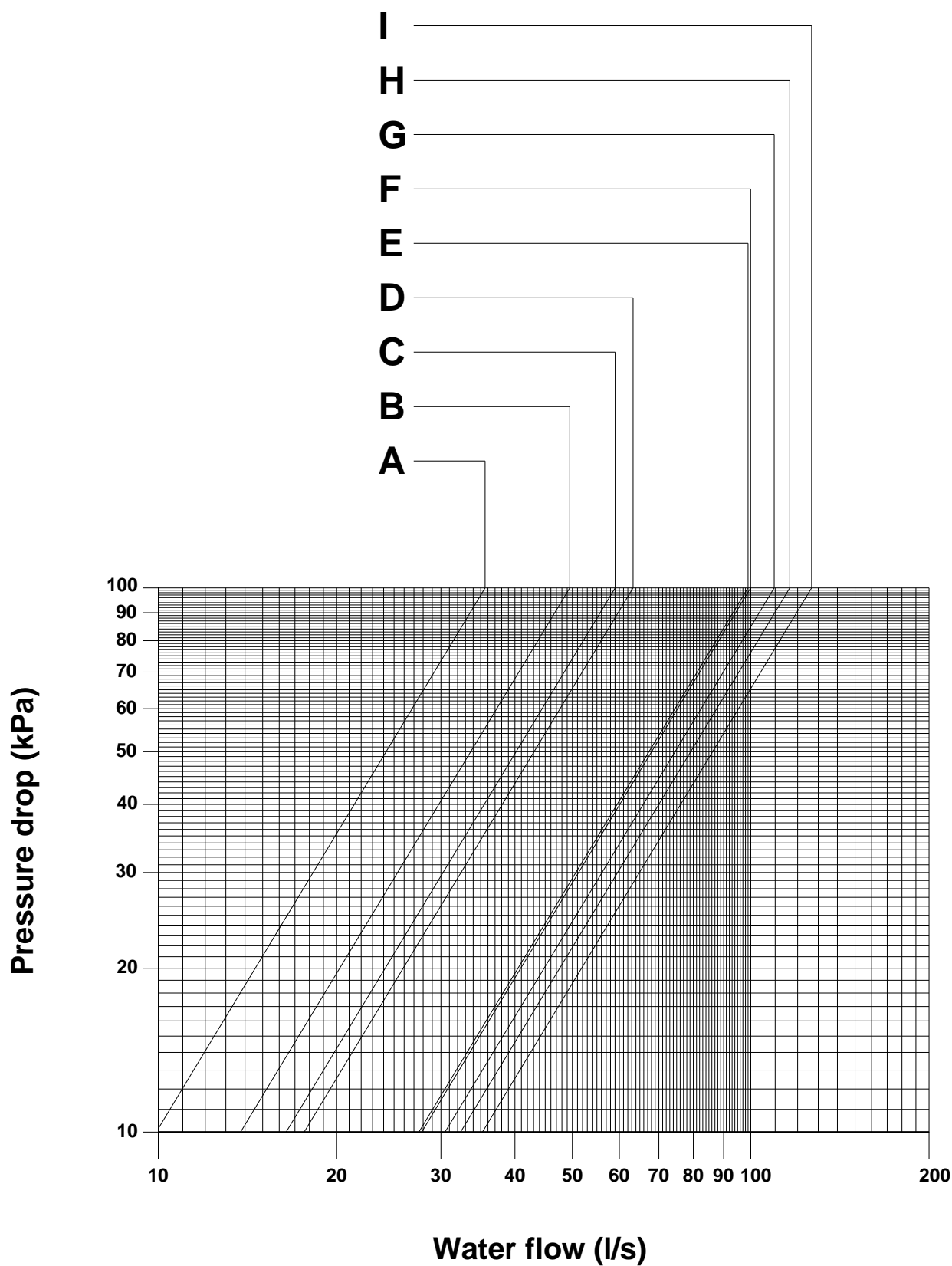

Proximus "Evolution" XE ST

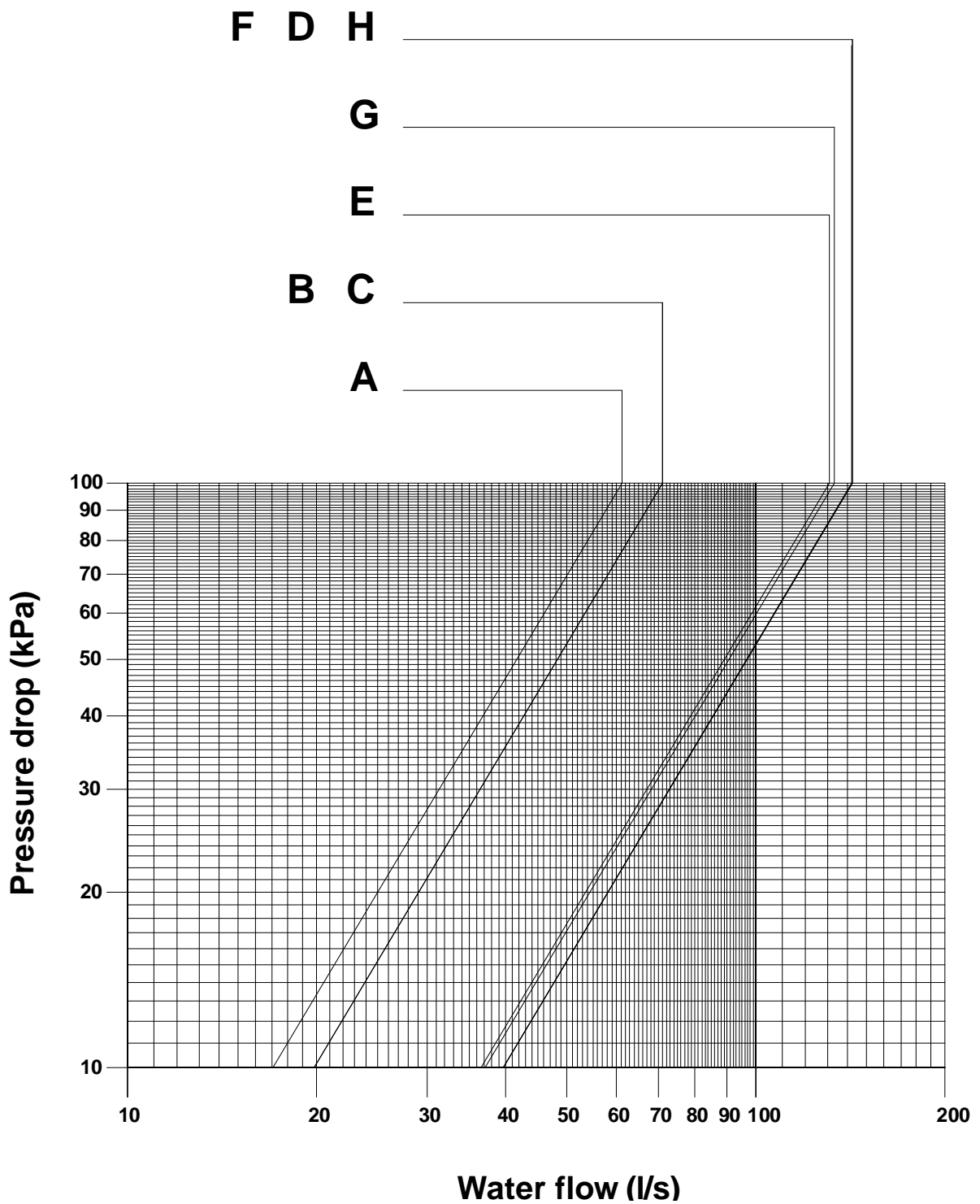

A.	211.1	E.	462.2
B.	251.1	F.	508.2
C.	293.1	G.	549.2
D.	424.2	H.	596.2

OPTIONAL

Partial heat recovery ratings – Proximus “Evolution” SE ST

Unit size		HEAT RECOVERY LEAVING WATER TEMPERATURE ($\Delta T=5^{\circ}\text{C}$)		
		45	50	55
		Heating capacity (kW)	Heating capacity (kW)	Heating capacity (kW)
111.1	Evaporator leaving water temp. $7^{\circ}\text{C} - \Delta T 5^{\circ}\text{C}$ Condenser leaving water temperature 35°C	54.2	38.5	23.6
135.1		66.2	48.0	30.6
164.1		83.0	60.3	38.5
186.1		88.9	64.6	41.1
211.1		119.3	89.7	61.4
231.2		114.3	81.4	49.9
251.1		145.5	112.5	79.9
254.2		129.3	93.9	60.2
279.2		137.2	99.3	63.0
293.1		174.5	136.9	100.7
307.2		157.4	114.8	74.1
345.2		172.3	122.0	74.1
365.2		185.3	134.7	86.6
385.2		194.0	137.5	83.7
424.2		254.4	191.1	131.3
462.2		282.0	214.1	149.7
508.2		301.0	226.6	155.9
549.2		318.7	240.6	166.4
596.2		344.4	257.9	175.7

Partial heat recovery ratings – Proximus “Evolution” XE ST

Unit size	Evaporator leaving water temp. 7°C - ΔT 5°C Condenser leaving water temperature 35°C	HEAT RECOVERY LEAVING WATER TEMPERATURE (ΔT=5°C)		
		45	50	55
		Heating capacity (kW)	Heating capacity (kW)	Heating capacity (kW)
111.1		54.4	37.5	21.3
135.1		65.5	45.9	27.1
164.1		77.4	52.4	28.5
186.1		93.6	65.3	38.3
211.1		106.3	76.0	47.1
251.1		125.3	86.0	48.5
279.2		131.5	89.7	50.0
293.1		152.4	109.8	69.1
307.2		148.8	103.5	60.4
345.2		163.3	111.9	63.0
365.2		175.4	122.2	71.5
385.2		182.5	123.6	67.5
424.2		203.2	139.9	79.6
462.2		228.4	161.7	98.1
508.2		253.3	177.7	105.7
549.2		276.1	199.1	125.6
596.2		301.7	216.9	135.9

Partial heat recovery pressure drops – Proximus “Evolution” SE ST

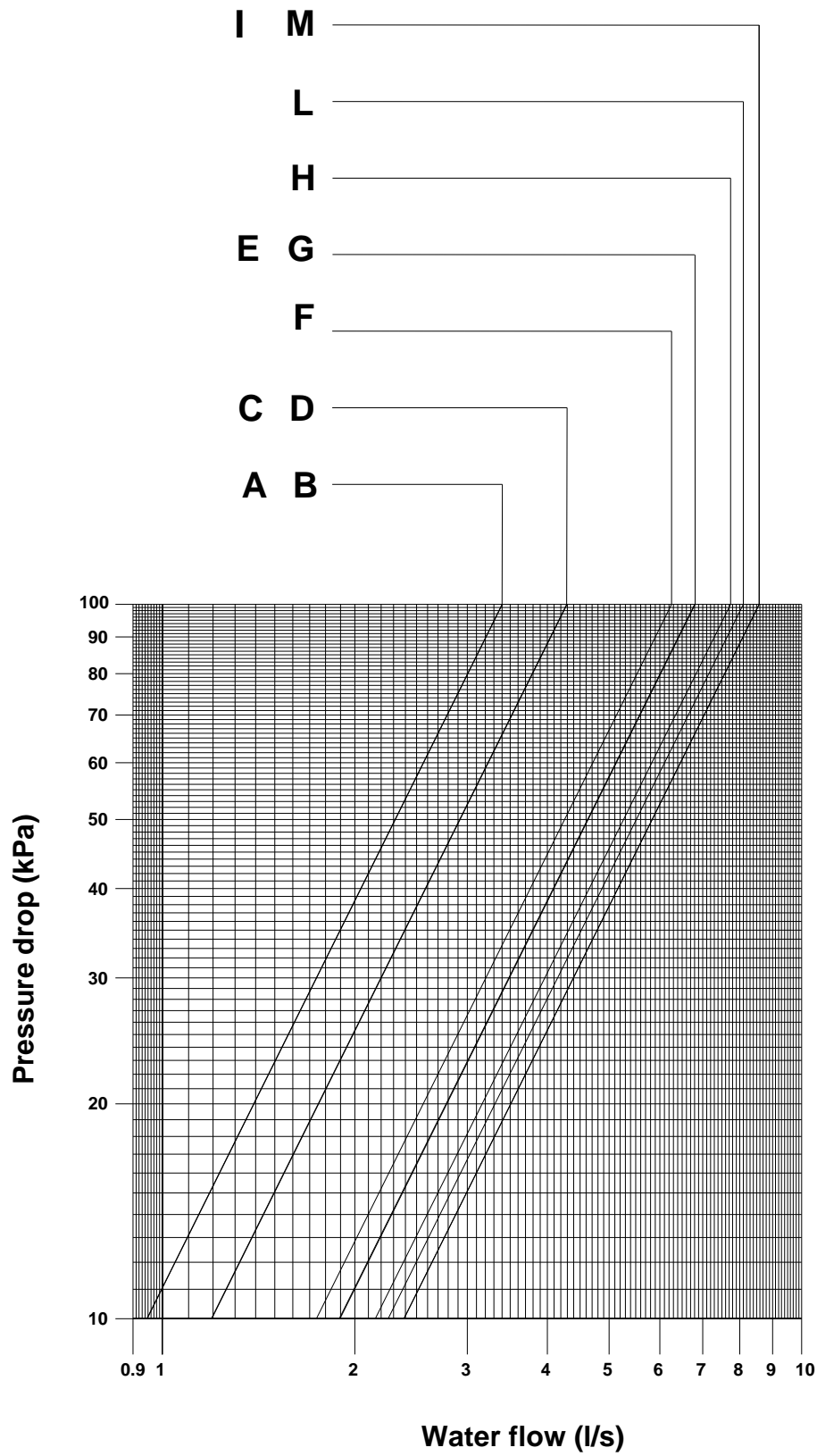

A.	111.1	G.	279.2
B.	135.1	H.	307.2
C.	164.1	I.	345.2
D.	186.1	L.	365.2
E.	231.2	M.	385.2
F.	254.2		

Partial heat recovery pressure drops – Proximus “Evolution” SE ST

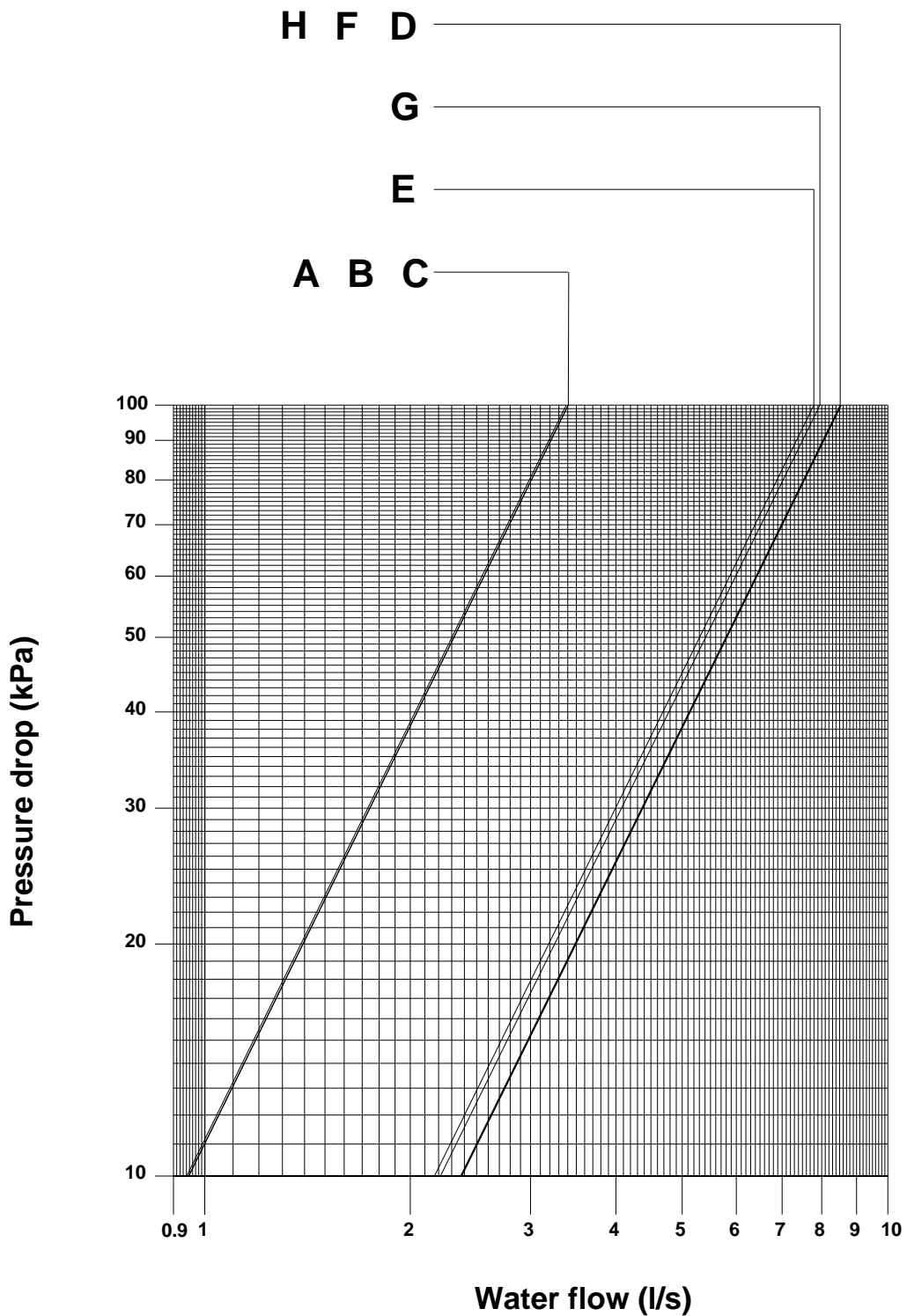

A. 211.1	E. 462.2
B. 251.1	F. 508.2
C. 293.1	G. 549.2
D. 424.2	H. 596.2

Partial heat recovery pressure drops – Proximus “Evolution” XE ST

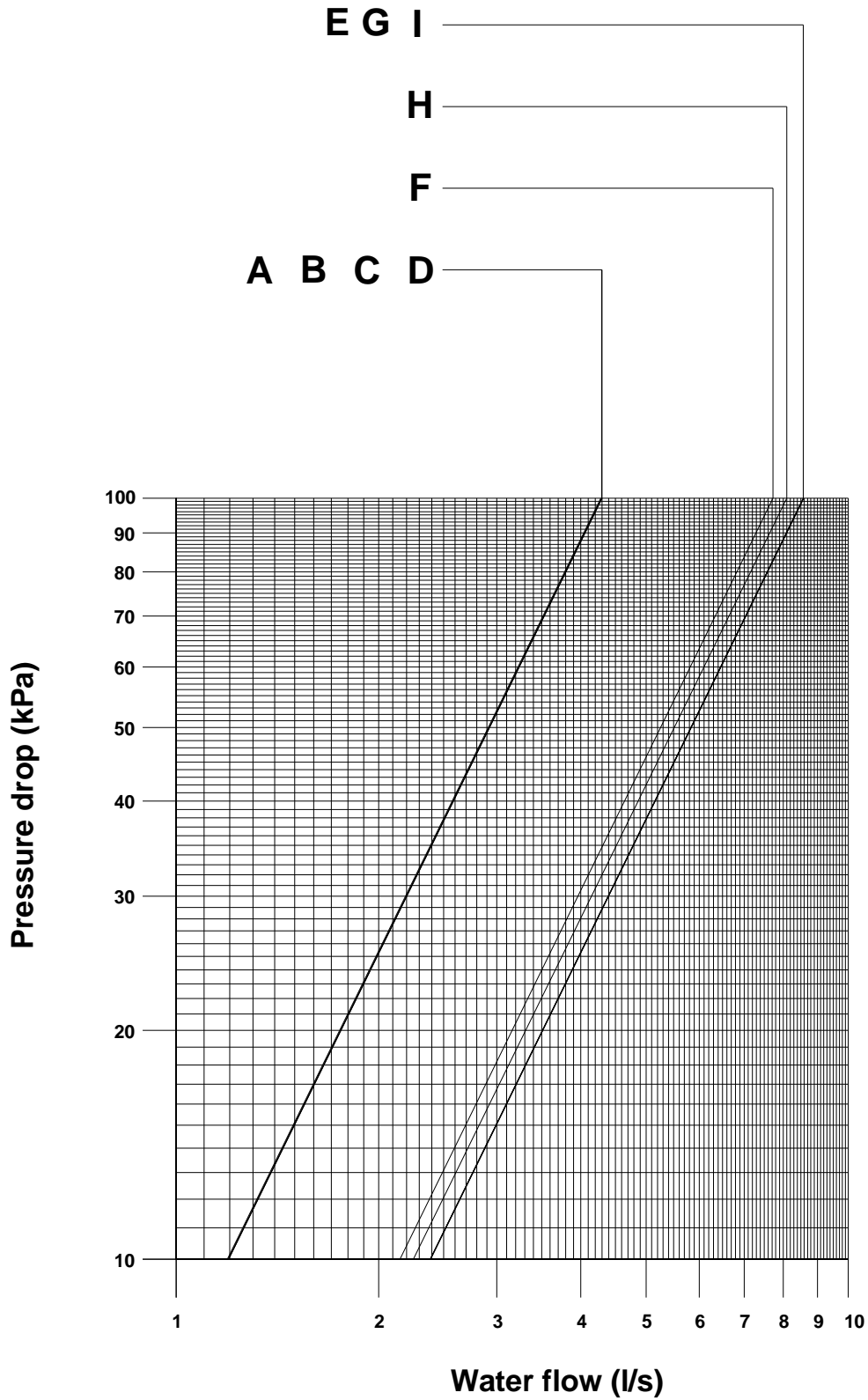

Partial heat recovery pressure drops – Proximus “Evolution” XE ST

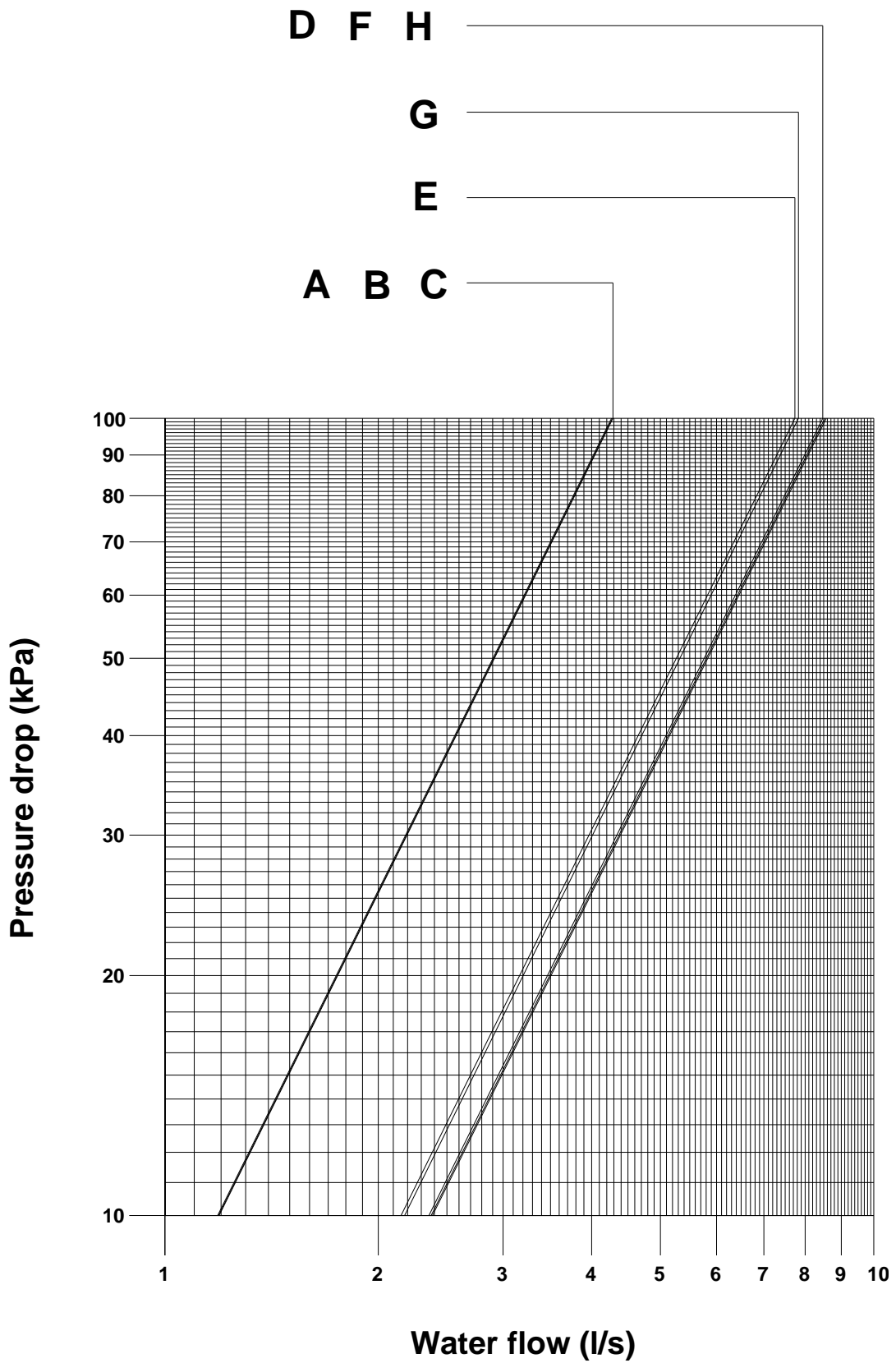

A. 211.1	E. 462.2
B. 251.1	F. 508.2
C. 293.1	G. 549.2
D. 424.2	H. 596.2

DIMENSIONS

Proximus "Evolution" 111.1 ÷ 135.1 SE ST

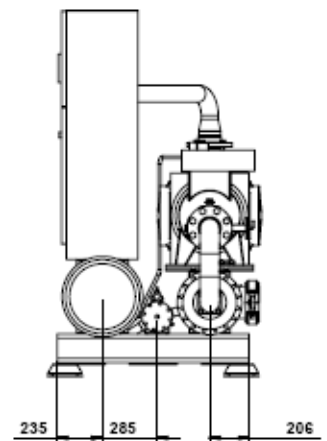
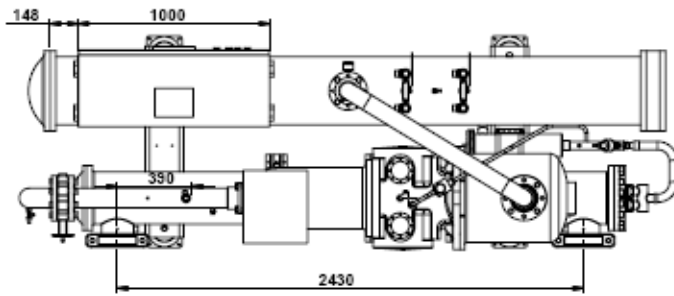
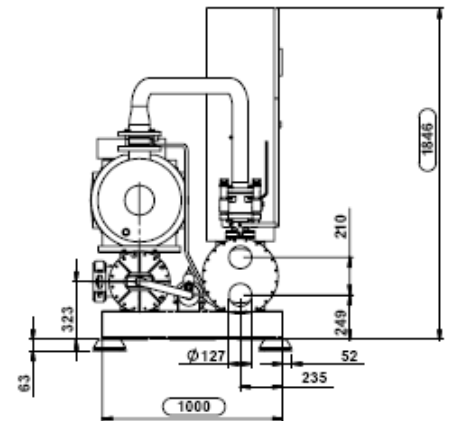
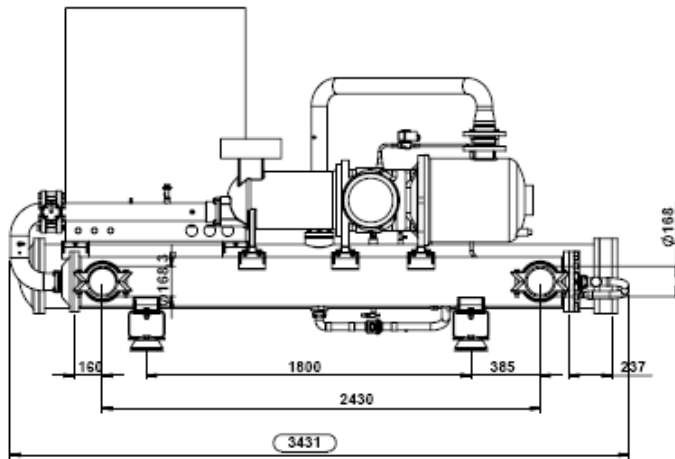

Proximus "Evolution" 164.1 ÷ 186.1 SE ST

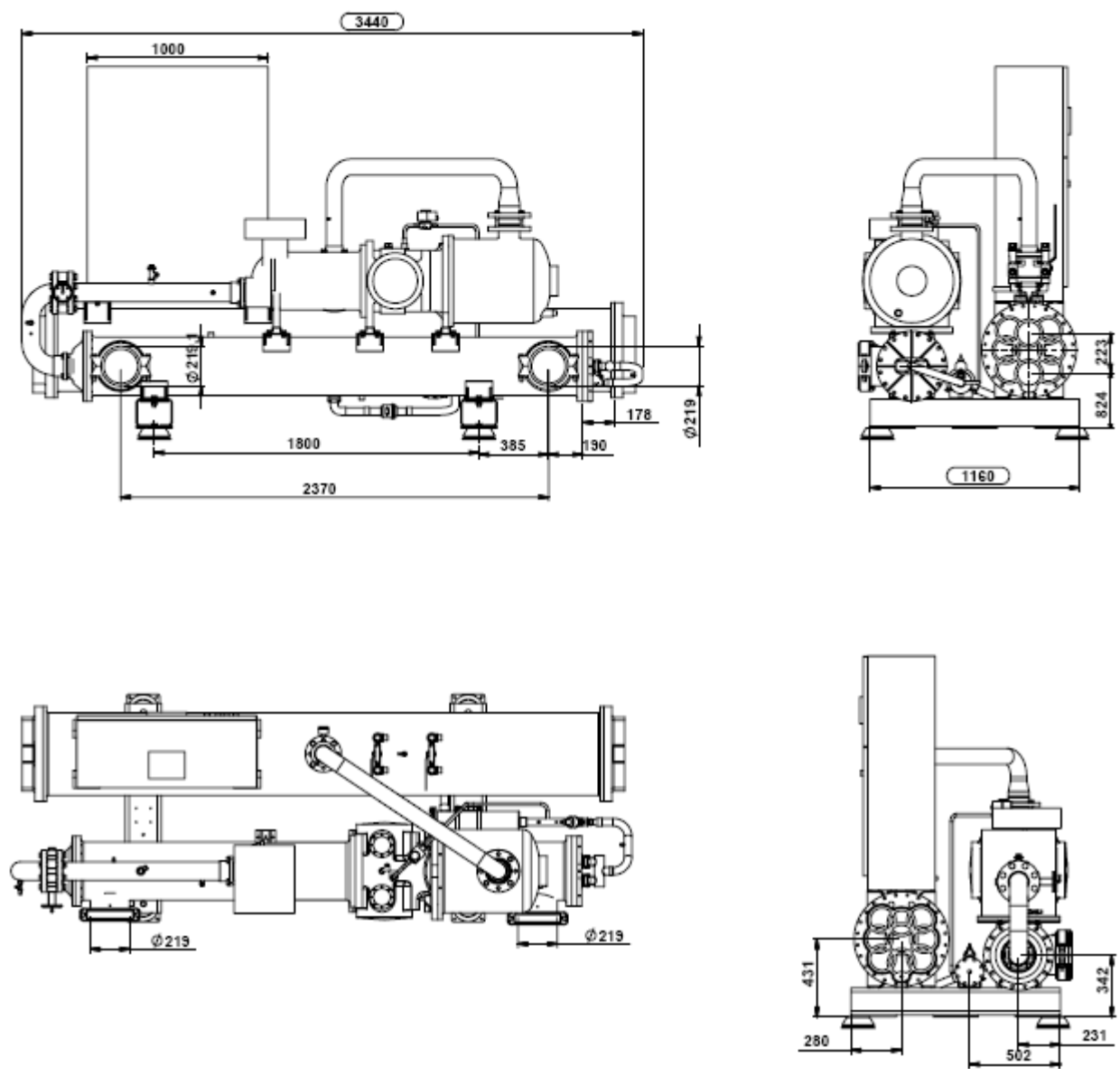

Proximus "Evolution" 211.1 – 251.1 – 293.1 SE ST

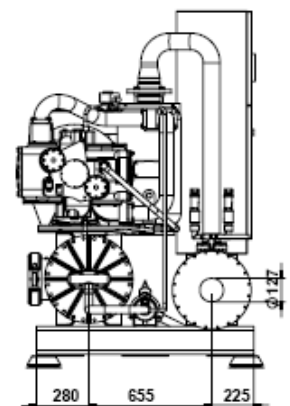
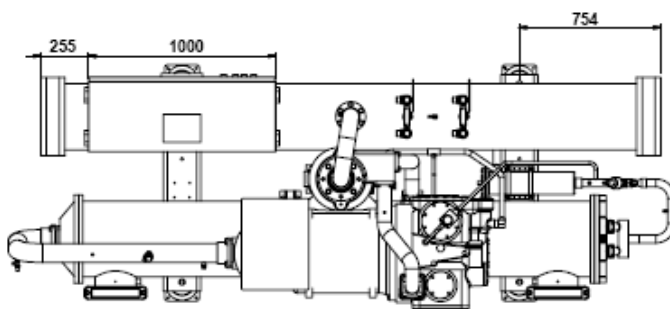
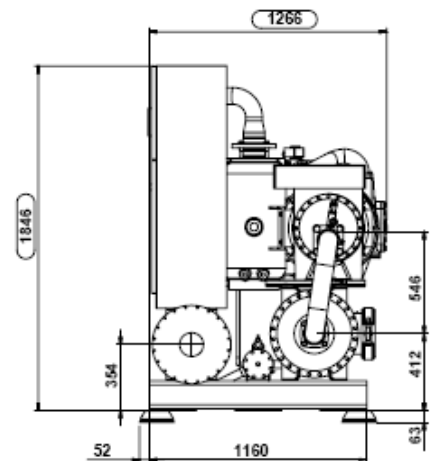
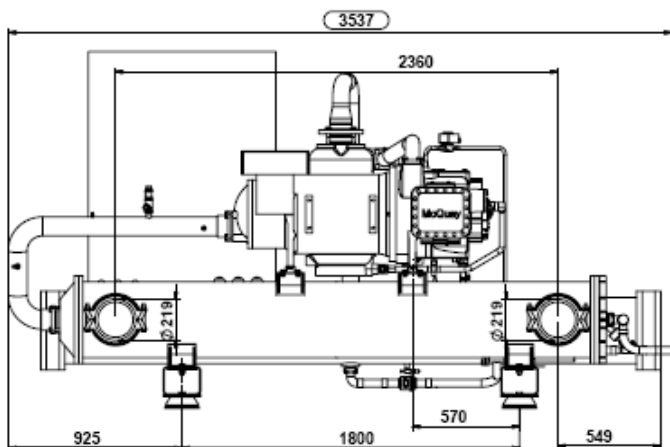

Proximus "Evolution" 231.2 – 254.2 – 279.2 SE ST

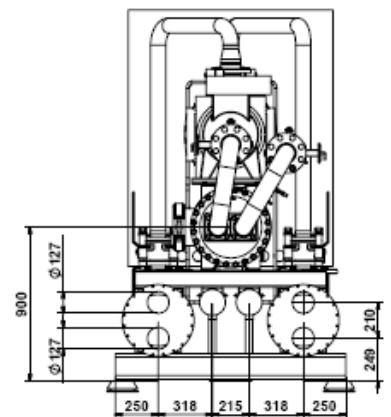
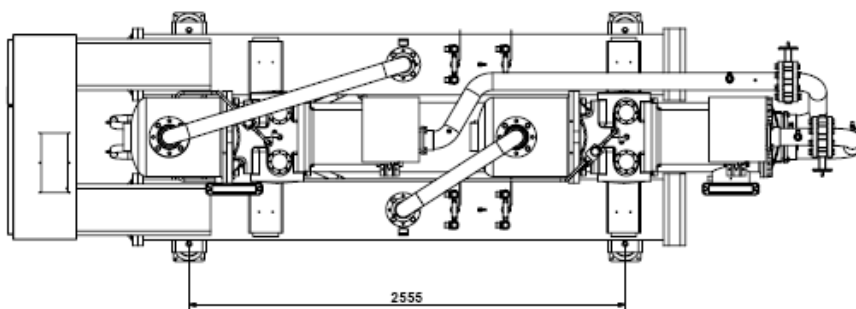
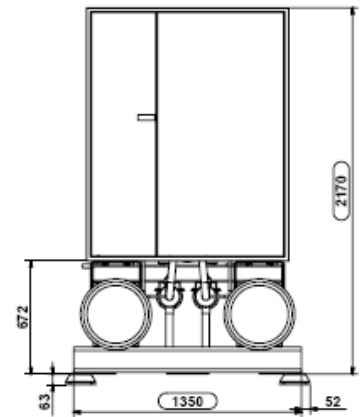
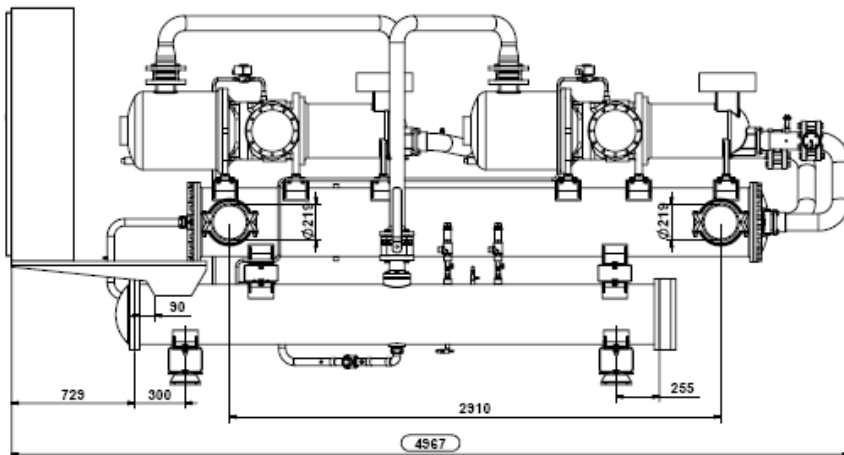

Proximus "Evolution" 307.2 SE ST

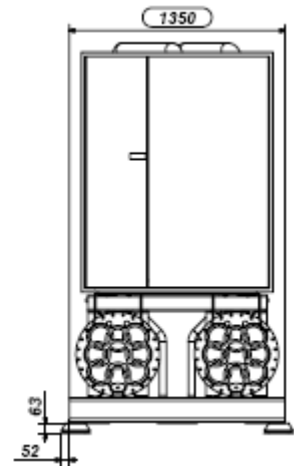
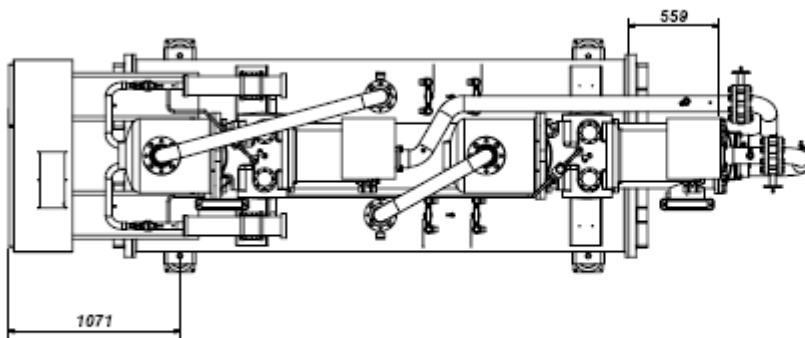
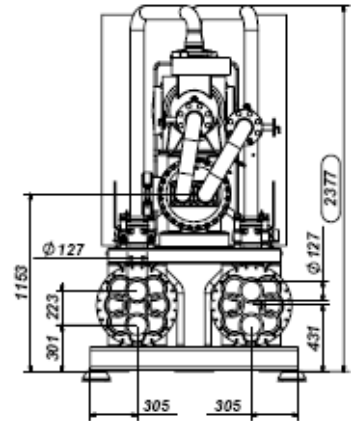
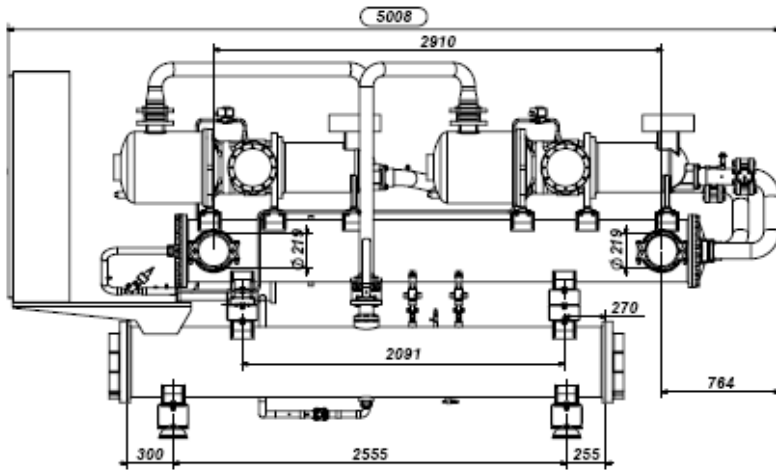

Proximus "Evolution" 345.2 ÷ 385.2 SE ST

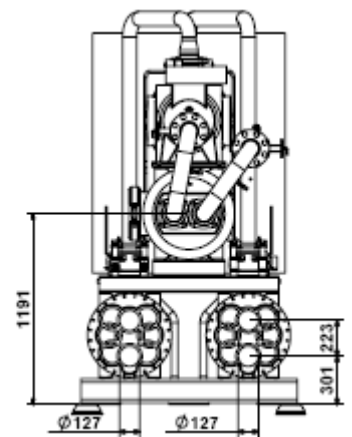
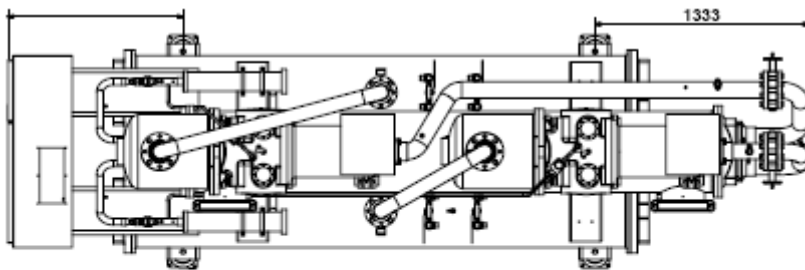
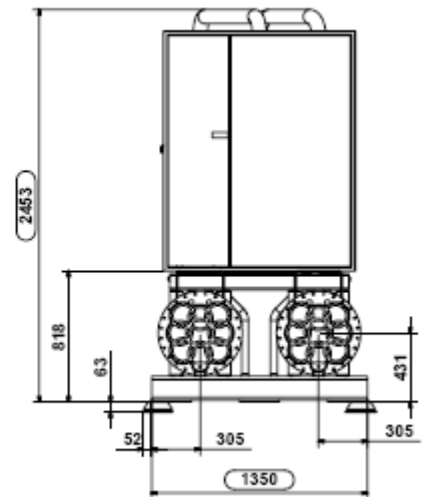
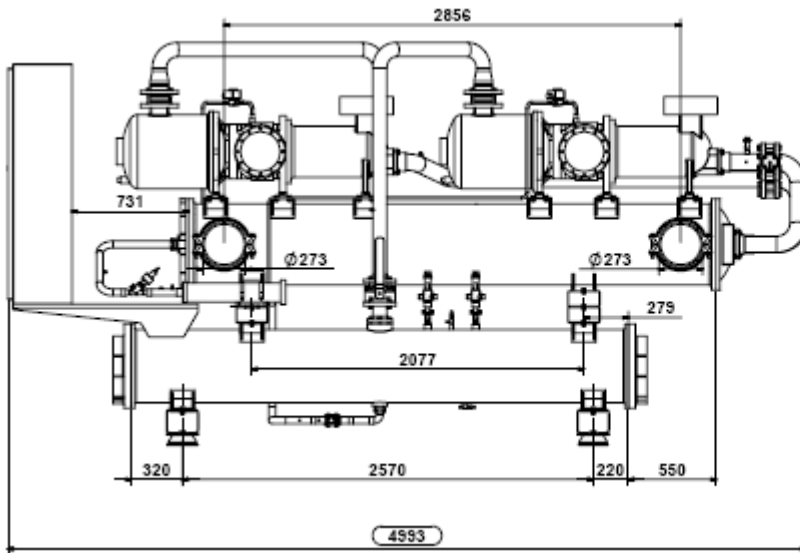

Proximus "Evolution" 424.2 ÷ 508.2 SE ST

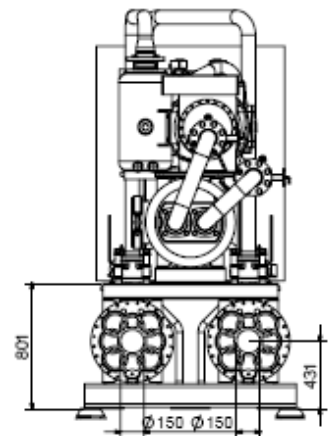
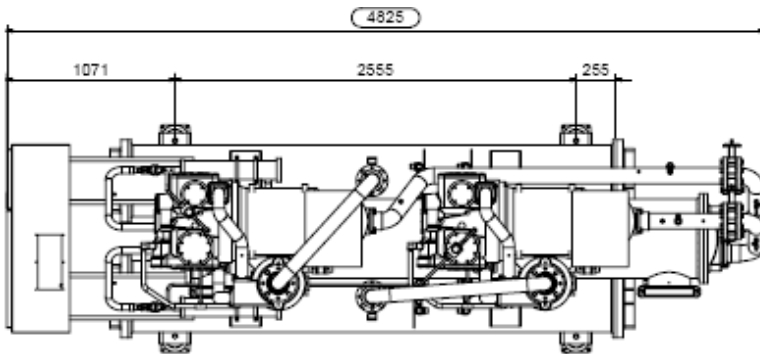
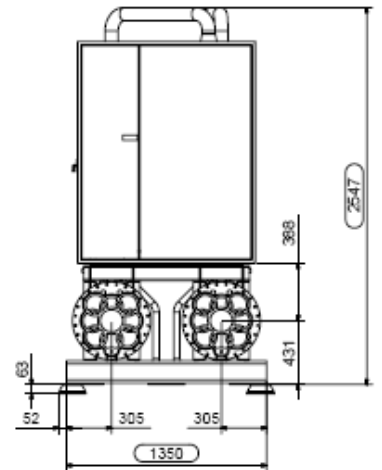
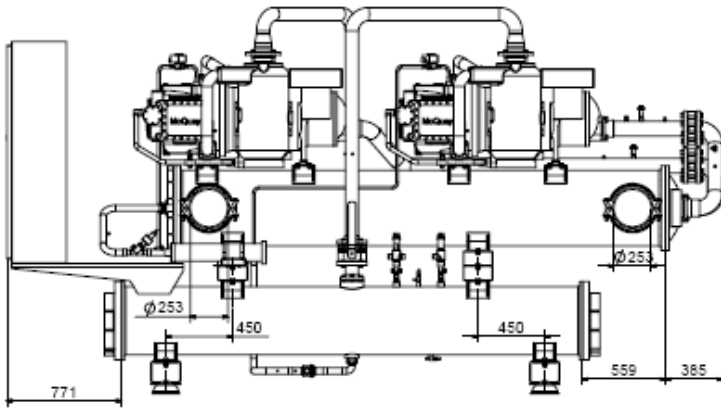

Proximus "Evolution" 549.2 ÷ 596.2 SE ST

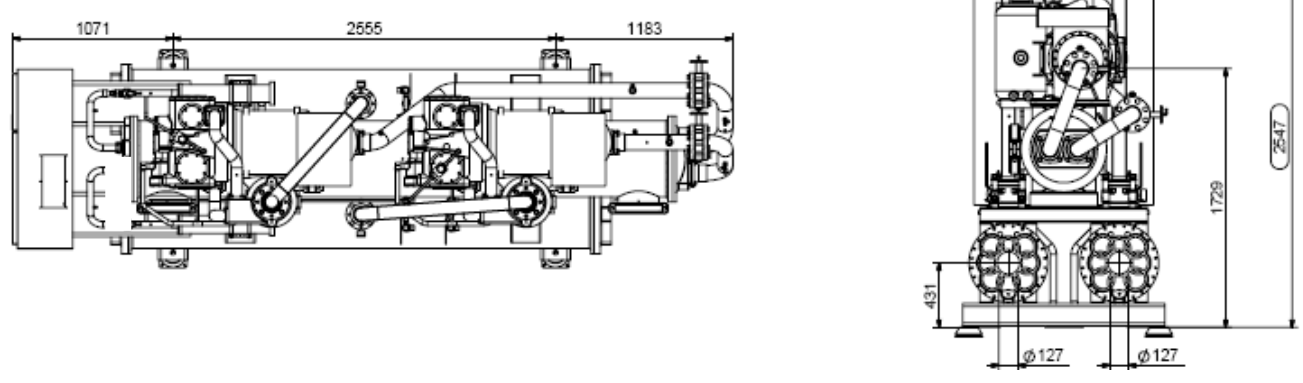
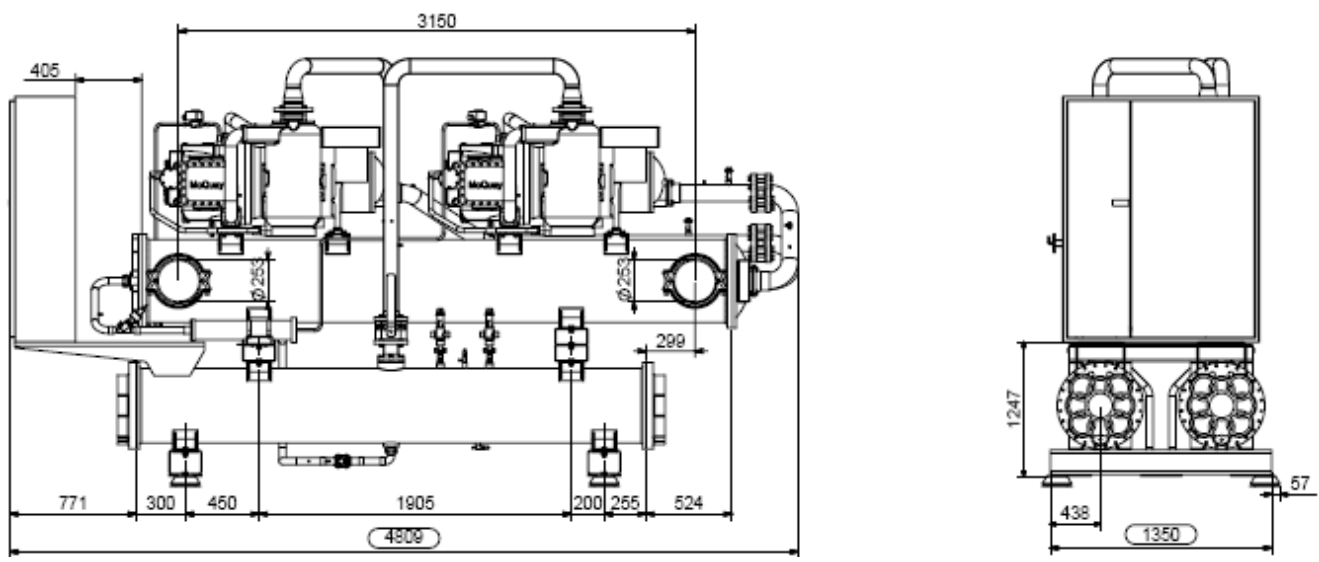

Proximus "Evolution" 111.1 ÷ 164.1 XE ST

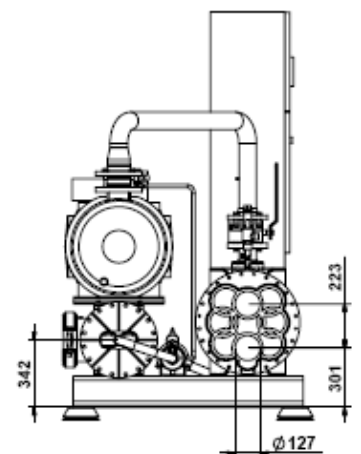
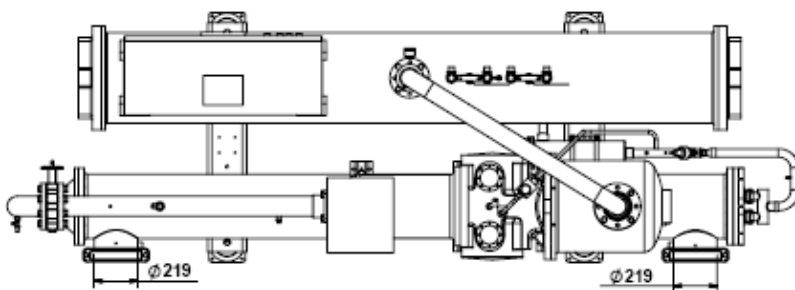
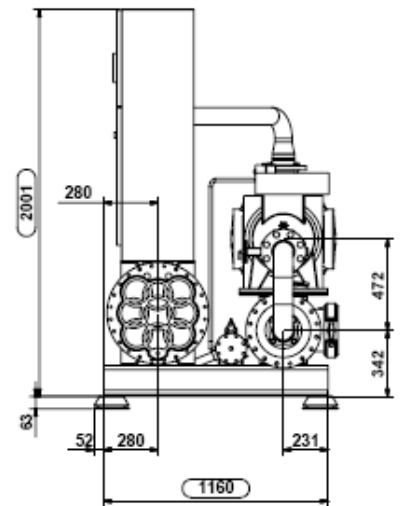
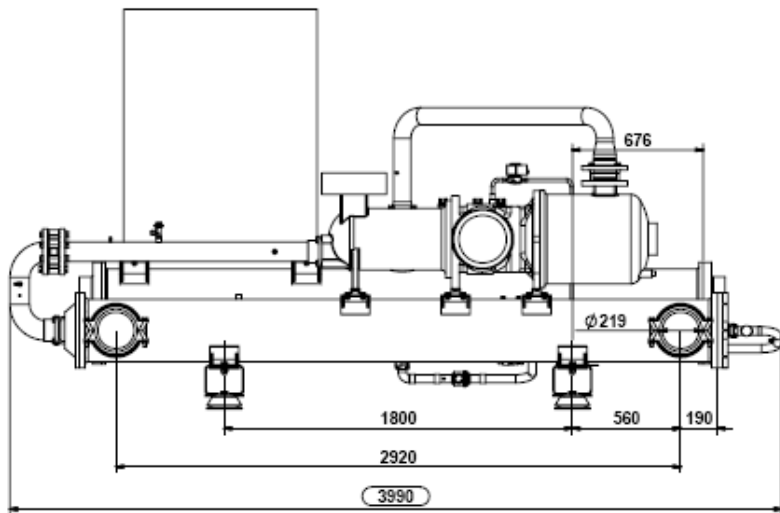

Proximus "Evolution" 186.1 XE ST

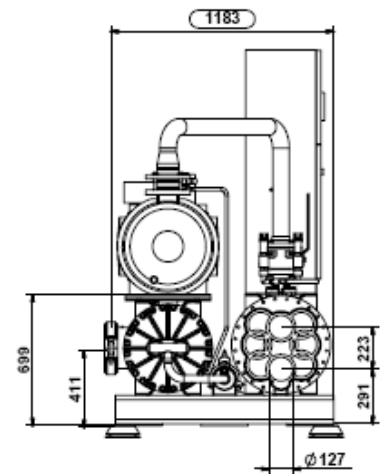
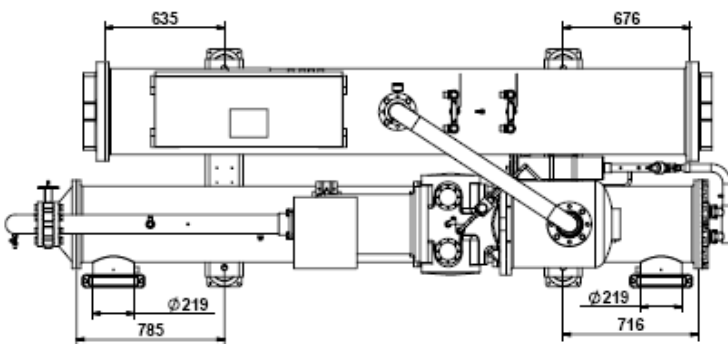
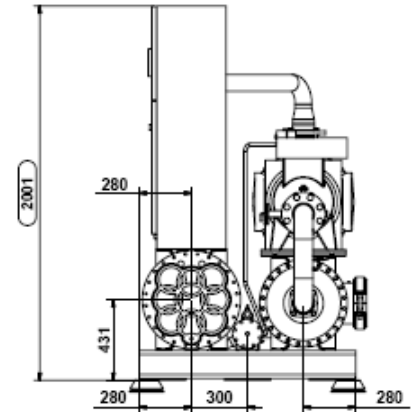
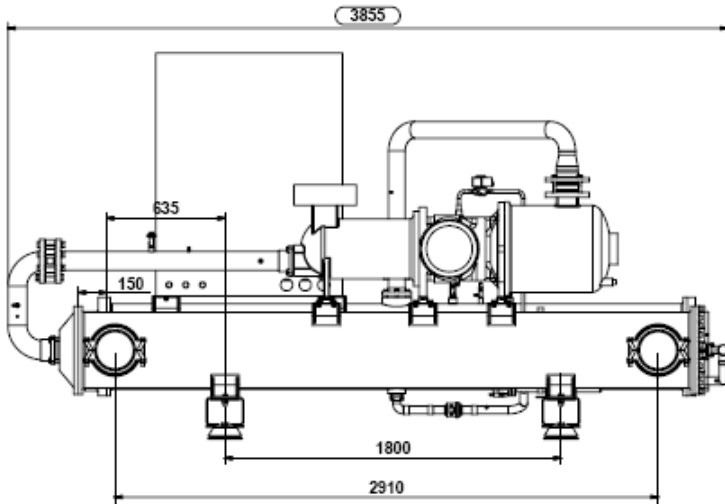

Proximus "Evolution" 211.1 XE ST

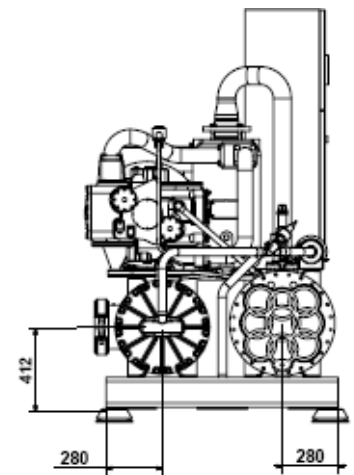
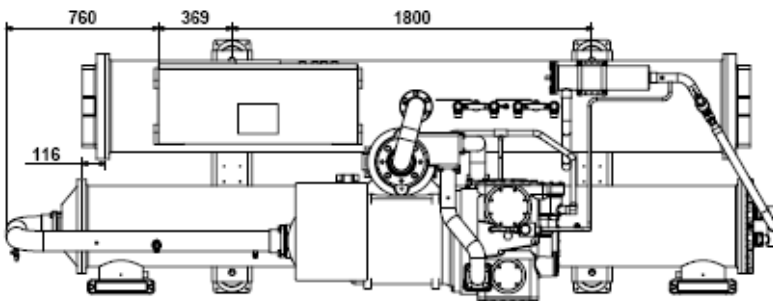
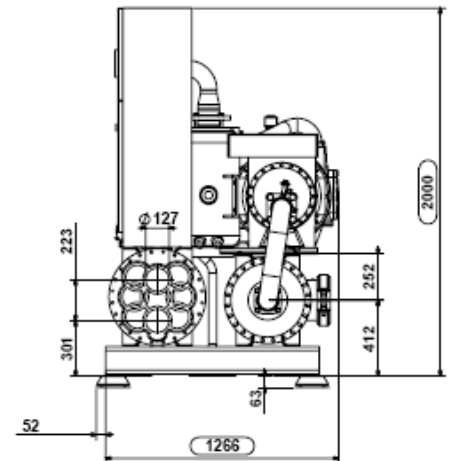
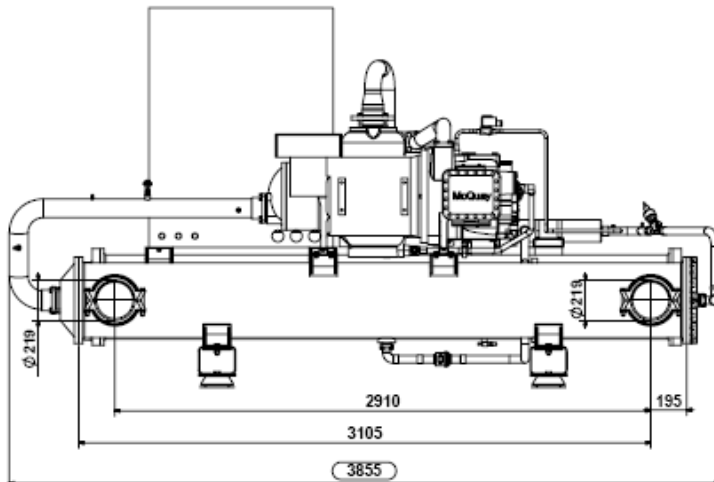

Proximus "Evolution" 279.2 - 307.2 - 345.2 - 365.2 - 385.2 XE ST

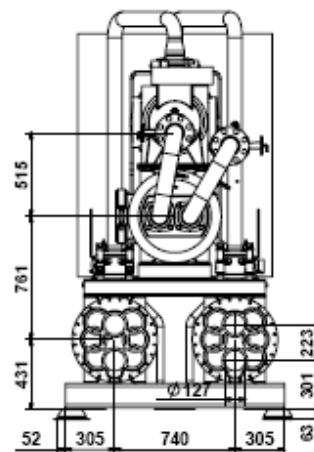
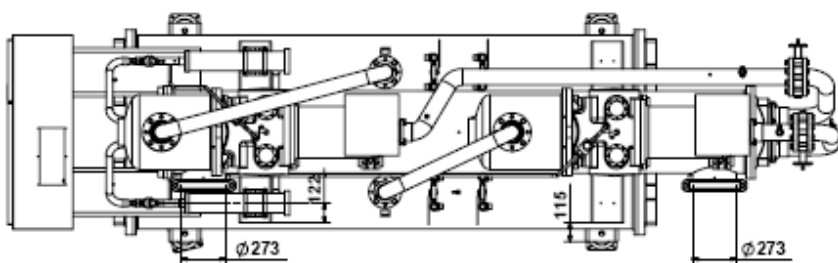
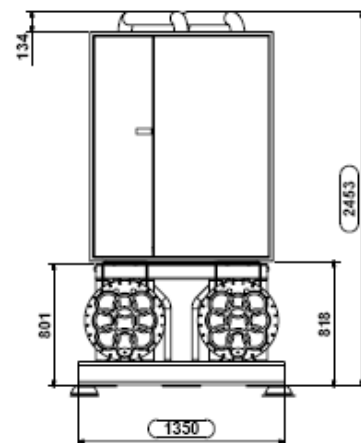
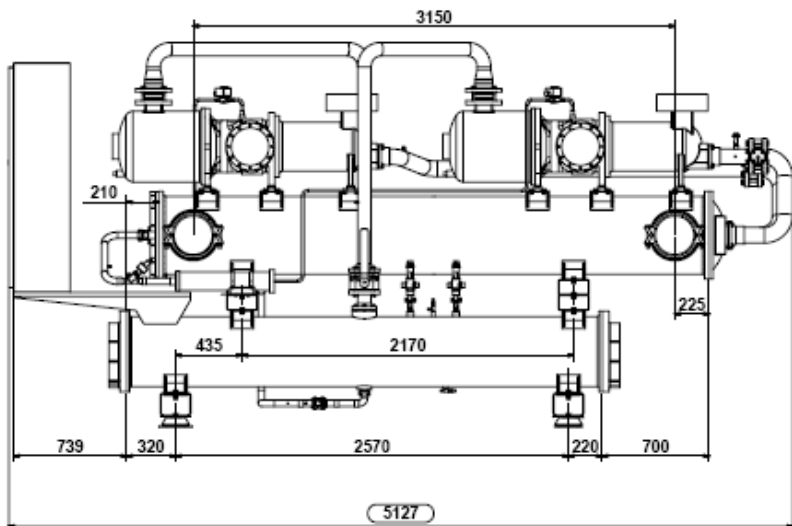

Proximus "Evolution" 251.1 – 293.1 XE ST

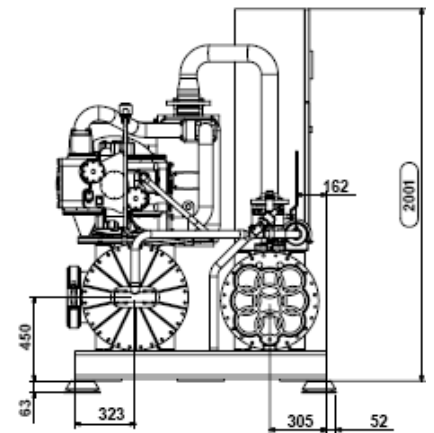
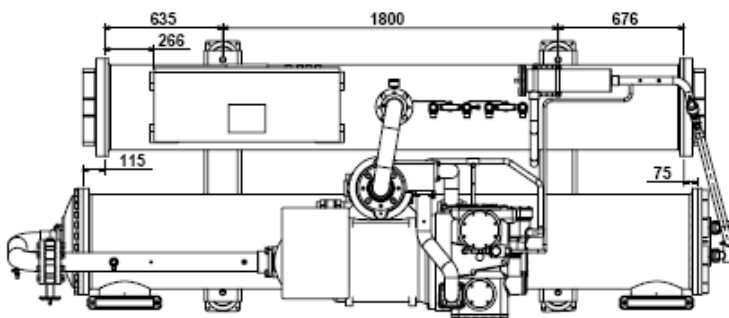
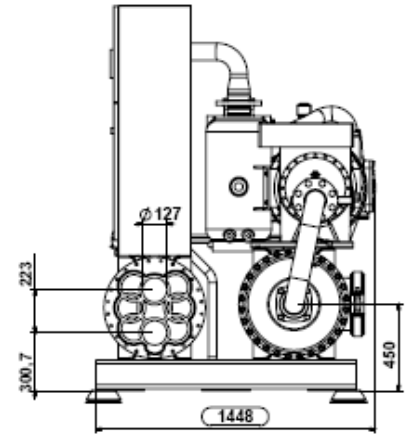
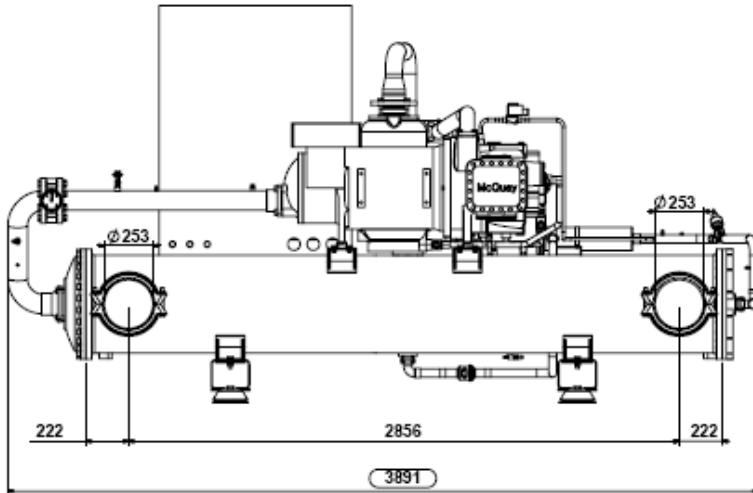

Proximus "Evolution" 424.2 ÷ 462.2 XE ST

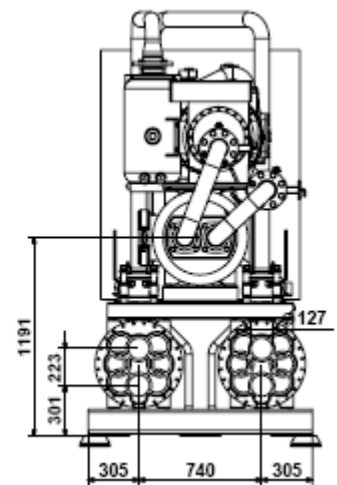
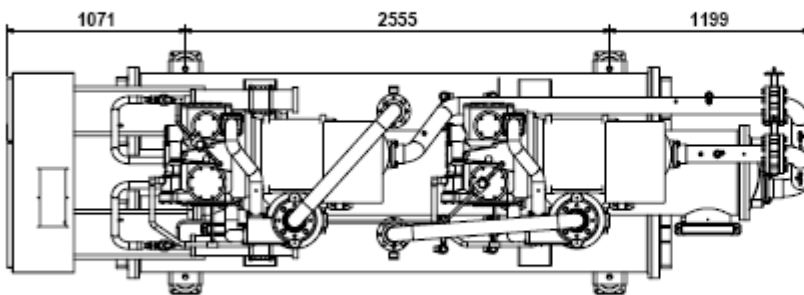
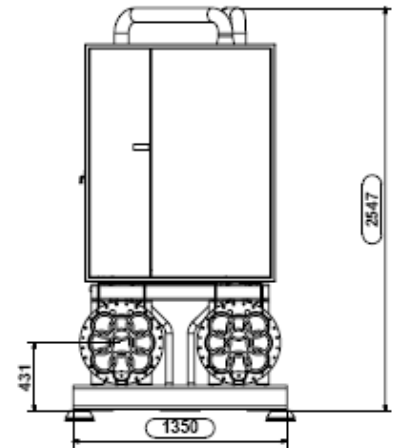
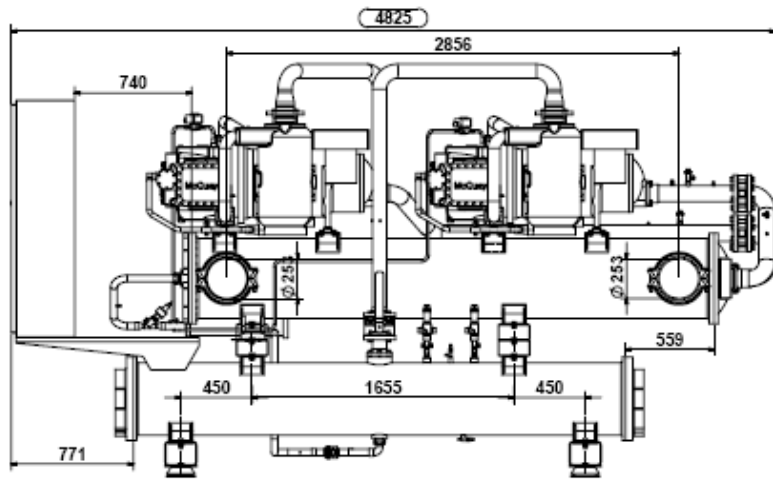

Proximus "Evolution" 508.2 ÷ 596.2 XE ST

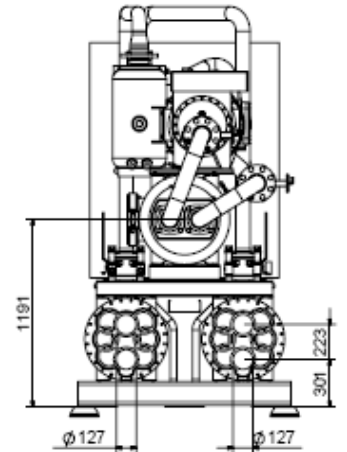
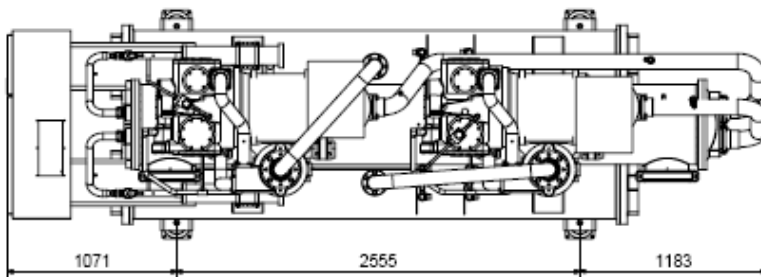
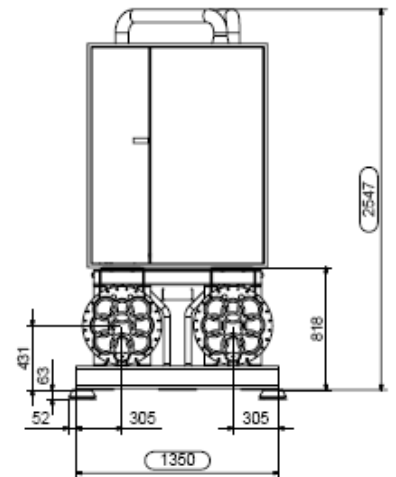
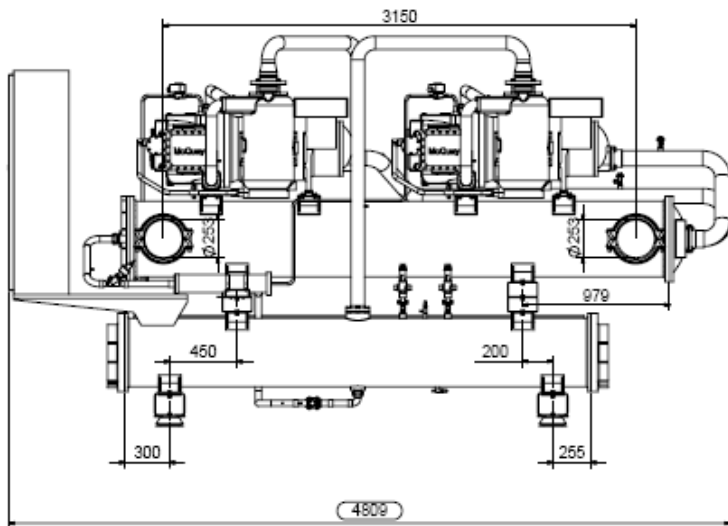

INSTALLATION NOTES

Warning

Installation and maintenance are to be performed only by qualified personnel who are familiar with local codes and regulations, and who are experienced with this type of equipment. Must be avoided the unit installation in places that could be considered dangerous for all the maintenance operations.

Handling

The chiller is mounted on heavy wooden skids to protect the unit from accidental damage and to permit easy handling and moving. It is recommended that all moving and handling be performed with the skids under the unit when possible and that the skids not be removed until the unit is in the final location.

Spreader bars must be used to protect the control cabinet and the other areas of the chiller.

Location

A levelled and sufficiently strong floor is required. If necessary, additional structural members should be provided to transfer the weight of the unit to the nearest beams.

Rubber-in-shear isolators can be furnished and field placed under each corner of the package. A rubber anti-skid pad should be used under isolators if hold-down bolts are not used. Vibration isolator in all water piping connected to the chiller are recommended to avoid straining the piping and transmitting vibration and noise.

Minimum space requirements

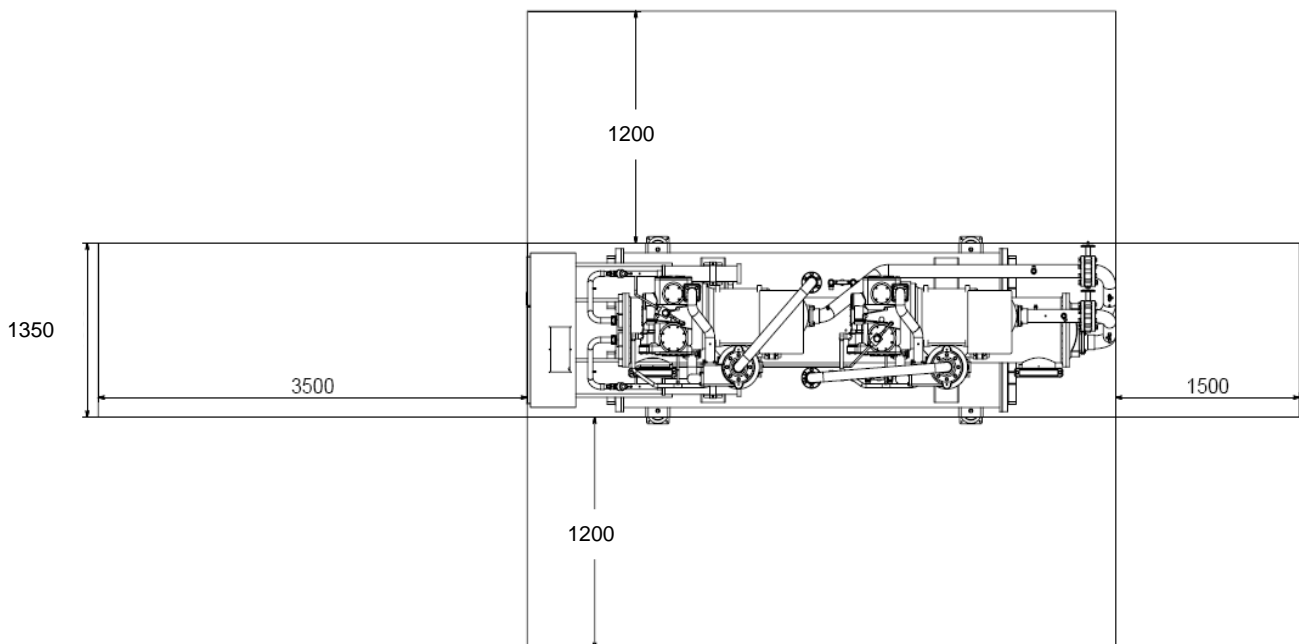

SPECIFICATIONS – PROXIMUS “EVOLUTION”

To supply and install, where specified in the project n° unit(s) water cooled chiller with cooling capacity of kW, to cool l/sec. of water from °C to °C, condenser entering water temperature°C, condenser leaving water temperature°C.

The unit should work with electricity at V, 3ph, 50Hz. The electrical power absorbed should not exceed kW. The units EER will be at least at the working conditions of the project. Part load EER will be at least at the working conditions of the project.

The units will have 1 or 2 independent refrigerant circuits, and the respective electronic microprocessor will allow the starting of the compressors. Each chiller will be factory assembled and protected by an epoxy paint.

The unit will be tested at full load in the factory at the nominal working conditions and water temperatures. Before shipment a full test will be held to avoid any losses. Chiller will be delivered to the job site completely assembled and charged with refrigerant and oil.

Comply with the manufacturer instructions for rigging and handling equipment.

GENERAL

All units should be designed and manufactured in accordance with applicable selections of the following which are equivalent to American Air-conditioning industry applicable codes:

Rating of chillers	EN 12055
Construction of pressure vessel	Pressure Equipment 97/23/EC (PED)
Machinery Directive	98/37/EC
Low Voltage Directive	2006/95/EC
Electromagnetic Compatibility Directive	2004/108/EC
Electrical & Safety Codes	IEC 60204-1
Manufacturing Quality Stds	ISO 9001:2000

REFRIGERANT

Will be accepted only R-410A.

UNIT DESCRIPTION

Each chiller consist of single or multiple semi-hermetic rotary screw compressor, direct expansion evaporator, water-cooled condenser section, control system and all components necessary for safe and controlled unit operation.

NOISE LEVEL AND VIBRATIONS

Sound pressure level at 1 meter distance in free field, semispheric conditions, shall not exceeddBA. The sound pressure levels must be rated in accordance to ISO 9614-2. Other types of rating unacceptable. Vibration level should not exceed 2 mm/s.

DIMENSIONS

Unit length shall not exceed mm, unit width shall not exceed mm, unit height shall not exceed mm.

CHILLER COMPONENTS

Compressors

- ✓ The compressors shall be field serviceable, semi-hermetic, single-screw type with one main helical rotor meshing with two opposed gaterotor. Twin-screw compressor will no be accepted because of the large bearing loads inherent with this design. For a Single-screw compressor the two exactly opposed gaterotors create two exactly opposed compression cycles which results in balanced forces acting on the rotor compressor. The gaterotors will be constructed of a carbon impregnated engineered composite material. The gaterotor supports will be constructed of cast iron.
- ✓ The oil injection shall be used for these compressors in order to get high EER also at high condensing pressure and low sound pressure levels in each load condition.

- ✓ Refrigerant system differential pressure shall provide oil flow through service replaceable, 0.5 micron, full flow, cartridge type oil filter internal to compressor. Filter bypass or oil pump not acceptable.
- ✓ The compressor's oil cooling must be realized by liquid injection. External dedicated heat exchanger and additional piping to carry the oil from the compressor to heat exchanger and viceversa will be not accepted.
- ✓ The compressor shall be direct electrical drive, without gear transmission between the screw and the electrical motor. The motor's compressor shall be designed for star/delta. Soft start should be available as option.
- ✓ Shall be present two thermal protection realized by a thermistor for high temperature protection to motor and a thermistor for discharge gas high temperature protection.
- ✓ The compressor shall be provided with an automatic spring return of capacity control valve to the minimum load position to ensure compressor starting always at minimum motor load so with the minimum mechanical stress.
- ✓ The compressor discharge connection shall be fitted with a check valve and with a stop valve.
- ✓ The compressor discharge shall be fitted with a head pressure control valve.

Evaporator

- ✓ The units shall be supplied with shell and tubes counter-flow evaporator single refrigerant pass. It will be direct expansion with refrigerant inside the tubes and water outside (shell side) with carbon steel tube sheets, with straight copper tubes that are spirally wound internally for higher efficiencies, expanded on the tube plates.
- ✓ The external shell, shall be linked with an electrical heater (option on request) to prevent freezing up to -28 C ambient temperature, commanded by a thermostat and shall be insulated with flexible, closed cell polyurethane insulation material.
- ✓ The evaporator will have 1 or 2 circuits, one for each compressor and shall be single refrigerant pass to ensure a simpler oil circulation so to ensure always a perfect oil return to the compressor.
- ✓ Evaporator is manufactured in accordance to PED approval.

Condensers

- ✓ Condensers will be shell and cleanable, through-tube type.
- ✓ The unit will have one condensers per circuit.
- ✓ Each condenser shall have a carbon steel and seamless, integrally finned high efficiency copper tubes, roll expanded into heavy carbon steel tube sheets.
- ✓ Water heads shall be removable and include vent and drain plugs.
- ✓ Condensers will come complete with liquid shut-off valve, spring loaded relief valve.

Refrigerant circuit

- ✓ The unit must have refrigerant circuits completely independent of each other with one compressor per circuit.
- ✓ Each circuit shall include an: electronic expansion valve, external high efficiency oil separator, a liquid line shut-off valve with charging connection, replaceable core filter-drier, sight glass with moisture indicator and insulated suction line. Suction line and discharge line shut-off valves are available as option.

Regulation of cooling capacity

- ✓ Each unit will have a microprocessor for the control of compressor slide valve's position (2 slide valves, one for each compressor's cycles).
- ✓ The slides shall have a stepless motion that allows a unit's operation with infinitely variable capacity control down to 25% (1 compressor) or down to 12,5% (2 compressors) of the cooling capacity. The chiller shall be capable of stable operation to a minimum of 25% (1 compressor) or to a minimum of 12,5% (2 compressors) of full load without hot gas bypass.
- ✓ Step unloading unacceptable because of evaporator leaving water temperature fluctuation and low compressor's efficiency at partial load.
- ✓ The system shall stage the unit based on the leaving water temperature.

Electronic expansion valve

- ✓ Electronic expansion valve allows a simple and perfect control system that quickly interacts at load variations. This valve combines two functions: liquid solenoid and electronic expansion valve.
- ✓ It is managed directly by a microprocessor to match exactly the plant thermal load.
- ✓ Thermostatic valve unacceptable because of:
 - its limited load range;
 - higher refrigerant pressure drop;
 - because of leaving evaporator water temperature control less good than an electronic device;
 - thermal expansion device needs a higher differential pressure between high pressure side and low pressure side to work correctly. This doesn't allow to work with low condensing pressure and therefore doesn't allow to reach the money saving that is possible to have with these chiller working conditions.

Control panel

- ✓ Field power connections, control interlock terminals, and unit control system should be centrally located in an electric panel (IP 54).
- ✓ The Power components and control equipment shall be separately mounted in different compartments of the control panel.
- ✓ The Compressor starting method will be star/delta, with an option for Softstart.
- ✓ Power and starting controls should include fuses and contactors for the compressor.
- ✓ Operating and safety controls should include energy saving; emergency stop switch; thermal overload protection for each compressor motor; high and low pressure cut-out switch (for each refrigerant circuit); anti-freeze thermostat; cut-out switch for each compressor.
- ✓ All of the information regarding the unit shall be shown on a display with a built-in calendar and clock that will provide unit scheduling throughout the year.
- ✓ The following features and functions shall be included:
 - resetting chilled water temperature by controlling the return water temperature or by a remote 4-20 mA DC signal;
 - soft load function to prevent the system from operating at full load during the chilled fluid pulldown period;
 - password protection of critical parameters of control;
 - start-to-start and stop-to-start timers to provide minimum compressor off-time with maximum motor protection;
 - communication capability with a PC or remote monitoring;
 - lead-lag selection by manual or automatically by circuit run hours;
 - double set point for brine unit version;
 - scheduling via internal time clock to allow programming of a yearly start-stop schedule accommodating weekends and holidays.

Display Capabilities

The controller as a minimum shall be capable of monitoring and displaying the following data: -

Operating Conditions

Ent./ Lvg. Evaporator fluid Temp.
Entering Condenser fluid Temp.
Operating Chilled Fluid Setpoint
Oil / Discharge gas Press. (per comp.)
Condensing Press. (per comp.)
Evaporator Press. (per comp.)

Alarms

Phase Monitor
Freeze Protection
Evaporator Flow
Low Gas Pressure (per comp.)
Transition Fault, (per comp.)
Oil Diff. press. (per comp.)

Unit Enabled
Compressor Enabled
Water Setpoint Reset
Demand Limit or Current Limit
(Site Selectable)

Low Oil Pressure (per comp.)
High Gas Pressure Trip (per comp.)
Motor Overload, (per comp.)
Transducer faults
Units Off-Line
External fault
Processor Faults
Maintenance requirements

Standard Customer Interfaces

The controller as a minimum shall be capable of providing the following interlocks: -

Chiller Enable Signal: Digital Input,
customer contact must be capable of handling 24Volts, 50HZ, 1 Amp.

Chiller Common Fault: Volt free, normally open, digital contact,
Must be capable of switching 250 V, 50 HZ, 10 Amp.

Pump Enable Signal:: Volt free, normally open, digital contact,
Must be capable of switching 250 V, 50 HZ, 10 Amp.

Setpoint Override:: 4 – 20 mA DC analogue input signal.

Demand Limit:: 4 – 20 mA DC analogue input signal.

Or

Current Limit:: 4 – 20 mA DC analogue input signal.

Optional Customer Interfaces

Compressor Running Signals: Volt free, normally open, digital contact,
Capable of switching 250 V, 50 HZ, 10 Amp.

Optional High Level Communications Interface

Using ModBus, Lonworks or Bacnet protocols

We reserve the right to make changes in design and construction at any time without notice, thus the cover picture is not binding.



McQuay is participating in the Eurovent
Certification Programme
Product are as listed in the Eurovent
Directory of Certified Products

McQuay[®]
International

McQuay Italia S.P.A.

S.S. Nettunense, km 12+300 – 00040 Cecchina (Roma) Italia – Tel. (06) 937311 – Fax (06) 9374014 – E-mail: info@mcquayeuropa.com

Web site: www.mcquayeuropa.com