

# FlowCon SM



*The World's most Advanced Control Valves  
Now with New State-of-the-Art User Friendly Actuator*

# FLOW

# FlowCon SM

## *Dynamic Temperature Control Valve*



A common problem in hydronic systems is choosing the proper control valve while considering the requirements of acceptable authority. Along with this are the problems of determining the characteristics of the circuit necessary to assess the authority of the control valve.

Unstable and inaccurate regulation is often the consequence of over/under sizing a control valve. This is due to the fact that it is impossible to select a traditional control valve with a coefficient which optimally fits the given design parameters. Often the problem is exaggerated by pressure drop fluctuations across the control valve, which occur at varying loads in the system.

The FlowCon SM valve is a dynamic control valve which means the valve automatically keeps a constant differential pressure across the internal controlling orifice of the valve. Consequently, pressure drop fluctuations across the FlowCon SM will not affect the set flow through the valve. FlowCon SM can be set to limit the maximum design flow, which makes over-sizing control valves obsolete. Extensive calculations and assessments of the authority of the selected valve are eliminated. The dynamic flow characteristics keep the FlowCon SM in constant authority and automatically balanced, eliminating the requirement for a separate balancing valve in the circuit.

FlowCon SM dynamic temperature control valves are designed as an automatic temperature control for coils and AHUs; as a two-way regulation valve in HVAC installation such as radiator heating circuit or inventing heat systems; as a control valve for heat exchangers in heating systems to control floor heating circuits or other secondary heating circuits and as a control valve in hot water tank systems.

It is designed to control the rate of fluid flow to a specific terminal unit or coil. The FlowCon SM includes an innovative self adjustment feature which enables each valve continuously to self balance. This ensures delivery of precisely the flow rate required by each terminal unit, independent of pressure fluctuations in the hydronic system. Each FlowCon SM can also be adjusted to set an accurate maximum flow rate limit to each circuit.

### Features and Benefits

- **Pressure independent flow control.**
- **Total valve authority.**
- **User friendly** touch panel on actuator for selection of flow, control input etc. (optional on SM 1/2"-1 1/2").
- **Save time and labor;** installation and adjustment of balancing valves are eliminated.
- **Cv sizing calculations and problems are eliminated;** each valve is adjustable to 51 different maximum flow rate settings.
- **Feedback signal** provides information of current valve position, which can be converted into flow rate.



- **Optional failsafe power storage feature** which opens or closes the valve in case external power supply fails.
- **Continuously displaying** flow rate - and scrolling other actuator information (optional on SM 1/2"-1 1/2").
- **Actuator** is suitable for electrical modulating, 3-point-floating or 2 position signals.
- **Pressure/temperature measurement plugs** for verifying operating pressure differential range or checking  $\Delta T$  across the coil.
- **Double union end or flange connection** for ease of installation.

#### Principle of Operation

On closer examination of the inner workings of the FlowCon SM, the function is best described as 2 valves in 1. The first valve (V1) regulates the pressure differential across the second valve (V2) by means of a rolling diaphragm counteracted by a spring. The second valve is a calibrated variable orifice device adjusted by the actuator (similar to a standard modulating control valve). The diaphragm reacts to the system and regulates the pressure differential across the actuated control valve orifice to maintain its flow rate.

#### System Layout Comparison and Valve Authority

The FlowCon SM is a 100% authority pressure independent flow control valve which instantaneously self-balance at all points of operation, even when

there is variance in pressure differential. As long as the pressure differential across the valve is within the operating range, the Cv of the valve is variable, being continuously regulated to keep the control valve in constant authority.

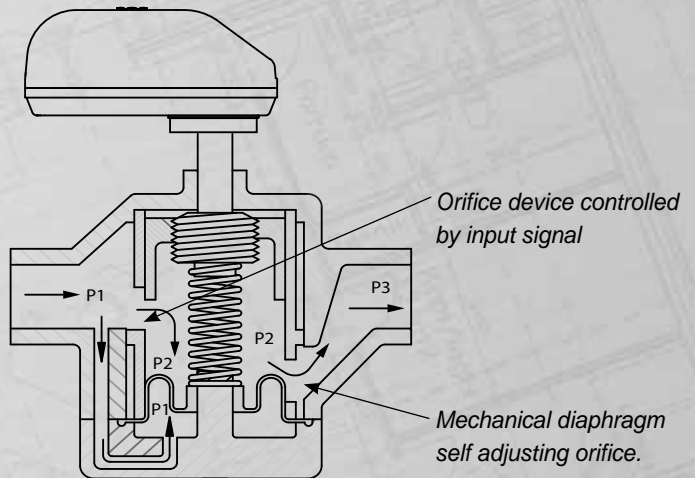
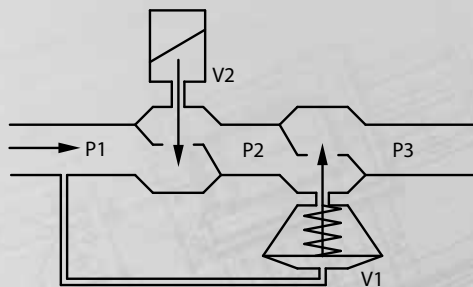

## Hydronic Balance

The actuator can be pre-set to limit the working range of the valve which limits the maximum flow rate through the valve. Consequently, hydronic balance is achieved automatically without the use of additional balancing valves.

## User friendly programmable actuator

All SM-valves can be fitted with the new state-of-the-art actuators which both in design and user-friendliness are unique. On the touch panel on the actuator all features are selected. It is possible to select 51 different flow rate maximums per valve. Both control input signal and feedback signal are also selected on the touch panel. Input signal can be modulating, 3-point-floating or 2 position and feedback signal can be "automatic", 0(2)-10V or 4-20mA.

The control signals i.e. input signals and feedback automatically adapt to the pre-set working range of the valve. This means that maximum signal is equal to the maximum pre-set design flow limit. The digital control system is allowed to work throughout the full range of the signal independent of the working range. Further, the valve can be selected to operate either in NC-mode (normally closed) so that the valve opens with an increasing signal or in NO-mode (normally open) so that it closes with an increasing signal.

## Failsafe

The failsafe option will move the valve to safety position (standard is failsafe closed) during power failure utilized by a rechargeable battery.

## Technical Data

For further information and part number selection please see FlowCon tech note.

For latest updates please see [www.flowcon.com](http://www.flowcon.com).

		SM1 1/2"-1"	SM2 1"-1 1/2"	SM3 2"-3"			SM4 3"-4"			SM5 5"-6"	
Pressure Differential	(kPaD)	33-320	40-320	35-400	35-400	80-400	35-400	60-400	60-400	35-400	60-400
	(psid)	4.6-46	5.8-46	5.1-58	5.1-58	11.6-58	5.1-58	8.7-58	8.7-58	5.1-58	8.7-58
Flow Rate	(l/sec)	0.176-0.685	0.513-2.34	1.48-4.16	2.57-7.15	3.55-9.88	3.49-9.38	4.73-14.2	3.68-20.2	6.48-23.3	7.10-29.5
	(GPM)	2.79-10.9	8.14-37.1	23.4-66.0	40.7-113	56.3-157	55.4-149	75.0-225	58.3-320	103-369	113-468
Static Pressure	(kPa)	2500			4000						
	(psi)	360			580						
Temperature Rating (media / ambient)	(°C)	-20 to +120 / -10 to +50									
	(°F)	-4 to +248 / +14 to +122									
Pressure Drop Data	NOTE: For pump head calculations, add the minimum pressure differential for the index circuit to the other components pressure losses (i.e. valves, coil, etc.)										
Valve	(Kv-value) (m³/hr)	4.1	12.6	24.0	39.5	39.5	58.3	58.3	89.0	132.3	132.3
	(Cv-value) (GPM)	4.8	14.6	27.8	45.8	45.8	67.6	67.6	103.2	153.5	153.5



[www.flowcon.com](http://www.flowcon.com)

**DENMARK**  
FlowCon International A/S  
flowom

**DUBAI**  
FlowCon Int. ME LLC  
mem

**USA**  
FlowCon Americas LLC  
usm

**BRASIL**  
FlowCon Latin America Ltda  
lam

**SINGAPORE**  
FlowCon Int. Asia office  
asm